

EXPANSION JOINT REHABILITATION DETAIL

GENERAL NOTES:

1. THE NEW HMA OVERLAY SHALL BE SAWED, REMOVED AND THE JOINT AREA CLEANED. PRIOR TO PLACING THE HOT-POURED JOINT SEALER, THE JOINT SHALL BE BLOWN OUT WITH COMPRESSED AIR.
2. THIS WORK WILL BE PAID FOR AT THE CONTRACT UNIT PRICE PER FOOT FOR EXPANSION JOINT REHABILITATION.

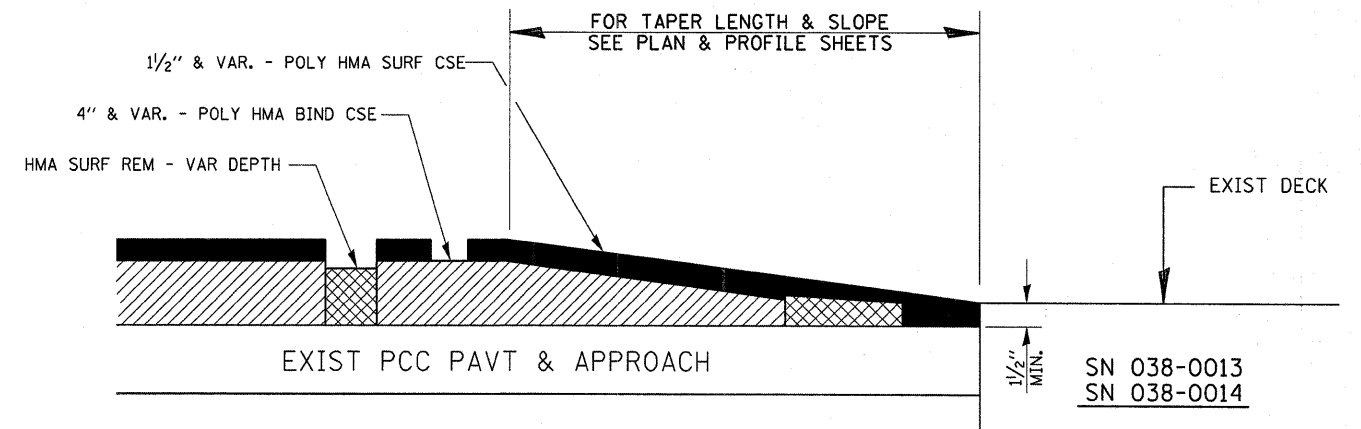

TAPERS @ SN 038-0013/0014

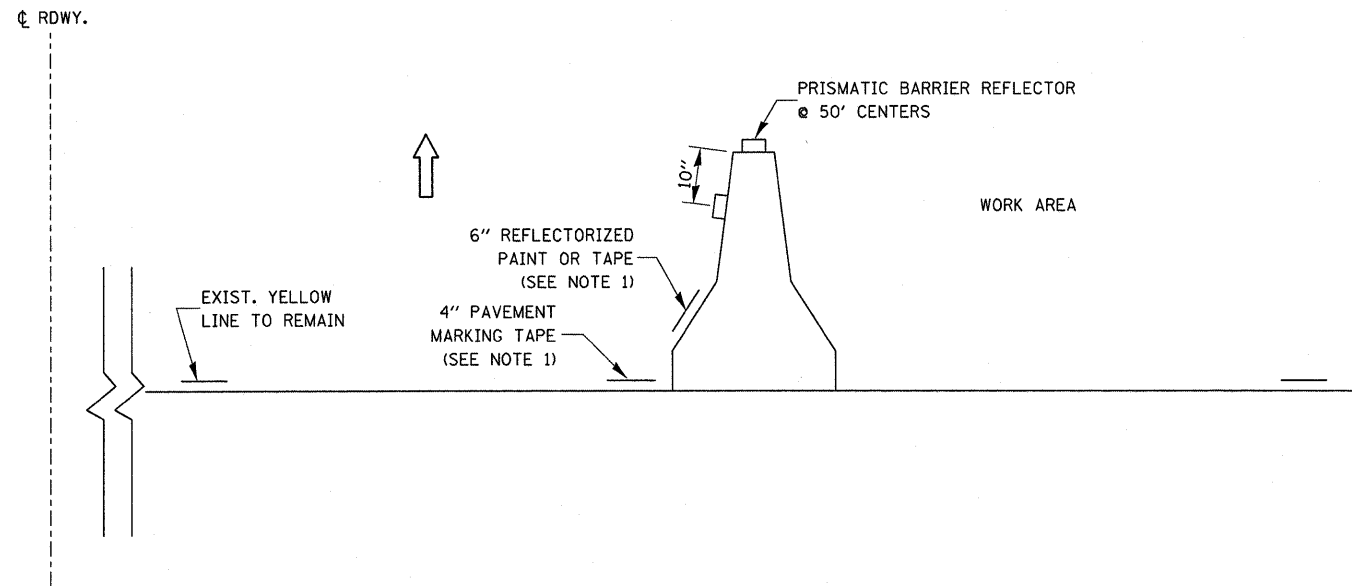

NOTES:

1. THE CONTRACTOR HAS THE OPTION OF USING EITHER THE LINE ON THE TEMPORARY CONCRETE BARRIER OR ON THE PAVEMENT.
2. THE COLOR OF THE REFLECTORS AND PAVEMENT/BARRIER MARKING LINE WILL VARY WITH STAGING AND SHALL MATCH THE EXISTING LINE IN THE WORK AREA.
3. THE COST OF THE REFLECTORS AND THE PAVEMENT/BARRIER MARKING LINE IS INCLUDED IN THE COST OF THE TEMPORARY CONCRETE BARRIER.

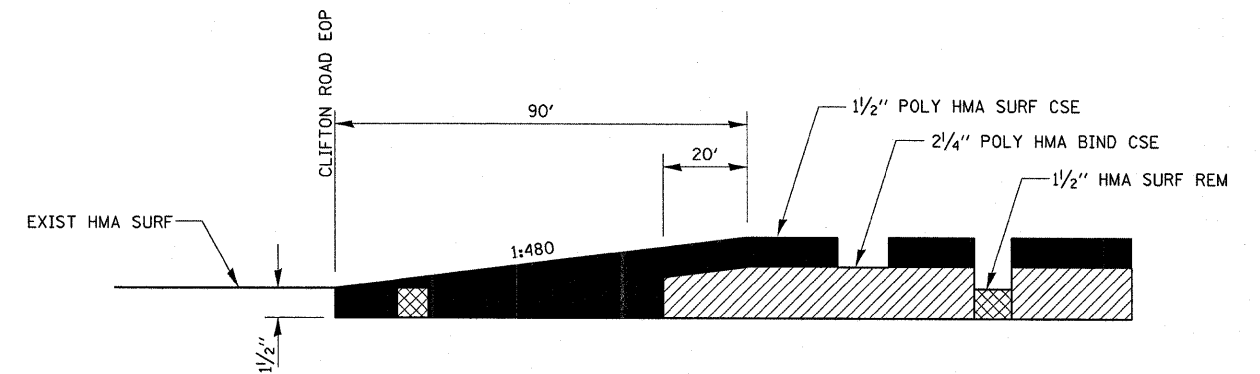

TAPER AT RAMPS

FILE NAME =	USER NAME = duncanbd	DESIGNED -	REVISED -
ct:\pw\work\PIWIDOT\DUNCANBD\dms38392\ep05105-ahd-details.DGN		DRAWN -	REVISED -
		CHECKED -	REVISED -
		DATE -	REVISED -

**STATE OF ILLINOIS
DEPARTMENT OF TRANSPORTATION**

DETAILS			
SCALE:	SHEET NO.	OF SHEETS	STA. TO STA.

F.A.I. RTE.	SECTION	COUNTY	TOTAL SHEETS	SHEET NO.
57	(38-1,2)RS-2 & I	IROQUOIS	263	61
CONTRACT NO. 66981				
ILLINOIS FED. AID PROJECT				