

TRANSVERSE JOINTS

HEADERS

LONGITUDINAL JOINTS

CONTRACTION JOINT
(TYPE C & TYPE S)

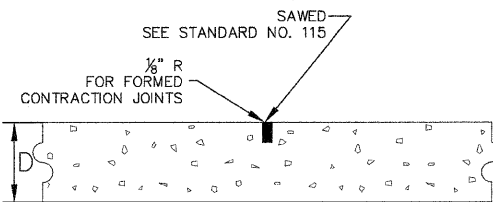

NOTE:
FORMED JOINTS LESS THAN D/3 MUST BE
SAWED TO REQUIRED DEPTH

DOWELED EXPANSION JOINT
(TYPE ED)

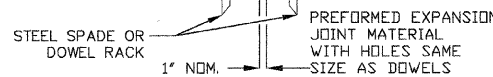
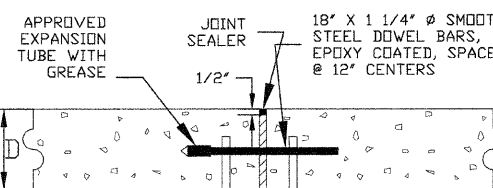

LONGITUDINAL JOINT ABUTTING
EXISTING PAVEMENT

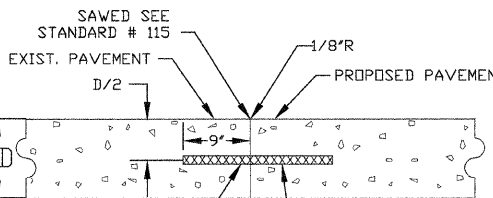

BARS TO BE DRILLED AND GROUTED INTO EXISTING PAVEMENT

REVISED	MDW	03/31/05
REVISED	MDW	07/16/04
REVISED	MDW	04/08/00
METRIC	BJT	12/19/96
REVISED	CWE	06/27/91
STAND102.DWG	MDW	03/91

NOT TO SCALE

CONSTRUCTION JOINT OR
EMERGENCY HEADER
(TYPE D)

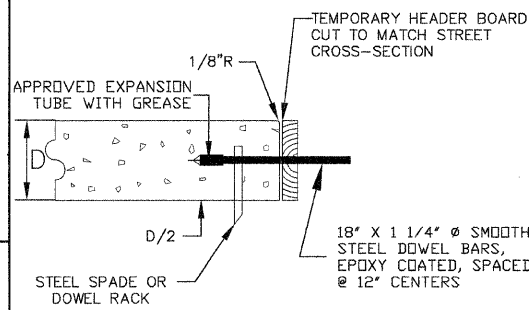

NOTE:
TO BE CONSTRUCTED AS A
CONTRACTION JOINT WHEN
CONSTRUCTION IS RESUMED

PERMANENT HEADER

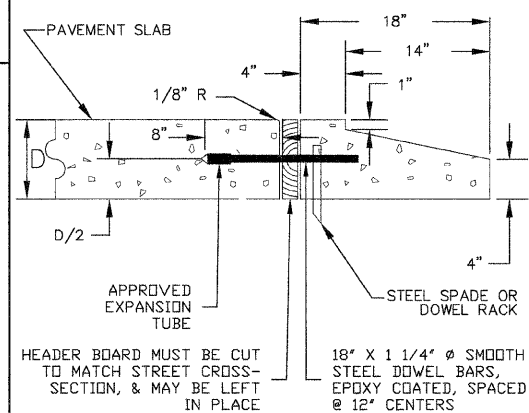

S:\... \MISC\STANDARD\CRI_STD\102.DWG

LONGITUDINAL CONTRACTION JOINT
WITH DEFORMED BARS
(TYPE L)

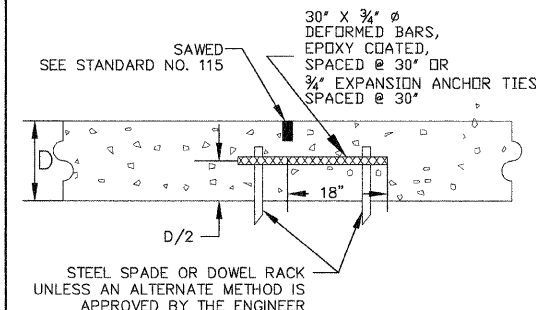

STEEL SPADE OR DOWEL RACK
UNLESS AN ALTERNATE METHOD IS
APPROVED BY THE ENGINEER

KEYED CONSTRUCTION JOINT
(TYPE K)
(FOR PAVEMENT >9')

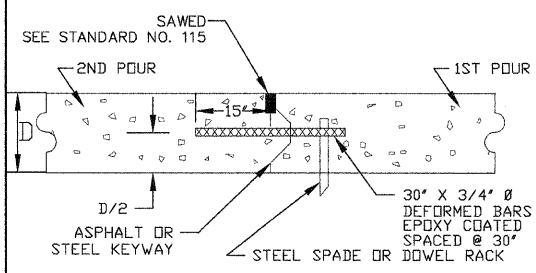

TRANSVERSE JOINTS, HEADERS,
AND LONGITUDINAL JOINTS

CITY OF ROCK ISLAND
ENGINEERING DIVISION
STANDARD NO. 102

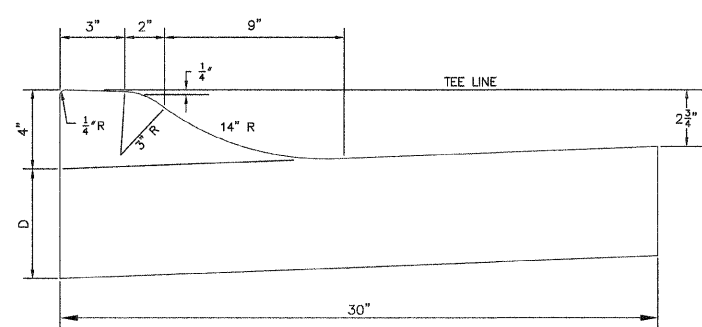

ROLL-OVER CURB

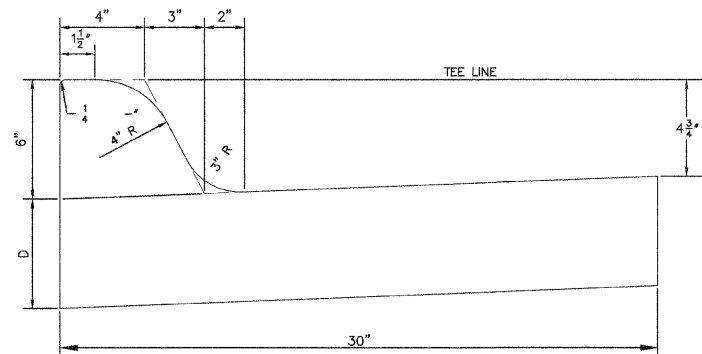

STANDARD CURB SECTION

NOT TO SCALE

METRIC	PMGJ	01/27/97
STAND103.DWG	CWE	08/03/92
REVISION	BY	DATE

S:\... \MISC\STANDARD\CRI_STD\103.DWG

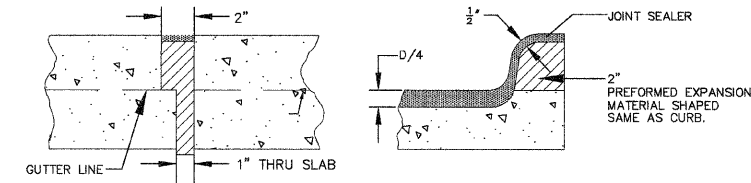

WITH EXPANSION JOINT

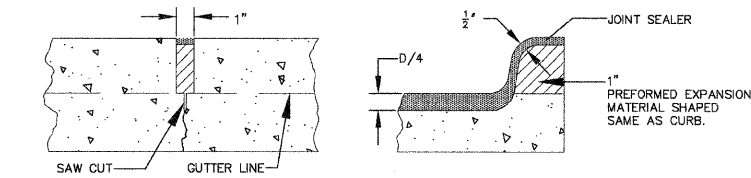

WITH TRANSVERSE CONTRACTION JOINT

CURB JOINT - AT INTERSECTION RETURN

CURB SECTION &
CURB JOINT DETAILS

CITY OF ROCK ISLAND
ENGINEERING DIVISION
STANDARD NO. 103

85497
09-00186-00-RS
C.R.I. STANDARD DETAILS
CITY OF ROCK ISLAND
ENGINEERING DIVISION

30th Street Resurfacing
31st Avenue to Blackhawk Road

Job Number	2592	Date	2-24-09
Computer Drawing Name	2592 Standard Details	By	mdw
Sheet	32	Of	32

