

SECTION B-B

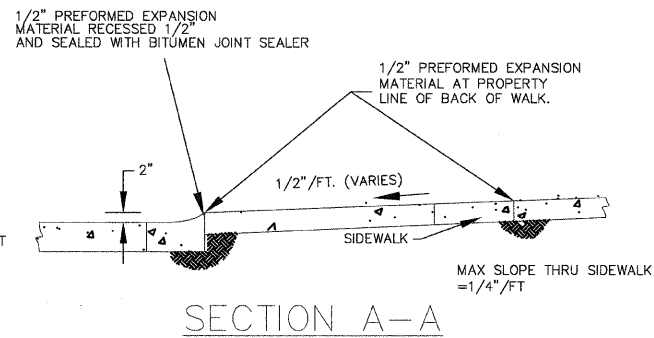

SECTION A-A

- NOTES:
1. DRIVEWAY AND SIDEWALK THICKNESS:  
RESIDENTIAL - 6" (5" IF 42# MESH IS USED)  
COMMERCIAL - 7" (6" IF 42# MESH IS USED)
  2. DRIVEWAY AND CURB CUT PERMITS MUST BE OBTAINED FROM CITY ENGINEER PRIOR TO CONSTRUCTION.
  3. IF AN EXISTING JOINT IS WITHIN 2' OF THE PROPOSED SAW CUT IN THE STREET, THEN ALL OF THE GUTTER SECTION SHOULD BE REMOVED & REPLACED WITH NEW PAVEMENT.
  4. ALL CONSTRUCTION SHALL BE IN ACCORDANCE WITH THE ROCK ISLAND STANDARD SPECIFICATIONS, THE MUNICIPAL CODE AND THE IDOT STANDARD SPECIFICATIONS FOR ROAD AND BRIDGE CONSTRUCTION.
  5. EXPANSION TO BE FLUSH WITH FACE OF BACK OF CURB SO A TIGHT, STRAIGHT JOINT IS ATTAINED, AND FULL DEPTH OF DRIVE.
  6. IF THE DISTANCE FROM THE BACK OF CURB TO THE SIDEWALK IS LESS THAN 3', DELETE SIDEWALK THRU DRIVEWAY. (SEE CRI STANDARD NO. 107)
  7. NO MASONITE TO BE USED AS FORMS
  8. EXPANSION MATERIAL SHALL NOT BE USED AS FORMS

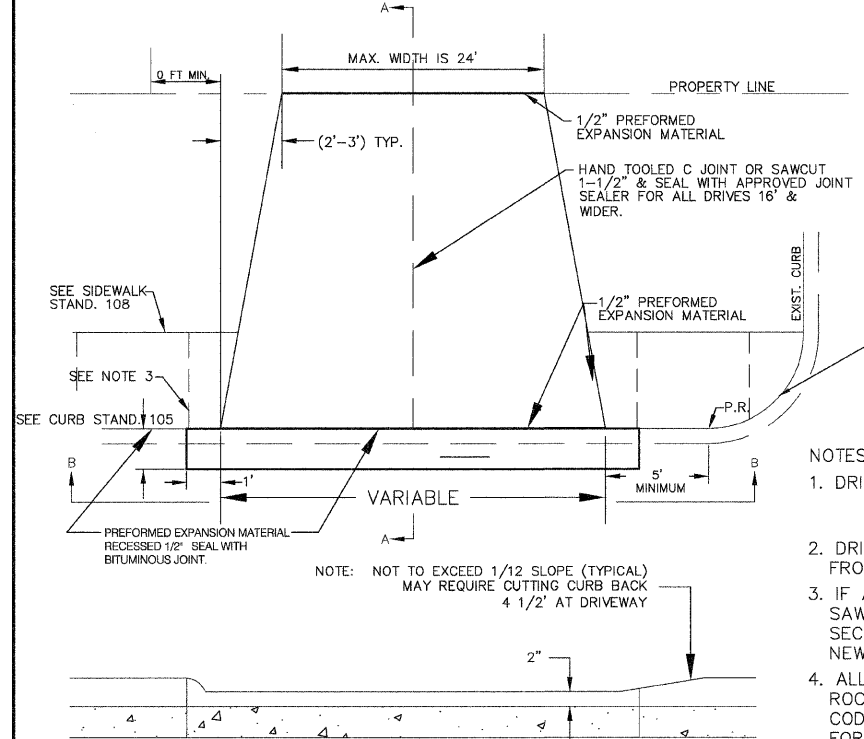

SECTION B-B

- NOTES:
1. DRIVEWAY AND SIDEWALK THICKNESS:  
RESIDENTIAL - 6" (5" IF 42# MESH IS USED)  
COMMERCIAL - 7" (6" IF 42# MESH IS USED)
  2. DRIVEWAY AND CURB CUT PERMITS MUST BE OBTAINED FROM CITY ENGINEER PRIOR TO CONSTRUCTION.
  3. IF AN EXISTING JOINT IS WITHIN 2' OF THE PROPOSED SAW CUT IN THE STREET, THEN ALL OF THE GUTTER SECTION SHOULD BE REMOVED & REPLACED WITH NEW PAVEMENT.
  4. ALL CONSTRUCTION SHALL BE IN ACCORDANCE WITH THE ROCK ISLAND STANDARD SPECIFICATIONS, THE MUNICIPAL CODE AND THE IDOT STANDARD SPECIFICATIONS FOR ROAD AND BRIDGE CONSTRUCTION.
  5. EXPANSION TO BE FLUSH WITH FACE OF BACK OF CURB SO A TIGHT, STRAIGHT JOINT IS ATTAINED.
  6. NO MASONITE TO BE USED FOR FORMS
  7. EXPANSION MATERIAL SHALL NOT BE USED AS FORMS

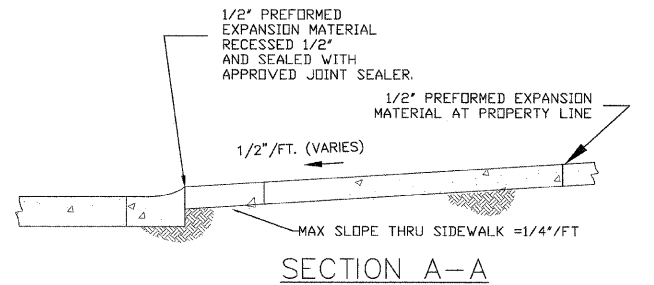

SECTION A-A

NOT TO SCALE

REVISED	MJH	05/07/01
REVISED	PJK	01/10/01
REVISED	TAB	01/27/01
REVISED	PMCJ	08/02/99
REVISED	CAM	05/14/99
METRIC	BJT	12/20/97
REVISED	RDJ	07/19/95
REVISED	CWE	06/27/91
REVISION	BY	DATE

S:\... \MISC\STANDARD\CRI\_STD\106.DWG

**DRIVEWAY STANDARD  
FOR DRIVES WITH SIDEWALKS 2'  
OR MORE FROM BACK OF CURBS**

CITY OF ROCK ISLAND  
ENGINEERING DIVISION  
STANDARD NO. 106

REVISED	MJH	05/03/01
REVISED	PJK	01/10/2001
REVISED	TAB	01/27/2000
REVISED	PMCJ	08/02/99
REVISED	CAM	05/14/99
METRIC	BJT	12/26/96
REVISED	RDJ	07/19/95
STANDARDIZED	CWE	06/28/91
REVISION	BY	DATE

S:\... \MISC\STANDARD\CRI\_STD\107.DWG

**DRIVEWAY STANDARD  
FOR DRIVES WITH SIDEWALK  
LOCATED AT BACK OF CURB**

CITY OF ROCK ISLAND  
ENGINEERING DIVISION  
STANDARD NO. 107

85497  
09-00186-00-RS  
C.R.I. STANDARD DETAILS  
**CITY OF ROCK ISLAND  
ENGINEERING DIVISION**

30th Street Resurfacing  
31st Avenue to Blackhawk Road

Job Number	2592	Date	2-24-09
Computer Drawing Name	2592 Standard Details	By	mdw
Sheet	33	Of	33



ROCK ISLAND  
ILLINOIS