

ROUTE NO.	SECTION	COUNTY	TOTAL SHEETS	SHEET NO.
ILL. 5489	*	LEE	35	17
FED. ROAD DIST. NO. 7		ILLINOIS	FED. AID PROJECT-	
* Section 03-00160-00-PV			Contract #85503	

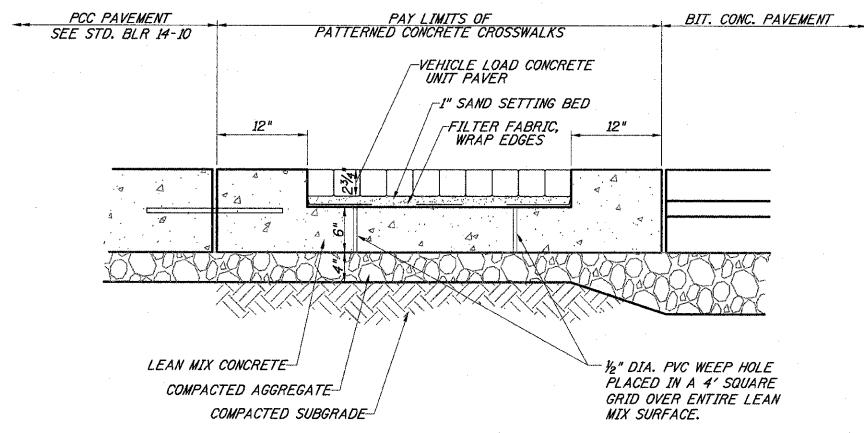

SECTION THRU PATTERNED CONCRETE CROSSWALKS

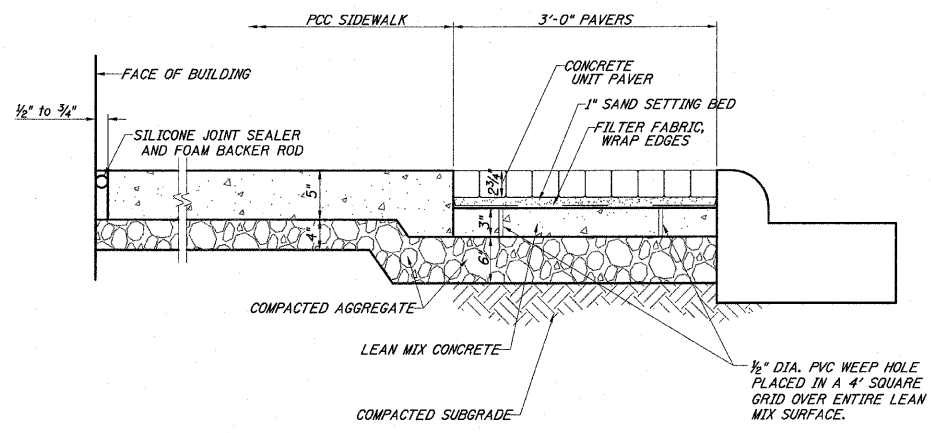

SECTION THRU PRECAST CONCRETE SIDEWALKS

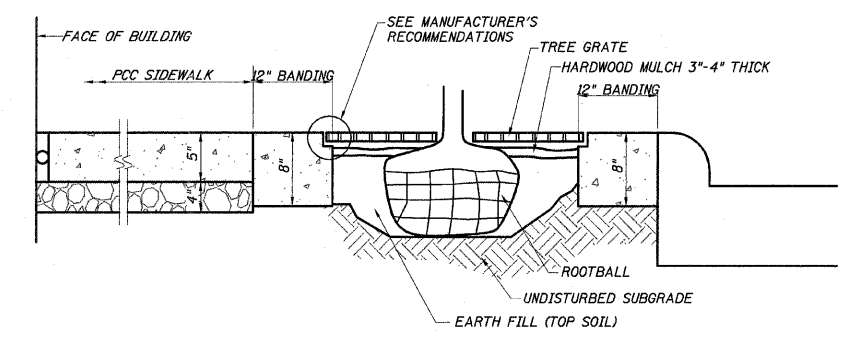

TREE PLANTING & GRATE DETAIL (SEE SPECIAL PROVISIONS)

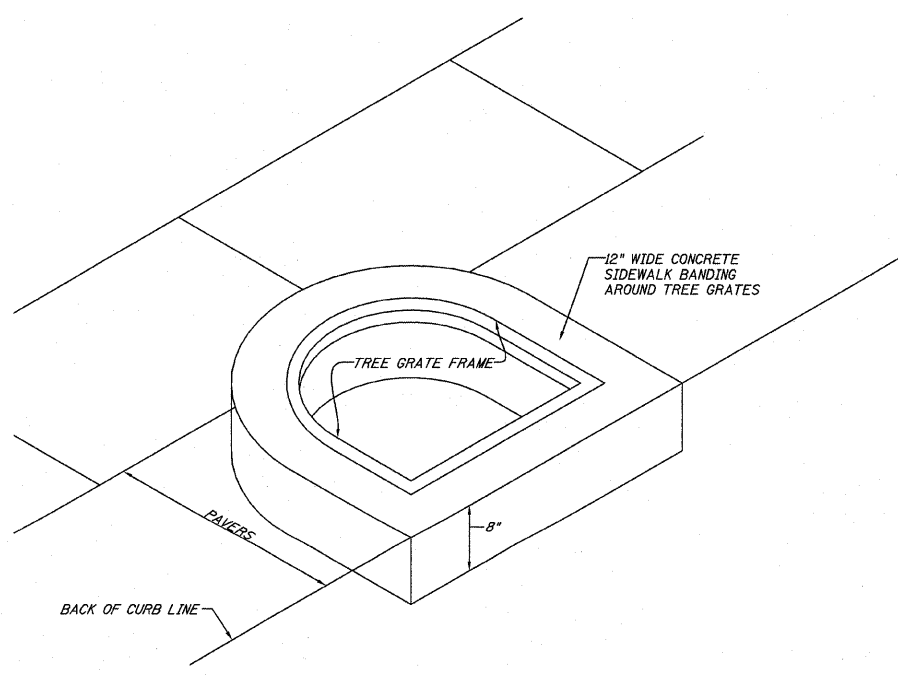

TYPICAL ROUNDED TREE FRAME GRATE SURROUND (SEE SPECIAL PROVISIONS)

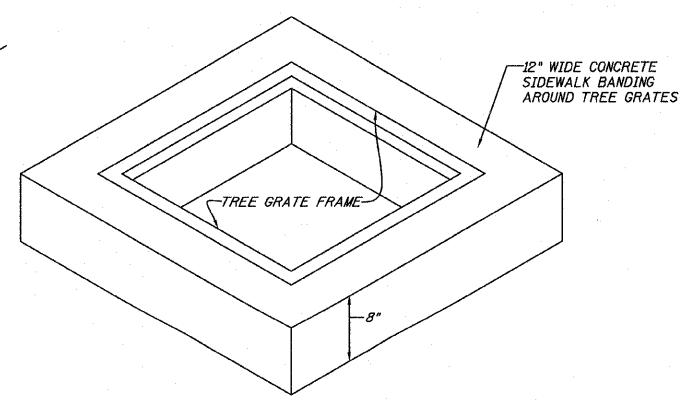

TYPICAL SQUARE TREE FRAME GRATE SURROUND (SEE SPECIAL PROVISIONS)

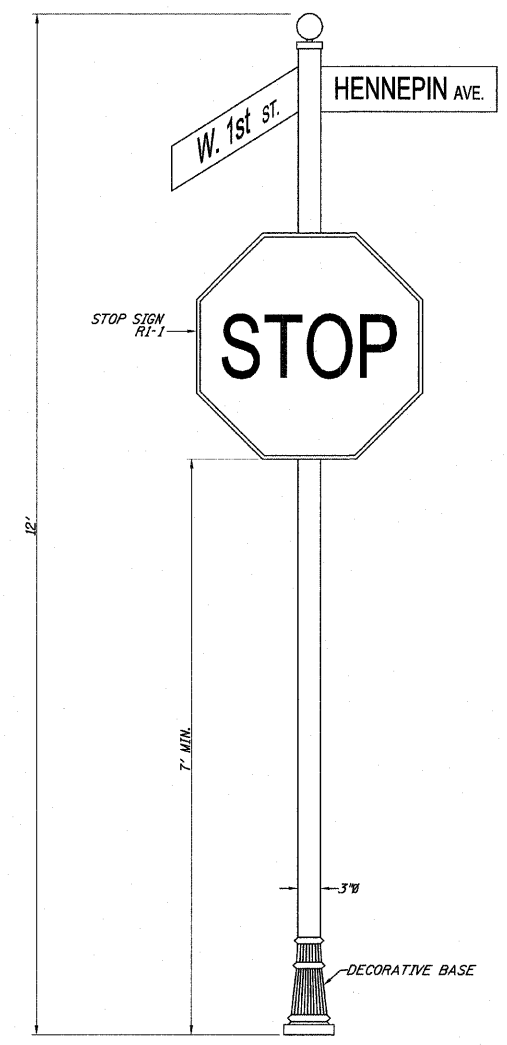

TYPICAL ORNAMENTAL SIGN POST DETAIL (SEE SPECIAL PROVISIONS)

SIDEWALK DETAILS	
HENNEPIN AVE. SECTION 03-00160-00-PV CITY OF DIXON	
wendler GROUND BREAKING SOLUTIONS engineers - surveyors - scientists	Date: 09/25/09 Job: 2090205
www.wendlers.com	ph: 815.288.2261