

|             |                |                    |
|-------------|----------------|--------------------|
| F.A.P. RTE. | SECTION        | COUNTY             |
| 525         | 01-00509-00-RP | WINNEBAGO          |
| ILLINOIS    |                | CONTRACT NO. 85612 |

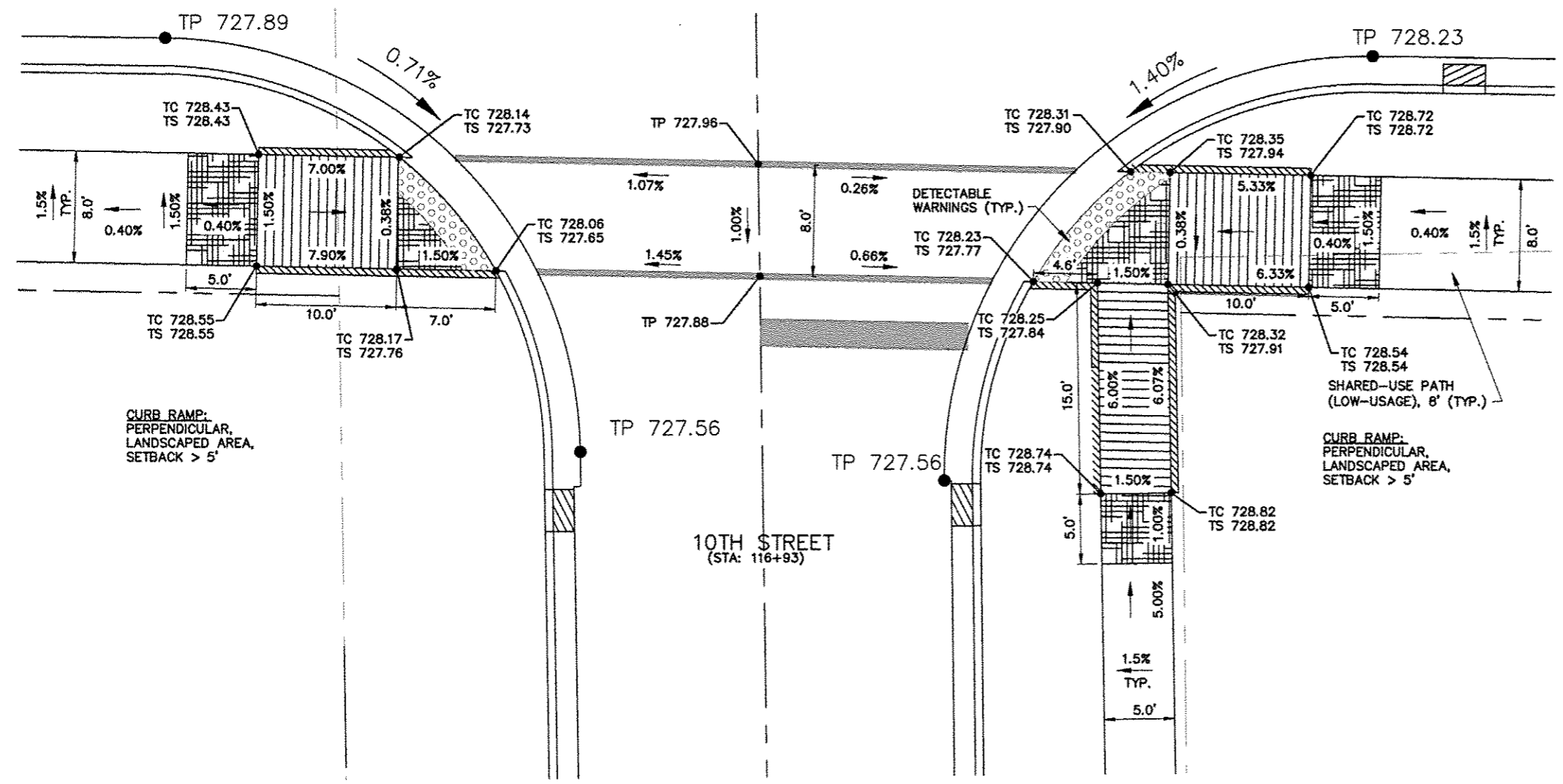

SCALE:  
PLAN: 1" = 5'  
0 5 10  
Scale In Feet



GENERAL NOTES:

- 1) ALL DETECTABLE WARNINGS ARE 24" WIDE.
- 2) ALL RAMP SLOPES GREATER THAN 1:20 REQUIRE AN UPPER LEVEL LANDING A MINIMUM OF 5' LONG. UPPER LEVEL LANDINGS ARE NOT REQUIRED FOR RAMP SLOPES FLATTER THAN 1:20.
- 3) MAXIMUM SLOPE OF SIDEWALK RAMP SHALL NOT EXCEED 12:1. SIDEWALK RAMP SHALL ALSO BE A MAXIMUM LENGTH OF 15 FEET.
- 4) 6" WIDE VARIABLE HEIGHT CURB ALONG SIDEWALK SHALL BE MEASURED AND PAID AS PORTLAND CEMENT CONCRETE SIDEWALK.
- 5) SPOT ELEVATIONS:  
TS = TOP OF SIDEWALK OR SLAB  
TC = TOP OF CURB  
TP = TOP OF PAVEMENT  
ME = MATCH EXISTING
- 6) PREFABRICATED DETECTABLE WARNINGS SHALL BE FIT TO THE BACK OF CURB WITH NO MORE THAN A 6" GAP BETWEEN THE PREFABRICATED TILE AND THE BACK OF CURB BY USING EITHER TAPERED OR RADIUS TILE.
- 7) CURB RAMPS SHALL COMPLY WITH "PROPOSED ACCESSIBILITY GUIDELINES FOR PEDESTRIAN FACILITIES IN THE PUBLIC RIGHT-OF-WAY", LATEST EDITION, PUBLISHED BY THE U.S. ACCESS BOARD AND THE FINAL REPORT OF THE US ACCESS BOARD PUBLISHED JANUARY 2011 ENTITLED, "INITIATIVE ON DIMENSIONAL TOLERANCES IN CONSTRUCTION, DIMENSIONAL TOLERANCES FOR SURFACE ACCESSIBILITY.
- 8) CURB RAMP STANDARDS INCLUDE:  
424001 PERPENDICULAR CURB RAMPS FOR SIDEWALKS  
424006 DIAGONAL CURB RAMPS FOR SIDEWALKS  
424011 CORNER PARALLEL CURB RAMPS FOR SIDEWALKS  
424021 DEPRESSED CORNER FOR SIDEWALKS  
424026 ENTRANCE/ALLEY PEDESTRIAN CROSSINGS  
424031 MEDIAN PEDESTRIAN CROSSINGS

LEGEND:

- DETECTABLE WARNINGS
- LEVEL LANDING (MAX. GRADE = 2.0%)
- RAMP RUNNING SLOPE (MAX. SLOPE = 1:12) (MAX LENGTH = 15')
- 6" WIDE CURB, VARIABLE HEIGHT (INCLUDED FOR PAYMENT WITH PCC SIDEWALK)
- RUNNING SLOPE (MAX. SLOPE = 1:20)
- 4' X 4' CLEAR MANEUVERING AREA
- EXISTING R.O.W.
- PROPOSED R.O.W.

| REVISIONS |             |      |
|-----------|-------------|------|
| REV. NO.  | DESCRIPTION | DATE |
|           |             |      |
|           |             |      |
|           |             |      |

|             |                |                    |
|-------------|----------------|--------------------|
| F.A.P. RTE. | SECTION        | COUNTY             |
| 525         | 01-00509-00-RP | WINNEBAGO          |
| ILLINOIS    |                | CONTRACT NO. 85612 |



SCALE:  
 PLAN: 1" = 5'  
 0 5 10  
 Scale In Feet

GENERAL NOTES:

- ALL DETECTABLE WARNINGS ARE 24" WIDE.
- ALL RAMP SLOPES GREATER THAN 1:20 REQUIRE AN UPPER LEVEL LANDING A MINIMUM OF 5' LONG. UPPER LEVEL LANDINGS ARE NOT REQUIRED FOR RAMP SLOPES FLATTER THAN 1:20.
- MAXIMUM SLOPE OF SIDEWALK RAMP SHALL NOT EXCEED 12:1. SIDEWALK RAMPS SHALL ALSO BE A MAXIMUM LENGTH OF 15 FEET.
- 6" WIDE VARIABLE HEIGHT CURB ALONG SIDEWALK SHALL BE MEASURED AND PAID AS PORTLAND CEMENT CONCRETE SIDEWALK.
- SPOT ELEVATIONS:  
 TS = TOP OF SIDEWALK OR SLAB  
 TC = TOP OF CURB  
 TP = TOP OF PAVEMENT  
 ME = MATCH EXISTING
- PREFABRICATED DETECTABLE WARNINGS SHALL BE FIT TO THE BACK OF CURB WITH NO MORE THAN A 6" GAP BETWEEN THE PREFABRICATED TILE AND THE BACK OF CURB BY USING EITHER TAPERED OR RADIUS TILE.
- CURB RAMPS SHALL COMPLY WITH "PROPOSED ACCESSIBILITY GUIDELINES FOR PEDESTRIAN FACILITIES IN THE PUBLIC RIGHT-OF-WAY", LATEST EDITION, PUBLISHED BY THE U.S. ACCESS BOARD AND THE FINAL REPORT OF THE U.S. ACCESS BOARD PUBLISHED JANUARY 2011 ENTITLED, "INITIATIVE ON DIMENSIONAL TOLERANCES IN CONSTRUCTION, DIMENSIONAL TOLERANCES FOR SURFACE ACCESSIBILITY.
- CURB RAMP STANDARDS INCLUDE:  
 424001 PERPENDICULAR CURB RAMPS FOR SIDEWALKS  
 424006 DIAGONAL CURB RAMPS FOR SIDEWALKS  
 424011 CORNER PARALLEL CURB RAMPS FOR SIDEWALKS  
 424021 DEPRESSED CORNER FOR SIDEWALKS  
 424026 ENTRANCE/ALLEY PEDESTRIAN CROSSINGS  
 424031 MEDIAN PEDESTRIAN CROSSINGS

LEGEND:

- DETECTABLE WARNINGS
- LEVEL LANDING (MAX. GRADE = 2.0%)
- RAMP RUNNING SLOPE (MAX. SLOPE = 1:12) (MAX LENGTH = 15')
- 6" WIDE CURB, VARIABLE HEIGHT (INCLUDED IN PAYMENT FOR PCC SIDEWALK)
- RUNNING SLOPE (MAX. SLOPE = 1:20)
- 4' x 4' CLEAR MANEUVERING AREA
- EXISTING R.O.W.
- PROPOSED R.O.W.

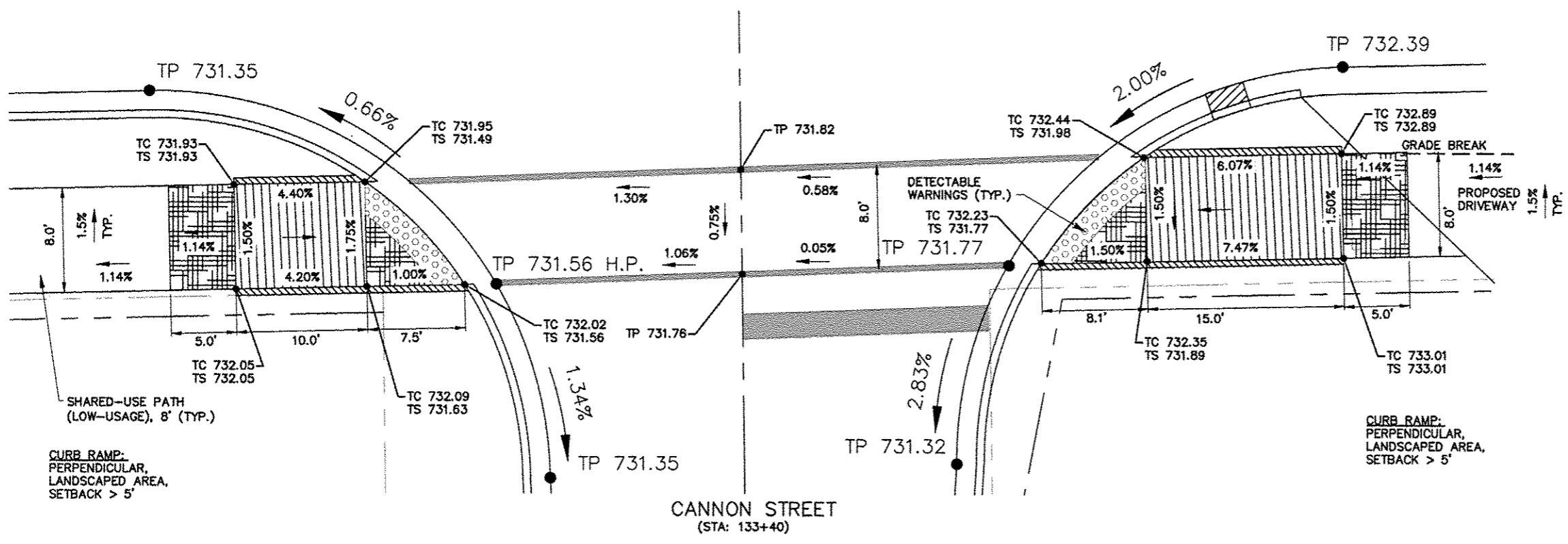
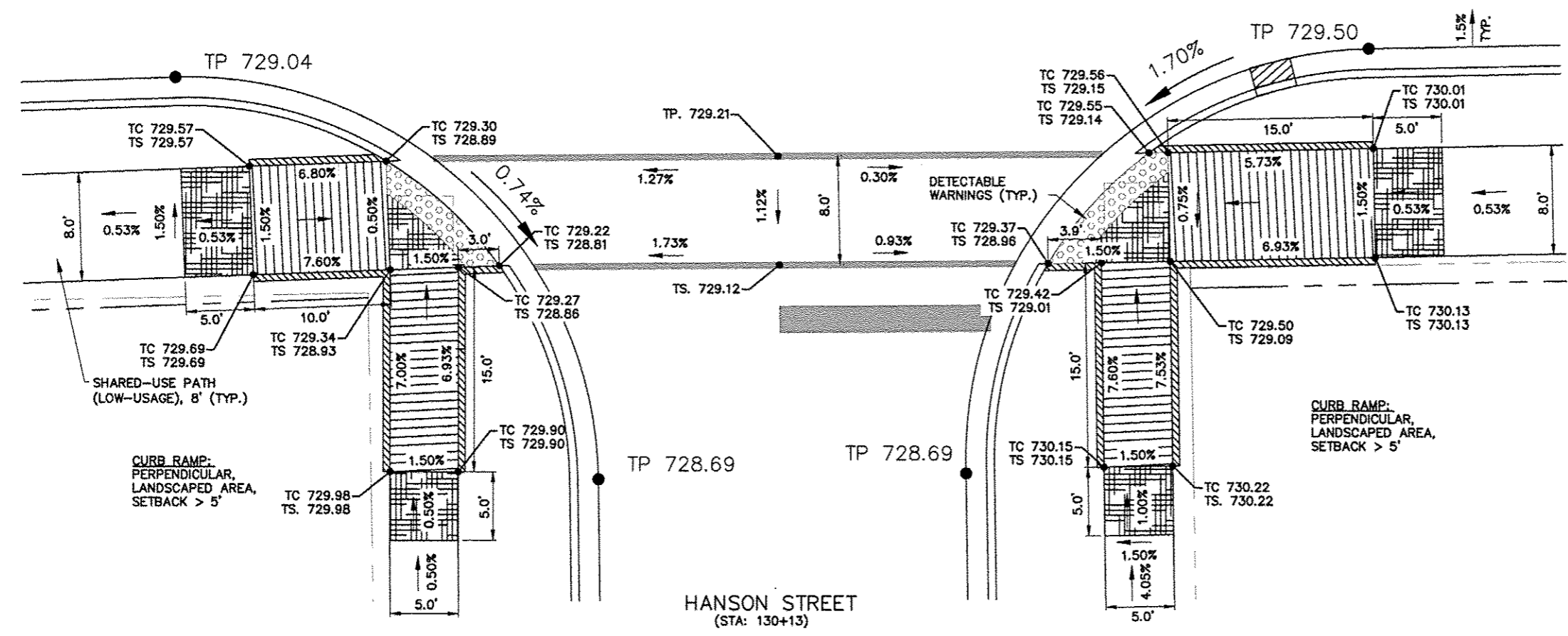

| REV. NO. | DESCRIPTION | DATE |
|----------|-------------|------|
|          |             |      |
|          |             |      |
|          |             |      |

|             |                |                    |
|-------------|----------------|--------------------|
| F.A.P. RTE. | SECTION        | COUNTY             |
| 525         | 01-00509-00-RP | WINNEBAGO          |
| ILLINOIS    |                | CONTRACT NO. 85612 |



SCALE:  
 PLAN: 1" = 5'  
 0 5 10  
 Scale in Feet

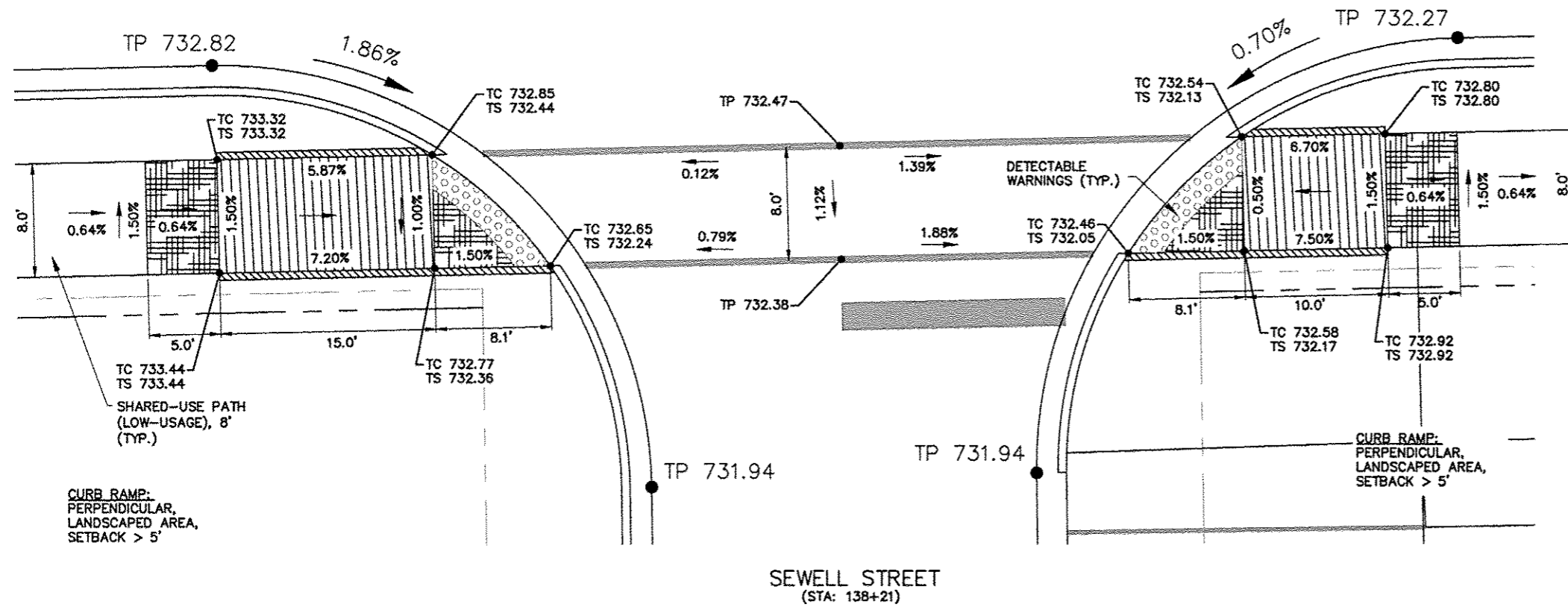

GENERAL NOTES:

- 1) ALL DETECTABLE WARNINGS ARE 24" WIDE.
- 2) ALL RAMP SLOPES GREATER THAN 1:20 REQUIRE AN UPPER LEVEL LANDING A MINIMUM OF 5' LONG. UPPER LEVEL LANDINGS ARE NOT REQUIRED FOR RAMP SLOPES FLATTER THAN 1:20.
- 3) MAXIMUM SLOPE OF SIDEWALK RAMP SHALL NOT EXCEED 12:1. SIDEWALK RAMPS SHALL ALSO BE A MAXIMUM LENGTH OF 15 FEET.
- 4) 6" WIDE VARIABLE HEIGHT CURB ALONG SIDEWALK SHALL BE MEASURED AND PAID AS PORTLAND CEMENT CONCRETE SIDEWALK.
- 5) SPOT ELEVATIONS:  
 TS = TOP OF SIDEWALK OR SLAB  
 TC = TOP OF CURB  
 TP = TOP OF PAVEMENT  
 ME = MATCH EXISTING
- 6) PREFABRICATED DETECTABLE WARNINGS SHALL BE FIT TO THE BACK OF CURB WITH NO MORE THAN A 6" GAP BETWEEN THE PREFABRICATED TILE AND THE BACK OF CURB BY USING EITHER TAPERED OR RADIUS TILE.
- 7) CURB RAMPS SHALL COMPLY WITH "PROPOSED ACCESSIBILITY GUIDELINES FOR PEDESTRIAN FACILITIES IN THE PUBLIC RIGHT-OF-WAY", LATEST EDITION, PUBLISHED BY THE U.S. ACCESS BOARD AND THE FINAL REPORT OF THE US ACCESS BOARD PUBLISHED JANUARY 2011 ENTITLED, "INITIATIVE ON DIMENSIONAL TOLERANCES IN CONSTRUCTION, DIMENSIONAL TOLERANCES FOR SURFACE ACCESSIBILITY.
- 8) CURB RAMP STANDARDS INCLUDE:  
 424001 PERPENDICULAR CURB RAMPS FOR SIDEWALKS  
 424006 DIAGONAL CURB RAMPS FOR SIDEWALKS  
 424011 CORNER PARALLEL CURB RAMPS FOR SIDEWALKS  
 424021 DEPRESSED CORNER FOR SIDEWALKS  
 424026 ENTRANCE/ALLEY PEDESTRIAN CROSSINGS  
 424031 MEDIAN PEDESTRIAN CROSSINGS

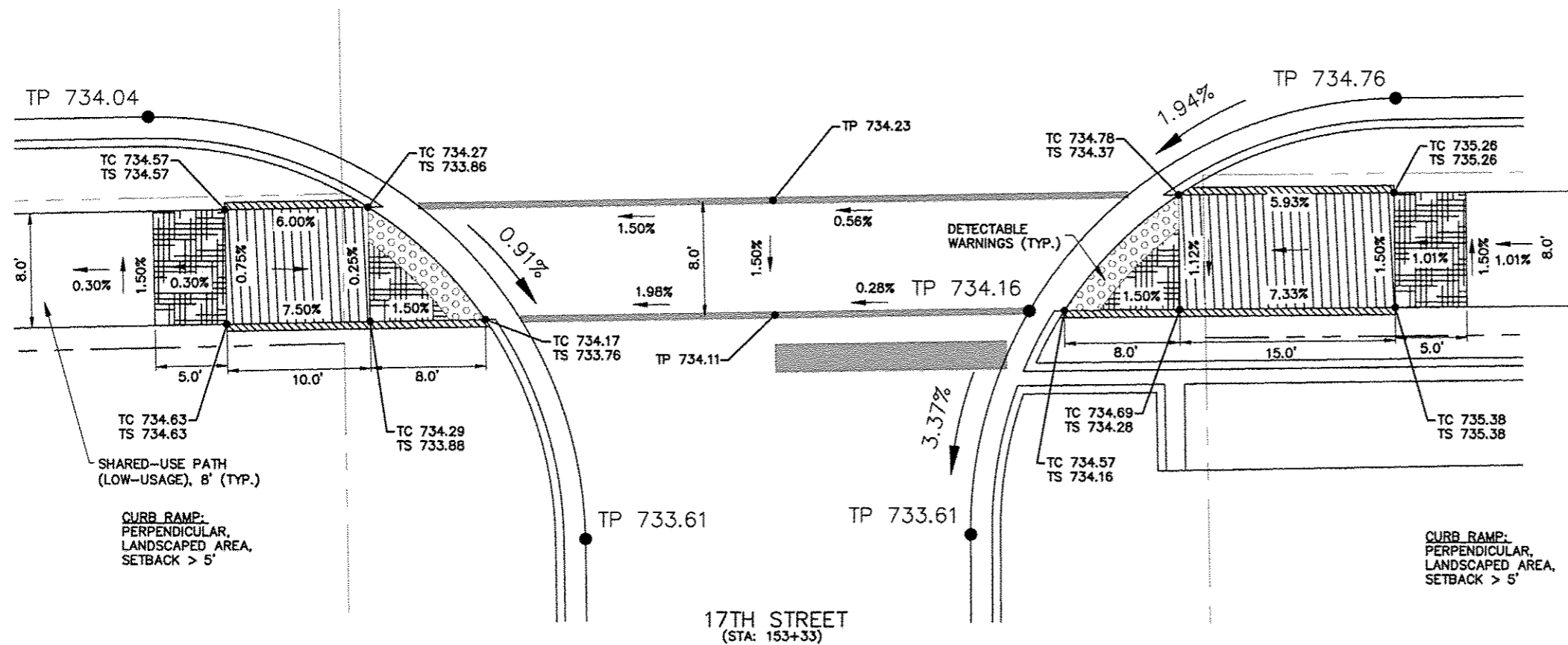

LEGEND:

- DETECTABLE WARNINGS
- LEVEL LANDING (MAX. GRADE = 2.0%)
- RAMP RUNNING SLOPE (MAX. SLOPE = 1:12) (MAX LENGTH = 15')
- 6" WIDE CURB, VARIABLE HEIGHT (INCLUDED FOR PAYMENT WITH PCC SIDEWALK)
- RUNNING SLOPE (MAX. SLOPE = 1:20)
- 4' X 4' CLEAR MANEUVERING AREA
- EXISTING R.O.W.
- PROPOSED R.O.W.

| REVISIONS |             |      |
|-----------|-------------|------|
| REV. NO.  | DESCRIPTION | DATE |
|           |             |      |
|           |             |      |
|           |             |      |

|                                     |                            |
|-------------------------------------|----------------------------|
| DRAWING<br>ADA CURB RAMP DETAILS 10 | JOB NUMBER<br>13-1070      |
|                                     | SHEET NUMBER<br>303 of 588 |

|             |                |                    |
|-------------|----------------|--------------------|
| F.A.P. RTE. | SECTION        | COUNTY             |
| 525         | 01-00509-00-RP | WINNEBAGO          |
| ILLINOIS    |                | CONTRACT NO. 85612 |



SCALE:  
PLAN: 1" = 5'  
0 5 10  
Scale in Feet

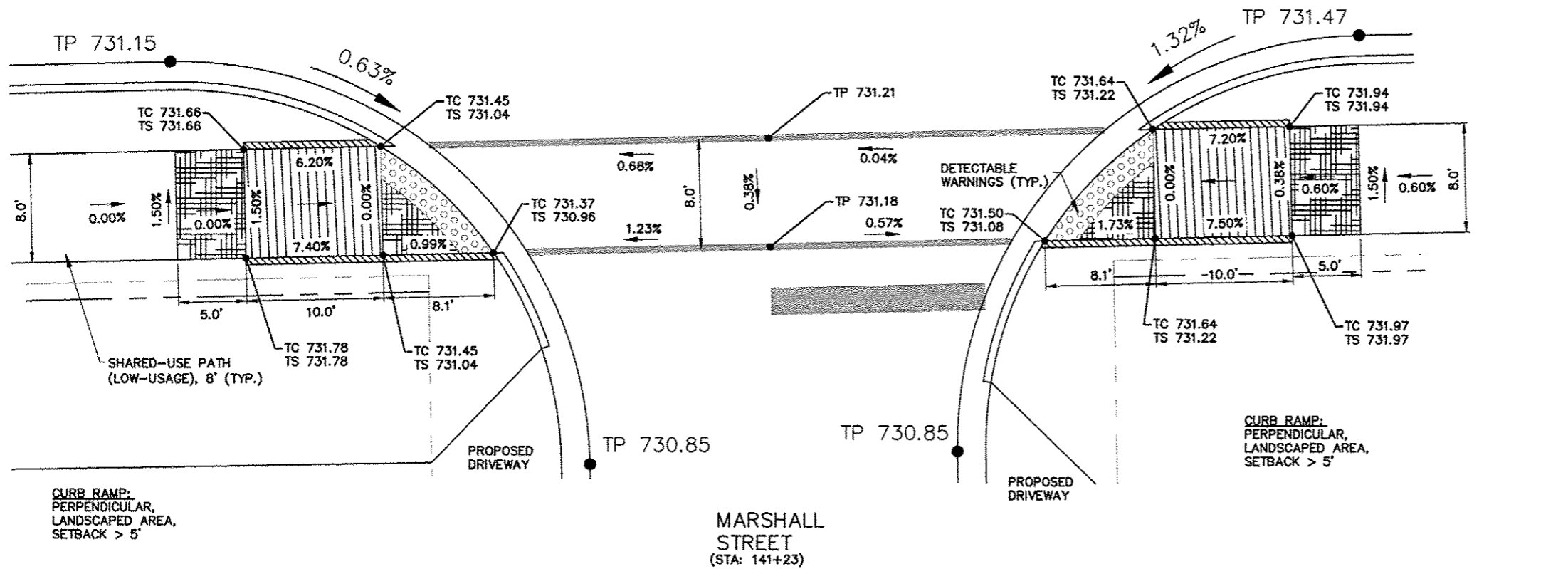

GENERAL NOTES:

- ALL DETECTABLE WARNINGS ARE 24" WIDE.
- ALL RAMP SLOPES GREATER THAN 1:20 REQUIRE AN UPPER LEVEL LANDING A MINIMUM OF 5' LONG. UPPER LEVEL LANDINGS ARE NOT REQUIRED FOR RAMP SLOPES FLATTER THAN 1:20.
- MAXIMUM SLOPE OF SIDEWALK RAMP SHALL NOT EXCEED 12:1. SIDEWALK RAMP SHALL ALSO BE A MAXIMUM LENGTH OF 15 FEET.
- 6" WIDE VARIABLE HEIGHT CURB ALONG SIDEWALK SHALL BE MEASURED AND PAID AS PORTLAND CEMENT CONCRETE SIDEWALK.
- SPOT ELEVATIONS:  
TS = TOP OF SIDEWALK OR SLAB  
TC = TOP OF CURB  
TP = TOP OF PAVEMENT  
ME = MATCH EXISTING
- PREFABRICATED DETECTABLE WARNINGS SHALL BE FIT TO THE BACK OF CURB WITH NO MORE THAN A 6" GAP BETWEEN THE PREFABRICATED TILE AND THE BACK OF CURB BY USING EITHER TAPERED OR RADIUS TILE.
- CURB RAMPS SHALL COMPLY WITH "PROPOSED ACCESSIBILITY GUIDELINES FOR PEDESTRIAN FACILITIES IN THE PUBLIC RIGHT-OF-WAY", LATEST EDITION, PUBLISHED BY THE U.S. ACCESS BOARD AND THE FINAL REPORT OF THE US ACCESS BOARD PUBLISHED JANUARY 2011 ENTITLED, "INITIATIVE ON DIMENSIONAL TOLERANCES IN CONSTRUCTION, DIMENSIONAL TOLERANCES FOR SURFACE ACCESSIBILITY.
- CURB RAMP STANDARDS INCLUDE:  
424001 PERPENDICULAR CURB RAMPS FOR SIDEWALKS  
424006 DIAGONAL CURB RAMPS FOR SIDEWALKS  
424011 CORNER PARALLEL CURB RAMPS FOR SIDEWALKS  
424021 DEPRESSED CORNER FOR SIDEWALKS  
424026 ENTRANCE/ALLEY PEDESTRIAN CROSSINGS  
424031 MEDIAN PEDESTRIAN CROSSINGS

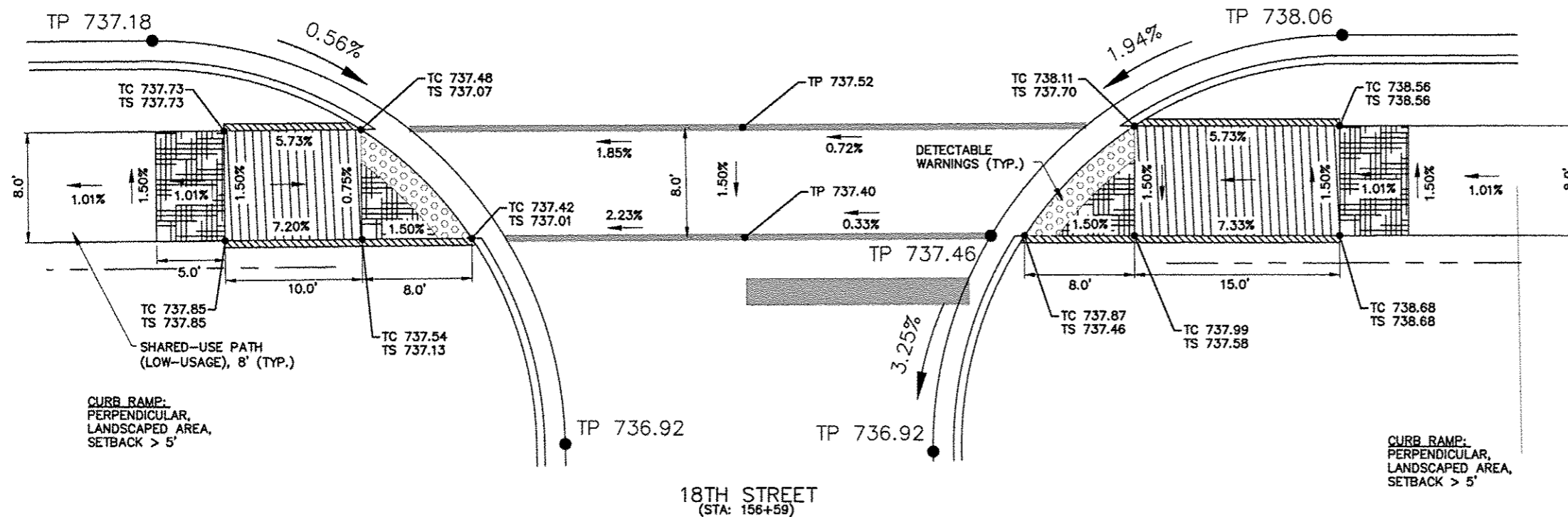

LEGEND:

- DETECTABLE WARNINGS
- LEVEL LANDING (MAX. GRADE = 2.0%)
- RAMP RUNNING SLOPE (MAX. SLOPE = 1:12) (MAX. LENGTH = 15')
- 6" WIDE CURB, VARIABLE HEIGHT (INCLUDED FOR PAYMENT WITH PCC SIDEWALK)
- RUNNING SLOPE (MAX. SLOPE = 1:20)
- 4' X 4' CLEAR MANEUVERING AREA
- EXISTING R.O.W.
- PROPOSED R.O.W.

| REV. NO. | DESCRIPTION | DATE |
|----------|-------------|------|
|          |             |      |
|          |             |      |
|          |             |      |
|          |             |      |

|             |                |                    |
|-------------|----------------|--------------------|
| F.A.P. RTE. | SECTION        | COUNTY             |
| 525         | 01-00509-00-RP | WINNEBAGO          |
| ILLINOIS    |                | CONTRACT NO. 85612 |



SCALE:  
PLAN: 1" = 5'  
0 5 10  
Scale in Feet

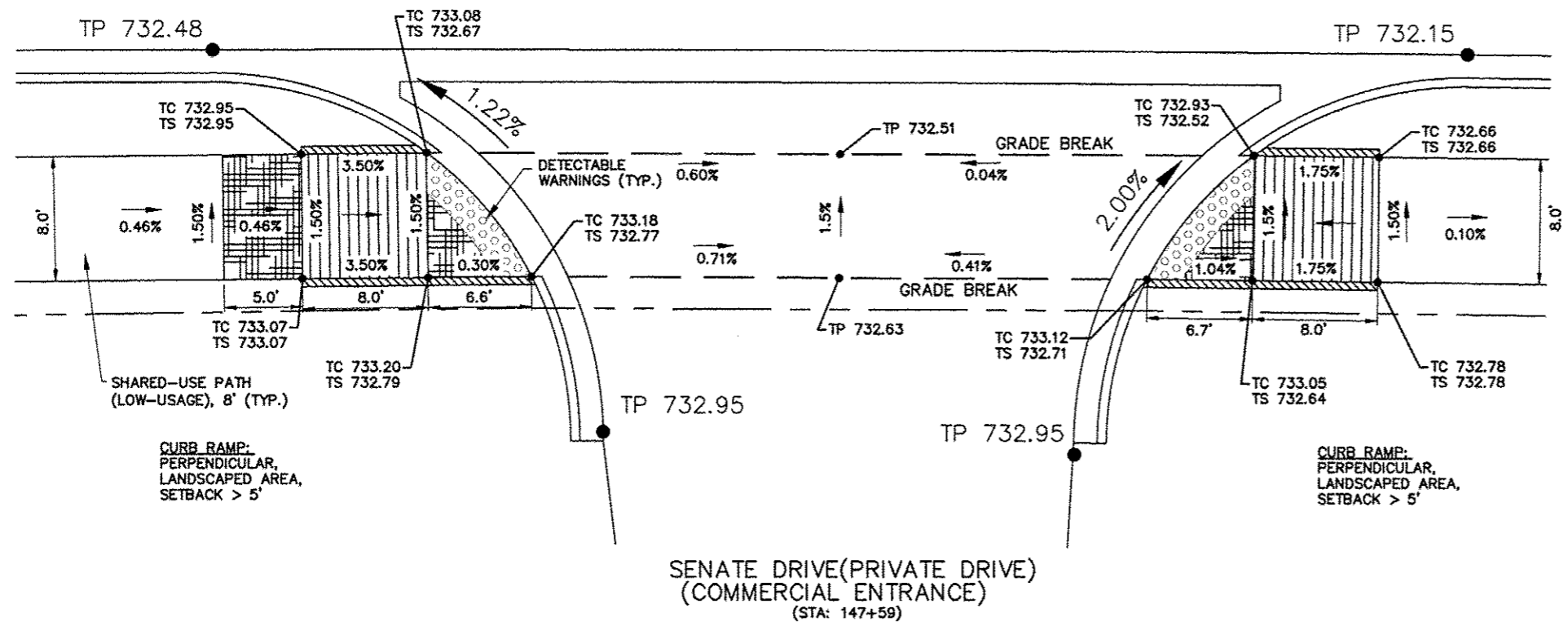

SENATE DRIVE (PRIVATE DRIVE)  
(COMMERCIAL ENTRANCE)  
(STA: 147+59)

- GENERAL NOTES:
- 1) ALL DETECTABLE WARNINGS ARE 24" WIDE.
  - 2) ALL RAMP SLOPES GREATER THAN 1:20 REQUIRE AN UPPER LEVEL LANDING A MINIMUM OF 5' LONG. UPPER LEVEL LANDINGS ARE NOT REQUIRED FOR RAMP SLOPES FLATTER THAN 1:20.
  - 3) MAXIMUM SLOPE OF SIDEWALK RAMP SHALL NOT EXCEED 12:1. SIDEWALK RAMPS SHALL ALSO BE A MAXIMUM LENGTH OF 15 FEET.
  - 4) 6" WIDE VARIABLE HEIGHT CURB ALONG SIDEWALK SHALL BE MEASURED AND PAID AS PORTLAND CEMENT CONCRETE SIDEWALK.
  - 5) SPOT ELEVATIONS:  
TS = TOP OF SIDEWALK OR SLAB  
TC = TOP OF CURB  
TP = TOP OF PAVEMENT  
ME = MATCH EXISTING
  - 6) PREFABRICATED DETECTABLE WARNINGS SHALL BE FIT TO THE BACK OF CURB WITH NO MORE THAN A 6" GAP BETWEEN THE PREFABRICATED TILE AND THE BACK OF CURB BY USING EITHER TAPERED OR RADIUS TILE.
  - 7) CURB RAMPS SHALL COMPLY WITH "PROPOSED ACCESSIBILITY GUIDELINES FOR PEDESTRIAN FACILITIES IN THE PUBLIC RIGHT-OF-WAY", LATEST EDITION, PUBLISHED BY THE U.S. ACCESS BOARD AND THE FINAL REPORT OF THE US ACCESS BOARD PUBLISHED JANUARY 2011 ENTITLED, "INITIATIVE ON DIMENSIONAL TOLERANCES IN CONSTRUCTION, DIMENSIONAL TOLERANCES FOR SURFACE ACCESSIBILITY.
  - 8) CURB RAMP STANDARDS INCLUDE:  
424001 PERPENDICULAR CURB RAMPS FOR SIDEWALKS  
424006 DIAGONAL CURB RAMPS FOR SIDEWALKS  
424011 CORNER PARALLEL CURB RAMPS FOR SIDEWALKS  
424021 DEPRESSED CORNER FOR SIDEWALKS  
424026 ENTRANCE/ALLEY PEDESTRIAN CROSSINGS  
424031 MEDIAN PEDESTRIAN CROSSINGS

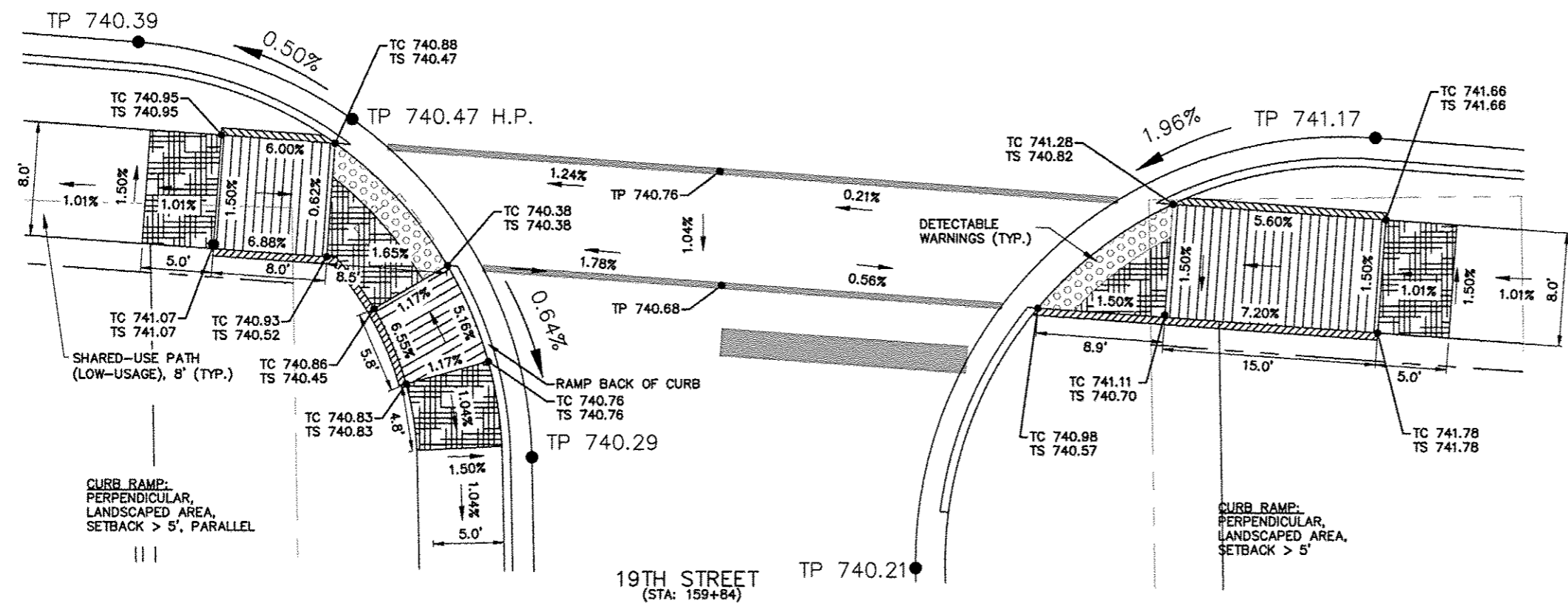

19TH STREET  
(STA: 159+84)

- LEGEND:
- DETECTABLE WARNINGS
  - LEVEL LANDING (MAX. GRADE = 2.0%)
  - RAMP RUNNING SLOPE (MAX. SLOPE = 1:12) (MAX. LENGTH = 15')
  - 6" WIDE CURB, VARIABLE HEIGHT (INCLUDED FOR PAYMENT WITH PCC SIDEWALK)
  - RUNNING SLOPE (MAX. SLOPE = 1:20)
  - 4' X 4' CLEAR MANEUVERING AREA
  - EXISTING R.O.W.
  - PROPOSED R.O.W.

| REVISIONS |             |      |
|-----------|-------------|------|
| REV. NO.  | DESCRIPTION | DATE |
|           |             |      |
|           |             |      |
|           |             |      |

|             |                |                    |
|-------------|----------------|--------------------|
| F.A.P. RTE. | SECTION        | COUNTY             |
| 525         | 01-00509-00-RP | WINNEBAGO          |
| ILLINOIS    |                | CONTRACT NO. 85612 |

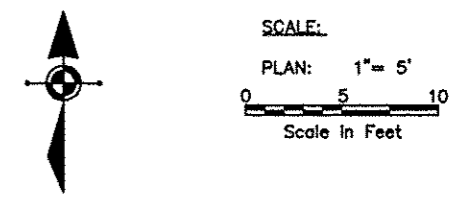
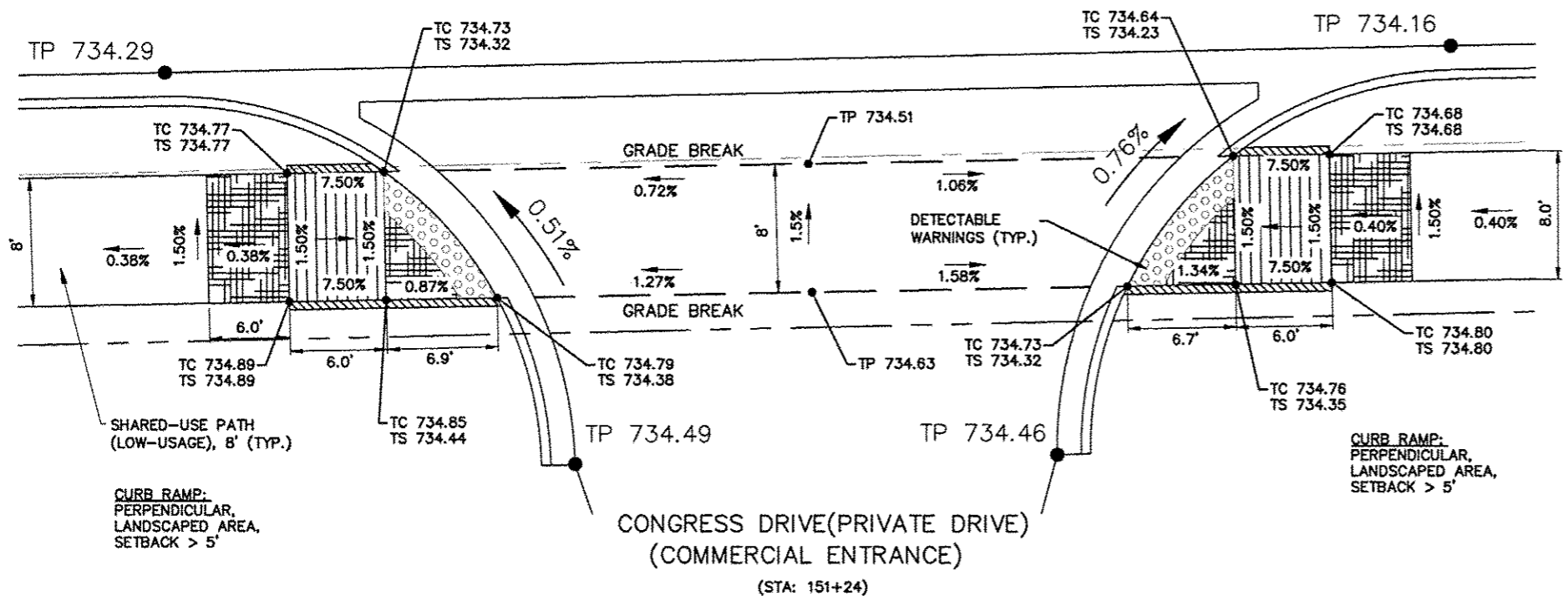

- GENERAL NOTES:
- 1) ALL DETECTABLE WARNINGS ARE 24" WIDE.
  - 2) ALL RAMP SLOPES GREATER THAN 1:20 REQUIRE AN UPPER LEVEL LANDING A MINIMUM OF 5' LONG. UPPER LEVEL LANDINGS ARE NOT REQUIRED FOR RAMP SLOPES FLATTER THAN 1:20.
  - 3) MAXIMUM SLOPE OF SIDEWALK RAMP SHALL NOT EXCEED 12:1. SIDEWALK RAMPS SHALL ALSO BE A MAXIMUM LENGTH OF 15 FEET.
  - 4) 6" WIDE VARIABLE HEIGHT CURB ALONG SIDEWALK SHALL BE MEASURED AND PAID AS PORTLAND CEMENT CONCRETE SIDEWALK.
  - 5) SPOT ELEVATIONS:  
 TS = TOP OF SIDEWALK OR SLAB  
 TC = TOP OF CURB  
 TP = TOP OF PAVEMENT  
 ME = MATCH EXISTING
  - 6) PREFABRICATED DETECTABLE WARNINGS SHALL BE FIT TO THE BACK OF CURB WITH NO MORE THAN A 6" GAP BETWEEN THE PREFABRICATED TILE AND THE BACK OF CURB BY USING EITHER TAPERED OR RADIUS TILE.
  - 7) CURB RAMPS SHALL COMPLY WITH "PROPOSED ACCESSIBILITY GUIDELINES FOR PEDESTRIAN FACILITIES IN THE PUBLIC RIGHT-OF-WAY", LATEST EDITION, PUBLISHED BY THE U.S. ACCESS BOARD AND THE FINAL REPORT OF THE US ACCESS BOARD PUBLISHED JANUARY 2011 ENTITLED, "INITIATIVE ON DIMENSIONAL TOLERANCES IN CONSTRUCTION, DIMENSIONAL TOLERANCES FOR SURFACE ACCESSIBILITY.
  - 8) CURB RAMP STANDARDS INCLUDE:  
 424001 PERPENDICULAR CURB RAMPS FOR SIDEWALKS  
 424006 DIAGONAL CURB RAMPS FOR SIDEWALKS  
 424011 CORNER PARALLEL CURB RAMPS FOR SIDEWALKS  
 424021 DEPRESSED CORNER FOR SIDEWALKS  
 424026 ENTRANCE/ALLEY PEDESTRIAN CROSSINGS  
 424031 MEDIAN PEDESTRIAN CROSSINGS

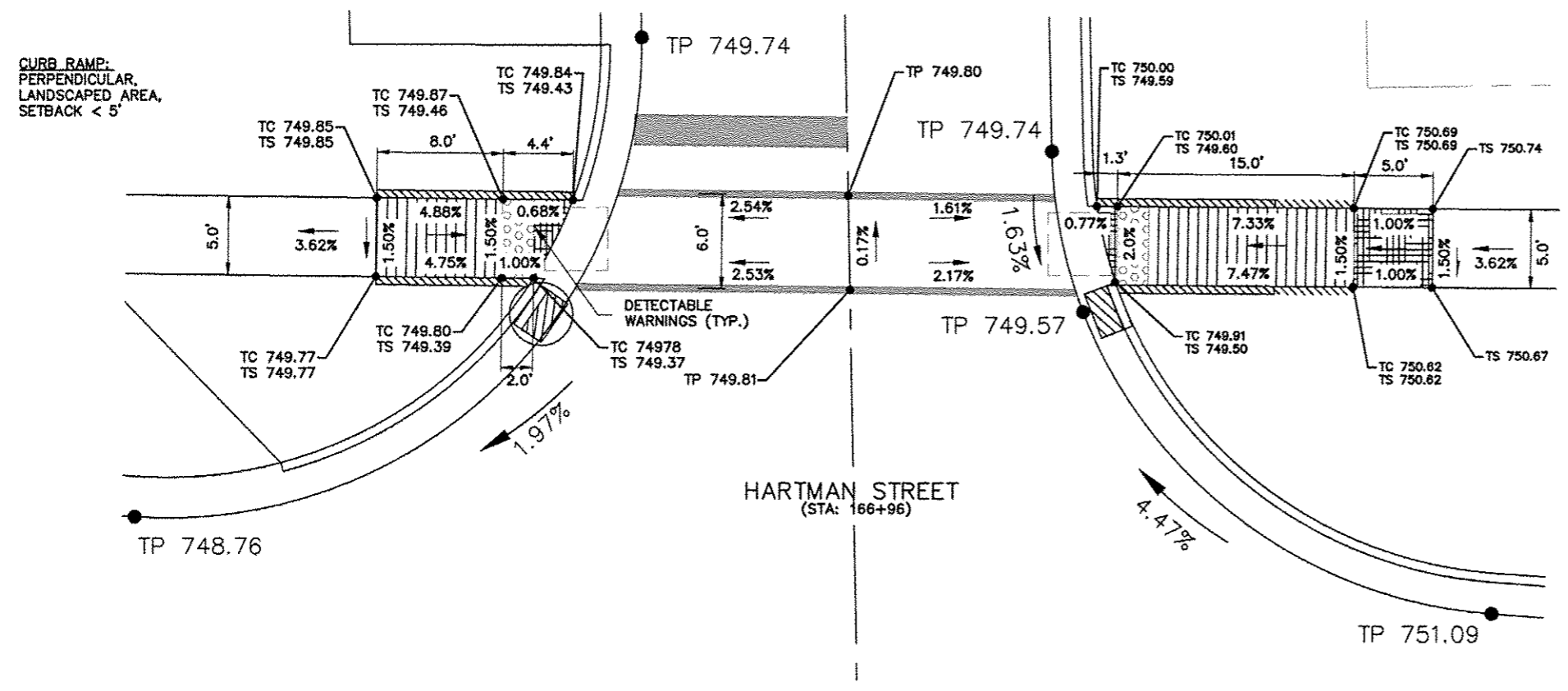

LEGEND:

|  |  |
|--|--|
|  | DETECTABLE WARNINGS  |
|  | LEVEL LANDING (MAX. GRADE = 2.0%)                                      |
|  | RAMP (MAX. SLOPE = 1:12)   |
|  | RUNNING SLOPE (MAX LENGTH = 15')                                       |
|  | 6" WIDE CURB, VARIABLE HEIGHT (INCLUDED FOR PAYMENT WITH PCC SIDEWALK) |
|  | RUNNING SLOPE (MAX. SLOPE = 1:20)                                      |
|  | 4' X 4' CLEAR MANEUVERING AREA   |
|  | EXISTING R.O.W.  |
|  | PROPOSED R.O.W.  |

| REVISIONS |             |      |
|-----------|-------------|------|
| REV. NO.  | DESCRIPTION | DATE |
|           |             |      |
|           |             |      |
|           |             |      |

|             |                |                    |
|-------------|----------------|--------------------|
| F.A.P. RTE. | SECTION        | COUNTY             |
| 525         | 01-00509-00-RP | WINNEBAGO          |
| ILLINOIS    |                | CONTRACT NO. 85612 |

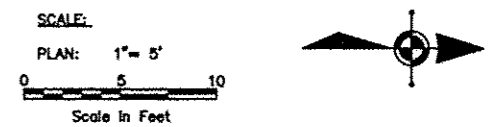

- GENERAL NOTES:
- 1) ALL DETECTABLE WARNINGS ARE 24" WIDE.
  - 2) ALL RAMP SLOPES GREATER THAN 1:20 REQUIRE AN UPPER LEVEL LANDING A MINIMUM OF 5' LONG. UPPER LEVEL LANDINGS ARE NOT REQUIRED FOR RAMP SLOPES FLATTER THAN 1:20.
  - 3) MAXIMUM SLOPE OF SIDEWALK RAMP SHALL NOT EXCEED 12:1. SIDEWALK RAMPS SHALL ALSO BE A MAXIMUM LENGTH OF 15 FEET.
  - 4) 6" WIDE VARIABLE HEIGHT CURB ALONG SIDEWALK SHALL BE MEASURED AND PAID AS PORTLAND CEMENT CONCRETE SIDEWALK.
  - 5) SPOT ELEVATIONS:  
TS = TOP OF SIDEWALK OR SLAB  
TC = TOP OF CURB  
TP = TOP OF PAVEMENT  
ME = MATCH EXISTING
  - 6) PREFABRICATED DETECTABLE WARNINGS SHALL BE FIT TO THE BACK OF CURB WITH NO MORE THAN A 6" GAP BETWEEN THE PREFABRICATED TILE AND THE BACK OF CURB BY USING EITHER TAPERED OR RADIUS TILE.
  - 7) CURB RAMPS SHALL COMPLY WITH "PROPOSED ACCESSIBILITY GUIDELINES FOR PEDESTRIAN FACILITIES IN THE PUBLIC RIGHT-OF-WAY", LATEST EDITION, PUBLISHED BY THE U.S. ACCESS BOARD AND THE FINAL REPORT OF THE US ACCESS BOARD PUBLISHED JANUARY 2011 ENTITLED, "INITIATIVE ON DIMENSIONAL TOLERANCES IN CONSTRUCTION, DIMENSIONAL TOLERANCES FOR SURFACE ACCESSIBILITY.
  - 8) CURB RAMP STANDARDS INCLUDE:  
424001 PERPENDICULAR CURB RAMPS FOR SIDEWALKS  
424006 DIAGONAL CURB RAMPS FOR SIDEWALKS  
424011 CORNER PARALLEL CURB RAMPS FOR SIDEWALKS  
424021 DEPRESSED CORNER FOR SIDEWALKS  
424026 ENTRANCE/ALLEY PEDESTRIAN CROSSINGS  
424031 MEDIAN PEDESTRIAN CROSSINGS

LEGEND:

|  |  |
|--|--|
|  | DETECTABLE WARNINGS  |
|  | LEVEL LANDING (MAX. GRADE = 2.0%)                                      |
|  | RAMP RUNNING SLOPE (MAX. SLOPE = 1:12) (MAX. LENGTH = 15')             |
|  | 6" WIDE CURB, VARIABLE HEIGHT (INCLUDED FOR PAYMENT WITH PCC SIDEWALK) |
|  | RAMP RUNNING SLOPE (MAX. SLOPE = 1:20)                                 |
|  | 4' X 4' CLEAR MANEUVERING AREA   |
|  | EXISTING R.O.W.  |
|  | PROPOSED R.O.W.  |

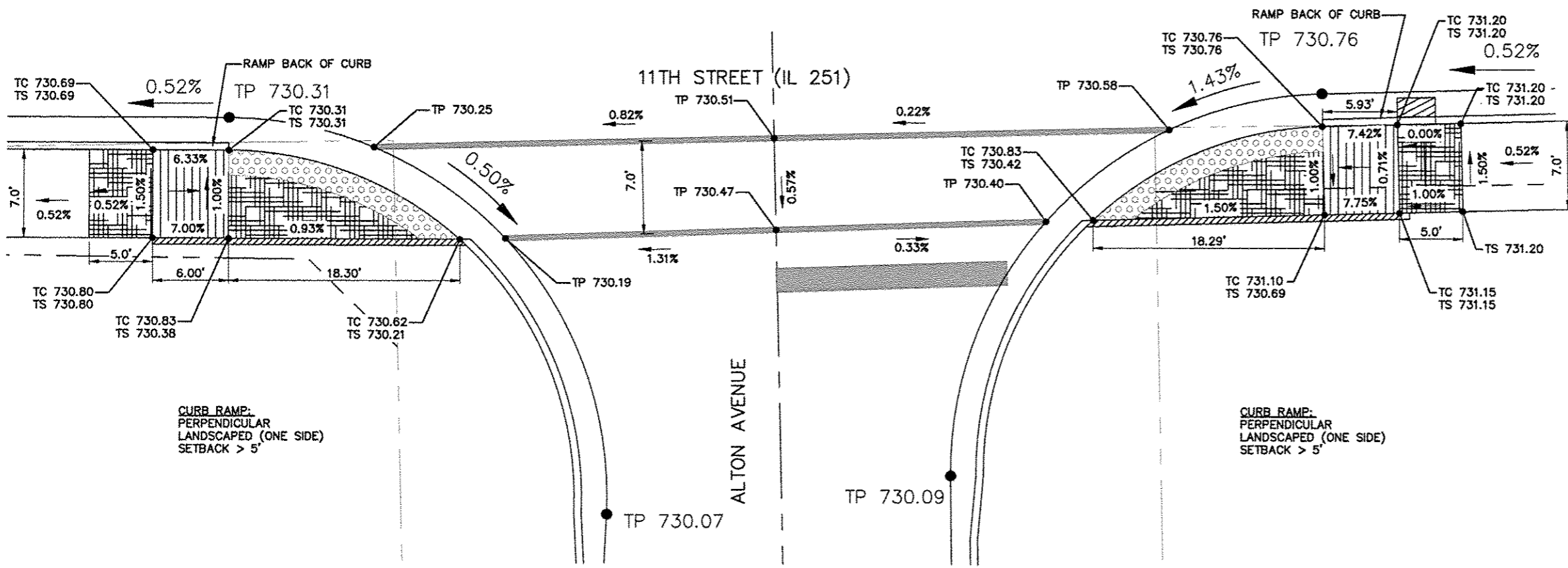
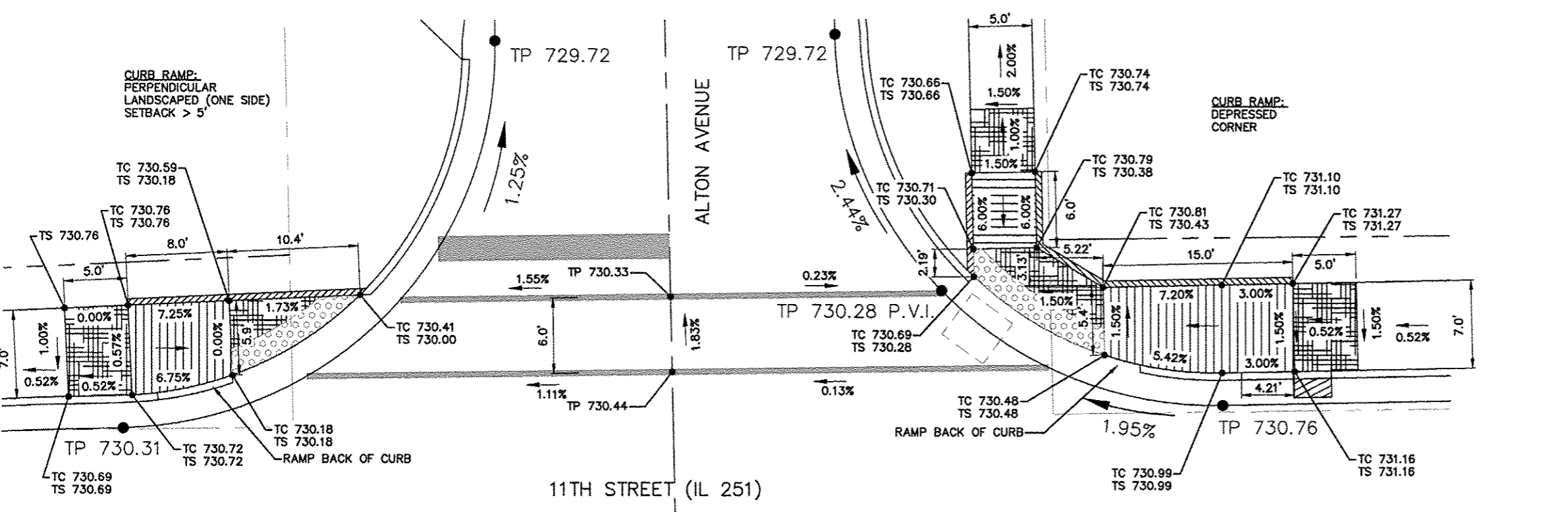

| REVISIONS |             |      |
|-----------|-------------|------|
| REV. NO.  | DESCRIPTION | DATE |
|           |             |      |
|           |             |      |
|           |             |      |

|                |                |                    |
|----------------|----------------|--------------------|
| F.A.P.<br>RTE. | SECTION        | COUNTY             |
| 525            | 01-00509-00-RP | WINNEBAGO          |
| ILLINOIS       |                | CONTRACT NO. 85612 |

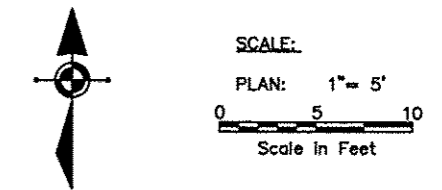

**GENERAL NOTES:**

- 1) ALL DETECTABLE WARNINGS ARE 24" WIDE.
- 2) ALL RAMP SLOPES GREATER THAN 1:20 REQUIRE AN UPPER LEVEL LANDING A MINIMUM OF 5' LONG. UPPER LEVEL LANDINGS ARE NOT REQUIRED FOR RAMP SLOPES FLATTER THAN 1:20.
- 3) MAXIMUM SLOPE OF SIDEWALK RAMP SHALL NOT EXCEED 12:1. SIDEWALK RAMPS SHALL ALSO BE A MAXIMUM LENGTH OF 15 FEET.
- 4) 6" WIDE VARIABLE HEIGHT CURB ALONG SIDEWALK SHALL BE MEASURED AND PAID AS PORTLAND CEMENT CONCRETE SIDEWALK.
- 5) SPOT ELEVATIONS:  
 TS = TOP OF SIDEWALK OR SLAB  
 TC = TOP OF CURB  
 TP = TOP OF PAVEMENT  
 ME = MATCH EXISTING
- 6) PREFABRICATED DETECTABLE WARNINGS SHALL BE FIT TO THE BACK OF CURB WITH NO MORE THAN A 6" GAP BETWEEN THE PREFABRICATED TILE AND THE BACK OF CURB BY USING EITHER TAPERED OR RADIUS TILE.
- 7) CURB RAMPS SHALL COMPLY WITH "PROPOSED ACCESSIBILITY GUIDELINES FOR PEDESTRIAN FACILITIES IN THE PUBLIC RIGHT-OF-WAY", LATEST EDITION, PUBLISHED BY THE U.S. ACCESS BOARD AND THE FINAL REPORT OF THE US ACCESS BOARD PUBLISHED JANUARY 2011 ENTITLED, "INITIATIVE ON DIMENSIONAL TOLERANCES IN CONSTRUCTION, DIMENSIONAL TOLERANCES FOR SURFACE ACCESSIBILITY.
- 8) CURB RAMP STANDARDS INCLUDE:  
 424001 PERPENDICULAR CURB RAMPS FOR SIDEWALKS  
 424006 DIAGONAL CURB RAMPS FOR SIDEWALKS  
 424011 CORNER PARALLEL CURB RAMPS FOR SIDEWALKS  
 424021 DEPRESSED CORNER FOR SIDEWALKS  
 424026 ENTRANCE/ALLEY PEDESTRIAN CROSSINGS  
 424031 MEDIAN PEDESTRIAN CROSSINGS

**LEGEND:**

|  |  |
|--|--|
|  | DETECTABLE WARNINGS  |
|  | LEVEL LANDING (MAX. GRADE = 2.0%)                                      |
|  | RAMP (MAX. SLOPE = 1:12) (MAX LENGTH = 15')                            |
|  | 6" WIDE CURB, VARIABLE HEIGHT (INCLUDED FOR PAYMENT WITH PCC SIDEWALK) |
|  | RUNNING SLOPE (MAX. SLOPE = 1:20)                                      |
|  | 4' X 4' CLEAR MANEUVERING AREA   |
|  | EXISTING R.O.W.  |
|  | PROPOSED R.O.W.  |

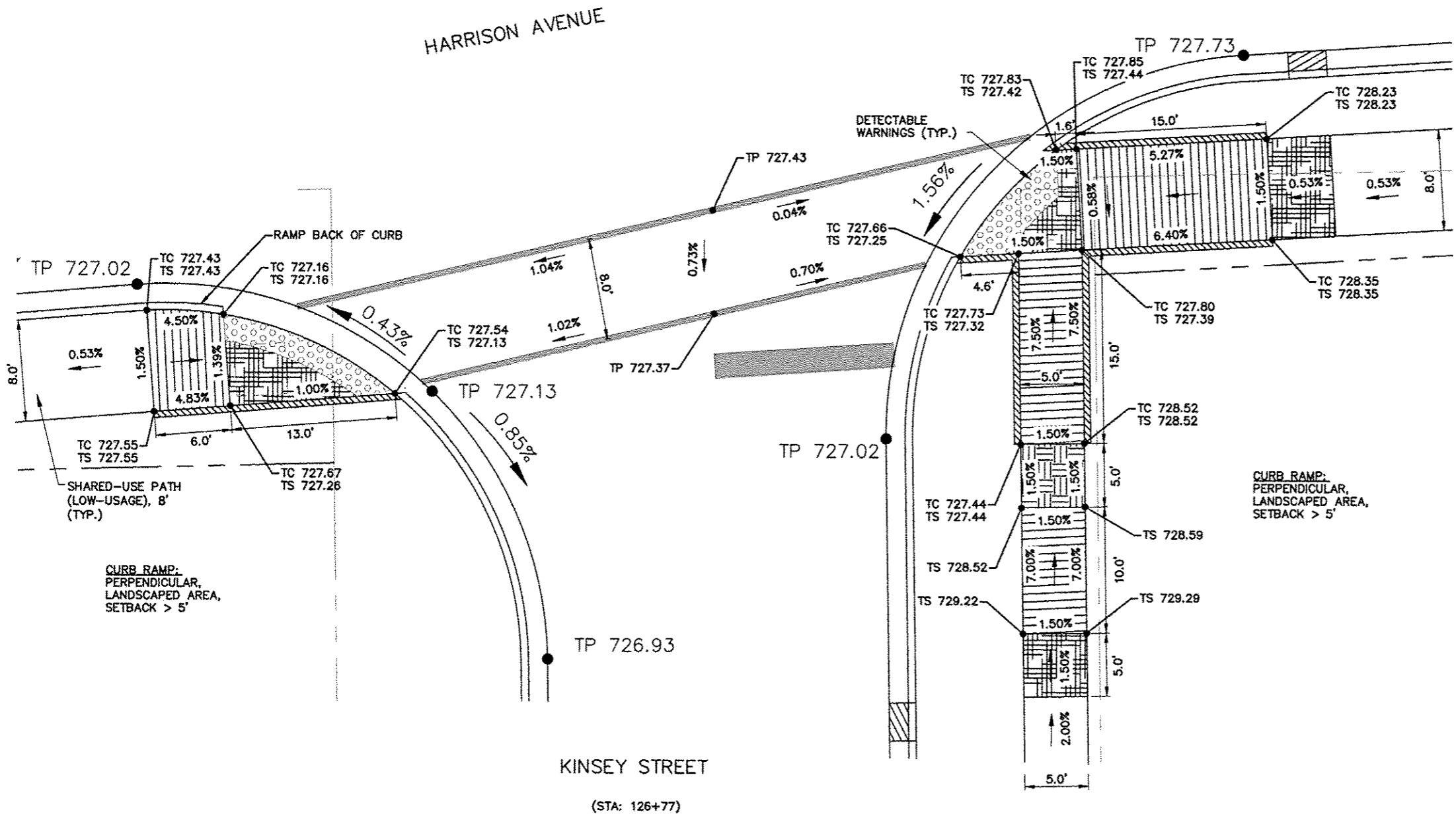

**FEHR GRAHAM**  
 ENGINEERING & ENVIRONMENTAL  
 ILLINOIS DESIGN FIRM NO. 184-003525  
 © 2014 FEHR GRAHAM

ILLINOIS  
 IOWA  
 WISCONSIN

**McClure**  
 Engineering Associates, Inc.  
 7282 Argus Drive  
 (615) 998-2337  
 Rockford, Illinois 61107-6637  
 FAX (815) 998-2496  
 Design Firm License: Illinois 164-000816  
 Copyright 2014 By McClure Engineering Associates, Inc.

**PROJECT AND LOCATION**  
 HARRISON AVENUE RECONSTRUCTION  
 IL 251 AND FAP 0525  
 11TH ST. TO 20TH ST.

**DRAWN BY:** RCS  
**APPROVED BY:** JWH  
**DATE:** 6/12/2015  
**SCALE:**

| REV. NO. | DESCRIPTION | DATE |
|----------|-------------|------|
|          |             |      |
|          |             |      |
|          |             |      |

**DRAWING**  
 ADA CURB RAMP DETAILS 15

**JOB NUMBER:**  
 13-1070

**SHEET NUMBER:**  
 308 of 588



|             |                |                    |
|-------------|----------------|--------------------|
| F.A.P. RTE. | SECTION        | COUNTY             |
| 525         | 01-00509-00-RP | WINNEBAGO          |
| ILLINOIS    |                | CONTRACT NO. 85612 |



SCALE:  
 PLAN: 1" = 5'  
 0 5 10  
 Scale in Feet

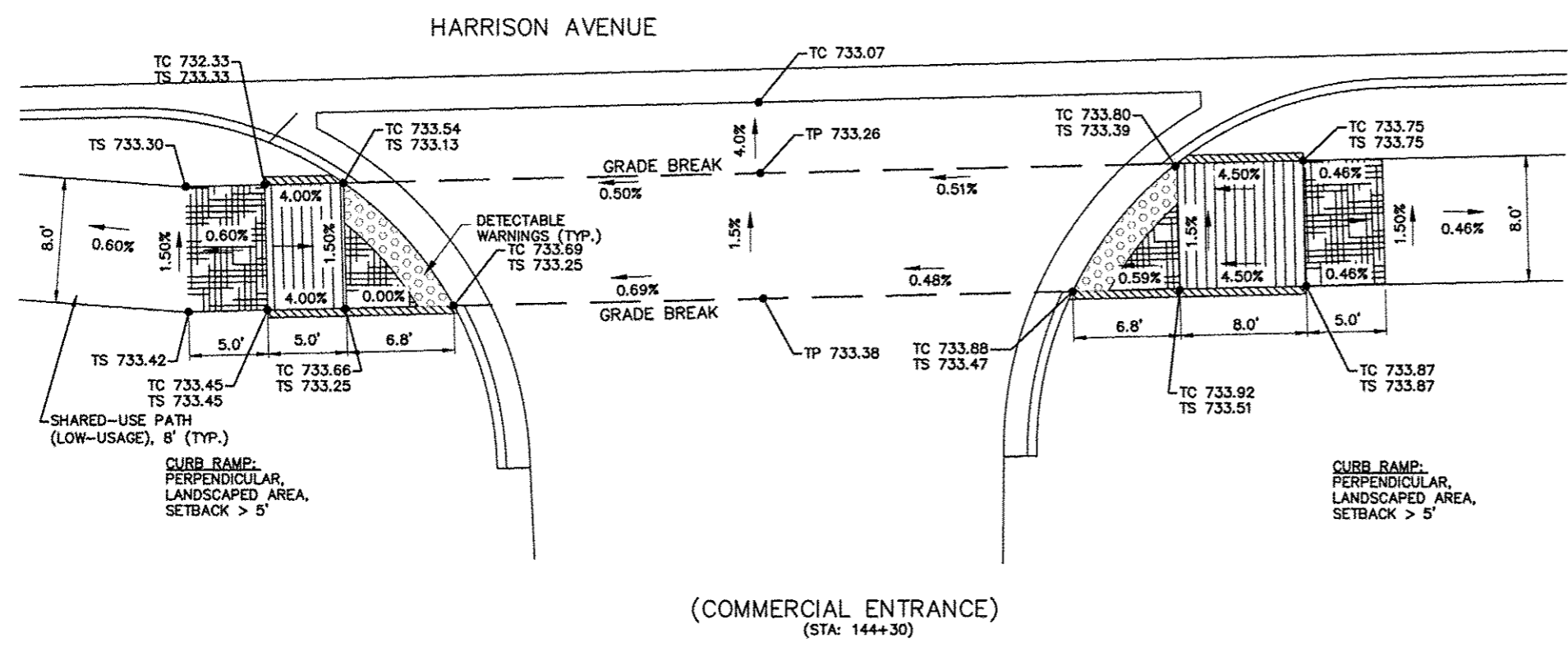

(COMMERCIAL ENTRANCE)  
 (STA: 144+30)

- GENERAL NOTES:
- 1) ALL DETECTABLE WARNINGS ARE 24" WIDE.
  - 2) ALL RAMP SLOPES GREATER THAN 1:20 REQUIRE AN UPPER LEVEL LANDING A MINIMUM OF 5' LONG. UPPER LEVEL LANDINGS ARE NOT REQUIRED FOR RAMP SLOPES FLATTER THAN 1:20.
  - 3) MAXIMUM SLOPE OF SIDEWALK RAMP SHALL NOT EXCEED 12:1. SIDEWALK RAMPS SHALL ALSO BE A MAXIMUM LENGTH OF 15 FEET.
  - 4) 6" WIDE VARIABLE HEIGHT CURB ALONG SIDEWALK SHALL BE MEASURED AND PAID AS PORTLAND CEMENT CONCRETE SIDEWALK.
  - 5) SPOT ELEVATIONS:  
 TS = TOP OF SIDEWALK OR SLAB  
 TC = TOP OF CURB  
 TP = TOP OF PAVEMENT  
 ME = MATCH EXISTING
  - 6) PREFABRICATED DETECTABLE WARNINGS SHALL BE FIT TO THE BACK OF CURB WITH NO MORE THAN A 6" GAP BETWEEN THE PREFABRICATED TILE AND THE BACK OF CURB BY USING EITHER TAPERED OR RADIUS TILE.
  - 7) CURB RAMPS SHALL COMPLY WITH "PROPOSED ACCESSIBILITY GUIDELINES FOR PEDESTRIAN FACILITIES IN THE PUBLIC RIGHT-OF-WAY", LATEST EDITION, PUBLISHED BY THE U.S. ACCESS BOARD AND THE FINAL REPORT OF THE US ACCESS BOARD PUBLISHED JANUARY 2011 ENTITLED, "INITIATIVE ON DIMENSIONAL TOLERANCES IN CONSTRUCTION, DIMENSIONAL TOLERANCES FOR SURFACE ACCESSIBILITY."
  - 8) CURB RAMP STANDARDS INCLUDE:  
 424001 PERPENDICULAR CURB RAMPS FOR SIDEWALKS  
 424006 DIAGONAL CURB RAMPS FOR SIDEWALKS  
 424011 CORNER PARALLEL CURB RAMPS FOR SIDEWALKS  
 424021 DEPRESSED CORNER FOR SIDEWALKS  
 424026 ENTRANCE/ALLEY PEDESTRIAN CROSSINGS  
 424031 MEDIAN PEDESTRIAN CROSSINGS

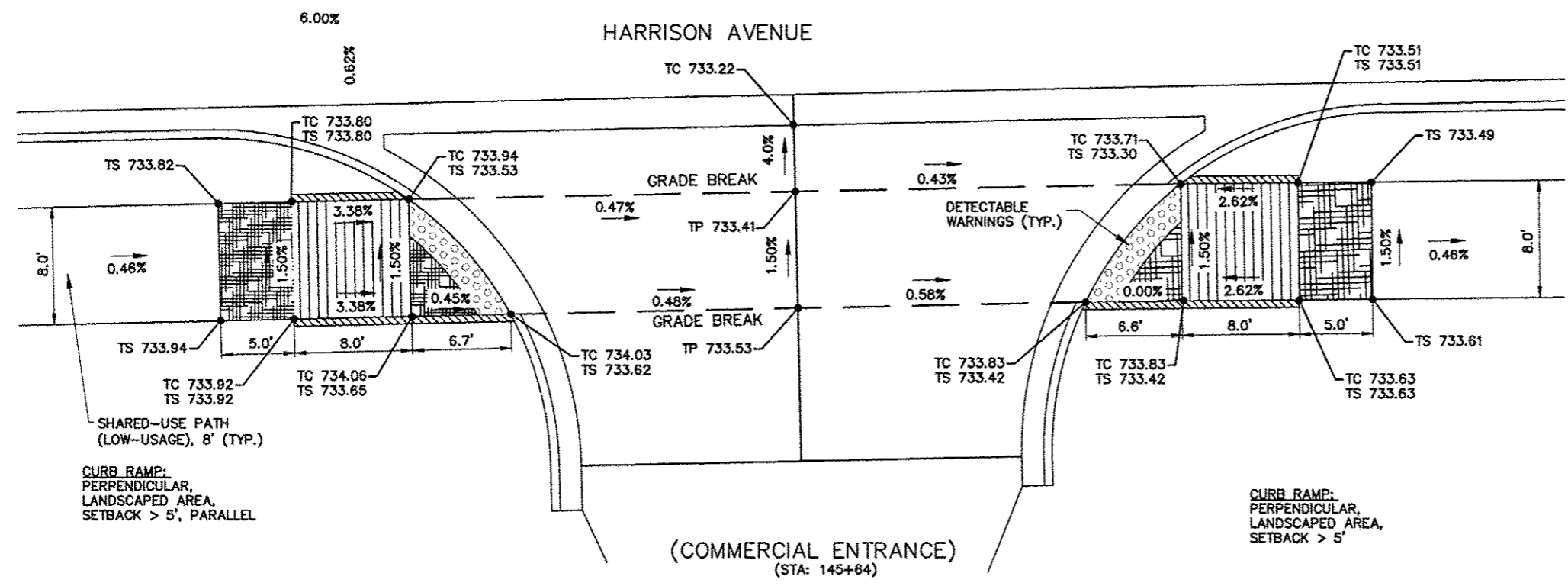

(COMMERCIAL ENTRANCE)  
 (STA: 145+64)

- LEGEND:
- DETECTABLE WARNINGS
  - LEVEL LANDING (MAX. GRADE = 2.0%)
  - RAMP RUNNING SLOPE (MAX. SLOPE = 1:12) (MAX. LENGTH = 15')
  - 6" WIDE CURB, VARIABLE HEIGHT (INCLUDED FOR PAYMENT WITH PCC SIDEWALK)
  - RUNNING SLOPE (MAX. SLOPE = 1:20)
  - 4' X 4' CLEAR MANEUVERING AREA
  - EXISTING R.O.W.
  - PROPOSED R.O.W.

| REV. NO. | DESCRIPTION | DATE |
|----------|-------------|------|
|          |             |      |
|          |             |      |
|          |             |      |

|             |                |                    |
|-------------|----------------|--------------------|
| F.A.P. RTE. | SECTION        | COUNTY             |
| 525         | 01-00509-00-RP | WINNEBAGO          |
| ILLINOIS    |                | CONTRACT NO. 85612 |

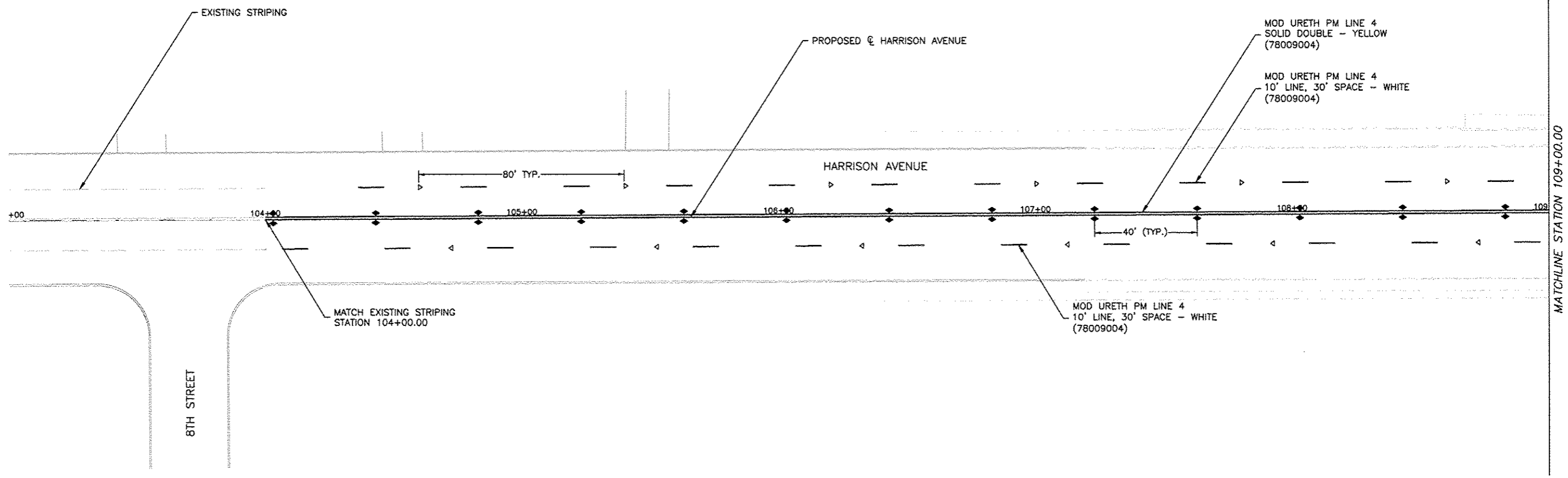

NOTE: ALL EXISTING PAVEMENT MARKINGS SHALL BE COMPLETELY REMOVED BEFORE APPLYING THE PROPOSED MODIFIED URETHANE PAVEMENT MARKINGS.

- SYMBOLS**
- ▶ ONE-WAY AMBER MARKER
  - ▷ ONE-WAY CRYSTAL MARKER
  - ◆ TWO-WAY AMBER MARKER
  - ⊕ STREET SIGN DESIGNATOR (SEE DETAILS)

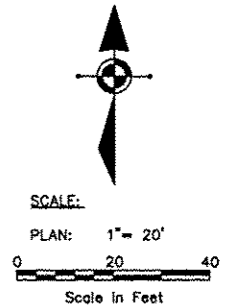

**FEHR GRAHAM**  
ENGINEERING & ENVIRONMENTAL  
ILLINOIS DESIGN FIRM NO. 184-003525  
© 2014 FEHR GRAHAM

ILLINOIS  
IOWA  
WISCONSIN

**McClure**  
Engineering Associates, Inc.  
7282 Argus Drive Rockford, Illinois 61107-5837  
(815) 398-2332 FAX (815) 398-2496  
Design Firm License: Illinois 184-000616  
Copyright 2014 By McClure Engineering Associates, Inc.

PROJECT AND LOCATION:  
HARRISON AVENUE RECONSTRUCTION  
IL 251 AND FAP 0525  
11TH ST. TO 20TH ST.

DRAWN BY: RCS  
APPROVED BY: JWH  
DATE: 6/12/2015  
SCALE:

| REVISIONS |             |      |
|-----------|-------------|------|
| REV. NO.  | DESCRIPTION | DATE |
|           |             |      |
|           |             |      |
|           |             |      |

DRAWING:  
PAVEMENT MARKING AND SIGNS

JOB NUMBER:  
13-1070  
SHEET NUMBER:  
310 of 588

|             |                |                    |
|-------------|----------------|--------------------|
| F.A.P. RTE. | SECTION        | COUNTY             |
| 525         | 01-00509-00-RP | WINNEBAGO          |
| ILLINOIS    |                | CONTRACT NO. 85612 |

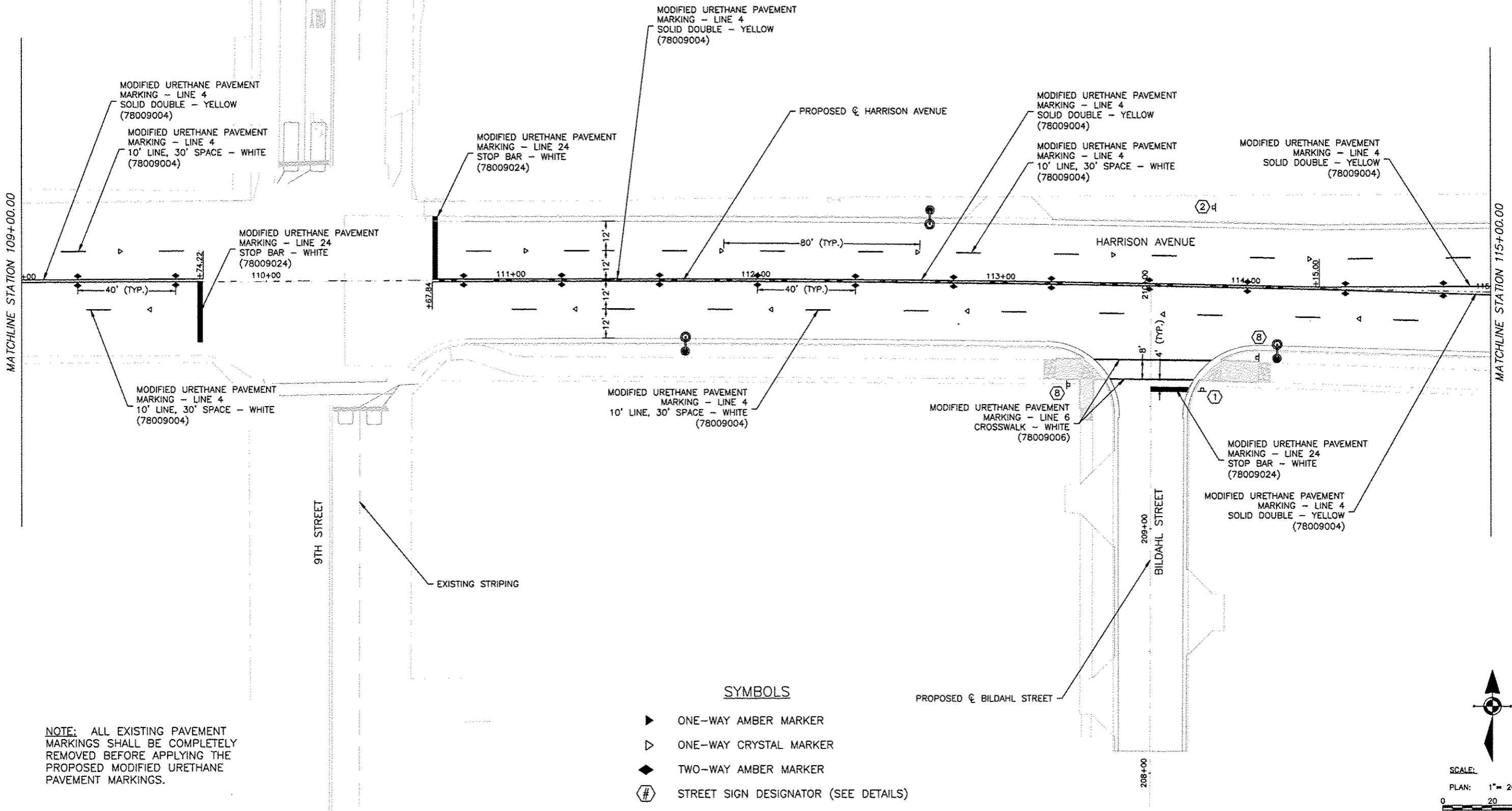

NOTE: ALL EXISTING PAVEMENT MARKINGS SHALL BE COMPLETELY REMOVED BEFORE APPLYING THE PROPOSED MODIFIED URETHANE PAVEMENT MARKINGS.

**SYMBOLS**

- ▶ ONE-WAY AMBER MARKER
- ▷ ONE-WAY CRYSTAL MARKER
- ◆ TWO-WAY AMBER MARKER
- # STREET SIGN DESIGNATOR (SEE DETAILS)

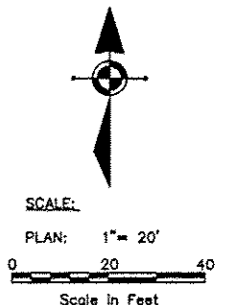

**FEHR GRAHAM**

ENGINEERING & ENVIRONMENTAL

ILLINOIS DESIGN FIRM NO. 184-003525  
© 2014 FEHR GRAHAM

ILLINOIS  
IOWA  
WISCONSIN

**McClure**  
Engineering Associates, Inc.  
7282 Argus Drive  
Rockford, Illinois 61107-6937  
(815) 398-2332 FAX (815) 398-2486  
Design Firm License: Illinois 124-000818  
Copyright 2014 By McClure Engineering Associates, Inc.

PROJECT AND LOCATION:  
HARRISON AVENUE RECONSTRUCTION  
IL 251 AND FAP 0525  
11TH ST. TO 20TH ST.

DRAWN BY: RCS  
APPROVED BY: JWH  
DATE: 6/12/2015  
SCALE:

| REVISIONS |             |      |
|-----------|-------------|------|
| REV. NO.  | DESCRIPTION | DATE |
|           |             |      |
|           |             |      |
|           |             |      |

DRAWING:  
PAVEMENT MARKING AND SIGNS

NS11-002 Harrison Ave - 11th St to 20th St, Harrison Ave - 1

JOB NUMBER:  
13-1070

SHEET NUMBER:  
311 of 588

|             |                |                    |
|-------------|----------------|--------------------|
| F.A.P. RTE. | SECTION        | COUNTY             |
| 525         | 01-00509-00-RP | WINNEBAGO          |
| ILLINOIS    |                | CONTRACT NO. 85612 |

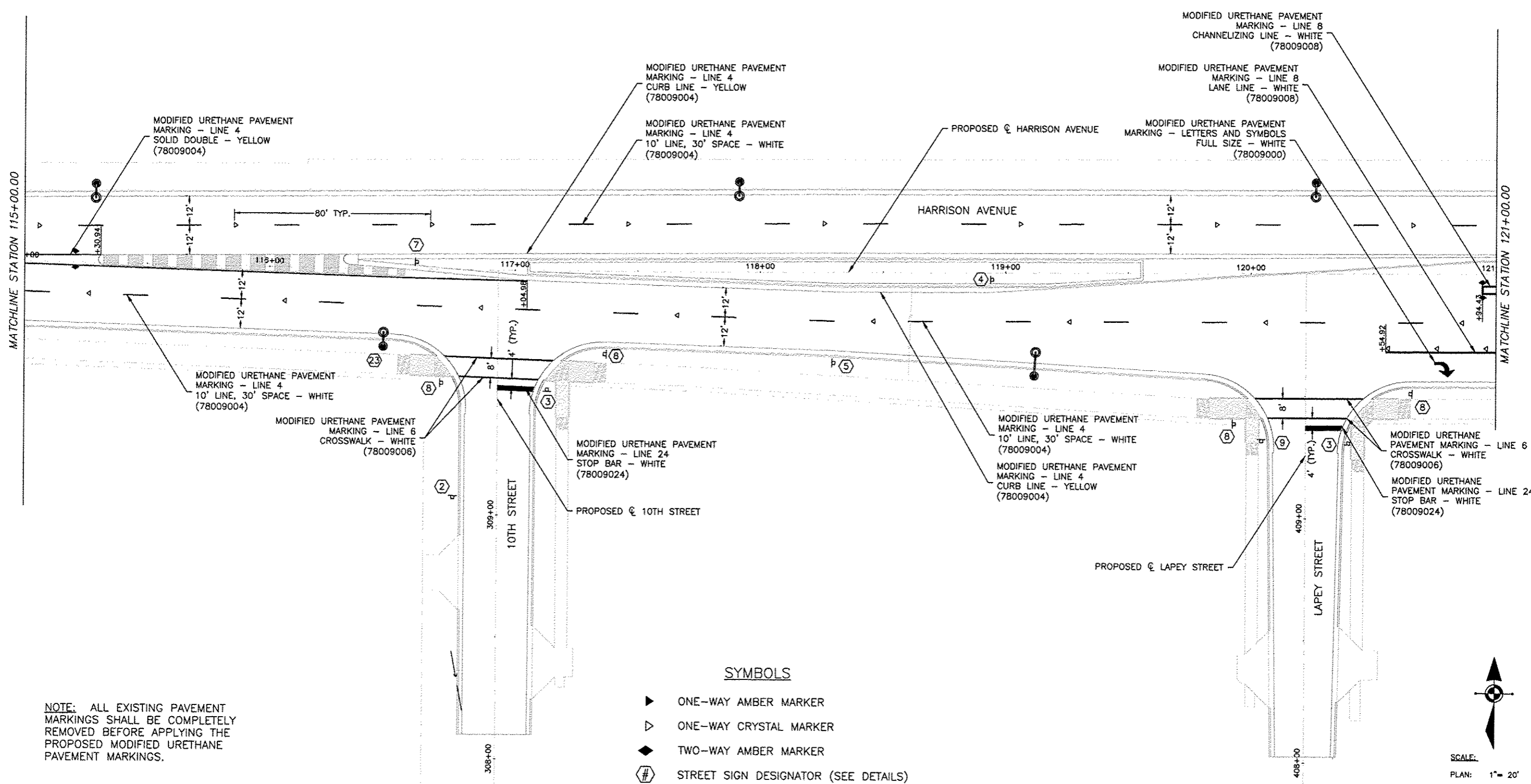

NOTE: ALL EXISTING PAVEMENT MARKINGS SHALL BE COMPLETELY REMOVED BEFORE APPLYING THE PROPOSED MODIFIED URETHANE PAVEMENT MARKINGS.

**SYMBOLS**

- ▶ ONE-WAY AMBER MARKER
- ▷ ONE-WAY CRYSTAL MARKER
- ◆ TWO-WAY AMBER MARKER
- # STREET SIGN DESIGNATOR (SEE DETAILS)

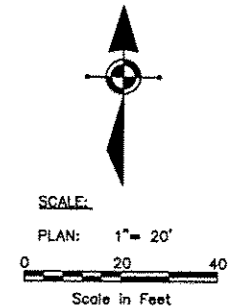

**FEHR GRAHAM**  
 ENGINEERING & ENVIRONMENTAL  
 ILLINOIS DESIGN FIRM NO. 184-003525  
 © 2014 FEHR GRAHAM

ILLINOIS  
 IOWA  
 WISCONSIN

**McClure**  
 Engineering Associates, Inc.  
 7262 Argus Drive  
 (815) 398-2332  
 Rockford, Illinois 61107-6837  
 FAX (815) 398-2488  
 Design Firm License: Illinois 184-000816  
 Copyright 2014 By McClure Engineering Associates, Inc.

PROJECT AND LOCATION:  
 HARRISON AVENUE RECONSTRUCTION  
 IL 251 AND FAP 0525  
 11TH ST. TO 20TH ST.

DRAWN BY: RCS  
 APPROVED BY: JWH  
 DATE: 6/12/2015  
 SCALE:

| REVISIONS |             |      |
|-----------|-------------|------|
| REV. NO.  | DESCRIPTION | DATE |
|           |             |      |
|           |             |      |
|           |             |      |

DRAWING:  
 PAVEMENT MARKING AND SIGNS

JOB NUMBER:  
 13-1070

SHEET NUMBER:  
 312 of 588

|             |                |                    |
|-------------|----------------|--------------------|
| F.A.P. RTE. | SECTION        | COUNTY             |
| 525         | 01-00509-00-RP | WINNEBAGO          |
| ILLINOIS    |                | CONTRACT NO. 85612 |

SEE 11TH STREET STRIPING PLANS

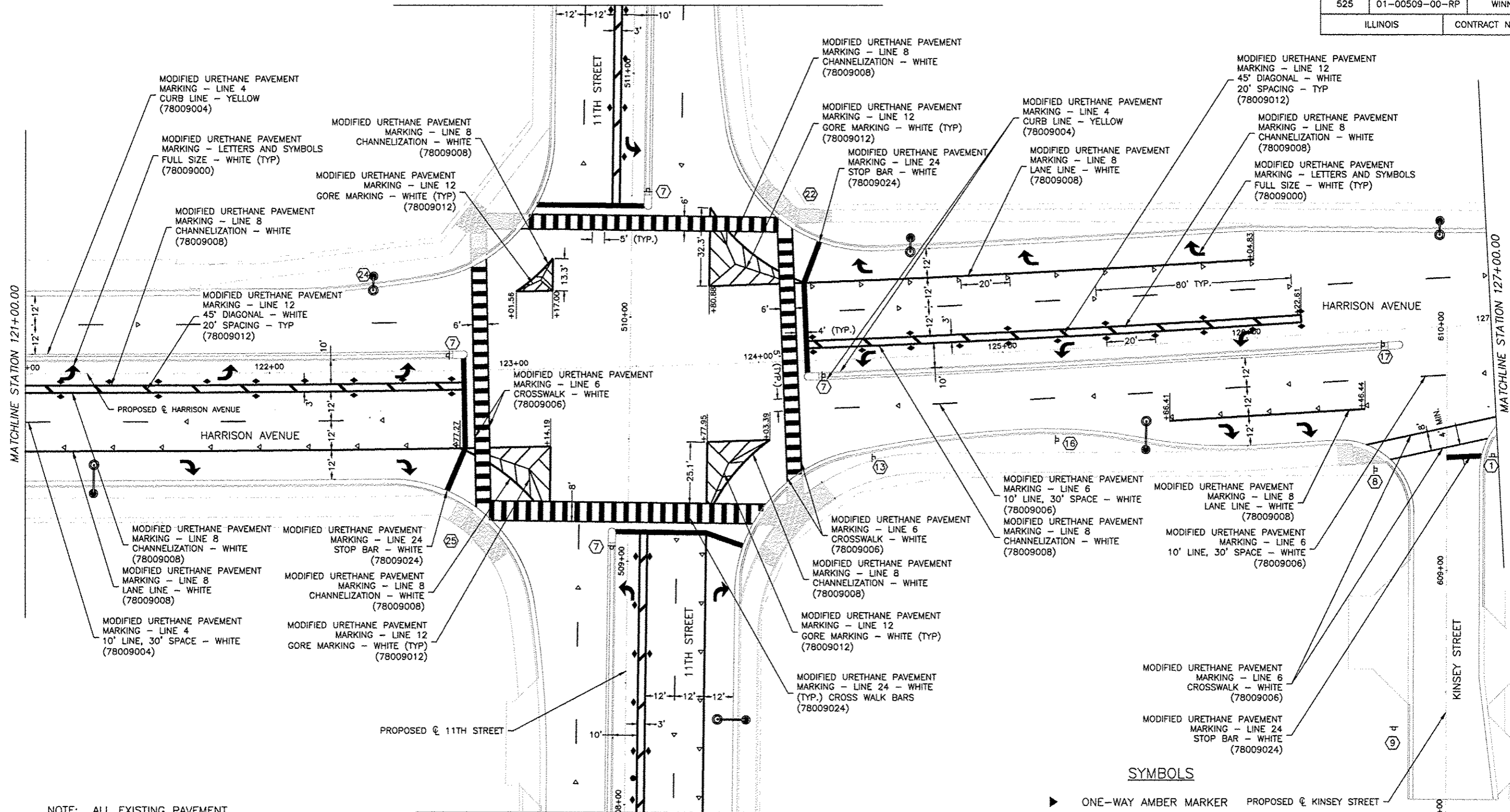

SEE 11TH STREET STRIPING PLANS

NOTE: ALL EXISTING PAVEMENT MARKINGS SHALL BE COMPLETELY REMOVED BEFORE APPLYING THE PROPOSED MODIFIED URETHANE PAVEMENT MARKINGS.

- SYMBOLS**
- ▶ ONE-WAY AMBER MARKER
  - ▷ ONE-WAY CRYSTAL MARKER
  - ◆ TWO-WAY AMBER MARKER
  - ⊕ STREET SIGN DESIGNATOR (SEE DETAILS)

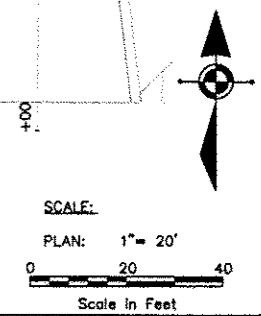

**FEHR GRAHAM**  
ENGINEERING & ENVIRONMENTAL  
ILLINOIS DESIGN FIRM NO. 184-003525  
© 2014 FEHR GRAHAM

ILLINOIS  
IOWA  
WISCONSIN

**McClure**  
Engineering Associates, Inc.  
7282 Argus Drive, Rookford, Illinois 61107-6837  
(815) 398-2332 FAX (815) 398-2496  
Design Firm License: Illinois 184-000818  
Copyright 2014 By McClure Engineering Associates, Inc.

PROJECT AND LOCATION:  
HARRISON AVENUE RECONSTRUCTION  
IL 251 AND FAP 0525  
11TH ST. TO 20TH ST.

DRAWN BY: RCS  
APPROVED BY: JWH  
DATE: 6/12/2015  
SCALE:

| REVISIONS |             |      |
|-----------|-------------|------|
| REV. NO.  | DESCRIPTION | DATE |
|           |             |      |
|           |             |      |
|           |             |      |

DRAWING:  
PAVEMENT MARKING AND SIGNS

JOB NUMBER:  
13-1070

SHEET NUMBER:  
313 of 588

|             |                |                    |
|-------------|----------------|--------------------|
| F.A.P. RTE. | SECTION        | COUNTY             |
| 525         | 01-00509-00-RP | WINNEBAGO          |
| ILLINOIS    |                | CONTRACT NO. 85612 |

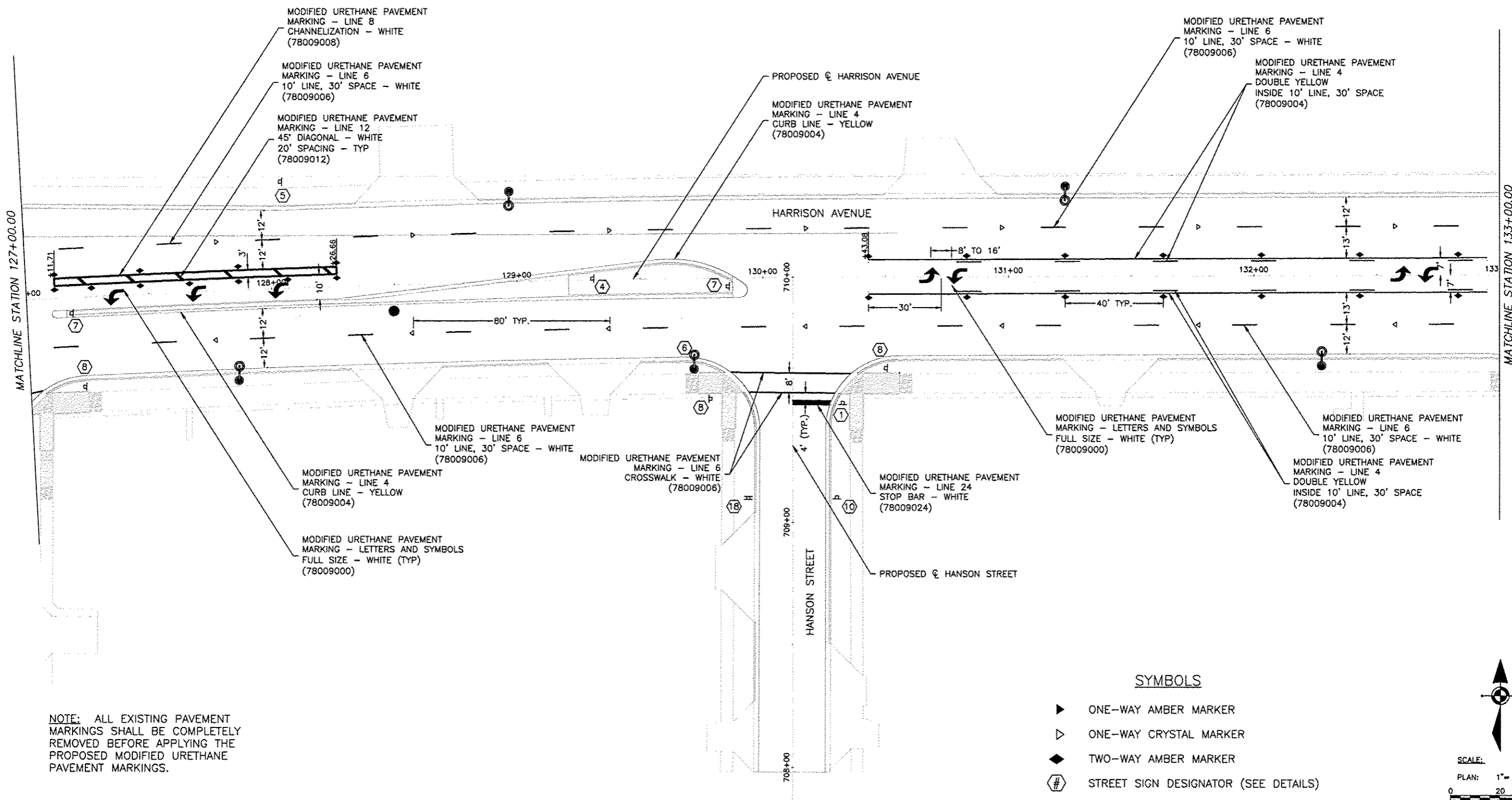

NOTE: ALL EXISTING PAVEMENT MARKINGS SHALL BE COMPLETELY REMOVED BEFORE APPLYING THE PROPOSED MODIFIED URETHANE PAVEMENT MARKINGS.

- SYMBOLS**
- ▶ ONE-WAY AMBER MARKER
  - ▷ ONE-WAY CRYSTAL MARKER
  - ◆ TWO-WAY AMBER MARKER
  - Ⓝ STREET SIGN DESIGNATOR (SEE DETAILS)

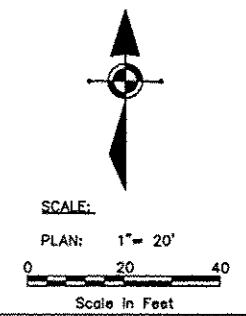

**FEHR GRAHAM**  
ENGINEERING & ENVIRONMENTAL  
ILLINOIS DESIGN FIRM NO. 184-003525  
© 2014 FEHR GRAHAM

ILLINOIS  
IOWA  
WISCONSIN

**McClure**  
Engineering Associates, Inc.  
7282 Argus Drive Rookford, Illinois 61107-6837  
(815) 398-2332 FAX (815) 398-2488  
Design Firm License: Illinois 184-000916  
Copyright 2014 By McClure Engineering Associates, Inc.

PROJECT AND LOCATION:  
HARRISON AVENUE RECONSTRUCTION  
IL 251 AND FAP 0525  
11TH ST. TO 20TH ST.

DRAWN BY: RCS  
APPROVED BY: JWH  
DATE: 6/12/2015  
SCALE:

| REVISIONS |             |      |
|-----------|-------------|------|
| REV. NO.  | DESCRIPTION | DATE |
|           |             |      |
|           |             |      |
|           |             |      |

DRAWING:  
PAVEMENT MARKING AND SIGNS

JOB NUMBER:  
13-1070  
SHEET NUMBER:  
314 of 588

|             |                |                    |
|-------------|----------------|--------------------|
| F.A.P. RTE. | SECTION        | COUNTY             |
| 525         | 01-00509-00-RP | WINNEBAGO          |
| ILLINOIS    |                | CONTRACT NO. 85612 |

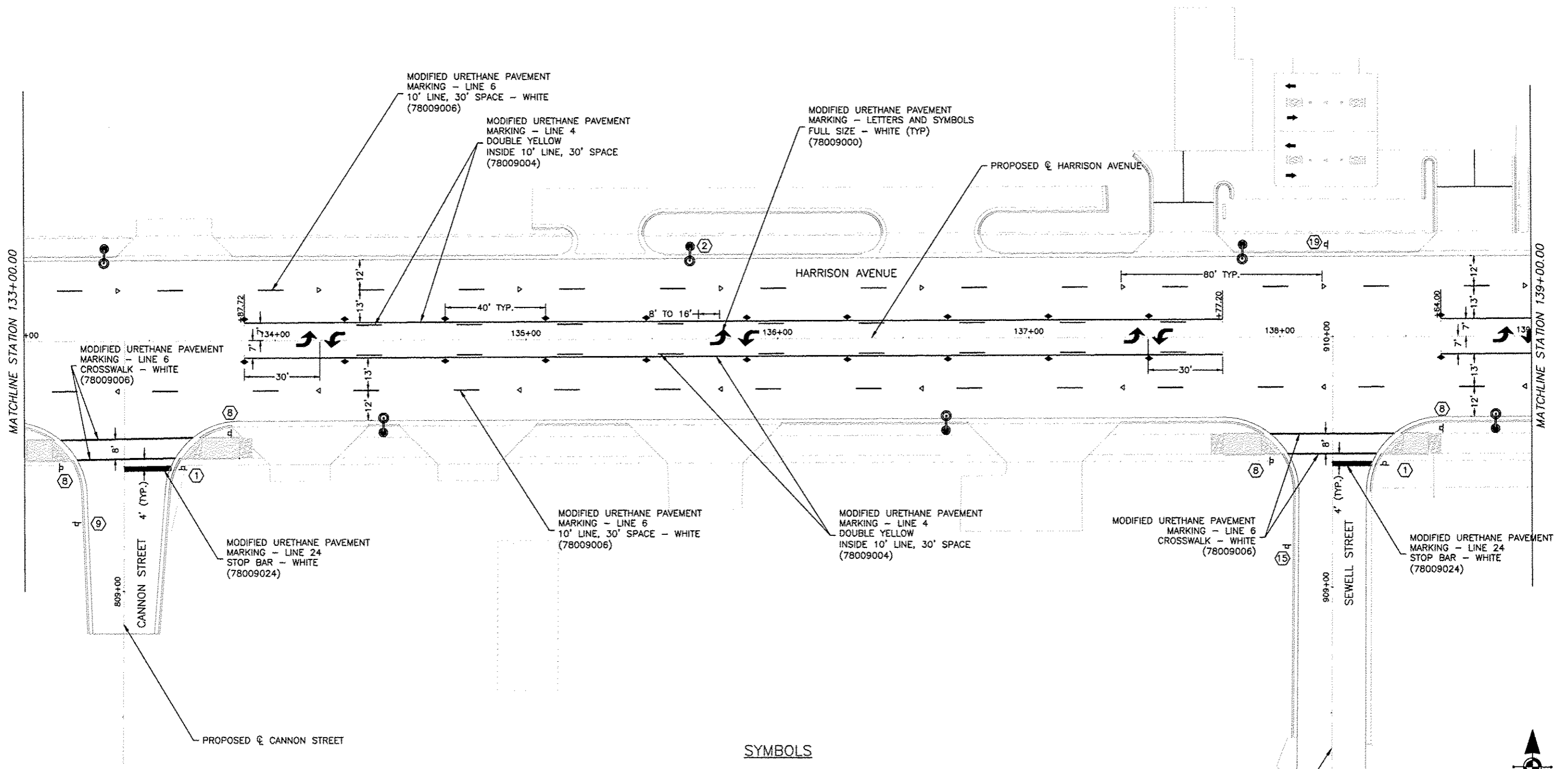

NOTE: ALL EXISTING PAVEMENT MARKINGS SHALL BE COMPLETELY REMOVED BEFORE APPLYING THE PROPOSED MODIFIED URETHANE PAVEMENT MARKINGS.

**SYMBOLS**

- ▶ ONE-WAY AMBER MARKER
- ▷ ONE-WAY CRYSTAL MARKER
- ◆ TWO-WAY AMBER MARKER
- Ⓝ STREET SIGN DESIGNATOR (SEE DETAILS)

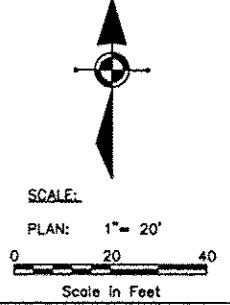

**FEHR GRAHAM**  
ENGINEERING & ENVIRONMENTAL  
ILLINOIS DESIGN FIRM NO. 184-003525

ILLINOIS  
IOWA  
WISCONSIN

**McClure**  
Engineering Associates, Inc.  
7282 Argus Drive Rookford, Illinois 61107-5837  
(815) 398-2332 FAX (815) 398-2486  
Design Firm License: Illinois 184-000816  
Copyright 2014 By McClure Engineering Associates, Inc.

PROJECT AND LOCATION:  
HARRISON AVENUE RECONSTRUCTION  
IL 251 AND FAP 0525  
11TH ST. TO 20TH ST.

DRAWN BY: RCS  
APPROVED BY: JWH  
DATE: 6/12/2015  
SCALE:

| REVISIONS |             |      |
|-----------|-------------|------|
| REV. NO.  | DESCRIPTION | DATE |
|           |             |      |
|           |             |      |
|           |             |      |

DRAWING:  
PAVEMENT MARKING AND SIGNS

JOB NUMBER:  
13-1070  
SHEET NUMBER:  
315 of 588

|             |                |                    |
|-------------|----------------|--------------------|
| F.A.P. RTE. | SECTION        | COUNTY             |
| 525         | 01-00509-00-RP | WINNEBAGO          |
| ILLINOIS    |                | CONTRACT NO. 85612 |

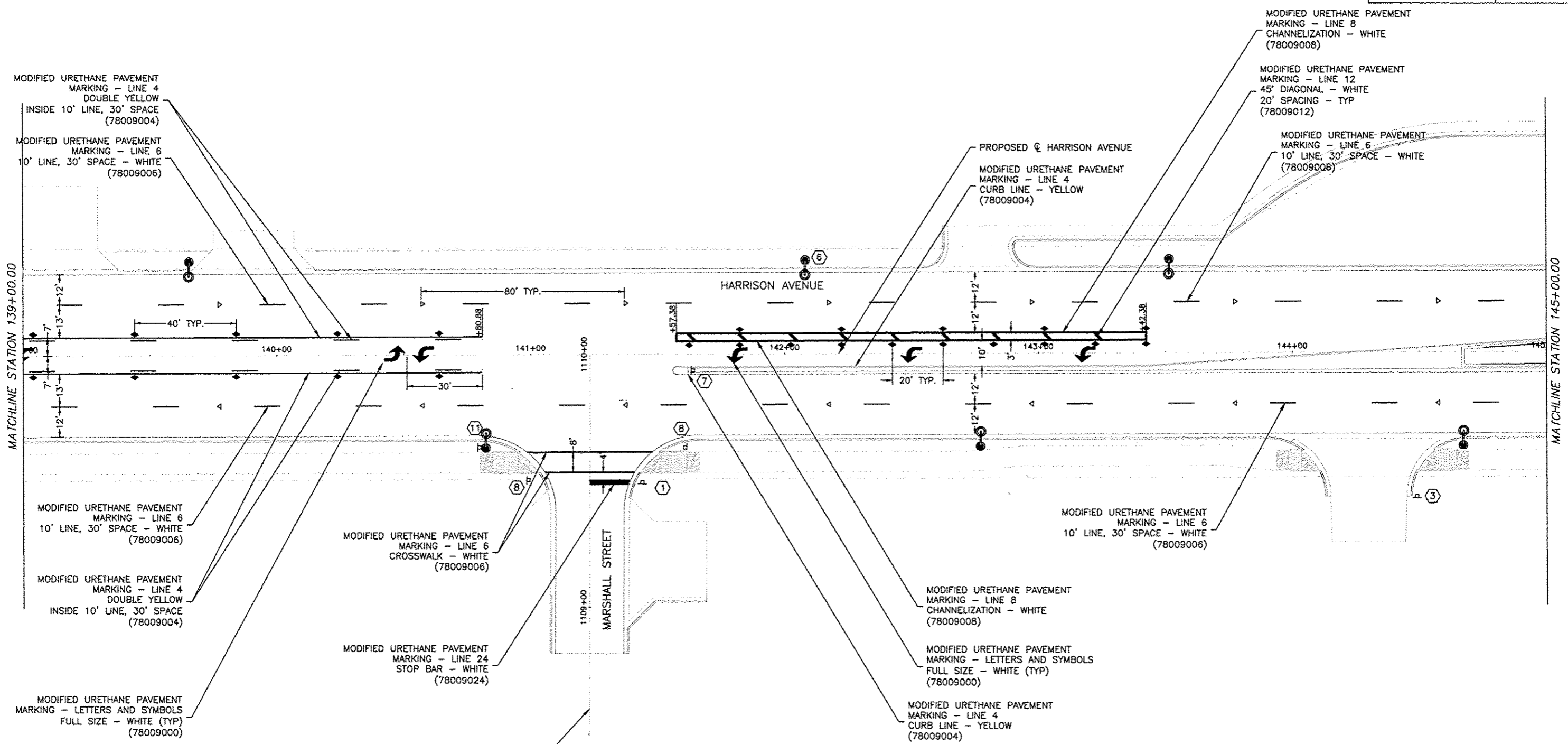

MODIFIED URETHANE PAVEMENT MARKING - LINE 4 DOUBLE YELLOW INSIDE 10' LINE, 30' SPACE (78009004)

MODIFIED URETHANE PAVEMENT MARKING - LINE 6 10' LINE, 30' SPACE - WHITE (78009006)

MODIFIED URETHANE PAVEMENT MARKING - LINE 8 CHANNELIZATION - WHITE (78009008)

MODIFIED URETHANE PAVEMENT MARKING - LINE 12 45' DIAGONAL - WHITE 20' SPACING - TYP (78009012)

MODIFIED URETHANE PAVEMENT MARKING - LINE 6 10' LINE, 30' SPACE - WHITE (78009006)

PROPOSED  $\phi$  HARRISON AVENUE

MODIFIED URETHANE PAVEMENT MARKING - LINE 4 CURB LINE - YELLOW (78009004)

MODIFIED URETHANE PAVEMENT MARKING - LINE 6 10' LINE, 30' SPACE - WHITE (78009006)

MODIFIED URETHANE PAVEMENT MARKING - LINE 4 DOUBLE YELLOW INSIDE 10' LINE, 30' SPACE (78009004)

MODIFIED URETHANE PAVEMENT MARKING - LINE 6 CROSSWALK - WHITE (78009006)

MODIFIED URETHANE PAVEMENT MARKING - LINE 6 10' LINE, 30' SPACE - WHITE (78009006)

MODIFIED URETHANE PAVEMENT MARKING - LINE 24 STOP BAR - WHITE (78009024)

MODIFIED URETHANE PAVEMENT MARKING - LINE 8 CHANNELIZATION - WHITE (78009008)

MODIFIED URETHANE PAVEMENT MARKING - LETTERS AND SYMBOLS FULL SIZE - WHITE (TYP) (78009000)

MODIFIED URETHANE PAVEMENT MARKING - LETTERS AND SYMBOLS FULL SIZE - WHITE (TYP) (78009000)

MODIFIED URETHANE PAVEMENT MARKING - LINE 4 CURB LINE - YELLOW (78009004)

PROPOSED  $\phi$  MARSHALL STREET

**SYMBOLS**

- ▶ ONE-WAY AMBER MARKER
- ▷ ONE-WAY CRYSTAL MARKER
- ◆ TWO-WAY AMBER MARKER
- # STREET SIGN DESIGNATOR (SEE DETAILS)

NOTE: ALL EXISTING PAVEMENT MARKINGS SHALL BE COMPLETELY REMOVED BEFORE APPLYING THE PROPOSED MODIFIED URETHANE PAVEMENT MARKINGS.

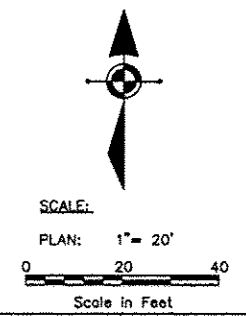

**FEHR GRAHAM**  
ENGINEERING & ENVIRONMENTAL  
ILLINOIS DESIGN FIRM NO. 184-003525  
© 2014 FEHR GRAHAM

ILLINOIS  
IOWA  
WISCONSIN

**McClure**  
Engineering Associates, Inc.  
7282 Argus Drive Rockford, Illinois 61107-5837  
(815) 398-2332 FAX (815) 398-2498  
Design Firm License: Illinois 184-000816  
Copyright 2014 By McClure Engineering Associates, Inc.

PROJECT AND LOCATION:  
HARRISON AVENUE RECONSTRUCTION  
IL 251 AND FAP 0525  
11TH ST. TO 20TH ST.

DRAWN BY: RCS  
APPROVED BY: JWH  
DATE: 6/12/2015  
SCALE:

| REVISIONS |             |      |
|-----------|-------------|------|
| REV. NO.  | DESCRIPTION | DATE |
|           |             |      |
|           |             |      |
|           |             |      |

DRAWING:  
PAVEMENT MARKING AND SIGNS

JOB NUMBER:  
13-1070  
SHEET NUMBER:  
316 of 588

ILL11-003 Section 0525(02501)CH0502(11-12) Pavement, Harrison Ave - 7



|             |                |                    |
|-------------|----------------|--------------------|
| F.A.P. RTE. | SECTION        | COUNTY             |
| 525         | 01-00509-00-RP | WINNEBAGO          |
| ILLINOIS    |                | CONTRACT NO. 85612 |

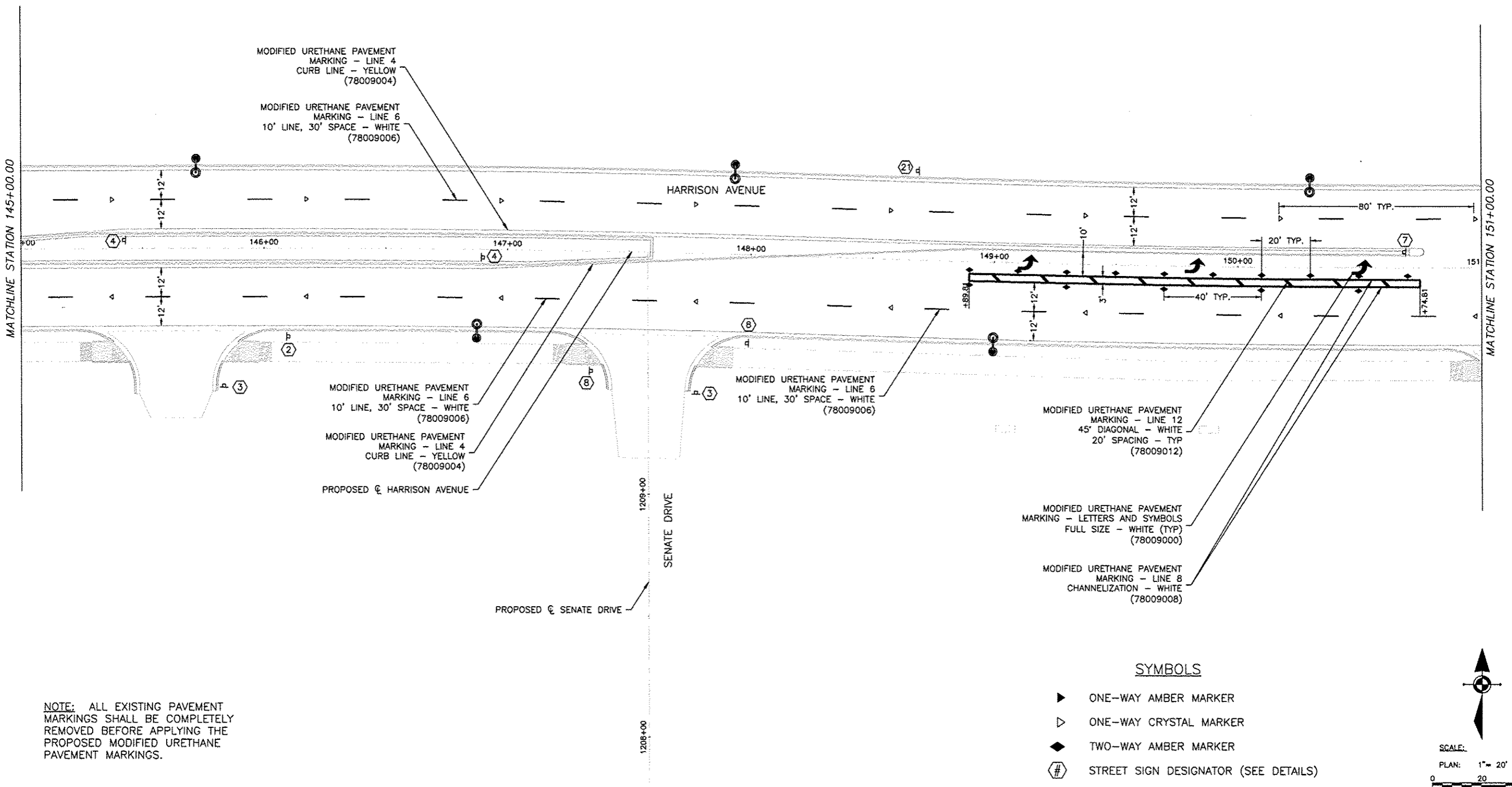

NOTE: ALL EXISTING PAVEMENT MARKINGS SHALL BE COMPLETELY REMOVED BEFORE APPLYING THE PROPOSED MODIFIED URETHANE PAVEMENT MARKINGS.

- SYMBOLS**
- ▶ ONE-WAY AMBER MARKER
  - ▷ ONE-WAY CRYSTAL MARKER
  - ◆ TWO-WAY AMBER MARKER
  - Ⓝ STREET SIGN DESIGNATOR (SEE DETAILS)

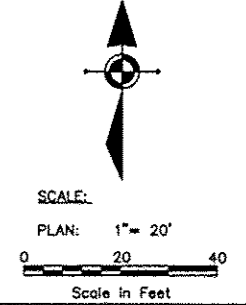

**FEHR GRAHAM**  
ENGINEERING & ENVIRONMENTAL  
ILLINOIS DESIGN FIRM NO. 184-003525  
© 2014 FEHR GRAHAM

ILLINOIS  
IOWA  
WISCONSIN

**McClure**  
Engineering Associates, Inc.  
7282 Argus Drive  
Rockford, Illinois 61107-5837  
Tel: (815) 398-2332 FAX: (815) 398-2498  
Design Firm License: Illinois 184-000618  
Copyright 2014 By McClure Engineering Associates, Inc.

PROJECT AND LOCATION:  
HARRISON AVENUE RECONSTRUCTION  
IL 251 AND FAP 0525  
11TH ST. TO 20TH ST.

DRAWN BY: RCS  
APPROVED BY: JWH  
DATE: 6/12/2015  
SCALE:

| REVISIONS |             |      |
|-----------|-------------|------|
| REV. NO.  | DESCRIPTION | DATE |
|           |             |      |
|           |             |      |
|           |             |      |

DRAWING:  
PAVEMENT MARKING AND SIGNS

JOB NUMBER:  
13-1070  
SHEET NUMBER:  
317 of 588

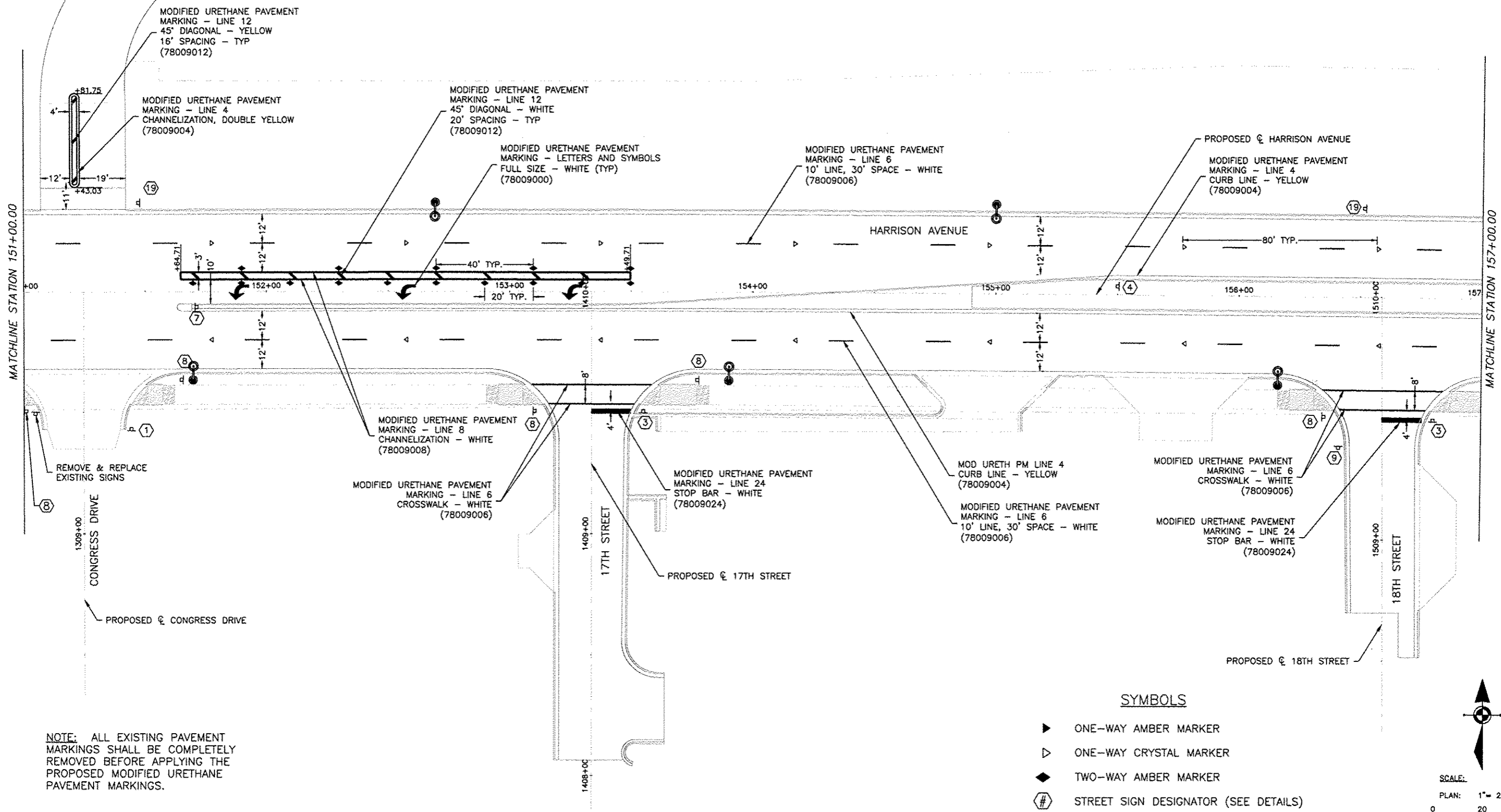

NOTE: ALL EXISTING PAVEMENT MARKINGS SHALL BE COMPLETELY REMOVED BEFORE APPLYING THE PROPOSED MODIFIED URETHANE PAVEMENT MARKINGS.

| REVISIONS |             |      |
|-----------|-------------|------|
| REV. NO.  | DESCRIPTION | DATE |
|           |             |      |
|           |             |      |
|           |             |      |

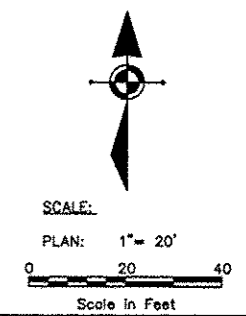

|             |                |                    |
|-------------|----------------|--------------------|
| F.A.P. RTE. | SECTION        | COUNTY             |
| 525         | 01-00509-00-RP | WINNEBAGO          |
| ILLINOIS    |                | CONTRACT NO. 85612 |

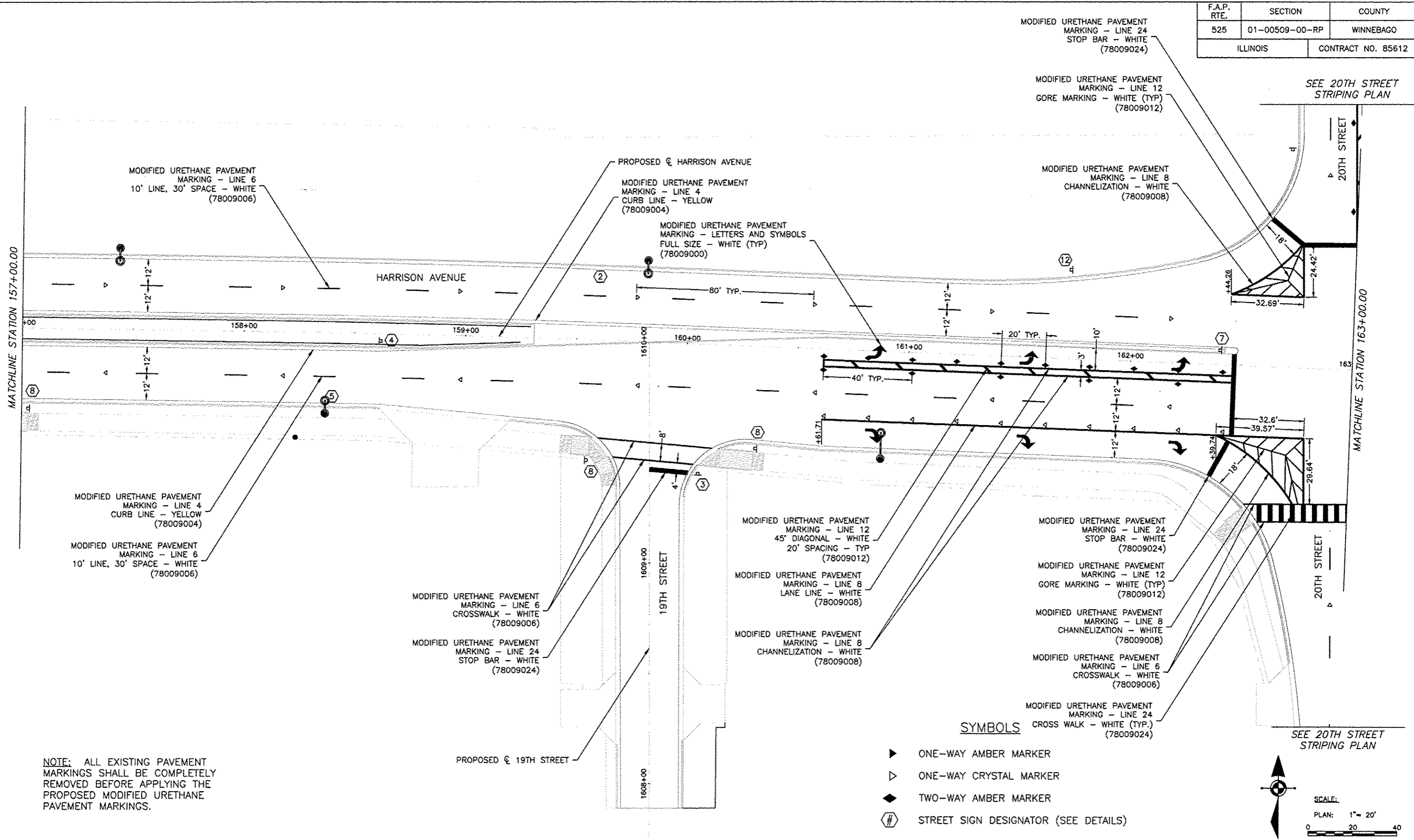

NOTE: ALL EXISTING PAVEMENT MARKINGS SHALL BE COMPLETELY REMOVED BEFORE APPLYING THE PROPOSED MODIFIED URETHANE PAVEMENT MARKINGS.

**SYMBOLS**

- ▶ ONE-WAY AMBER MARKER
- ▷ ONE-WAY CRYSTAL MARKER
- ◆ TWO-WAY AMBER MARKER
- ⊕ STREET SIGN DESIGNATOR (SEE DETAILS)



SCALE:  
 PLAN: 1" = 20'  
 0 20 40  
 Scale in Feet

**FEHR GRAHAM**  
 ENGINEERING & ENVIRONMENTAL  
 ILLINOIS DESIGN FIRM NO. 184-003525  
 © 2014 FEHR GRAHAM

ILLINOIS  
 IOWA  
 WISCONSIN

**McClure**  
 Engineering Associates, Inc.  
 7282 Argus Drive Rockford, Illinois 61107-5637  
 (815) 398-2332 FAX (815) 398-2486  
 Design Firm License: Illinois 184-000816  
 Copyright 2014 By McClure Engineering Associates, Inc.

PROJECT AND LOCATION:  
 HARRISON AVENUE RECONSTRUCTION  
 IL 251 AND FAP 0525  
 11TH ST. TO 20TH ST.

DRAWN BY: RCS  
 APPROVED BY: JWH  
 DATE: 6/12/2015  
 SCALE:

| REVISIONS |             |      |
|-----------|-------------|------|
| REV. NO.  | DESCRIPTION | DATE |
|           |             |      |
|           |             |      |
|           |             |      |

DRAWING:  
 PAVEMENT MARKING AND SIGNS

JOB NUMBER:  
 13-1070  
 SHEET NUMBER:  
 319 of 588

|             |                |                    |
|-------------|----------------|--------------------|
| F.A.P. RTE. | SECTION        | COUNTY             |
| 525         | 01-00509-00-RP | WINNEBAGO          |
| ILLINOIS    |                | CONTRACT NO. 85612 |

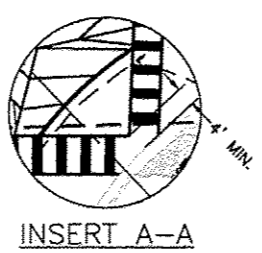
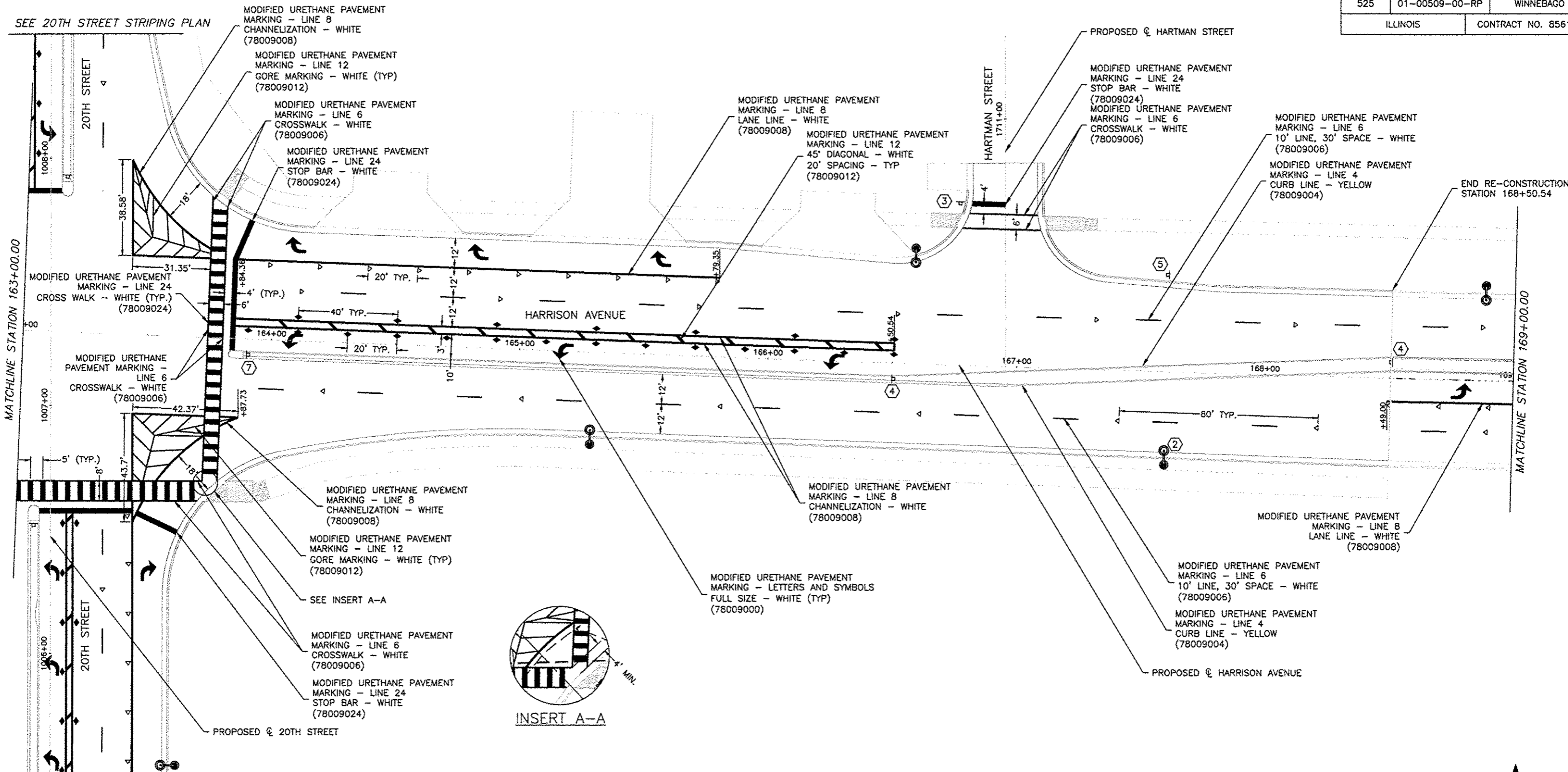

**SYMBOLS**

- ▶ ONE-WAY AMBER MARKER
- ▷ ONE-WAY CRYSTAL MARKER
- ◆ TWO-WAY AMBER MARKER
- Ⓝ STREET SIGN DESIGNATOR (SEE DETAILS)

**NOTE:** ALL EXISTING PAVEMENT MARKINGS SHALL BE COMPLETELY REMOVED BEFORE APPLYING THE PROPOSED MODIFIED URETHANE PAVEMENT MARKINGS.

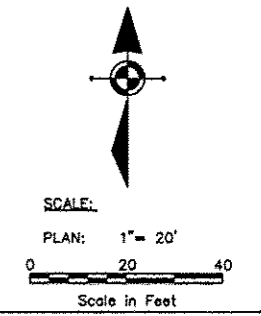

**FEHR GRAHAM**  
ENGINEERING & ENVIRONMENTAL  
ILLINOIS DESIGN FIRM NO. 184-003525  
© 2014 FEHR GRAHAM

ILLINOIS  
IOWA  
WISCONSIN

**McClure**  
Engineering Associates, Inc.  
7262 Argus Drive Rockford, Illinois 61107-6837  
(815) 398-2332 FAX (815) 398-2498  
Design Firm License: Illinois 184-000816  
Copyright 2014 By McClure Engineering Associates, Inc.

PROJECT AND LOCATION:  
HARRISON AVENUE RECONSTRUCTION  
IL 251 AND FAP 0525  
11TH ST. TO 20TH ST.

DRAWN BY: RCS  
APPROVED BY: JWH  
DATE: 6/12/2015  
SCALE:

| REVISIONS |             |      |
|-----------|-------------|------|
| REV. NO.  | DESCRIPTION | DATE |
|           |             |      |
|           |             |      |
|           |             |      |

DRAWING:  
PAVEMENT MARKING AND SIGNS  
W:\11-002\harrison\design\CD\04\PAVEMENT\11-128\Stripping.dwg, Harrison Ave - 11

JOB NUMBER:  
13-1070  
SHEET NUMBER:  
320 of 588

|             |                |                    |
|-------------|----------------|--------------------|
| F.A.P. RTE. | SECTION        | COUNTY             |
| 525         | 01-00509-00-RP | WINNEBAGO          |
| ILLINOIS    |                | CONTRACT NO. 85612 |

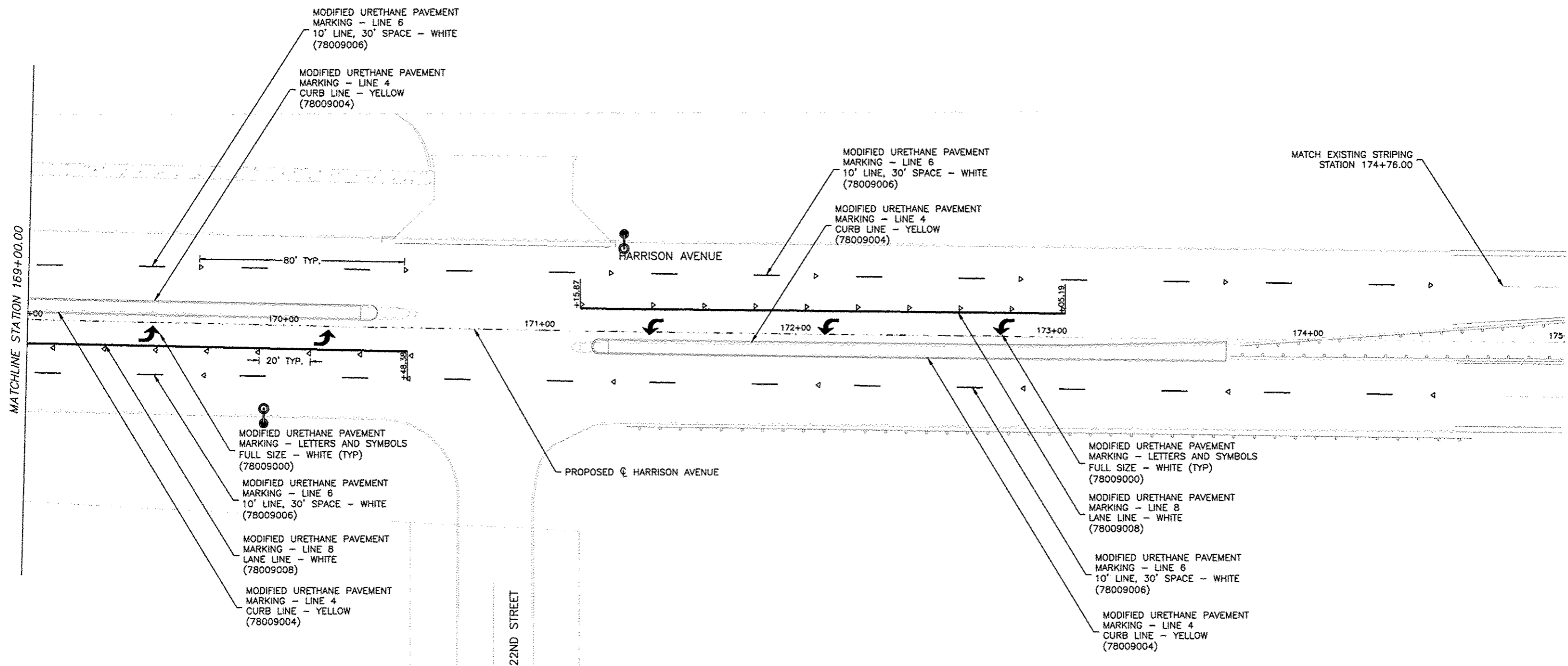

NOTE: ALL EXISTING PAVEMENT MARKINGS SHALL BE COMPLETELY REMOVED BEFORE APPLYING THE PROPOSED MODIFIED URETHANE PAVEMENT MARKINGS.

- SYMBOLS**
- ▶ ONE-WAY AMBER MARKER
  - ▷ ONE-WAY CRYSTAL MARKER
  - ◆ TWO-WAY AMBER MARKER
  - Ⓝ STREET SIGN DESIGNATOR (SEE DETAILS)

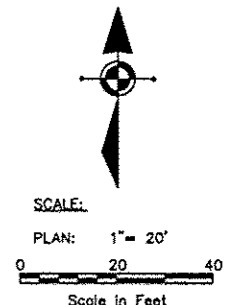

**FEHR GRAHAM**  
ENGINEERING & ENVIRONMENTAL  
ILLINOIS DESIGN FIRM NO. 184-003525  
© 2014 FEHR GRAHAM

ILLINOIS  
IOWA  
WISCONSIN

**McClure**  
Engineering Associates, Inc.  
7282 Argus Drive Rockford, Illinois 61107-5837  
(815) 398-2332 FAX (815) 398-2496  
Design Firm License: Illinois 184-000618  
Copyright 2014 By McClure Engineering Associates, Inc.

PROJECT AND LOCATION:  
HARRISON AVENUE RECONSTRUCTION  
IL 251 AND FAP 0525  
11TH ST. TO 20TH ST.

DRAWN BY: RCS  
APPROVED BY: JWH  
DATE: 6/12/2015  
SCALE:

| REVISIONS |             |      |
|-----------|-------------|------|
| REV. NO.  | DESCRIPTION | DATE |
|           |             |      |
|           |             |      |
|           |             |      |

DRAWING:  
PAVEMENT MARKING AND SIGNS

JOB NUMBER:  
13-1070  
SHEET NUMBER:  
321 of 588

|             |                |                    |
|-------------|----------------|--------------------|
| F.A.P. RTE. | SECTION        | COUNTY             |
| 525         | 01-00509-00-RP | WINNEBAGO          |
| ILLINOIS    |                | CONTRACT NO. 85612 |

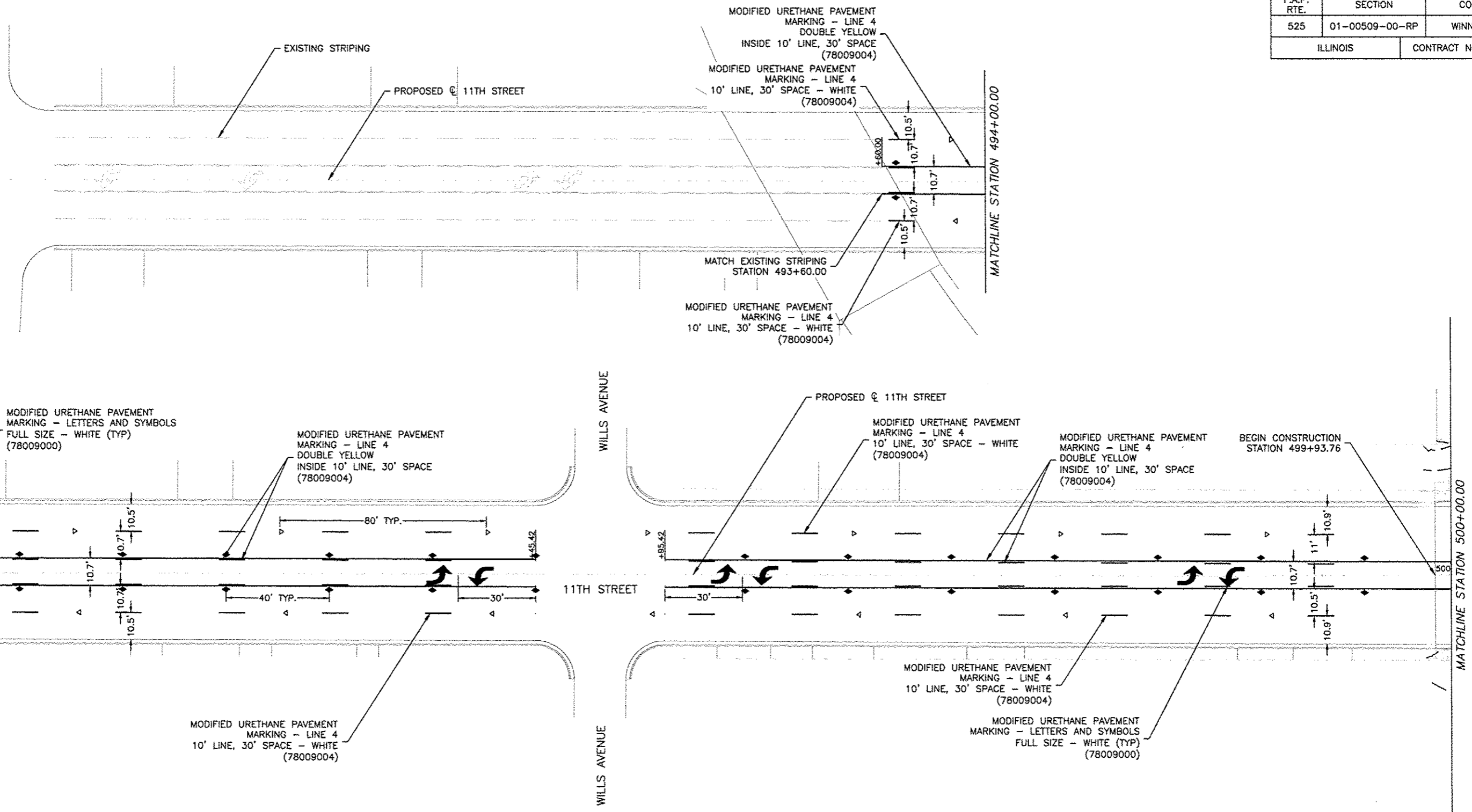

NOTE: ALL EXISTING PAVEMENT MARKINGS SHALL BE COMPLETELY REMOVED BEFORE APPLYING THE PROPOSED MODIFIED URETHANE PAVEMENT MARKINGS.

**SYMBOLS**

- ▶ ONE-WAY AMBER MARKER
- ▷ ONE-WAY CRYSTAL MARKER
- ◆ TWO-WAY AMBER MARKER
- ⊕ STREET SIGN DESIGNATOR (SEE DETAILS)

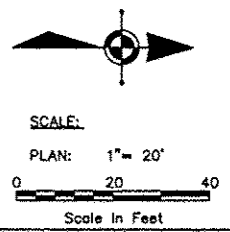

**FEHR GRAHAM**  
ENGINEERING & ENVIRONMENTAL  
ILLINOIS DESIGN FIRM NO. 184-003525  
© 2014 FEHR GRAHAM

ILLINOIS  
IOWA  
WISCONSIN

**McClure**  
Engineering Associates, Inc.  
7282 Argus Drive Rockford, Illinois 61107-6837  
(815) 398-2332 FAX (815) 398-2498  
Design Firm License: Illinois 184-000616  
Copyright 2014 By McClure Engineering Associates, Inc.

PROJECT AND LOCATION:  
HARRISON AVENUE RECONSTRUCTION  
IL 251 AND FAP 0525  
11TH ST. TO 20TH ST.

DRAWN BY: RCS  
APPROVED BY: JWH  
DATE: 6/12/2015  
SCALE:

| REVISIONS |             |      |
|-----------|-------------|------|
| REV. NO.  | DESCRIPTION | DATE |
|           |             |      |
|           |             |      |
|           |             |      |

DRAWING:  
PAVEMENT MARKING AND SIGNS

JOB NUMBER:  
13-1070

SHEET NUMBER:  
322 of 588

11/11-003 harriso.dwg/2015/06/12/2015/11-138 8/12/2015, 11:28 Sheet - 1

|             |                |                    |
|-------------|----------------|--------------------|
| F.A.P. RTE. | SECTION        | COUNTY             |
| 525         | 01-00509-00-RP | WINNEBAGO          |
| ILLINOIS    |                | CONTRACT NO. 85612 |

MATCHLINE STATION 500+00.00

MATCHLINE STATION 506+00.00

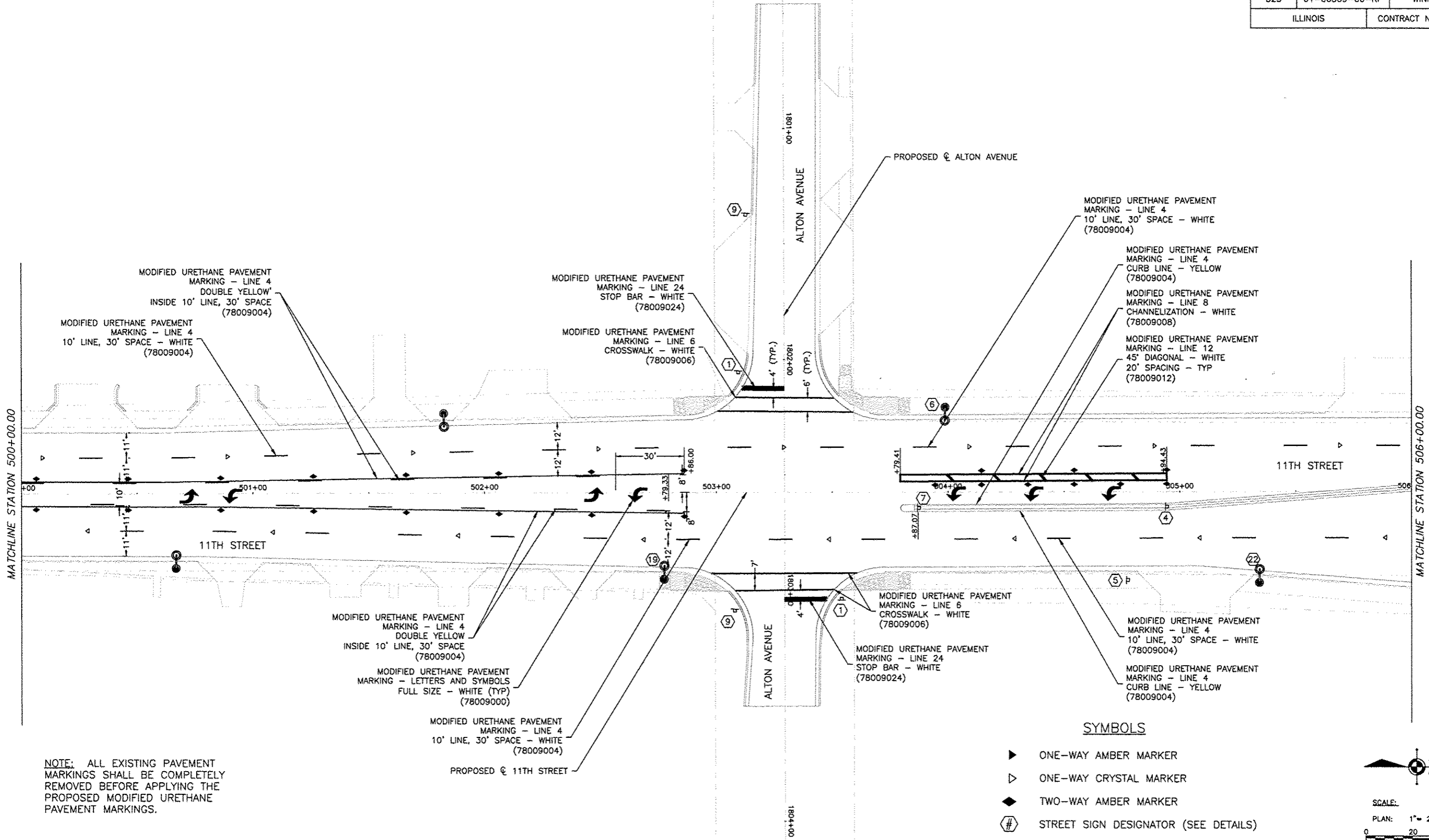

NOTE: ALL EXISTING PAVEMENT MARKINGS SHALL BE COMPLETELY REMOVED BEFORE APPLYING THE PROPOSED MODIFIED URETHANE PAVEMENT MARKINGS.

**SYMBOLS**

- ▶ ONE-WAY AMBER MARKER
- ▷ ONE-WAY CRYSTAL MARKER
- ◆ TWO-WAY AMBER MARKER
- Ⓜ STREET SIGN DESIGNATOR (SEE DETAILS)



SCALE:  
PLAN: 1" = 20'  
0 20 40  
Scale in Feet

| REVISIONS |             |      |
|-----------|-------------|------|
| REV. NO.  | DESCRIPTION | DATE |
|           |             |      |
|           |             |      |
|           |             |      |

|  |
|--|
| DRAWING:<br>PAVEMENT MARKING AND SIGNS |
|--|

|             |                |                    |
|-------------|----------------|--------------------|
| F.A.P. RTE. | SECTION        | COUNTY             |
| 525         | 01-00509-00-RP | WINNEBAGO          |
| ILLINOIS    |                | CONTRACT NO. 85612 |

SEE HARRISON AVENUE STRIPING PLAN

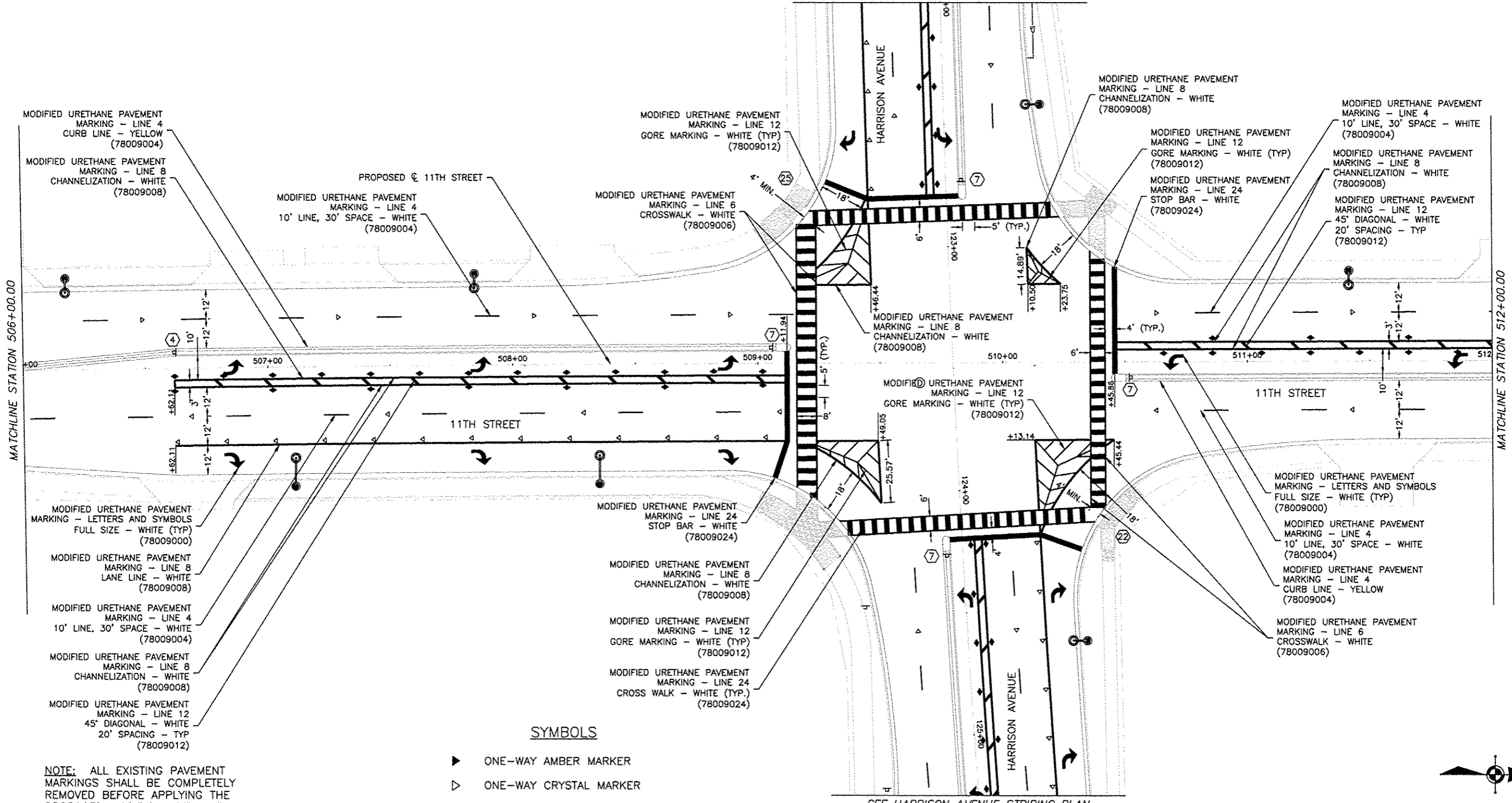

- MODIFIED URETHANE PAVEMENT MARKING - LINE 4 CURB LINE - YELLOW (78009004)
- MODIFIED URETHANE PAVEMENT MARKING - LINE 8 CHANNELIZATION - WHITE (78009008)
- MODIFIED URETHANE PAVEMENT MARKING - LINE 4 10' LINE, 30' SPACE - WHITE (78009004)
- MODIFIED URETHANE PAVEMENT MARKING - LINE 6 CROSSWALK - WHITE (78009006)
- MODIFIED URETHANE PAVEMENT MARKING - LINE 12 GORE MARKING - WHITE (TYP) (78009012)
- MODIFIED URETHANE PAVEMENT MARKING - LINE 8 CHANNELIZATION - WHITE (78009008)
- MODIFIED URETHANE PAVEMENT MARKING - LINE 12 GORE MARKING - WHITE (TYP) (78009012)
- MODIFIED URETHANE PAVEMENT MARKING - LINE 24 STOP BAR - WHITE (78009024)
- MODIFIED URETHANE PAVEMENT MARKING - LINE 4 10' LINE, 30' SPACE - WHITE (78009004)
- MODIFIED URETHANE PAVEMENT MARKING - LINE 8 CHANNELIZATION - WHITE (78009008)
- MODIFIED URETHANE PAVEMENT MARKING - LINE 4 LANE LINE - WHITE (78009008)
- MODIFIED URETHANE PAVEMENT MARKING - LINE 4 10' LINE, 30' SPACE - WHITE (78009004)
- MODIFIED URETHANE PAVEMENT MARKING - LINE 8 CHANNELIZATION - WHITE (78009008)
- MODIFIED URETHANE PAVEMENT MARKING - LINE 12 45° DIAGONAL - WHITE 20' SPACING - TYP (78009012)
- MODIFIED URETHANE PAVEMENT MARKING - LINE 12 GORE MARKING - WHITE (TYP) (78009012)
- MODIFIED URETHANE PAVEMENT MARKING - LINE 24 STOP BAR - WHITE (78009024)
- MODIFIED URETHANE PAVEMENT MARKING - LINE 8 CHANNELIZATION - WHITE (78009008)
- MODIFIED URETHANE PAVEMENT MARKING - LINE 12 GORE MARKING - WHITE (TYP) (78009012)
- MODIFIED URETHANE PAVEMENT MARKING - LINE 24 CROSS WALK - WHITE (TYP) (78009024)

PROPOSED  $\phi$  11TH STREET  
 MODIFIED URETHANE PAVEMENT MARKING - LINE 4 10' LINE, 30' SPACE - WHITE (78009004)

**SYMBOLS**

- ▶ ONE-WAY AMBER MARKER
- ▷ ONE-WAY CRYSTAL MARKER
- ◆ TWO-WAY AMBER MARKER
- # STREET SIGN DESIGNATOR (SEE DETAILS)

NOTE: ALL EXISTING PAVEMENT MARKINGS SHALL BE COMPLETELY REMOVED BEFORE APPLYING THE PROPOSED MODIFIED URETHANE PAVEMENT MARKINGS.

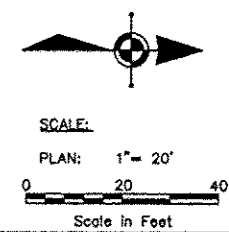

**FEHR GRAHAM**  
 ENGINEERING & ENVIRONMENTAL  
 ILLINOIS DESIGN FIRM NO. 184-003525  
 © 2014 FEHR GRAHAM

ILLINOIS  
 IOWA  
 WISCONSIN

**McClure**  
 Engineering Associates, Inc.  
 7282 Argus Drive  
 (815) 398-2332  
 Design Firm License: Illinois 184-000818  
 Copyright 2014 By McClure Engineering Associates, Inc.

Rockford, Illinois 61107-5837  
 FAX (815) 398-2498

PROJECT AND LOCATION:  
 HARRISON AVENUE RECONSTRUCTION  
 IL 251 AND FAP 0525  
 11TH ST. TO 20TH ST.

DRAWN BY: RCS  
 APPROVED BY: JWH  
 DATE: 6/12/2015  
 SCALE:

| REVISIONS |             |      |
|-----------|-------------|------|
| REV. NO.  | DESCRIPTION | DATE |
|           |             |      |
|           |             |      |
|           |             |      |

DRAWING:  
 PAVEMENT MARKING AND SIGNS

JOB NUMBER:  
 13-1070

SHEET NUMBER:  
 324 of 588



|             |                |                    |
|-------------|----------------|--------------------|
| F.A.P. RTE. | SECTION        | COUNTY             |
| 525         | 01-00509-00-RP | WINNEBAGO          |
| ILLINOIS    |                | CONTRACT NO. 85612 |

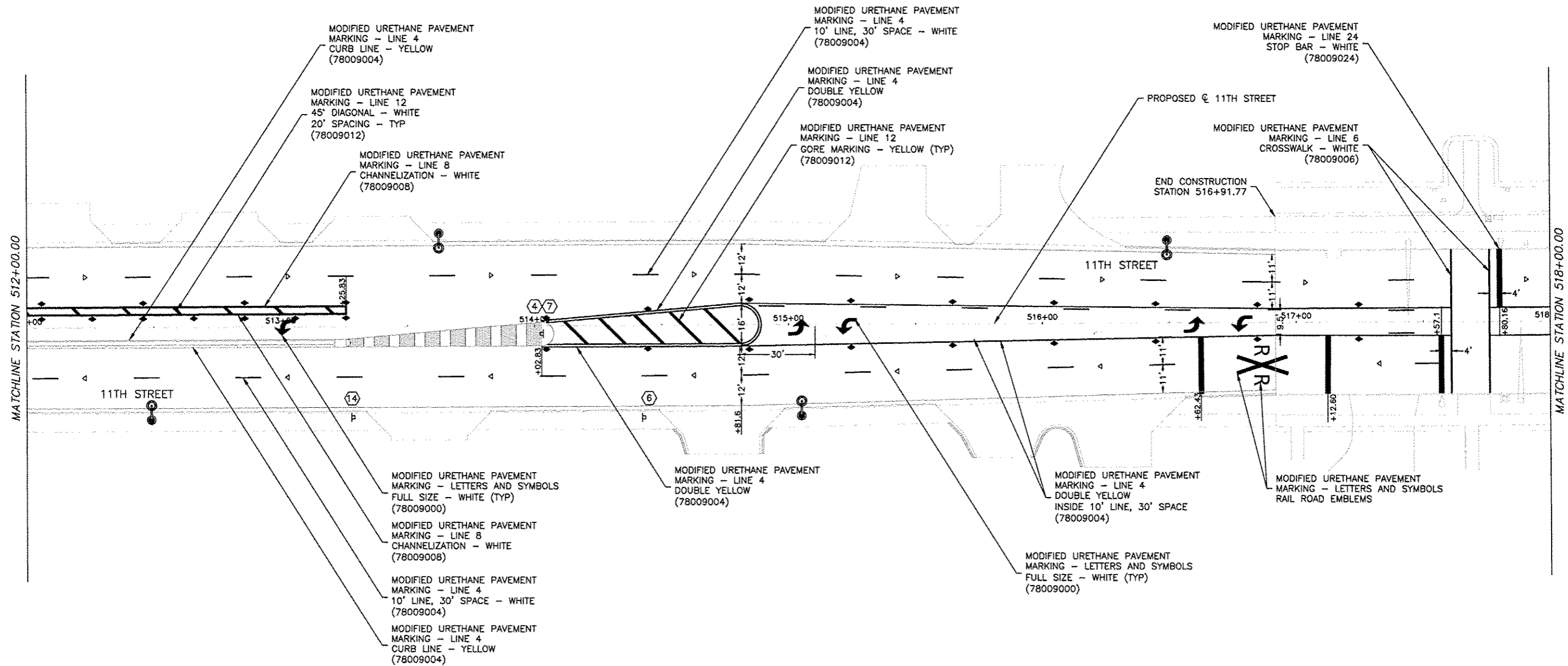

**SYMBOLS**

- ▶ ONE-WAY AMBER MARKER
- ▷ ONE-WAY CRYSTAL MARKER
- ◆ TWO-WAY AMBER MARKER
- Ⓜ STREET SIGN DESIGNATOR (SEE DETAILS)

NOTE: ALL EXISTING PAVEMENT MARKINGS SHALL BE COMPLETELY REMOVED BEFORE APPLYING THE PROPOSED MODIFIED URETHANE PAVEMENT MARKINGS.

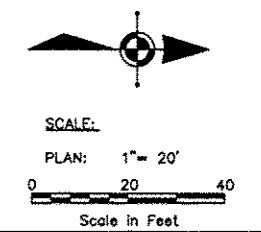

**FEHR GRAHAM**  
ENGINEERING & ENVIRONMENTAL  
ILLINOIS DESIGN FIRM NO. 184-003525  
© 2014 FEHR GRAHAM

ILLINOIS  
IOWA  
WISCONSIN

**McClure**  
Engineering Associates, Inc.  
7282 Argus Drive Rockford, Illinois 61107-6637  
16161 398-2332 FAX (815) 398-2496  
Design Firm License: Illinois 184-000816  
Copyright 2014 By McClure Engineering Associates, Inc.

PROJECT AND LOCATION:  
HARRISON AVENUE RECONSTRUCTION  
IL 251 AND FAP 0525  
11TH ST. TO 20TH ST.

DRAWN BY: RCS  
APPROVED BY: JWH  
DATE: 6/12/2015  
SCALE:

| REVISIONS |             |      |
|-----------|-------------|------|
| REV. NO.  | DESCRIPTION | DATE |
|           |             |      |
|           |             |      |
|           |             |      |

DRAWING:  
PAVEMENT MARKING AND SIGNS

JOB NUMBER:  
13-1070

SHEET NUMBER:  
325 of 588

|             |                |                    |
|-------------|----------------|--------------------|
| F.A.P. RTE. | SECTION        | COUNTY             |
| 525         | 01-00509-00-RP | WINNEBAGO          |
| ILLINOIS    |                | CONTRACT NO. 85612 |

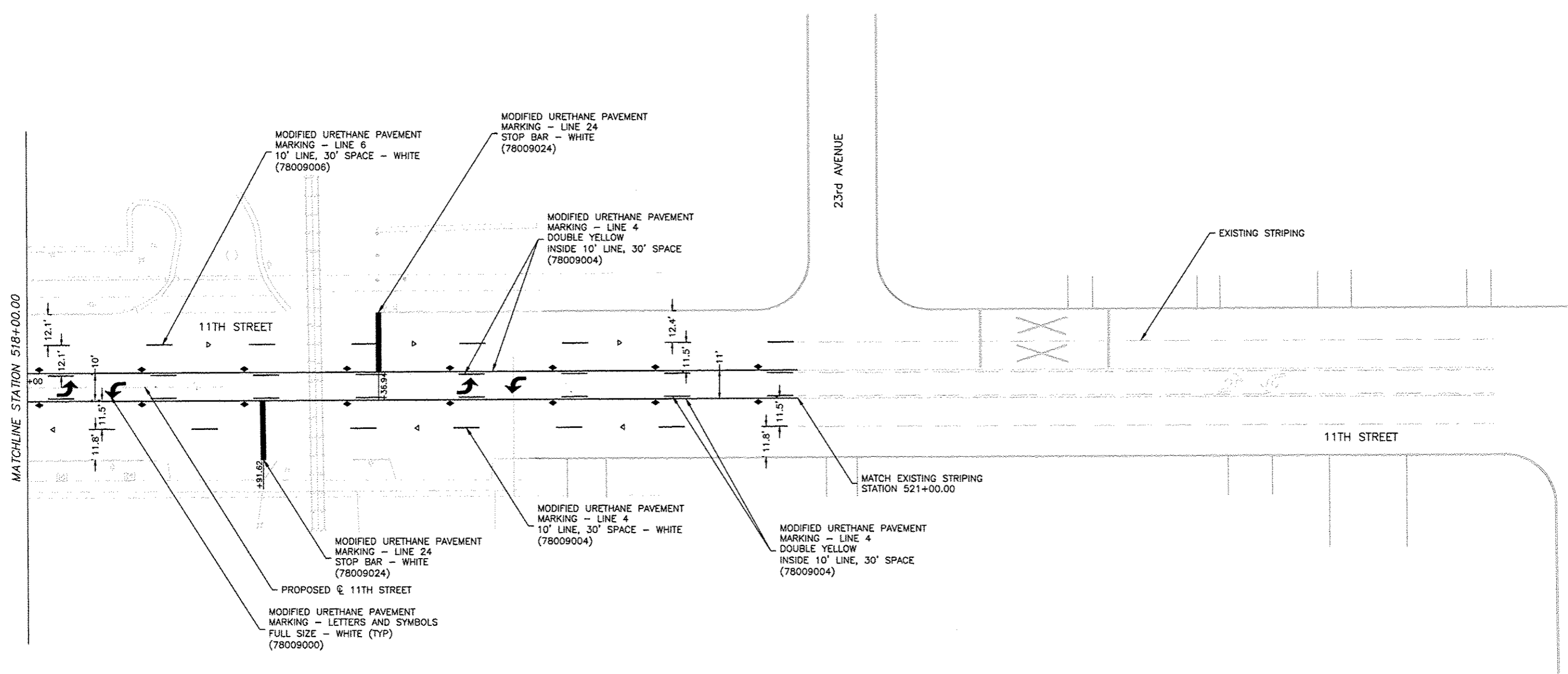

MATCHLINE STATION 518+00.00

NOTE: ALL EXISTING PAVEMENT MARKINGS SHALL BE COMPLETELY REMOVED BEFORE APPLYING THE PROPOSED MODIFIED URETHANE PAVEMENT MARKINGS.

**SYMBOLS**

- ▶ ONE-WAY AMBER MARKER
- ▷ ONE-WAY CRYSTAL MARKER
- ◆ TWO-WAY AMBER MARKER
- Ⓜ STREET SIGN DESIGNATOR (SEE DETAILS)

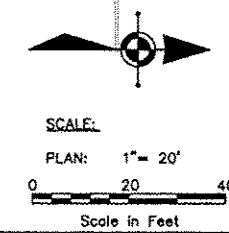

**FEHR GRAHAM**  
ENGINEERING & ENVIRONMENTAL  
ILLINOIS DESIGN FIRM NO. 184-003525  
© 2014 FEHR GRAHAM

ILLINOIS  
IOWA  
WISCONSIN

**McClure**  
Engineering Associates, Inc.  
7282 Argus Drive Rockford, Illinois 61107-5837  
(815) 398-2332 FAX (815) 398-2486  
Design Firm License: Illinois 184-000815  
Copyright 2014 By McClure Engineering Associates, Inc.

PROJECT AND LOCATION:  
HARRISON AVENUE RECONSTRUCTION  
IL 251 AND FAP 0525  
11TH ST. TO 20TH ST.

DRAWN BY: RCS  
APPROVED BY: JWH  
DATE: 6/12/2015  
SCALE:

| REVISIONS |             |      |
|-----------|-------------|------|
| REV. NO.  | DESCRIPTION | DATE |
|           |             |      |
|           |             |      |
|           |             |      |

DRAWING:  
PAVEMENT MARKING AND SIGNS

JOB NUMBER:  
13-1070  
SHEET NUMBER:  
326 of 588

|             |                |                    |
|-------------|----------------|--------------------|
| F.A.P. RTE. | SECTION        | COUNTY             |
| 525         | 01-00509-00-RP | WINNEBAGO          |
| ILLINOIS    |                | CONTRACT NO. 85612 |

SEE HARRISON AVENUE STRIPING PLANS

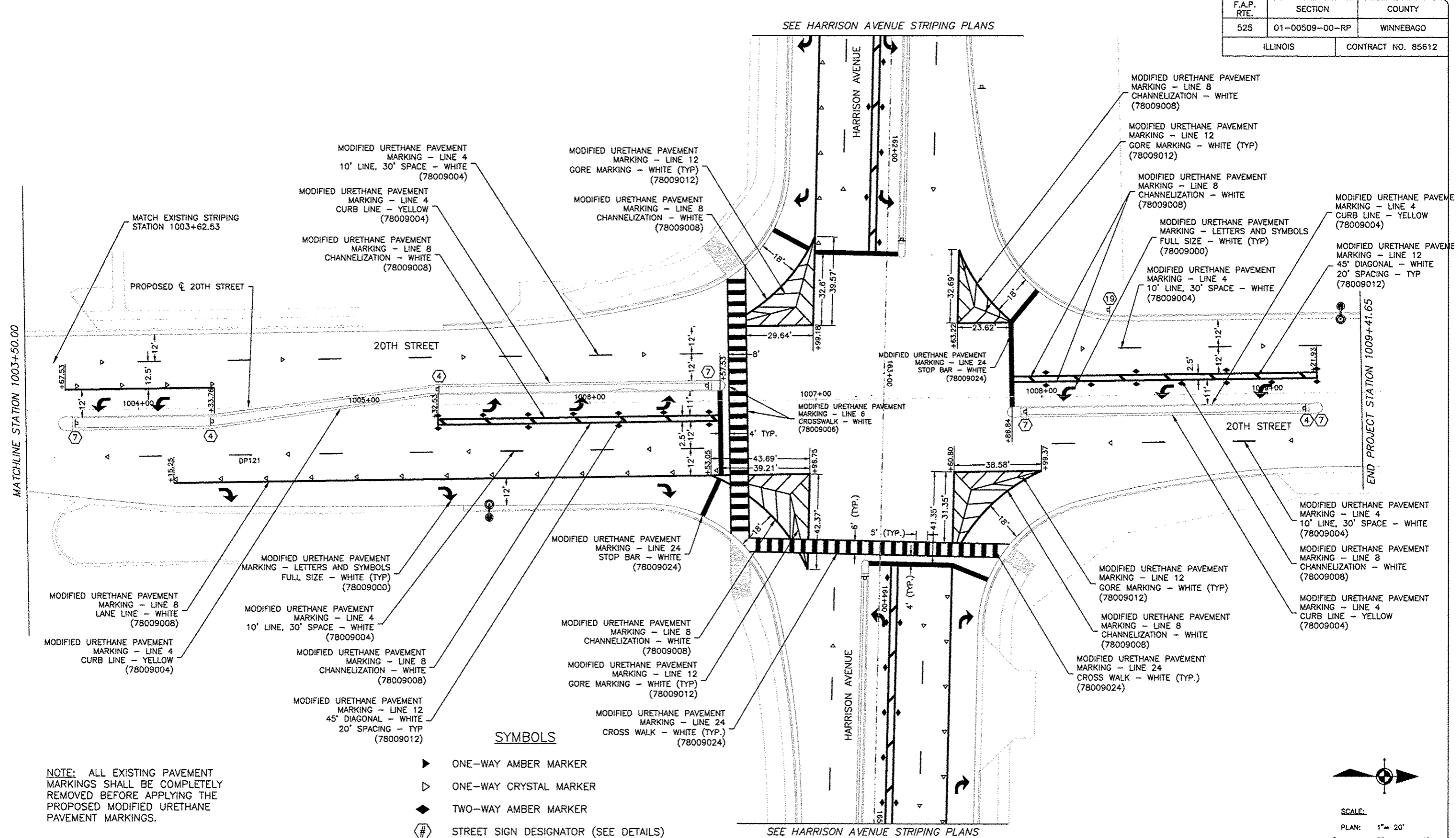

NOTE: ALL EXISTING PAVEMENT MARKINGS SHALL BE COMPLETELY REMOVED BEFORE APPLYING THE PROPOSED MODIFIED URETHANE PAVEMENT MARKINGS.

- SYMBOLS**
- ▶ ONE-WAY AMBER MARKER
  - ▷ ONE-WAY CRYSTAL MARKER
  - ◆ TWO-WAY AMBER MARKER
  - # STREET SIGN DESIGNATOR (SEE DETAILS)

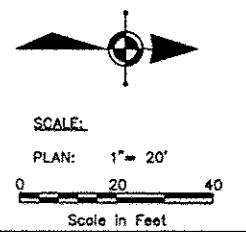

**FEHR GRAHAM**  
ENGINEERING & ENVIRONMENTAL  
ILLINOIS DESIGN FIRM NO. 184-003525

ILLINOIS  
IOWA  
WISCONSIN

© 2014 FEHR GRAHAM

**McClure**  
Engineering Associates, Inc.  
7282 Argus Drive  
Rockford, Illinois 61107-5537  
6151 398-2332 FAX (815) 398-2400  
Design Firm License: Illinois 184-000616  
Copyright 2014 By McClure Engineering Associates, Inc.

PROJECT AND LOCATION:  
HARRISON AVENUE RECONSTRUCTION  
IL 251 AND FAP 0525  
11TH ST. TO 20TH ST.

DRAWN BY: RCS  
APPROVED BY: JWH  
DATE: 6/12/2015  
SCALE:

| REVISIONS |             |      |
|-----------|-------------|------|
| REV. NO.  | DESCRIPTION | DATE |
|           |             |      |
|           |             |      |
|           |             |      |

DRAWING:  
PAVEMENT MARKING AND SIGNS

JOB NUMBER:  
13-1070

SHEET NUMBER:  
327 of 588

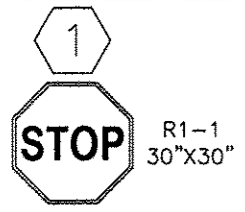

R1-1  
30"x30"

209+57.0, 21.0' RT  
609+47.1, 18.9' RT  
709+49.0, 20.3' RT  
809+49.6, 23.4' RT  
909+49.5, 20.6' RT  
1109+49.4, 20.6' RT  
1309+43.0, 19.6' RT  
1802+12.2, 24.5' RT  
1803+03.7, 24.6' LT

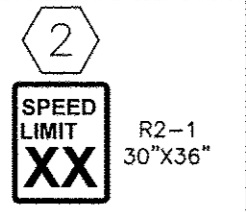

R2-1  
30"x36"

113+85.7, 32.2' LT 35 MPH  
135+65.3, 36.7' LT 40 MPH  
146+10.0, 36.6' RT 40 MPH  
159+81.0, 36.8' LT 40 MPH \*  
167+60.3, 37.5' RT 45 MPH \*  
309+07.1, 18.0' LT 30 MPH \*

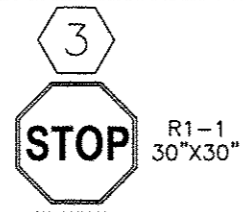

R1-1  
30"x30"

R3-2  
24"x24"

144+48.8, 57.0' RT  
145+83.4, 57.0' RT  
309+51.2, 20.2' RT  
409+30.7, 18.3' RT  
1209+41.8, 19.6' RT  
1409+50.4, 21.3' RT  
1509+49.2, 20.9' RT  
1609+40.3, 21.8' RT  
1710+66.2, 18.1' LT

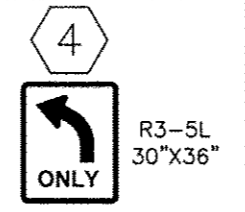

R3-5L  
30"x36"

118+94.4, 2.9' RT  
129+30.6, 0.4' LT  
145+42.4, 3.4' LT  
146+89.8, 3.4' RT  
155+50.0, 3.4' LT  
158+61.7, 3.4' RT  
166+50.5, 6.5' RT  
168+50.5, 6.4' LT  
504+94.5, 6.5' RT  
506+62.0, 6.5' LT  
514+02.8, 3.3' RT  
1004+32.5, 6.0' LT  
1005+32.5, 6.8' LT  
1009+16.2, 6.8' RT

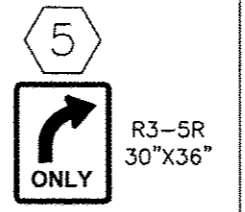

R3-5R  
30"x36"

118+29.8, 37.1' RT  
128+05.0, 43.6' LT  
158+37.0, 36.7' LT \*  
167+60.1, 39.3' LT  
505+06.9, 37.1' RT

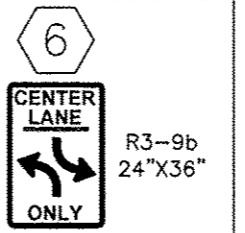

R3-9b  
24"x36"

129+71.5, 37.0' RT \*  
142+08.2, 36.7' LT \*  
503+98.8, 36.8' LT \*  
514+43.0, 36.6' RT

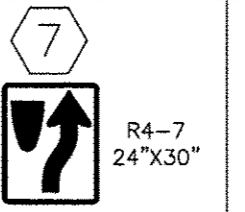

R4-7  
24"x30"

116+59.9, 2.9' LT  
122+73.0, 6.3' LT  
124+26.3, 6.5' RT  
127+18.2, 6.5' RT  
129+85.7, 3.5' RT  
141+23.6, 44.5' LT  
141+23.6, 62.5' LT  
141+63.9, 6.5' RT  
150+68.3, 6.5' LT  
151+71.2, 6.5' RT  
162+40.2, 6.5' LT  
163+90.9, 6.5' RT  
503+87.4, 7.0' RT  
509+05.5, 6.5' LT  
510+52.3, 6.5' RT  
514+02.8, 3.3' RT  
1003+72.5, 6.0' RT  
1006+51.8, 6.8' LT  
1007+92.6, 6.8' RT  
1009+16.2, 6.8' RT

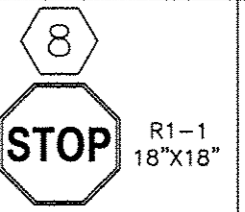

R1-1  
18"x18"

114+05.3, 29.1' RT  
117+36.8, 34.0' RT  
120+65.1, 49.1' RT  
127+22.2, 36.6' RT  
130+50.0, 37.2' RT  
133+81.8, 36.9' RT  
138+64.0, 36.6' RT  
141+60.7, 36.9' RT  
147+99.3, 36.6' RT  
151+65.0, 36.6' RT  
153+77.3, 36.6' RT  
157+03.0, 36.6' RT  
160+32.4, 46.4' RT

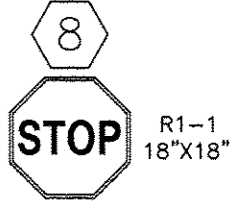

R1-1  
18"x18"

209+58.8, 33.7' LT  
309+58.6, 22.9' LT  
409+38.3, 29.2' LT  
609+41.1, 29.1' LT  
709+50.6, 33.5' LT  
809+49.5, 20.9' LT  
909+50.3, 24.2' LT  
1109+50.3, 24.2' LT  
1209+50.9, 23.5' LT  
1309+50.6, 23.7' LT  
1409+50.5, 23.4' LT  
1509+50.7, 24.0' LT  
1609+46.4, 28.7' LT

\* MOUNT ON LIGHT POLE

\* MOUNT ON LIGHT POLE

\* MOUNT ON LIGHT POLE

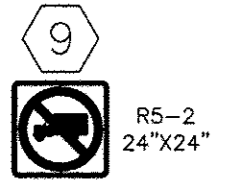

R5-2  
24"x24"

409+31.5, 18.0' LT  
608+35.0, 21.3' LT \*  
809+27.0, 18.9' LT  
1509+37.9, 18.0' LT  
1801+44.5, 16.6' RT  
1803+09.1, 22.0' RT

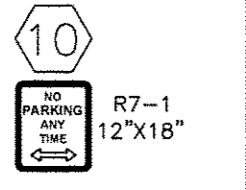

R7-1  
12"x18"

709+10.0, 18.0' RT

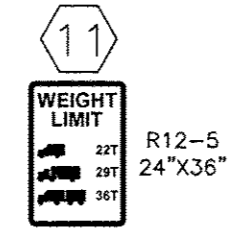

R12-5  
24"x36"

140+79.7, 36.6' RT  
(TO BE MAINTAINED UNTIL NEW BOX CULVERT AT 143+74 IS PUT INTO SERVICE)

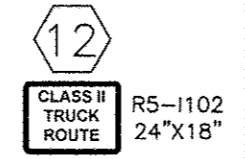

R5-1102  
24"x18"

161+71.8, 40.3' LT \*

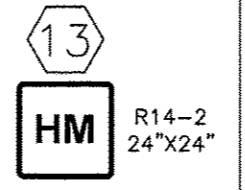

R14-2  
24"x24"

124+45.4, 41.0' RT



W11-2  
36"x36"

513+28.6, 36.0' RT

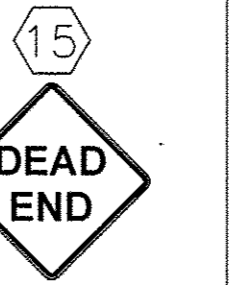

W14-1  
36"x36"

909+16.1, 18.1' LT

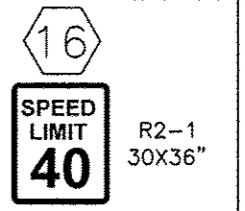

R2-1  
30X36"

R3-5R  
30"x36"

125+20.0, 37.1' RT

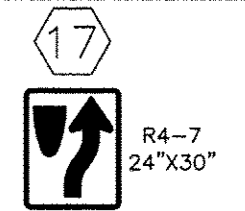

R4-7  
24"x30"

R3-5L  
30"x36"

126+55.3, 6.1' RT

\* ON EXISTING POWER POLE

\* ON EXISTING POWER POLE

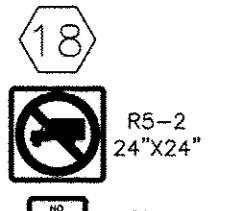

R5-2  
24"x24"

R7-1  
12"x18"

709+10.0, 18.1' LT

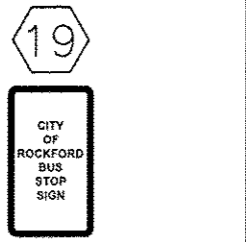

138+18.5, 36.6' RT  
148+67.4, 36.6' LT  
151+47.3, 36.6' LT  
156+51.4, 36.6' LT  
502+77.3, 37.6, RT \*  
1008+30.0, 38.1' LT

\* MOUNT ON LIGHT POLE FURNISHED BY THE CITY OF ROCKFORD RMTD, INSTALLED BY THE CONTRACTOR

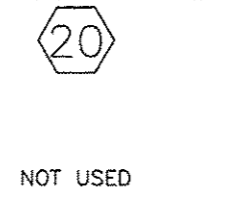

NOT USED

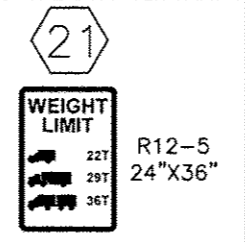

R12-5  
24"x36"

148+67.4, 36.6' LT  
(TO BE MAINTAINED UNTIL NEW BOX CULVERT AT 143+74 IS PUT INTO SERVICE)

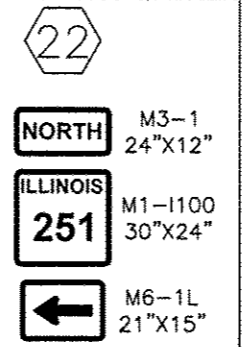

M3-1  
24"x12"

M1-1100  
30"x24"

M6-1L  
21"x15"

505+34.3, 39.4' RT \*  
510+47.0, 67.6' RT \*\*

\* MOUNT ON LIGHT POLE  
\*\* SIGNAL POLE MOUNTED

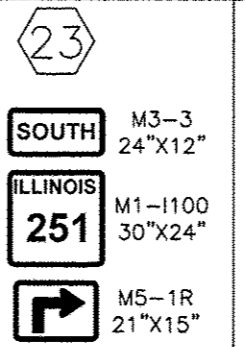

M3-3  
24"x12"

M1-1100  
30"x24"

M5-1R  
21"x15"

116+46.0, 31.9' RT \*

\* MOUNT ON LIGHT POLE

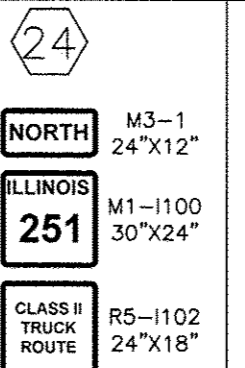

M3-1  
24"x12"

M1-1100  
30"x24"

R5-1102  
24"x18"

122+43.0, 39.3' LT \*

\* MOUNT ON LIGHT POLE

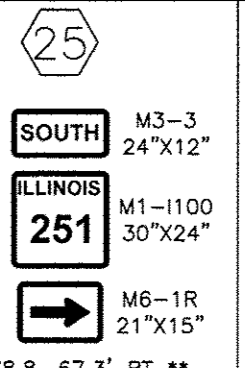

M3-3  
24"x12"

M1-1100  
30"x24"

M6-1R  
21"x15"

122+78.8, 67.3' RT \*\*

\*\* MAST ARM MOUNTED

PLANTING NOTES

- LANDSCAPE CONTRACTOR (CONTRACTOR) SHALL VISIT SITE, INSPECT EXISTING CONDITIONS AND REVIEW PROPOSED PLANTING AND RELATED WORK. IN CASE OF DISCREPANCY BETWEEN PLAN AND PLANT LIST, PLAN SHALL GOVERN QUANTITIES.
- CONTRACTOR SHALL VERIFY LOCATIONS OF ALL ON-SITE UTILITIES PRIOR TO BEGINNING CONSTRUCTION ON HIS PHASE OF WORK. ELECTRIC, GAS, TELEPHONE, AND CABLE TELEVISION MAY BE LOCATED BY CALLING J.U.L.L.E. AT '811'. ANY DAMAGE OR INTERRUPTION OF SERVICES SHALL BE THE RESPONSIBILITY OF CONTRACTOR. CONTRACTOR SHALL COORDINATE ALL RELATED ACTIVITIES WITH OTHER TRADES ON THE JOB AND REPORT ANY UNACCEPTABLE JOB CONDITIONS TO OWNER'S REPRESENTATIVE PRIOR TO COMMENCING WORK.
- CONTRACTOR RESPONSIBLE FOR APPLICATION AND COST OF ALL NECESSARY BUILDING PERMITS AND CODE VERIFICATIONS. SUBMIT COPIES OF ALL DOCUMENTS TO OWNER AND ARCHITECT.
- ALL SHRUB BEDS AND TREES SHALL BE MULCHED WITH A 3" CONTINUOUS LAYER OF SHREDDED BARK. ALL GROUND COVER AND PERENNIAL BEDS SHALL BE MULCHED WITH A 3" LAYER OF SHREDDED BARK. ALL DECIDUOUS TREES SHALL BE MULCHED WITH A 3" DIAMETER CIRCLE OF MULCH.
- CONTRACTOR SHALL GRADE ENTIRE SITE TO CORRECT SURFACE IRREGULARITIES IN PREPARATION FOR SEEDING ACTIVITIES. DISK, DRAG, HARROW, OR HAND RAKE SUBGRADE TO A DEPTH OF 6" IN ALL LAWN AREAS AND REMOVE STONES OR FOREIGN MATTER LARGER THAN 1-1/2". ALL AREAS TO BE SEEDING SHALL HAVE SMOOTH AND CONTINUAL GRADES, FREE FROM RIDGES AND DEPRESSIONS. ROLL RAKE AND LEVEL AS NECESSARY TO OBTAIN TRUE, EVEN LAWN SURFACES. SEED BEDS SHALL BE PERMITTED TO SETTLE, OR SHALL BE FIRMLY ROLLED BEFORE SEEDING BEGINS. FINISH GRADES SHALL MEET APPROVAL OF OWNER BEFORE GRASS SEED IS SOWN.
- ALL DISTURBED AREAS ARE TO RECEIVE MINIMUM 6" OF TOPSOIL IN ALL SEEDED LAWN AREAS AND 24" OF TOPSOIL IN ALL SHRUB AND PERENNIAL PLANTING BED AREAS IN ACCORDANCE WITH SECTION 211 OF THE STANDARD SPECIFICATIONS FOR ROAD AND BRIDGE CONSTRUCTION (ADOPTED JANUARY 1, 2012) ALL LAWN AREAS TO BE WATERED UNTIL A HEALTHY STAND OF GRASS IS ESTABLISHED (SEE NOTES 8 AND 9 FOR ACCEPTANCE OF GRASS).
- CONTRACTOR TO SEED ALL LAWN AREAS AS INDICATED ON PLAN. SEEDED LAWN TO BE IDOT CLASS 1A, SALT TOLERANT LAWN SEED, IN ACCORDANCE WITH SECTION 250 OF THE STANDARD SPECIFICATIONS FOR ROAD AND BRIDGE CONSTRUCTION (ADOPTED JANUARY 1, 2012) ALL SEEDED AREAS SHALL BE COVERED WITH EROSION CONTROL BLANKET (REFER TO SWPPP FOR ADDITIONAL INFORMATION).
- ALL SEEDED LAWN AREAS SHALL BE FERTILIZED AT INSTALLATION WITH A 26-26-26 ANALYSIS AT A RATE OF 270 LBS. PER ACRE IN ACCORDANCE WITH SECTION 250 OF THE STANDARD SPECIFICATIONS FOR ROAD AND BRIDGE CONSTRUCTION (ADOPTED JANUARY 1, 2012). ACCEPTANCE AND GUARANTEE NOTE SHALL APPLY TO ALL SEEDED LAWN AREAS.
- ACCEPTANCE OF GRADING AND SEEDING SHALL BE BY LANDSCAPE ARCHITECT AND/OR OWNER. THE CONTRACTOR SHALL ASSUME MAINTENANCE RESPONSIBILITIES FOR A MINIMUM OF SIXTY (60) DAYS OR UNTIL SECOND CUTTING, WHICHEVER IS LONGER. MAINTENANCE SHALL INCLUDE WATERING, WEEDING, RESEEDING, AND OTHER OPERATIONS NECESSARY TO KEEP ALL LAWN AREAS IN A THRIVING CONDITION. UPON FINAL ACCEPTANCE, OWNER SHALL ASSUME ALL MAINTENANCE RESPONSIBILITIES. AFTER LAWN AREAS HAVE GERMINATED, AREAS WHICH FAIL TO SHOW A UNIFORM STAND OF GRASS FOR ANY REASON WHATSOEVER SHALL BE RESEEDING REPEATEDLY UNTIL ALL AREAS ARE COVERED WITH A SATISFACTORY STAND OF GRASS. MINIMUM ACCEPTANCE OF SEEDED LAWN AREAS MAY INCLUDE SCATTERED BARE SPOTS, NONE OF WHICH ARE LARGER THAN 1 SQUARE FOOT, AND WHEN COMBINED DO NOT EXCEED 2% OF TOTAL SEEDED LAWN AREA.

PLANTING SCHEDULE

| KEY | QTY  | QTY  | Botanical name<br>COMMON NAME   | SIZE   | REMARKS         | PAY ITEM |
|-----|------|------|---|--------|-----------------|----------|
| AAB | 12   | EACH | Acer x freemani 'Autumn Blaze'<br>AUTUMN BLAZE MAPLE                            | 3"     | B & B           | A2000118 |
| BNH | 10   | EACH | Betula nigra 'Heritage'<br>HERITAGE RIVER BRCH                                  | 8"     | CLUMP FORM      | A2002470 |
| COH | 6    | EACH | Celtis occidentalis 'Chicagoland'<br>COMMON HACKBERRY                           | 3"     | B & B           | A2002884 |
| GTS | 5    | EACH | Gleditsia triacanthos 'Inermis'<br>SKYLINE HONEYLOCUST                          | 3"     | B & B           | A2004824 |
| OSW | 3    | EACH | Quercus bicolor<br>SWAMP WHITE OAK  | 3"     | B & B           | A2006524 |
| QBO | 4    | EACH | Quercus macrocarpa<br>BURR OAK  | 3"     | B & B           | A2006726 |
| TCG | 5    | EACH | Tilia cordata 'Greenspire'<br>GREENSPIRE LITTLELEAF LINDEN                      | 3"     | B & B           | A2008124 |
| AGA | 5    | EACH | Amelanchier x grandiflora 'Autumn Brilliance'<br>AUTUMN BRILLIANCE SERVICEBERRY | 8"     | SHRUB FORM      | B2000769 |
| CCR | 9    | EACH | Cercis canadensis<br>EASTERN REDBUD   | 3"     | B & B           | B2001124 |
| MLP | 9    | EACH | Malus x Profusion<br>PROFUSION CRABAPPLE  | 8"     | CLUMP FORM      | B2004170 |
| PCC | 26   | EACH | Pyrus calleryana 'Chanticleer'<br>CHANTICLEER PEAR                              | 3"     | B & B           | B2005726 |
| RAG | 56   | EACH | Rhus aromatica 'Gro-Low'<br>FRAGRANT GRO-LOW SUMAC                              | 24"    | CONTAINER       | C2C05824 |
| SJG | 266  | EACH | Spiraea japonica 'Goldmound'<br>GOLDMOUND SPIREA                                | 18"    | CONTAINER       | C2C10118 |
| LSA | 2.48 | UNIT | Leucanthemum x superba 'Alaska'<br>SHASTA DAISY                                 | 1 GAL. | ORNAMENTAL TYPE | K0012990 |
| CKF | 2.79 | UNIT | Calamagrostis acutifolia 'Karl Foerster'<br>KARL FOERSTER FEATHER RED GRASS     | 1 GAL. | PRAIRIE TYPE    | K0013020 |
| SHP | 2.41 | UNIT | Sporobolus heterolepis<br>PRAIRIE DROPSOED                                      | 1 GAL. | PRAIRIE TYPE    | K0013020 |
| SSB | 2.56 | UNIT | Schizachyrium scaparium 'The Blues'<br>THE BLUES LITTLE BLUESTEM                | 1 GAL. | PRAIRIE TYPE    | K0013020 |

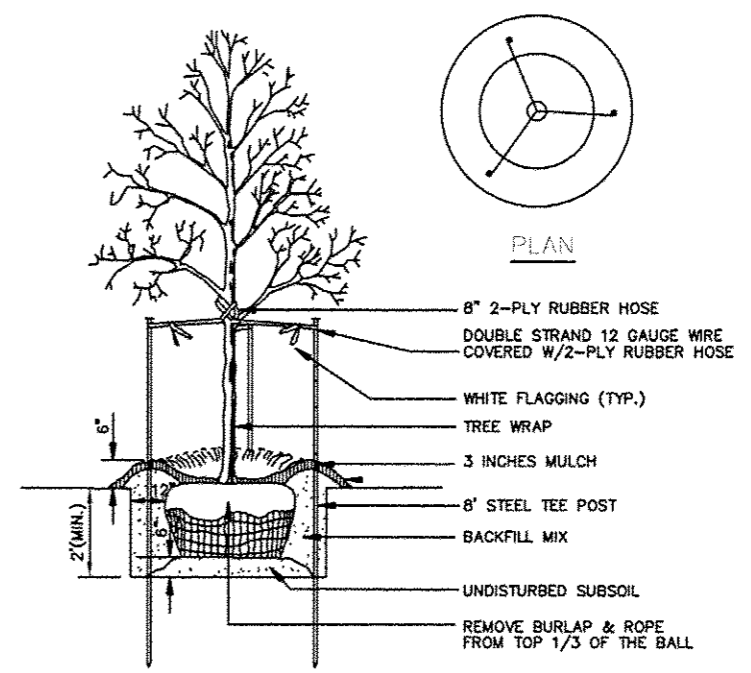

ALL TREES TO BE INSTALLED IN ACCORDANCE WITH SECTION 253 OF THE STANDARD SPECIFICATIONS FOR ROAD AND BRIDGE CONSTRUCTION (ADOPTED JANUARY 1, 2012)

**A TREE PLANTING DETAIL**  
329 NO SCALE

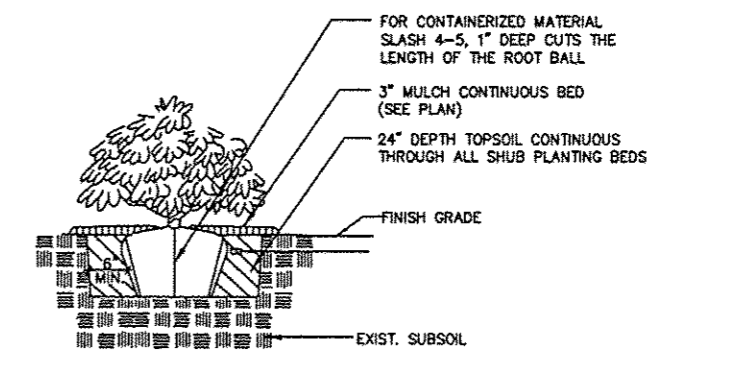

ALL SHRUBS TO BE INSTALLED IN ACCORDANCE WITH SECTION 253 OF THE STANDARD SPECIFICATIONS FOR ROAD AND BRIDGE CONSTRUCTION (ADOPTED JANUARY 1, 2012)

**B SHRUB PLANTING DETAIL**  
329 NO SCALE

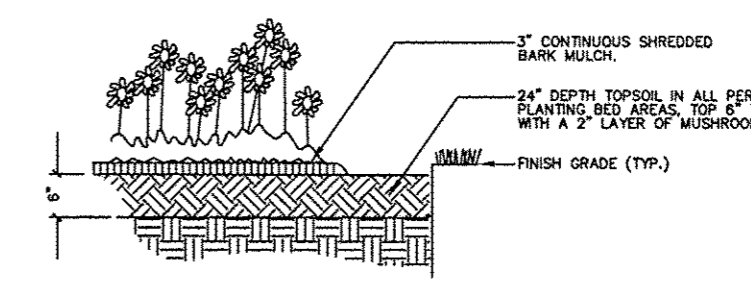

ALL PERENNIALS TO BE INSTALLED IN ACCORDANCE WITH SECTION 254 OF THE STANDARD SPECIFICATIONS FOR ROAD AND BRIDGE CONSTRUCTION (ADOPTED JANUARY 1, 2012)

**C PERENNIAL PLANTING DETAIL**  
329 NO SCALE

| REVISIONS |             |      |
|-----------|-------------|------|
| REV. NO.  | DESCRIPTION | DATE |
|           |             |      |
|           |             |      |
|           |             |      |

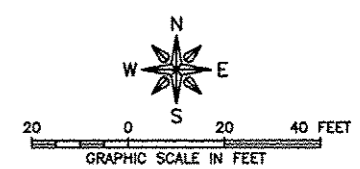
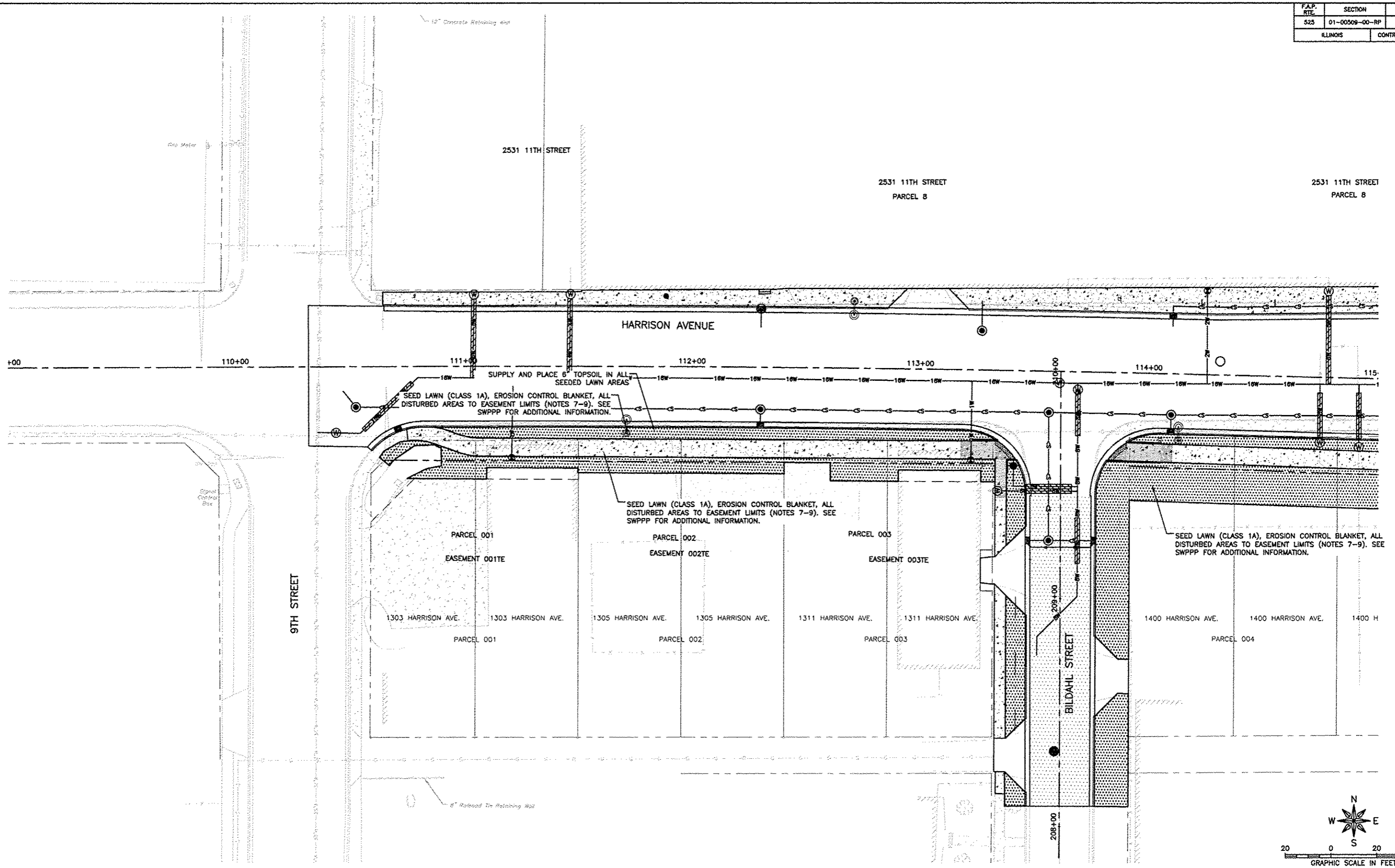

| REVISIONS |             |      |
|-----------|-------------|------|
| REV. NO.  | DESCRIPTION | DATE |
|           |             |      |
|           |             |      |
|           |             |      |

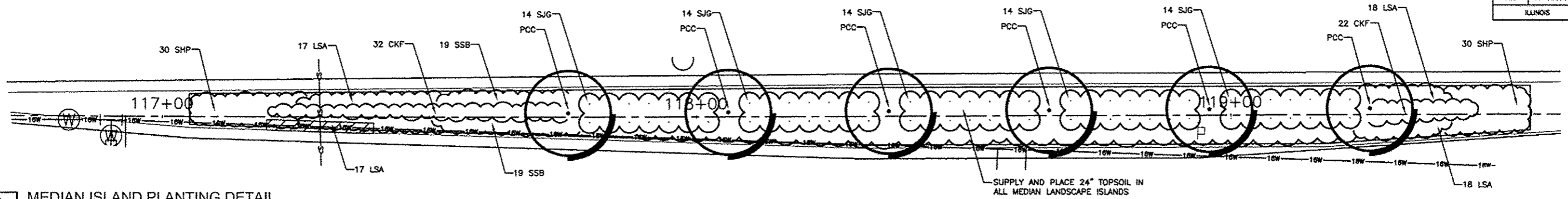

**A** MEDIAN ISLAND PLANTING DETAIL  
331 SCALE: 1" = 10'-0"

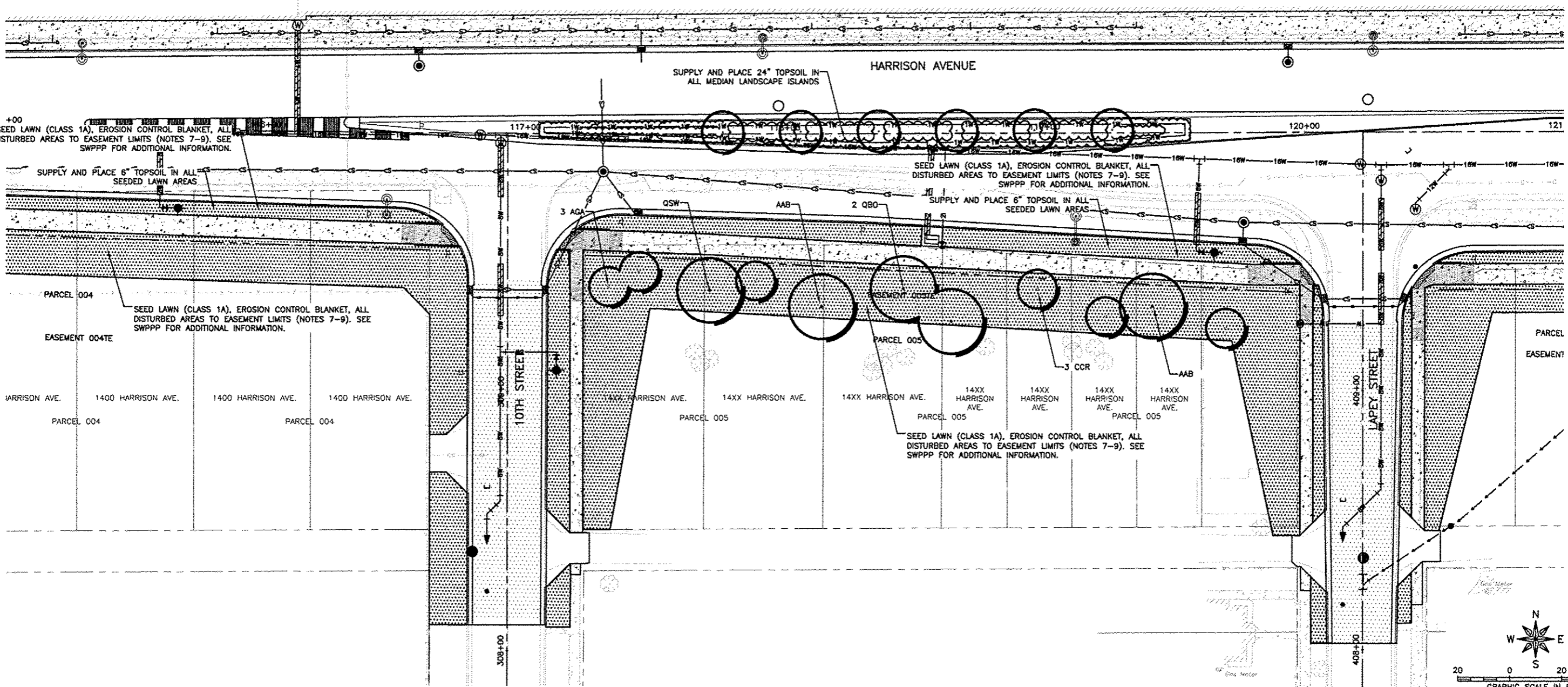

| REVISIONS |             |      |
|-----------|-------------|------|
| REV. NO.  | DESCRIPTION | DATE |
|           |             |      |
|           |             |      |
|           |             |      |

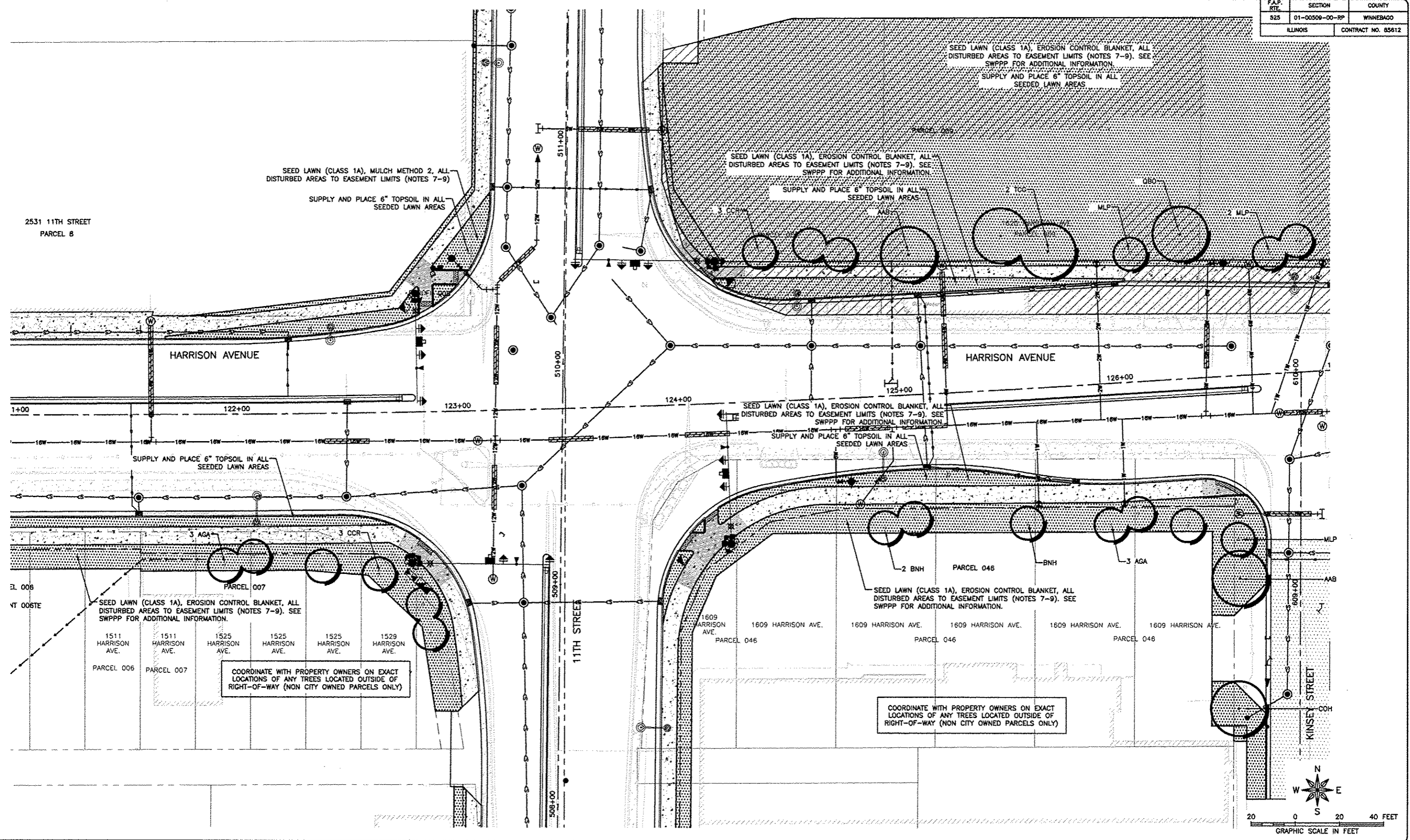

**FEHR GRAHAM**  
ENGINEERING & ENVIRONMENTAL  
ILLINOIS DESIGN FIRM NO. 184-003525  
© 2015 FEHR GRAHAM

ILLINOIS  
IOWA  
WISCONSIN

**sanders design group**  
landscape architecture • planning • site design

PROJECT AND LOCATION:  
HARRISON AVENUE RECONSTRUCTION  
IL 251 AND FAP 0525  
11TH STREET TO 20TH STREET

DRAWN BY: SLS  
APPROVED BY: SLS  
DATE: 06/12/2015  
SCALE: 1" = 20'-0"

| REVISIONS |             |      |
|-----------|-------------|------|
| REV. NO.  | DESCRIPTION | DATE |
|           |             |      |
|           |             |      |
|           |             |      |

DRAWING:  
LANDSCAPE PLAN  
HARRISON AVENUE AND SIDE STREETS

JOB NUMBER:  
11-126

SHEET NUMBER:  
332 of 588



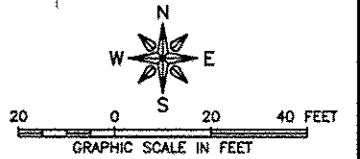
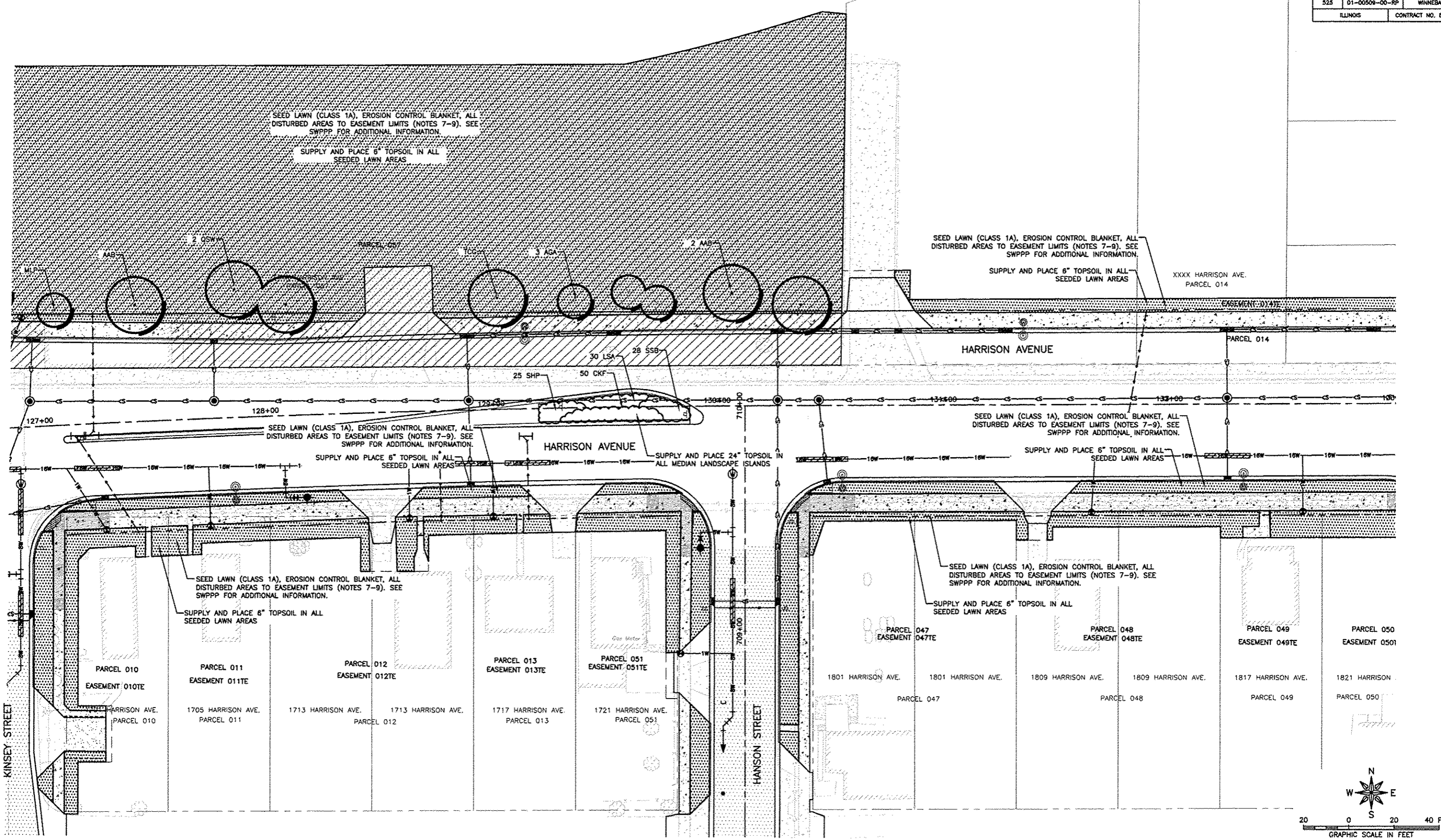

| REVISIONS |             |      |
|-----------|-------------|------|
| REV. NO.  | DESCRIPTION | DATE |
|           |             |      |
|           |             |      |
|           |             |      |

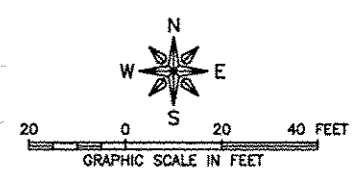
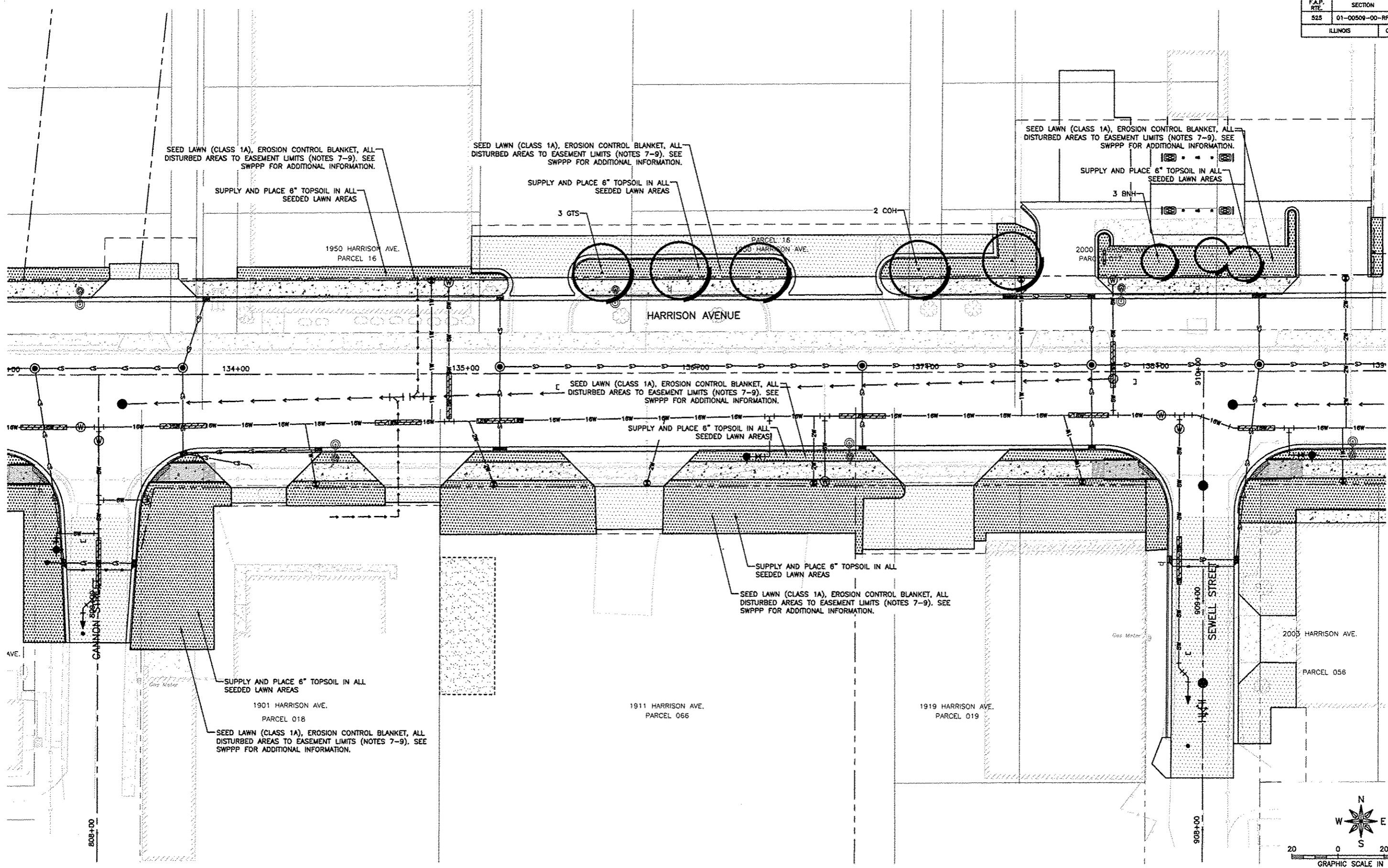

| REVISIONS |             |      |
|-----------|-------------|------|
| REV. NO.  | DESCRIPTION | DATE |
|           |             |      |
|           |             |      |
|           |             |      |

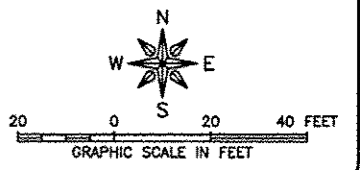
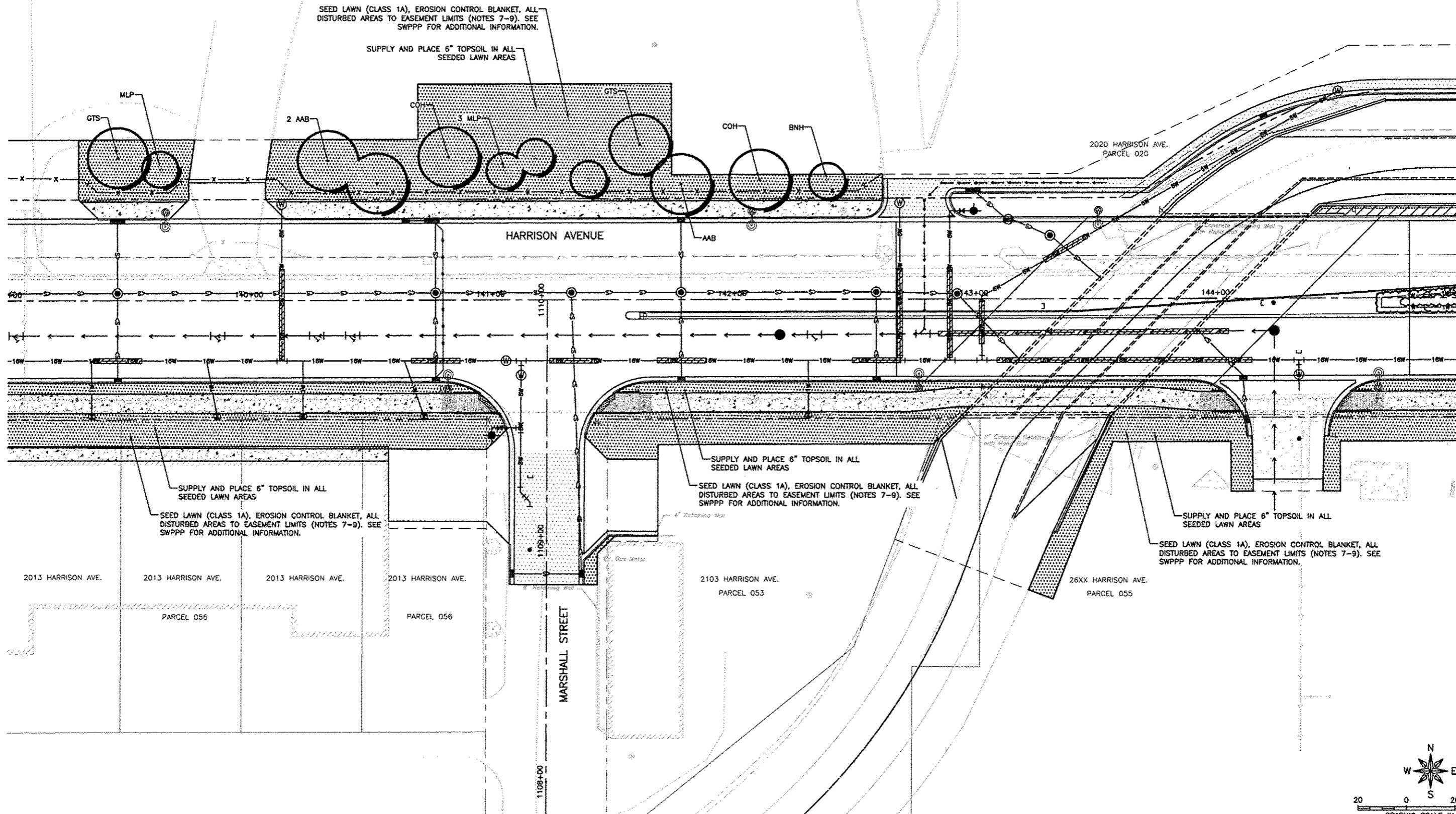

| REVISIONS |             |      |
|-----------|-------------|------|
| REV. NO.  | DESCRIPTION | DATE |
|           |             |      |
|           |             |      |
|           |             |      |

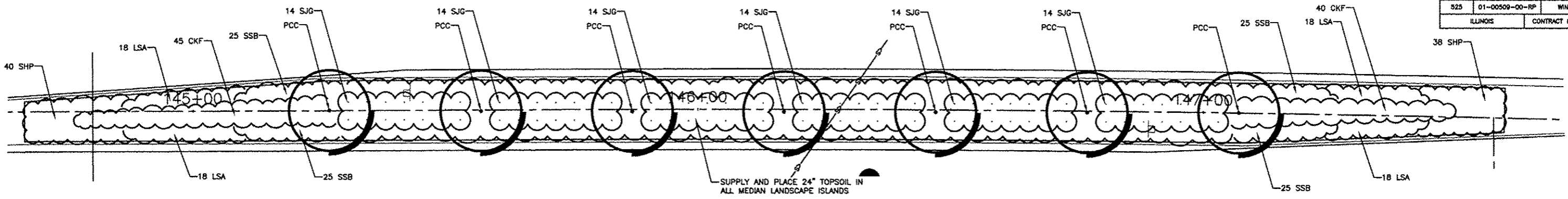

**A** MEDIAN ISLAND PLANTING DETAIL  
 336 SCALE: 1" = 10'-0"

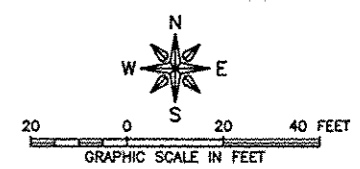
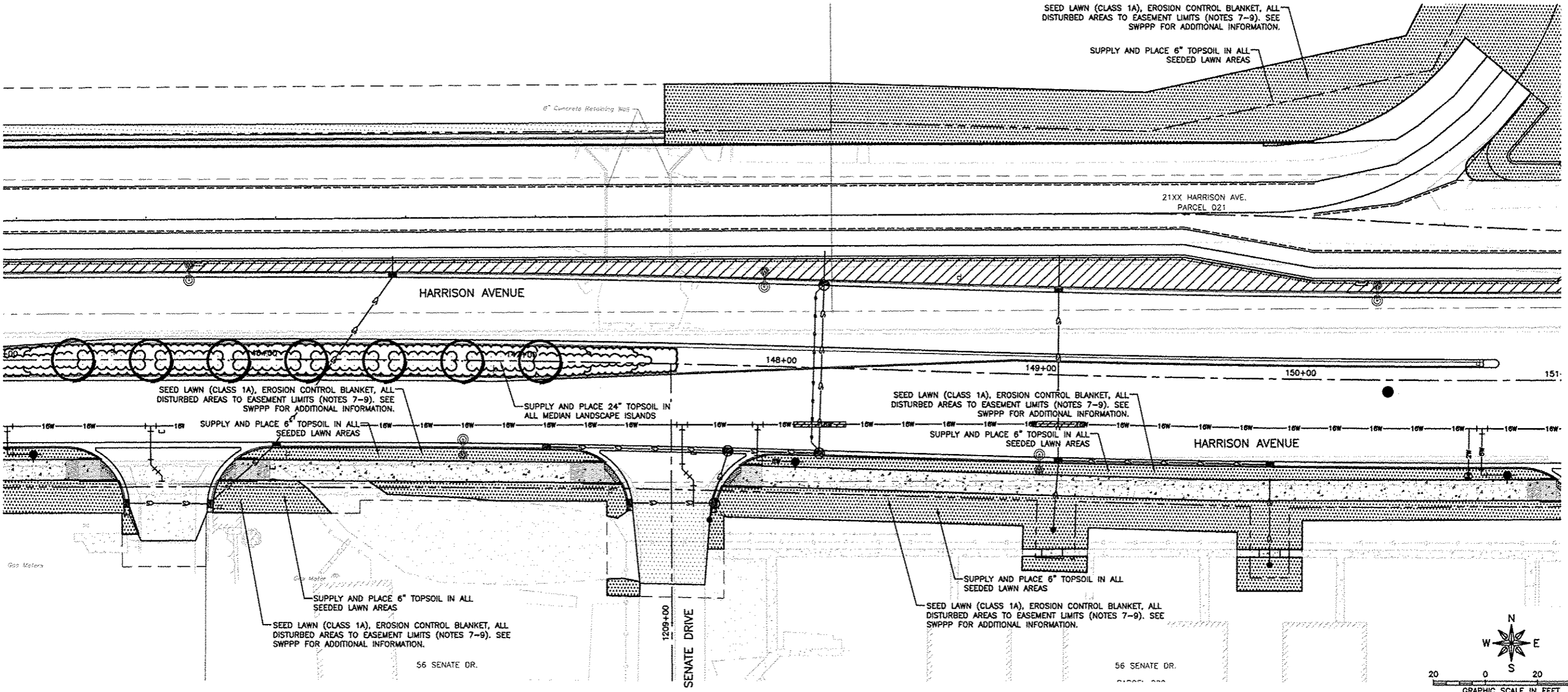

| REVISIONS |             |      |
|-----------|-------------|------|
| REV. NO.  | DESCRIPTION | DATE |
|           |             |      |
|           |             |      |
|           |             |      |

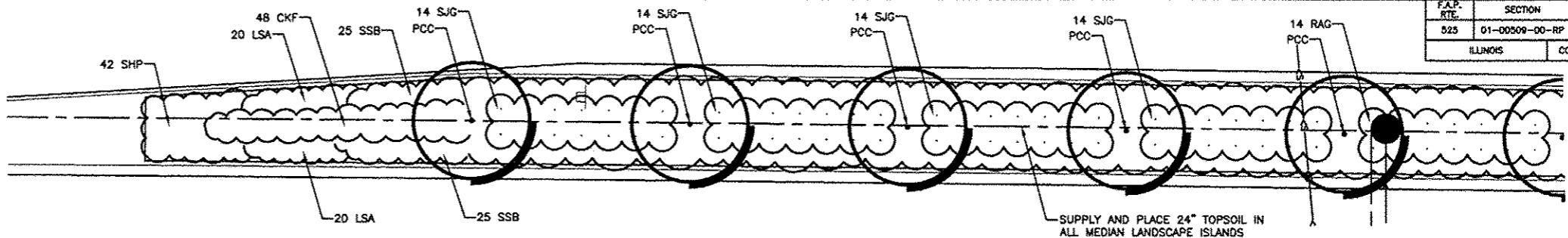

**A** MEDIAN ISLAND PLANTING DETAIL  
 337 SCALE: 1" = 10'-0"

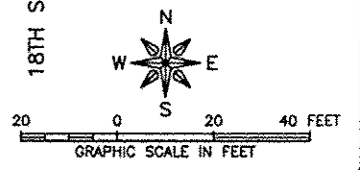
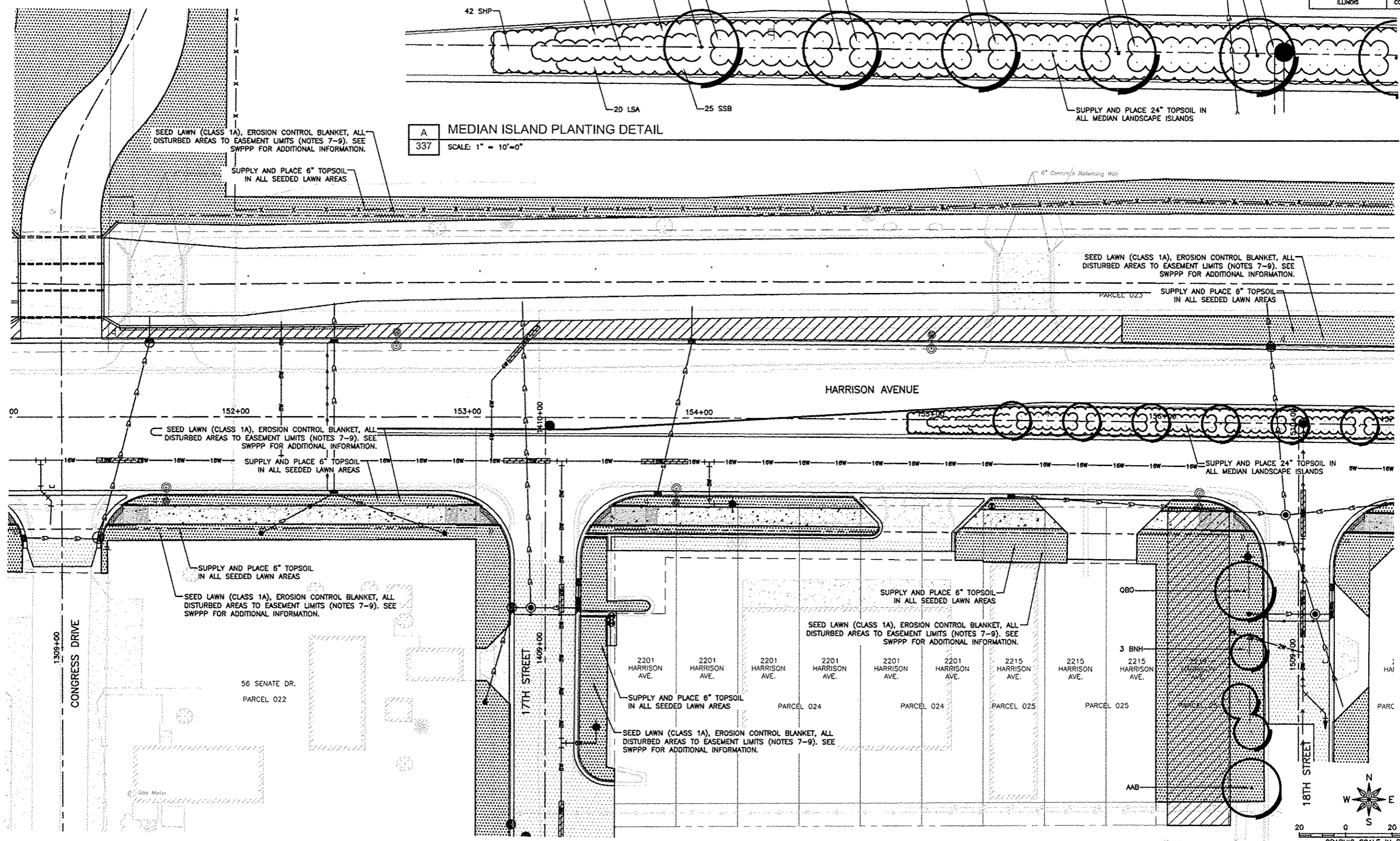

| REVISIONS |             |      |
|-----------|-------------|------|
| REV. NO.  | DESCRIPTION | DATE |
|           |             |      |
|           |             |      |
|           |             |      |

|                   |                           |                     |
|-------------------|---------------------------|---------------------|
| F.A.P. RTE<br>325 | SECTION<br>01-00509-00-RP | COUNTY<br>WINNEBAGO |
| ILLINOIS          |                           | CONTRACT NO. 85812  |

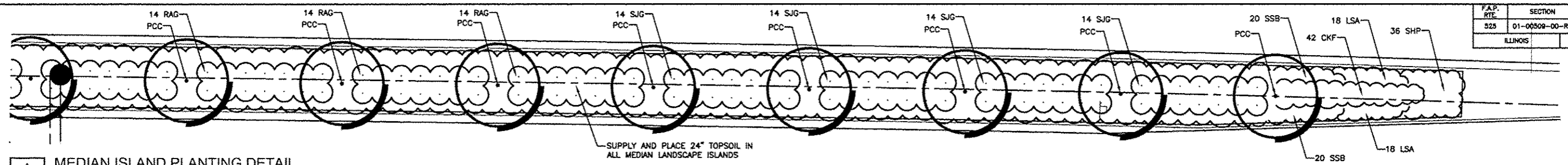

**A** MEDIAN ISLAND PLANTING DETAIL  
338 SCALE: 1" = 10'-0"

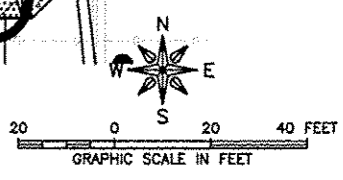
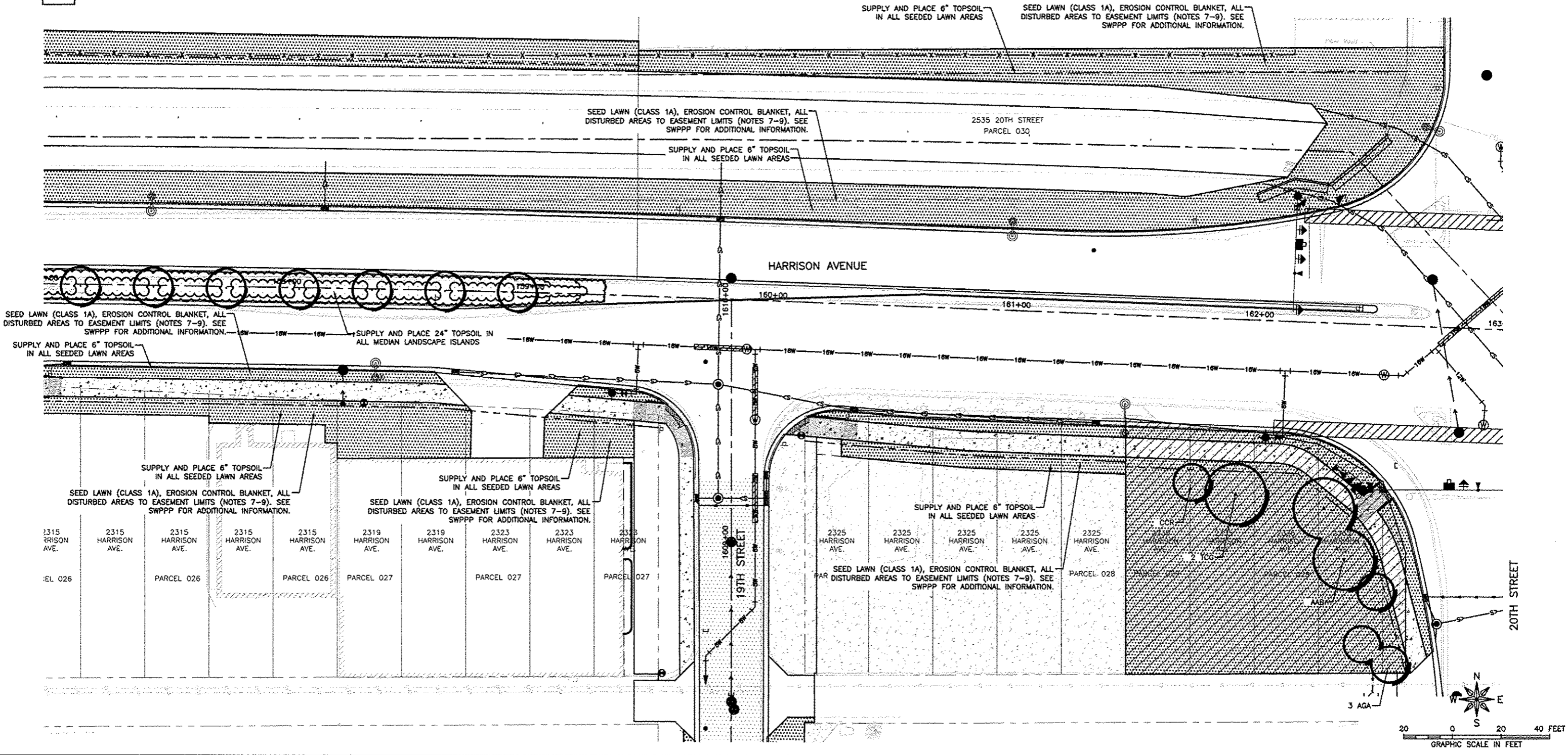

| REVISIONS |             |      |
|-----------|-------------|------|
| REV. NO.  | DESCRIPTION | DATE |
|           |             |      |
|           |             |      |
|           |             |      |

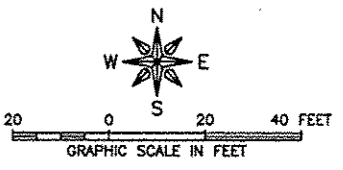
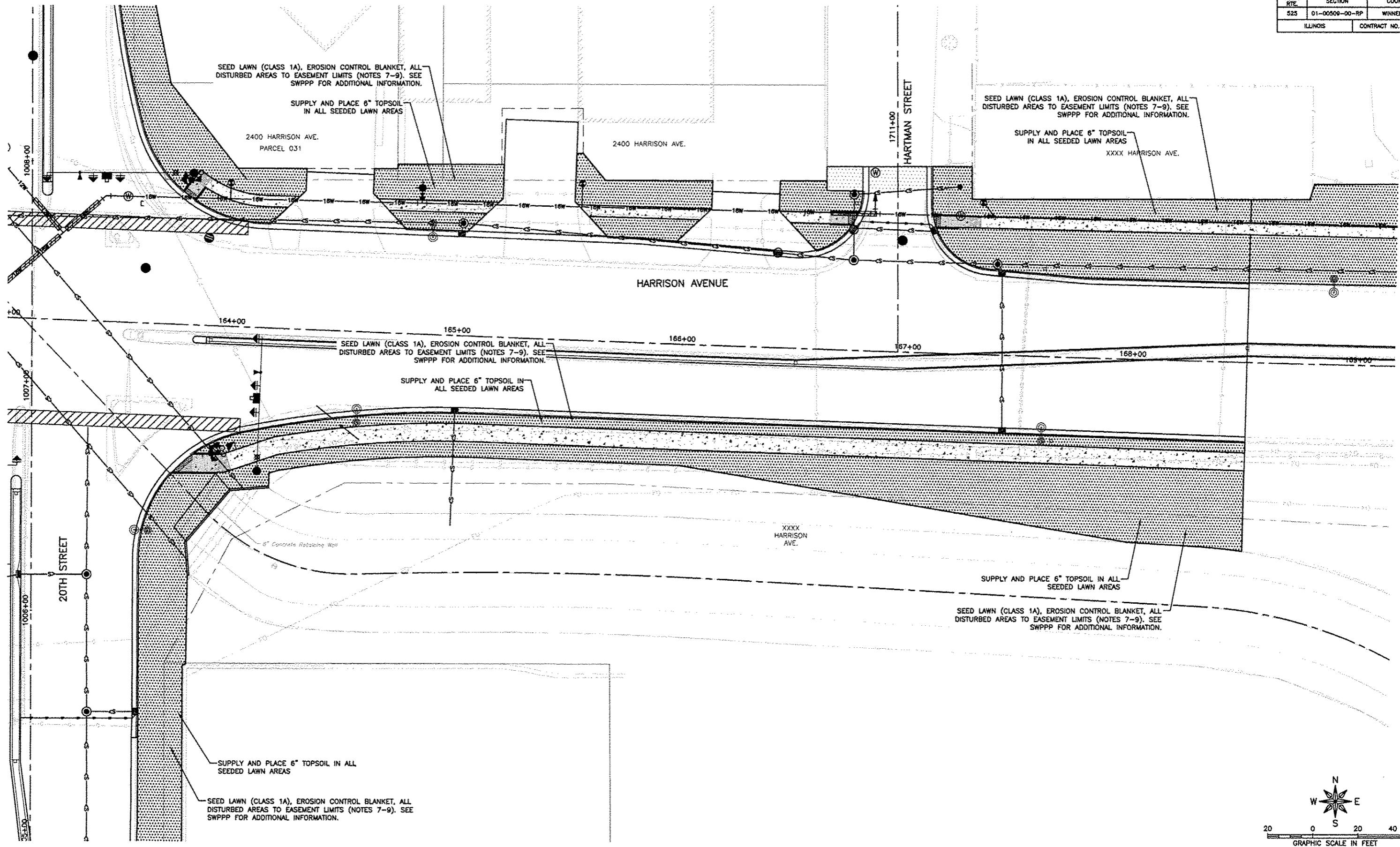

| REVISIONS |             |      |
|-----------|-------------|------|
| REV. NO.  | DESCRIPTION | DATE |
|           |             |      |
|           |             |      |
|           |             |      |

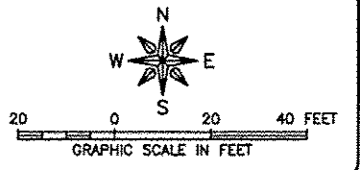
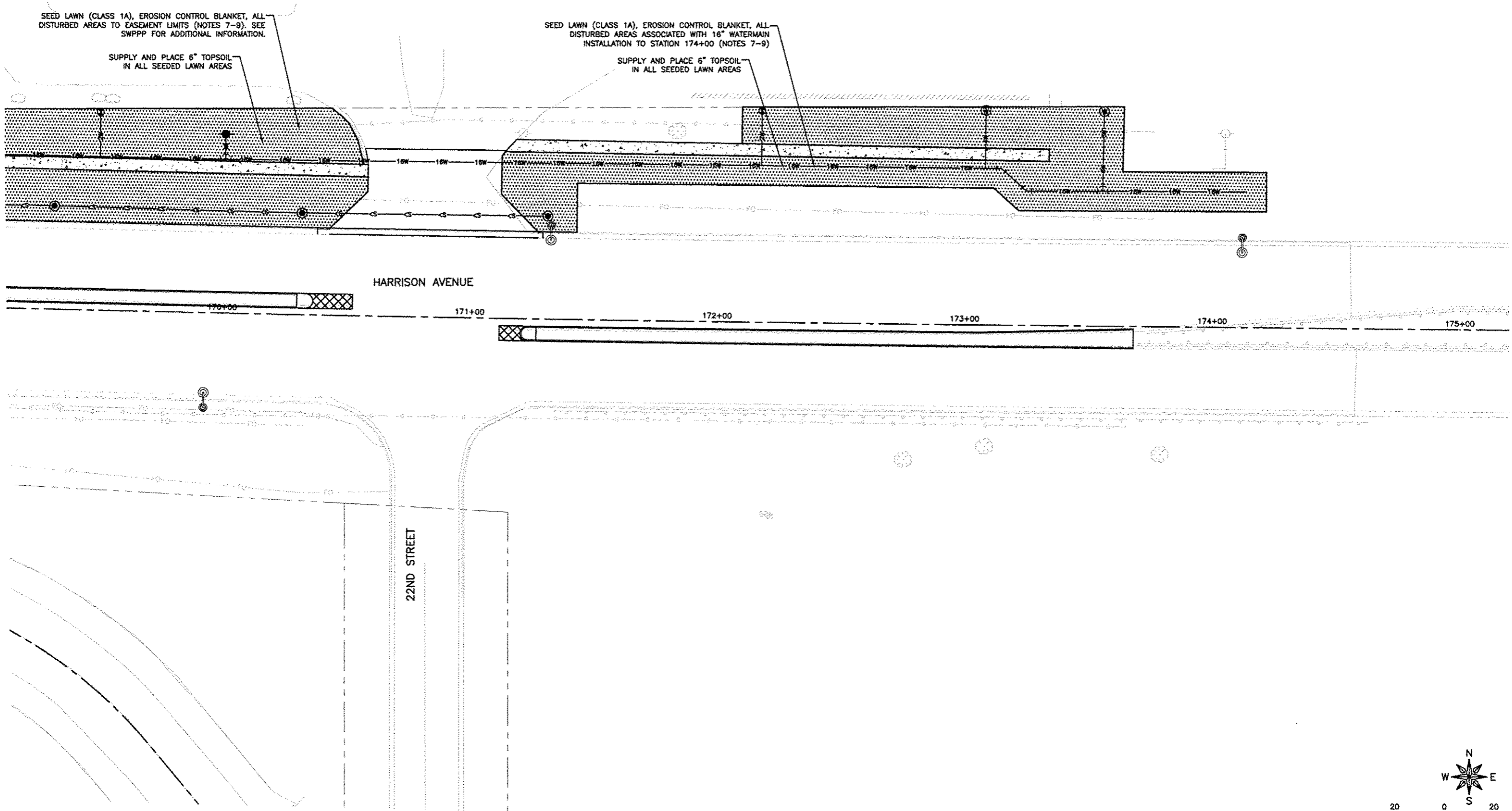

| REVISIONS |             |      |
|-----------|-------------|------|
| REV. NO.  | DESCRIPTION | DATE |
|           |             |      |
|           |             |      |
|           |             |      |



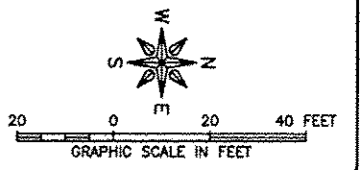
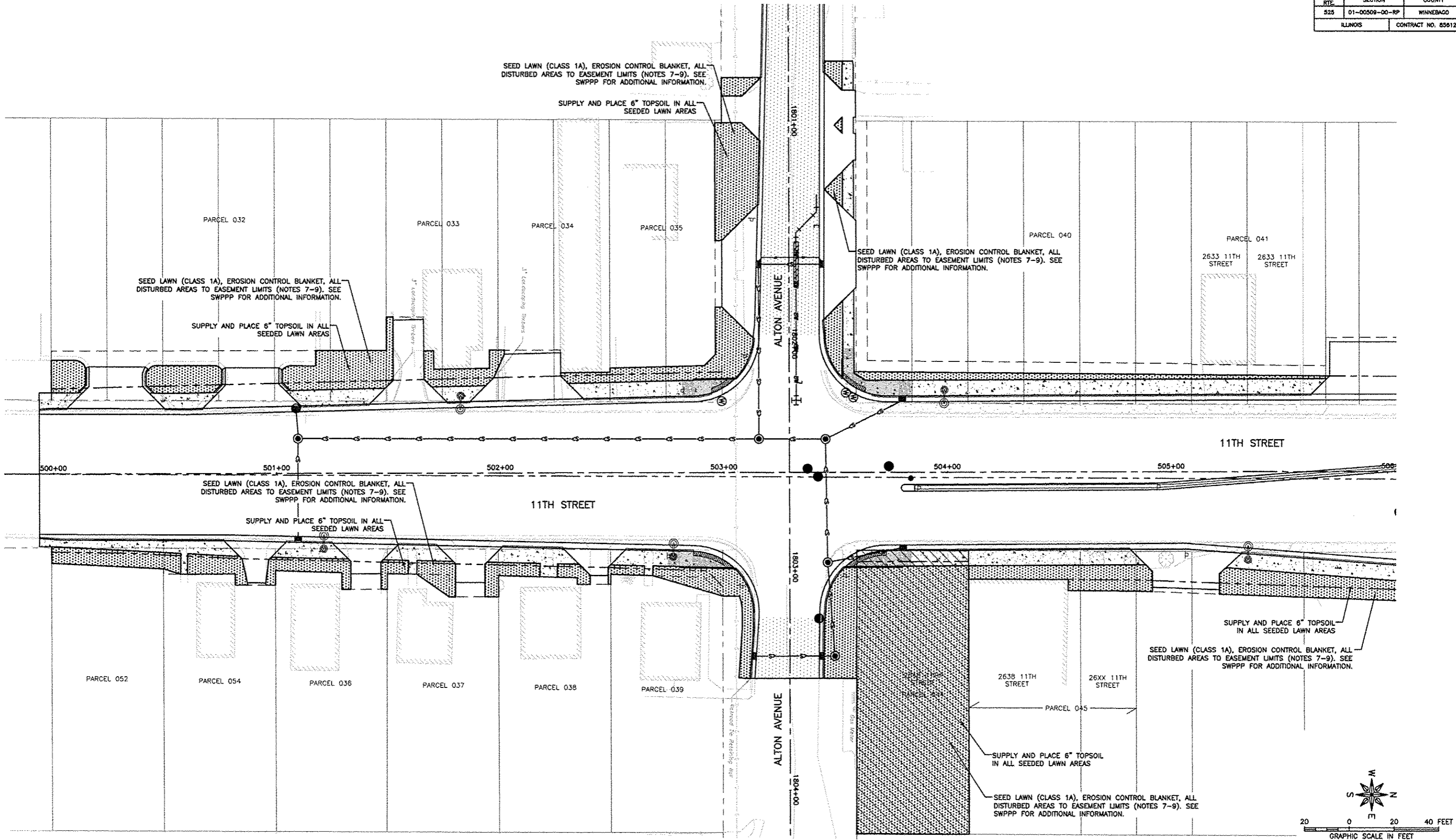

| REVISIONS |             |      |
|-----------|-------------|------|
| REV. NO.  | DESCRIPTION | DATE |
|           |             |      |
|           |             |      |
|           |             |      |

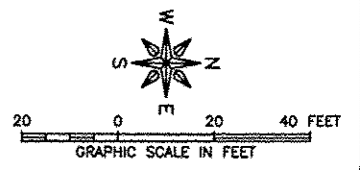
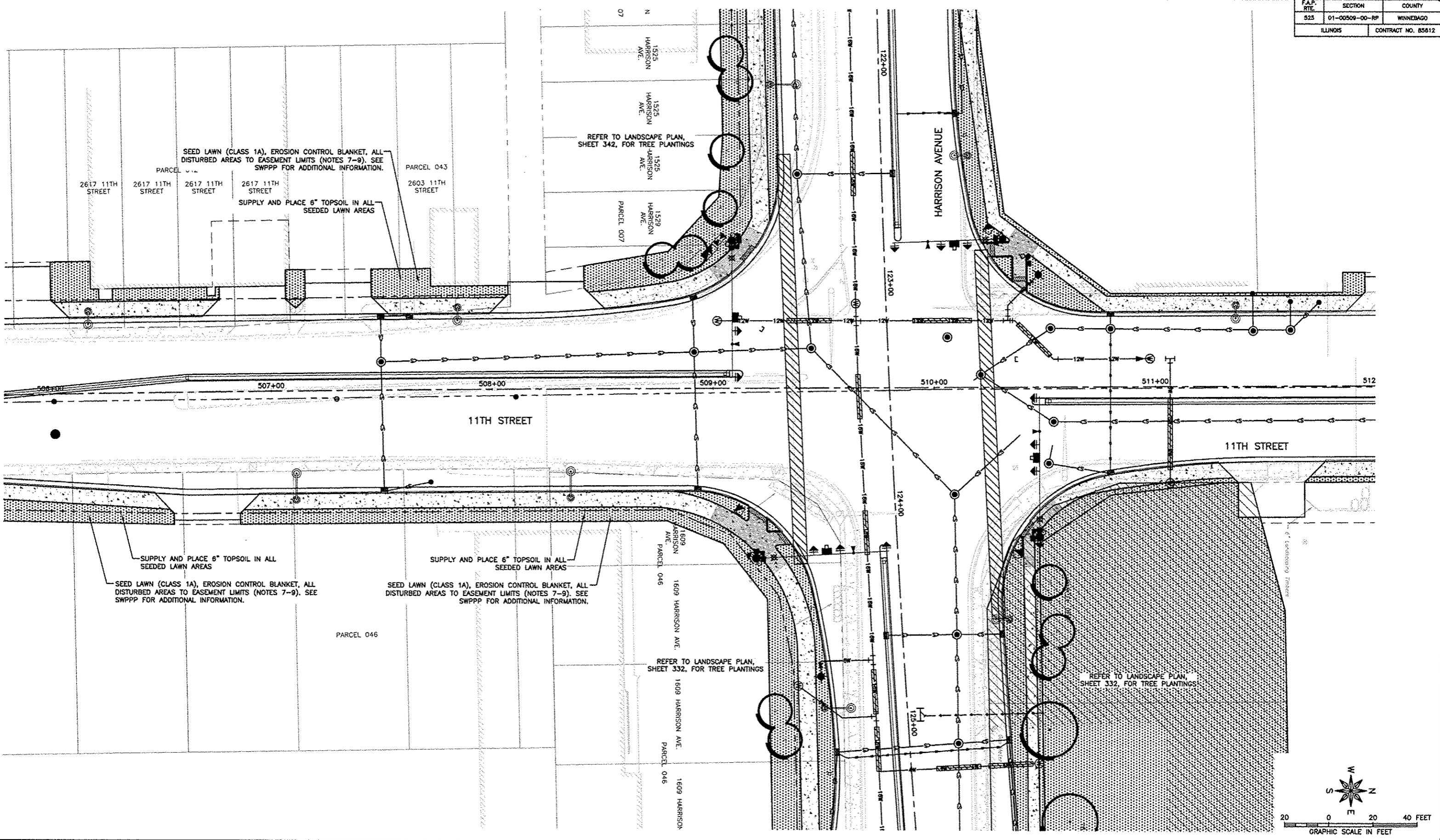

| REVISIONS |             |      |
|-----------|-------------|------|
| REV. NO.  | DESCRIPTION | DATE |
|           |             |      |
|           |             |      |
|           |             |      |

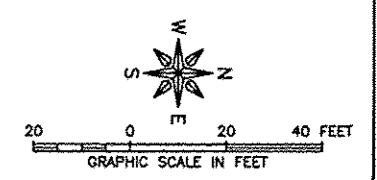
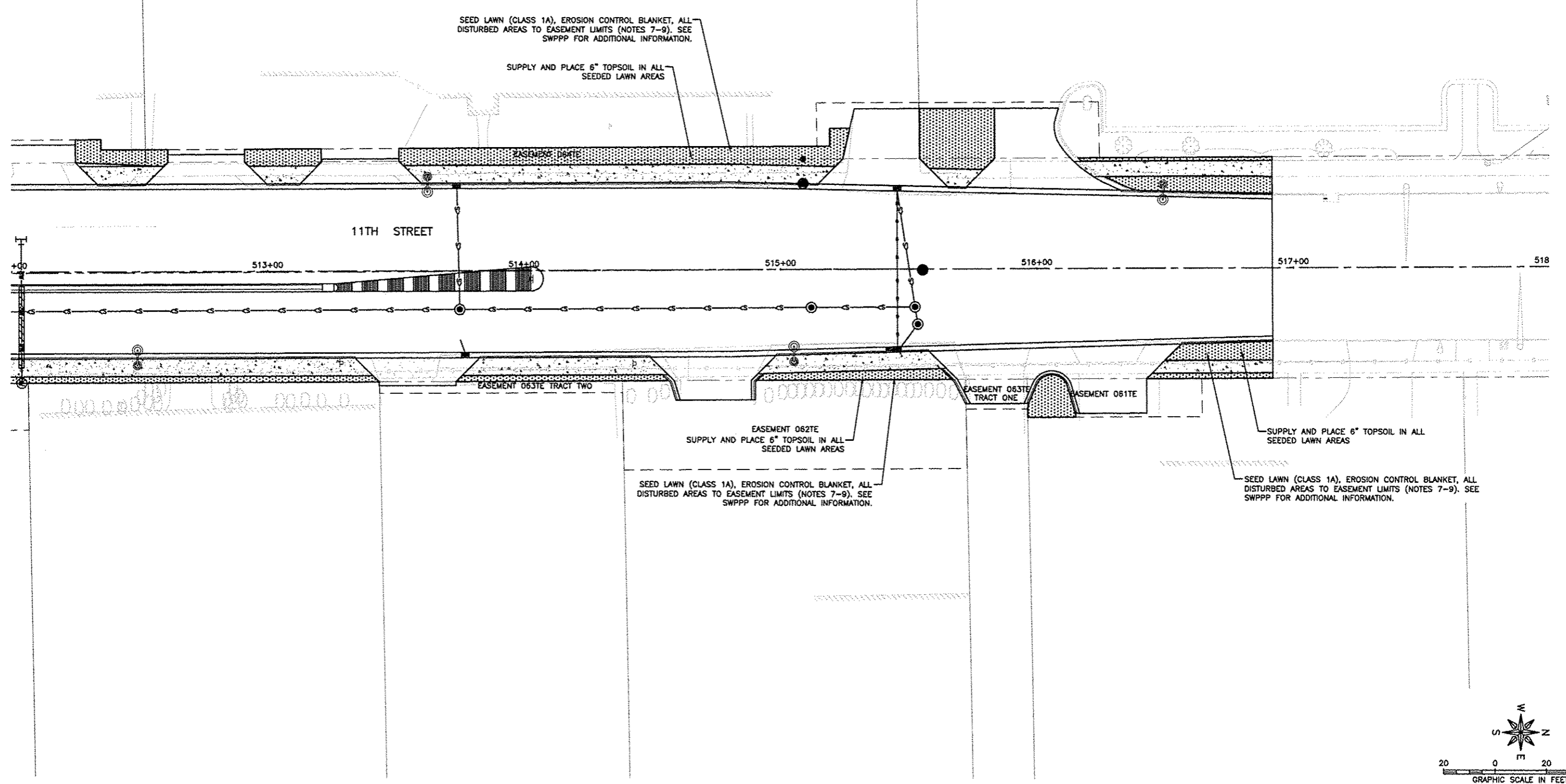

| REVISIONS |             |      |
|-----------|-------------|------|
| REV. NO.  | DESCRIPTION | DATE |
|           |             |      |
|           |             |      |
|           |             |      |

2535  
20TH STREET

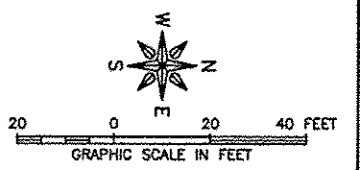
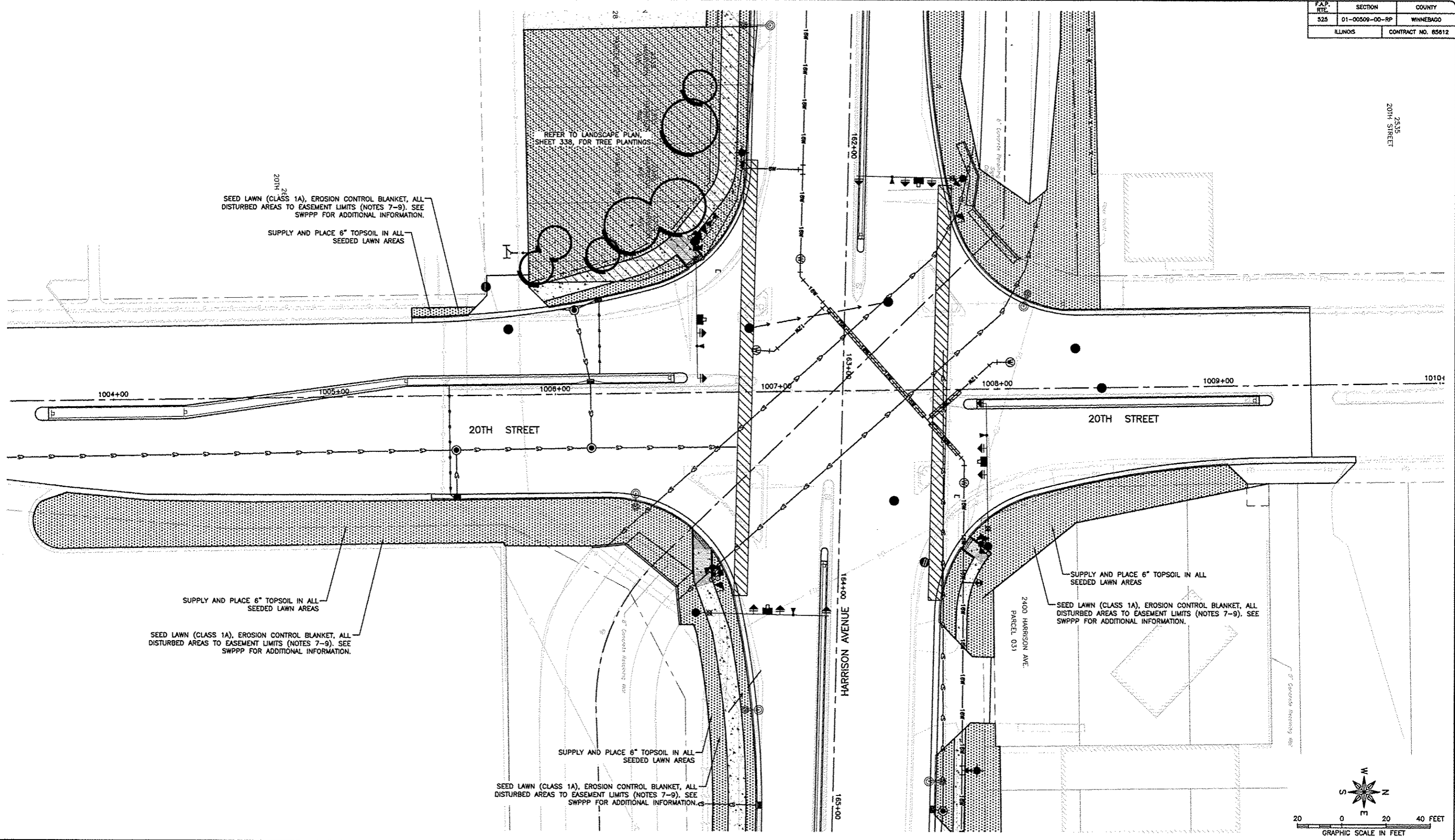

| REVISIONS |             |      |
|-----------|-------------|------|
| REV. NO.  | DESCRIPTION | DATE |
|           |             |      |
|           |             |      |
|           |             |      |

IRRIGATION NOTES

- IRRIGATION CONTRACTOR (CONTRACTOR) SHALL VERIFY ALL DIMENSIONS AND AREAS PRIOR TO BEGINNING PROJECT. INTENT IS FOR FULL COVERAGE OF LAWN AREA. NOTIFY ARCHITECT OF ANY DISCREPANCIES.
- CONTRACTOR SHALL VERIFY LOCATIONS OF ALL ON-SITE UTILITIES PRIOR TO BEGINNING CONSTRUCTION ON HIS PHASE OF WORK. ELECTRIC, GAS, TELEPHONE, AND CABLE TELEVISION MAY BE LOCATED BY CALLING J.U.L.I.E. AT 811. ANY DAMAGE OR INTERRUPTION OF SERVICES SHALL BE THE RESPONSIBILITY OF THE CONTRACTOR. CONTRACTOR SHALL COORDINATE ALL RELATED ACTIVITIES WITH OTHER TRADES ON THE JOB AND SHALL REPORT ANY UNACCEPTABLE JOB CONDITIONS TO OWNER'S REPRESENTATIVE PRIOR TO COMMENCING WORK.
- MAIN LINE SHALL BE 2" CLASS 40 PVC AT A MINIMUM DEPTH OF 12" BELOW FINISHED GRADE. LATERAL LINES SHALL BE 1" POLY PIPE AT A MINIMUM DEPTH OF 8" BELOW FINISHED GRADE.
- BACKFILL SHALL BE FREE FROM ROCK AND THOROUGHLY TAMPED AND COMPACTED IN ALL TRENCHES. TRENCHES SHALL NOT BE LEFT OPEN OVERNIGHT. CONTRACTOR SHALL BE RESPONSIBLE FOR DAMAGE BY ANY SETTLED TRENCHES, FOR REPAIRS OF LAWNS, DRIVEWAYS OR OTHER STRUCTURES.
- LOCATE ALL EQUIPMENT AS SHOWN, EXCEPT WHERE EXISTING CONDITIONS PROHIBIT. MINOR CHANGES THAT BETTER SUIT FIELD COVERAGE WILL BE PERMITTED. PLAN IS DIAGRAMMATIC. MAIN LINE AND LATERAL LINES SHOULD BE RUN IN ONE (1) TRENCH WHERE POSSIBLE. VALVES SHALL BE LOCATED DIRECTLY ON MAIN LINE.
- VALVES TO BE INSTALLED IN "AMETEK" POLYPLASTIC BOXES (OR EQUAL), 12" X 8" X 18". INSTALL VALVES FLUSH WITH ADJACENT GRADE, WHETHER IN PLANTING BEDS OR LAWNS. USE 3" DEPTH PEA GRAVEL IN BASE OF ALL VALVE BOXES. GROUP VALVES WHERE POSSIBLE.
- INSTALL SPRAY HEADS 2" ABOVE GRADE AND 6" FROM CURBS, WALKS, OR OTHER STRUCTURES.
- AFTER SYSTEM IS INSTALLED, REMOVE END HEADS AND OPERATE SYSTEM AT FULL PRESSURE UNTIL ALL RUST, SCALE AND SAND IS REMOVED.
- ALL REMOTE CONTROL VALVE CABLE TO BE #18 U.F., OR #14 U.F., MULTI-STRAND, DIRECT BURIAL TAPE AND BUNDLE AT 20' INTERVALS. RUN ALL WIRE IN PIPE TRENCH WHERE POSSIBLE.
- IT IS ASSUMED THAT EXISTING PRESSURE AT THE POINT OF CONNECTION IS ADEQUATE TO SUPPLY THE SYSTEM. IF EXISTING PRESSURE IS INADEQUATE, CONTRACTOR TO INFORM OWNER AND ARCHITECT IMMEDIATELY.
- TEST SYSTEM TO DETERMINE THAT ALL SPRINKLERS FUNCTION ACCORDING TO MANUFACTURER'S SPECIFICATIONS AND GIVE FULL COVERAGE ACCORDING TO INTENT OF DRAWING. REPLACE, ADJUST, OR ADD HEADS, VALVES, AND OTHER ITEMS NECESSARY TO ATTAIN FULL COVERAGE WITHOUT ADDITIONAL COST TO OWNER.
- CONTRACTOR TO COORDINATE ENTIRE SYSTEM INSTALLATION WITH OTHER TRADES ON THE JOB.
- UPON COMPLETION OF PROJECT, CONTRACTOR TO PROVIDE A COMPLETE AND "AS BUILT" IRRIGATION PLAN SHOWING THE PLACEMENT OF ALL HEADS, VALVES, PIPING, AND ASSOCIATED HARDWARE. ZONE LAYOUT TO BE INDICATED IN RELATIONSHIP TO CONTROLLER. ANY CHANGES IN HEAD LOCATIONS FROM ORIGINAL PLAN SHOULD ALSO BE NOTED.
- CONTRACTOR IS RESPONSIBLE FOR ALL PERMITS AND APPROVALS REQUIRED TO MEET LOCAL CODES AND ORDINANCES.
- FOR SYSTEMS INSTALLED DURING SPRING OR SUMMER CONSTRUCTION, CONTRACTOR SHALL MAKE SYSTEM FULLY OPERATIONAL AND PROVIDE FALL WINTERIZATION AND NEXT SEASON'S SPRING CHARGING AND INSPECTION OF SYSTEM.  
FOR SYSTEMS INSTALLED LATE SUMMER AND FALL, PROVIDE LATE FALL WINTERIZATION, NEXT SPRING START-UP AND THE FOLLOWING SEASON'S WINTERIZATION.
- ANY MEASURES REQUIRED TO MAKE THE SYSTEM OPERATIONAL SHALL BE INCLUDED IN THE PRICE OF THE INSTALLATION CONTRACT, AND SHALL BE COORDINATED WITH OWNER AND/OR ARCHITECT ON-SITE.

IRRIGATION SCHEDULE

| SYM  | QTY        | ITEM                                  | MODEL NO.                        |
|------|------------|---------------------------------------|----------------------------------|
| ==== | 463 L.F.   | 4" C-900 PVC SLEEVE                   |                                  |
| ---- | 1,015 L.F. | 2" CLASS 40 PVC IRRIGATION MAINLINE   |                                  |
| [C]  | 2          | HUNTER 'ICC' 20 ZONE CONTROLLER       | ICC-800-PL                       |
| [M]  | 2          | 2" BRASS MASTER VALVE                 |                                  |
| [2]  | TBD        | HUNTER HPV SOLENOID CONTROL VALVE     |                                  |
| [S]  | TBD        | HUNTER PRO SPRAY SHRUB HEAD 180 SPRAY | PROS-06-CV-10H<br>PROS-06-CV-12H |
| [S]  | TBD        | HUNTER PRO SPRAY SHRUB HEAD 90 SPRAY  | PROS-06-CV-10Q<br>PROS-06-CV-12Q |

CONTRACTOR SHALL INSTALL VALVES AND HEADS IN SUFFICIENT QUANTITIES TO PROVIDE HEAD TO HEAD COVERAGE THROUGHOUT EXTENTS OF MEDIAN LANDSCAPE ISLANDS AS INDICATED ON PLANS.

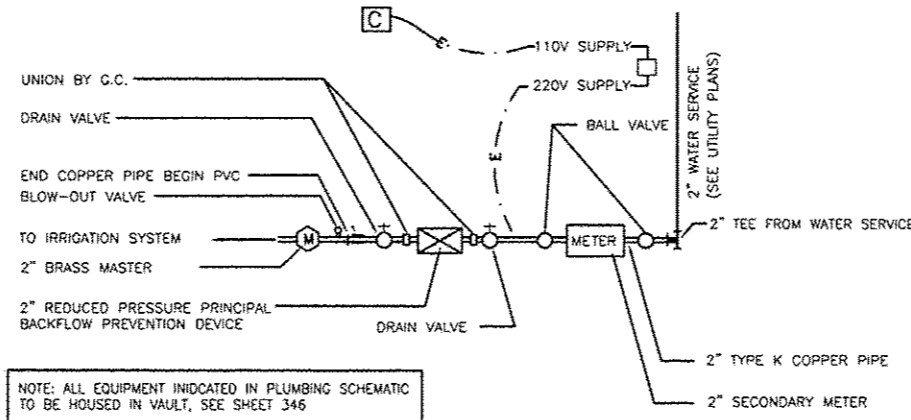

A IRRIGATION PLUMBING SCHEMATIC  
345 SCALE: 1" = 10'-0"

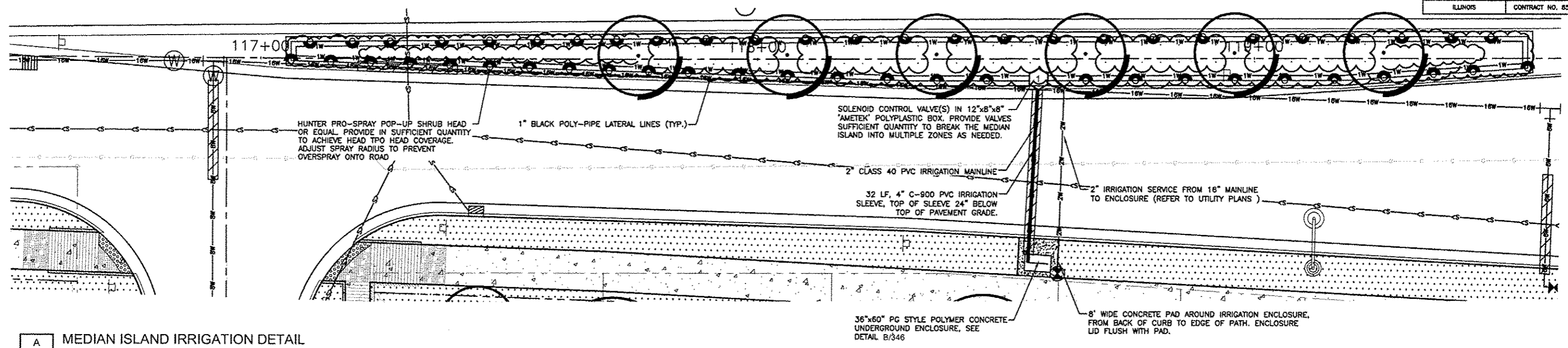

**A** MEDIAN ISLAND IRRIGATION DETAIL  
346 SCALE: 1" = 10'-0"

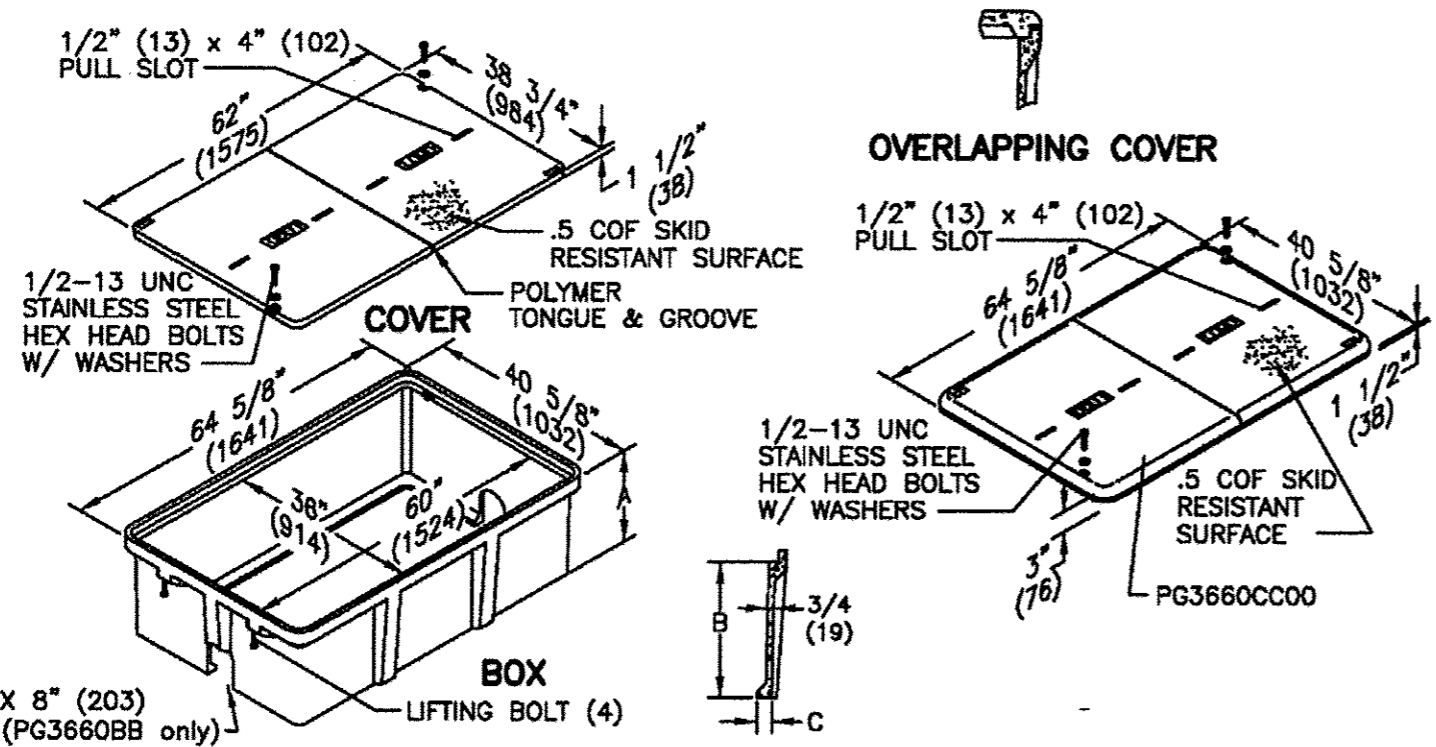

**B** IRRIGATION ENCLOSURE DETAIL  
346 NTS

**Covers (Blank unless logo is specified)**

| DESCRIPTION                  | PART NO.   | WEIGHT #       | DESIGN/TEST LOAD # | ANSI TIER* |
|------------------------------|------------|----------------|--------------------|------------|
| Lightweight w/2 Bolts        | LG3660CA00 | 222 (100.7 kg) | 5,000 / 7,500      | 5          |
| Lightweight w/No Bolts       | LG3660WA00 | 222 (100.7 kg) | 5,000 / 7,500      | 5          |
| Heavy Duty w/2 Bolts         | PG3660HA00 | 384 (174.0 kg) | 15,000 / 22,500    | 15         |
| Extra Heavy Duty w/2 Bolts   | PG3660HH00 | 470 (213.2 kg) | 22,500 / 33,750    | 22         |
| Lightweight Overlapping      | LG3660CC00 | 307 (139.3 kg) | 5,000 / 7,500      | 5          |
| Heavy Duty 2 pc. Overlapping | PG3660HC00 | 438 (197.8 kg) | 15,000 / 22,500    | 15         |

\* Covers with meter lids available upon request. See page 12 or page 56 for meter lid cover load rating explanation.

**Boxes (Stackable with self-aligning, replaceable nut) \*31" & 36" deep boxes must be used as bottom of any stack**

| DESCRIPTION                 | PART NO.   | WEIGHT #       | DIMENSION A        | DIMENSION B      | DIMENSION C | DESIGN/TEST LOAD # | ANSI TIER* |
|-----------------------------|------------|----------------|--------------------|------------------|-------------|--------------------|------------|
| Open Bottom                 | PG3660BA19 | 381 (172.8 kg) | 19 1/2" (495 mm)   | 18" (457 mm)     | 2" (51 mm)  | 22,500 / 33,750    | 22         |
|                             | PG3660BA24 | 397 (180.0 kg) | 24" (610 mm)       | 22 1/2" (572 mm) | 2" (51 mm)  | 22,500 / 33,750    | 22         |
|                             | PG3660BA31 | 481 (218.2 kg) | 31" (787 mm)       | 29 1/2" (749 mm) | 2" (51 mm)  | 22,500 / 33,750    | 22         |
|                             | PG3660BA36 | 647 (293.0 kg) | 36" (914 mm)       | 34 1/2" (876 mm) | 2" (51 mm)  | 22,500 / 33,750    | 22         |
| Open Bottom w/ 2 Mouseholes | PG3660BB19 | 379 (171.9 kg) | 19 1/2" (495.0 mm) | 18" (457 mm)     | 2" (51 mm)  | 22,500 / 33,750    | 22         |
|                             | PG3660BB24 | 397 (180.0 kg) | 24" (610 mm)       | 22 1/2" (572 mm) | 2" (51 mm)  | 22,500 / 33,750    | 22         |
|                             | PG3660BB31 | 479 (217.3 kg) | 31" (787 mm)       | 29 1/2" (749 mm) | 2" (51 mm)  | 22,500 / 33,750    | 22         |
|                             | PG3660BB36 | 647 (293.0 kg) | 36" (914 mm)       | 34 1/2" (876 mm) | 2" (51 mm)  | 22,500 / 33,750    | 22         |
| Solid Bottom                | PG3660DA19 | 479 (217.0 kg) | 20" (508 mm)       | 18 1/2" (470 mm) | N/A         | 22,500 / 33,750    | 22         |
|                             | PG3660DA24 | 495 (224.5 kg) | 24 1/2" (622 mm)   | 23" (584 mm)     | N/A         | 22,500 / 33,750    | 22         |
|                             | PG3660DA31 | 590 (268.0 kg) | 31 1/2" (800.1 mm) | 30" (762 mm)     | N/A         | 22,500 / 33,750    | 22         |
|                             | PG3660DA36 | 738 (334.8 kg) | 38 1/2" (977 mm)   | 35" (889 mm)     | N/A         | 22,500 / 33,750    | 22         |

**Extensions (For use on top of box only)**

| DESCRIPTION | PART NO.   | WEIGHT #      | DIMENSION A | DIMENSION B | DIMENSION C | DESIGN/TEST LOAD # | ANSI TIER* |
|-------------|------------|---------------|-------------|-------------|-------------|--------------------|------------|
| Open Bottom | PG3660EA12 | 209 (90.7 kg) | 11 1/2"     | 10"         | 2"          | 22,500 / 33,750    | 22         |

Dimensions & weights in parentheses are metric equivalent.  
\* Loadings comply with ANSI/SCTE 77 (see page 9).

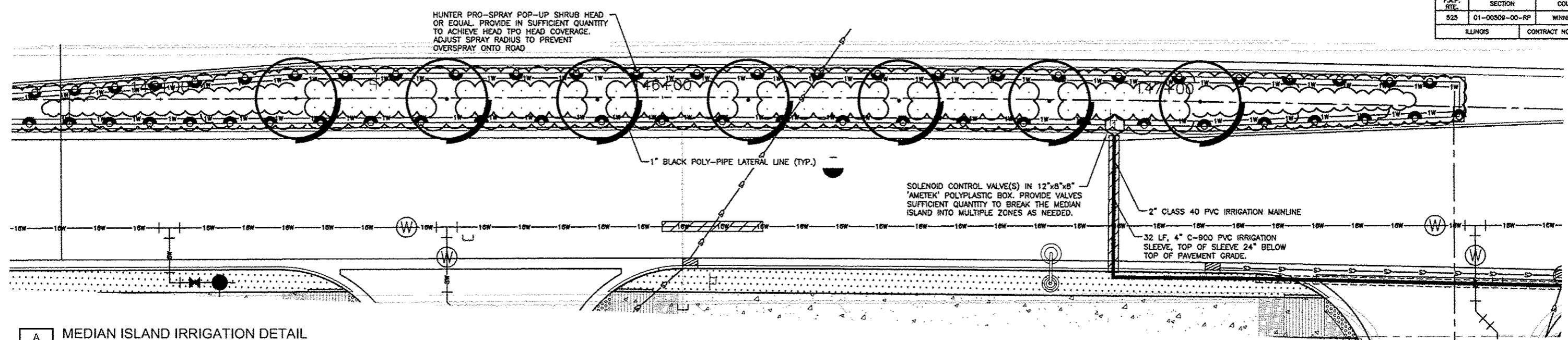

**A** MEDIAN ISLAND IRRIGATION DETAIL  
347 SCALE: 1" = 10'-0"

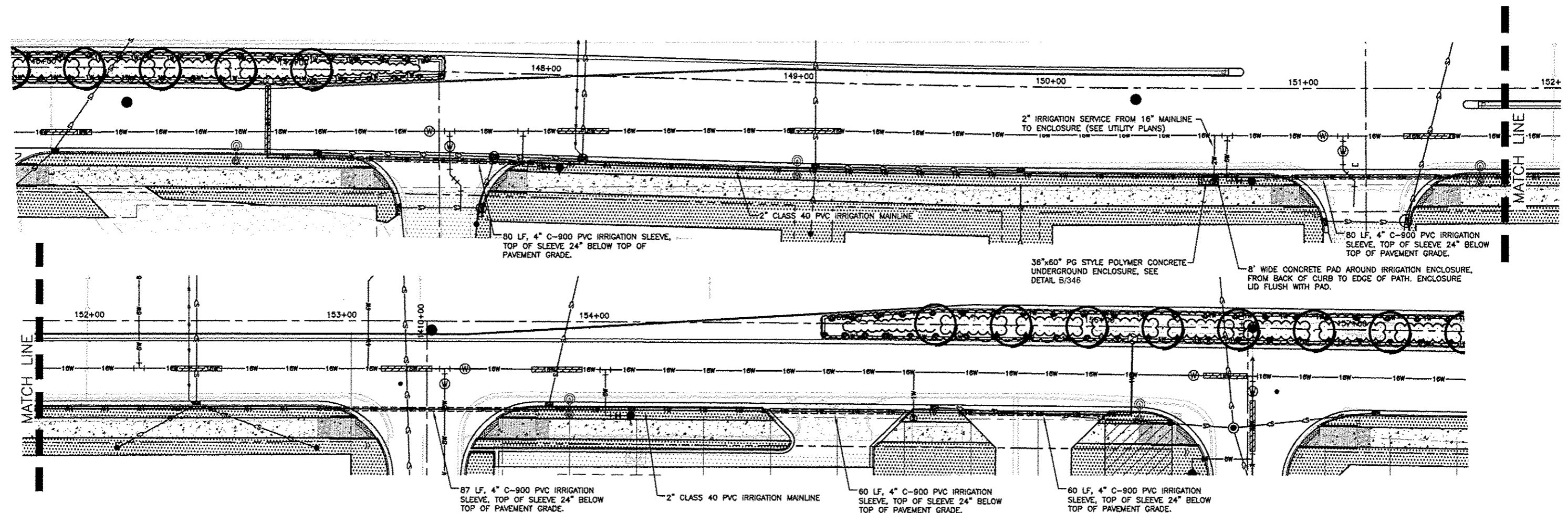

**B** EASTERN MEDIAN ISLANDS IRRIGATION MAINLINE  
347 SCALE: 1" = 20'-0"

| REVISIONS |             |      |
|-----------|-------------|------|
| REV. NO.  | DESCRIPTION | DATE |
|           |             |      |
|           |             |      |
|           |             |      |

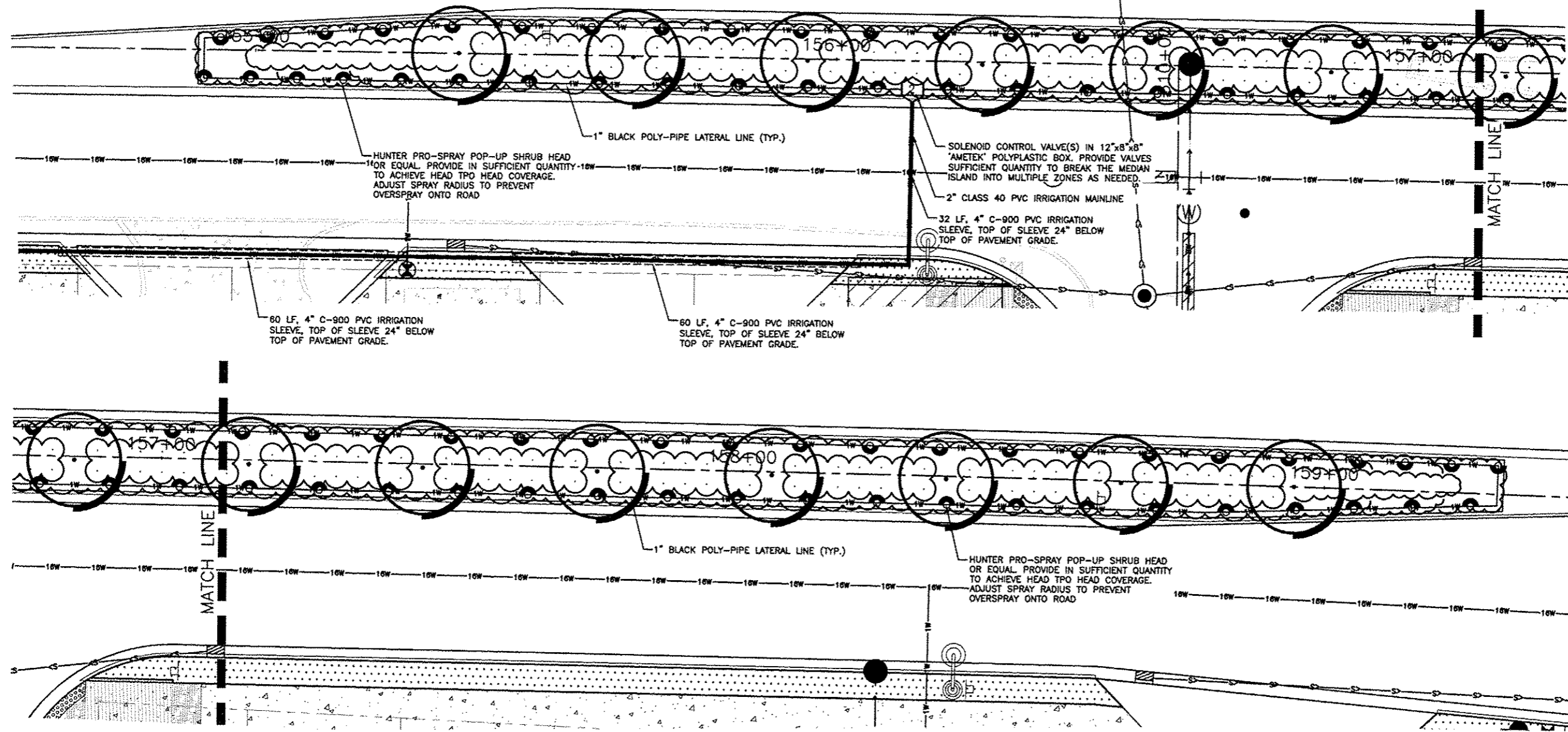

A MEDIAN ISLAND IRRIGATION DETAIL  
348 SCALE: 1" = 10'-0"

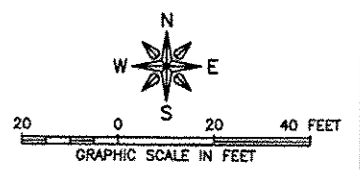

| REVISIONS |             |      |
|-----------|-------------|------|
| REV. NO.  | DESCRIPTION | DATE |
|           |             |      |
|           |             |      |
|           |             |      |



**TRAFFIC SIGNAL LEGEND**

- PROPOSED SERVICE INSTALLATION
  - PROPOSED CONTROLLER CABINET
  - PROPOSED HANDHOLE
  - PROPOSED MAST ARM AND POLE WITH LUMINAIRE
  - PROPOSED TRAFFIC SIGNAL POST
  - PROPOSED SIGNAL FACE
  - PROPOSED SIGNAL FACE WITH BACKPLATE
  - PROPOSED PEDESTRIAN SIGNAL HEAD WITH COUNTDOWN TIMERS
  - PROPOSED PEDESTRIAN PUSH-BUTTON
  - ▲ PROPOSED EMERGENCY PREEMPTION
  - PROPOSED VIDEO VEHICLE DETECTION SYSTEM
  - - - PROPOSED CONDUIT
  - [55'] PROPOSED MAST ARM LENGTH
- PVC POLYVINYL CHLORIDE CONDUIT
  - CN COILABLE, NON-METALLIC CONDUIT
  - B BORED AND PULLED
  - T TRENCHED
  - CT COMMON TRENCHED
  - LENGTH-E-SIZE EXISTING CONDUIT LENGTH - CONDUIT SIZE
  - LENGTH METHOD PROPOSED CONDUIT LENGTH - METHOD
  - SIZE TYPE CONDUIT SIZE - TYPE
  - STA STATION
  - OFF OFFSET
- NOTE: ALL STA & OFFSETS ARE FROM HARRISON AVENUE

|             |                |                    |
|-------------|----------------|--------------------|
| F.A.P. RTE. | SECTION        | COUNTY             |
| 525         | 01-00509-00-RP | WINNEBAGO          |
| ILLINOIS    |                | CONTRACT NO. 85612 |

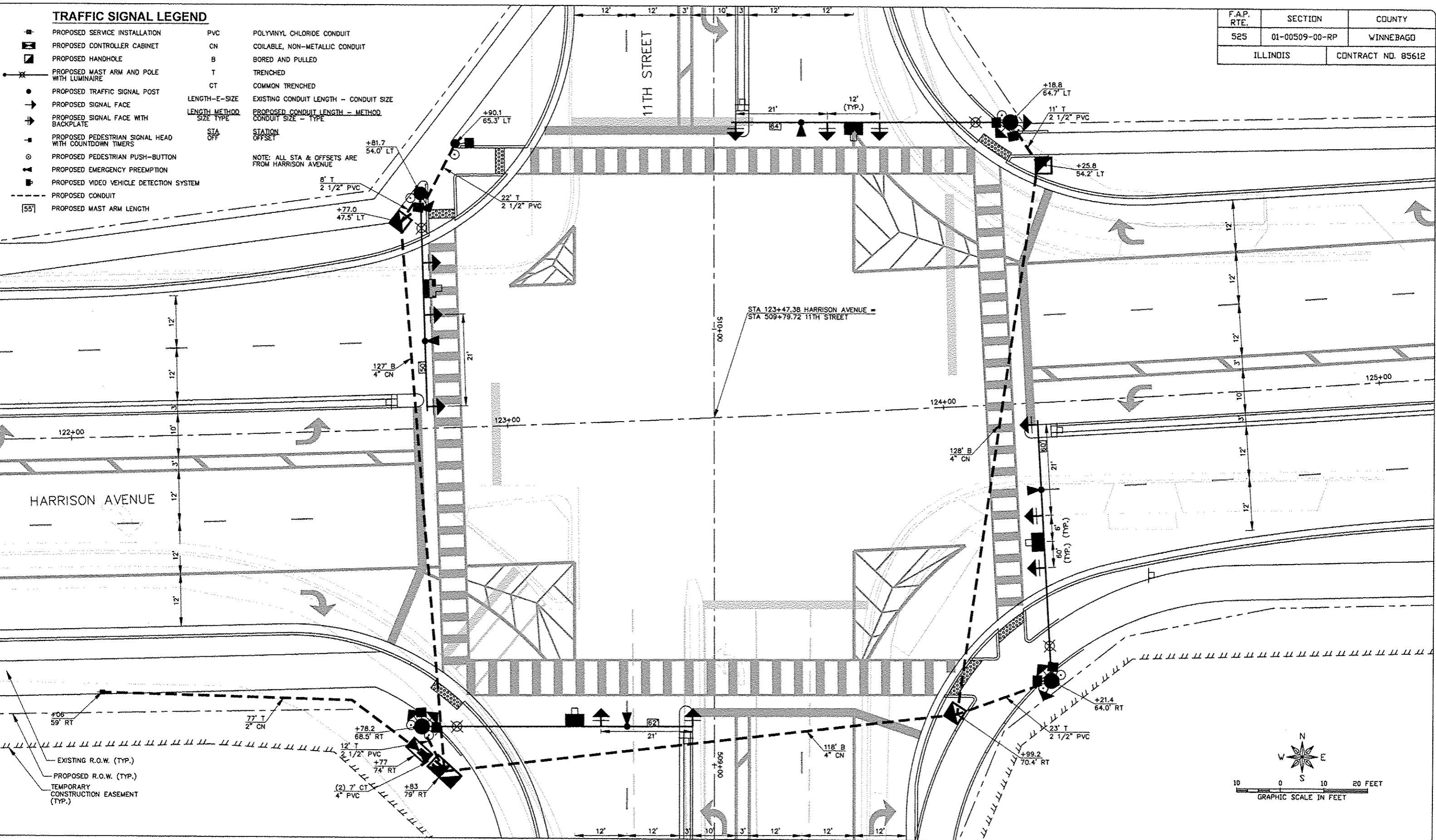

**FEHR GRAHAM**  
 ENGINEERING & ENVIRONMENTAL  
 ILLINOIS DESIGN FIRM NO. 194-003525  
 © 2014 FEHR GRAHAM

ILLINOIS  
 IOWA  
 WISCONSIN

**McClure**  
 Engineering Associates, Inc.  
 7282 Argus Drive, Rockford, Illinois 61107-5937  
 (815) 398-2332 FAX (815) 398-2498  
 Design Firm License: Illinois 194-000819  
 Copyright 2014 By McClure Engineering Associates, Inc.

PROJECT AND LOCATION:  
 HARRISON AVENUE RECONSTRUCTION  
 IL 251 AND FAP 0525  
 11TH ST. TO 20TH ST.

DRAWN BY: KRL  
 APPROVED BY: JWH  
 DATE: 6/12/2015  
 SCALE:

| REV. NO. | DESCRIPTION | DATE |
|----------|-------------|------|
|          |             |      |
|          |             |      |
|          |             |      |

DRAWING:  
 TRAFFIC SIGNAL PLAN - 11TH STREET

JOB NUMBER:  
 13-1070  
 SHEET NUMBER:  
 349 of 588

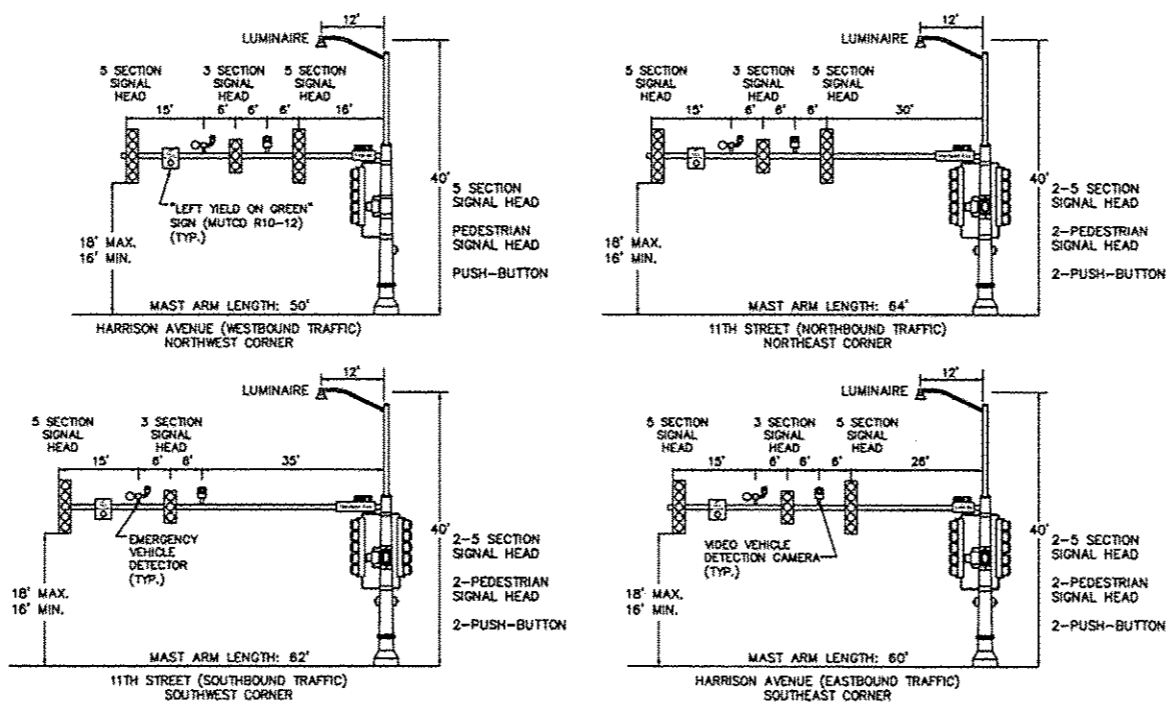
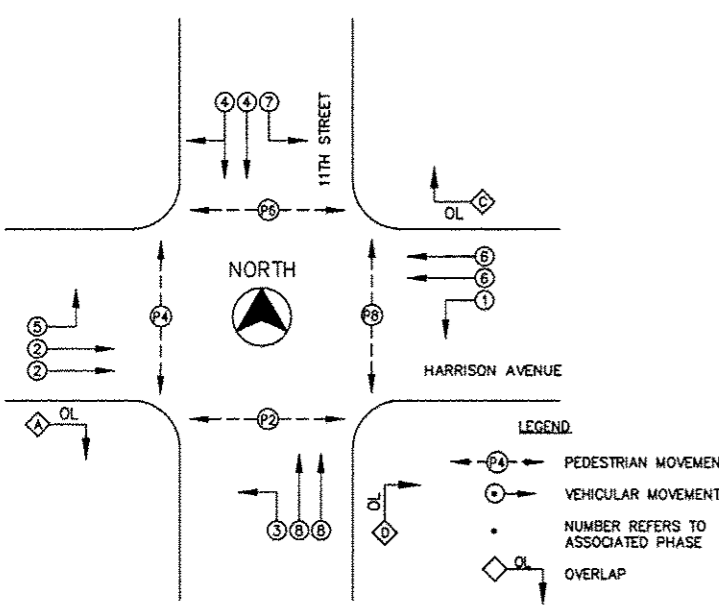

**SUMMARY OF QUANTITIES**

| SP. ITEM NO. | PAY ITEM  | UNIT  | QUANTITY |
|--------------|---|-------|----------|
| 72000100     | SIGN PANEL - TYPE 1   | SQ FT | 26       |
| 80500200     | SERVICE INSTALLATION, TYPE B  | EACH  | 1        |
| 81028360     | UNDERGROUND CONDUIT, PVC, 2 1/2" DIA.   | FOOT  | 76       |
| 81028390     | UNDERGROUND CONDUIT, PVC, 4" DIA.   | FOOT  | 14       |
| 81028750     | UNDERGROUND CONDUIT, COILABLE NONMETALLIC CONDUIT, 2" DIA.                                | FOOT  | 77       |
| 81028790     | UNDERGROUND CONDUIT, COILABLE NONMETALLIC CONDUIT, 4" DIA.                                | FOOT  | 373      |
| 81400100     | HANDHOLE  | EACH  | 3        |
| 81400300     | DOUBLE HANDHOLE   | EACH  | 1        |
| 81702110     | ELECTRIC CABLE IN CONDUIT, 600V (XLP-TYPE USE) 1/C NO. 10                                 | FOOT  | 1786     |
| 85100500     | PAINT NEW TRAFFIC SIGNAL POST   | EACH  | 1        |
| 85100801     | PAINT NEW COMBINATION MAST ARM AND POLE, 40 FOOT AND OVER                                 | EACH  | 4        |
| 85700200     | FULL-ACTUATED CONTROLLER AND TYPE IV CABINET  | EACH  | 1        |
| 87301215     | ELECTRIC CABLE IN CONDUIT, SIGNAL NO. 14 2C   | FOOT  | 2359     |
| 87301225     | ELECTRIC CABLE IN CONDUIT, SIGNAL NO. 14 3C   | FOOT  | 1468     |
| 87301245     | ELECTRIC CABLE IN CONDUIT, SIGNAL NO. 14 5C   | FOOT  | 923      |
| 87301255     | ELECTRIC CABLE IN CONDUIT, SIGNAL NO. 14 7C   | FOOT  | 3031     |
| 87301805     | ELECTRIC CABLE IN CONDUIT, SERVICE, NO. 6 2 C   | FOOT  | 96       |
| 87301900     | ELECTRIC CABLE IN CONDUIT, EQUIPMENT GROUNDING CONDUCTOR, NO. 6 1C                        | FOOT  | 582      |
| 87502440     | TRAFFIC SIGNAL POST, GALVANIZED STEEL 10 FT.  | EACH  | 1        |
| 87702980     | STEEL COMBINATION MAST ARM ASSEMBLY AND POLE 50 FT.                                       | EACH  | 1        |
| 87703030     | STEEL COMBINATION MAST ARM ASSEMBLY AND POLE 60 FT.                                       | EACH  | 1        |
| 87703040     | STEEL COMBINATION MAST ARM ASSEMBLY AND POLE 62 FT.                                       | EACH  | 1        |
| 87703050     | STEEL COMBINATION MAST ARM ASSEMBLY AND POLE 64 FT.                                       | EACH  | 1        |
| 87800100     | CONCRETE FOUNDATION, TYPE A   | FOOT  | 3.1      |
| 87800200     | CONCRETE FOUNDATION, TYPE D   | FOOT  | 3.5      |
| 87800415     | CONCRETE FOUNDATION, TYPE E 36-INCH DIAMETER  | FOOT  | 15       |
| 87800420     | CONCRETE FOUNDATION, TYPE E 42-INCH DIAMETER  | FOOT  | 63       |
| 88040090     | SIGNAL HEAD, POLYCARBONATE, LED, 1-FACE, 3-SECTION, MAST ARM MOUNTED                      | EACH  | 4        |
| 88040150     | SIGNAL HEAD, POLYCARBONATE, LED, 1-FACE, 5-SECTION, BRACKET MOUNTED                       | EACH  | 1        |
| 88040160     | SIGNAL HEAD, POLYCARBONATE, LED, 1-FACE, 5-SECTION, MAST ARM MOUNTED                      | EACH  | 7        |
| 88040290     | SIGNAL HEAD, POLYCARBONATE, LED, 2-FACE, 5-SECTION, BRACKET MOUNTED                       | EACH  | 3        |
| 88102825     | PEDESTRIAN SIGNAL HEAD, POLYCARBONATE, LED, 1-FACE, BRACKET MOUNTED WITH COUNT DOWN TIMER | EACH  | 2        |
| 88102845     | PEDESTRIAN SIGNAL HEAD, POLYCARBONATE, LED, 2-FACE, BRACKET MOUNTED WITH COUNT DOWN TIMER | EACH  | 3        |
| 88200310     | TRAFFIC SIGNAL BACKPLATE, LOUVERED, PLASTIC   | EACH  | 11       |
| 88800100     | PEDESTRIAN PUSH-BUTTON  | EACH  | 8        |
| X0324102     | EMERGENCY VEHICLE SIGNAL CONTROL SYSTEM   | EACH  | 1        |
| XX003167     | NAME SIGN, MAST ARM MOUNTED (INSTALL ONLY)  | EACH  | 8        |
| X8210675     | LUMINAIRE, METAL HALIDE HORIZONTAL MOUNT 400 WATT   | EACH  | 4        |
| Z0033072     | VIDEO VEHICLE DETECTION SYSTEM  | EACH  | 1        |

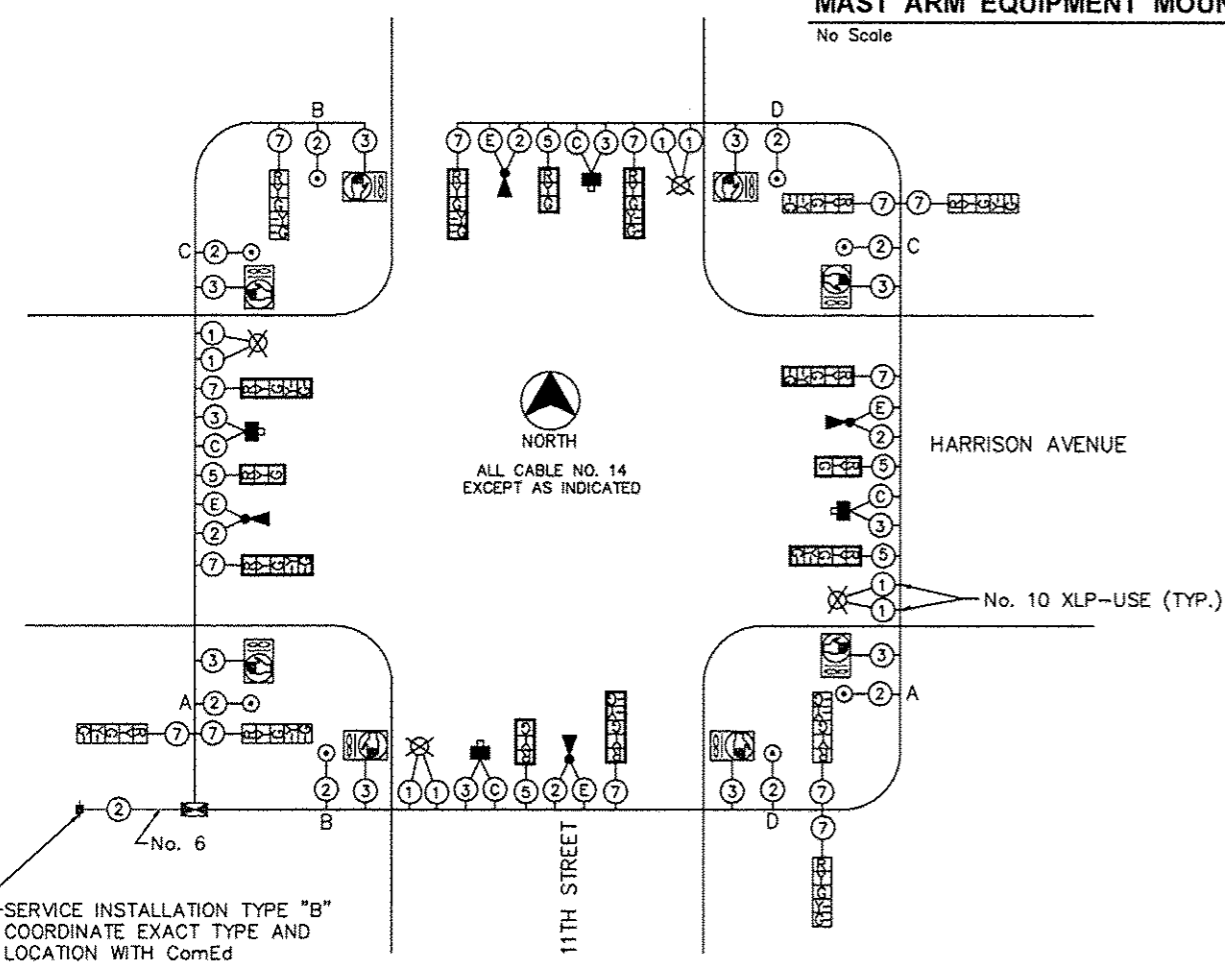

**CABLE PLAN LEGEND**

- SERVICE INSTALLATION
- ② CABLE WITH NO. OF CONDUCTORS
- ☐ SIGNAL HEAD WITH BACKPLATE (12" LENSES)
- ☐ SIGNAL HEAD WITHOUT BACKPLATE (12" LENSES)
- ☐ PEDESTRIAN SIGNAL HEAD
- ⊙ PEDESTRIAN PUSH-BUTTON
- ☐ CONTROLLER CABINET
- ☐ LUMINAIRE
- ☐ EMERGENCY VEHICLE SIGNAL CONTROL SYSTEM
- ⊙ EMERGENCY VEHICLE SIGNAL CONTROL SYSTEM CABLE (INCLUDED IN EMERGENCY VEHICLE SIGNAL CONTROL SYSTEM PAY ITEM)
- ☐ VIDEO VEHICLE DETECTION SYSTEM
- ⊙ VIDEO VEHICLE DETECTION CAMERA CABLE (INCLUDED IN VIDEO VEHICLE DETECTION SYSTEM PAY ITEM)

**CONTROLLER SPECIFIED:**  
FULL-ACTUATED CONTROLLER AND TYPE IV CABINET

**THE POSTED SPEED LIMIT ON:**  
HARRISON AVENUE IS 45 MPH  
11TH STREET IS 35 MPH

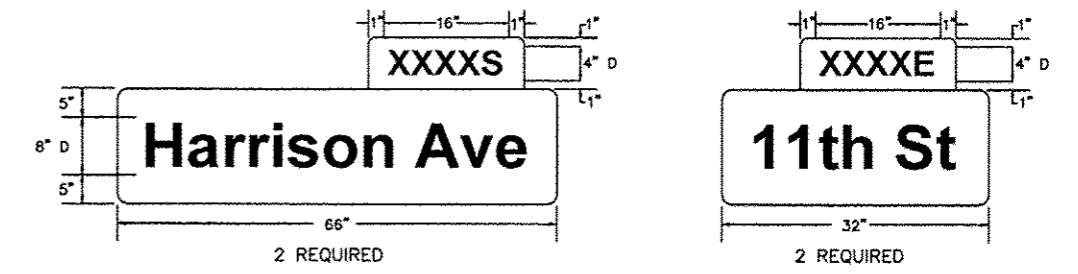

**GENERAL NOTES**

- ALL SIGNING, STRIPING, TRAFFIC SIGNALS, AND TRAFFIC CONTROL DEVICES DURING CONSTRUCTION SHALL CONFORM TO THE MANUAL ON UNIFORM TRAFFIC CONTROL DEVICES (M.U.T.C.D.) CURRENT EDITION.
- ALL NEW CONSTRUCTION SHALL CONFORM TO THE SPECIFICATIONS OF THE CITY OF ROCKFORD AND THE ILLINOIS DEPARTMENT OF TRANSPORTATION "STANDARD SPECIFICATIONS FOR ROAD AND BRIDGE CONSTRUCTION", ADOPTED JANUARY 1, 2012.
- ALL MAST ARMS SHALL HAVE A 40' LUMINAIRE MOUNTING HEIGHT. MATERIAL TYPES SHALL BE AS FOLLOWS: SIGNAL POLES SHALL BE GALVANIZED STEEL, MAST ARM ASSEMBLIES SHALL BE STEEL, SIGNAL HEADS AND BRACKET ARMS SHALL BE POLYCARBONATE, BRACKET MOUNTED OR MAST ARM MOUNTED. ALL TRAFFIC SIGNAL POST OR MAST ARMS ARE TO BE PAINTED IN ACCORDANCE WITH THE SPECIAL PROVISIONS AND CITY OF ROCKFORD SPECIFICATIONS.
- MAST ARM MOUNTED STREET NAME SIGNS SHALL BE CREATED AS SHOWN AND MOUNTED IN ACCORDANCE WITH THE ILLINOIS DEPARTMENT OF TRANSPORTATION STANDARDS AND SPECIFICATIONS AND AS DIRECTED BY THE CITY TRAFFIC ENGINEER. SIGNS SHALL BE SUPPLIED BY THE CITY OF ROCKFORD AND INSTALLED BY THE CONTRACTOR IN ACCORDANCE WITH THE MUTCD AND CITY REQUIREMENTS.
- WIRING FOR LUMINAIRE SHALL CONSIST OF TWO 600V (XLP-TYPE USE) 1/C NO. 10 WIRES FROM LUMINAIRE TO POLE HANDHOLE AND TWO 600V (XLP-TYPE USE) 1/C NO. 10 WIRES FROM THE POLE HANDHOLE TO CONTROLLER. IN THE CASE THAT THE LUMINAIRE USED IN CONSTRUCTION REQUIRES THE CONTROL WIRE TO CROSS THE BALLAST, THE 600V (XLP-TYPE USE) 1/C NO. 10, WHICH RUNS FROM THE LUMINAIRE TO THE POLE HANDHOLE, SHALL BE REPLACED WITH NO. 12 (THHN) 1/C PER MANUFACTURER'S SPECIFICATIONS. THE ELECTRIC CABLE IN CONDUIT, EQUIPMENT GROUNDING CONDUCTOR, NO. 6 1C SHALL RUN FROM FOUNDATION GROUND ROD TO ELECTRIC SERVICE GROUND AND SHALL INCLUDE A GREEN INSULATED JACKET.
- PEDESTRIAN SIGNAL HEADS SHALL HAVE A 10' MINIMUM MOUNTING HEIGHT. EACH PEDESTRIAN PUSH-BUTTON SHALL BE MOUNTED WITH A "PUSH BUTTON FOR GREEN" SIGN, M.U.T.C.D. R10-4 (9" X 12"). BUTTONS MUST BE LOCATED WITHIN 10-INCH HORIZONTAL REACH OF RAMP "TURNING SPACE" AND SHALL BE MOUNTED IN ACCORDANCE WITH SECTION 4E.08 OF THE M.U.T.C.D.
- THE UNIVERSAL GENERATOR TRANSFER SWITCH IS INCLUDED IN THE COST OF THE CONTROLLER CABINET.

| REVISIONS |             |      |
|-----------|-------------|------|
| REV. NO.  | DESCRIPTION | DATE |
|           |             |      |
|           |             |      |
|           |             |      |

**TRAFFIC SIGNAL LEGEND**

- PROPOSED SERVICE INSTALLATION
  - PROPOSED CONTROLLER CABINET
  - PROPOSED HANDHOLE
  - ⊗ PROPOSED MAST ARM AND POLE WITH LUMINAIRE
  - PROPOSED TRAFFIC SIGNAL POST
  - PROPOSED SIGNAL FACE
  - PROPOSED SIGNAL FACE WITH BACKPLATE
  - ⊕ PROPOSED PEDESTRIAN SIGNAL HEAD WITH COUNTDOWN TIMERS
  - ⊕ PROPOSED PEDESTRIAN PUSH-BUTTON
  - ⊕ PROPOSED EMERGENCY PREEMPTION
  - PROPOSED VIDEO VEHICLE DETECTION SYSTEM
  - - - PROPOSED CONDUIT
  - [55'] PROPOSED MAST ARM LENGTH
- |                         |  |
|-------------------------|--|
| PVC                     | POLYVINYL CHLORIDE CONDUIT                           |
| CN                      | COILABLE, NON-METALLIC CONDUIT                       |
| B                       | BORED AND PULLED                                     |
| T                       | TRENCHED   |
| CT                      | COMMON TRENCHED                                      |
| LENGTH-E-SIZE           | EXISTING CONDUIT LENGTH - CONDUIT SIZE               |
| LENGTH METHOD SIZE TYPE | PROPOSED CONDUIT LENGTH - METHOD CONDUIT SIZE - TYPE |
| STA                     | STATION  |
| OFF                     | OFFSET   |
- NOTE: ALL STA & OFFSETS ARE FROM HARRISON AVENUE

|             |                |                    |
|-------------|----------------|--------------------|
| F.A.P. RTE. | SECTION        | COUNTY             |
| 525         | 01-00509-00-RP | WINNEBAGO          |
| ILLINOIS    |                | CONTRACT NO. 85612 |

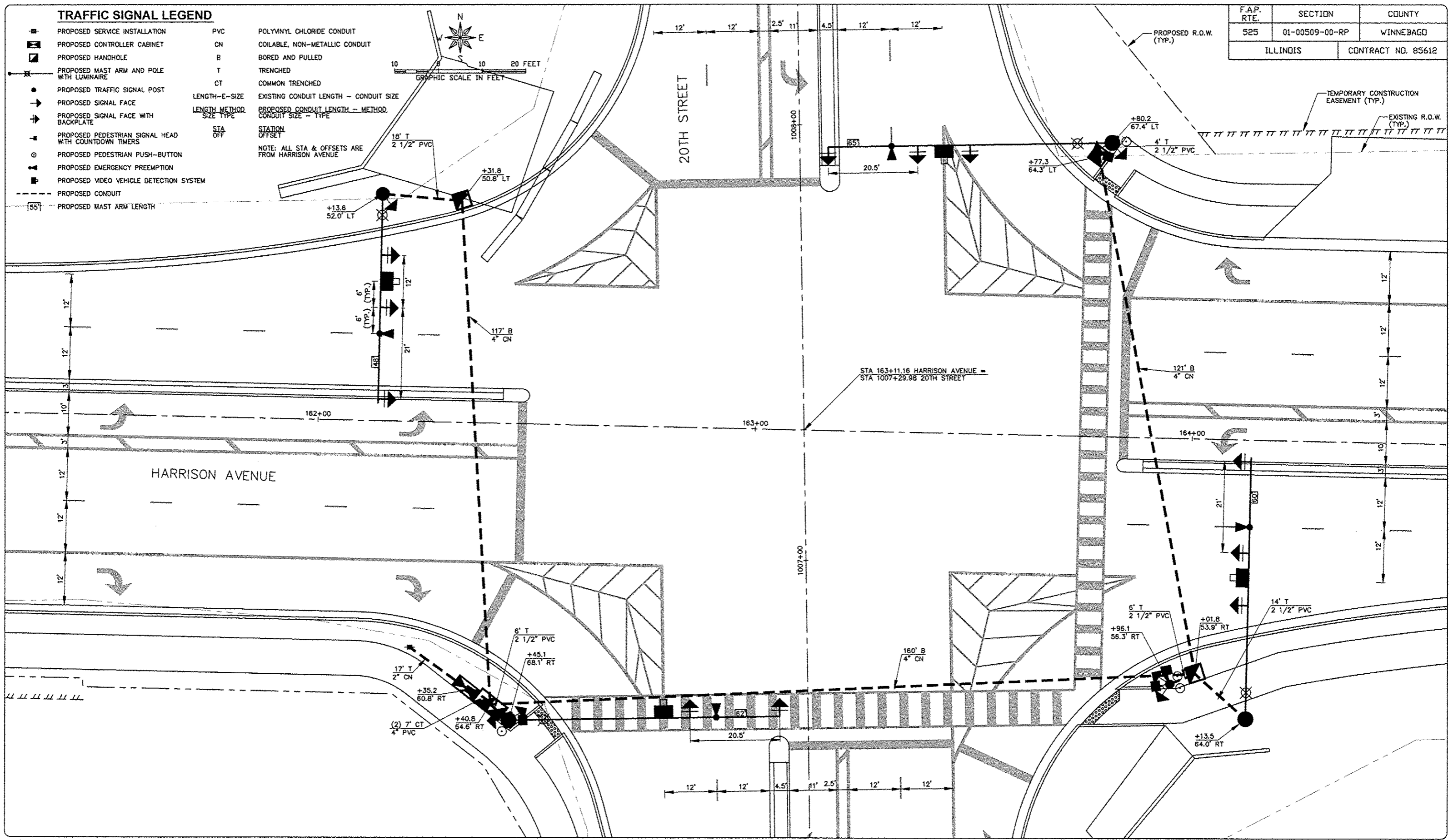

**FEHR GRAHAM**  
ENGINEERING & ENVIRONMENTAL  
ILLINOIS DESIGN FIRM NO. 184-003525  
© 2014 FEHR GRAHAM

ILLINOIS  
IOWA  
WISCONSIN

**McClure**  
Engineering Associates, Inc.  
7282 Argus Drive  
Rockford, Illinois 61107-6837  
(815) 398-2332 FAX (815) 308-2496  
Design Firm License: Illinois 184-000816  
Copyright 2014 By McClure Engineering Associates, Inc.

PROJECT AND LOCATION:  
HARRISON AVENUE RECONSTRUCTION  
IL 251 AND FAP 0525  
11TH ST. TO 20TH ST.

DRAWN BY: KRL  
APPROVED BY: JWH  
DATE: 6/12/2015  
SCALE:

| REV. NO. | DESCRIPTION | DATE |
|----------|-------------|------|
|          |             |      |
|          |             |      |
|          |             |      |

DRAWING:  
TRAFFIC SIGNAL PLAN-20TH STREET

JOB NUMBER:  
13-1070  
SHEET NUMBER:  
351 of 588

|             |                |                    |
|-------------|----------------|--------------------|
| F.A.P. RTE. | SECTION        | COUNTY             |
| 525         | 01-00509-00-RP | WINNEBAGO          |
| ILLINOIS    |                | CONTRACT NO. 85612 |

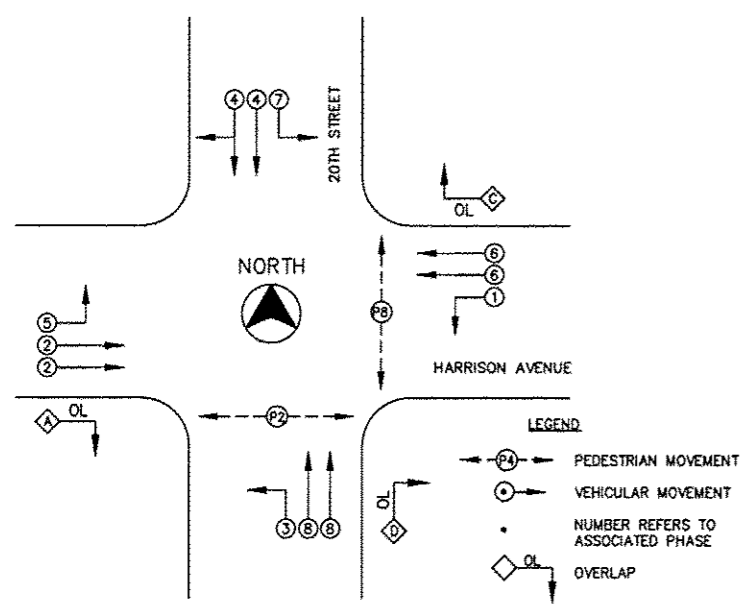

**PHASE DESIGNATION DIAGRAM**  
No Scale REFER TO IDOT STANDARD 857001

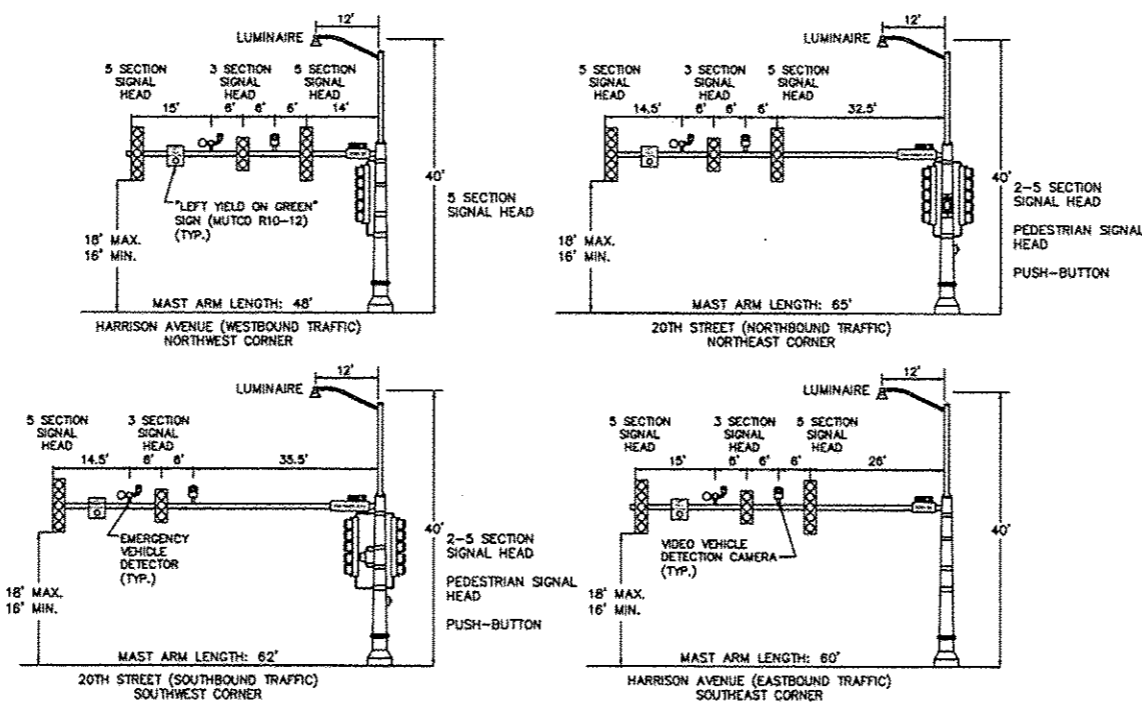

**MAST ARM EQUIPMENT MOUNTING DETAIL**  
No Scale

**SUMMARY OF QUANTITIES**

| SP. ITEM NO. | PAY ITEM  | UNIT  | QUANTITY |
|--------------|---|-------|----------|
| 72000100     | SIGN PANEL - TYPE 1   | SQ FT | 23       |
| 80500200     | SERVICE INSTALLATION, TYPE B  | EACH  | 1        |
| 81028360     | UNDERGROUND CONDUIT, PVC, 2 1/2" DIA.   | FOOT  | 48       |
| 81028390     | UNDERGROUND CONDUIT, PVC, 4" DIA.   | FOOT  | 14       |
| 81028750     | UNDERGROUND CONDUIT, COILABLE NONMETALLIC CONDUIT, 2" DIA.                                | FOOT  | 17       |
| 81028790     | UNDERGROUND CONDUIT, COILABLE NONMETALLIC CONDUIT, 4" DIA.                                | FOOT  | 398      |
| 81400100     | HANDHOLE  | EACH  | 3        |
| 81400300     | DOUBLE HANDHOLE   | EACH  | 1        |
| 81702110     | ELECTRIC CABLE IN CONDUIT, 600V (XLP-TYPE USE) 1/C NO. 10                                 | FOOT  | 1880     |
| 85100500     | PAINT NEW TRAFFIC SIGNAL POST   | EACH  | 1        |
| 85100901     | PAINT NEW COMBINATION MAST ARM AND POLE, 40 FOOT AND OVER                                 | EACH  | 4        |
| 85700200     | FULL-ACTUATED CONTROLLER AND TYPE IV CABINET  | EACH  | 1        |
| 87301215     | ELECTRIC CABLE IN CONDUIT, SIGNAL NO. 14 2C   | FOOT  | 1764     |
| 87301225     | ELECTRIC CABLE IN CONDUIT, SIGNAL NO. 14 3C   | FOOT  | 805      |
| 87301245     | ELECTRIC CABLE IN CONDUIT, SIGNAL NO. 14 5C   | FOOT  | 960      |
| 87301255     | ELECTRIC CABLE IN CONDUIT, SIGNAL NO. 14 7C   | FOOT  | 3241     |
| 87301805     | ELECTRIC CABLE IN CONDUIT, SERVICE, NO. 6 2 C   | FOOT  | 36       |
| 87301900     | ELECTRIC CABLE IN CONDUIT, EQUIPMENT GROUNDING CONDUCTOR, NO. 6 1C                        | FOOT  | 519      |
| 87502500     | TRAFFIC SIGNAL POST, GALVANIZED STEEL 16 FT.  | EACH  | 1        |
| 87702970     | STEEL COMBINATION MAST ARM ASSEMBLY AND POLE 48 FT.                                       | EACH  | 1        |
| 87703030     | STEEL COMBINATION MAST ARM ASSEMBLY AND POLE 60 FT.                                       | EACH  | 1        |
| 87703040     | STEEL COMBINATION MAST ARM ASSEMBLY AND POLE 62 FT.                                       | EACH  | 1        |
| 87703060     | STEEL COMBINATION MAST ARM ASSEMBLY AND POLE 65 FT.                                       | EACH  | 1        |
| 87800100     | CONCRETE FOUNDATION, TYPE A   | FOOT  | 3.1      |
| 87800200     | CONCRETE FOUNDATION, TYPE D   | FOOT  | 3.5      |
| 87800415     | CONCRETE FOUNDATION, TYPE E 36-INCH DIAMETER  | FOOT  | 13       |
| 87800420     | CONCRETE FOUNDATION, TYPE E 42-INCH DIAMETER  | FOOT  | 67       |
| 88040090     | SIGNAL HEAD, POLYCARBONATE, LED, 1-FACE, 3-SECTION, MAST ARM MOUNTED                      | EACH  | 4        |
| 88040150     | SIGNAL HEAD, POLYCARBONATE, LED, 1-FACE, 5-SECTION, BRACKET MOUNTED                       | EACH  | 1        |
| 88040160     | SIGNAL HEAD, POLYCARBONATE, LED, 1-FACE, 5-SECTION, MAST ARM MOUNTED                      | EACH  | 7        |
| 88040290     | SIGNAL HEAD, POLYCARBONATE, LED, 2-FACE, 5-SECTION, BRACKET MOUNTED                       | EACH  | 3        |
| 88102825     | PEDESTRIAN SIGNAL HEAD, POLYCARBONATE, LED, 1-FACE, BRACKET MOUNTED WITH COUNT DOWN TIMER | EACH  | 2        |
| 88102845     | PEDESTRIAN SIGNAL HEAD, POLYCARBONATE, LED, 2-FACE, BRACKET MOUNTED WITH COUNT DOWN TIMER | EACH  | 1        |
| 88200310     | TRAFFIC SIGNAL BACKPLATE, LOUVERED, PLASTIC   | EACH  | 11       |
| 88800100     | PEDESTRIAN PUSH-BUTTON  | EACH  | 4        |
| X0324102     | EMERGENCY VEHICLE SIGNAL CONTROL SYSTEM   | EACH  | 1        |
| XX003167     | NAME SIGN, MAST ARM MOUNTED (INSTALL ONLY)  | EACH  | 8        |
| X8210675     | LUMINAIRE, METAL HALIDE HORIZONTAL MOUNT 400 WATT   | EACH  | 4        |
| Z0033072     | VIDEO VEHICLE DETECTION SYSTEM  | EACH  | 1        |

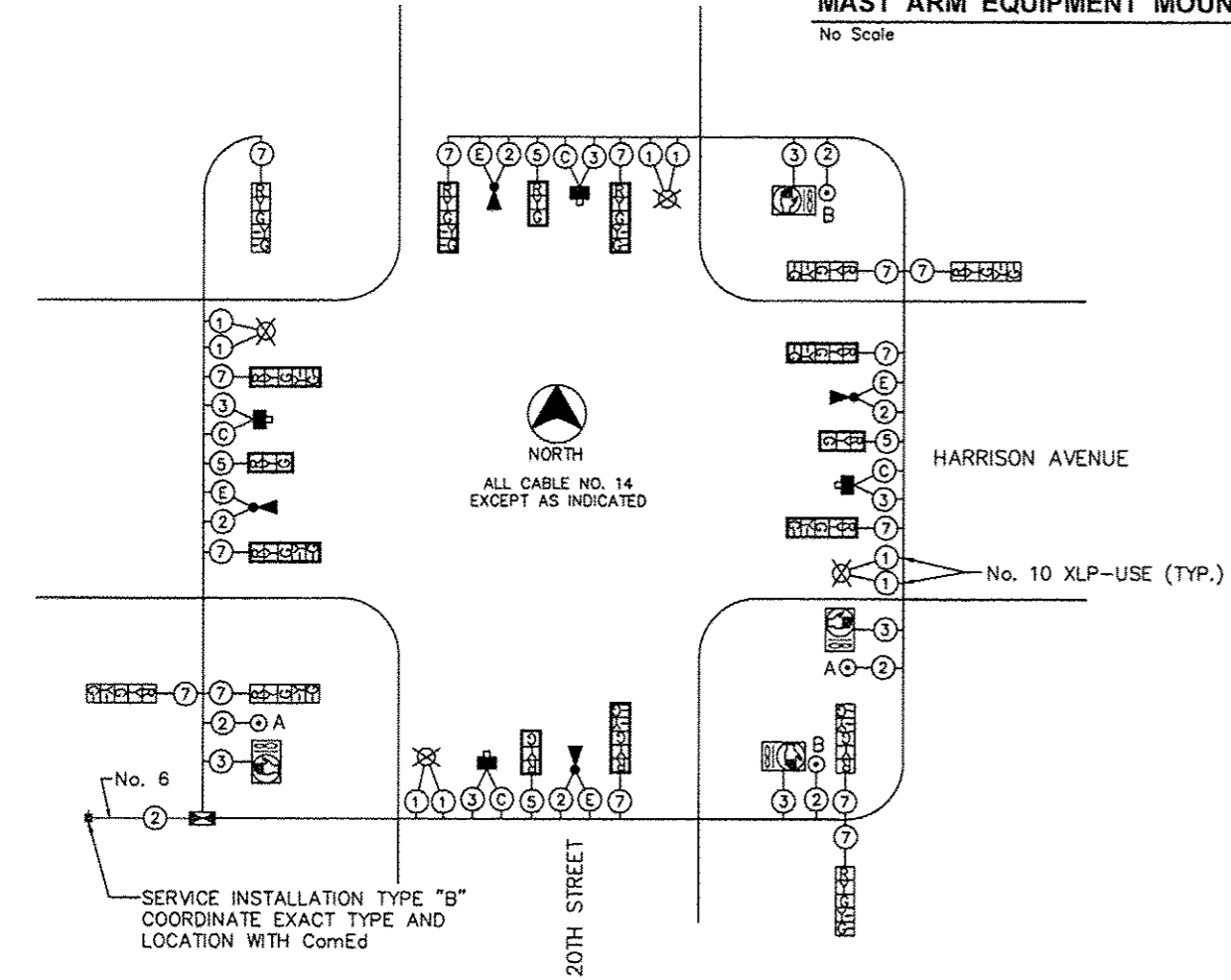

**CABLE PLAN**  
No Scale

**CABLE PLAN LEGEND**

- SERVICE INSTALLATION
- ⊗ CABLE WITH NO. OF CONDUCTORS
- ▭ SIGNAL HEAD WITH BACKPLATE (12" LENSES)
- ▭ SIGNAL HEAD WITHOUT BACKPLATE (12" LENSES)
- ⊗ PEDESTRIAN SIGNAL HEAD
- ⊙ PEDESTRIAN PUSH-BUTTON
- ▭ CONTROLLER CABINET
- ⊗ LUMINAIRE
- ▶ EMERGENCY VEHICLE SIGNAL CONTROL SYSTEM
- ⊗ EMERGENCY VEHICLE SIGNAL CONTROL SYSTEM CABLE (INCLUDED IN EMERGENCY VEHICLE SIGNAL CONTROL SYSTEM PAY ITEM)
- ▭ VIDEO VEHICLE DETECTION SYSTEM
- ⊗ VIDEO VEHICLE DETECTION CAMERA CABLE (INCLUDED IN VIDEO VEHICLE DETECTION SYSTEM PAY ITEM)

**CONTROLLER SPECIFIED:**  
FULL-ACTUATED CONTROLLER AND TYPE IV CABINET

**THE POSTED SPEED LIMIT ON:**  
HARRISON AVENUE IS 45 MPH  
20TH STREET IS 35 MPH

**PUSH-BUTTON NOTE:**  
BUTTONS "A" CALL PHASE 2  
BUTTONS "B" CALL PHASE 8

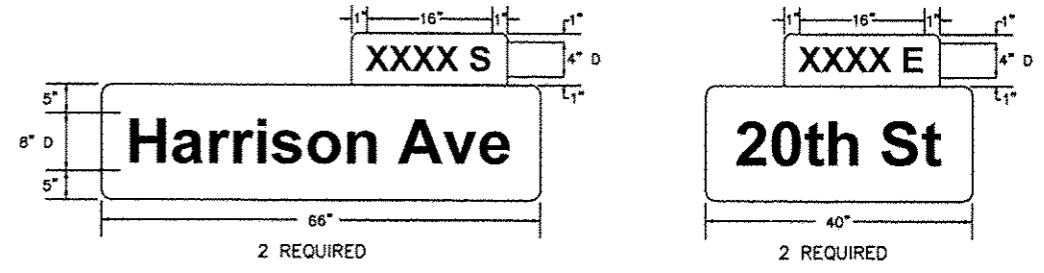

**MAST ARM MOUNTED STREET NAME SIGNS**  
NO SCALE REFER TO IDOT STANDARD 720016

**GENERAL NOTES**

- ALL SIGNING, STRIPING, TRAFFIC SIGNALS, AND TRAFFIC CONTROL DEVICES DURING CONSTRUCTION SHALL CONFORM TO THE MANUAL ON UNIFORM TRAFFIC CONTROL DEVICES (M.U.T.C.D.) CURRENT EDITION.
- ALL NEW CONSTRUCTION SHALL CONFORM TO THE SPECIFICATIONS OF THE CITY OF ROCKFORD AND THE ILLINOIS DEPARTMENT OF TRANSPORTATION "STANDARD SPECIFICATIONS FOR ROAD AND BRIDGE CONSTRUCTION", ADOPTED JANUARY 1, 2012.
- ALL MAST ARMS SHALL HAVE A 40' LUMINAIRE MOUNTING HEIGHT. MATERIAL TYPES SHALL BE AS FOLLOWS: SIGNAL POLES SHALL BE GALVANIZED STEEL, MAST ARM ASSEMBLIES SHALL BE STEEL, SIGNAL HEADS AND BRACKET ARMS SHALL BE POLYCARBONATE, BRACKET MOUNTED OR MAST ARM MOUNTED. ALL TRAFFIC SIGNAL POST OR MAST ARMS ARE TO BE PAINTED IN ACCORDANCE WITH THE SPECIAL PROVISIONS AND CITY OF ROCKFORD SPECIFICATIONS.
- MAST ARM MOUNTED STREET NAME SIGNS SHALL BE CREATED AS SHOWN AND MOUNTED IN ACCORDANCE WITH THE ILLINOIS DEPARTMENT OF TRANSPORTATION STANDARDS AND SPECIFICATIONS AND AS DIRECTED BY THE CITY TRAFFIC ENGINEER. SIGNS SHALL BE SUPPLIED BY THE CITY OF ROCKFORD AND INSTALLED BY THE CONTRACTOR IN ACCORDANCE WITH THE MUTCD AND CITY REQUIREMENTS.
- WIRING FOR LUMINAIRE SHALL CONSIST OF TWO 600V (XLP-TYPE USE) 1/C NO. 10 WIRES FROM LUMINAIRE TO POLE HANDHOLE AND TWO 600V (XLP-TYPE USE) 1/C NO. 10 WIRES FROM THE POLE HANDHOLE TO CONTROLLER. IN THE CASE THAT THE LUMINAIRE USED IN CONSTRUCTION REQUIRES THE CONTROL WIRE TO CROSS THE BALLAST, THE 600V (XLP-TYPE USE) 1/C NO. 10, WHICH RUNS FROM THE LUMINAIRE TO THE POLE HANDHOLE, SHALL BE REPLACED WITH NO. 12 (THHN) 1/C PER MANUFACTURER'S SPECIFICATIONS. THE ELECTRIC CABLE IN CONDUIT, EQUIPMENT GROUNDING CONDUCTOR, NO. 6 1C SHALL RUN FROM FOUNDATION GROUND ROD TO ELECTRIC SERVICE GROUND AND SHALL INCLUDE A GREEN INSULATED JACKET.
- PEDESTRIAN SIGNAL HEADS SHALL HAVE A 10' MINIMUM MOUNTING HEIGHT. EACH PEDESTRIAN PUSH-BUTTON SHALL BE MOUNTED WITH A "PUSH BUTTON FOR GREEN" SIGN, M.U.T.C.D. R10-4 (9" X 12"). BUTTONS MUST BE LOCATED WITHIN 10-INCH HORIZONTAL REACH OF RAMP "TURNING SPACE" AND SHALL BE MOUNTED IN ACCORDANCE WITH SECTION 4E.08 OF THE M.U.T.C.D.
- THE UNIVERSAL GENERATOR TRANSFER SWITCH IS INCLUDED IN THE COST OF THE CONTROLLER CABINET.

| REVISIONS |             |      |
|-----------|-------------|------|
| REV. NO.  | DESCRIPTION | DATE |
|           |             |      |
|           |             |      |
|           |             |      |

SCHEDULE OF QUANTITIES -- BID TYPE 1

ROADWAY LIGHTING SUMMARY OF QUANTITIES

| ITEM NUMBER | SP | PAY ITEM NUMBER | DESCRIPTION  | UNIT | QUANTITIES |
|-------------|----|-----------------|--|------|------------|
| 1           |    | 80400100        | ELECTRIC SERVICE INSTALLATION  | EACH | 3          |
| 2           |    | 81028220        | UNDERGROUND CONDUIT, GALVANIZED STEEL, 3" DIA.                         | FOOT | 1928       |
| 3           |    | 81028750        | UNDERGROUND CONDUIT, COILABLE NONMETALIC CONDUIT, 2" Dia.              | FOOT | 6318       |
| 4           |    | 81300320        | JUNCTION BOX, STAINLESS STEEL, ATTACHED TO STRUCTURE, 12" x 6"         | EACH | 4          |
| 5           | *  | 81400730        | HANDHOLE, COMPOSITE CONCRETE   | EACH | 24         |
| 6           |    | 81603037        | UNIT DUCT, 600V, 2-1C NO. 6, 1/C NO. 6 GROUND, (XLP TYPE USE), 2" DIA. | FOOT | 14766      |
| 7           |    | 82600360        | LIGHTING CONTROLLER, BASE MOUNTED, 480 VOLT, 100                       | EACH | 3          |
| 8           | *  | 83008200        | LIGHT POLE, ALUMINUM 40 FT., ** 6 FT. MAST                             | EACH | 78         |
| 9           | *  | 83008300        | LIGHT POLE, 40 FT., ** 8 FT. MAST                                      | EACH | 7          |
| 10          | *  | 83008400        | LIGHT POLE, 40 FT., ** 10 FT. MAST ARM                                 | EACH | 7          |
| 11          | *  | 83008500        | LIGHT POLE, 40 FT. M.H., 12 FT. MAST ARM                               | EACH | 1          |
| 12          |    | 83600300        | LIGHT POLE FOUNDATION, 24" DIAMETER                                    | FOOT | 552        |
| 13          |    | 83800566        | BREAKAWAY DEVICE, COUPLING, WITH ALUMINUM SKIRT                        | EACH | 372        |
| 14          | *  | X8210675        | LUMINAIRE, METAL HALIDE HORIZONTAL MOUNT 400 WATT                      | EACH | 93         |
| 15          | *  | 87300901        | ELECTRIC CABLE IN CONDUIT, TRACER, NO. 12 1C                           | FOOT | 6403       |

GENERAL NOTES

ROADWAY LIGHTING NOTES:

FORTY-EIGHT (48) HOURS PRIOR TO THE REMOVAL OF ALL EXISTING LIGHTING POLES AND APPURTENANCES, THE CONTRACTOR SHALL CONTACT THE ENGINEER AT 1-815-987-5535. ALL EXISTING LIGHT POLES AND APPURTENANCES SHALL BE REMOVED AND REMAIN THE PROPERTY OF THE CITY OF ROCKFORD, 500 SOUTH INDEPENDENCE AVENUE ROCKFORD, ILLINOIS 61102

1. PRIOR TO THE INSTALLATION OF THE NEW CABLES, UNDERGROUND CONDUITS, CONCRETE ENCASED CONDUITS, UNIT DUCTS, HANDHOLES, JUNCTION BOXES, LIGHT POLE FOUNDATIONS, CONTROLLER FOUNDATIONS AND APPURTENANCES, THE CONTRACTOR SHALL DETERMINE THE EXACT LOCATION OF EXISTING CONDUITS, CABLES AND UNDERGROUND UTILITIES. THE CONTRACTOR SHALL CALL J.U.L.I.E. TO AID IN THIS TASK.

2. THE CONTRACTOR SHALL VERIFY ALL OF THE DATA SHOWN ON THE CONTRACT PLANS AND REFERENCE DRAWINGS, WHICH WOULD AFFECT HIS WORK UNDER THIS CONTRACT.

3. ALL NEW CABLES, CONDUITS, HANDHOLES, JUNCTION BOXES AND APPURTENANCES ARE ILLUSTRATED DIAGRAMMATICALLY. PROPOSED ROUTING OF THE UNDERGROUND CONDUITS, AS SHOWN IN THE PLANS, IS FOR INFORMATION ONLY. CONTRACTOR SHALL VERIFY THE ACTUAL ROUTING LOCATION IN THE FIELD WITH THE APPROVAL OF THE ENGINEER.

4. ALL SPLICES SHALL BE HEAT SHRINK AND WATERPROOF AND INSTALLED INSIDE LIGHT POLE BASES OR JUNCTION BOXES. NO DIRECT BURIED SPLICES SHALL BE ALLOWED.

5. WHERE MULTIPLE CABLE DUCTS OR UNDERGROUND CONDUITS ADJACENT TO EACH OTHER ARE INSTALLED IN A COMMON TRENCH, TRENCH AND BACKFILL SHALL BE CONTINUOUS BETWEEN EACH CABLE DUCT OR UNDERGROUND CONDUIT FOR THE LENGTH OF THE COMMON TRENCH.

GENERAL NOTES

ROADWAY LIGHTING NOTES:

7. THE ELECTRICAL MATERIAL SHALL BE NEW AND OF THE TYPE AND KINDS APPROVED BY THE FOLLOWING ORGANIZATIONS:

NATIONAL ELECTRICAL MANUFACTURERS ASSOCIATION  
 INSTITUTE OF ELECTRICAL AND ELECTRONIC ENGINEERS  
 ILLUMINATION ENGINEERING SOCIETY OF NORTH AMERICA  
 AMERICAN ASSOCIATION OF STATE HIGHWAY AND TRANSPORTATION OFFICIALS  
 U.S. DEPARTMENT OF TRANSPORTATION UNDERWRITERS LABORATORIES AMERICAN STANDARD INSTITUTE  
 INSULATED POWER CABLE ENGINEERS ASSOCIATION

8. UNDERGROUND CONDUITS AND CABLE DUCTS SHALL BE POSITIONED IN THE FIELD TO AVOID CONFLICTS WITH UNDERDRAINS AND OTHER UTILITIES.

9. LUMINAIRES MUST BE INSTALLED ON LIGHT STANDARDS WITHIN A MAXIMUM OF 48 HOURS AFTER LIGHT STANDARD IS ERECTED.

10. PROPOSED UTILITY POLES SHALL BE INSTALLED BY COMMONWEALTH EDISON CO. CONTRACTOR SHALL INSTALL UNDERGROUND CONDUITS, GROUNDING, DISCONNECT SWITCH, AND ANY SECONDARY CONDUCTORS TO THE UTILITY POLE. COORDINATE ALL WORK WITH COMMONWEALTH EDISON CO. REFER TO LIGHTING CONTROLLER DETAIL.

11. THE CONTRACTOR SHALL PREPARE A SCHEDULE WHEN THE PROJECT COMMENCES, WHICH ESTABLISHES THE DATE WHEN ELECTRICAL SERVICES ARE REQUIRED. THIS SCHEDULE SHALL BE FORWARDED IN WRITING TO COMMONWEALTH EDISON CO. SUBSEQUENT UPDATING TO THE SCHEDULE SHALL ALSO BE FORWARDED TO COMMONWEALTH EDISON CO. AS CHANGES OCCUR A MINIMUM OF FIVE (5) DAYS BEFORE ELECTRICAL SERVICES ARE REQUIRED. THE CONTRACTOR SHALL NOTIFY COMMONWEALTH EDISON BY PHONE AND IN WRITING TO CONFIRM THE REQUIREMENT.

12. FORTY-EIGHT (48) HOURS PRIOR TO EXCAVATION FOR PROPOSED ROADWAY LIGHTING FOUNDATIONS, THE CONTRACTOR SHALL NOTIFY THE ENGINEER AND THE CITY OF ROCKFORD AFTER FIELD STAKING HAS OCCURRED TO VERIFY AND APPROVE ALL FOUNDATION LOCATIONS.

13. DEPENDENT ON THE LIGHTING FOUNDATION LOCATIONS, MAST ARM LENGTHS 6', 8', 10' OR 12' WILL BE DETERMINED BY THE ENGINEER AND CITY OF ROCKFORD. ADDITIONAL MAST ARMS OF VARYING LENGTH OF 6', 8', 10' AND 12' MAY NEED TO BE ORDERED DEPENDING ON THE FIELD FINDINGS. NO LIGHT POLES SHALL BE INSTALLED WITHOUT APPROVAL OF THE ENGINEER.

| F.A.P. SITE | SECTION        | COUNTY             |
|-------------|----------------|--------------------|
| 525         | 01-00509-00-RP | WINNEBAGO          |
| ILLINOIS    |                | CONTRACT NO. 85612 |

**FEHR GRAHAM**  
 ENGINEERING & ENVIRONMENTAL  
 ILLINOIS DESIGN FIRM NO. 184-003525  
 © 2013 FEHR GRAHAM

ILLINOIS  
 IOWA  
 WISCONSIN

OWNER/DEVELOPER:  
**Legacy Designs, Inc.**  
 8118 Mulford Village Drive  
 ROCKFORD, ILLINOIS 61107  
 Professional Design Firm No. 184-000483  
 815-984-4708 Phone 815-984-4710 Fax  
 e-mail: legacy@legacydesigns.net  
 www.legacydesigns.net

PROJECT AND LOCATION:  
**HARRISON AVENUE RECONSTRUCTION**  
**IL 251 AND FAP 0525**  
**11TH ST TO 20TH ST**

DRAWN BY: LDI  
 APPROVED BY: R.A.L.  
 DATE: 06/12/15  
 SCALE:

| REVISIONS |             |      |
|-----------|-------------|------|
| REV. NO.  | DESCRIPTION | DATE |
|           |             |      |
|           |             |      |
|           |             |      |

DRAWING:  
**LIGHTING NOTES**

JOB NUMBER:  
**13-1070**  
 SHEET NUMBER:  
**353 of 588**

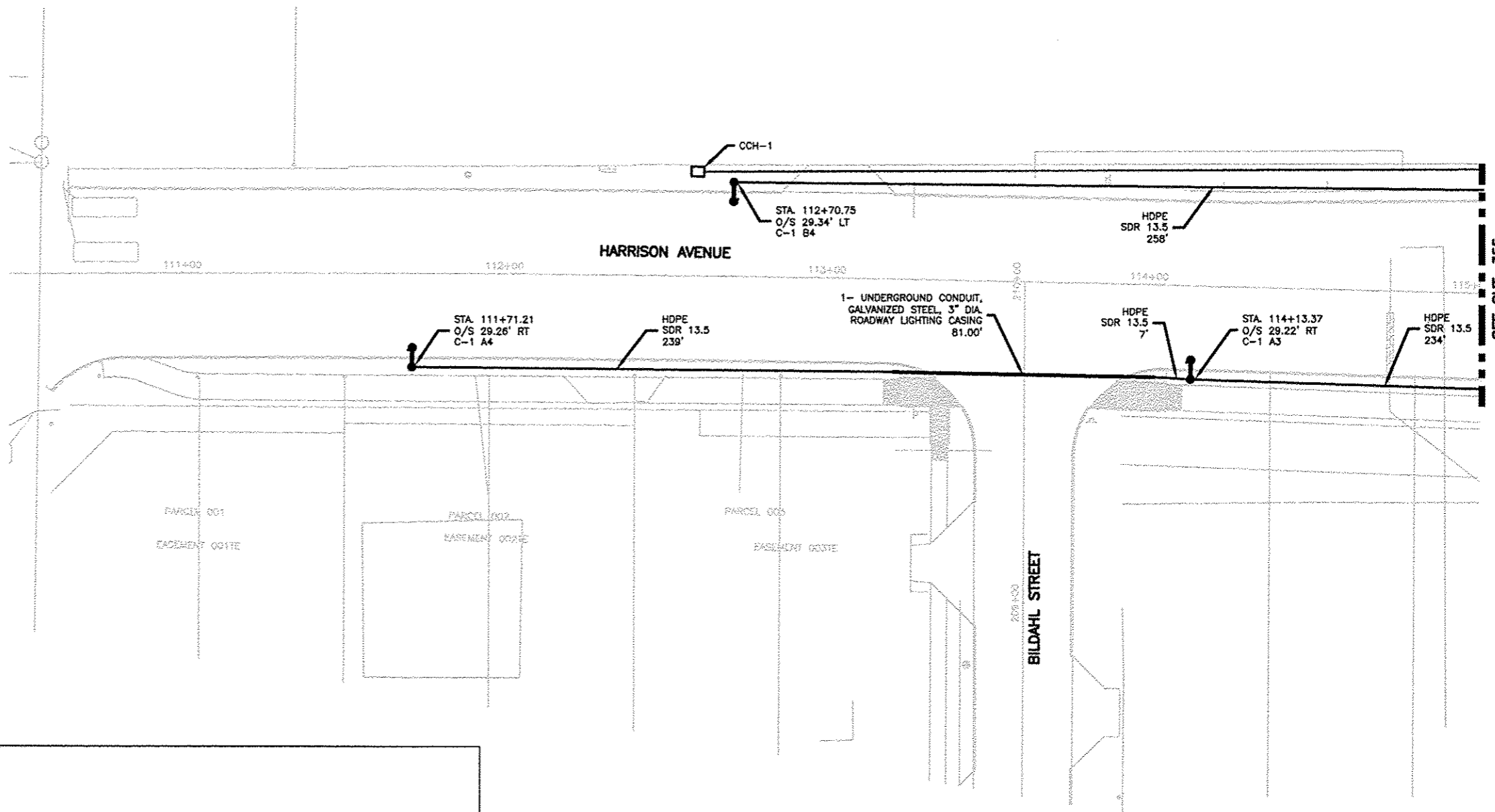

SEE SHT. 355

**LEGEND**

- EXISTING ROADWAY LIGHTPOLE AND LUMINAIRE TO BE REMOVED, SALVAGE
- PROPOSED DECORATIVE LIGHT POLE AND LUMINAIRE ALUMINUM, 40 FT. MOUNTING HEIGHT PULSE START METAL HALIDE, HORIZONTAL MOUNT 400 WATT 6'-0" ARM UNLESS NOTED
- HH = PROPOSED HANDHOLE PER IDOT STD 814001
- CCH = PROPOSED HANDHOLE, COMPOSITE CONCRETE TYPE AS INDICATED
- PROPOSED JUNCTION BOX
- PROPOSED UTILITY POLE (BY OTHERS)
- PROPOSED LIGHTING CONTROLLER, 100 AMP, 480V
- PROPOSED CONDUIT ATTACHED TO STRUCTURE, SIZE AND CONDUCTORS AS INDICATED
- PROPOSED UNDERGROUND CONDUIT, GALVANIZED STEEL, BORED AND PULLED SIZE AND CONDUCTORS AS INDICATED
- PROPOSED HDPE, 600V, 2-1/C NO. 6, 1/C NO. 6 GROUND, (XLP-TYPE USE), 2" DIA. POLYETHYLENE
- PROPOSED UNDERGROUND CONDUIT, GALVANIZED STEEL, SIZE AND CONDUCTORS AS INDICATED
- FO— PROPOSED UNDERGROUND CONDUIT, COILABLE NONMETALLIC, 2" DIA. WITH PULL STRING AND 1-1/C NO. 12 TRACER CABLE.

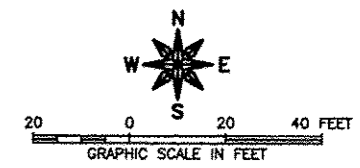

**FEHR GRAHAM**  
ENGINEERING & ENVIRONMENTAL  
ILLINOIS DESIGN FIRM NO. 184-003525  
© 2013 FEHR GRAHAM

ILLINOIS  
IOWA  
WISCONSIN

OWNER/DEVELOPER:  
**Legacy Designs, Inc.**  
6118 Madison Village Drive  
Rockford, IL 61107  
Professional Design Firm No. 104-003483  
815-399-4700 Phone 815-399-4710 Fax  
www.lid.com www.LegacyDesigns.com

PROJECT AND LOCATION:  
**HARRISON AVENUE RECONSTRUCTION  
IL 251 AND FAP 0525  
11TH ST TO 20TH ST**

DRAWN BY: LDI  
APPROVED BY: R.A.L.  
DATE: 06/12/15  
SCALE: TRUE 1/2

| REVISIONS |             |      |
|-----------|-------------|------|
| REV. NO.  | DESCRIPTION | DATE |
|           |             |      |
|           |             |      |
|           |             |      |

DRAWING:  
**PROPOSED LIGHTING PLAN  
HARRISON AVENUE AND SIDE STREETS**

JOB NUMBER:  
**13-1070**

SHEET NUMBER:  
**354 of 588**

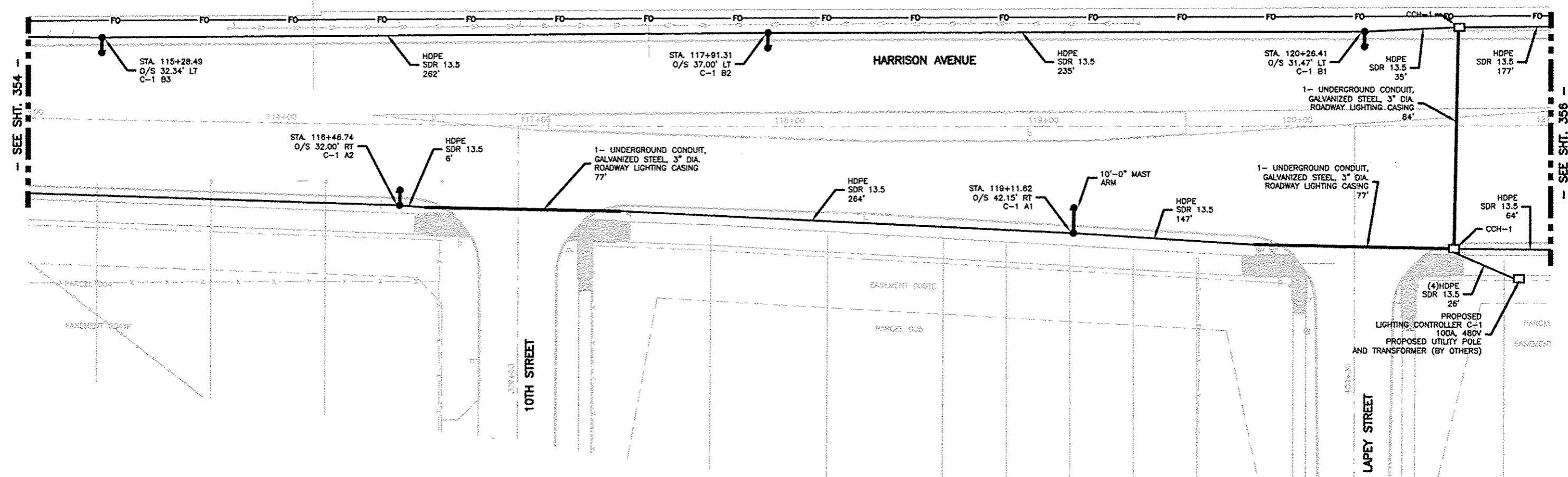

| LEGEND |  |
|--------|--|
|        | EXISTING ROADWAY LIGHTPOLE AND LUMINAIRE TO BE REMOVED, SALVAGE  |
|        | PROPOSED DECORATIVE LIGHT POLE AND LUMINAIRE ALUMINUM, 40 FT. MOUNTING HEIGHT PULSE START METAL HALIDE, HORIZONTAL MOUNT 400 WATT 6'-0" ARM UNLESS NOTED |
|        | HH = PROPOSED HANDHOLE PER IDOT STD 814001   |
|        | CCH = PROPOSED HANDHOLE, COMPOSITE CONCRETE TYPE AS INDICATED  |
|        | PROPOSED JUNCTION BOX  |
|        | PROPOSED UTILITY POLE (BY OTHERS)  |
|        | PROPOSED LIGHTING CONTROLLER, 100 AMP, 480V  |
|        | PROPOSED CONDUIT ATTACHED TO STRUCTURE, SIZE AND CONDUCTORS AS INDICATED   |
|        | PROPOSED UNDERGROUND CONDUIT, GALVANIZED STEEL, BORED AND PULLED SIZE AND CONDUCTORS AS INDICATED  |
|        | PROPOSED HDPE, 600V, 2-1/C NO. 6, 1/C NO. 6 GROUND, (XLP-TYPE USE), 2" DIA. POLYETHYLENE   |
|        | PROPOSED UNDERGROUND CONDUIT, GALVANIZED STEEL SIZE AND CONDUCTORS AS INDICATED  |
|        | FO = PROPOSED UNDERGROUND CONDUIT, COILABLE NONMETALIC, 2" DIA. WITH PULL STRING AND 1-1/C NO. 12 TRACER CABLE.  |

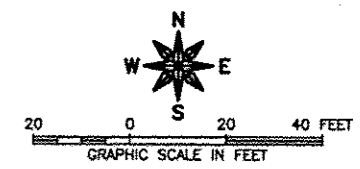

**FEHR GRAHAM**  
ENGINEERING & ENVIRONMENTAL  
ILLINOIS DESIGN FIRM NO. 134-003525  
© 2013 FEHR GRAHAM

ILLINOIS  
IOWA  
WISCONSIN

OWNER/DEVELOPER:  
**Legacy Designs, Inc.**  
6118 Midford Village Drive  
ROCKFORD, ILLINOIS 61107  
Professional Design Firm No. 184-003483  
815-399-4708 Fax No. 815-399-4710 Fax  
e-mail: legacydesigns@legacydesigns.com  
www.legacydesigns.com

PROJECT AND LOCATION:  
**HARRISON AVENUE RECONSTRUCTION  
IL 251 AND FAP 0525  
11TH ST TO 20TH ST**

DRAWN BY: LDI  
APPROVED BY: R.A.L.  
DATE: 08/12/15  
SCALE: TRUE 1/2

| REVISIONS |             |      |
|-----------|-------------|------|
| REV. NO.  | DESCRIPTION | DATE |
|           |             |      |
|           |             |      |
|           |             |      |

DRAWING:  
**PROPOSED LIGHTING PLAN  
HARRISON AVENUE AND SIDE STREETS**

JOB NUMBER:  
**13-1070**

SHEET NUMBER:  
**355 of 588**

**LEGEND**

- EXISTING ROADWAY LIGHTPOLE AND LUMINAIRE TO BE REMOVED, SALVAGE
- PROPOSED DECORATIVE LIGHT POLE AND LUMINAIRE ALUMINUM, 40 FT. MOUNTING HEIGHT PULSE START METAL HALIDE, HORIZONTAL MOUNT 400 WATT 6'-0" ARM UNLESS NOTED
- HH = PROPOSED HANDHOLE PER IDOT STD 814001  
CCH = PROPOSED HANDHOLE, COMPOSITE CONCRETE TYPE AS INDICATED
- ▣ PROPOSED JUNCTION BOX
- PROPOSED UTILITY POLE (BY OTHERS)
- PROPOSED LIGHTING CONTROLLER, 100 AMP, 480V

**LEGEND**

- PROPOSED CONDUIT ATTACHED TO STRUCTURE, SIZE AND CONDUCTORS AS INDICATED
- PROPOSED UNDERGROUND CONDUIT, GALVANIZED STEEL, BORED AND PULLED SIZE AND CONDUCTORS AS INDICATED
- PROPOSED HDPE, 600V, 2-1/2" NO. 6, 1/C NO. 6 GROUND, (XLP-TYPE USE), 2" DIA. POLYETHYLENE
- PROPOSED UNDERGROUND CONDUIT, GALVANIZED STEEL, SIZE AND CONDUCTORS AS INDICATED
- FO— PROPOSED UNDERGROUND CONDUIT, COILABLE NONMETALLIC, 2" DIA. WITH PULL STRING AND 1-1/2" NO. 12 TRACER CABLE.

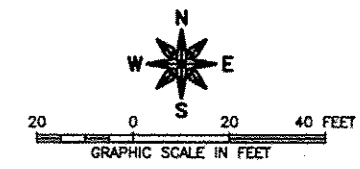
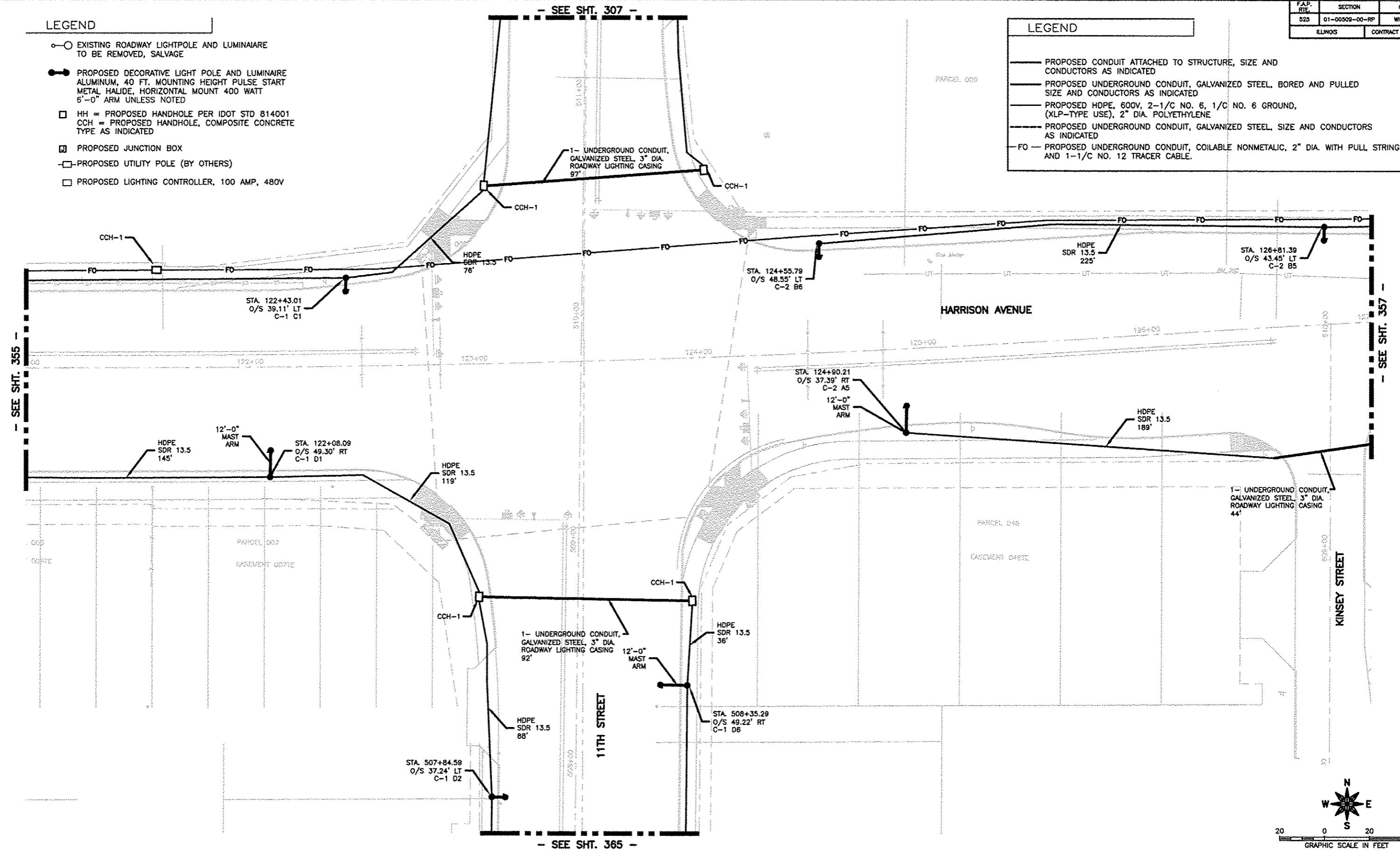

**FEHR GRAHAM**  
ENGINEERING & ENVIRONMENTAL  
ILLINOIS DESIGN FIRM NO. 184-003525  
© 2013 FEHR GRAHAM

ILLINOIS  
IOWA  
WISCONSIN

OWNER/DEVELOPER:  
**Legacy Designs, Inc.**  
6116 Mallard Village Drive  
SCOTSDALE, ILLINOIS 61107  
Professional Design Firm No. 184-003483  
615-484-0708 Phone 615-484-0710 Fax  
www.legacydesigns.com

PROJECT AND LOCATION:  
**HARRISON AVENUE RECONSTRUCTION  
IL 251 AND FAP 0525  
11TH ST TO 20TH ST**

DRAWN BY: LDI  
APPROVED BY: R.A.L.  
DATE: 08/12/15  
SCALE: TRUE 1/2

| REVISIONS |             |      |
|-----------|-------------|------|
| REV. NO.  | DESCRIPTION | DATE |
|           |             |      |
|           |             |      |
|           |             |      |

DRAWING:  
**PROPOSED LIGHTING PLAN  
HARRISON AVENUE AND SIDE STREETS**

JOB NUMBER:  
**13-1070**  
SHEET NUMBER:  
**356 of 588**



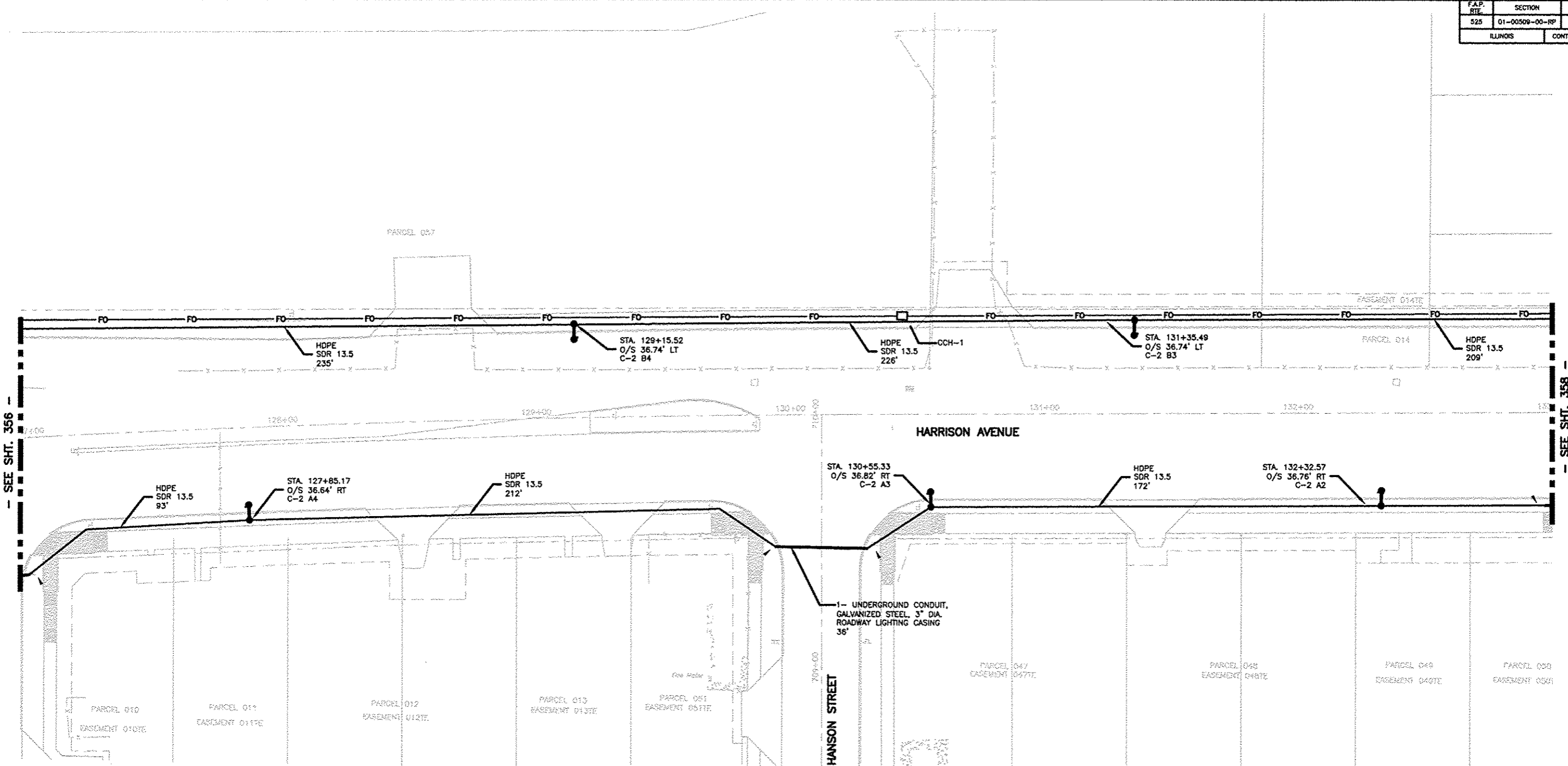

- SEE SHT. 356 -

- SEE SHT. 358 -

| LEGEND |  |
|--------|--|
|        | EXISTING ROADWAY LIGHTPOLE AND LUMINAIRE TO BE REMOVED, SALVAGE  |
|        | PROPOSED DECORATIVE LIGHT POLE AND LUMINAIRE ALUMINUM, 40 FT. MOUNTING HEIGHT PULSE START METAL HALIDE, HORIZONTAL MOUNT 400 WATT 6'-0" ARM UNLESS NOTED |
|        | HH = PROPOSED HANDHOLE PER IDOT STD 814001   |
|        | CCH = PROPOSED HANDHOLE, COMPOSITE CONCRETE TYPE AS INDICATED  |
|        | PROPOSED JUNCTION BOX  |
|        | PROPOSED UTILITY POLE (BY OTHERS)  |
|        | PROPOSED LIGHTING CONTROLLER, 100 AMP, 480V  |
|        | PROPOSED CONDUIT ATTACHED TO STRUCTURE, SIZE AND CONDUCTORS AS INDICATED   |
|        | PROPOSED UNDERGROUND CONDUIT, GALVANIZED STEEL, BORED AND PULLED SIZE AND CONDUCTORS AS INDICATED  |
|        | PROPOSED HDPE, 600V, 2-1/C NO. 6, 1/C NO. 6 GROUND, (XLP-TYPE USE), 2" DIA. POLYETHYLENE   |
|        | PROPOSED UNDERGROUND CONDUIT, GALVANIZED STEEL, SIZE AND CONDUCTORS AS INDICATED   |
|        | FO = PROPOSED UNDERGROUND CONDUIT, COILABLE NONMETALIC, 2" DIA. WITH PULL STRING AND 1-1/C NO. 12 TRACER CABLE.  |

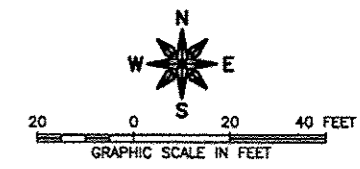

**FEHR GRAHAM**  
ENGINEERING & ENVIRONMENTAL  
ILLINOIS DESIGN FIRM NO. 184-003529  
© 2013 FEHR GRAHAM

ILLINOIS  
IOWA  
WISCONSIN

OWNER/DEVELOPER:  
**Legacy Designs, Inc.**  
6118 Mallard Village Drive  
SCOTSDALE, ILLINOIS 61357  
Professional Design Firm No. 184-003493  
815-481-6708 Phone 815-481-6710 Fax  
e-mail: legacy@legacydesigns.com  
web site: www.legacydesigns.com

PROJECT AND LOCATION:  
**HARRISON AVENUE RECONSTRUCTION  
IL 251 AND FAP 0525  
11TH ST TO 20TH ST**

DRAWN BY: LDI  
APPROVED BY: R.A.L.  
DATE: 06/12/15  
SCALE: TRUE 1/2

| REVISIONS |             |      |
|-----------|-------------|------|
| REV. NO.  | DESCRIPTION | DATE |
|           |             |      |
|           |             |      |
|           |             |      |

DRAWING:  
**PROPOSED LIGHTING PLAN  
HARRISON AVENUE AND SIDE STREETS**

JOB NUMBER:  
**13-1070**  
SHEET NUMBER:  
**357 of 588**

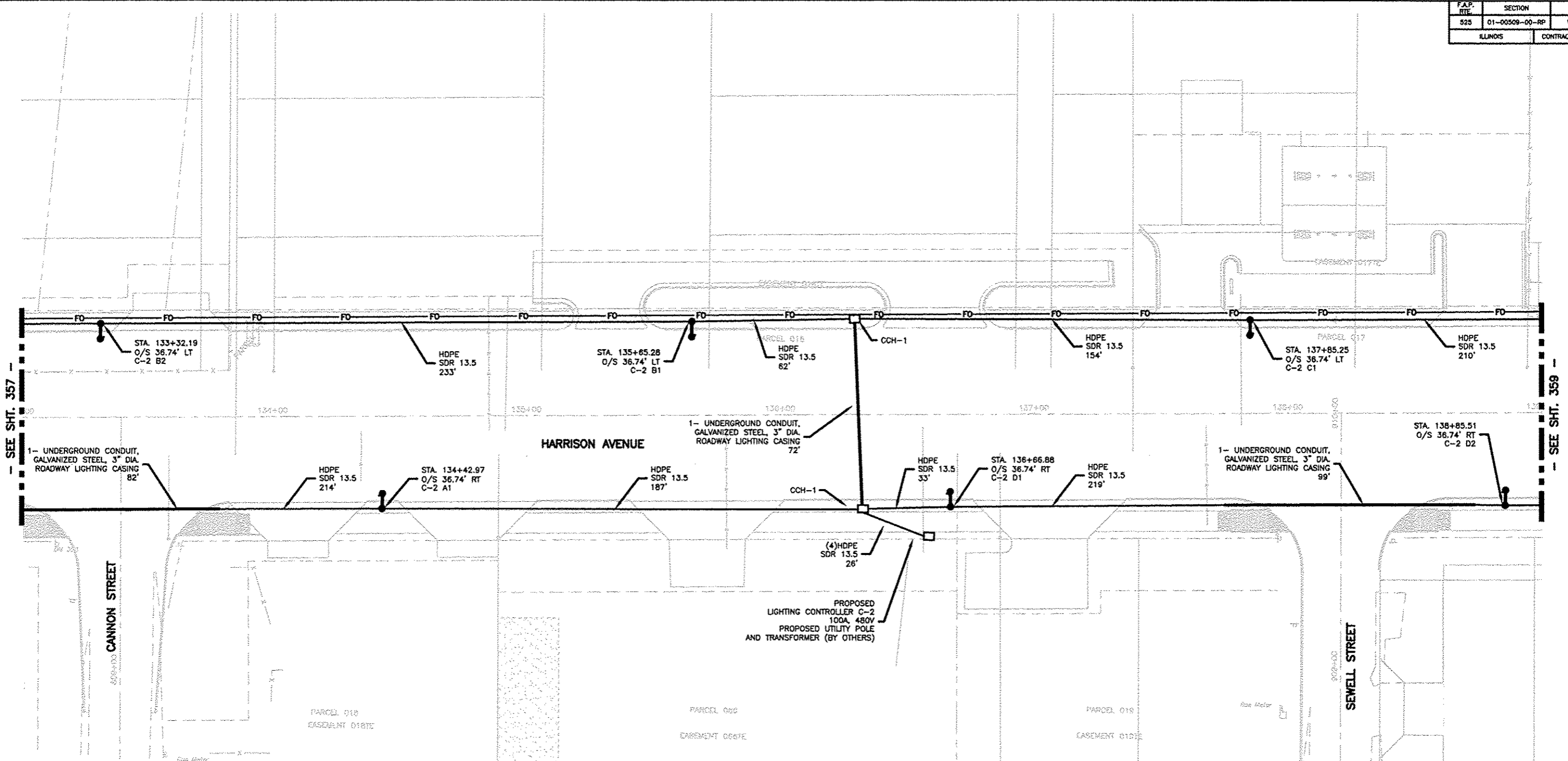

SEE SHT. 357

SEE SHT. 359

**LEGEND**

- EXISTING ROADWAY LIGHTPOLE AND LUMINAIRE TO BE REMOVED, SALVAGE
- PROPOSED DECORATIVE LIGHT POLE AND LUMINAIRE ALUMINUM, 40 FT. MOUNTING HEIGHT PULSE START METAL HALIDE, HORIZONTAL MOUNT 400 WATT 6'-0" ARM UNLESS NOTED
- HH = PROPOSED HANDHOLE PER IDOT STD 814001  
CCH = PROPOSED HANDHOLE, COMPOSITE CONCRETE TYPE AS INDICATED
- ▣ PROPOSED JUNCTION BOX
- PROPOSED UTILITY POLE (BY OTHERS)
- PROPOSED LIGHTING CONTROLLER, 100 AMP, 480V
- PROPOSED CONDUIT ATTACHED TO STRUCTURE, SIZE AND CONDUCTORS AS INDICATED
- PROPOSED UNDERGROUND CONDUIT, GALVANIZED STEEL, BORED AND PULLED SIZE AND CONDUCTORS AS INDICATED
- PROPOSED HDPE, 600V, 2-1/C NO. 6, 1/C NO. 6 GROUND, (XLP-TYPE USE), 2" DIA. POLYETHYLENE
- PROPOSED UNDERGROUND CONDUIT, GALVANIZED STEEL, SIZE AND CONDUCTORS AS INDICATED
- FO- PROPOSED UNDERGROUND CONDUIT, COILABLE NONMETALIC, 2" DIA. WITH PULL STRING AND 1-1/C NO. 12 TRACER CABLE.

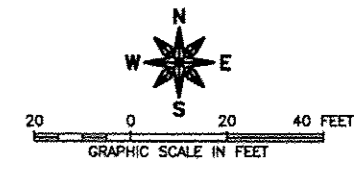

**FEHR GRAHAM**  
ENGINEERING & ENVIRONMENTAL  
ILLINOIS DESIGN FIRM NO. 104-003525  
© 2013 FEHR GRAHAM

ILLINOIS  
IOWA  
WISCONSIN

OWNER/DEVELOPER:  
**Legacy Designs, Inc.**  
6118 Mulford Village Drive  
ROCKFORD, ILLINOIS 61107  
Professional Design Firm No. 104-003483  
815-994-6708 Phone 815-994-6710 Fax  
e-mail: legacydesigns@legdesign.net  
web site: www.legacydesigns.net

PROJECT AND LOCATION:  
**HARRISON AVENUE RECONSTRUCTION  
IL 251 AND FAP 0525  
11TH ST TO 20TH ST**

DRAWN BY: LDI  
APPROVED BY: R.A.L.  
DATE: 06/12/15  
SCALE: TRUE 1/2

| REVISIONS |             |      |
|-----------|-------------|------|
| REV. NO.  | DESCRIPTION | DATE |
|           |             |      |
|           |             |      |
|           |             |      |

DRAWING:  
**PROPOSED LIGHTING PLAN  
HARRISON AVENUE AND SIDE STREETS**

JOB NUMBER:  
**13-1070**

SHEET NUMBER:  
**358 of 588**

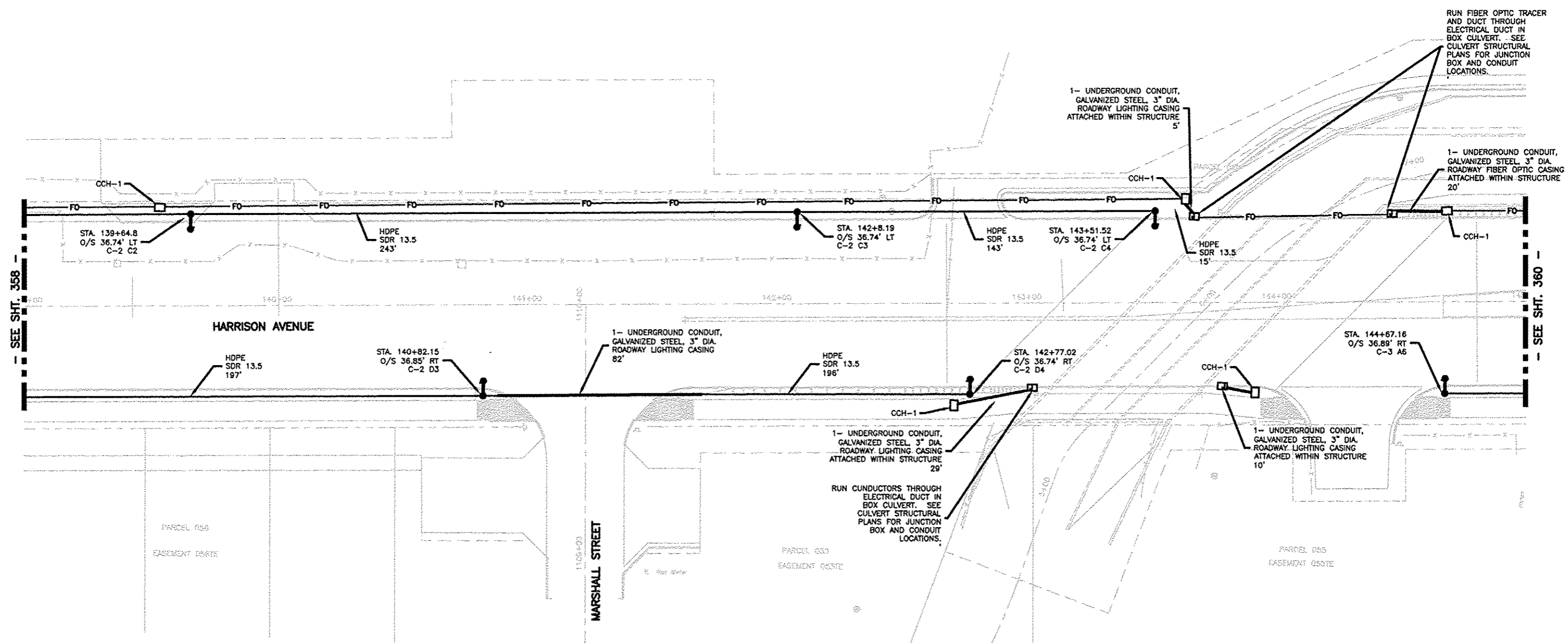

**LEGEND**

|   |  |
|---|--|
| <ul style="list-style-type: none"> <li>○ EXISTING ROADWAY LIGHTPOLE AND LUMINAIRE TO BE REMOVED, SALVAGE</li> <li>● PROPOSED DECORATIVE LIGHT POLE AND LUMINAIRE ALUMINUM, 40 FT. MOUNTING HEIGHT PULSE START METAL HALIDE, HORIZONTAL MOUNT 400 WATT 6'-0" ARM UNLESS NOTED</li> <li>□ HH = PROPOSED HANDHOLE PER IDOT STD 814001</li> <li>□ CCH = PROPOSED HANDHOLE, COMPOSITE CONCRETE TYPE AS INDICATED</li> <li>□ PROPOSED JUNCTION BOX</li> <li>□ PROPOSED UTILITY POLE (BY OTHERS)</li> <li>□ PROPOSED LIGHTING CONTROLLER, 100 AMP, 480V</li> </ul> | <ul style="list-style-type: none"> <li>— PROPOSED CONDUIT ATTACHED TO STRUCTURE, SIZE AND CONDUCTORS AS INDICATED</li> <li>— PROPOSED UNDERGROUND CONDUIT, GALVANIZED STEEL, BORED AND PULLED SIZE AND CONDUCTORS AS INDICATED</li> <li>— PROPOSED HDPE, 600V, 2-1/C NO. 6, 1/C NO. 6 GROUND, (XLP-TYPE USE), 2" DIA. POLYETHYLENE</li> <li>— PROPOSED UNDERGROUND CONDUIT, GALVANIZED STEEL, SIZE AND CONDUCTORS AS INDICATED</li> <li>— FO — PROPOSED UNDERGROUND CONDUIT, COILABLE NONMETALIC, 2" DIA. WITH PULL STRING AND 1-1/C NO. 12 TRACER CABLE.</li> </ul> |
|---|--|

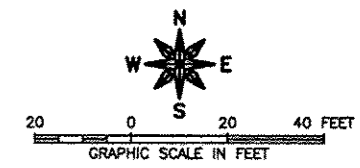

| REVISIONS |             |      |
|-----------|-------------|------|
| REV. NO.  | DESCRIPTION | DATE |
|           |             |      |
|           |             |      |
|           |             |      |

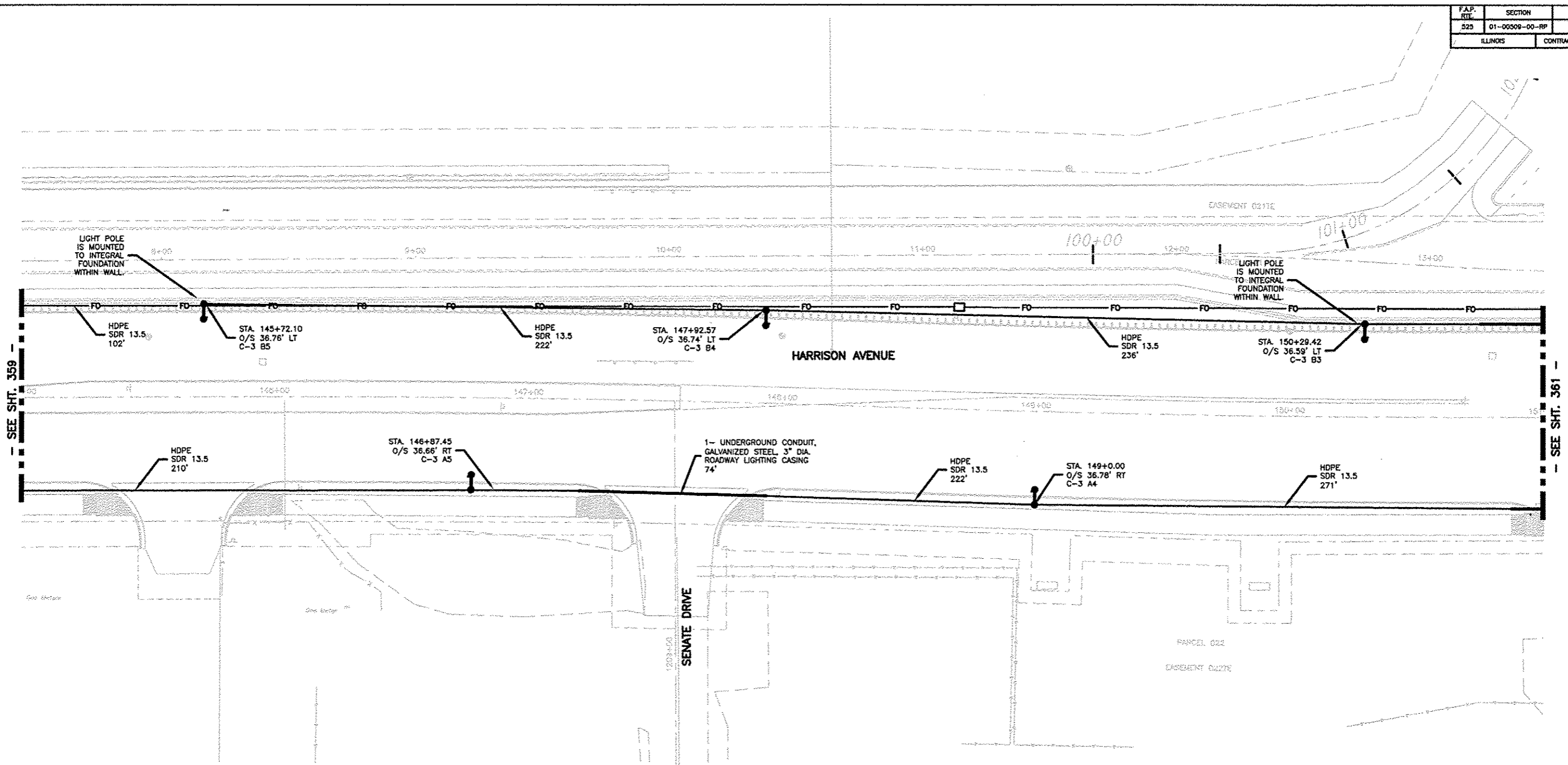

**LEGEND**

- EXISTING ROADWAY LIGHTPOLE AND LUMINAIRE TO BE REMOVED, SALVAGE
- PROPOSED DECORATIVE LIGHT POLE AND LUMINAIRE ALUMINUM, 40 FT. MOUNTING HEIGHT PULSE START METAL HALIDE, HORIZONTAL MOUNT 400 WATT 6'-0" ARM UNLESS NOTED
- HH = PROPOSED HANDHOLE PER IDOT STD B14001  
CCH = PROPOSED HANDHOLE, COMPOSITE CONCRETE TYPE AS INDICATED
- ▣ PROPOSED JUNCTION BOX
- PROPOSED UTILITY POLE (BY OTHERS)
- PROPOSED LIGHTING CONTROLLER, 100 AMP, 480V
- PROPOSED CONDUIT ATTACHED TO STRUCTURE, SIZE AND CONDUCTORS AS INDICATED
- PROPOSED UNDERGROUND CONDUIT, GALVANIZED STEEL, BORED AND PULLED SIZE AND CONDUCTORS AS INDICATED
- PROPOSED HDPE, 600V, 2-1/C NO. 6, 1/C NO. 6 GROUND, (XLP-TYPE USE), 2" DIA. POLYETHYLENE
- PROPOSED UNDERGROUND CONDUIT, GALVANIZED STEEL, SIZE AND CONDUCTORS AS INDICATED
- FO— PROPOSED UNDERGROUND CONDUIT, COILABLE NONMETALIC, 2" DIA. WITH PULL STRING AND 1-1/C NO. 12 TRACER CABLE.

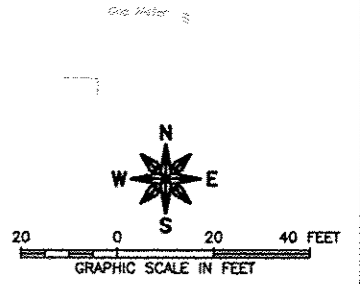

**FEHR GRAHAM**  
ENGINEERING & ENVIRONMENTAL  
ILLINOIS DESIGN FIRM NO. 104-003525  
© 2013 FEHR GRAHAM

ILLINOIS  
IOWA  
WISCONSIN

OWNER/DEVELOPER:  
**Legacy Designs, Inc.**  
6116 Mulford Village Drive  
McDonough, IL 61758 81577  
Professional Design Firm No. 104-003483  
815-684-4708 Fax 815-684-6710  
www.legacydesigns.com

PROJECT AND LOCATION:  
**HARRISON AVENUE RECONSTRUCTION  
IL 251 AND FAP 0525  
11TH ST TO 20TH ST**

DRAWN BY: LDI  
APPROVED BY: R.A.L.  
DATE: 08/12/15  
SCALE: TRUE 1/2

| REVISIONS |             |      |
|-----------|-------------|------|
| REV. NO.  | DESCRIPTION | DATE |
|           |             |      |
|           |             |      |
|           |             |      |

DRAWING:  
**PROPOSED LIGHTING PLAN  
HARRISON AVENUE AND SIDE STREETS**

JOB NUMBER:  
**13-1070**  
SHEET NUMBER:  
**360 of 588**

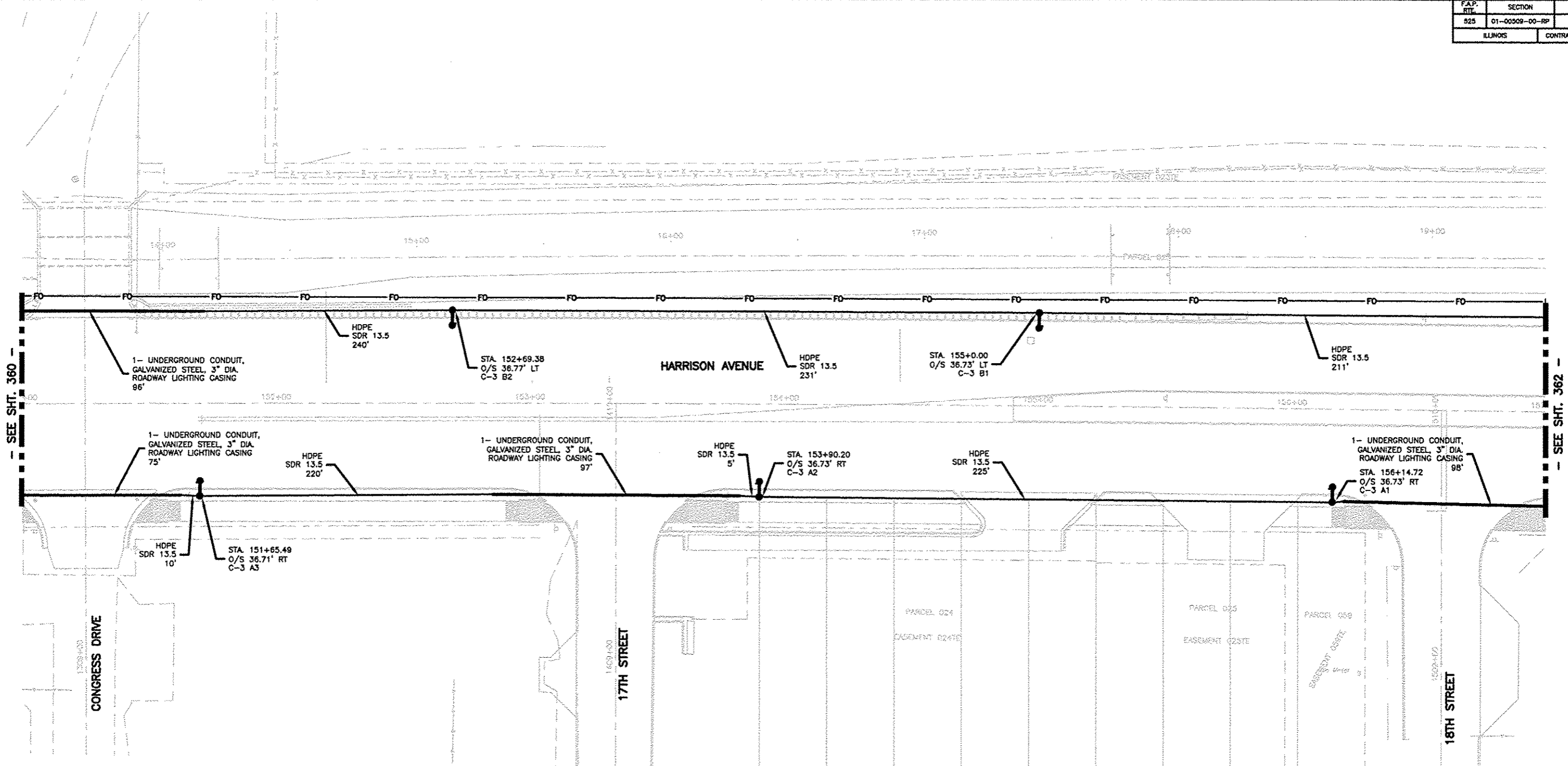

**LEGEND**

|   |  |      |  |
|---|--|------|--|
| ○ | EXISTING ROADWAY LIGHTPOLE AND LUMINAIRE TO BE REMOVED, SALVAGE  | —    | PROPOSED CONDUIT ATTACHED TO STRUCTURE, SIZE AND CONDUCTORS AS INDICATED                                   |
| ● | PROPOSED DECORATIVE LIGHT POLE AND LUMINAIRE ALUMINUM, 40 FT. MOUNTING HEIGHT PULSE START METAL HALIDE, HORIZONTAL MOUNT 400 WATT 6'-0" ARM UNLESS NOTED | —    | PROPOSED UNDERGROUND CONDUIT, GALVANIZED STEEL, BORED AND PULLED SIZE AND CONDUCTORS AS INDICATED          |
| □ | HH = PROPOSED HANDHOLE PER IDOT STD 814001<br>CCH = PROPOSED HANDHOLE, COMPOSITE CONCRETE TYPE AS INDICATED  | —    | PROPOSED HDPE, 600V, 2-1/C NO. 6, 1/C NO. 6 GROUND, (XLP-TYPE USE), 2" DIA. POLYETHYLENE                   |
| ▣ | PROPOSED JUNCTION BOX  | —    | PROPOSED UNDERGROUND CONDUIT, GALVANIZED STEEL, SIZE AND CONDUCTORS AS INDICATED                           |
| □ | PROPOSED UTILITY POLE (BY OTHERS)  | —FO— | PROPOSED UNDERGROUND CONDUIT, COILABLE NONMETALIC, 2" DIA. WITH PULL STRING AND 1-1/C NO. 12 TRACER CABLE. |
| □ | PROPOSED LIGHTING CONTROLLER, 100 AMP, 480V  |      |  |

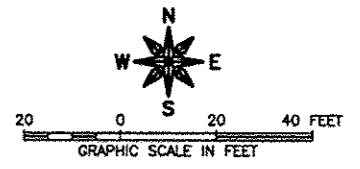

**FEHR GRAHAM**  
ENGINEERING & ENVIRONMENTAL  
ILLINOIS DESIGN FIRM NO. 184-003523  
© 2013 FEHR GRAHAM

ILLINOIS  
IOWA  
WISCONSIN

OWNER/DEVELOPER:  
**Legacy Designs, Inc.**  
6118 Midford Village Drive  
ROCKFORD, ILLINOIS 61107  
Professional Design Firm No. 184-003483  
815-994-6700 Phone 815-994-6710 Fax  
e-mail: legacydesigns@legacynet.com  
web site: www.legacydesigns.com

PROJECT AND LOCATION:  
**HARRISON AVENUE RECONSTRUCTION  
IL 251 AND FAP 0525  
11TH ST TO 20TH ST**

DRAWN BY: **LDI**  
APPROVED BY: **R.A.L.**  
DATE: **06/12/15**  
SCALE: **TRUE 1/2**

| REVISIONS |             |      |
|-----------|-------------|------|
| REV. NO.  | DESCRIPTION | DATE |
|           |             |      |
|           |             |      |
|           |             |      |

DRAWING:  
**PROPOSED LIGHTING PLAN  
HARRISON AVENUE AND SIDE STREETS**

JOB NUMBER:  
**13-1070**  
SHEET NUMBER:  
**361 of 588**

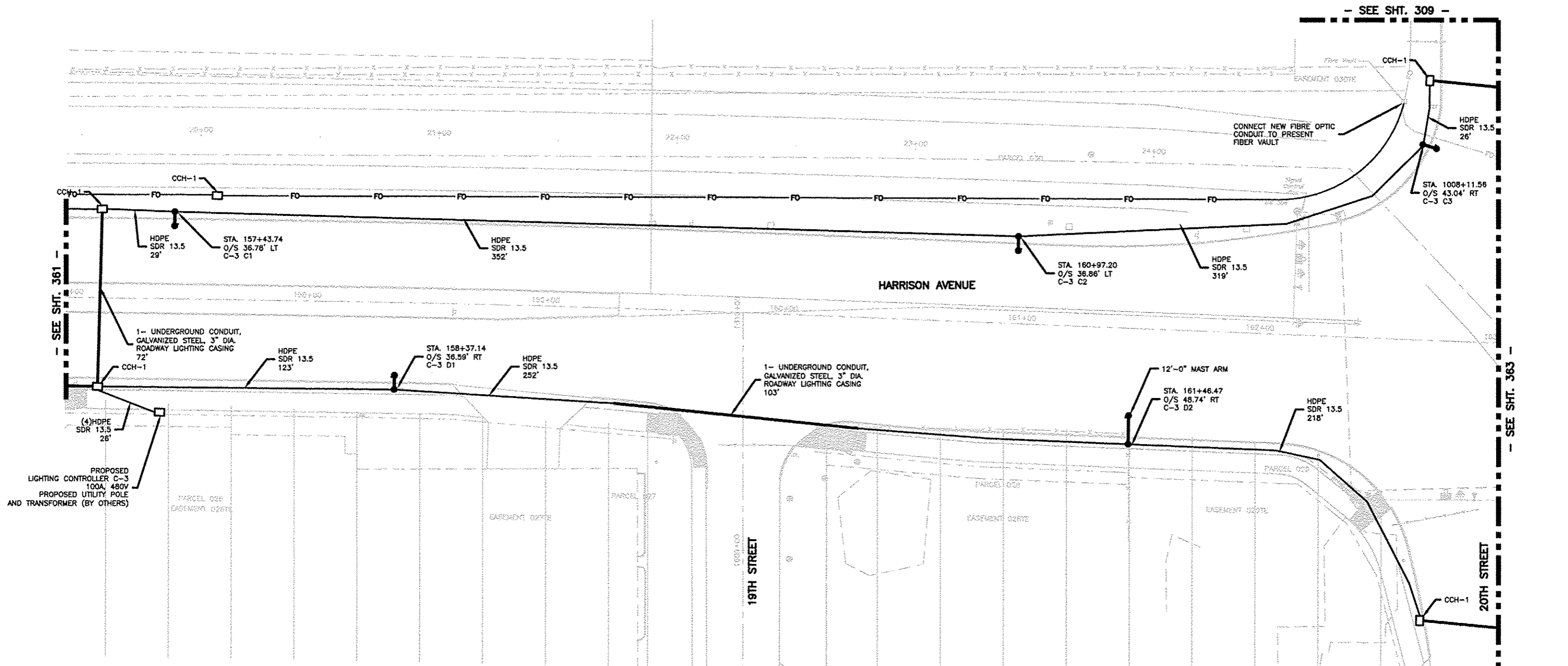

**LEGEND**

- EXISTING ROADWAY LIGHTPOLE AND LUMINAIRE TO BE REMOVED, SALVAGE
- PROPOSED DECORATIVE LIGHT POLE AND LUMINAIRE ALUMINUM, 40 FT. MOUNTING HEIGHT PULSE START METAL HALIDE, HORIZONTAL MOUNT 400 WATT 6'-0" ARM UNLESS NOTED
- HH = PROPOSED HANDHOLE PER IDOT STD 814001 CCH = PROPOSED HANDHOLE, COMPOSITE CONCRETE TYPE AS INDICATED
- ▣ PROPOSED JUNCTION BOX
- PROPOSED UTILITY POLE (BY OTHERS)
- PROPOSED LIGHTING CONTROLLER, 100 AMP, 480V
- PROPOSED CONDUIT ATTACHED TO STRUCTURE, SIZE AND CONDUCTORS AS INDICATED
- PROPOSED UNDERGROUND CONDUIT, GALVANIZED STEEL, BORED AND PULLED SIZE AND CONDUCTORS AS INDICATED
- PROPOSED HDPE, 600V, 2-1/C NO. 6, 1/C NO. 6 GROUND, (XLP-TYPE USE), 2" DIA. POLYETHYLENE
- PROPOSED UNDERGROUND CONDUIT, GALVANIZED STEEL, SIZE AND CONDUCTORS AS INDICATED
- FO — PROPOSED UNDERGROUND CONDUIT, COILABLE NONMETALIC, 2" DIA. WITH PULL STRING AND 1-1/C NO. 12 TRACER CABLE.

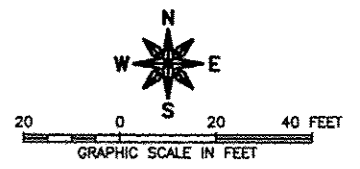

**FEHR GRAHAM**  
ENGINEERING & ENVIRONMENTAL  
ILLINOIS DESIGN FIRM NO. 184-003525  
© 2013 FEHR GRAHAM

ILLINOIS  
IOWA  
WISCONSIN

OWNER/DEVELOPER:  
**Legacy Designs, Inc.**  
6110 Mulford Village Drive  
ROCKFORD, ILLINOIS 61109  
Professional Design Firm No. 184-003463  
815-994-0700 Phone 815-994-0710 Fax  
www.legacydesigns.com  
web site www.legacydesigns.com

PROJECT AND LOCATION:  
**HARRISON AVENUE RECONSTRUCTION  
IL 251 AND FAP 0525  
11TH ST TO 20TH ST**

DRAWN BY: LDI  
APPROVED BY: R.A.L.  
DATE: 06/12/15  
SCALE: TRUE 1/2

| REVISIONS |             |      |
|-----------|-------------|------|
| REV. NO.  | DESCRIPTION | DATE |
|           |             |      |
|           |             |      |
|           |             |      |

DRAWING:  
**PROPOSED LIGHTING PLAN  
HARRISON AVENUE AND SIDE STREETS**

JOB NUMBER:  
**13-1070**

SHEET NUMBER:  
**362 of 588**

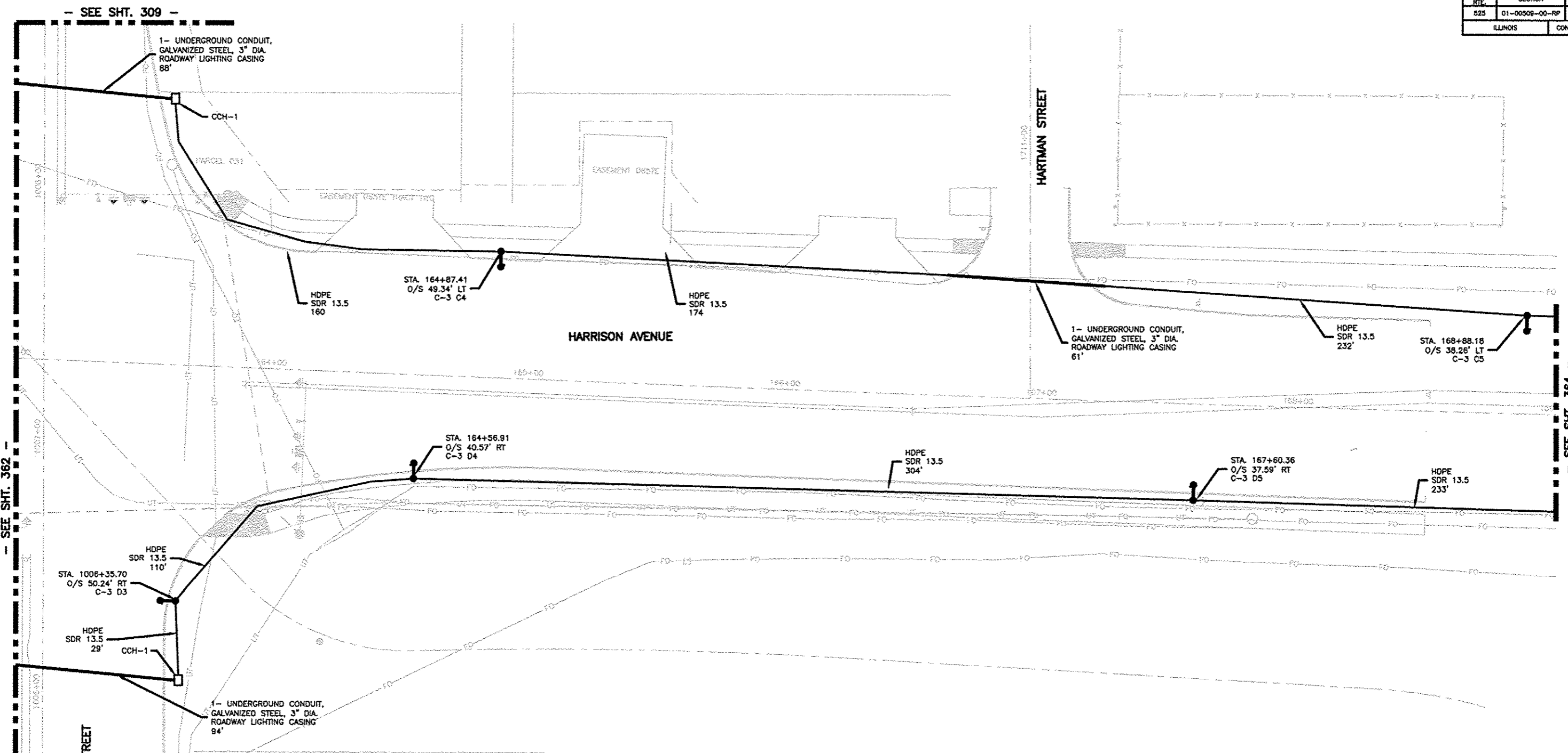

SEE SHT. 362

SEE SHT. 364

**LEGEND**

- EXISTING ROADWAY LIGHTPOLE AND LUMINAIRE TO BE REMOVED, SALVAGE
- PROPOSED DECORATIVE LIGHT POLE AND LUMINAIRE ALUMINUM, 40 FT. MOUNTING HEIGHT PULSE START METAL HALIDE, HORIZONTAL MOUNT 400 WATT 6'-0" ARM UNLESS NOTED
- HH = PROPOSED HANDHOLE PER IDOT STD 814001
- CCH = PROPOSED HANDHOLE, COMPOSITE CONCRETE TYPE AS INDICATED
- PROPOSED JUNCTION BOX
- PROPOSED UTILITY POLE (BY OTHERS)
- PROPOSED LIGHTING CONTROLLER, 100 AMP, 480V
- PROPOSED CONDUIT ATTACHED TO STRUCTURE, SIZE AND CONDUCTORS AS INDICATED
- PROPOSED UNDERGROUND CONDUIT, GALVANIZED STEEL, BORED AND PULLED SIZE AND CONDUCTORS AS INDICATED
- PROPOSED HDPE, 600V, 2-1/C NO. 6, 1/C NO. 6 GROUND, (XLP-TYPE USE), 2" DIA. POLYETHYLENE
- PROPOSED UNDERGROUND CONDUIT, GALVANIZED STEEL, SIZE AND CONDUCTORS AS INDICATED
- FO— PROPOSED UNDERGROUND CONDUIT, COILABLE NONMETALIC, 2" DIA. WITH PULL STRING AND 1-1/C NO. 12 TRACER CABLE.

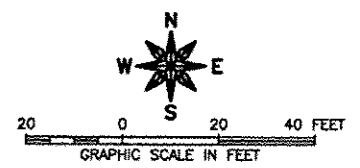

**FEHR GRAHAM**  
ENGINEERING & ENVIRONMENTAL  
ILLINOIS DESIGN FIRM NO. 184-003523  
© 2013 FEHR GRAHAM

ILLINOIS  
IOWA  
WISCONSIN

OWNER/DEVELOPER:  
**Legacy Designs, Inc.**  
8116 Stafford Village Drive  
ROCKFORD, ILLINOIS 61109  
Professional Design Firm No. 184-003483  
815-964-0708 Fax: 815-964-0710  
e-mail: legdesign@legdesign.com  
web site: www.legdesign.com

PROJECT AND LOCATION:  
**HARRISON AVENUE RECONSTRUCTION  
IL 251 AND FAP 0525  
11TH ST TO 20TH ST**

DRAWN BY: LDI  
APPROVED BY: RAL  
DATE: 08/12/15  
SCALE: TRUE 1/2

| REVISIONS |             |      |
|-----------|-------------|------|
| REV. NO.  | DESCRIPTION | DATE |
|           |             |      |
|           |             |      |
|           |             |      |

DRAWING:  
**PROPOSED LIGHTING PLAN  
HARRISON AVENUE AND SIDE STREETS**

JOB NUMBER:  
**13-1070**

SHEET NUMBER:  
**363 of 588**

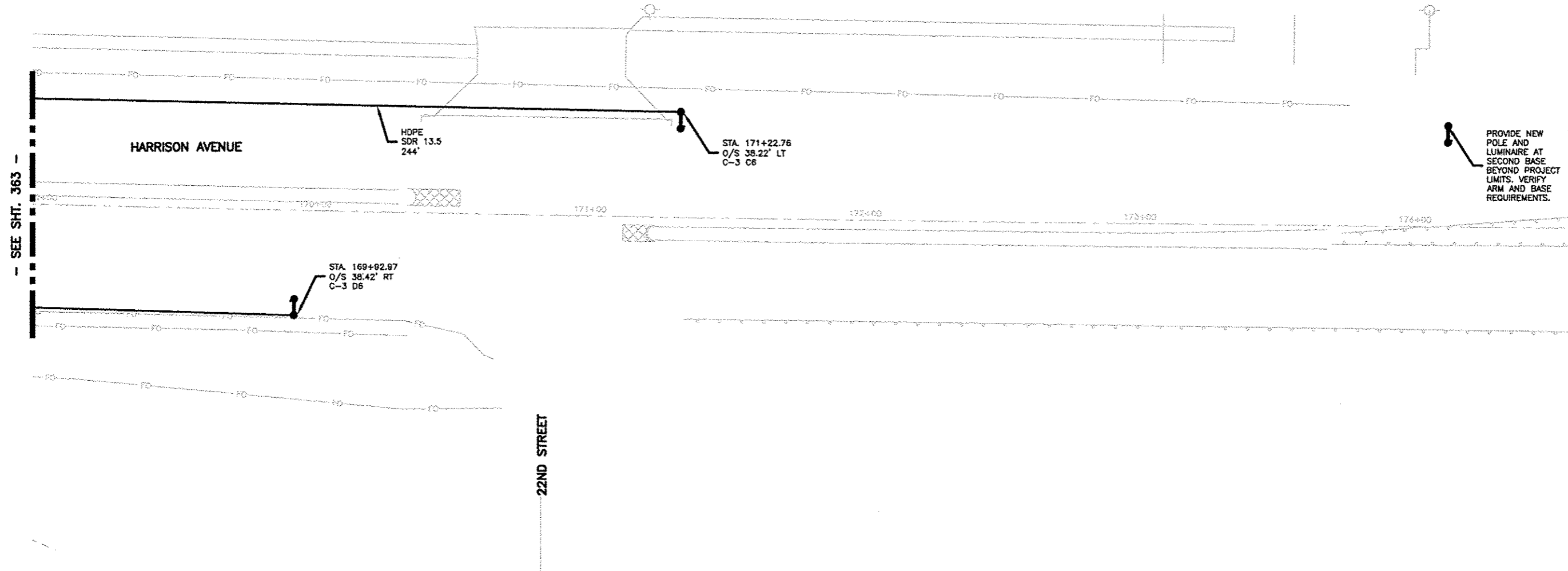

**LEGEND**

- EXISTING ROADWAY LIGHTPOLE AND LUMINAIRE TO BE REMOVED, SALVAGE
- PROPOSED DECORATIVE LIGHT POLE AND LUMINAIRE ALUMINUM, 40 FT. MOUNTING HEIGHT PULSE START METAL HALIDE, HORIZONTAL MOUNT 400 WATT 6'-0" ARM UNLESS NOTED
- HH = PROPOSED HANDHOLE PER IDOT STD 814001  
CCH = PROPOSED HANDHOLE, COMPOSITE CONCRETE TYPE AS INDICATED
- ▣ PROPOSED JUNCTION BOX
- PROPOSED UTILITY POLE (BY OTHERS)
- PROPOSED LIGHTING CONTROLLER, 100 AMP, 480V
- PROPOSED CONDUIT ATTACHED TO STRUCTURE, SIZE AND CONDUCTORS AS INDICATED
- PROPOSED UNDERGROUND CONDUIT, GALVANIZED STEEL, BORED AND PULLED SIZE AND CONDUCTORS AS INDICATED
- PROPOSED HDPE, 600V, 2-1/C NO. 6, 1/C NO. 6 GROUND, (XLP-TYPE USE), 2" DIA. POLYETHYLENE
- PROPOSED UNDERGROUND CONDUIT, GALVANIZED STEEL, SIZE AND CONDUCTORS AS INDICATED
- FO— PROPOSED UNDERGROUND CONDUIT, COILABLE NONMETALIC, 2" DIA. WITH PULL STRING AND 1-1/C NO. 12 TRACER CABLE.

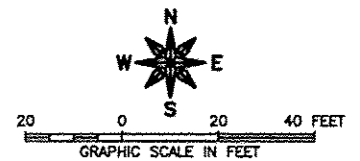

**FEHR GRAHAM**

ENGINEERING & ENVIRONMENTAL

ILLINOIS DESIGN FIRM NO. 184-003525

© 2013 FEHR GRAHAM

ILLINOIS  
IOWA  
WISCONSIN

OWNER/DEVELOPER:

**Legacy Designs, Inc.**

6110 Mulford Village Drive  
ROCKFORD, ILLINOIS 61107  
Professional Design Firm No. 184-005983  
815-994-0708 Please 815-994-0710 Fax  
e-mail: legacydesigns@comcast.net  
web site: www.legacydesigns.com

PROJECT AND LOCATION:

HARRISON AVENUE RECONSTRUCTION  
IL 251 AND FAP 0525  
11TH ST TO 20TH ST

DRAWN BY: LDI  
APPROVED BY: R.A.L.  
DATE: 06/12/15  
SCALE: TRUE 1/2

**REVISIONS**

| REV. NO. | DESCRIPTION | DATE |
|----------|-------------|------|
|          |             |      |
|          |             |      |
|          |             |      |

DRAWING:

PROPOSED LIGHTING PLAN  
HARRISON AVENUE AND SIDE STREETS

JOB NUMBER:  
13-1070

SHEET NUMBER:  
364 of 588



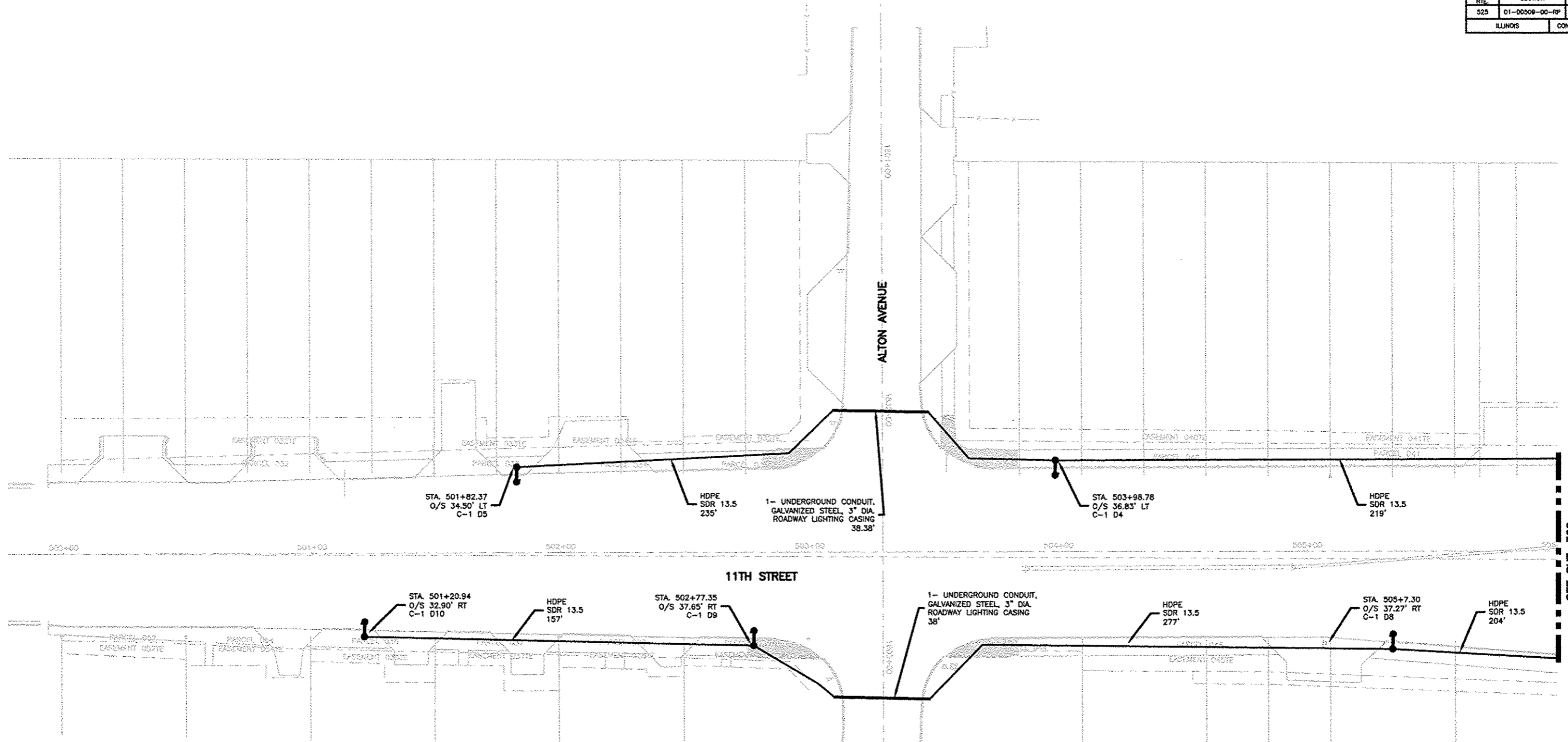

**LEGEND**

- EXISTING ROADWAY LIGHTPOLE AND LUMINAIRE TO BE REMOVED, SALVAGE
- PROPOSED DECORATIVE LIGHT POLE AND LUMINAIRE ALUMINUM, 40 FT. MOUNTING HEIGHT PULSE START METAL HALIDE, HORIZONTAL MOUNT 400 WATT 6'-0" ARM UNLESS NOTED
- HH = PROPOSED HANDHOLE PER IDOT STD 814001  
CCH = PROPOSED HANDHOLE, COMPOSITE CONCRETE TYPE AS INDICATED
- ▣ PROPOSED JUNCTION BOX
- PROPOSED UTILITY POLE (BY OTHERS)
- PROPOSED LIGHTING CONTROLLER, 100 AMP, 480V
- PROPOSED CONDUIT ATTACHED TO STRUCTURE, SIZE AND CONDUCTORS AS INDICATED
- PROPOSED UNDERGROUND CONDUIT, GALVANIZED STEEL, BORED AND PULLED SIZE AND CONDUCTORS AS INDICATED
- PROPOSED HDPE, 600V, 2-1/C NO. 6, 1/C NO. 6 GROUND, (XLP-TYPE USE), 2" DIA. POLYETHYLENE
- PROPOSED UNDERGROUND CONDUIT, GALVANIZED STEEL, SIZE AND CONDUCTORS AS INDICATED
- FO— PROPOSED UNDERGROUND CONDUIT, COILABLE NONMETALIC, 2" DIA. WITH PULL STRING AND 1-1/C NO. 12 TRACER CABLE.

SEE SHT. 366

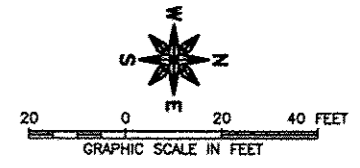

**FEHR GRAHAM**  
ENGINEERING & ENVIRONMENTAL  
ILLINOIS DESIGN FIRM NO. 184-003525  
© 2013 FEHR GRAHAM

ILLINOIS  
IOWA  
WISCONSIN

OWNER/DEVELOPER:  
**Legacy Designs, Inc.**  
8118 Mulford Village Drive  
ROCKFORD, ILLINOIS 61107  
Professional Design Firm No. 184-005483  
815-954-0028 Phone 815-954-2710 Fax  
e-mail legacydesigns@legacymd.com  
web site www.legacydesigns.com

PROJECT AND LOCATION:  
**HARRISON AVENUE RECONSTRUCTION  
IL 251 AND FAP 0525  
11TH ST TO 20TH ST**

DRAWN BY: LDI  
APPROVED BY: R.A.L.  
DATE: 08/12/15  
SCALE: TRUE 1/2

| REVISIONS |             |      |
|-----------|-------------|------|
| REV. NO.  | DESCRIPTION | DATE |
|           |             |      |
|           |             |      |
|           |             |      |

DRAWING:  
**PROPOSED LIGHTING PLAN  
11TH STREET AND SIDE STREET**

JOB NUMBER:  
**13-1070**  
SHEET NUMBER:  
**385 of 588**

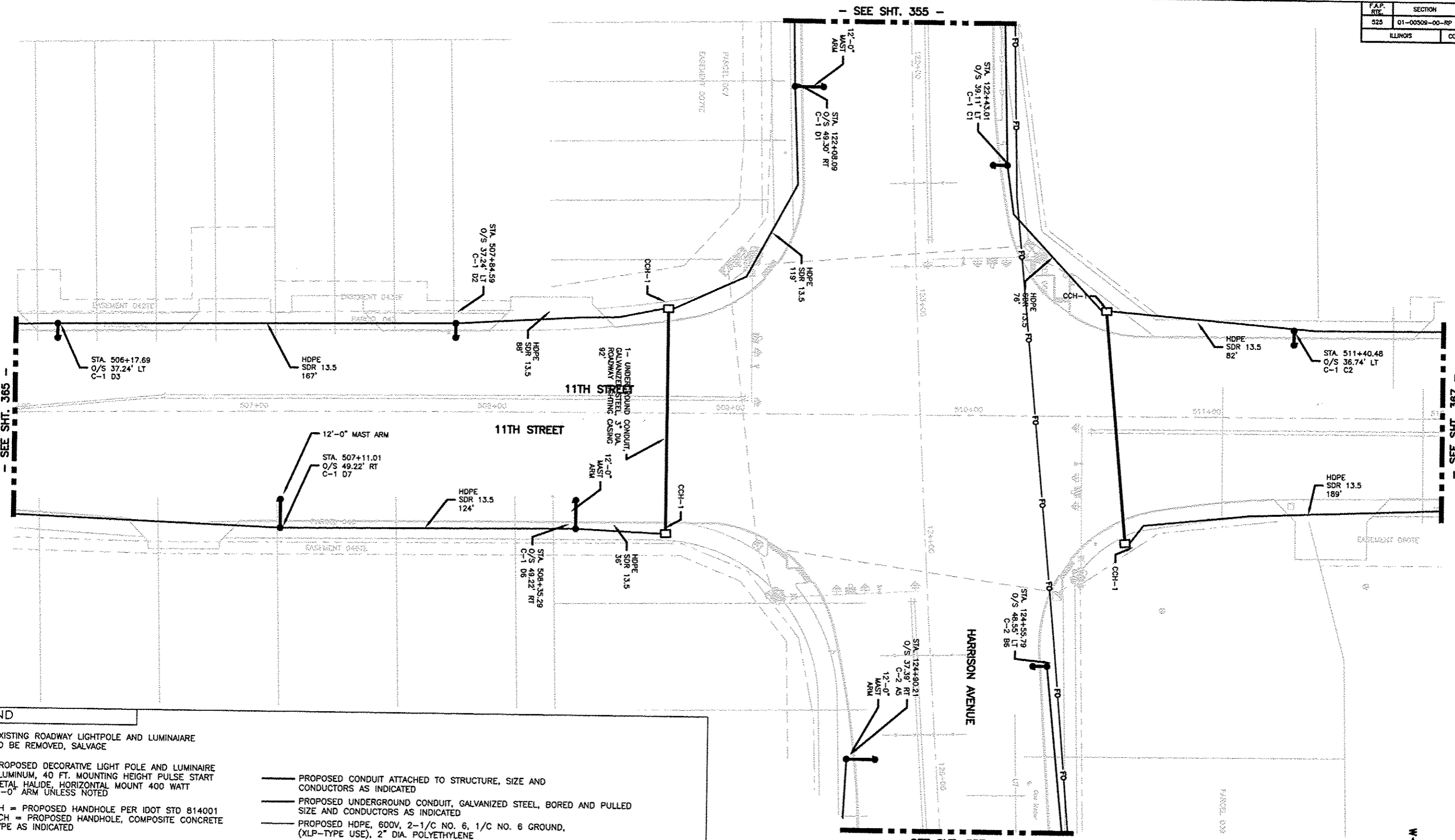

SEE SHT. 365

SEE SHT. 367

SEE SHT. 355

SEE SHT. 357

- LEGEND**
- EXISTING ROADWAY LIGHTPOLE AND LUMINAIRE TO BE REMOVED, SALVAGE
  - PROPOSED DECORATIVE LIGHT POLE AND LUMINAIRE ALUMINUM, 40 FT. MOUNTING HEIGHT PULSE START METAL HALIDE, HORIZONTAL MOUNT 400 WATT 6'-0" ARM UNLESS NOTED
  - HH = PROPOSED HANDHOLE PER IDOT STD 814001  
CCH = PROPOSED HANDHOLE, COMPOSITE CONCRETE TYPE AS INDICATED
  - PROPOSED JUNCTION BOX
  - PROPOSED UTILITY POLE (BY OTHERS)
  - PROPOSED LIGHTING CONTROLLER, 100 AMP, 480V
  - PROPOSED CONDUIT ATTACHED TO STRUCTURE, SIZE AND CONDUCTORS AS INDICATED
  - PROPOSED UNDERGROUND CONDUIT, GALVANIZED STEEL, BORED AND PULLED SIZE AND CONDUCTORS AS INDICATED
  - PROPOSED HDPE, 600V, 2-1/C NO. 6, 1/C NO. 6 GROUND, (XLP-TYPE USE), 2" DIA. POLYETHYLENE
  - PROPOSED UNDERGROUND CONDUIT, GALVANIZED STEEL, SIZE AND CONDUCTORS AS INDICATED
  - FO- PROPOSED UNDERGROUND CONDUIT, COILABLE NONMETALIC, 2" DIA. WITH PULL STRING AND 1-1/C NO. 12 TRACER CABLE.

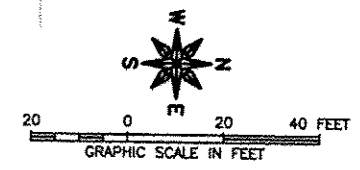

**FEHR GRAHAM**  
ENGINEERING & ENVIRONMENTAL  
ILLINOIS DESIGN FIRM NO. 184-003525  
© 2013 FEHR GRAHAM

ILLINOIS  
IOWA  
WISCONSIN

OWNER/DEVELOPER:  
**Legacy Designs, Inc.**  
8118 Mulford Village Drive  
ROCKFORD, ILLINOIS 61107  
Professional Design Firm No. 184-003483  
815-899-4708 Phone 815-899-2710 Fax  
e-mail legacy@legacydesigns.com  
web site www.legacydesigns.com

PROJECT AND LOCATION:  
**HARRISON AVENUE RECONSTRUCTION  
IL 251 AND FAP 0525  
11TH ST TO 20TH ST**

DRAWN BY: LDI  
APPROVED BY: R.A.L.  
DATE: 06/12/15  
SCALE: TRUE 1/2

| REV. NO. | DESCRIPTION | DATE |
|----------|-------------|------|
| 1        | HDPE        |      |
| 2        | 11/15       |      |
| 3        | 2/15        |      |

DRAWING:  
**PROPOSED LIGHTING PLAN  
11TH STREET AND SIDE STREET**

JOB NUMBER:  
**13-1070**

SHEET NUMBER:  
**366 of 588**

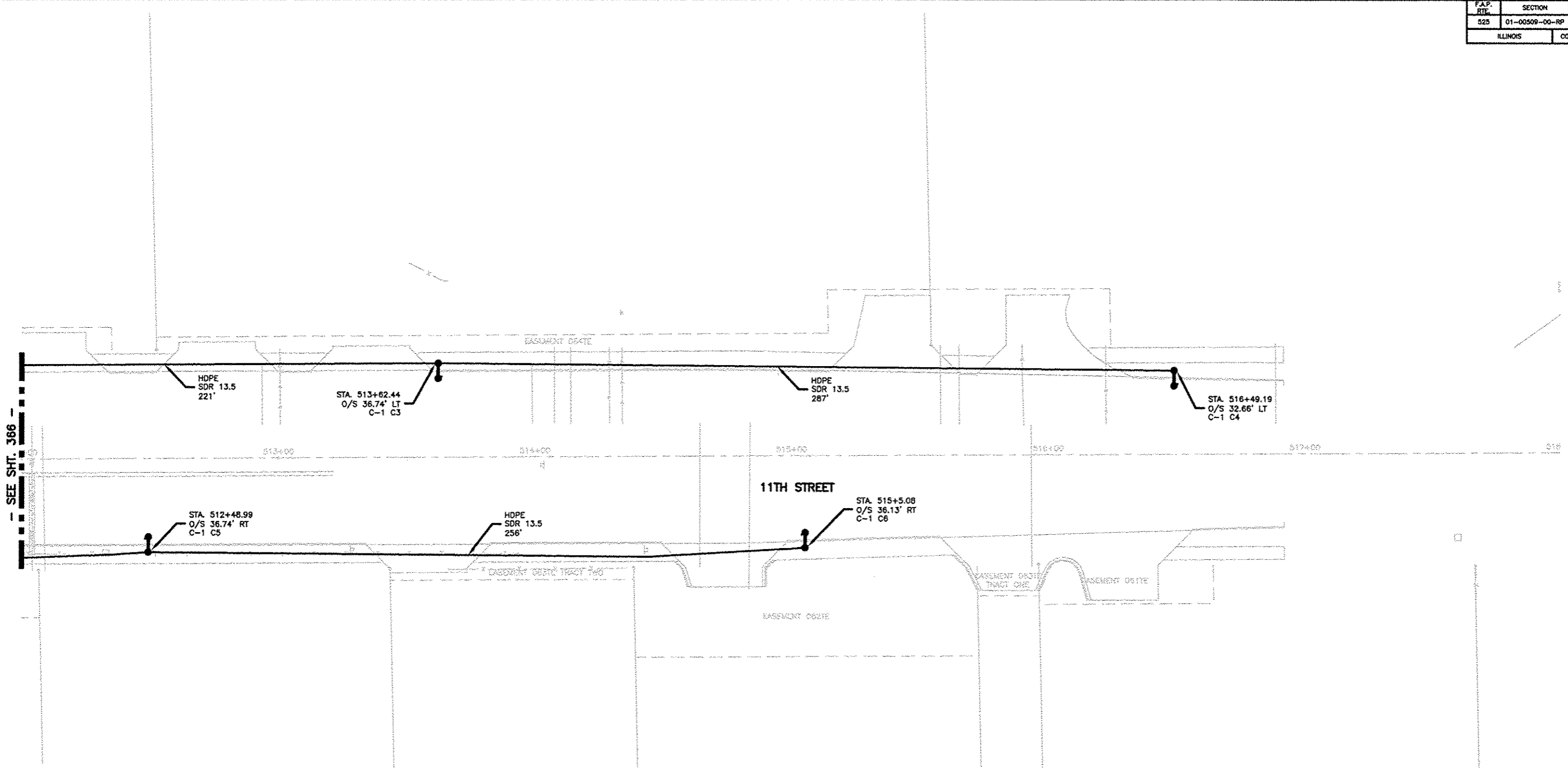

**LEGEND**

- EXISTING ROADWAY LIGHTPOLE AND LUMINAIRE TO BE REMOVED, SALVAGE
- PROPOSED DECORATIVE LIGHT POLE AND LUMINAIRE ALUMINUM, 40 FT. MOUNTING HEIGHT PULSE START METAL HALIDE, HORIZONTAL MOUNT 400 WATT 6'-0" ARM UNLESS NOTED
- HH = PROPOSED HANDHOLE PER IDOT STD 814001  
□ CCH = PROPOSED HANDHOLE, COMPOSITE CONCRETE TYPE AS INDICATED
- PROPOSED JUNCTION BOX
- PROPOSED UTILITY POLE (BY OTHERS)
- PROPOSED LIGHTING CONTROLLER, 100 AMP, 480V
- PROPOSED CONDUIT ATTACHED TO STRUCTURE, SIZE AND CONDUCTORS AS INDICATED
- PROPOSED UNDERGROUND CONDUIT, GALVANIZED STEEL, BORED AND PULLED SIZE AND CONDUCTORS AS INDICATED
- PROPOSED HDPE, 600V, 2-1/C NO. 6, 1/C NO. 6 GROUND, (XLP-TYPE USE), 2" DIA. POLYETHYLENE
- PROPOSED UNDERGROUND CONDUIT, GALVANIZED STEEL, SIZE AND CONDUCTORS AS INDICATED
- FO— PROPOSED UNDERGROUND CONDUIT, COILABLE NONMETALIC, 2" DIA. WITH PULL STRING AND 1-1/C NO. 12 TRACER CABLE.

**FEHR GRAHAM**  
ENGINEERING & ENVIRONMENTAL  
ILLINOIS DESIGN FIRM NO. 184-003325  
© 2013 FEHR GRAHAM

ILLINOIS  
IOWA  
WISCONSIN

OWNER/DEVELOPER:  
**Legacy Designs, Inc.**  
6116 Mulford Village Drive  
ROCKFORD, ILLINOIS 61107  
Professional Design Firm No. 184-003483  
815-984-4708 Fax 815-984-4710  
e-mail: legdesign@legdesign.com  
web: www.legdesign.com

PROJECT AND LOCATION:  
**HARRISON AVENUE RECONSTRUCTION  
IL 251 AND FAP 0525  
11TH ST TO 20TH ST**

DRAWN BY: LDI  
APPROVED BY: R.A.L.  
DATE: 06/12/15  
SCALE: TRUE 1/2

| REVISIONS |             |      |
|-----------|-------------|------|
| REV. NO.  | DESCRIPTION | DATE |
|           |             |      |
|           |             |      |
|           |             |      |

DRAWING:  
**PROPOSED LIGHTING PLAN  
11TH STREET**

JOB NUMBER:  
**13-1070**

SHEET NUMBER:  
**367 of 588**

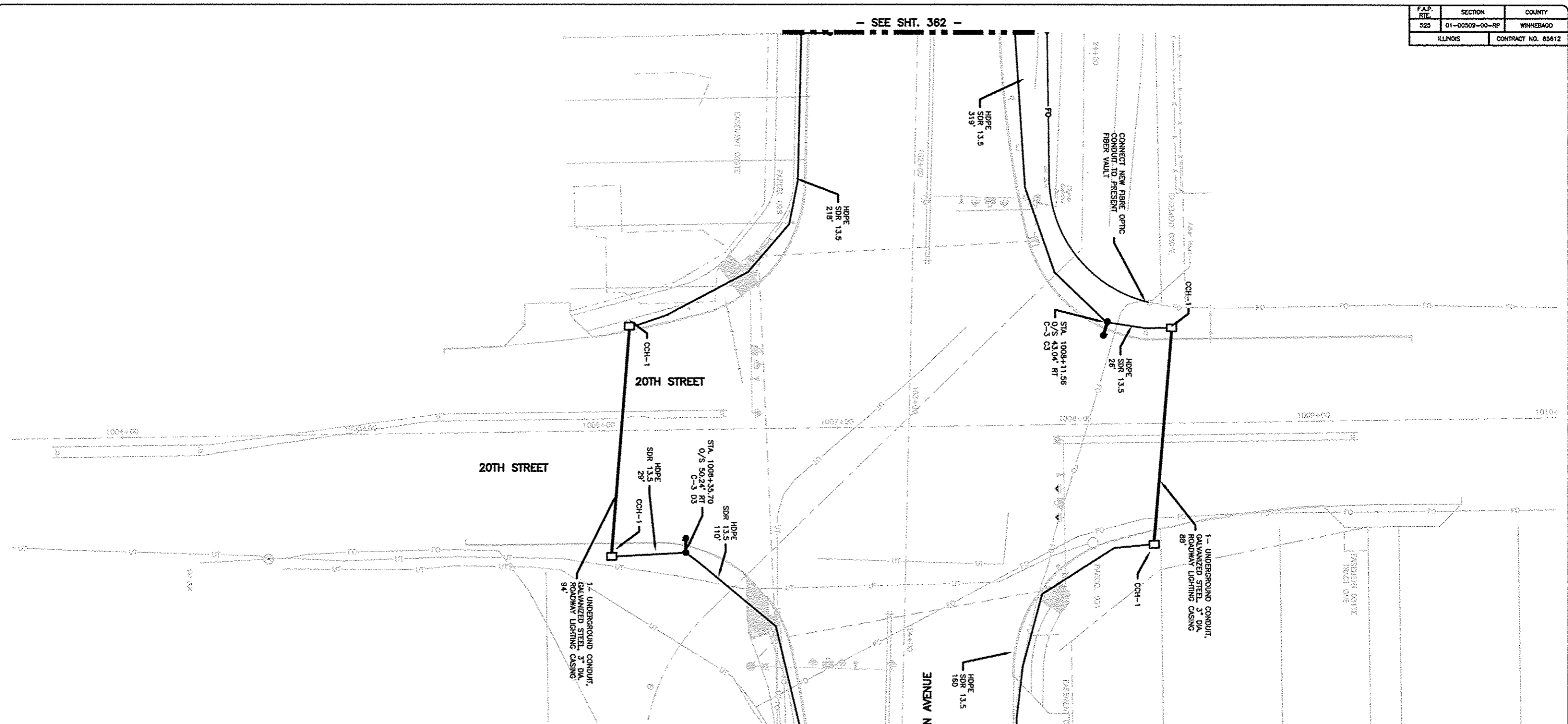

**LEGEND**

- EXISTING ROADWAY LIGHTPOLE AND LUMINAIRE TO BE REMOVED, SALVAGE
- PROPOSED DECORATIVE LIGHT POLE AND LUMINAIRE ALUMINUM, 40 FT. MOUNTING HEIGHT PULSE START METAL HALIDE, HORIZONTAL MOUNT 400 WATT 6'-0" ARM UNLESS NOTED
- HH = PROPOSED HANDHOLE PER IDOT STD 814001  
CCH = PROPOSED HANDHOLE, COMPOSITE CONCRETE TYPE AS INDICATED
- ▣ PROPOSED JUNCTION BOX
- PROPOSED UTILITY POLE (BY OTHERS)
- PROPOSED LIGHTING CONTROLLER, 100 AMP, 480V
- PROPOSED CONDUIT ATTACHED TO STRUCTURE, SIZE AND CONDUCTORS AS INDICATED
- PROPOSED UNDERGROUND CONDUIT, GALVANIZED STEEL, BORED AND PULLED SIZE AND CONDUCTORS AS INDICATED
- PROPOSED HDPE, 600V, 2-1/C NO. 6, 1/C NO. 6 GROUND, (XLP-TYPE USE), 2" DIA. POLYETHYLENE
- PROPOSED UNDERGROUND CONDUIT, GALVANIZED STEEL, SIZE AND CONDUCTORS AS INDICATED
- FO — PROPOSED UNDERGROUND CONDUIT, COILABLE NONMETALIC, 2" DIA. WITH PULL STRING AND 1-1/C NO. 12 TRACER CABLE.

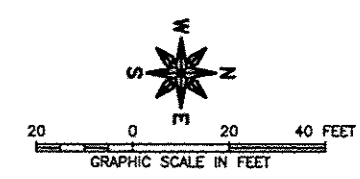

**FEHR GRAHAM**  
ENGINEERING & ENVIRONMENTAL  
ILLINOIS DESIGN FIRM NO. 184-003525  
© 2013 FEHR GRAHAM

ILLINOIS  
IOWA  
WISCONSIN

OWNER/DEVELOPER:  
**Legacy Designs, Inc.**  
6118 Mallard Village Drive  
SCOTSDALE, ILLINOIS 61107  
Professional Design Firm No. 184-003483  
616-486-6708 Phone 616-486-6710 Fax  
e-mail: info@legacydesigns.com  
web site: www.legacydesigns.com

PROJECT AND LOCATION:  
**HARRISON AVENUE RECONSTRUCTION  
IL 251 AND FAP 0525  
11TH ST TO 20TH ST**

DRAWN BY: LDI  
APPROVED BY: R.A.L.  
DATE: 06/12/15  
SCALE: TRUE 1/2

| REVISIONS |             |      |
|-----------|-------------|------|
| REV. NO.  | DESCRIPTION | DATE |
|           |             |      |
|           |             |      |
|           |             |      |

DRAWING:  
**PROPOSED LIGHTING PLAN  
20TH STREET**

JOB NUMBER:  
**13-1070**  
SHEET NUMBER:  
**368 of 588**

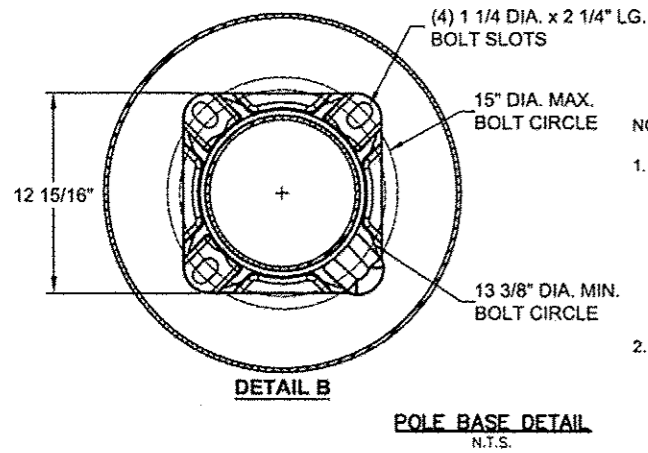

**NOTES:**

1. UNITS SHALL BE MANUFACTURED ACCORDING TO AASHTO "STANDARD SPECIFICATIONS FOR STRUCTURAL SUPPORTS FOR HIGHWAY SIGNS, LUMINAIRES AND TRAFFIC SIGNALS" CURRENT AT THE TIME THE PROJECT IS ADVERTISED. LIGHT POLES SHALL BE DESIGNED FOR 90 MPH WIND VELOCITY AND A MINIMUM DESIGN LIFE OF 50 YEARS.
2. POLES SHALL BE DESIGNED TO WITHSTAND LOADING OF 75 LB. LUMINAIRE WITH AN EPA OF 1.6 SQ. FT. INCLUDING ALL ATTACHMENTS.

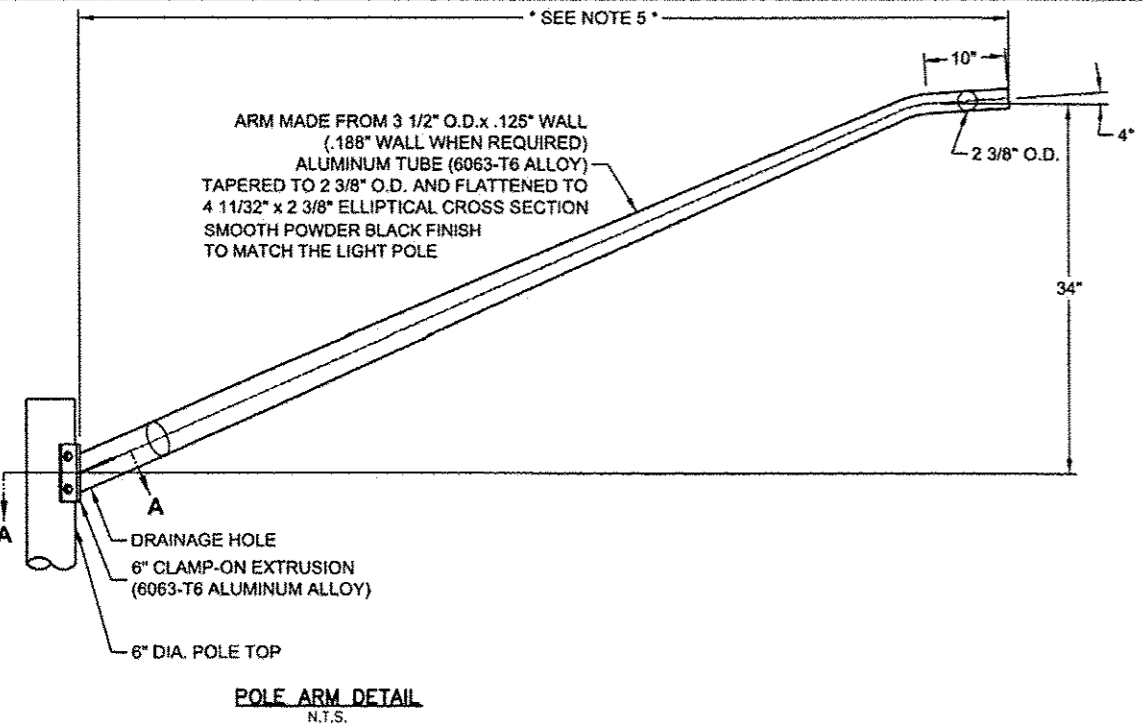
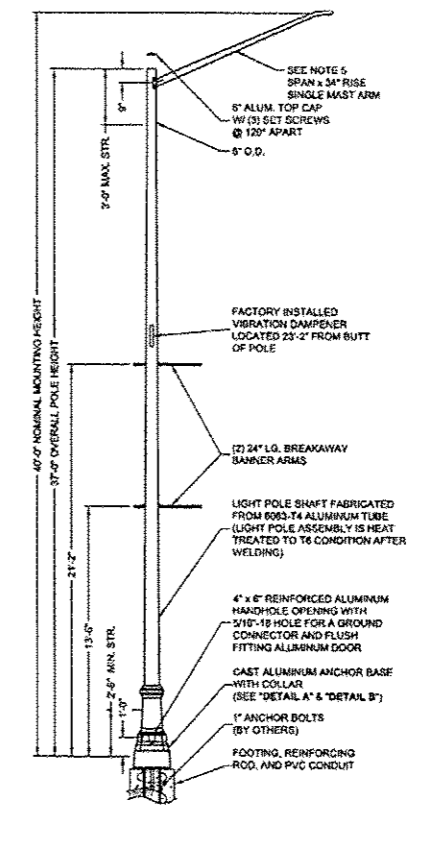
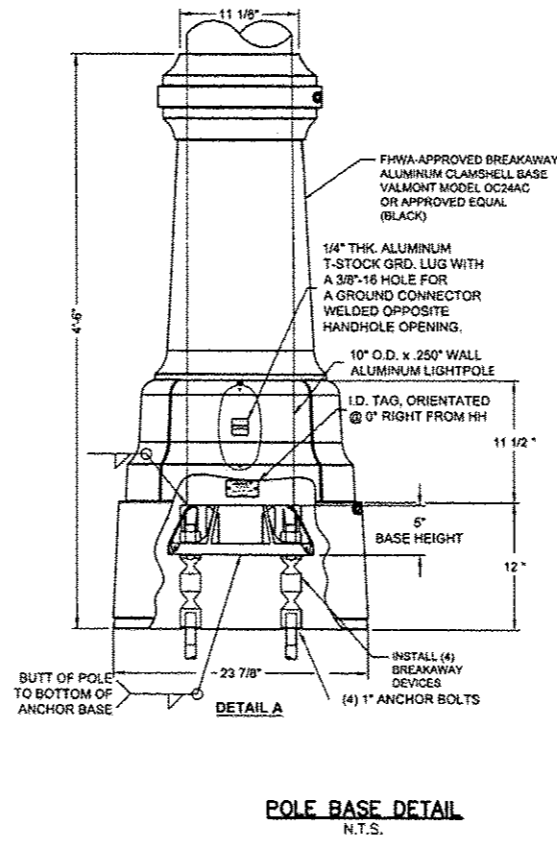

**LIGHT POLE, SPECIAL, LUMINAIRE SCHEDULE**

| TYPE                | DESCRIPTION  | MANUFACTURER | POLE   | LAMP                  | VOLTAGE |
|---------------------|--|--------------|--|-----------------------|---------|
| LIGHT POLE, SPECIAL | DOMUS 55 SERIES, TYPE III CUTOFF CATALOG DMS55-400PSMH-SG3-480V. | LUMEC        | VALMONT • 40 FT M.H., WITH CLAMSHELL BASE ON CONCRETE FOUNDATION<br>MAST ARM LENGTH AS SPECIFIED | 400W M.H. PULSE START | 480 V   |

• OR APPROVED EQUAL

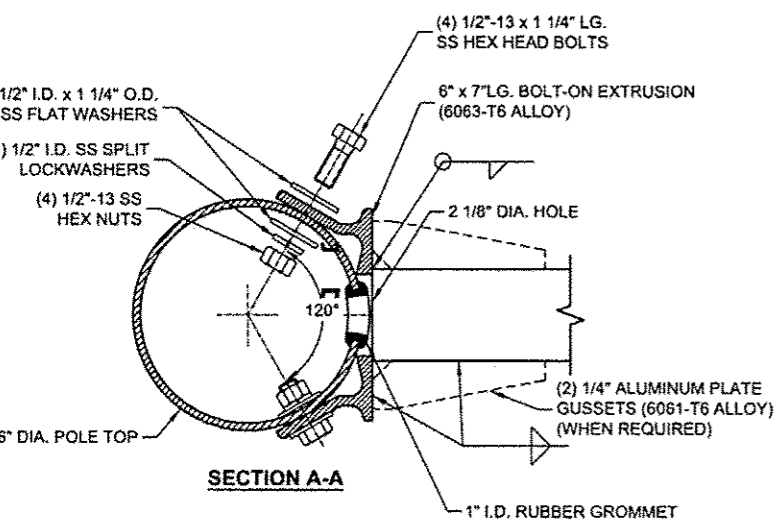

**NOTES:**

1. REFER TO ROADWAY LIGHTING DETAIL FOR LIGHT POLE FOUNDATION DETAIL PER HIGHWAY STANDARDS.
2. REFER TO ROADWAY LIGHTING DETAIL POLE WIRING DETAIL PER HIGHWAY STANDARDS.
3. REFER TO ROADWAY LIGHTING DETAIL CONDUIT TRENCH - PHOTOCELL MOUNTING
4. REFER TO DETAIL A ON THIS SHEET.
5. SPAN LENGTH SHALL BE 6', 8', 10' OR 12'. REFER TO EACH SHEET FOR WHICH LENGTH IS REQUIRED. ALL TO BE 6' UNLESS NOTED AS OTHER.

**NOTE:**

1. WELDING WIRE (ER4043).
2. MAST ARM HEAT TREATED AFTER FABRICATION TO T6 CONDITION.
3. ALL HARDWARE IS 300 SERIES STAINLESS STEEL, COATED WITH ANTI-SEIZE COMPOUND.

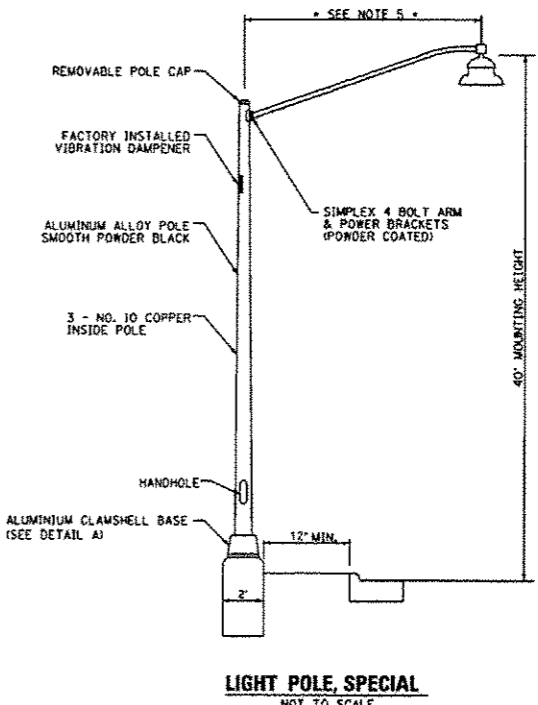
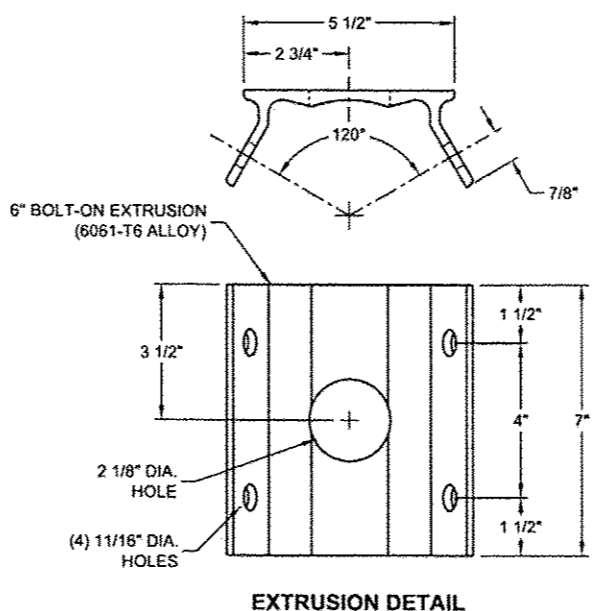

| REVISIONS |             |      |
|-----------|-------------|------|
| REV. NO.  | DESCRIPTION | DATE |
|           |             |      |
|           |             |      |
|           |             |      |

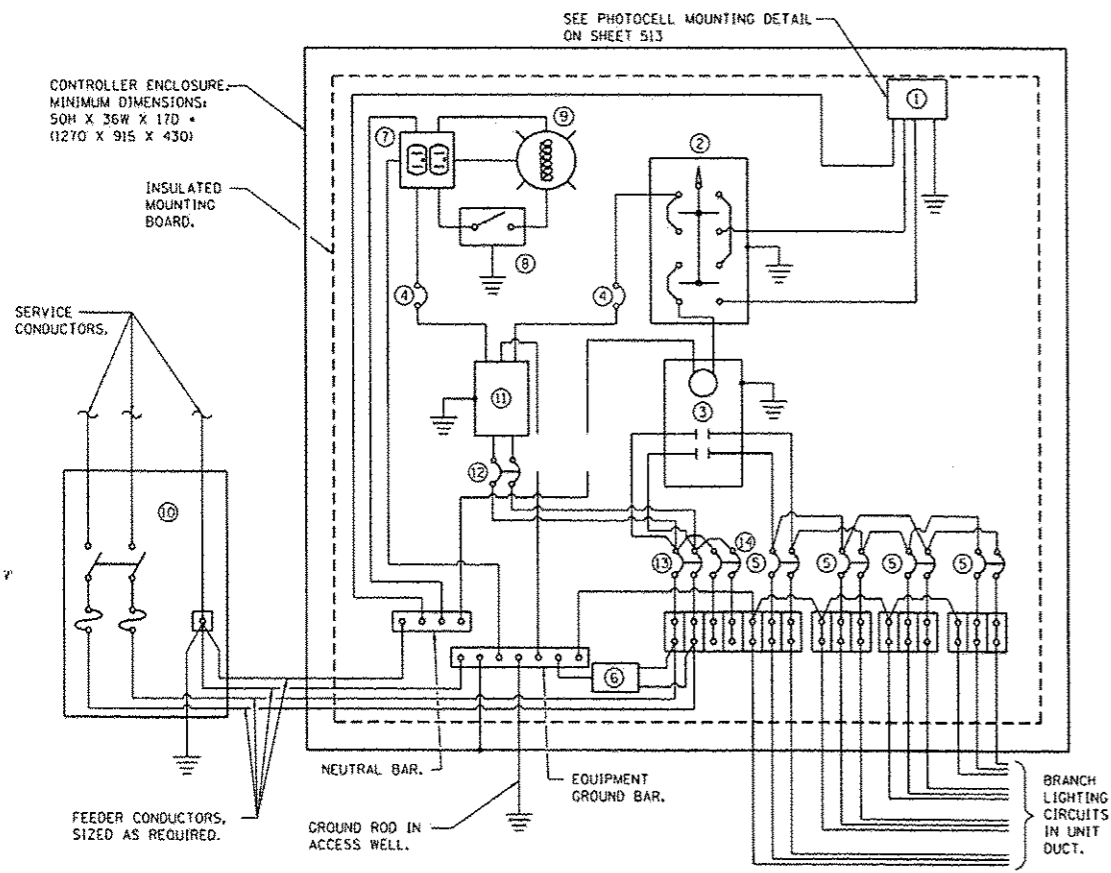

**CONTROLLER WIRING DIAGRAM**  
N.T.S.

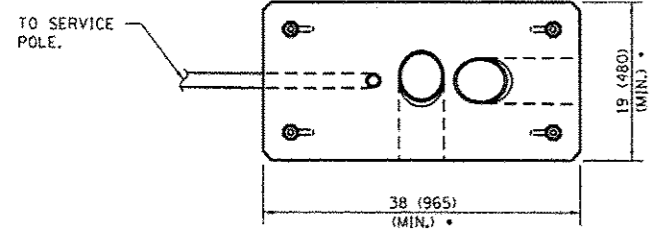

**FOUNDATION (PLAN)**  
(WORK PAD NOT SHOWN.)

- CONTROL SCHEMATIC**
- ① PHOTOCELL WITH INTEGRAL SURGE ARRESTER.
  - ② HAND-OFF-AUTO SELECTOR SWITCH.
  - ③ 100 AMP., ELECTRICALLY HELD CONTACTOR.
  - ④ 15 AMP. 1-POLE CIRCUIT BREAKER.
  - ⑤ 20 AMP., 2-POLE CIRCUIT BREAKER (TWO SPARES REQUIRED BUT NOT SHOWN).
  - ⑥ SURGE ARRESTER.
  - ⑦ GFCI DUPLEX RECEPTACLE.
  - ⑧ SINGLE-POLE, SINGLE-THROW SWITCH.
  - ⑨ INCANDESCENT LUMINAIRE, ENCLOSED AND GASKETTED WITH 100 WATT LAMP.
  - ⑩ SERVICE DISCONNECT SWITCH - 2-POLE, 3-WIRE, 100 AMP., FUSED AT 100 AMP., SOLID NEUTRAL IN NEMA 4X ENCLOSURE HAVING LOCKABLE EXTERNAL HANDLE.
  - ⑪ TRANSFORMER - 1KVA., 480V PRIMARY, 120/240V SECONDARY, SINGLE-PHASE, 60HZ.
  - ⑫ 15 AMP, 2-POLE CIRCUIT BREAKER.
  - ⑬ 100 AMP., 2-POLE CIRCUIT BREAKER.
  - ⑭ 30 AMP, 2-POLE CIRCUIT BREAKER.
- \* SIZE LARGER AS NEEDED.

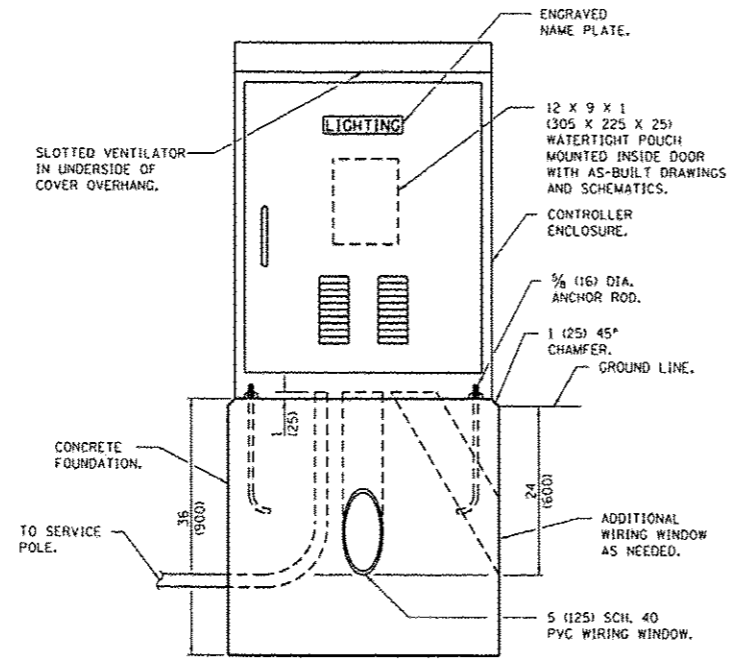

**LIGHTING CONTROLLER**

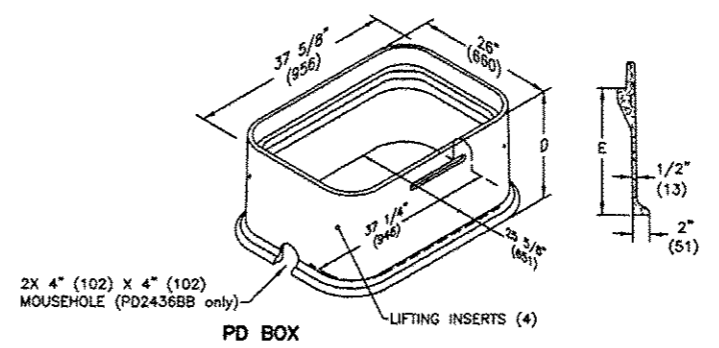
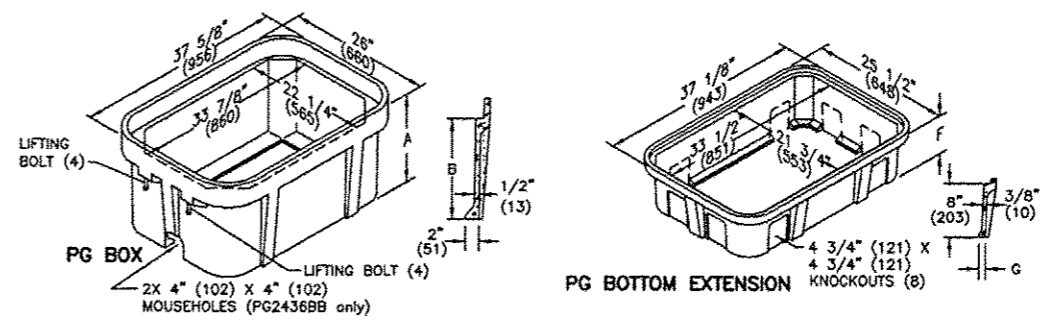
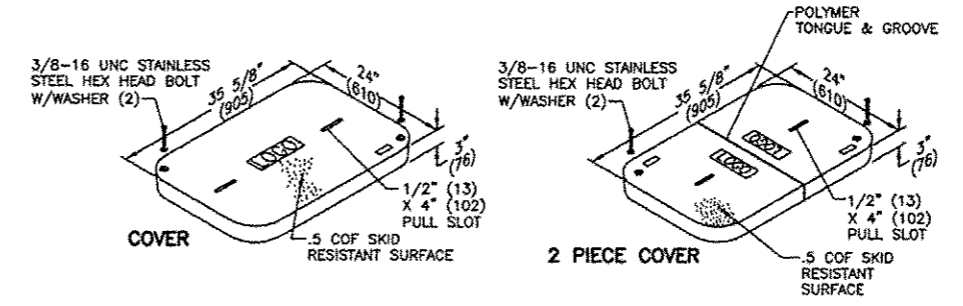

**HAND HOLE DETAIL**  
N.T.S.

NOTE: NO WIRING TO BE SPLICED BELOW GRADE.

| REVISIONS |             |      |
|-----------|-------------|------|
| REV. NO.  | DESCRIPTION | DATE |
|           |             |      |
|           |             |      |
|           |             |      |

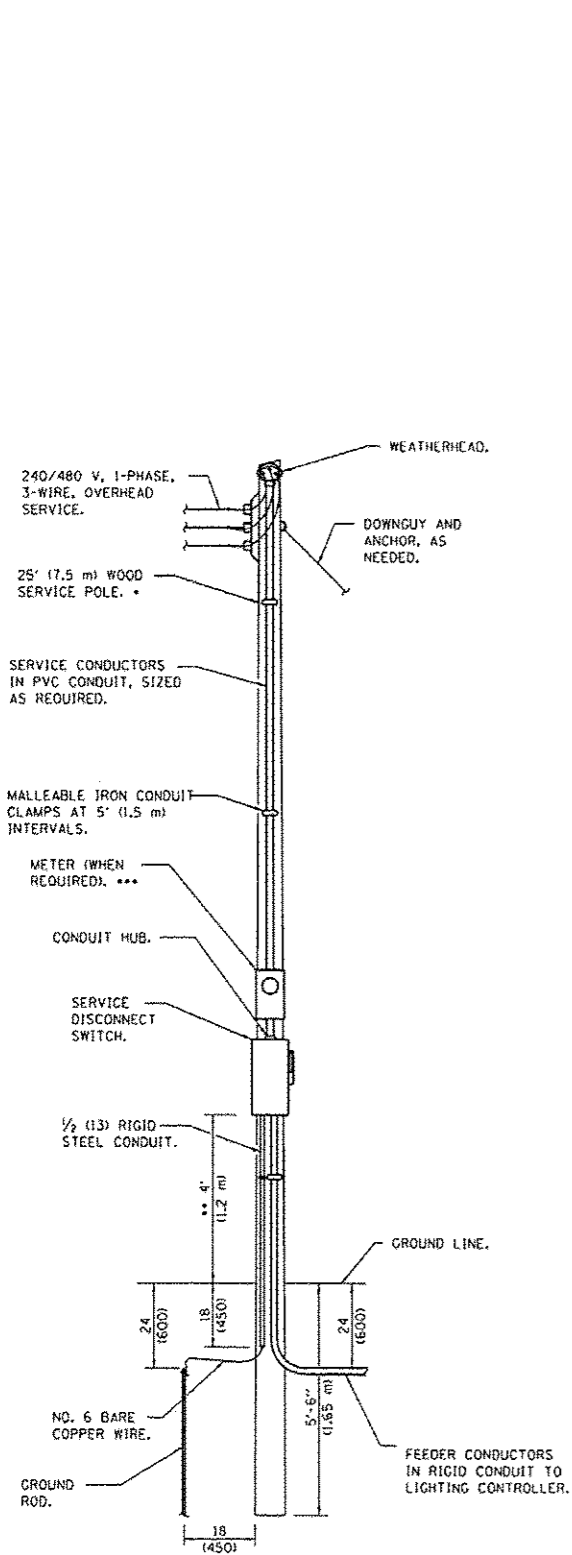

**ELECTRIC SERVICE INSTALLATION**

• SIZE LARGER AS NEEDED.  
 \*\* OR AS DIRECTED BY UTILITY COMPANY.  
 \*\*\* WHEN COLD SEQUENCING IS REQUIRED, PROVIDE A METER DISCONNECT SWITCH AS DIRECTED BY UTILITY COMPANY.

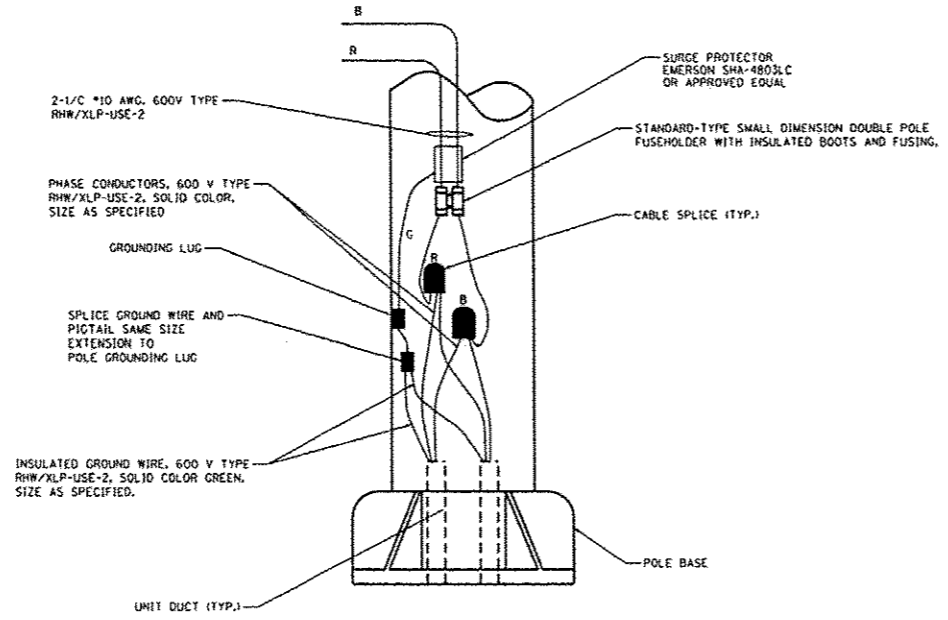

**POLE WIRING DETAIL**  
N.T.S.

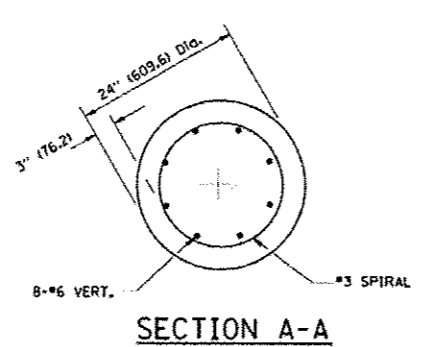

**SECTION A-A**

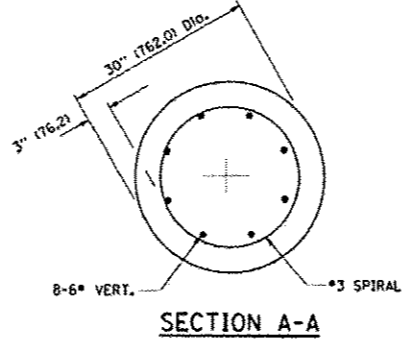

**SECTION A-A**

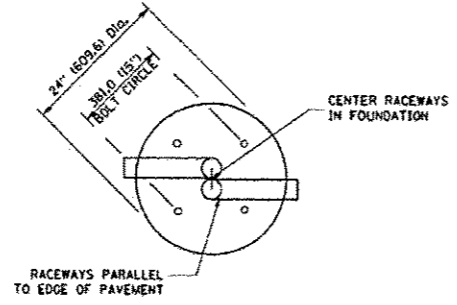

**TOP VIEW**

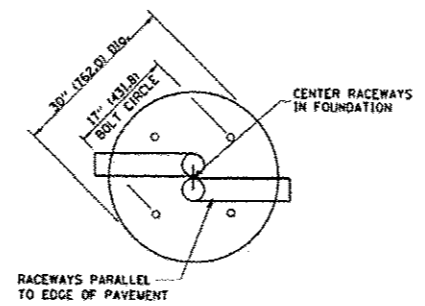

**TOP VIEW**

**FOUNDATION DETAIL**  
N.T.S.

**NOTES**

- ALL DIMENSIONS ARE IN INCHES (MILLIMETERS) UNLESS OTHERWISE SHOWN.
- THE ANCHOR RODS AND RACEWAYS SHALL BE PROPERLY SECURED IN PLACE BEFORE THE CONCRETE IS PLACED.
- THE FOUNDATION SHALL NOT PROTRUDE [REDACTED] ABOVE THE FINISHED GRADE WITHIN A 60 IN. (1.5 m) CHORD ACROSS THE FOUNDATION, WITH ANCHOR RODS INCLUDED. IN ACCORDANCE WITH AASHTO GUIDELINES, IF THE FOUNDATION HEIGHT, INCLUDING ANCHOR RODS, EXTENDS BEYOND THESE SPECIFIED LIMITS, THE FOUNDATION SHALL BE REPLACED AT THE CONTRACTOR'S EXPENSE. SEE FOUNDATION EXTENSION DETAIL.
- THE HOLE FOR THE FOUNDATION SHALL BE MADE BY DRILLING WITH AN AUGER, OF THE SAME DIAMETER AS THE FOUNDATION. IF SOIL CONDITIONS REQUIRE THE USE OF A LINER TO FORM THE HOLE, THE LINER SHALL BE WITHDRAWN AS THE CONCRETE IS DEPOSITED.
- THE TOP OF THE FOUNDATION SHALL BE CONSTRUCTED LEVEL. A LINER OR FORM SHALL BE USED TO PRODUCE A UNIFORM SMOOTH SIDE TO THE TOP OF THE FOUNDATION. FOUNDATION TOP SHALL BE CHAMFERED 3/4-IN. (20 mm).
- THE CONCRETE SHALL BE CLASS SI. CONCRETE SHALL CURE ACCORDING TO ARTICLE 1020.13 BEFORE LIGHT POLES ARE INSTALLED.
- THE ANCHOR ROD SHALL BE A HOOK ROD TYPE. COLD BENDING OF THE ANCHOR ROD WILL NOT BE ALLOWED. THE RADIUS OF THE HOOK BEND SHALL NOT BE LESS THAN 4 TIMES THE NOMINAL DIAMETER OF THE ANCHOR ROD. A TACK WELDED ANCHOR ROD MAY BE SUBSTITUTED WITH THE APPROVAL OF THE ENGINEER.
- THE ANCHOR RODS SHALL BE ACCORDING TO ASTM F1554 GRADE 725 (GRADE 105). NUTS SHALL BE HEXAGON NUTS ACCORDING TO ASTM A 194 2H OR ASTM A 563 DH, AND WASHERS SHALL BE ACCORDING TO ASTM F 436.
- ANCHOR RODS, NUTS AND WASHERS SHALL BE COMPLETELY GALVANIZED BY EITHER THE HOT-DIPPED PROCESS CONFORMING WITH AASHTO M 232, THE MECHANICAL PLATING METHOD CONFORMING TO AASHTO M 298, CLASS 50 WITH A MAXIMUM COATING THICKNESS OF 150 UM(6 MILS) OR THE ELECTROLYTIC PROCESS ACCORDING TO ASTM F 1136.
- THE ANCHOR RODS SHALL BE THREADED A MINIMUM OF 6 INCHES (150 mm) WITH A MINIMUM OF 3 INCHES (75 mm) OF THREADED ANCHOR ROD EMBEDDED IN THE FOUNDATION.
- ANCHOR RODS SHALL PROJECT 2 3/4" (69.9 mm) ABOVE THE TOP OF THE FOUNDATION, IF BREAKAWAY COUPLINGS ARE SPECIFIED, THE CONTRACTOR SHALL CAREFULLY COORDINATE THE ANCHOR ROD PROJECTION WITH THE INSTALLATION REQUIREMENTS OF THE BREAKAWAY COUPLINGS.
- THE CONTRACTOR SHALL USE A #3 SPIRAL AT 6" (152.4 mm) PITCH OR MAY SUBSTITUTE #3 TIES AT 12" (304.8 mm) O.C. WITH THE APPROVAL OF THE ENGINEER.
- THE CABLE TRENCHES AND FOUNDATION SHALL BE BACK FILLED AND COMPACTED AS SPECIFIED BEFORE THE LIGHT POLE IS ERECTED.
- THE RACEWAYS SHALL PROJECT 1" (25.4 mm) ABOVE THE TOP OF THE FOUNDATION.

| REVISIONS |             |      |
|-----------|-------------|------|
| REV. NO.  | DESCRIPTION | DATE |
|           |             |      |
|           |             |      |
|           |             |      |

### ROADWAY LUMINAIRE PERFORMANCE REQUIREMENTS (TYPICAL)

DMS55-400MH-SG3-HS (S0611152) - Copy.txt  
 IESNA:LM-63-2002  
 [ISSUEDATE] 15 November 2006  
 [TESTLAB] Spectra Lux Industries Inc.  
 [TEST] S0611152-R1  
 [MANUFAC] LUMEC  
 [LUMCAT] DMS55-400MH-SG3-HS  
 [LUMINATRE] Domus  
 [LAMP] (1) 400 MH ED-28  
 [LAMPDETAILS] M59 voltage=132V LCL=5  
 [BURNING] Horizontal (32,400 Lumens)  
 [REFLECTOR] White Formed Aluminum Specular Sides & Hammered Top  
 [LENS] Tempered Clear Flat Glass  
 [HOUSING] Die Cast Aluminum  
 [SKYPOSITION] HOR Fixed  
 [REPORTMODULE] IES LM-31-95 Roadway Report  
 [SUBREPORTMODULE] IES LM-31-95 Roadway Asymmetric Luminaire  
 [DISTRIBUTION] Type III, Medium, cutoff  
 TILT=NONE  
 1 32400 1.0 35 35 1 1 -1.2083 -1.2083 0.0000  
 1.0 1 435.38

|      |      |      |      |      |      |      |      |      |      |      |
|------|------|------|------|------|------|------|------|------|------|------|
| 50   | 55   | 60   | 62.5 | 65   | 67.5 | 70   | 72.5 | 75   | 77.5 | 80   |
| 80   | 82.5 | 85   | 87.5 | 90   | 95   | 105  | 115  | 125  | 135  | 145  |
| 145  | 155  | 165  | 175  | 180  | 0    | 5    | 15   | 25   | 35   | 45   |
| 57.5 | 60   | 62.5 | 65   | 67.5 | 70   | 72.5 | 75   | 77.5 | 80   | 82.5 |
| 82.5 | 85   | 87.5 | 90   | 92.5 | 95   | 105  | 115  | 125  | 135  | 145  |
| 4365 | 4924 | 5184 | 5299 | 5369 | 5342 | 5218 | 5129 | 5097 | 5089 | 5089 |
| 4874 | 4540 | 4251 | 3756 | 3350 | 3424 | 3180 | 2788 | 2481 | 2232 | 2000 |
| 16   | 15   | 15   | 15   | 0    | 0    | 0    | 0    | 0    | 0    | 0    |
| 4365 | 4908 | 5165 | 5271 | 5337 | 5350 | 5293 | 5089 | 5089 | 5089 | 5089 |
| 4842 | 4608 | 4330 | 3993 | 3308 | 2797 | 2465 | 2232 | 2000 | 1800 | 1600 |
| 1700 | 1180 | 550  | 219  | 118  | 57   | 29   | 20   | 20   | 20   | 20   |
| 17   | 16   | 16   | 16   | 0    | 0    | 0    | 0    | 0    | 0    | 0    |
| 4365 | 4874 | 5131 | 5251 | 5321 | 5424 | 5371 | 5193 | 5193 | 5193 | 5193 |
| 4959 | 4842 | 4786 | 4768 | 4299 | 3841 | 3606 | 2784 | 2784 | 2784 | 2784 |
| 2096 | 1296 | 728  | 618  | 220  | 59   | 31   | 21   | 21   | 21   | 21   |
| 19   | 18   | 18   | 17   | 0    | 0    | 0    | 0    | 0    | 0    | 0    |
| 4365 | 4812 | 5051 | 5233 | 5354 | 5401 | 5400 | 5441 | 5441 | 5441 | 5441 |
| 5551 | 5612 | 5880 | 5869 | 6514 | 6114 | 5253 | 4015 | 4015 | 4015 | 4015 |
| 2776 | 1657 | 423  | 215  | 110  | 59   | 33   | 23   | 23   | 23   | 23   |
| 21   | 20   | 19   | 19   | 0    | 0    | 0    | 0    | 0    | 0    | 0    |
| 4365 | 4740 | 4983 | 5270 | 5291 | 5399 | 5502 | 5764 | 5764 | 5764 | 5764 |
| 6111 | 6851 | 7755 | 7401 | 6299 | 5886 | 5093 | 4311 | 4311 | 4311 | 4311 |
| 4159 | 2972 | 1432 | 538  | 131  | 69   | 40   | 28   | 28   | 28   | 28   |
| 25   | 24   | 23   | 22   | 0    | 0    | 0    | 0    | 0    | 0    | 0    |
| 0    | 0    | 0    | 0    | 0    | 0    | 0    | 0    | 0    | 0    | 0    |
| 4365 | 4710 | 4954 | 5273 | 5288 | 5408 | 5544 | 5810 | 5810 | 5810 | 5810 |
| 6290 | 6985 | 7995 | 7598 | 6125 | 5648 | 4975 | 4564 | 4564 | 4564 | 4564 |
| 4564 | 3247 | 1731 | 790  | 147  | 72   | 42   | 29   | 29   | 29   | 29   |
| 26   | 24   | 23   | 23   | 0    | 0    | 0    | 0    | 0    | 0    | 0    |
| 0    | 0    | 0    | 0    | 0    | 0    | 0    | 0    | 0    | 0    | 0    |

Page 1

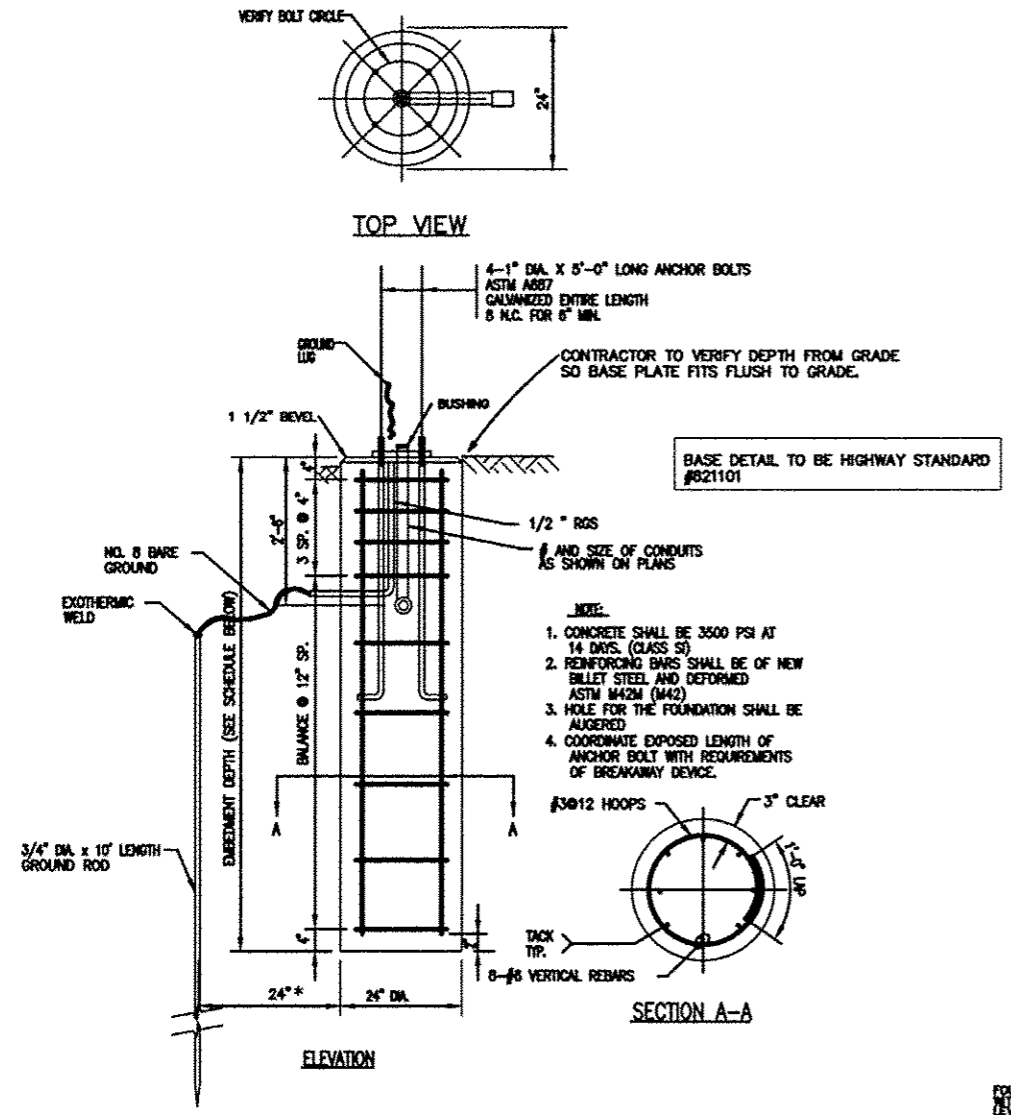

LIGHT UNIT POLE FOUNDATION (TYPICAL)  
 NO SCALE

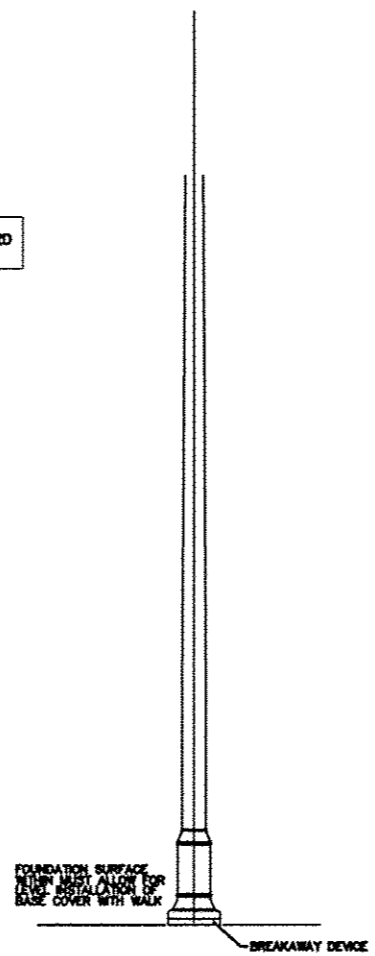

| SOIL CONDITIONS                      | DESIGN DEPTH "D" OF FOUNDATION |                     |
|--------------------------------------|--------------------------------|---------------------|
|                                      | SINGLE ARM POLE                | TWIN ARM POLE       |
| SOFT CLAY<br>Qu = 0.375 TON/SQ. FT.  | 11'-0"<br>(3.35 m)             | 12'-8"<br>(3.85 m)  |
| MEDIUM CLAY<br>Qu = 0.75 TON/SQ. FT. | 9'-0"<br>(2.74 m)              | 14'-10"<br>(4.52 m) |
| DENSE CLAY<br>Qu = 1.50 TON/SQ. FT.  | 7'-8"<br>(2.29 m)              | 8'-7"<br>(2.61 m)   |
| LOOSE SAND<br>B = 34"                | 9'-8"<br>(2.90 m)              | 10'-7"<br>(3.22 m)  |
| MEDIUM SAND<br>B = 37.5"             | 9'-0"<br>(2.74 m)              | 9'-10"<br>(2.99 m)  |
| DENSE SAND<br>B = 40"                | 8'-3"<br>(2.51 m)              | 9'-7"<br>(2.91 m)   |

| Symbol | Label | Qty | Catalog Number     | Description | Lamp             | File                              | Lumens | LLF  | Watts  |
|--------|-------|-----|--------------------|-------------|------------------|-----------------------------------|--------|------|--------|
| •      | B     | 78  | DMS55-400MH-SG3-HS | Lumec-Domus | (1) 400 MH ED-28 | DMS55-400MH-SG3-HS (S0611152).ies | 40000  | 0.81 | 435.38 |
| •      | C     | 1   | DMS55-400MH-SG3-HS | Lumec-Domus | (1) 400 MH ED-28 | DMS55-400MH-SG3-HS (S0611152).ies | 40000  | 0.81 | 435.38 |
| •      | D     | 13  | DMS55-400MH-SG3-HS | Lumec-Domus | (1) 400 MH ED-28 | DMS55-400MH-SG3-HS (S0611152).ies | 40000  | 0.81 | 435.38 |

| Description   | Symbol | Avg    | Max    | Min    | Max/Min | Avg/Min |
|---------------|--------|--------|--------|--------|---------|---------|
| Calc Zone #2  | +      | 1.2 fc | 2.8 fc | 0.0 fc | N/A     | N/A     |
| Calc Zone #5  | +      | 1.4 fc | 4.4 fc | 0.2 fc | 22.0:1  | 7.0:1   |
| Calc Zone #5  | +      | 0.9 fc | 2.7 fc | 0.1 fc | 27.0:1  | 9.0:1   |
| Calc Zone #8  | +      | 1.1 fc | 2.7 fc | 0.2 fc | 13.5:1  | 5.5:1   |
| Calc Zone #7  | +      | 1.0 fc | 3.3 fc | 0.1 fc | 33.0:1  | 10.0:1  |
| Calc Zone #8  | +      | 1.0 fc | 4.8 fc | 0.2 fc | 24.0:1  | 5.0:1   |
| Calc Zone #10 | +      | 1.2 fc | 4.7 fc | 0.1 fc | 47.0:1  | 12.0:1  |
| Stat Zone #3  | X      | 1.6 fc | 3.2 fc | 0.3 fc | 10.7:1  | 5.3:1   |

| REV. NO. | DESCRIPTION | DATE |
|----------|-------------|------|
|          |             |      |
|          |             |      |
|          |             |      |



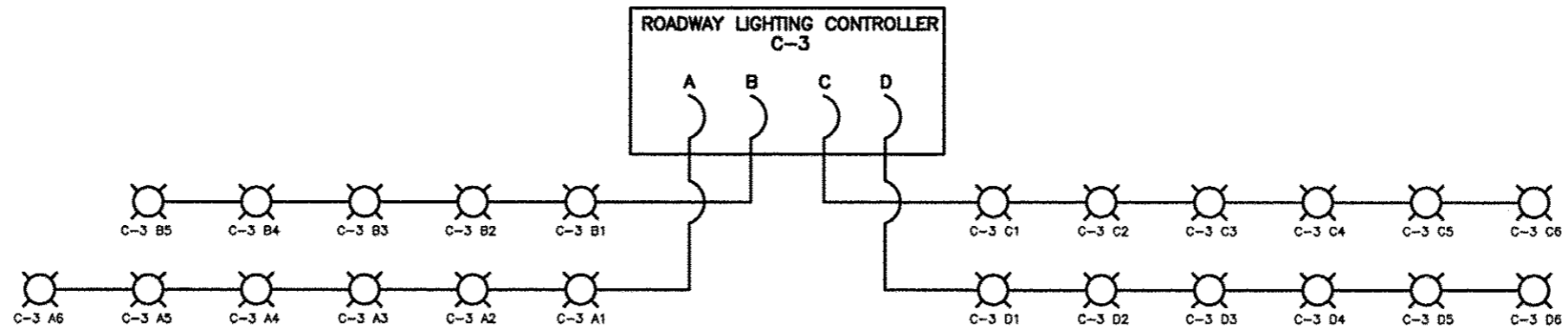
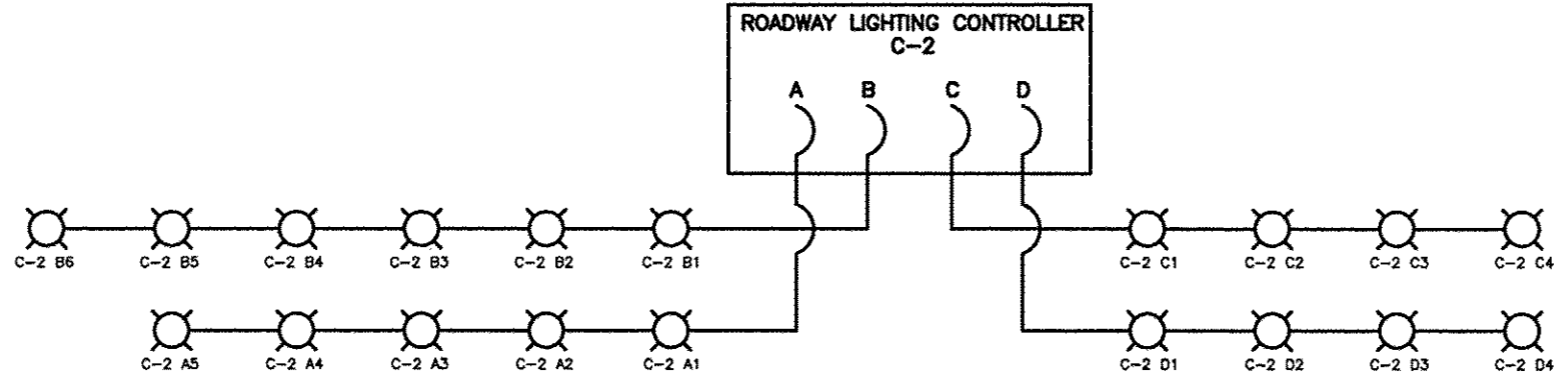
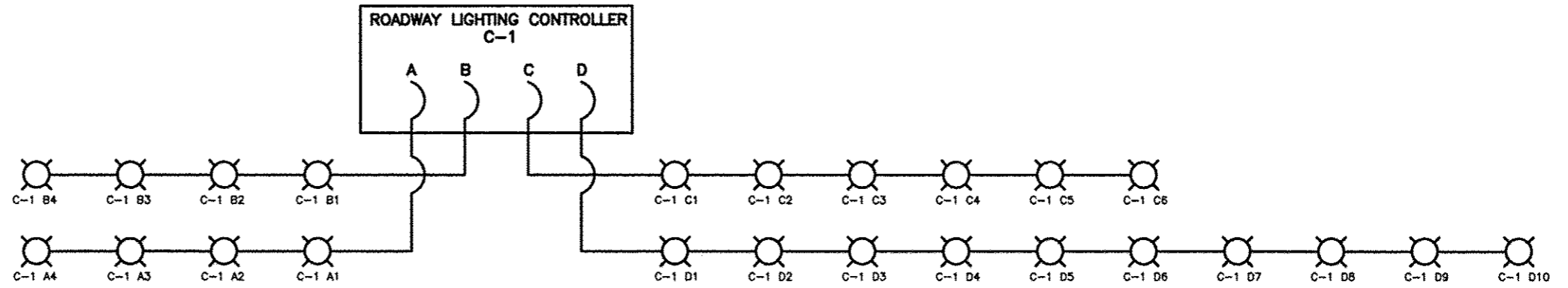

Bench Mark: Arrow Bolt on Fire Hydrant  
Station 144+49 - 166' Rt.  
Elev.=736.01

Existing Structure: SN 101-6087 built in 1956 as a three-barrel 10.5'-13.0'-10.5'x6' reinforced concrete box culvert. The structure is approximately 36'-8" long measured at right angles at the centerline of the culvert. One lane of traffic in each direction to be maintained utilizing stage construction.

**HIGHWAY CLASSIFICATION**

Harrison Avenue FA Route 525  
Functional Class: Regional Arterial  
ADT: 12,600 (2015) 15,850 (2035)  
ADTT: 951  
DHFV: 1,585  
Design Speed 45 mph  
Posted Speed 40 mph

**LOADING HL-93**

Allow 50#/sq. ft. for future wearing surface

**DESIGN STRESSES**

FIELD UNITS: CONCRETE BOX CULVERT  
f'c = 3,500 psi (Class SI Concrete)  
fy = 60,000 psi (Reinforcement)

FIELD UNITS: CONCRETE SUPERSTRUCTURE  
f'c = 4,000 psi (Class BS Concrete)  
fy = 60,000 psi (Reinforcement)

**DESIGN SPECIFICATIONS**

AASHTO LRFD Bridge Design Specifications,  
6th Edition 2012 & 2013 Interim Revisions

**DESIGN SCOUR ELEVATION TABLE**

| Design Scour    | Upstream | Downstream |
|-----------------|----------|------------|
| Elevation (Ft.) | 722.21   | 722.09     |

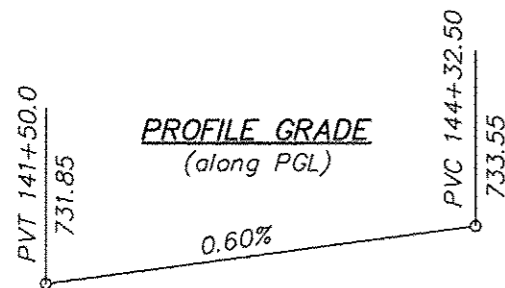

**WATERWAY INFORMATION**

|  |              |
|--|--------------|
| Drainage Area.....                           | 4.26 Sq. Mi. |
| Existing Opening (Bridge)..... (** Yr.)..... | 185 Sq. Ft.  |
| Required Opening..... (** Yr.).....          | 223 Sq. Ft.  |
| Proposed Opening (Bridge)..... (** Yr.)..... | 223 Sq. Ft.  |
| Design Discharge..... (** Yr.).....          | 1325 C.F.S.  |
| Existing Created Head..... (** Yr.).....     | 1.92 Ft.     |
| Proposed Created Head..... (** Yr.).....     | 1.60 Ft.     |
| ** Existing Channel Capacity                 |              |

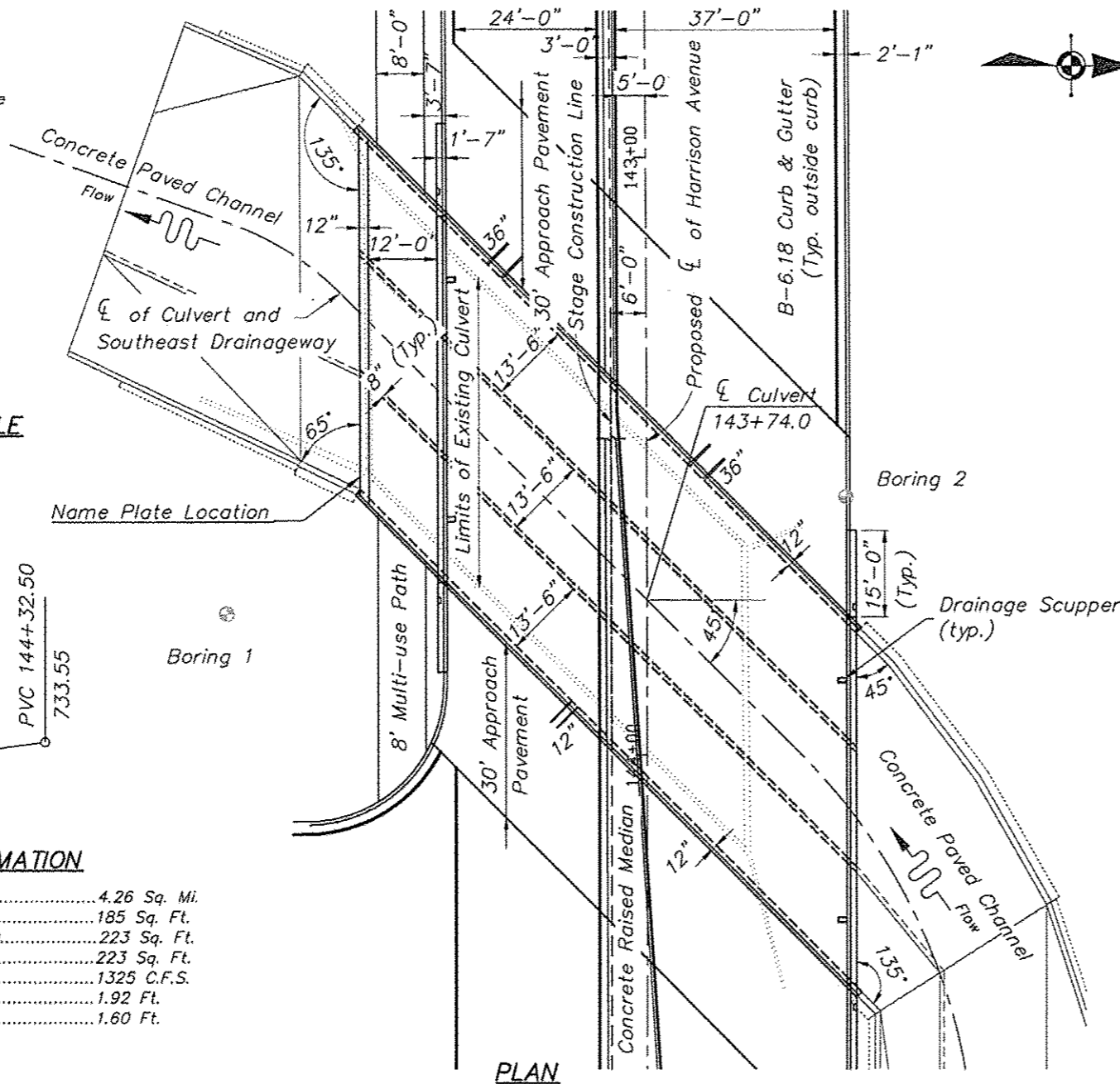
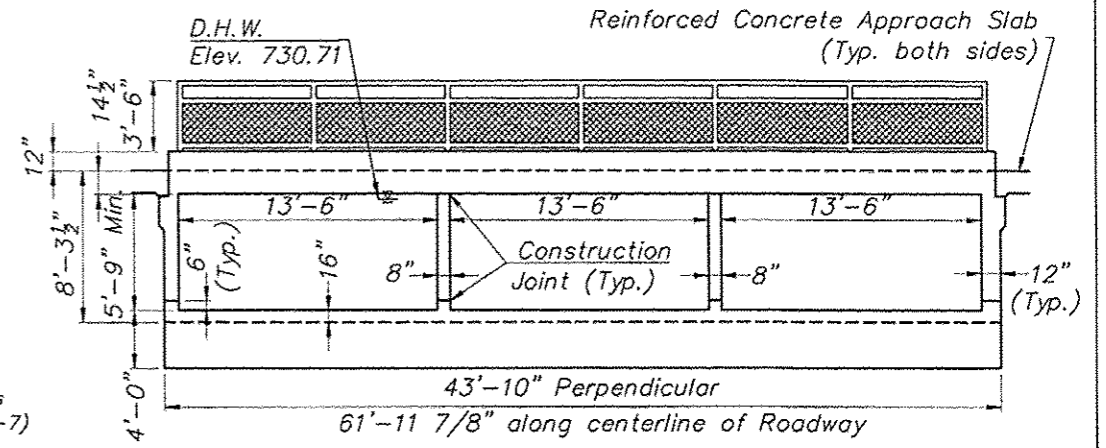
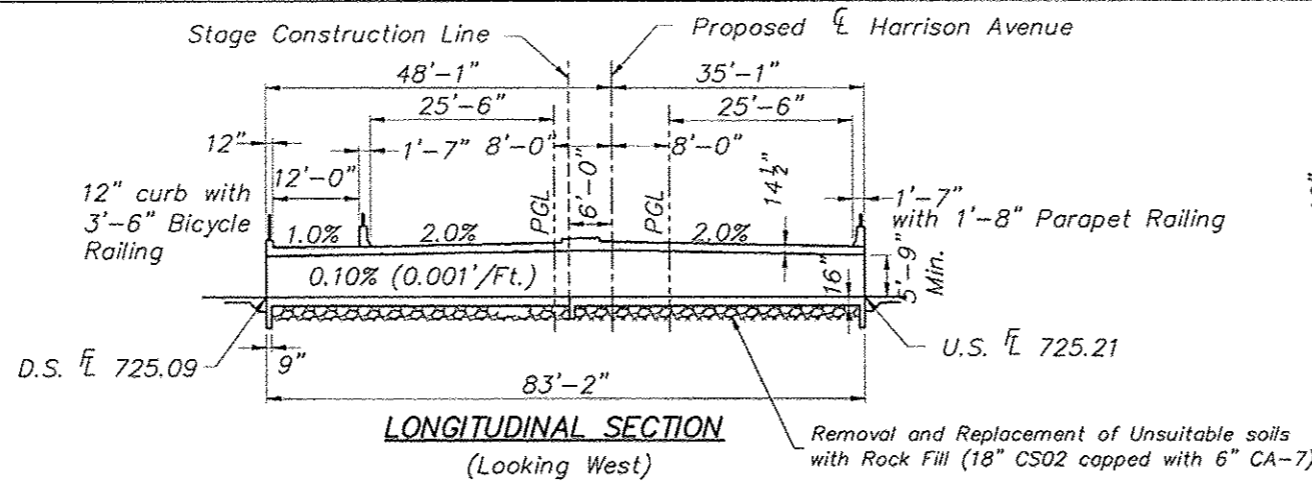

**INDEX OF SHEETS**

1. General Plan and Elevation
2. Bill of Material and Notes
3. Plan Layout
4. Stage Construction
5. Bottom Slab
6. Top Slab
7. Section Through Barrel
8. Culvert Wall Openings
9. Culvert Details
10. Deck Drain Details
11. East Approach Slab Elevations
12. West Approach Slab Elevations
13. Culvert Approach Slab
14. Culvert Approach Slab Details
15. Parapet Details and Rail Post Spacing
16. Bicycle Railing Details
17. Drainage Scupper, DS-11
18. Bar Splicer Assembly
19. Temporary Barrier

SOUTHEAST DRAINAGE WAY  
BUILT 201\_ BY  
CITY OF ROCKFORD  
SEC. 01-00509-00-RP  
F.A. RT. 525 STA. 143+74.0  
STR. NO. 101-6105 LOADING HL-93

**NAME PLATE**

See Std. 515001

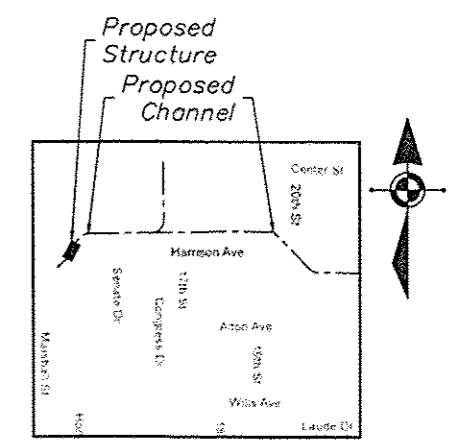

Section 36, Township 44 North, Range 1 East  
of the 3rd Principal Meridian

**LOCATION SKETCH**

**GENERAL PLAN & ELEVATION  
HARRISON AVENUE  
OVER THE SOUTHEAST DRAINAGE WAY  
CITY OF ROCKFORD  
WINNEBAGO COUNTY  
STATION 143+74.0  
STRUCTURE No. 101-6105**

"I certify that to the best of my knowledge, information and belief, this culvert design is structurally adequate for the design loading shown on the plans. The design is an economical one for the style of structure and complies with the requirements of the specified 'AASHTO LRFD Bridge Design Specifications'."

*Ali A. Gharami*  
ILLINOIS STRUCTURAL ENGINEER NO. 081-005060  
EXPIRES 11/30/2016

6/11/15  
Dated

Sheet 1 of 19

**FEHR GRAHAM**  
ENGINEERING & ENVIRONMENTAL  
ILLINOIS DESIGN FIRM NO. 194-003525  
©2013 FEHR-GRAHAM

ILLINOIS  
IOWA  
WISCONSIN

**McClure**  
Engineering Associates, Inc.  
1202 Argus Drive  
Rockford, Illinois 61107-6837  
(616) 398-2332 FAX (616) 398-2496  
Design Firm License: Illinois 104-000816  
Copyright 2013 By McClure Engineering Associates, Inc.

PROJECT AND LOCATION:  
HARRISON AVENUE  
RECONSTRUCTION 2012  
PHASE 1  
ROCKFORD, ILLINOIS

DRAWN BY: JWH  
APPROVED BY: CTB  
DATE: 6/12/15  
SCALE: NTS

| REV. NO. | DESCRIPTION                     | DATE    |
|----------|---------------------------------|---------|
| 1        | Wearing surf. and Railing notes | 1-13-13 |

DRAWING:  
GENERAL PLAN & ELEVATION  
STRUCTURE NO. 101-6105

JOB NUMBER:  
11-128  
SHEET NUMBER:  
374 of 588

**BILL OF MATERIAL**

(for Culvert Only)

| Bar                        | No. | Size | Length  | Shape   |
|----------------------------|-----|------|---------|---------|
| a (E)                      | 330 | #7   | 43'-9"  | —       |
| a <sub>1</sub> (E)         | 672 | #7   | 33'-0"  | —       |
| a <sub>2</sub> (E)         | 330 | #7   | 23'-9"  | —       |
| a <sub>3</sub> (E)         | 44  | #6   | 6'-6"   | —       |
| a <sub>4</sub> (E)         | 32  | #5   | 1'-6"   | —       |
| d (E)                      | 138 | #5   | 5'-7"   | U       |
| d <sub>1</sub> (E)         | 138 | #5   | 8'-5"   | V       |
| d <sub>2</sub> (E)         | 84  | #4   | 5'-6"   | L       |
| d <sub>3</sub> (E)         | 236 | #5   | 4'-0"   | L       |
| e (E)                      | 42  | #4   | 20'-0"  | —       |
| e <sub>1</sub> (E)         | 4   | #8   | 33'-2"  | —       |
| e <sub>2</sub> (E)         | 4   | #4   | 31'-6"  | —       |
| h (E)                      | 88  | #5   | 57'-8"  | —       |
| h <sub>1</sub> (E)         | 88  | #6   | 57'-8"  | —       |
| h <sub>2</sub> (E)         | 50  | #5   | 57'-8"  | —       |
| h <sub>3</sub> (E)         | 50  | #5   | 59'-1"  | —       |
| h <sub>4</sub> (E)         | 88  | #6   | 59'-1"  | —       |
| h <sub>5</sub> (E)         | 88  | #5   | 59'-1"  | —       |
| h <sub>6</sub> (E)         | 12  | #5   | 32'-2"  | —       |
| h <sub>7</sub> (E)         | 6   | #5   | 20'-0"  | —       |
| h <sub>8</sub> (E)         | 4   | #6   | 32'-5"  | —       |
| h <sub>9</sub> (E)         | 6   | #8   | 43'-2"  | —       |
| h <sub>10</sub> (E)        | 6   | #8   | 23'-9"  | —       |
| h <sub>11</sub> (E)        | 10  | #4   | 33'-4"  | —       |
| h <sub>12</sub> (E)        | 10  | #5   | 5'-6"   | —       |
| h <sub>13</sub> (E)        | 10  | #5   | 4'-4"   | —       |
| h <sub>14</sub> (E)        | 9   | #5   | 3'-0"   | —       |
| h <sub>15</sub> (E)        | 7   | #5   | 1'-8"   | —       |
| s (E)                      | 123 | #4   | 6'-0"   | □       |
| s <sub>1</sub> (E)         | 236 | #4   | 3'-4"   | □       |
| s <sub>2</sub> (E)         | 60  | #4   | 4'-1"   | □       |
| v (E)                      | 236 | #5   | 2'-0"   | —       |
| v <sub>1</sub> (E)         | 476 | #5   | 6'-0"   | —       |
| v <sub>2</sub> (E)         | 708 | #5   | 5'-4"   | —       |
| v <sub>3</sub> (E)         | 244 | #5   | 5'-0"   | —       |
| v <sub>4</sub> (E)         | 4   | #5   | 7'-4"   | —       |
| z (E)                      | 88  | #5   | 3'-1"   | —       |
| z <sub>1</sub> (E)         | 16  | #5   | 7'-6"   | —       |
| Concrete Superstructure    |     |      | Cu. Yd. | 249.5   |
| Concrete Box Culvert       |     |      | Cu. Yd. | 364.7   |
| Reinforcement Bars (Epoxy) |     |      | Pound   | 140,344 |
| Bar Splicers               |     |      | Each    | 226     |

**SUMMARY OF QUANTITIES**

(Includes Culvert and Approach Pavement)

| PAY Code | Description  | Units | Quantity |
|----------|--|-------|----------|
| 20700220 | POROUS GRANULAR EMBANKMENT   | CU YD | 365      |
| 42001200 | PAVEMENT FABRIC  | SQ YD | 464      |
| 42001420 | BRIDGE APPROACH PAVEMENT CONNECTOR (PCC)                             | SQ YD | 464      |
| 50200100 | STRUCTURE EXCAVATION   | CU YD | 650      |
| 50200450 | REMOVAL AND DISPOSAL OF UNSUITABLE MATERIALS FOR STRUCTURES          | CU YD | 435      |
| 50300255 | CONCRETE SUPERSTRUCTURE  | CU YD | 477.2    |
| 50300260 | BRIDGE DECK GROOVING   | SQ YD | 1,210    |
| 50300300 | PROTECTIVE COAT  | SQ YD | 1,622    |
| 50800205 | REINFORCEMENT BARS (EPOXY COATED)                                    | POUND | 207,811  |
| 50800515 | BAR SPLICERS   | EACH  | 528      |
| 50901720 | BICYCLE RAILING  | FOOT  | 61       |
| 50901750 | PARAPET RAILING  | FOOT  | 175      |
| 51500100 | NAME PLATE   | EACH  | 1        |
| 54003000 | CONCRETE BOX CULVERTS  | CU YD | 467.3    |
| 59100100 | GEOCOMPOSITE WALL DRAIN  | SQ YD | 170      |
| 81022100 | CONDUIT ENCASED IN CONCRETE, 2" DIA., PVC                            | FOOT  | 130      |
| 81301290 | JUNCTION BOX, STAINLESS STEEL, EMBEDDED IN STRUCTURE, 12" X 12" X 6" | EACH  | 4        |
| Z0018002 | DRAINAGE SCUPPERS, DS-11   | EACH  | 4        |
| Z0054500 | ROCK FILL  | TON   | 620      |
| Z0073002 | TEMPORARY SOIL RETENTION SYSTEM                                      | SQ FT | 215      |
| Z0073400 | TEMPORARY SUPPORT SYSTEM   | EACH  | 3        |

**GENERAL NOTES**

- Precast Alternate is not allowed.
- Reinforcement Bars shall conform to the requirements of ASTM A 706, Grade 60.
- Reinforcement bars designated (E) shall be epoxy coated.
- Bars noted thus, 3x2-#5 indicates 3 lines of bars with 2 lengths per line.
- The depth of Removal and Disposal of unsuitable materials for structures shall be determined in the field by the Engineer. The quantity shown on the plans is based on an assumed thickness of 24 inches.
- The capping material designated CA-7 below the bottom slab shall be paid for as Rock Fill.
- All construction joints shall be bonded.
- Exposed edges shall have a 3/4" x 45° chamfer except as shown otherwise. Chamfers on vertical edges shall be continued a minimum of one foot below finished ground level. Exposed faces of curb and parapet walls shall be given a rubbed finish in accordance with Article 503.15(b) of the Standard Specifications. The cost shall be included in the cost for Concrete Box Culverts.
- A waterproofing membrane system shall be applied to the bonded construction joint on the outside walls between Stage 1 and Stage 2. This work shall be incidental to Concrete Box Culvert.
- Reinforcement bars shall have a minimum length of lap as shown on the plans. Radius bars shall be factory bent and delivered to the site with the approximate radius. Field bending will only be allowed to achieve form clearance.
- All bars that are field cut shall be coated with epoxy paint where bare steel is exposed. The method of protection is given in Section 508.04 of the Standard Specifications.
- Bar intersections shall be tied in accordance with Section 508.05 of the Standard Specifications.
- The concrete raised median shall be poured monolithically in Stage 2 or 3 of Construction. Bars set in the Top Slab shall be protected from damage and environment until they are incorporated into the work.
- Walls, Bottom Slab, Approach Footing, and Toe Walls will be paid as Concrete Box Culvert. Top Slab, Parapet Walls, Curb, and Approach Slab will be paid as Concrete Superstructure.
- Standard 631031 Traffic Barrier Terminal shall be attached to parapet walls.
- The Contractor shall remove or abandon the existing utilities incorporated into the bottom slab of the current structure in accordance with the Standard Specifications. The Contractor shall salvage the existing steel plates and coordinate pick-up by the City of Rockford. The Contractor shall be responsible for the removal and disposal of the existing wood shoring after the temporary support system has been installed. The cost to perform these items of work shall be included in the cost for Removal of Existing Structures.
- Removal and Disposal of Unsuitable Materials is an estimated quantity to be used at the discretion of the Engineer. All or none of it may be used to remove wet or organic soils below footings and foundations.

**BILL OF MATERIAL AND NOTES**  
**HARRISON AVENUE**  
**OVER THE SOUTHEAST DRAINAGE WAY**  
**CITY OF ROCKFORD**  
**WINNEBAGO COUNTY**  
**STATION 143+74.0**  
**STRUCTURE No. 101-6105**

BENCH MARK: Arrow Bolt on Fire Hydrant  
Station 144+49 166' Rt.  
Elev.=736.01

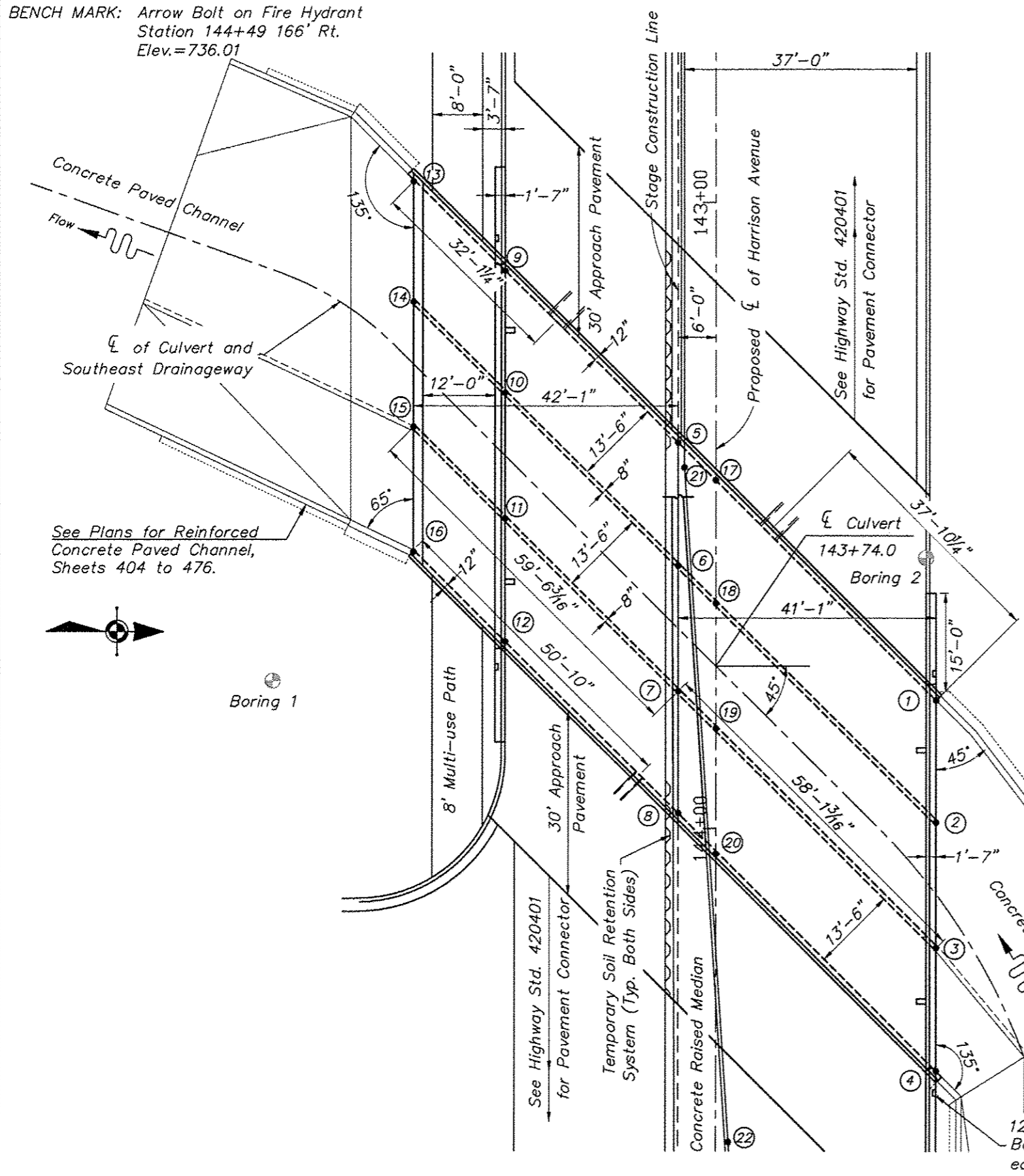

| TOP AND BOTTOM SLAB LAYOUT |              |           |            |                       |                          |                          |
|----------------------------|--------------|-----------|------------|-----------------------|--------------------------|--------------------------|
| PGL                        | Point Number | Station   | Offset     | Top of Top Slab Elev. | Bottom of Top Slab Elev. | Top of Bottom Slab Elev. |
| 733.24                     | 1            | 143+79.50 | 35.08' Lt. | 732.70                | 731.49                   | 725.21                   |
| 733.35                     | 2            | 143+99.06 | 35.08' Lt. | 732.81                | 731.60                   | 725.21                   |
| 733.47                     | 3            | 144+19.10 | 35.08' Lt. | 732.93                | 731.72                   | 725.21                   |
| 733.58                     | 4            | 144+38.66 | 35.08' Lt. | 733.04                | 731.83                   | 725.21                   |
| 732.99                     | 5            | 143+38.42 | 6.00' Rt.  | 733.03                | 731.82                   | 725.15                   |
| 733.11                     | 6            | 143+57.98 | 6.00' Rt.  | 733.15                | 731.94                   | 725.15                   |
| 733.23                     | 7            | 143+78.02 | 6.00' Rt.  | 733.27                | 732.06                   | 725.15                   |
| 733.34                     | 8            | 143+97.58 | 6.00' Rt.  | 733.38                | 732.17                   | 725.15                   |
| 732.82                     | 9            | 143+10.92 | 33.50' Rt. | 732.31                | 731.10                   | 725.11                   |
| 732.94                     | 10           | 143+30.48 | 33.50' Rt. | 732.43                | 731.22                   | 725.11                   |
| 733.06                     | 11           | 143+50.52 | 33.50' Rt. | 732.55                | 731.34                   | 725.11                   |
| 733.18                     | 12           | 143+70.08 | 33.50' Rt. | 732.67                | 731.46                   | 725.11                   |
| 732.73                     | 13           | 142+96.60 | 48.08' Rt. | 732.08                | 730.87                   | 725.09                   |
| 732.86                     | 14           | 143+15.90 | 48.08' Rt. | 732.20                | 730.99                   | 725.09                   |
| 732.98                     | 15           | 143+35.93 | 48.08' Rt. | 732.32                | 731.11                   | 725.09                   |
| 733.09                     | 16           | 143+55.76 | 48.08' Rt. | 732.43                | 731.22                   | 725.09                   |
| 733.03                     | 17           | 143+44.42 | 0.00' Rt.  | 733.19                | 731.98                   | 725.16                   |
| 733.14                     | 18           | 143+63.98 | 0.00' Rt.  | 733.30                | 732.09                   | 725.16                   |
| 733.26                     | 19           | 143+84.02 | 0.00' Rt.  | 733.42                | 732.21                   | 725.16                   |
| 733.38                     | 20           | 144+03.58 | 0.00' Rt.  | 733.54                | 732.33                   | 725.16                   |
| 733.01                     | 21           | 143+42.38 | 5.00' Lt.  | 733.11                | N/A                      | N/A                      |
| 733.71                     | 22           | 145+50.00 | 2.00' Lt.  | N/A                   | N/A                      | N/A                      |

Note: Stationing and Elevation for inside walls are to the wall centerlines. Stationing and Elevations for outside walls are to the inside face of wall.

See Plans for Reinforced Concrete Paved Channel, Sheets 404 to 476.

**PLAN LAYOUT  
HARRISON AVENUE  
OVER THE SOUTHEAST DRAINAGE WAY  
CITY OF ROCKFORD  
WINNEBAGO COUNTY  
STATION 143+74.0  
STRUCTURE No. 101-6105**

Sheet 3 of 19

**FEHR GRAHAM**  
ENGINEERING & ENVIRONMENTAL  
ILLINOIS DESIGN FIRM NO. 184-903525  
©2013 FEHR-GRAHAM

ILLINOIS  
IOWA  
WISCONSIN

**McClure**  
Engineering Associates, Inc.  
7282 Argus Drive  
Rockford, Illinois 61107-6837  
TEL (815) 398-2332 FAX (815) 398-2498  
Design Firm License: Illinois 184-000816  
Copyright 2013 By McClure Engineering Associates, Inc.

PROJECT AND LOCATION:  
HARRISON AVENUE  
RECONSTRUCTION 2012  
PHASE 1  
ROCKFORD, ILLINOIS

DRAWN BY: JWH  
APPROVED BY: CTB  
DATE: 6/12/15  
SCALE: 1"=10'

| REVISIONS |             |      |
|-----------|-------------|------|
| REV. NO.  | DESCRIPTION | DATE |
|           |             |      |
|           |             |      |
|           |             |      |
|           |             |      |

DRAWING:  
PLAN LAYOUT  
STRUCTURE NO. 101-6105

JOB NUMBER:  
11-128  
SHEET NUMBER:  
376 of 588

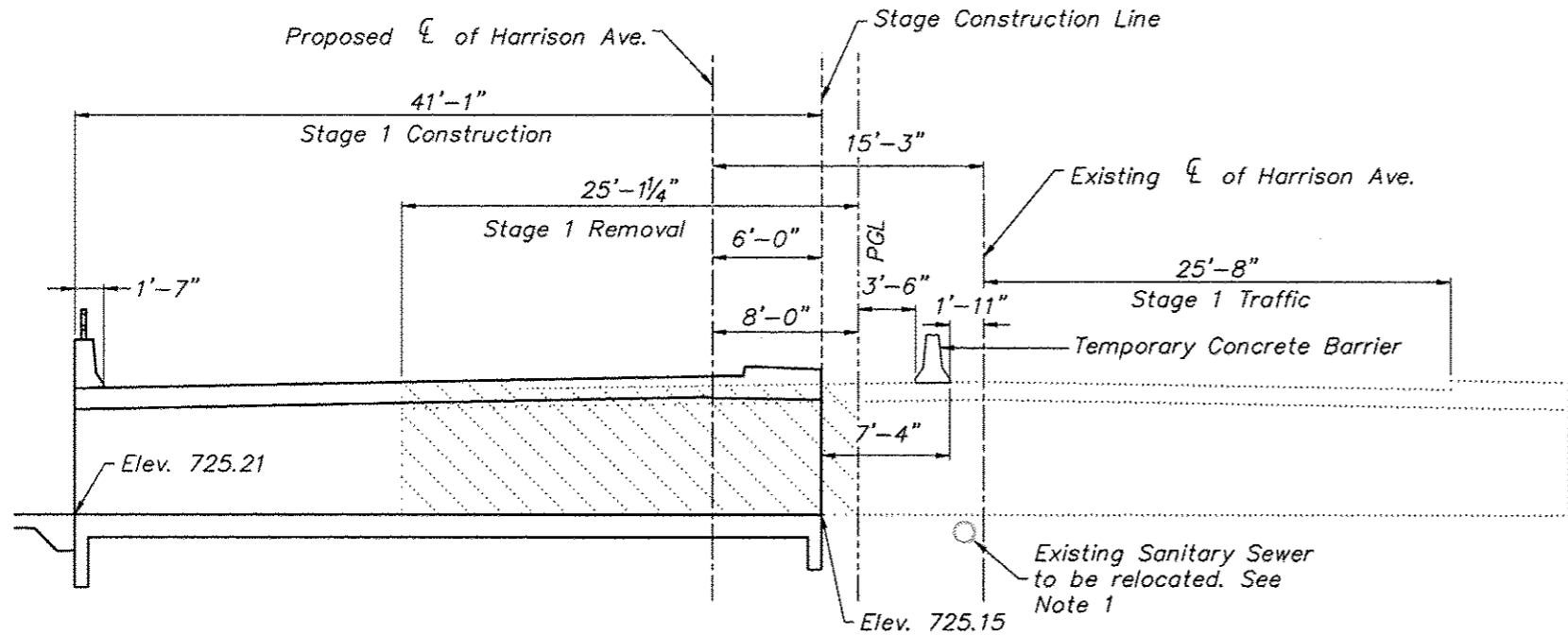

**STAGE 1 REMOVAL AND CONSTRUCTION**  
(Looking Upstation)

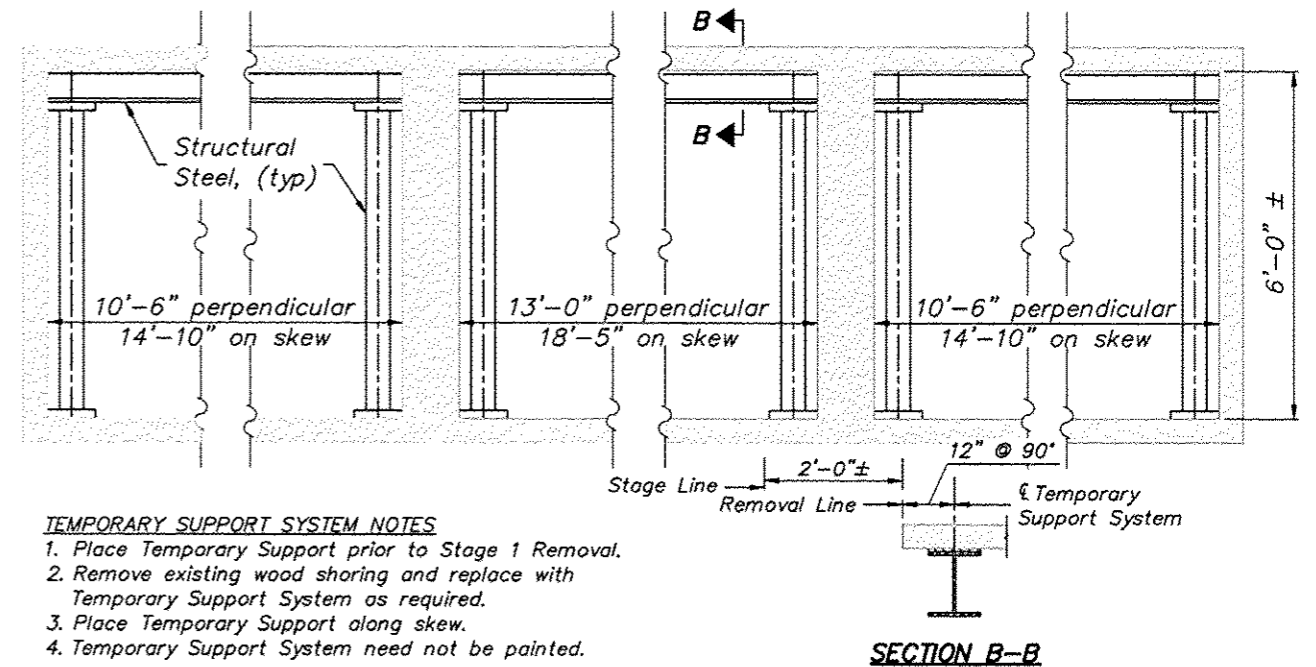

- TEMPORARY SUPPORT SYSTEM NOTES**
1. Place Temporary Support prior to Stage 1 Removal.
  2. Remove existing wood shoring and replace with Temporary Support System as required.
  3. Place Temporary Support along skew.
  4. Temporary Support System need not be painted.

**TEMPORARY SUPPORT SYSTEM**

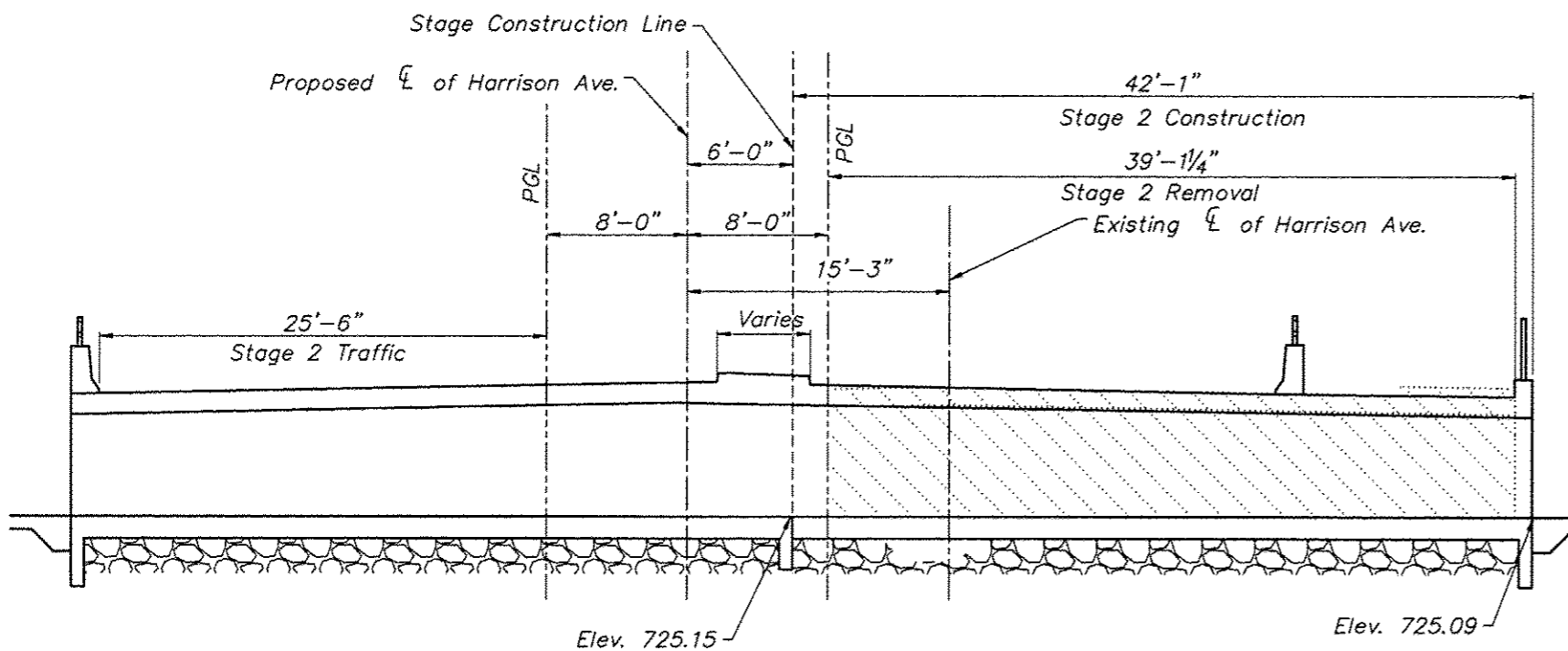

**STAGE 2 REMOVAL AND CONSTRUCTION**  
(Looking Upstation)

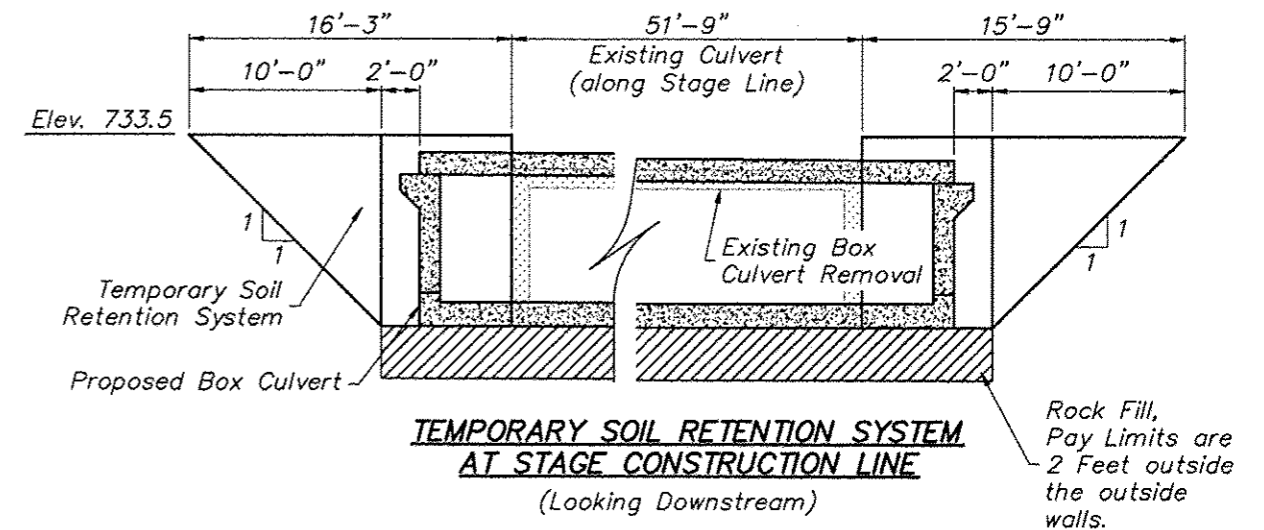

- TEMPORARY SOIL RETENTION SYSTEM NOTES**
1. Existing 12" VCP Sanitary Sewer is cast into the bottom of the existing box culvert. Care shall be exercised in removal and relocating of the sewer. Call RRWRD 48 hours before commencing work in this Stage removal. Sanitary sewer will be lowered as part of this project.
  2. Shoring will be required in the south barrels of the existing culvert prior to removal of the north side. This item will be paid as Temporary Support System. See the Special Provisions for submittal requirements. The Contractor shall maintain drainage flows throughout the period of construction.
  3. Temporary Soil Retention System shall be provided by the Contractor. See the Special Provisions for submittal requirements. A portion of the Temporary Soil Retention System will be removed for Stage II construction. No additional compensation will be allowed for this adjustment.

**STAGE CONSTRUCTION  
HARRISON AVENUE  
OVER THE SOUTHEAST DRAINAGE WAY  
CITY OF ROCKFORD  
WINNEBAGO COUNTY  
STATION 143+74.0  
STRUCTURE No. 101-6105**

| REVISIONS |             |      |
|-----------|-------------|------|
| REV. NO.  | DESCRIPTION | DATE |
|           |             |      |
|           |             |      |
|           |             |      |

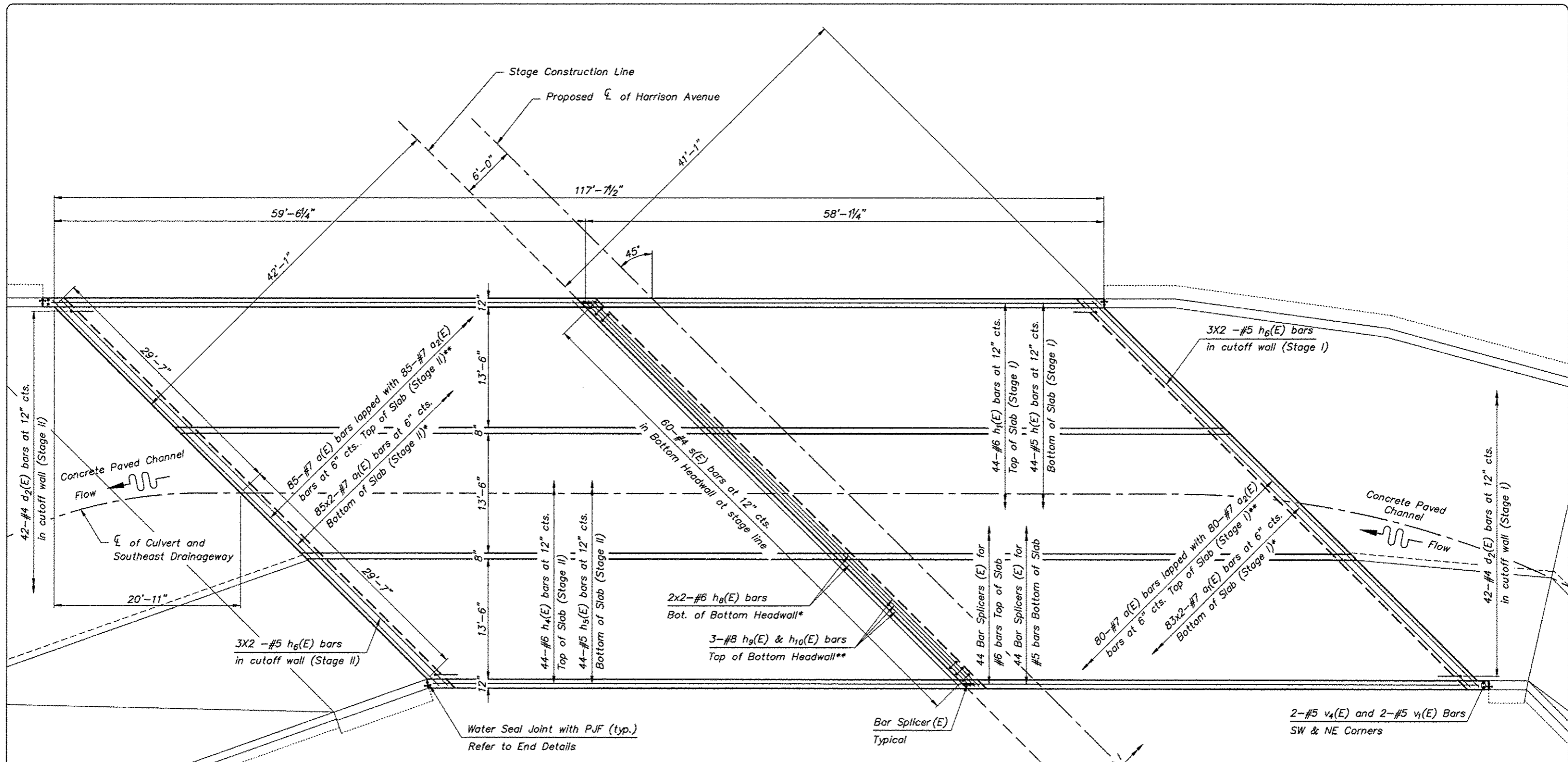

**PLAN BOTTOM SLAB**



**MINIMUM BAR LAP**

- #4 bar - 2'-1"
- #5 bar - 2'-7"
- #6 bar - 3'-1"
- #7 bar - 4'-2"
- #8 bar - 5'-5"
- #9 bar - 6'-10"

\* Lap at Center  
 \*\* Alternate lap over East and West inside walls.

**BOTTOM SLAB  
 HARRISON AVENUE  
 OVER THE SOUTHEAST DRAINAGE WAY  
 CITY OF ROCKFORD  
 WINNEBAGO COUNTY  
 STATION 143+74.0  
 STRUCTURE No. 101-6105**

Sheet 5 of 19

**FEHR GRAHAM**

ENGINEERING & ENVIRONMENTAL  
 ILLINOIS DESIGN FIRM NO. 184-983585

ILLINOIS  
 IOWA  
 WISCONSIN

**McClure**  
 Engineering Associates, Inc.  
 7262 Argus Drive Rockford, Illinois 61107-5837  
 (616) 398-2332 FAX (815) 398-2496  
 Design Firm License: Illinois 184-000816  
 Copyright 2013 By McClure Engineering Associates, Inc.

PROJECT AND LOCATION  
 HARRISON AVENUE  
 RECONSTRUCTION 2012  
 PHASE 1  
 ROCKFORD, ILLINOIS

DRAWN BY: JWH  
 APPROVED BY: CTB  
 DATE: 6/12/15  
 SCALE: NTS

| REVISIONS |             |      |
|-----------|-------------|------|
| REV. NO.  | DESCRIPTION | DATE |
|           |             |      |
|           |             |      |
|           |             |      |

DRAWING  
 BOTTOM SLAB  
 STRUCTURE NO. 101-6105

JOB NUMBER  
 11-128  
 SHEET NUMBER  
 378 of 588

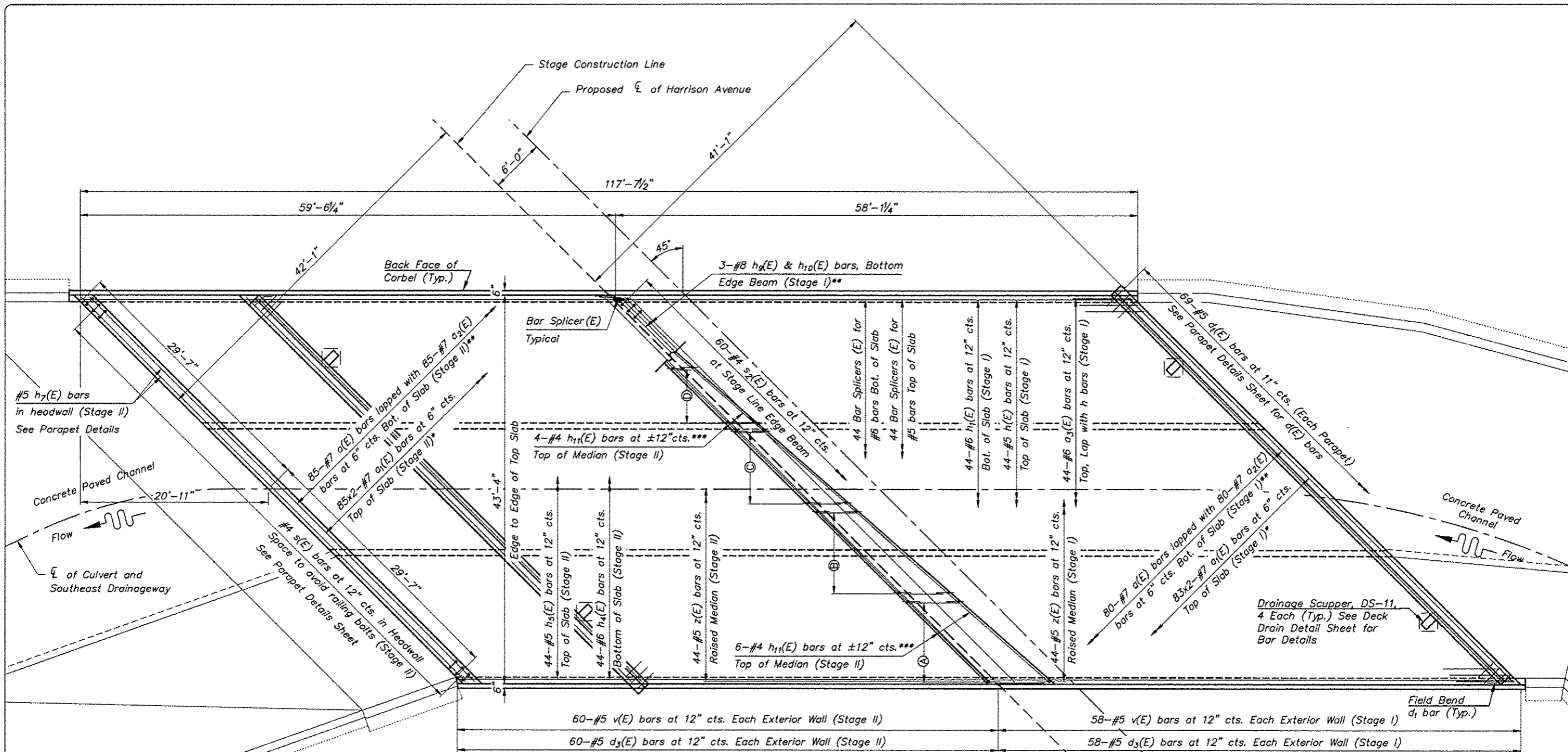

\* Lap at Center  
 \*\* Alternate lap over East and West inside walls  
 \*\*\* Field bend and lap with h<sub>11</sub> bars from opposite end when necessary

**MINIMUM BAR LAP**

- #4 bar - 2'-1"
- #5 bar - 2'-7"
- #6 bar - 3'-1"
- #7 bar - 4'-2"
- #8 bar - 5'-5"
- #9 bar - 6'-10"

**STAGE II MEDIAN BARS**

- (A) 10-#5 h<sub>12</sub>(E) bars, Lap with Z bars
- (B) 10-#5 h<sub>13</sub>(E) bars, Lap with Z bars
- (C) 9-#5 h<sub>14</sub>(E) bars, Lap with Z bars
- (D) 7-#5 h<sub>15</sub>(E) bars, Lap with Z bars

**PLAN TOP SLAB**



Note:  
 Refer to Plan Layout Sheet 3 and Roadway Plans for median layout and dimensions.

**TOP SLAB  
 HARRISON AVENUE  
 OVER THE SOUTHEAST DRAINAGE WAY  
 CITY OF ROCKFORD  
 WINNEBAGO COUNTY  
 STATION 143+74.0  
 STRUCTURE No. 101-6105**

Sheet 6 of 19

| REVISIONS |             |      |
|-----------|-------------|------|
| REV. NO.  | DESCRIPTION | DATE |
|           |             |      |
|           |             |      |
|           |             |      |

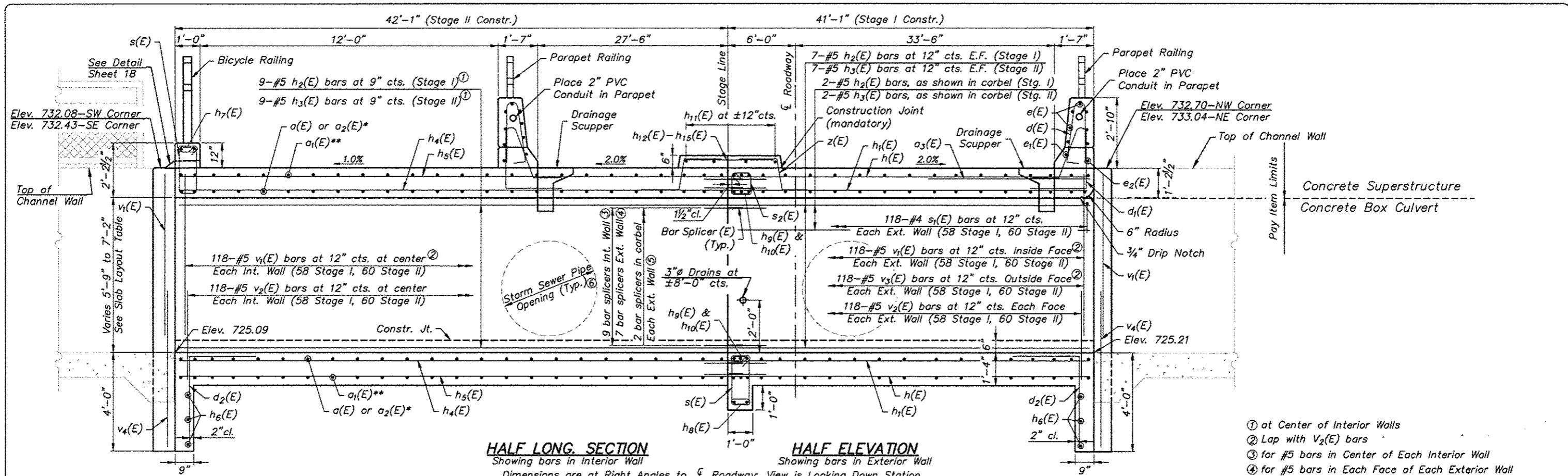

- ① at Center of Interior Walls
- ② Lap with  $V_2(E)$  bars
- ③ for #5 bars in Center of Each Interior Wall
- ④ for #5 bars in Each Face of Each Exterior Wall
- ⑤ for #5 bars in Corbel of Each Exterior Wall
- ⑥ Showing Openings in Exterior West Wall; see Sheet B for additional Storm Sewer Pipe Opening Information and Reinforcement Details

\* Alternate Lap over East and West Inside Walls.  
 \*\* Lap in Center of Center Barrel.  
 \*\*\* Minimum dimension at lowest end of culvert and formed level across entire width of roadway.

**MINIMUM BAR LAP**

- #4 bar - 2'-1"
- #5 bar - 2'-7"
- #6 bar - 3'-1"
- #7 bar - 4'-2"
- #8 bar - 5'-5"
- #9 bar - 6'-10"

**SECTION THROUGH BARREL  
 HARRISON AVENUE  
 OVER THE SOUTHEAST DRAINAGE WAY  
 CITY OF ROCKFORD  
 WINNEBAGO COUNTY  
 STATION 143+74.0  
 STRUCTURE No. 101-6105**

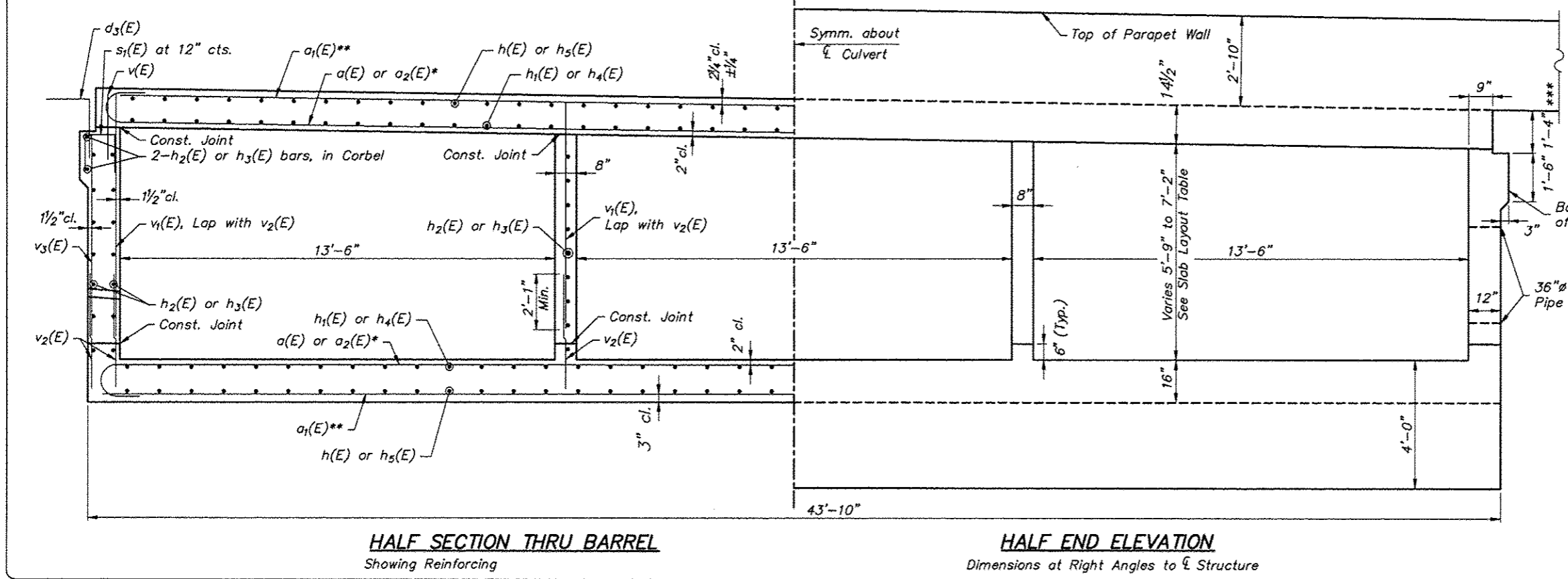

**HALF SECTION THRU BARREL**  
 Showing Reinforcing

**HALF END ELEVATION**  
 Dimensions at Right Angles to  $\perp$  Structure

**FEHR GRAHAM**  
 ENGINEERING & ENVIRONMENTAL  
 ILLINOIS DESIGN FIRM NO. 184-003525  
 © 2013 FEHR-GRAHAM

ILLINOIS  
 IOWA  
 WISCONSIN

**McClure**  
 Engineering Associates, Inc.  
 7282 Argue Drive, Rockford, Illinois 61107-5037  
 (815) 398-2332, FAX (815) 398-2496  
 Design Firm License: Illinois 194-00016  
 Copyright 2013 By McClure Engineering Associates, Inc.

PROJECT AND LOCATION:  
 HARRISON AVENUE  
 RECONSTRUCTION 2012  
 PHASE 1  
 ROCKFORD, ILLINOIS

DRAWN BY: J/WH  
 APPROVED BY: CTB  
 DATE: 6/12/15  
 SCALE: 1"=2'

| REVISIONS |             |      |
|-----------|-------------|------|
| REV. NO.  | DESCRIPTION | DATE |
|           |             |      |
|           |             |      |
|           |             |      |

DRAWING:  
 SECTION THROUGH BARREL  
 STRUCTURE NO. 101-6105

JOB NUMBER:  
 11-128  
 SHEET NUMBER:  
 380 of 588



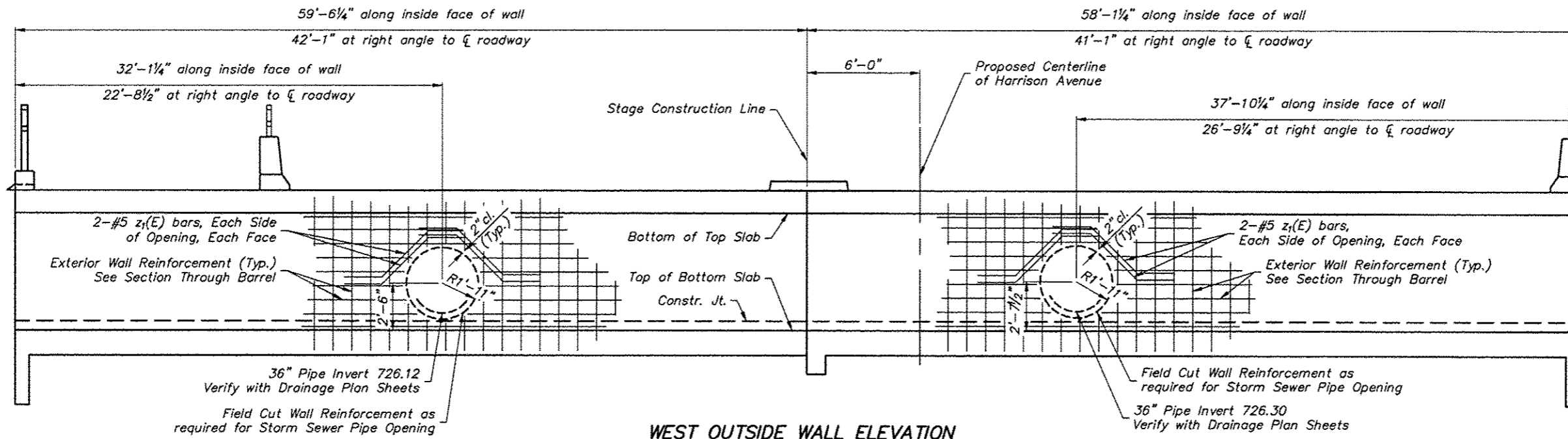

**WEST OUTSIDE WALL ELEVATION  
(Looking West)**

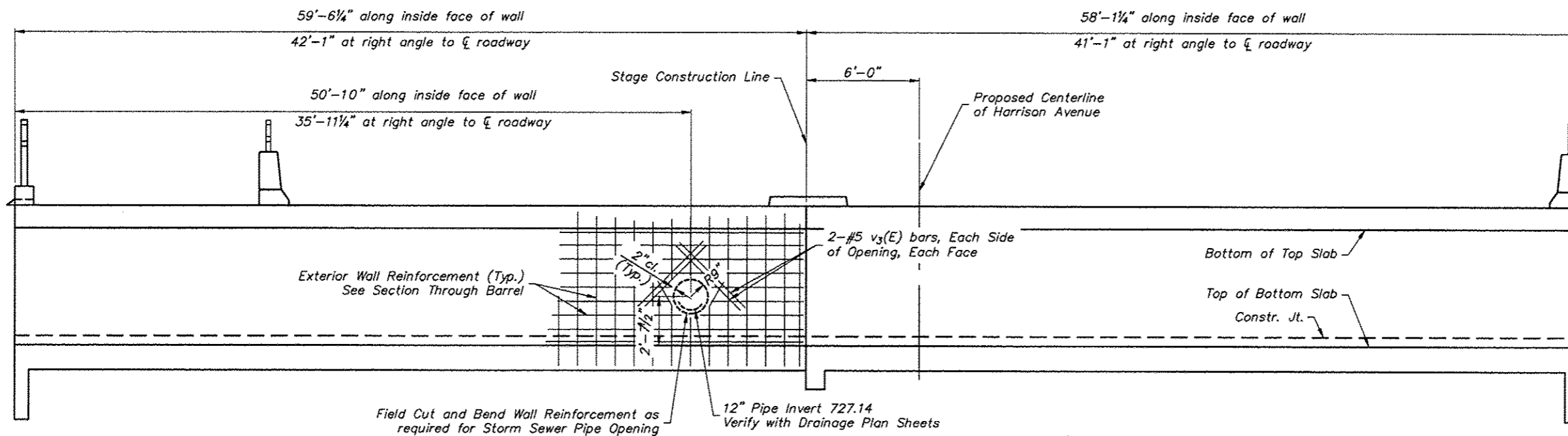

**EAST OUTSIDE WALL ELEVATION  
(Looking West)**

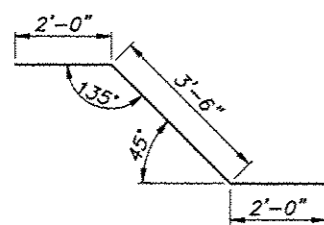

**BAR z1(E)**

**NOTES:**  
See Sheet 3 for Plan View

Verify pipe location dimensions and invert elevations with Drainage Plan Sheets and field information.

Cut pipe flush with inside face of exterior box culvert wall. Install 1/2" preformed joint filler around the perimeter of pipe.

Refer to specifications for seepage collar details. Eliminate wall drain at storm sewer pipe openings. Cost of Seepage Collar shall be included with Concrete Box Culverts.

**CULVERT WALL OPENINGS  
HARRISON AVENUE  
OVER THE SOUTHEAST DRAINAGE WAY  
CITY OF ROCKFORD  
WINNEBAGO COUNTY  
STATION 143+74.0  
STRUCTURE No. 101-6105**

Sheet 8 of 19

**FEHR GRAHAM**

ENGINEERING & ENVIRONMENTAL  
ILLINOIS DESIGN FIRM NO. 184-003525

© 2013 FEHR-GRAHAM

ILLINOIS  
IOWA  
WISCONSIN

**McClure**  
Engineering Associates, Inc.  
7282 Argus Drive Rookford, Illinois 61107-6837  
(815) 398-2332 FAX (815) 398-2498  
Design Firm License: Illinois 164-000816  
Copyright 2013 By McClure Engineering Associates, Inc.

PROJECT AND LOCATION:  
HARRISON AVENUE  
RECONSTRUCTION 2012  
PHASE 1  
ROCKFORD, ILLINOIS

DRAWN BY: JWH  
APPROVED BY: CTB  
DATE: 6/12/15  
SCALE: NA

| REVISIONS |             |      |
|-----------|-------------|------|
| REV. NO.  | DESCRIPTION | DATE |
|           |             |      |
|           |             |      |
|           |             |      |

DRAWING:  
CULVERT WALL OPENINGS  
STRUCTURE NO. 101-6105

JOB NUMBER:  
11-128

SHEET NUMBER:  
381 of 588

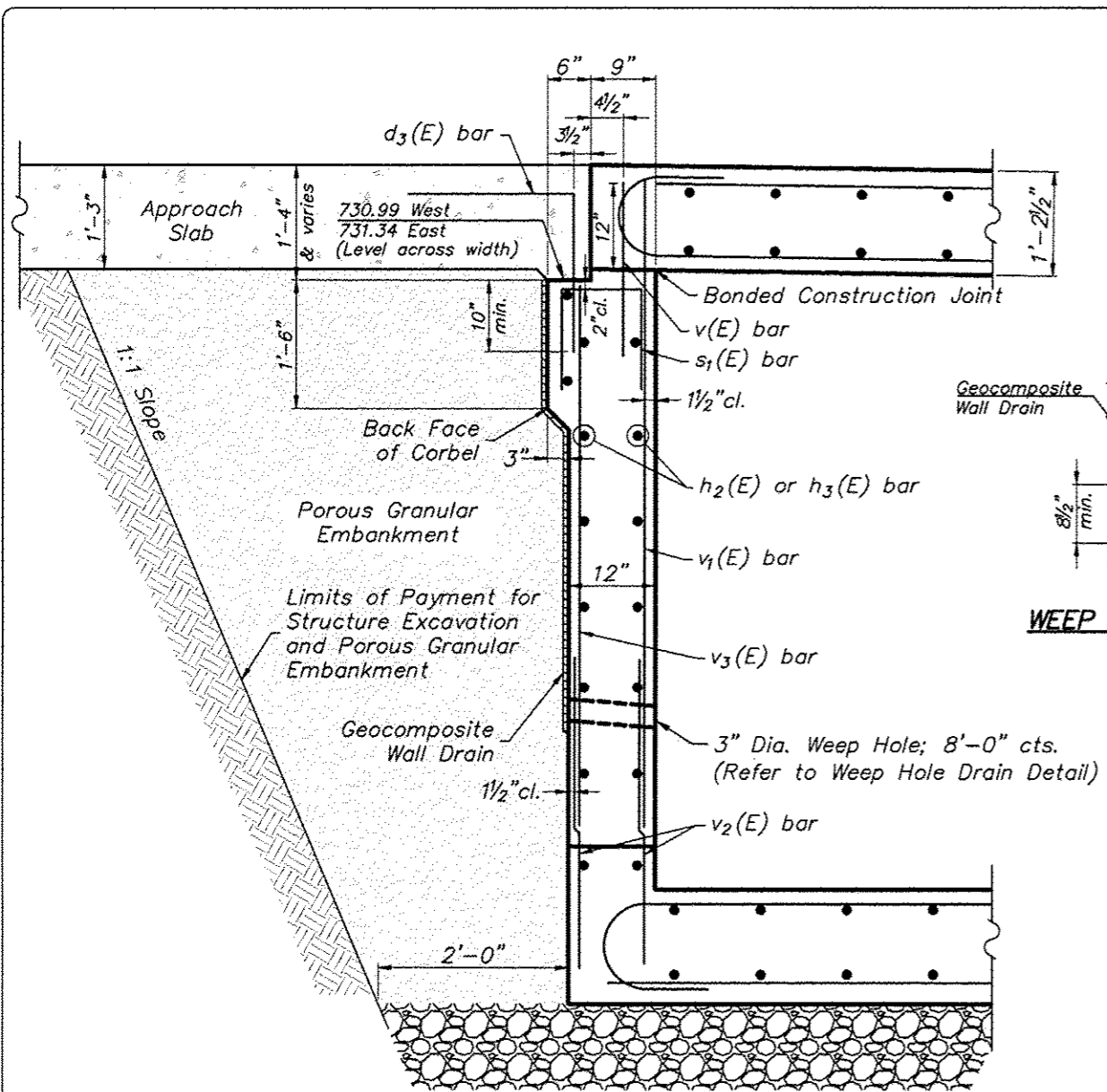

**SECTION THRU OUTSIDE CULVERT WALL**

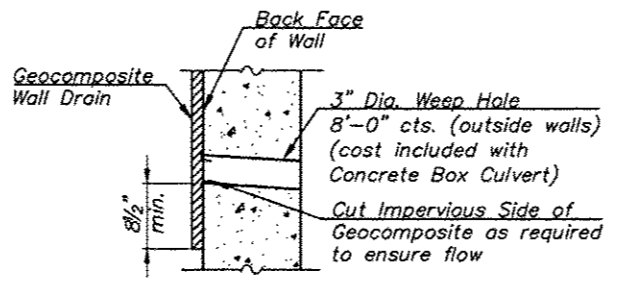

**WEEP HOLE DRAIN DETAIL**

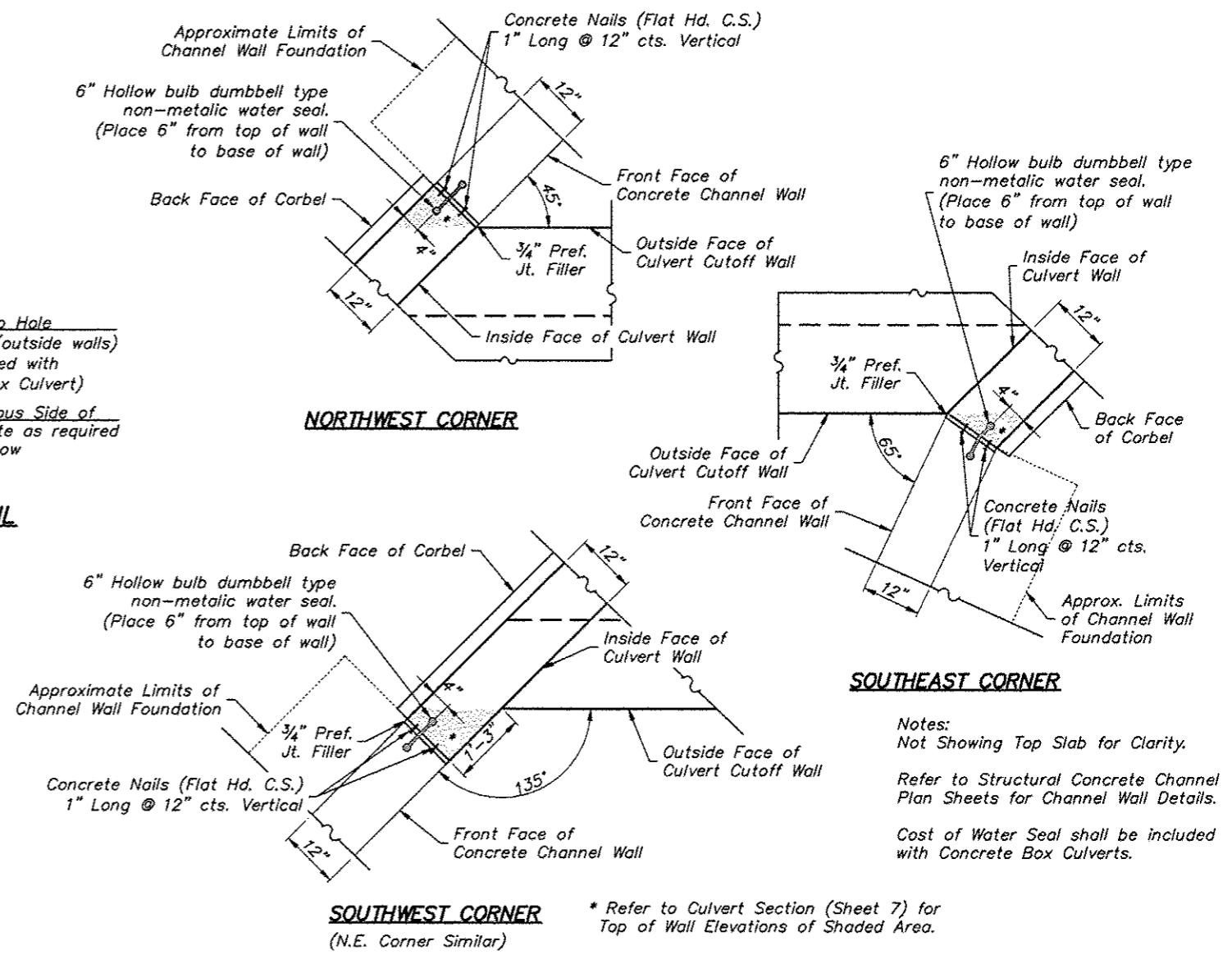

**NORTHWEST CORNER**

**SOUTHWEST CORNER**

Notes:  
 Not Showing Top Slab for Clarity.  
 Refer to Structural Concrete Channel Wall Plan Sheets for Channel Wall Details.  
 Cost of Water Seal shall be included with Concrete Box Culverts.

\* Refer to Culvert Section (Sheet 7) for Top of Wall Elevations of Shaded Area.

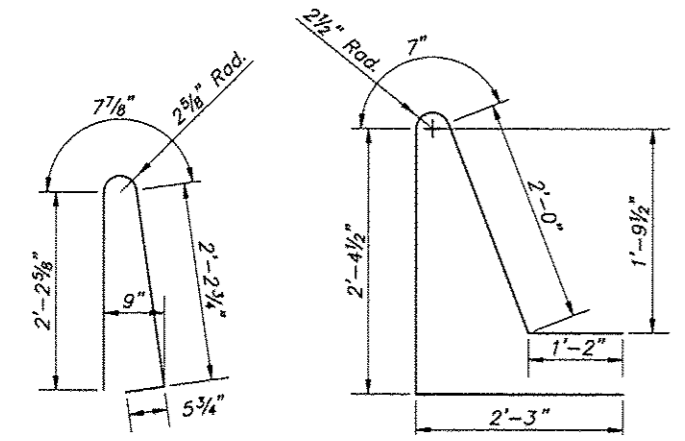

**BAR d(E)**

**BAR d1(E)**

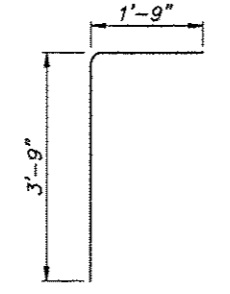

**BAR d2(E)**

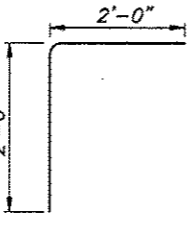

**BAR d3(E)**

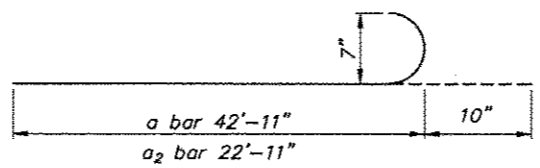

**BAR a(E) and a2(E)**

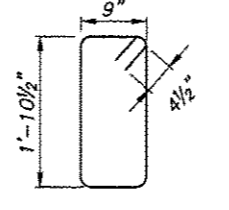

**BAR s(E)**

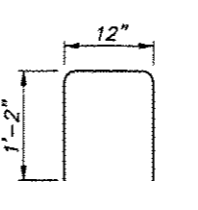

**BAR s1(E)**

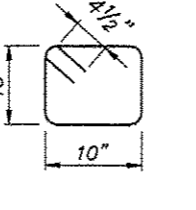

**BAR s2(E)**

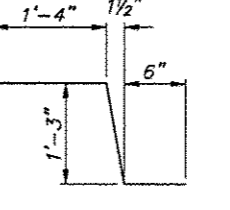

**BAR z(E)**

**END DETAILS AT CONCRETE CHANNEL WALL LIMITS**  
 (Plan Views: No Scale)

**CULVERT DETAILS**  
**HARRISON AVENUE**  
**OVER THE SOUTHEAST DRAINAGE WAY**  
**CITY OF ROCKFORD**  
**WINNEBAGO COUNTY**  
**STATION 143+74.0**  
**STRUCTURE No. 101-6105**

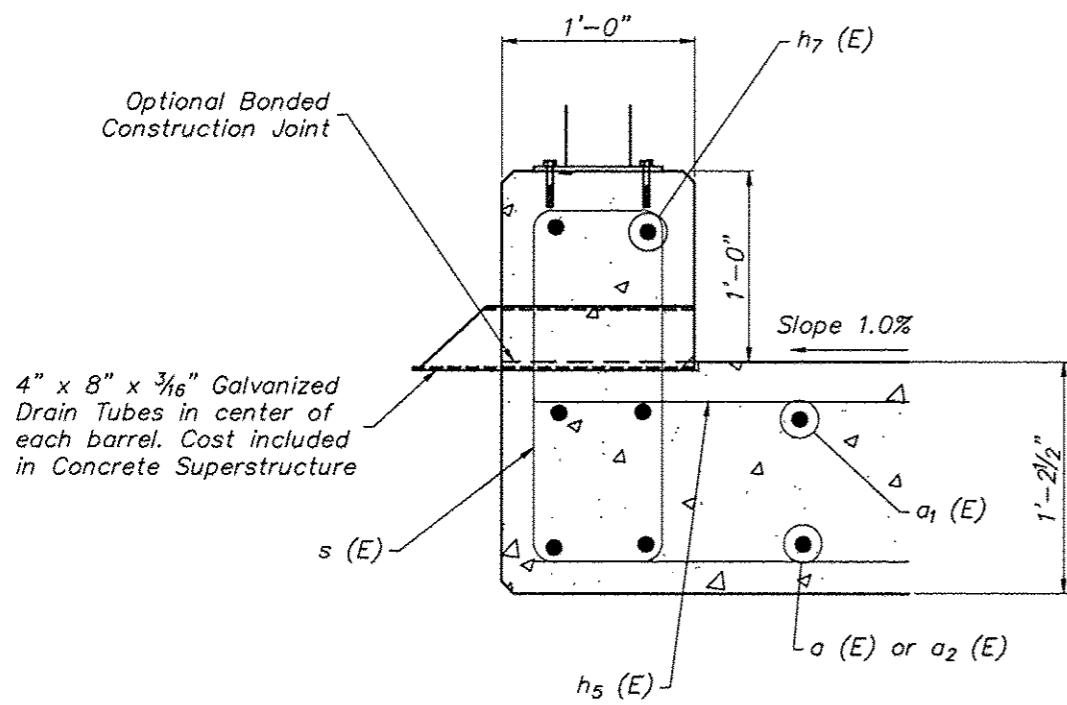

**SIDEWALK DRAIN DETAILS**

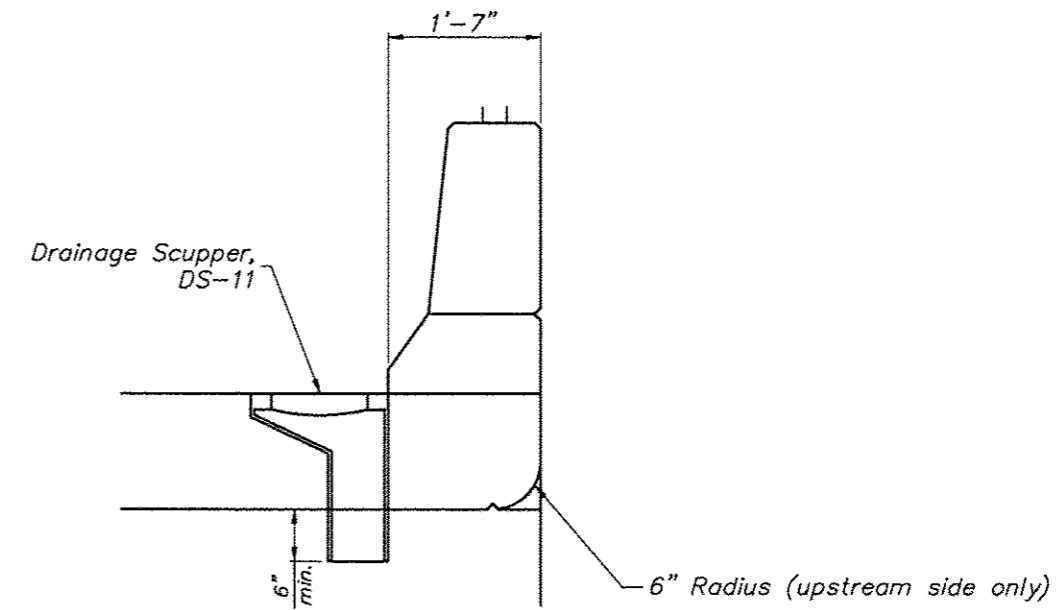

**SECTION A-A**

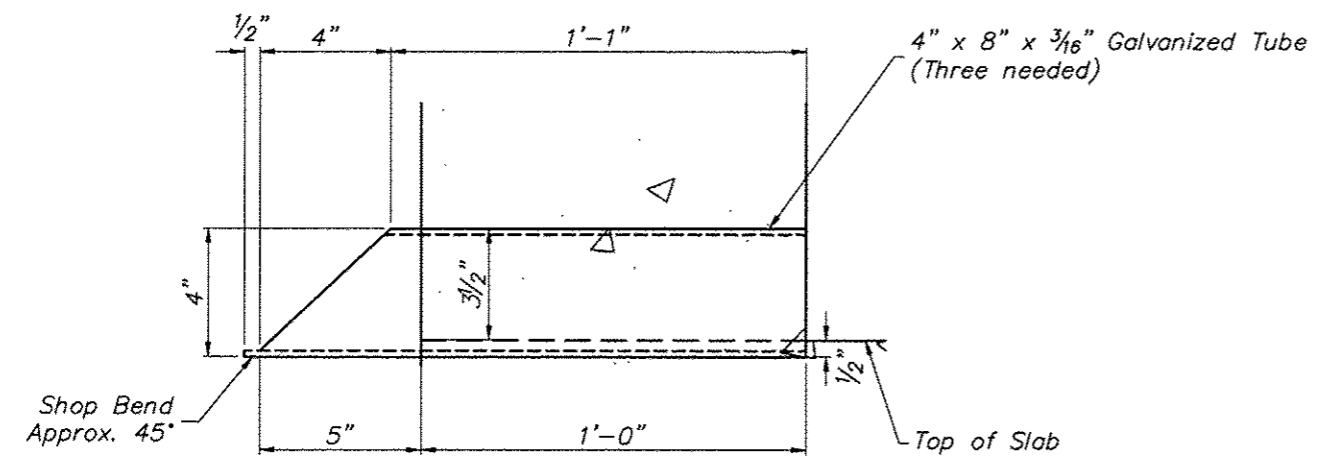

**SIDEWALK DRAIN DETAILS**

2-#5 a4 (E) bars at 4" cts. (1'-6" long) tied to bottom of Top Reinforcement Mat. (Typical)

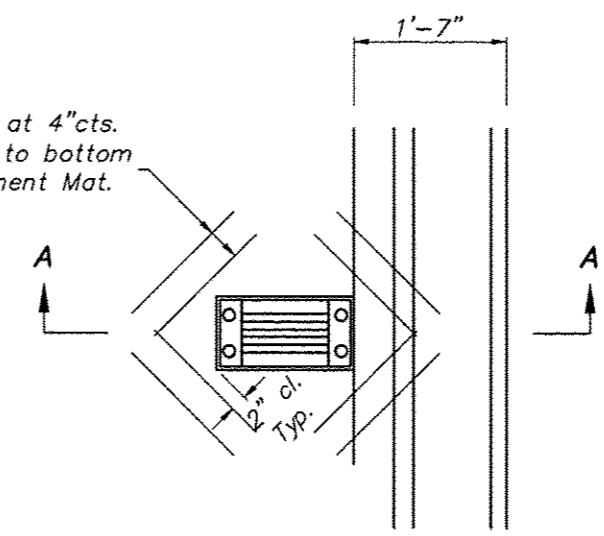

**DRAINAGE SCUPPER DS-11 DETAIL**

Note:  
Reinforcement bars designated (E) shall be epoxy coated.  
Cut longitudinal reinforcement to clear drainage scuppers.

**DECK DRAIN DETAILS**  
**HARRISON AVENUE**  
**OVER THE SOUTHEAST DRAINAGE WAY**  
**CITY OF ROCKFORD**  
**WINNEBAGO COUNTY**  
**STATION 143+74.0**  
**STRUCTURE No. 101-6105**

| REVISIONS |             |      |
|-----------|-------------|------|
| REV. NO.  | DESCRIPTION | DATE |
|           |             |      |
|           |             |      |
|           |             |      |

**NORTH EDGE OF APPROACH SLAB**

| Location                | Station   | Offset   | Theoretical Grade Elevations |
|-------------------------|-----------|----------|------------------------------|
| W. End E. Approach Slab | 144+39.72 | 35.08' L | 733.05                       |
| A                       | 144+49.72 | 35.08' L | 733.10                       |
| B                       | 144+58.64 | 34.00' L | 733.16                       |
| E. End E. Approach Slab | 144+68.64 | 34.00' L | 733.20                       |

**NORTH PGL**

| Location                | Station   | Offset  | Theoretical Grade Elevations |
|-------------------------|-----------|---------|------------------------------|
| W. End E. Approach Slab | 144+12.64 | 8.00' L | 733.44                       |
| A                       | 144+22.64 | 8.00' L | 733.50                       |
| B                       | 144+32.64 | 8.00' L | 733.55                       |
| E. End E. Approach Slab | 144+42.64 | 8.00' L | 733.61                       |

**STAGE CONSTRUCTION LINE**

| Location                | Station   | Offset  | Theoretical Grade Elevations |
|-------------------------|-----------|---------|------------------------------|
| W. End E. Approach Slab | 143+98.64 | 6.00' R | 733.39                       |
| A                       | 144+08.64 | 6.00' R | 733.45                       |
| B                       | 144+18.64 | 6.00' R | 733.51                       |
| E. End E. Approach Slab | 144+28.64 | 6.00' R | 733.57                       |

**SOUTH PGL**

| Location                | Station   | Offset  | Theoretical Grade Elevations |
|-------------------------|-----------|---------|------------------------------|
| W. End E. Approach Slab | 143+96.64 | 8.00' R | 733.34                       |
| A                       | 144+06.64 | 8.00' R | 733.40                       |
| B                       | 144+16.64 | 8.00' R | 733.46                       |
| E. End E. Approach Slab | 144+26.64 | 8.00' R | 733.52                       |

**SOUTH EDGE OF APPROACH SLAB**

| Location                | Station   | Offset   | Theoretical Grade Elevations |
|-------------------------|-----------|----------|------------------------------|
| W. End E. Approach Slab | 143+69.56 | 35.08' R | 732.64                       |
| A                       | 143+79.56 | 35.08' R | 732.70                       |
| B                       | 143+90.64 | 34.00' R | 732.78                       |
| E. End E. Approach Slab | 144+00.64 | 34.00' R | 732.84                       |

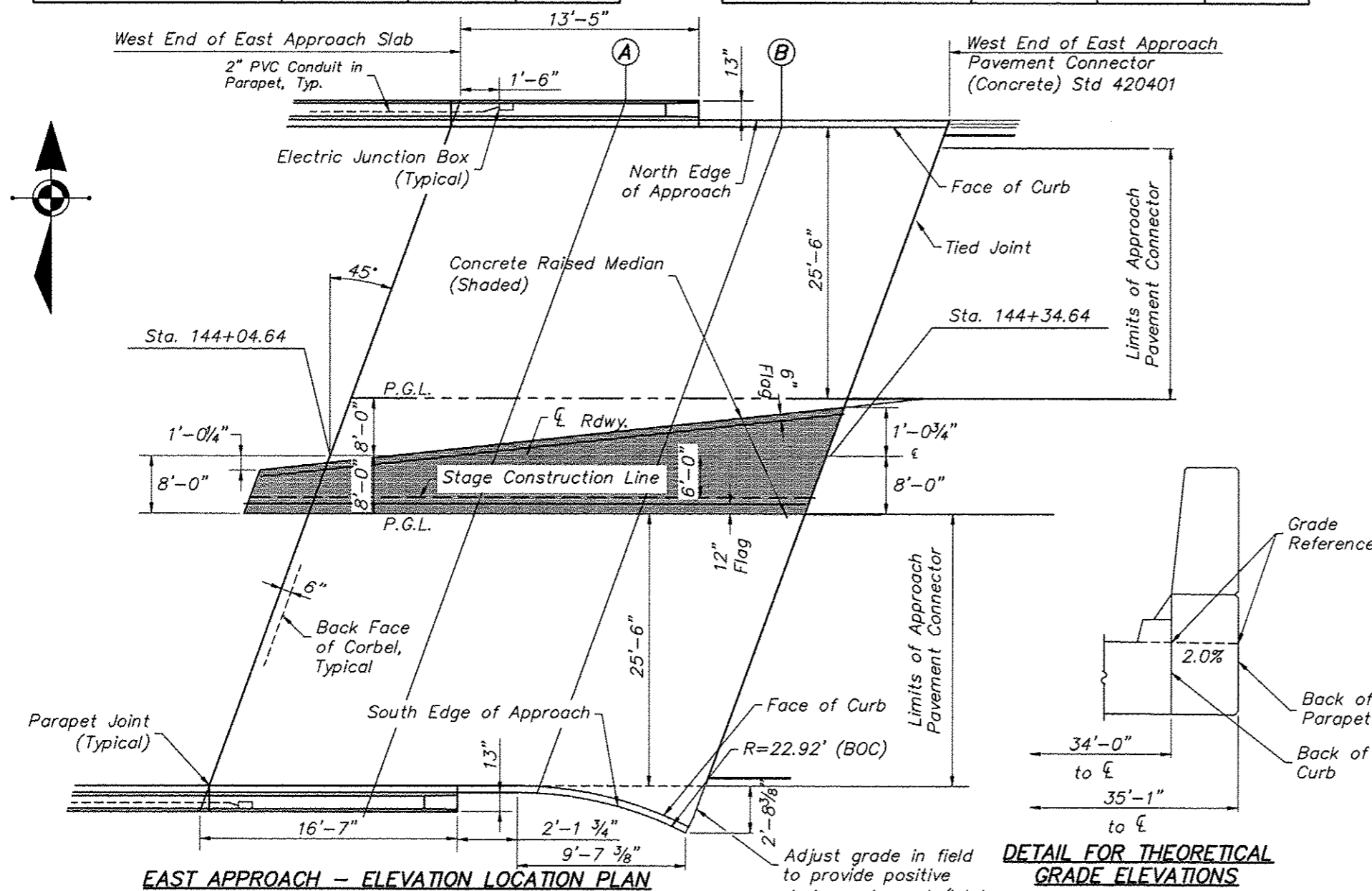

**EAST APPROACH SLAB ELEVATIONS  
HARRISON AVENUE  
OVER THE SOUTHEAST DRAINAGE WAY  
CITY OF ROCKFORD  
WINNEBAGO COUNTY  
STATION 143+74.0  
STRUCTURE No. 101-6105**

Sheet 11 of 19

Note:  
Refer to Plan Layout Sheet 3  
and Roadway Plans for median  
layout and dimensions.

**FEHR GRAHAM**

ENGINEERING & ENVIRONMENTAL

ILLINOIS DESIGN FIRM NO. 184-003525  
© 2013 FEHR-GRAHAM

ILLINOIS  
IOWA  
WISCONSIN

**McClure**  
Engineering Associates, Inc.  
7282 Argus Drive  
Rockford, Illinois 61107-6837  
(815) 398-2332 FAX (815) 398-2486  
Design Firm License: Illinois 184-000316  
Copyright 2013 By McClure Engineering Associates, Inc.

PROJECT AND LOCATION:  
HARRISON AVENUE  
RECONSTRUCTION 2012  
PHASE 1  
ROCKFORD, ILLINOIS

DRAWN BY: MS  
APPROVED BY: CTB  
DATE: 6/12/15  
SCALE: NA  
NA

| REVISIONS |             |      |
|-----------|-------------|------|
| REV. NO.  | DESCRIPTION | DATE |
|           |             |      |
|           |             |      |
|           |             |      |

DRAWING:  
EAST APPROACH SLAB ELEVATIONS  
STRUCTURE NO. 101-6105

JOB NUMBER:  
11-128

SHEET NUMBER:  
384 of 588

**NORTH EDGE OF APPROACH SLAB**

| Location                | Station   | Offset   | Theoretical Grade Elevations |
|-------------------------|-----------|----------|------------------------------|
| W. End W. Approach Slab | 143+47.36 | 34.00' L | 732.52                       |
| A                       | 143+57.36 | 34.00' L | 732.58                       |
| B                       | 143+68.44 | 35.08' L | 732.63                       |
| E. End W. Approach Slab | 143+78.44 | 35.08' L | 732.69                       |

**NORTH PGL**

| Location                | Station   | Offset  | Theoretical Grade Elevations |
|-------------------------|-----------|---------|------------------------------|
| W. End W. Approach Slab | 143+21.36 | 8.00' L | 732.89                       |
| A                       | 143+31.36 | 8.00' L | 732.95                       |
| B                       | 143+44.36 | 8.00' L | 733.01                       |
| E. End W. Approach Slab | 143+51.36 | 8.00' L | 733.07                       |

**STAGE CONSTRUCTION LINE**

| Location                | Station   | Offset  | Theoretical Grade Elevations |
|-------------------------|-----------|---------|------------------------------|
| W. End W. Approach Slab | 143+07.36 | 6.00' R | 732.84                       |
| A                       | 143+17.36 | 6.00' R | 732.90                       |
| B                       | 143+27.36 | 6.00' R | 732.96                       |
| E. End W. Approach Slab | 143+37.36 | 6.00' R | 733.02                       |

**SOUTH PGL**

| Location                | Station   | Offset  | Theoretical Grade Elevations |
|-------------------------|-----------|---------|------------------------------|
| W. End W. Approach Slab | 143+05.36 | 8.00' R | 732.79                       |
| A                       | 143+15.36 | 8.00' R | 732.85                       |
| B                       | 143+25.36 | 8.00' R | 732.91                       |
| E. End W. Approach Slab | 143+35.36 | 8.00' R | 732.97                       |

**SOUTH EDGE OF APPROACH SLAB**

| Location                | Station   | Offset   | Theoretical Grade Elevations |
|-------------------------|-----------|----------|------------------------------|
| W. End W. Approach Slab | 142+79.36 | 34.00' R | 732.11                       |
| A                       | 142+89.36 | 34.00' R | 732.17                       |
| B                       | 142+98.27 | 35.08' R | 732.20                       |
| E. End W. Approach Slab | 143+08.27 | 35.08' R | 732.27                       |

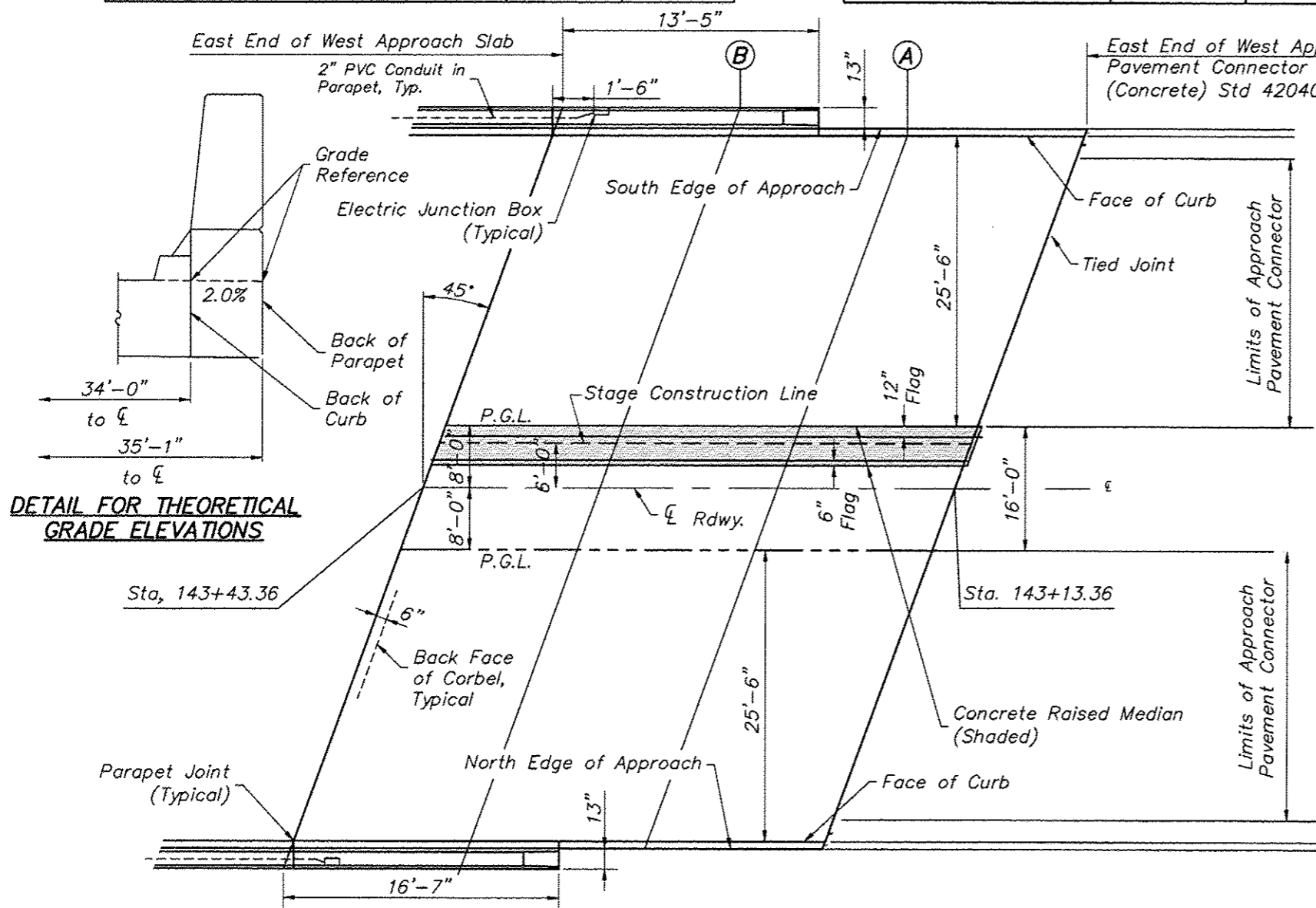

**WEST APPROACH - ELEVATION LOCATION PLAN**

Note: Refer to Plan Layout Sheet 3 and Roadway Plans for median layout and dimensions.

**WEST APPROACH SLAB ELEVATIONS  
HARRISON AVENUE  
OVER THE SOUTHEAST DRAINAGE WAY  
CITY OF ROCKFORD  
WINNEBAGO COUNTY  
STATION 143+74.0  
STRUCTURE No. 101-6105**

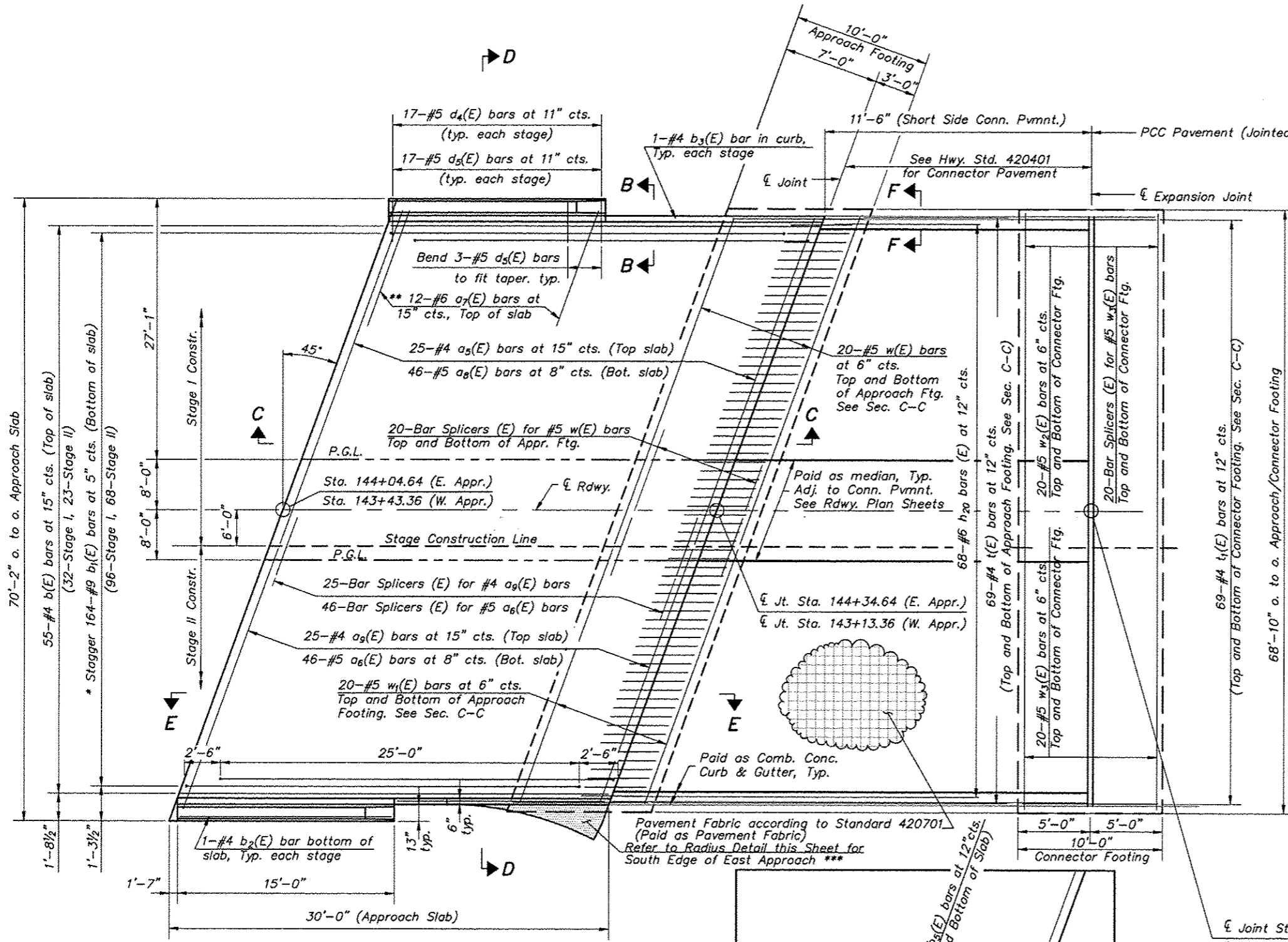

**Notes:**  
 See sheet 14 of 19 for Sections C-C & D-D and View E-E.  
 $a_5(E)$ ,  $a_6(E)$ ,  $a_8(E)$  and  $a_9(E)$  bar spacings measured along  $\xi$  Rdwy.  
 Refer to Section D-D for placement of  $z_2$  (E) bars and  $h_{19}$  (E) bars in Median. Tilt  $z_2$  (E) bars as necessary in west approach for clearance.  
 Refer to View E-E for parapet reinforcement and Parapet Details and Rail Post Spacing sheet for railing details and parapet joint details.  
 Median and Comb. Conc. Curb & Gutter attached to the PCC Connector Pavement will be paid at the contract unit price for the item constructed. Tie bars as shown on the Standards shall be included in said payment.

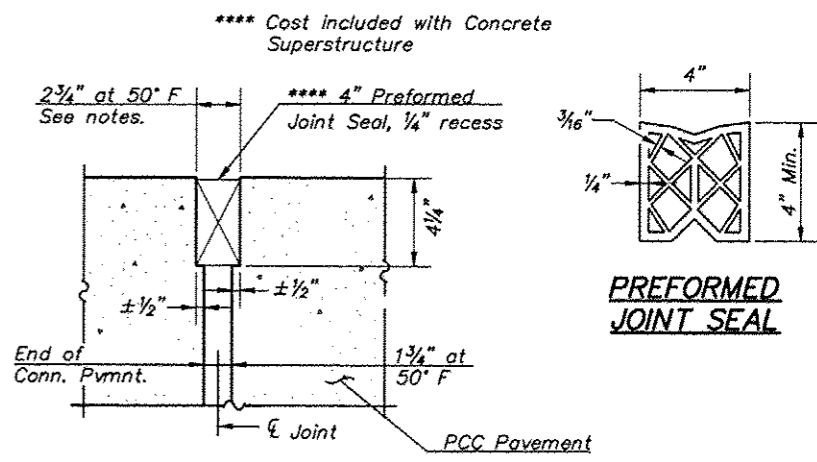

**RIGID PAVEMENT DETAIL A**

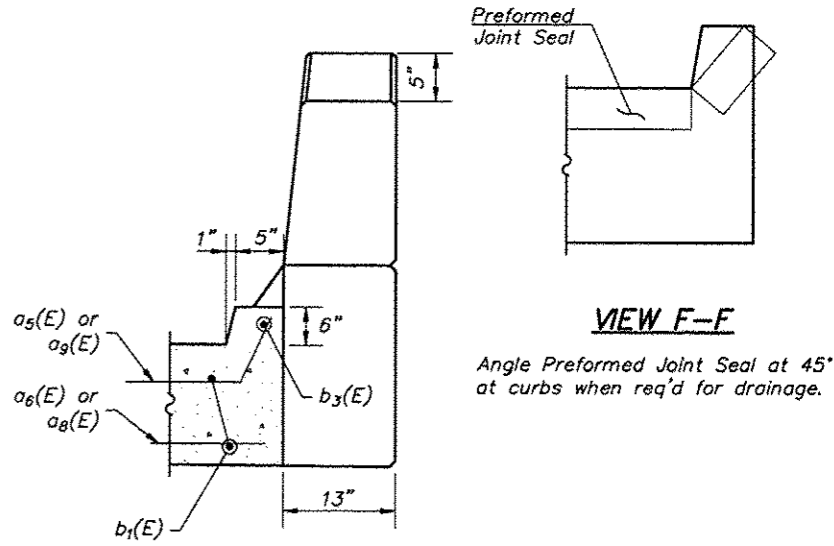

**VIEW F-F**  
 Angle Preformed Joint Seal at 45° at curbs when req'd for drainage.

**CULVERT APPROACH SLAB  
 HARRISON AVENUE  
 OVER THE SOUTHEAST DRAINAGE WAY  
 CITY OF ROCKFORD  
 WINNEBAGO COUNTY  
 STATION 143+74.0  
 STRUCTURE No. 101-6105**

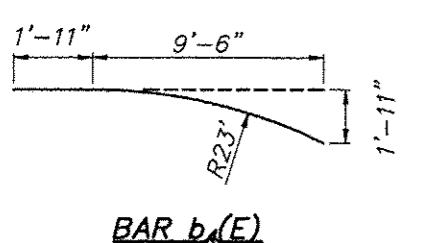

**BAR  $b_1(E)$**

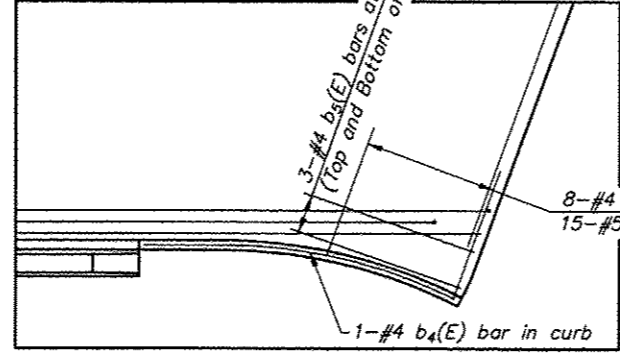

**RADIUS DETAIL**  
 (See Roadway Plans for Layout Dimensions)

\* Tilt #9  $b_1(E)$  bars as required to maintain clearance.  
 \*\* Space between  $a_5(E)$  or  $a_6(E)$  bars, typ. each parapet.  
 \*\*\* Turn hook on  $a_9$  bar in radius.

Note:  
 Refer to Plan Layout Sheet 3 and Roadway Plans for median layout and dimensions.

**FEHR GRAHAM**  
 ENGINEERING & ENVIRONMENTAL  
 ILLINOIS DESIGN FIRM NO. 184-003523  
 © 2013 FEHR-GRAHAM

ILLINOIS  
 IDWA  
 WISCONSIN

**McClure**  
 Engineering Associates, Inc.  
 7282 Argus Drive  
 Rockford, Illinois 61107-5937  
 (616) 398-2332 FAX (616) 398-2486  
 Design Firm License: Illinois 184-000818  
 Copyright 2013 By McClure Engineering Associates, Inc.

PROJECT AND LOCATION:  
 HARRISON AVENUE  
 RECONSTRUCTION 2012  
 PHASE 1  
 ROCKFORD, ILLINOIS

DRAWN BY: MS  
 APPROVED BY: CTB  
 DATE: 6/12/15  
 SCALE: NTS

| REVISIONS |             |      |
|-----------|-------------|------|
| REV. NO.  | DESCRIPTION | DATE |
|           |             |      |
|           |             |      |
|           |             |      |

DRAWING:  
 CULVERT APPROACH SLAB  
 STRUCTURE NO. 101-6105

JOB NUMBER:  
 11-128  
 SHEET NUMBER:  
 386 of 588

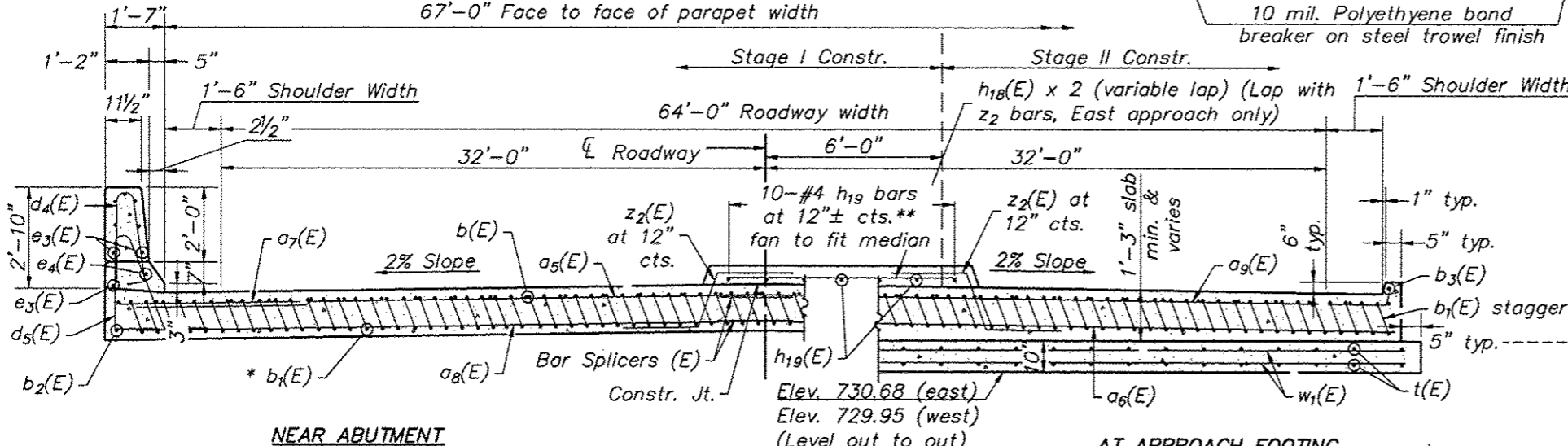
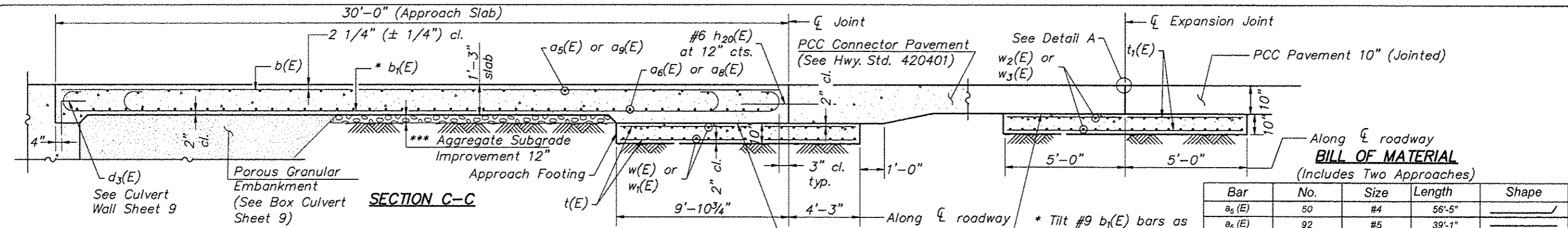

\* Tilt #9 b<sub>1</sub>(E) bars as required to maintain clearance.  
 \*\* 2 h<sub>19</sub>(E) bars in top of west approach; 8 h<sub>19</sub>(E) bars in top of east approach; cut to fit.  
 \*\*\* Paid as Aggregate Subgrade Improvement 12"

Along  $\bar{C}$  roadway  
**BILL OF MATERIAL**  
 (Includes Two Approaches)

| Bar                       | No. | Size    | Length | Shape |
|---------------------------|-----|---------|--------|-------|
| a <sub>5</sub> (E)        | 50  | #4      | 56'-5" | —     |
| a <sub>6</sub> (E)        | 92  | #5      | 39'-1" | —     |
| a <sub>7</sub> (E)        | 48  | #6      | 6'-6"  | —     |
| a <sub>8</sub> (E)        | 92  | #5      | 56'-1" | —     |
| a <sub>9</sub> (E)        | 50  | #4      | 39'-5" | —     |
| a <sub>10</sub> (E)       | 8   | #4      | 4'-2"  | —     |
| a <sub>11</sub> (E)       | 15  | #5      | 4'-2"  | —     |
| b(E)                      | 110 | #4      | 29'-8" | —     |
| b <sub>1</sub> (E)        | 328 | #9      | 29'-9" | —     |
| b <sub>2</sub> (E)        | 4   | #4      | 14'-8" | —     |
| b <sub>3</sub> (E)        | 3   | #4      | 14'-8" | —     |
| b <sub>4</sub> (E)        | 1   | #4      | 11'-8" | —     |
| b <sub>5</sub> (E)        | 6   | #4      | 10'-0" | —     |
| d <sub>4</sub> (E)        | 68  | #5      | 5'-7"  | —     |
| d <sub>5</sub> (E)        | 68  | #5      | 7'-11" | —     |
| e <sub>3</sub> (E)        | 32  | #4      | 14'-8" | —     |
| e <sub>4</sub> (E)        | 4   | #8      | 14'-8" | —     |
| h <sub>18</sub> (E)       | 60  | #5      | 8'-0"  | —     |
| h <sub>19</sub> (E)       | 10  | #4      | 33'-4" | —     |
| h <sub>20</sub> (E)       | 136 | #6      | 2'-6"  | —     |
| t(E)                      | 138 | #4      | 13'-8" | —     |
| t <sub>1</sub> (E)        | 138 | #4      | 9'-8"  | —     |
| w(E)                      | 80  | #5      | 56'-9" | —     |
| w <sub>1</sub> (E)        | 80  | #5      | 39'-9" | —     |
| w <sub>2</sub> (E)        | 80  | #5      | 40'-1" | —     |
| w <sub>3</sub> (E)        | 80  | #5      | 28'-1" | —     |
| z <sub>2</sub> (E)        | 120 | #5      | 4'-5"  | —     |
| Concrete Superstructure   |     | Cu. Yd. | 227.7  |       |
| Concrete Box Culvert      |     | Cu. Yd. | 102.6  |       |
| Reinforcement Bars, Epoxy |     | Pound   | 67,467 |       |
| Bar Splicers              |     | Each    | 302    |       |
| PCC Connector Pavement    |     | Sq. Yd. | 464    |       |
| Pavement Fabric           |     | Sq. Yd. | 464    |       |

**SECTION D-D**  
 (See plan for dimensions not shown)

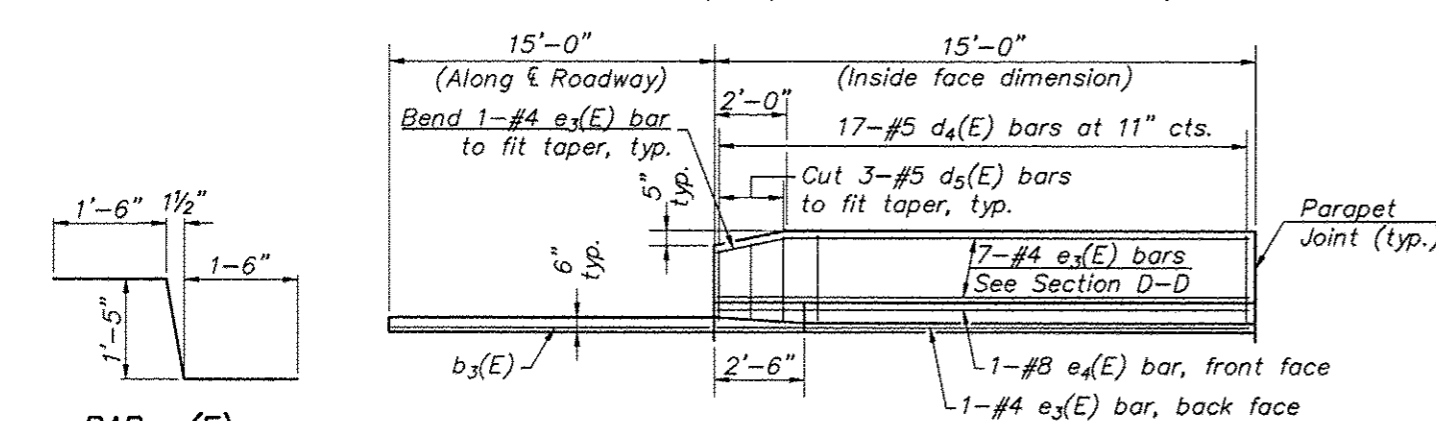

BAR z<sub>2</sub>(E)

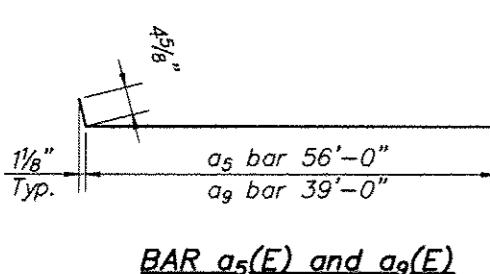

BAR a<sub>5</sub>(E) and a<sub>9</sub>(E)

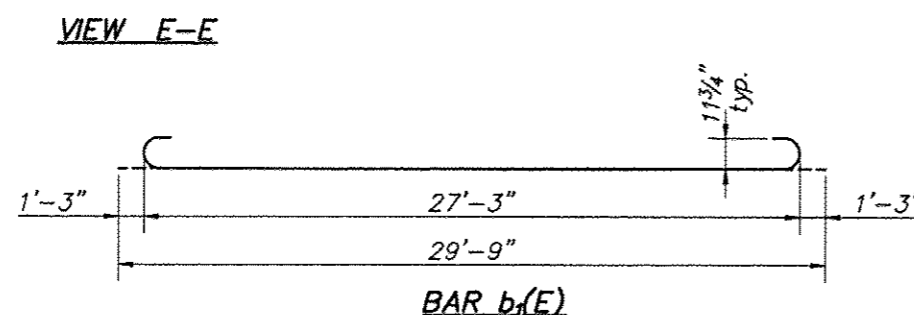

BAR b<sub>1</sub>(E)

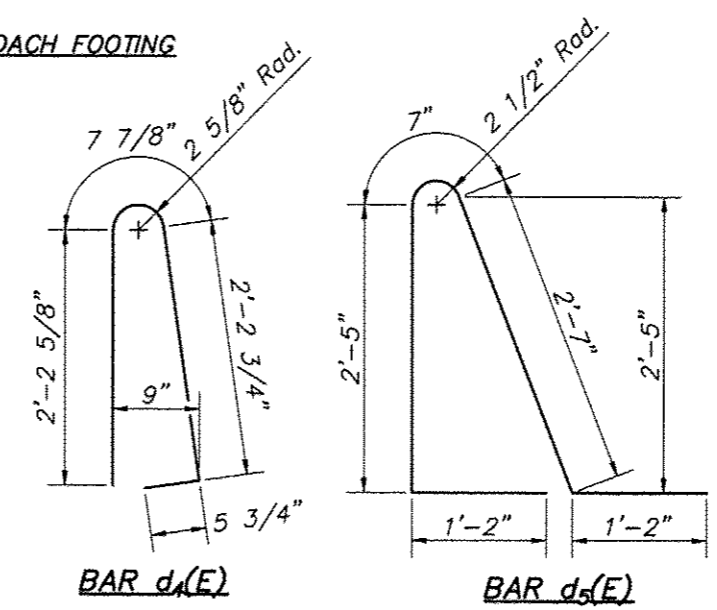

BAR d<sub>4</sub>(E)

BAR d<sub>5</sub>(E)

- NOTES:**
- See sheet 13 of 19 for Detail A and View B-B.
  - Approach slab and parapets shall be paid for as Concrete Superstructure.
  - Approach footing concrete shall be paid for as Concrete Box Culvert.
  - Reinforcement shall be paid for as Reinforcement Bars, Epoxy Coated.
  - The approach footing maximum applied service bearing pressure (Q<sub>max</sub>) = 2.0 ksf.
  - For bar splicer details, see sheet 18 of 19.
  - Cost of excavation for approach footing is included with Connector Pavement PCC.
  - For Porous Granular Embankment and drainage treatment details, see sheet 9 of 19.
  - For Additional parapet details, see sheet 15 of 19.

**CULVERT APPROACH SLAB DETAILS**  
**HARRISON AVENUE**  
**OVER THE SOUTHEAST DRAINAGE WAY**  
**CITY OF ROCKFORD**  
**WINNEBAGO COUNTY**  
**STATION 143+74.0**  
**STRUCTURE No. 101-6105**  
**Sheet 14 of 19**

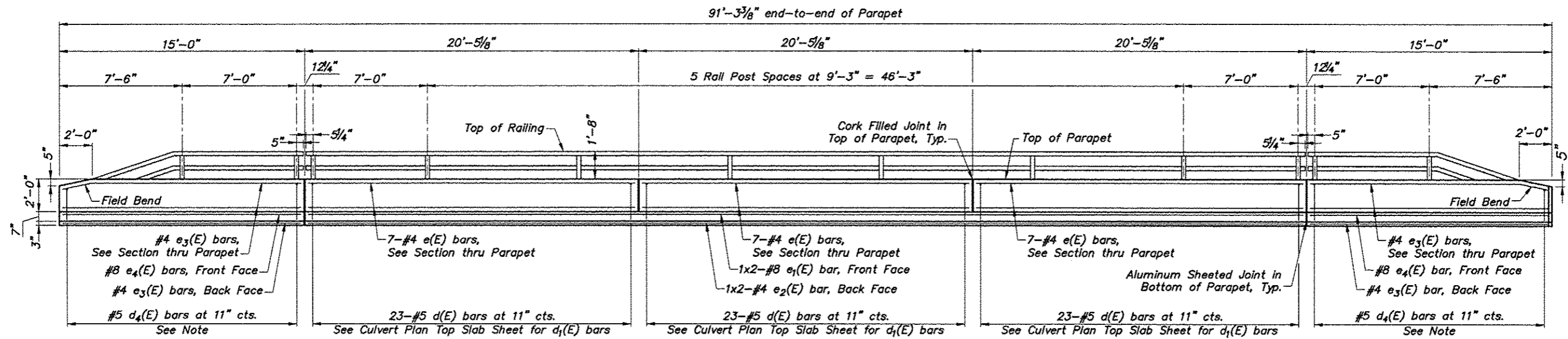

Note:  
See View E-E on Culvert Approach Slab Detail sheet for reinforcement details in approach slab parapet.

**PARAPET ELEVATION**  
(Looking North at North Parapet)  
(South Parapet Similar)

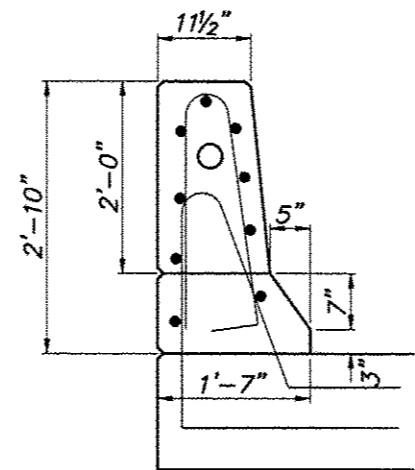

**PARAPET DIMENSIONS**

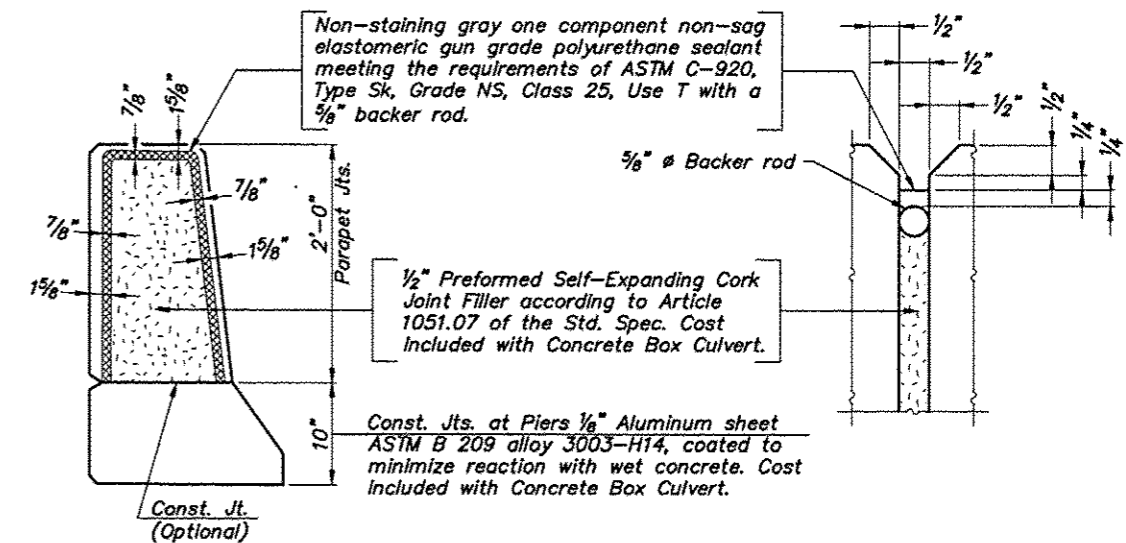

**PARAPET JOINT DETAILS**  
(Cork Filled Joint in Curb Parapet Similar)

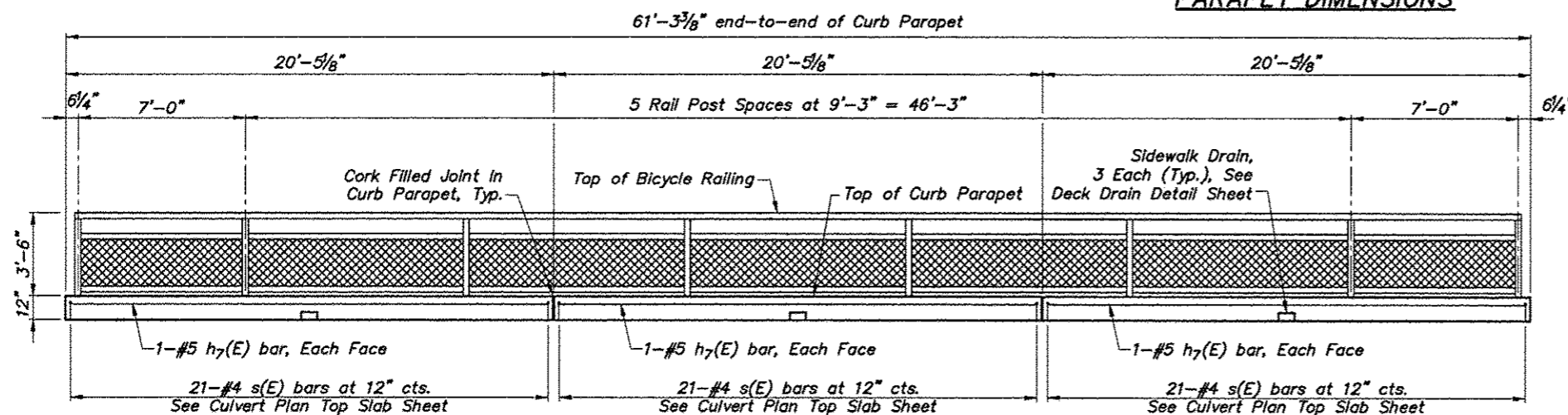

**CURB PARAPET ELEVATION**  
(Looking South at South Headwall with Bicycle Railing)

**PARAPET DETAILS AND  
RAIL POST SPACING  
HARRISON AVENUE  
OVER THE SOUTHEAST DRAINAGE WAY  
CITY OF ROCKFORD  
WINNEBAGO COUNTY  
STATION 143+74.0  
STRUCTURE No. 101-6105**

Sheet 15 of 19

**FEHR GRAHAM**

ENGINEERING & ENVIRONMENTAL

ILLINOIS DESIGN FIRM NO. 184-003525

© 2013 FEHR-GRAHAM

ILLINOIS  
IOWA  
WISCONSIN

**McClure**  
Engineering Associates, Inc.  
7282 Argus Drive  
Rockford, Illinois 61107-5837  
(815) 398-2332 FAX (815) 398-2496  
Design Firm License: Illinois 184-000816  
Copyright 2013 By McClure Engineering Associates, Inc.

PROJECT AND LOCATION  
HARRISON AVENUE  
RECONSTRUCTION 2012  
PHASE 1  
ROCKFORD, ILLINOIS

DRAWN BY: MS  
APPROVED BY: CTB  
DATE: 6/12/15  
SCALE: NA  
NA

| REVISIONS |             |      |
|-----------|-------------|------|
| REV. NO.  | DESCRIPTION | DATE |
|           |             |      |
|           |             |      |
|           |             |      |

DRAWING  
PARAPET DETAILS AND RAIL POST SPACING  
STRUCTURE NO. 101-6105

JOB NUMBER  
11-128

SHEET NUMBER  
388 of 588



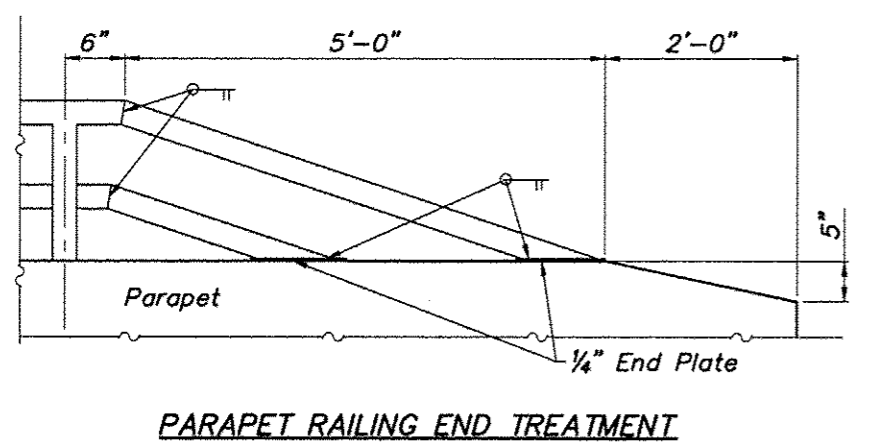
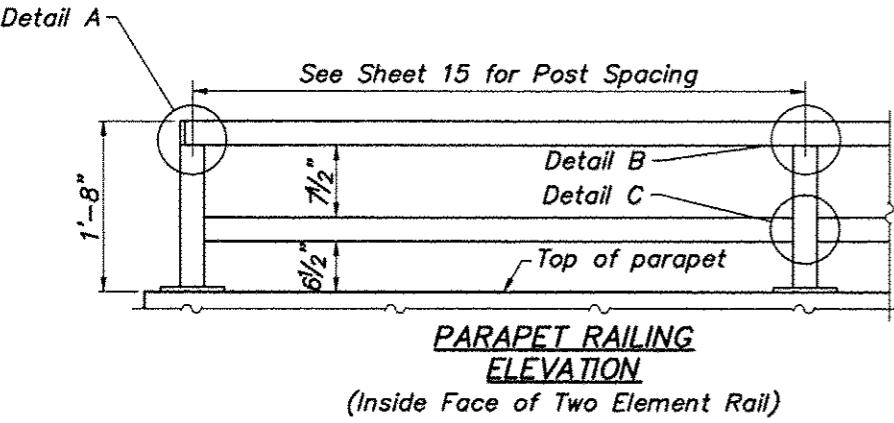
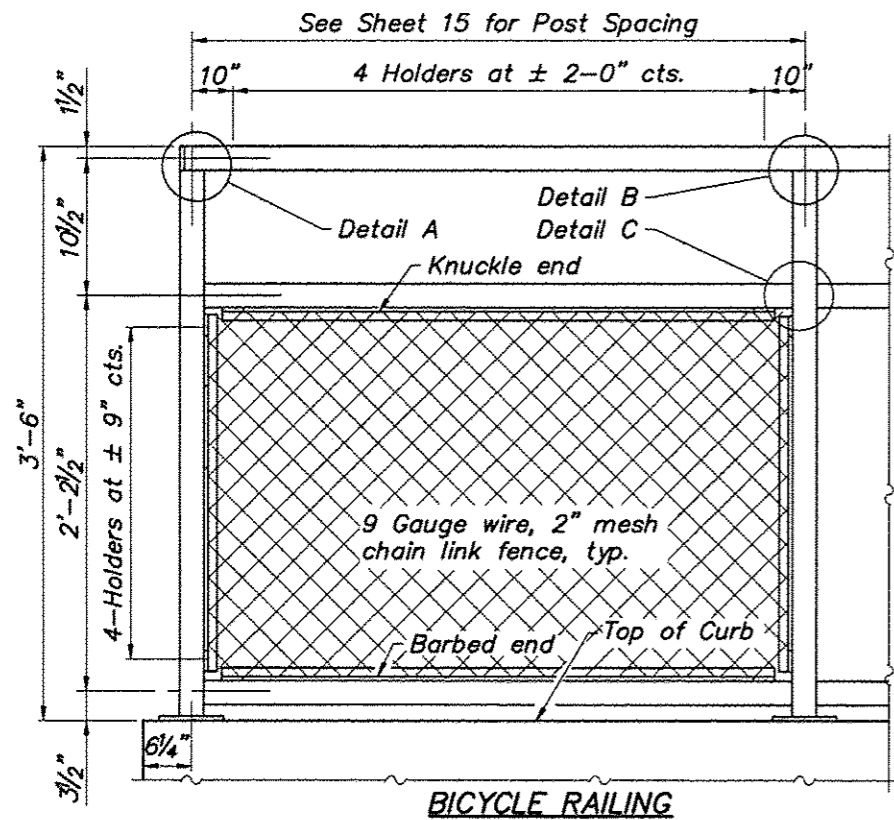

R-29 1-27-12 (10'-0" Maximum Post Spacing)

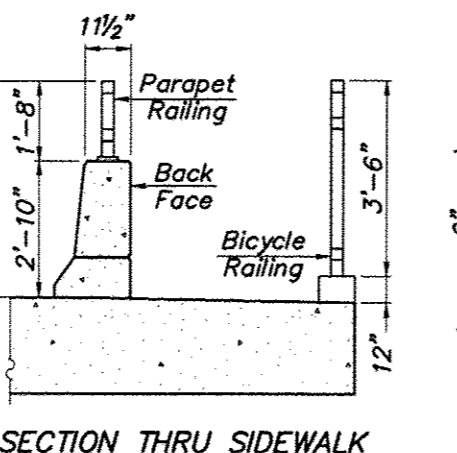
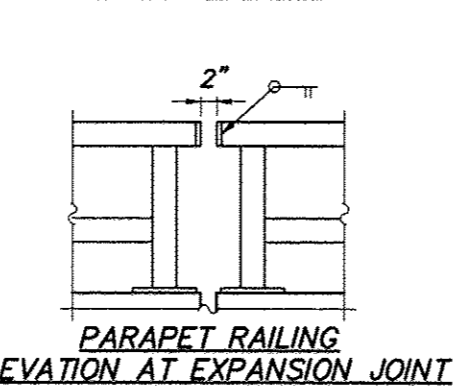
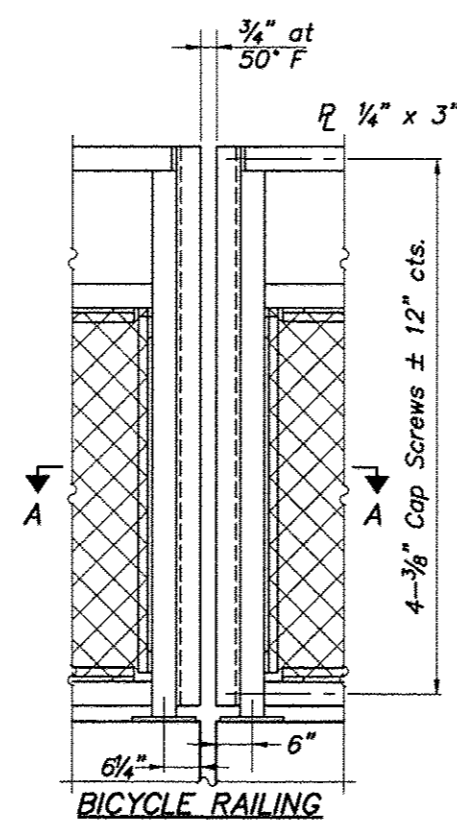

SECTION THRU SIDEWALK

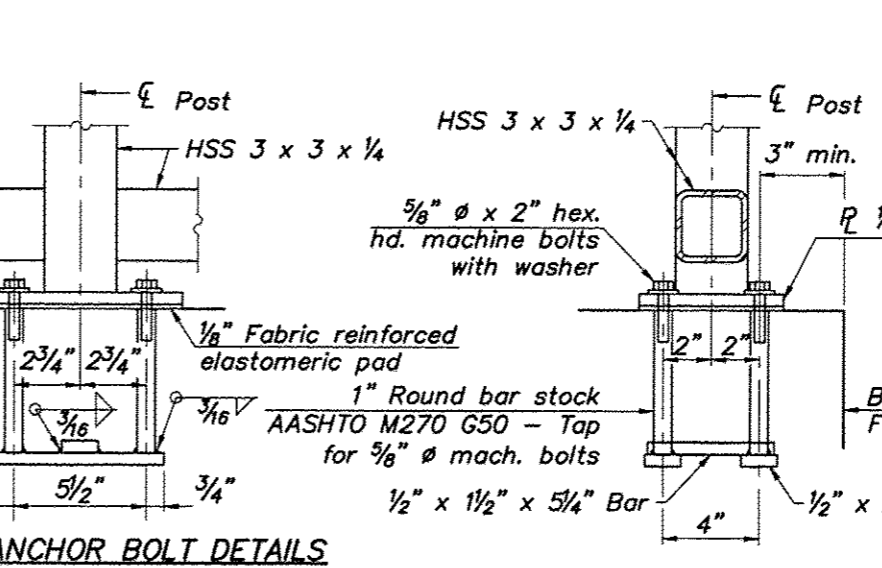
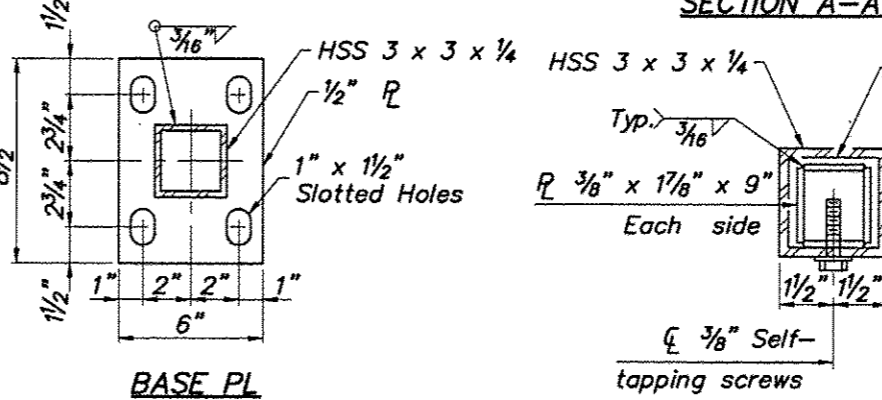
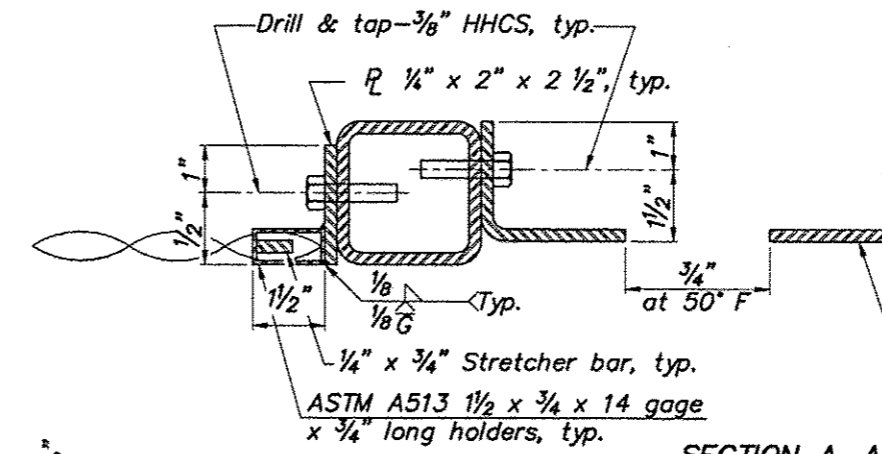
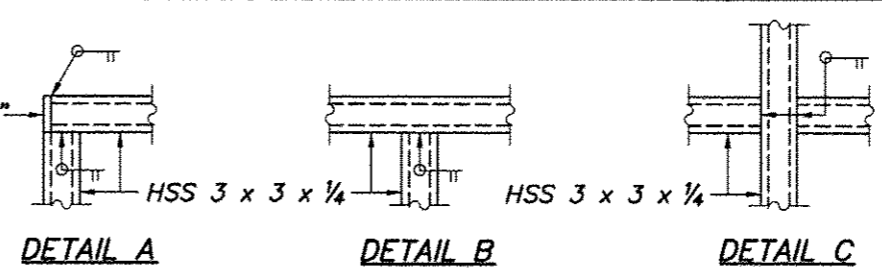

ANCHOR BOLT DETAILS  
In lieu of the cast-in-place anchor device shown, the Contractor has the option of drilling and setting 5/8" ø anchor rods according to Article 509.06 of the Standard Specifications. Embedment shall be according to the manufacturer's specifications.

All steel rail elements shall be galvanized according to Article 509.05 of the Standard Specifications.

**BILL OF MATERIAL**

| Item            | Unit | Quantity |
|-----------------|------|----------|
| Bicycle         | Foot | 61       |
| Parapet Railing | Foot | 175      |

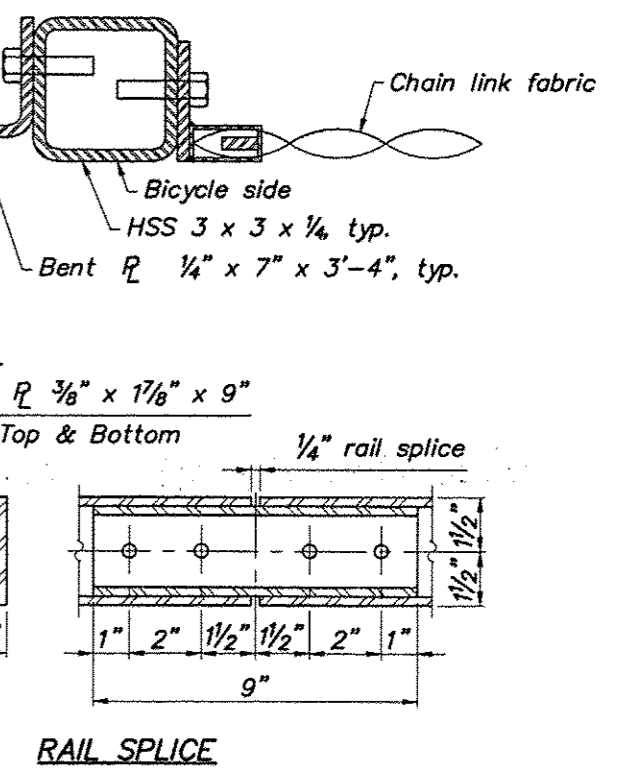

**BICYCLE RAILING DETAILS**  
HARRISON AVENUE  
OVER THE  
SOUTHEAST DRAINAGE WAY  
CITY OF ROCKFORD  
WINNEBAGO COUNTY  
STATION 143+74.0  
STRUCTURE No. 101-6105

Sheet 16 of 19

**NOTES:**

1. All cast iron parts shall be gray iron conforming to the requirements of AASHTO M 105, Class 35B.
2. Bolts, anchor studs, washers and nuts shall conform to the requirements of ASTM A 307 and shall be galvanized according to AASHTO M 232.
3. As an alternate, bolts, anchor studs, washers and nuts may be stainless steel according to Article 1006.29(d) of the Standard Specifications.
4. Structural steel weldments of equal sections and of the same configuration may be substituted for the cast iron scupper frame. Fillet or full penetration welds shall be used for the weldments. Details shall be submitted to the Engineer for approval. Structural steel weldments shall not be substituted for the cast iron scupper grate. Structural steel frames and downspouts shall be galvanized according to AASHTO M111.
5. The Contractor shall take appropriate measures to assure that Protective Coat is not applied to the scupper.
6. Cost of the Grate, Frame, Downspout, Anchor Studs, Bolts, Washers and Nuts including complete installation of the scupper shall be paid for at the contract unit price each for Drainage Scupper, DS-11.
7. Alternate fiberglass downspout conforming to ASTM D 2996 with a short-time rupture strength hoop tensile stress of 30,000 psi min. may be used in lieu of the cast iron or steel equivalent.
8. Downspouts are not required.

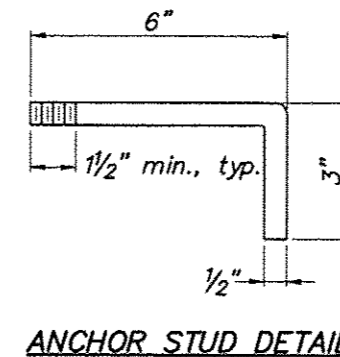
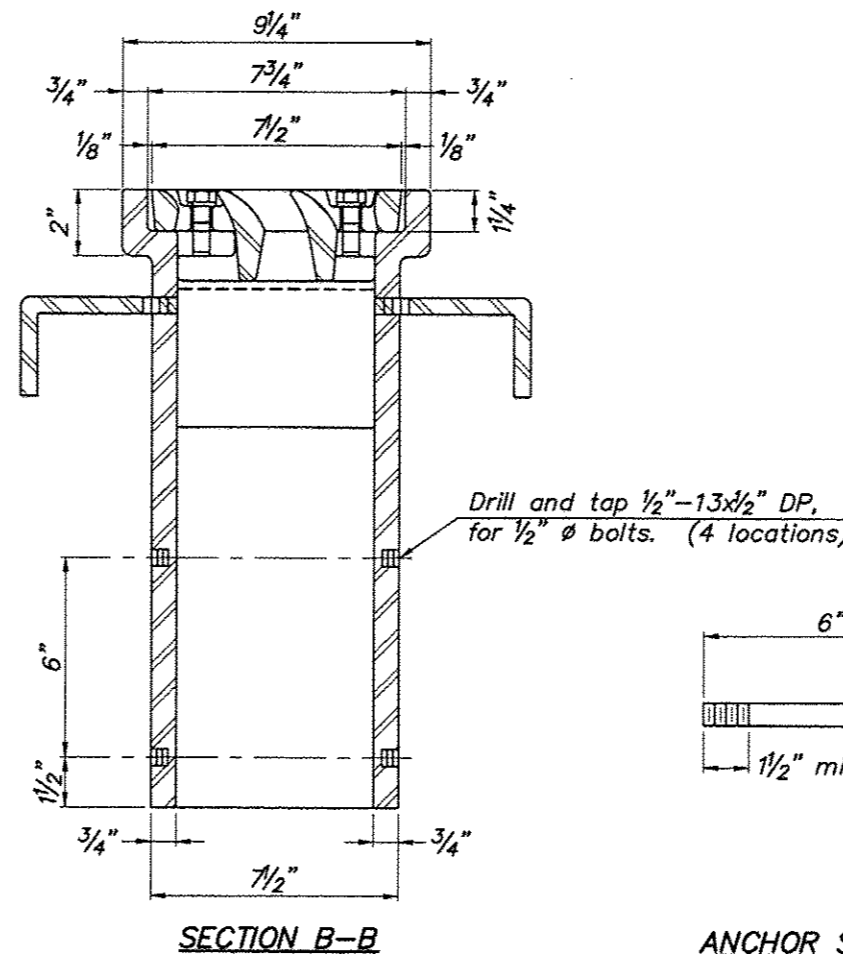
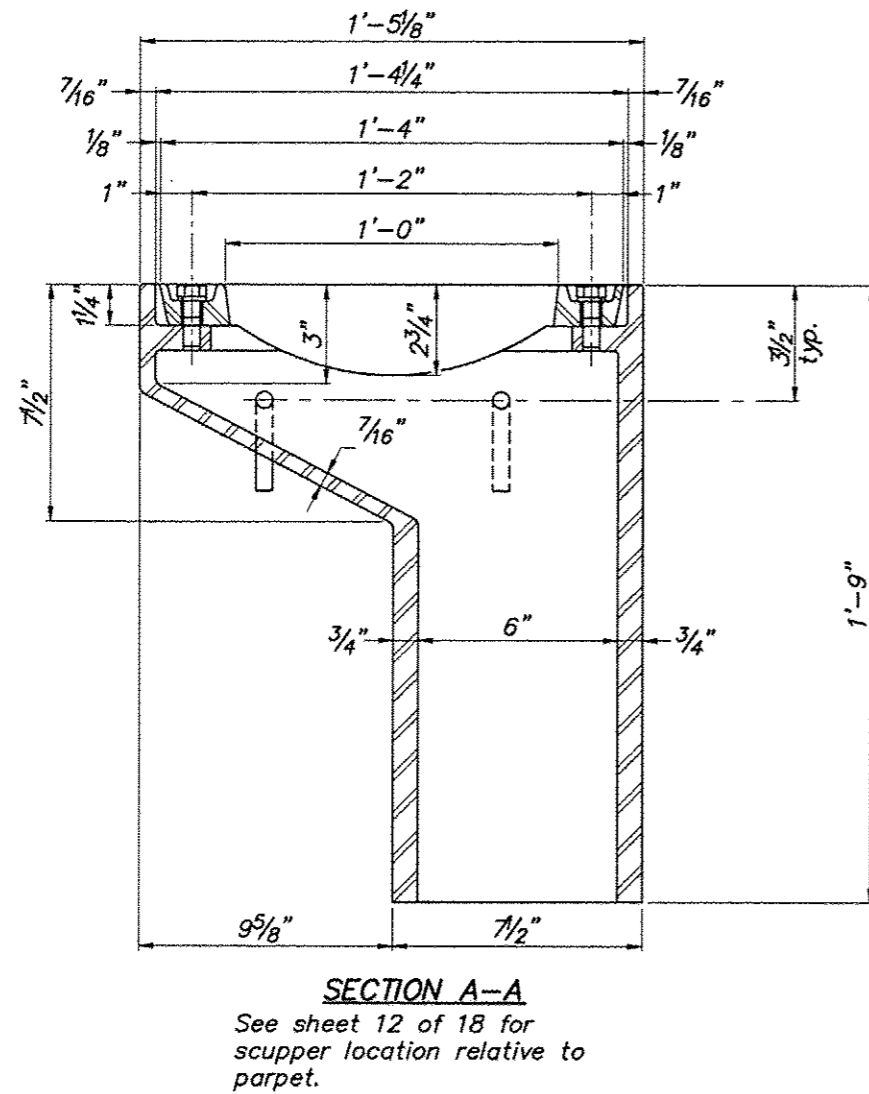
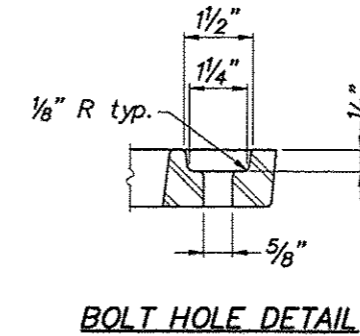
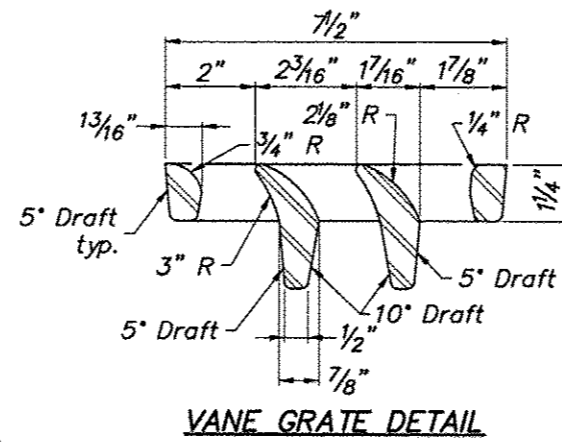
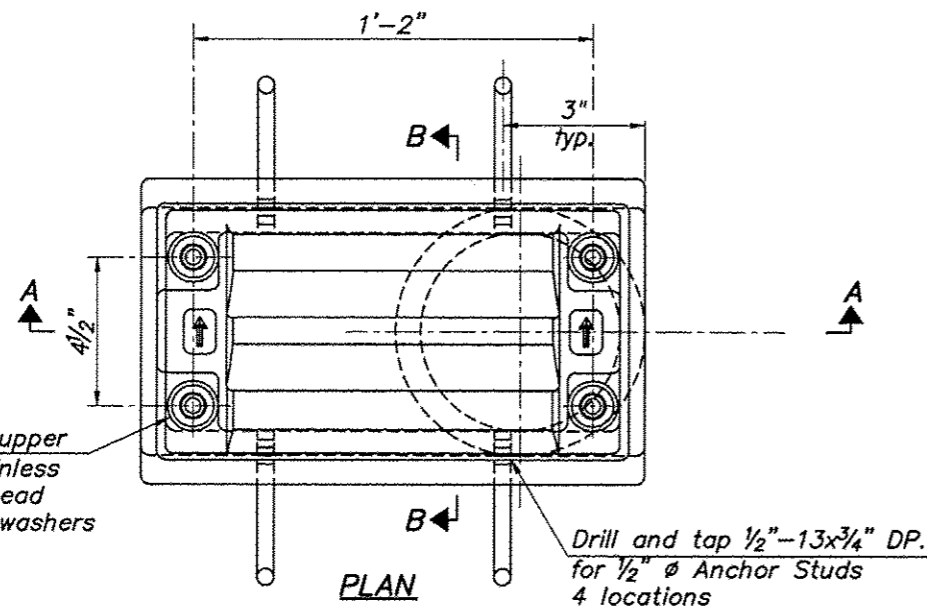

**BILL OF MATERIAL**

| ITEM                    | UNIT | QUANTITY |
|-------------------------|------|----------|
| Drainage Scupper, DS-11 | Each | 4        |

**DRAINAGE SCUPPER, DS-11**  
**HARRISON AVENUE**  
**OVER THE SOUTHEAST DRAINAGE WAY**  
**CITY OF ROCKFORD**  
**WINNEBAGO COUNTY**  
**STATION 143+74.0**  
**STRUCTURE No. 101-6105**

| REVISIONS |             |      |
|-----------|-------------|------|
| REV. NO.  | DESCRIPTION | DATE |
|           |             |      |
|           |             |      |
|           |             |      |

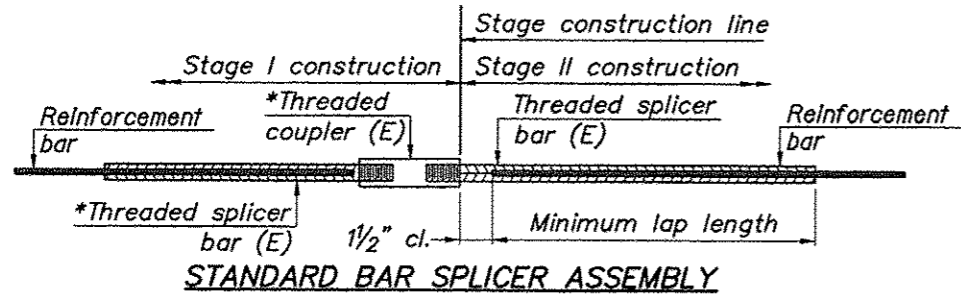

**STANDARD BAR SPLICER ASSEMBLY**

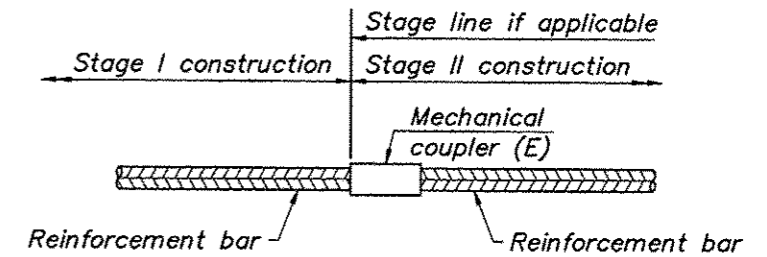

**STANDARD MECHANICAL SPLICER**

| Bar size to be spliced | Minimum Lap Lengths |         |         |         |         |         |
|------------------------|---------------------|---------|---------|---------|---------|---------|
|                        | Table 1             | Table 2 | Table 3 | Table 4 | Table 5 | Table 6 |
| 3, 4                   | 1'-5"               | 1'-11"  | 2'-1"   | 2'-4"   | 2'-7"   | 2'-11"  |
| 5                      | 1'-9"               | 2'-5"   | 2'-7"   | 2'-11"  | 3'-3"   | 3'-8"   |
| 6                      | 2'-1"               | 2'-11"  | 3'-1"   | 3'-6"   | 3'-10"  | 4'-5"   |
| 7                      | 2'-9"               | 3'-10"  | 4'-2"   | 4'-8"   | 5'-2"   | 5'-10"  |
| 8                      | 3'-8"               | 5'-1"   | 5'-5"   | 6'-2"   | 6'-9"   | 7'-8"   |
| 9                      | 4'-7"               | 6'-5"   | 6'-10"  | 7'-9"   | 8'-7"   | 9'-8"   |

- Table 1: Black bar, 0.8 Class C
- Table 2: Black bar, Top bar lap, 0.8 class C
- Table 3: Epoxy bar, 0.8 Class C
- Table 4: Epoxy bar, Top bar lap, 0.8 class C
- Table 5: Epoxy bar, Class C
- Table 6: Epoxy bar, Top bar top, Class C

Threaded slicer bar length = min. lap length + 1/2" + thread length

\* Epoxy not required on Bar Splicer Assembly components used in conjunction with black bars.

| Location          | Bar size | No. assemblies required | Table for minimum lap length |
|-------------------|----------|-------------------------|------------------------------|
| Bottom Slab       | #6       | 44                      | 3                            |
|                   | #5       | 44                      | 3                            |
| Top Slab          | #5       | 44                      | 3                            |
|                   | #6       | 44                      | 3                            |
| Interior Walls    | #5       | 18                      | 3                            |
| Exterior Walls    | #5       | 32                      | 3                            |
| Approach Footings | #5       | 160                     | 3                            |
| Approach Slabs    | #4       | 50                      | 3                            |
|                   | #5       | 92                      | 3                            |

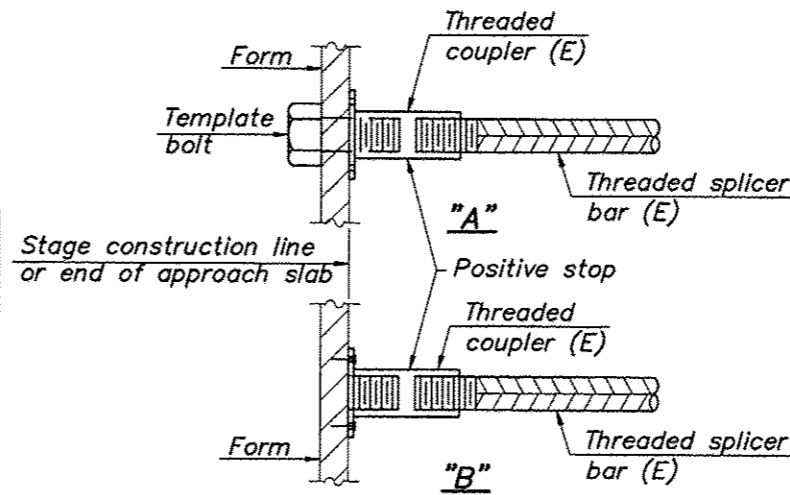

**INSTALLATION AND SETTING METHODS**

"A": Set bar splicer assembly by means of a template bolt.

"B": Set bar splicer assembly by nailing to wood forms or cementing to steel forms.

(E): Indicates epoxy coating.

| Location | Bar size | No. assemblies required |
|----------|----------|-------------------------|
|          |          |                         |
|          |          |                         |
|          |          |                         |
|          |          |                         |
|          |          |                         |

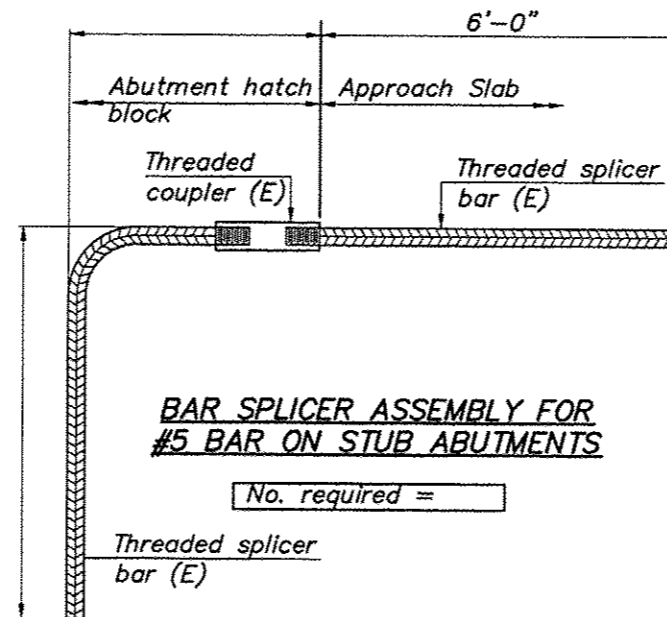

**BAR SPLICER ASSEMBLY FOR #5 BAR ON STUB ABUTMENTS**

No. required =

**NOTES**

- Splicer bars shall be deformed with threaded ends and have a minimum 60 ksi yield strength.
- All reinforcement shall be lapped and tied to the splicer bars.
- Bar splicer assemblies shall be epoxy coated according to the requirements for reinforcement bars. See Section 508 of the Standard Specifications.
- See approved list of bar splicer assemblies and mechanical splicers for alternatives.

**BAR SPLICER ASSEMBLY  
HARRISON AVENUE  
OVER THE SOUTHEAST DRAINAGE WAY  
CITY OF ROCKFORD  
WINNEBAGO COUNTY  
STATION 143+74.0  
STRUCTURE No. 101-6105**

BSD-1 8-31-12

Sheet 18 of 19

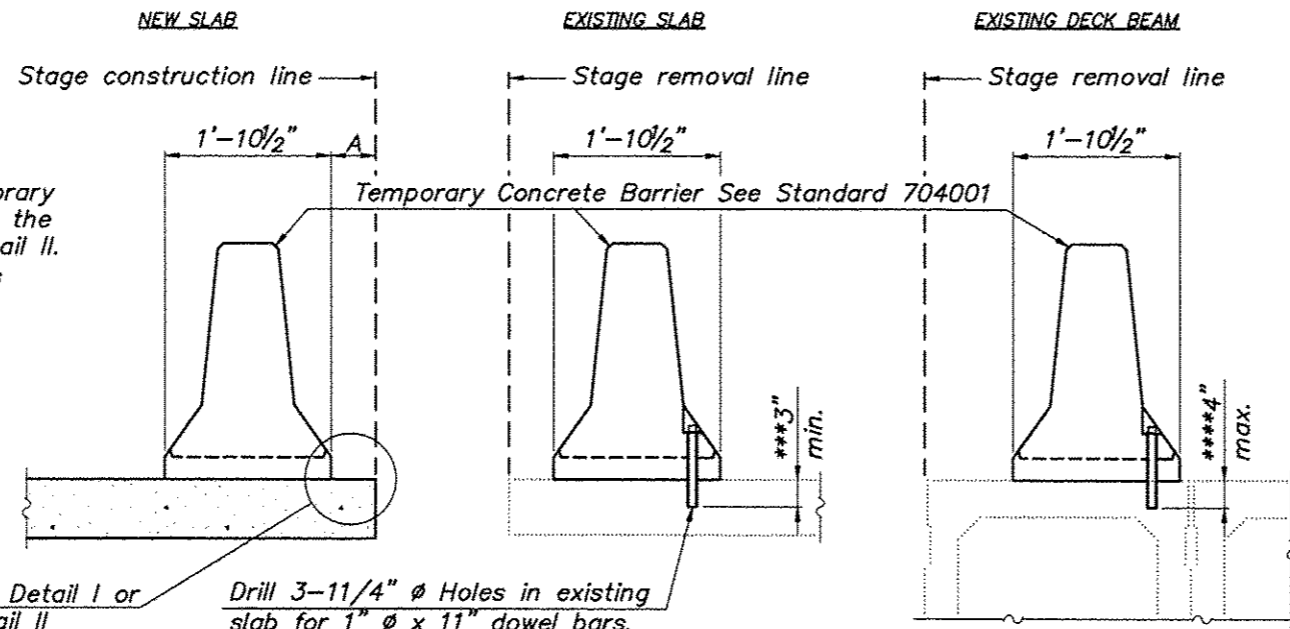

When "A" is 3'-6" or less, the temporary concrete barrier shall be anchored to the new slab according to Detail I or Detail II. No anchorage is required when "A" is greater than 3'-6".

See Detail I or Detail II  
 Drill 3-11/4"  $\phi$  Holes in existing slab for 1"  $\phi$  x 11" dowel bars. Traffic side only Cost included with Temporary Concrete Barrier.

**SECTIONS THRU SLAB OR DECK BEAM**

**NOTES**

Detail I - With Bar Splicer or Couplers:  
 Connect one (1) 1" x 7" "W" steel  $\epsilon$  to the top layer of couplers with 2-5/8"  $\phi$  bolts screwed to coupler at approximate  $\epsilon$  of each barrier panel.

Detail II - With Extended Reinforcement Bars:  
 Connect one (1) 1" x 7" "W" steel  $\epsilon$  to the concrete slab or concrete wearing surface with 2-5/8"  $\phi$  Expansion Anchors or cast in place inserts spaced between the top layer of reinforcement at approximate  $\epsilon$  of each barrier panel.

Cost of anchorage is included with Temporary Concrete Barrier. The 1" x 7" x "W" plate shall not be removed until stage II Construction forms and all reinforcement bars are in place and the concrete is ready to be placed.

\*\*\* Dimension shown is minimum required embedment into concrete. If hot-mix asphalt wearing surface is present, minimum embedment shall be in addition to wearing surface depth.

\*\*\*\* If existing deck beam is to remain in place after stage construction, embedment shall only be into wearing surface and not into existing deck beam concrete.

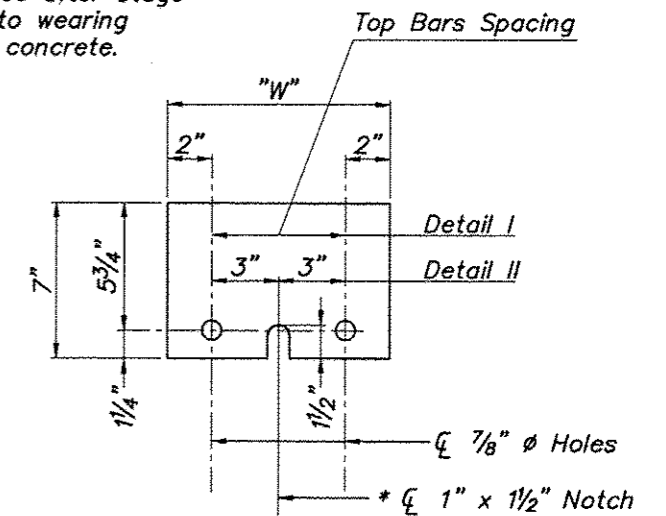
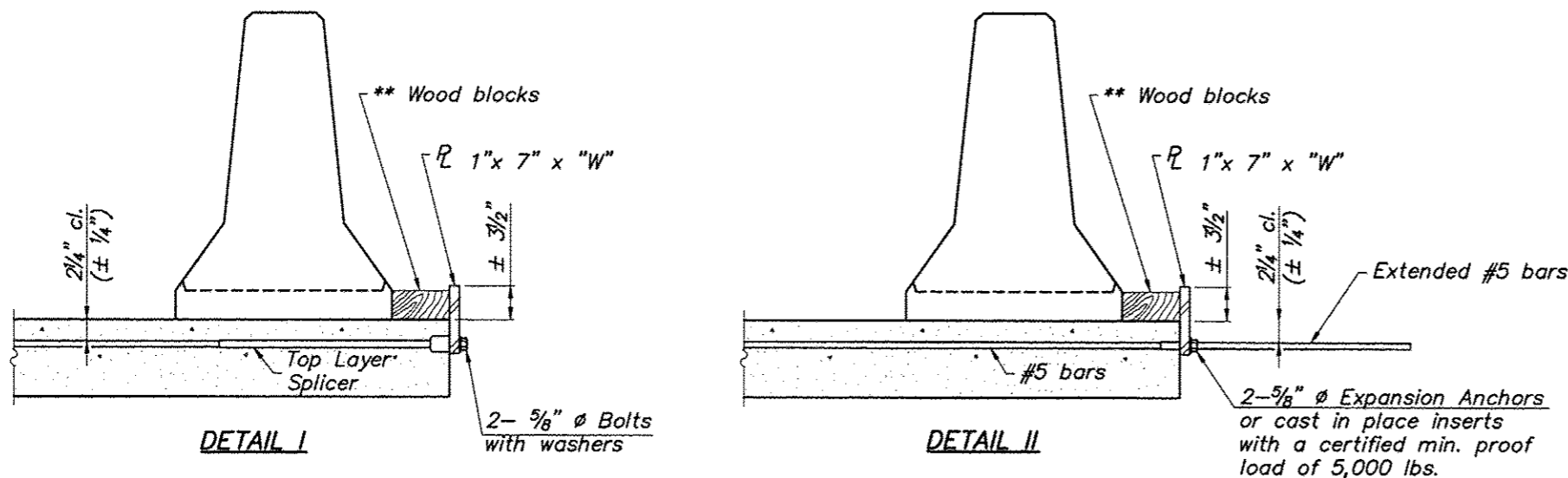

**STEEL RETAINER 1" X 7" X "W"**  
 \* Required only with Detail II

\*\* Wood blocks may be omitted when required to provide minimum stage traffic lane width. When the wood blocks are omitted, the concrete barrier shall be in direct contact with the steel retainer plate.

"W" = Top bars spacing + 4"

**TEMPORARY BARRIER  
 HARRISON AVENUE  
 OVER THE SOUTHEAST DRAINAGE WAY  
 CITY OF ROCKFORD  
 WINNEBAGO COUNTY  
 STATION 143+74.0  
 STRUCTURE No. 101-6105**

R-27 7-1-10

Sheet 19 of 19

**FEHR GRAHAM**

ENGINEERING & ENVIRONMENTAL

ILLINOIS DESIGN FIRM NO. 184-003523

© 2013 FEHR-GRAHAM

ILLINOIS  
 IDWA  
 WISCONSIN

**McClure**  
 Engineering Associates, Inc.  
 7287 Argus Drive Rookford, Illinois 61107-5837  
 (815) 398-2532 FAX (815) 398-2498  
 Design Firm License: Illinois 184-000816  
 Copyright 2013 By McClure Engineering Associates, Inc.

PROJECT AND LOCATION  
 HARRISON AVENUE  
 RECONSTRUCTION 2012  
 PHASE 1  
 ROCKFORD, ILLINOIS

DRAWN BY: MS  
 APPROVED BY: CTB  
 DATE: 6/12/15  
 SCALE: NA  
 NA

| REVISIONS |             |      |
|-----------|-------------|------|
| REV. NO.  | DESCRIPTION | DATE |
|           |             |      |
|           |             |      |
|           |             |      |

DRAWING  
 TEMPORARY BARRIER  
 STRUCTURE NO. 101-6105

JOB NUMBER  
 11-128

SHEET NUMBER  
 392 of 588

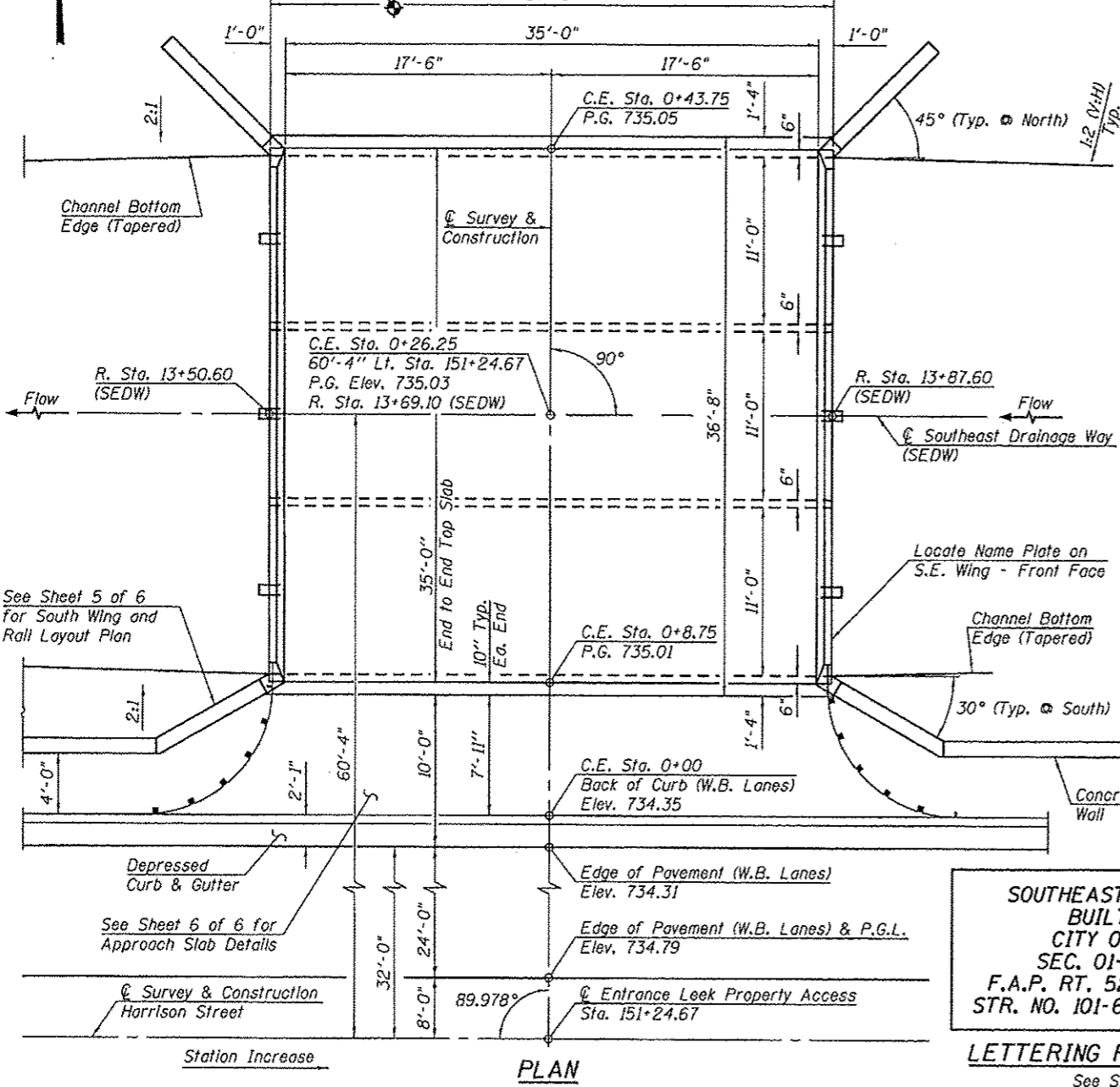
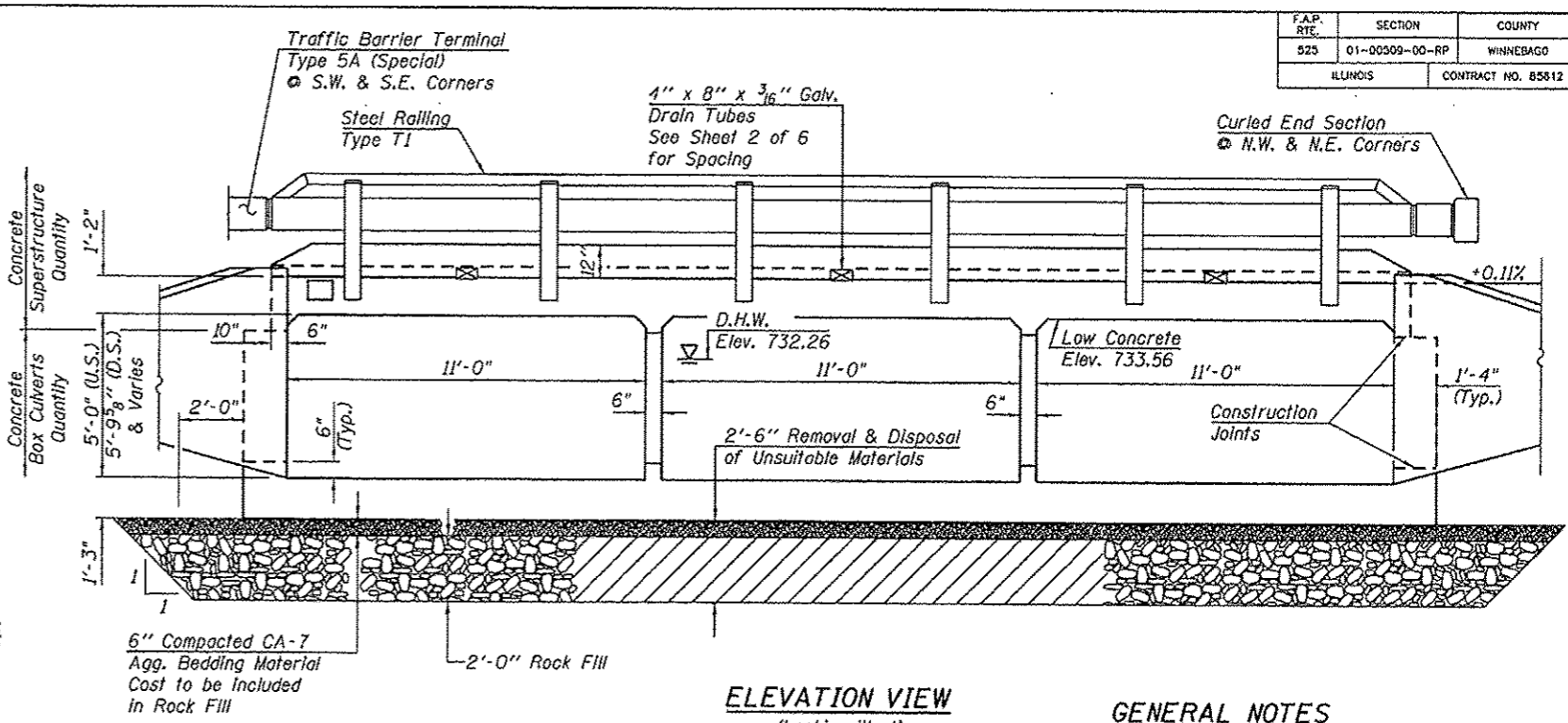
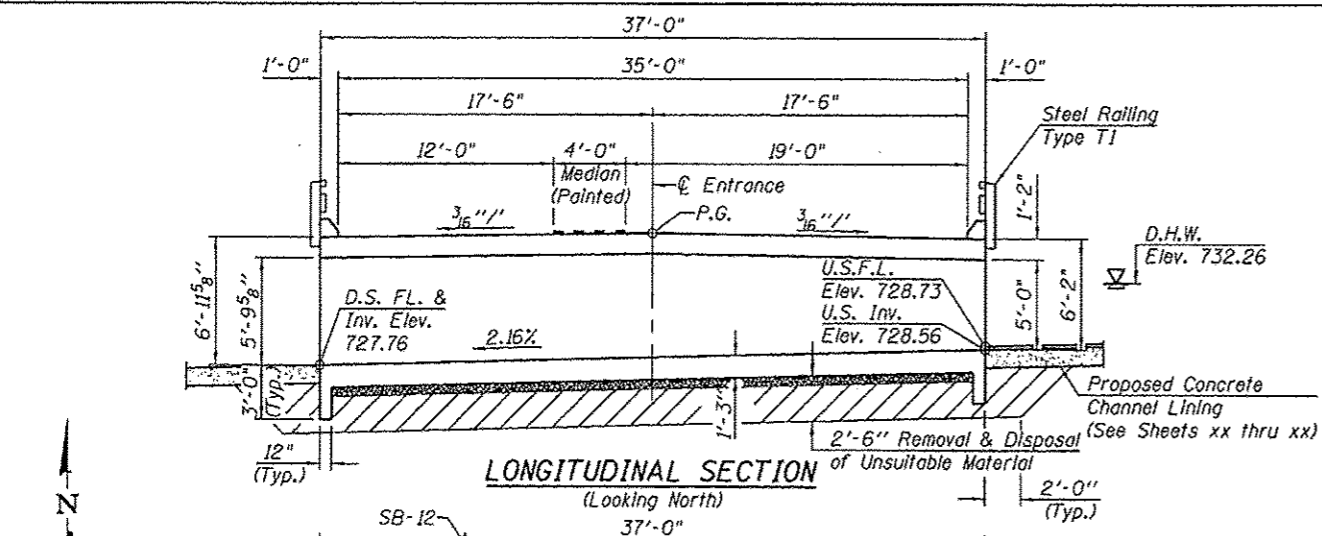

**WATERWAY INFORMATION**

Drainage Area ..... ( \* Yr. ) ..... 2.57 Sq. Mi.  
 Existing Opening (Bridge) ..... ( \* Yr. ) ..... N/A Sq. Ft.  
 Required Opening ..... ( \* Yr. ) ..... 116 Sq. Ft.  
 Proposed Opening (Bridge) ..... ( \* Yr. ) ..... 116 Sq. Ft.  
 Design Discharge ..... ( \* Yr. ) ..... 1125 C.F.S.  
 Existing Created Head ..... ( \* Yr. ) ..... 1.87 Ft.  
 Proposed Created Head ..... ( \* Yr. ) ..... 1.39 Ft.

\* Existing Channel Capacity

**INDEX OF SHEETS**

1. General Plan & Elevation
2. Culvert Elevation Details
3. Culvert Plan Details
4. Steel Railing Type T-1
5. Steel Railing Details
6. Approach Slab Details

**GENERAL NOTES**

Reinforcement bars shall conform to the requirements of ASTM A706 Grade 60.

Reinforcement bars designated (E) shall be epoxy coated.

A Precast Concrete Culvert alternate will not be allowed.

Exposed portions of wingwalls & curbs shall receive a rubbed finish in accordance with Article 503.15(b) of Standard Specifications. Cost shall be included in cost for Concrete Box Culverts.

**DESIGN STRESSES**

**FIELD UNITS**

$f_c = 3,500$  psi  
 $f_y = 60,000$  psi (Reinforcement)

**DESIGN SPECIFICATIONS**

AASHTO LRFD Bridge Design Specifications, 6th Edition 2012 & 2013 Interim Revisions

**LOADING HL-93**

Allow 50#/sq. ft. for future wearing surface.

**DESIGN SCOUR ELEVATION TABLE**

| Design Scour Elevation (ft.) | Upstream | Downstream |
|------------------------------|----------|------------|
|                              | 725.56   | 724.76     |

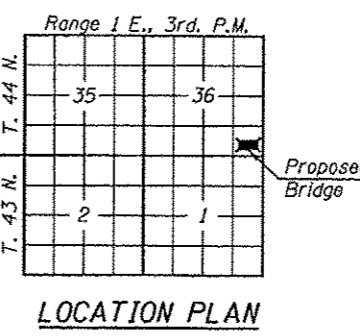

**SOUTHEAST DRAINAGE WAY BUILT 201\_ BY CITY OF ROCKFORD SEC. 01-00509-00-RP F.A.P. RT. 525 STA. 151+24.67 STR. NO. 101-6106 LOADING HL-93**

"I certify that to the best of my knowledge, information and belief, this bridge design is structurally adequate for the design loading shown on the plans. The design is an economical one for the style of structure and complies with requirements of the specified 'AASHTO LRFD Bridge Design Specifications'."

*John A. Morris* 6/11/15  
 ILLINOIS STRUCTURAL NO. 4277 (Expires 11/30/16)



**GENERAL PLAN & ELEVATION C.E. OVER SOUTHEAST DRAINAGE WAY SECTION 01-00509-00-RP CITY OF ROCKFORD, ILLINOIS WINNEBAGO COUNTY LT. STA. 151+24.67 (HARRISON AVE.) S.N. 101-6106**

**LETTERING FOR NAME PLATE**  
 See Std. 515001

**REVISIONS**

| NO. | DESCRIPTION |
|-----|-------------|
|     |             |
|     |             |
|     |             |

\*For placement of interior wall reinforcement see Interior Wall Reinforcement Bar Placement Detail.

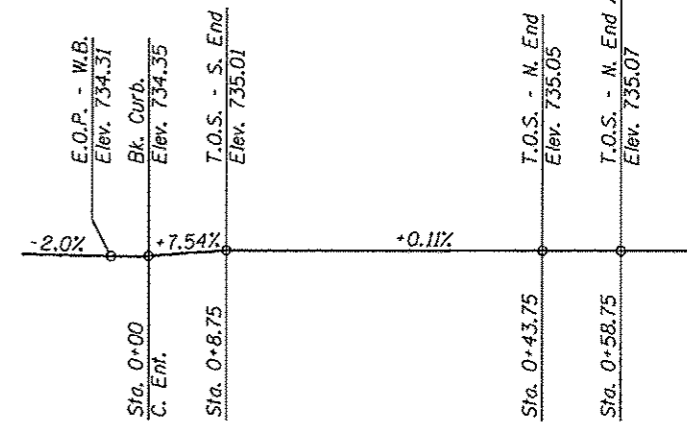
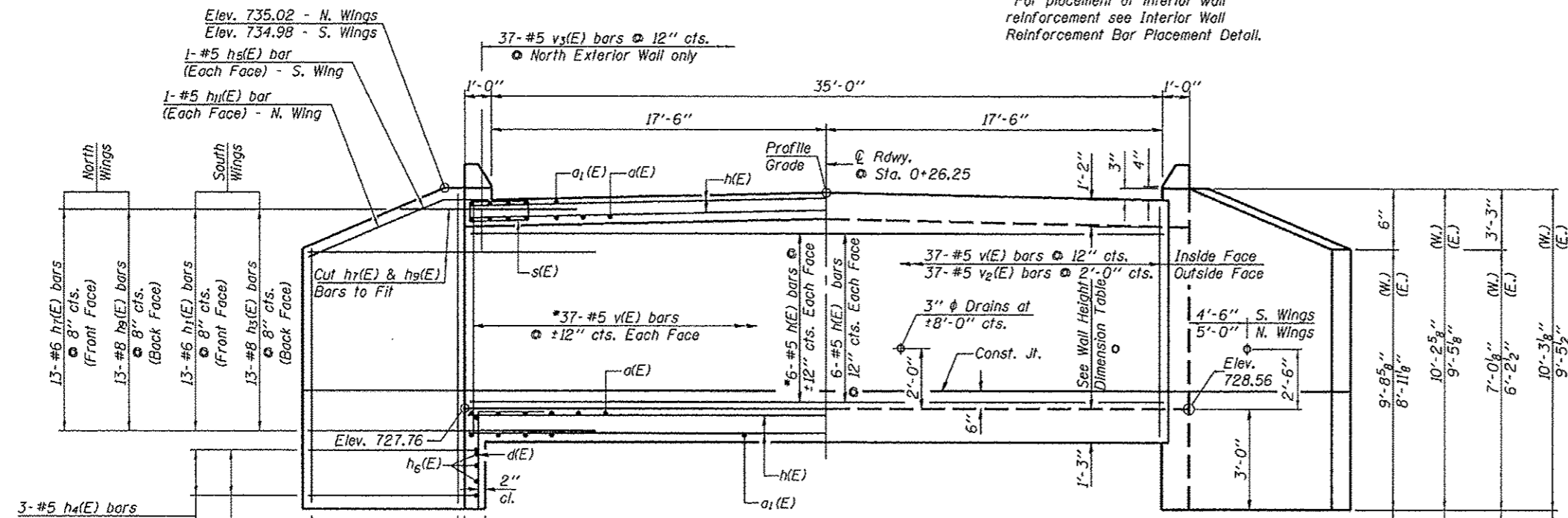

- 13- #6 h(E) bars @ 8" cts. (Front Face) - North Wings
- 13- #6 h(E) bars @ 8" cts. (Back Face) - North Wings
- 13- #6 h(E) bars @ 8" cts. (Front Face) - South Wings
- 13- #6 h(E) bars @ 8" cts. (Back Face) - South Wings
- 1- #5 h(E) bar (Each Face) - S. Wing
- 1- #5 h(E) bar (Each Face) - N. Wing
- 3- #5 h(E) bars @ 9" cts. (Front Face) - S. Wings
- 3- #5 h(E) bars @ 9" cts. (Front Face) - N. Wings
- 3- #8 h(E) bars @ 8" cts. (Back Face) - S. Wings
- 3- #8 h(E) bars @ 8" cts. (Back Face) - N. Wings
- 10- #4 v(E) bars @ 11" cts. (S. Wings)
- 11- #4 v(E) bars @ 11" cts. (N. Wings)
- 11- #4 v(E) bars @ 11" cts. Ea. Face Cut to Fit

**HALF LONG. SECTION**  
Showing bars in Center Walls (Looking North)

**HALF ELEVATION**  
Showing bars in Outside Wall

**BARREL HEIGHT & TOP OF WALL ELEV. TABLE**

| Location | West End                            |        | C. Constr.                         |        | East End                           |        |
|----------|-------------------------------------|--------|------------------------------------|--------|------------------------------------|--------|
|          | Height                              | Elev.  | Height                             | Elev.  | Height                             | Elev.  |
| A        | 5'-9 <sup>5</sup> / <sub>8</sub> "  | 733.06 | 5'-8 <sup>1</sup> / <sub>2</sub> " | 733.34 | 5'-0"                              | 733.06 |
| B        | 5'-9 <sup>3</sup> / <sub>4</sub> "  | 733.07 | 5'-8 <sup>1</sup> / <sub>4</sub> " | 733.35 | 5'-0 <sup>1</sup> / <sub>8</sub> " | 733.07 |
| C        | 5'-10"                              | 733.09 | 5'-8 <sup>1</sup> / <sub>2</sub> " | 733.37 | 5'-0 <sup>3</sup> / <sub>8</sub> " | 733.09 |
| D        | 5'-10 <sup>1</sup> / <sub>8</sub> " | 733.10 | 5'-8 <sup>5</sup> / <sub>8</sub> " | 733.38 | 5'-0 <sup>1</sup> / <sub>2</sub> " | 733.10 |

Note: Wingwall Concrete is included in Concrete Box Culverts quantity.

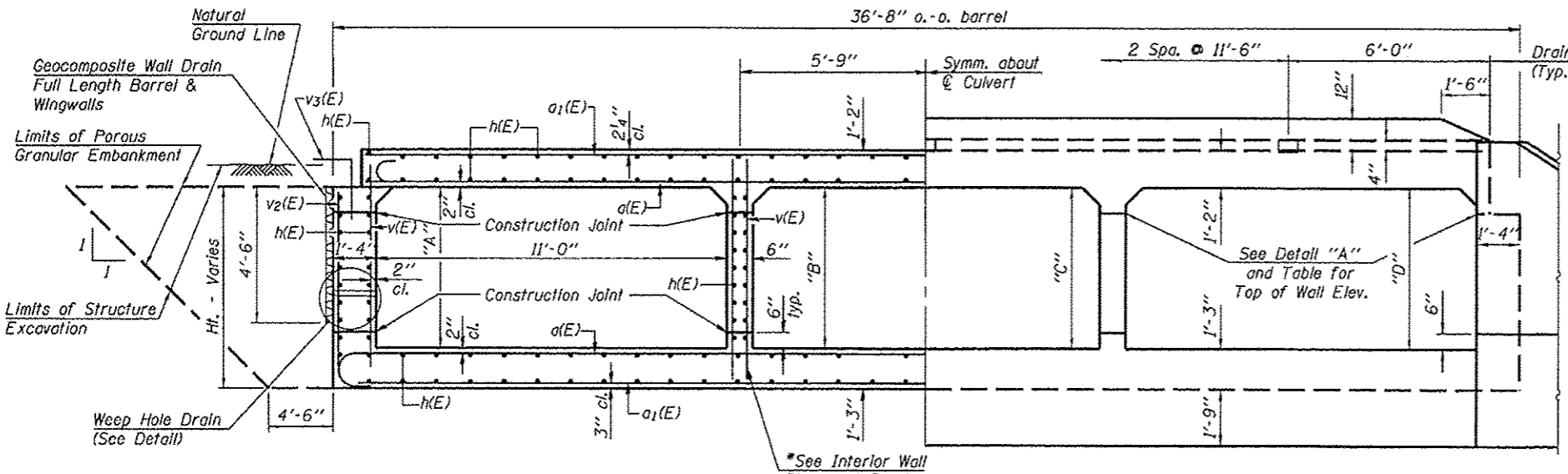
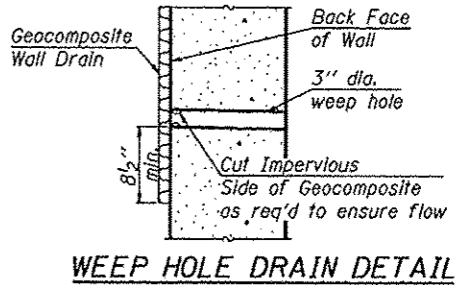
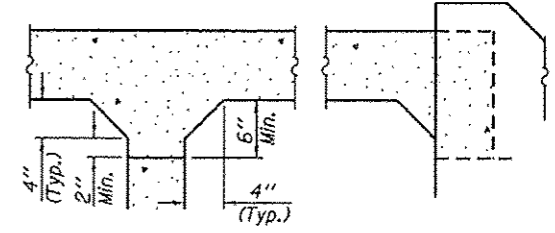

**HALF SECTION THRU BARREL**  
(Looking West)

**HALF END ELEVATION**

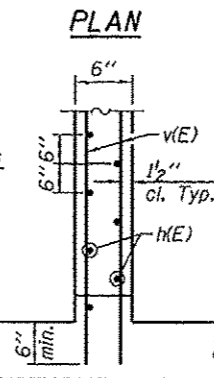
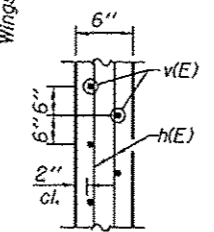

**INTERIOR WALL REINFORCEMENT BAR PLACEMENT DETAIL**

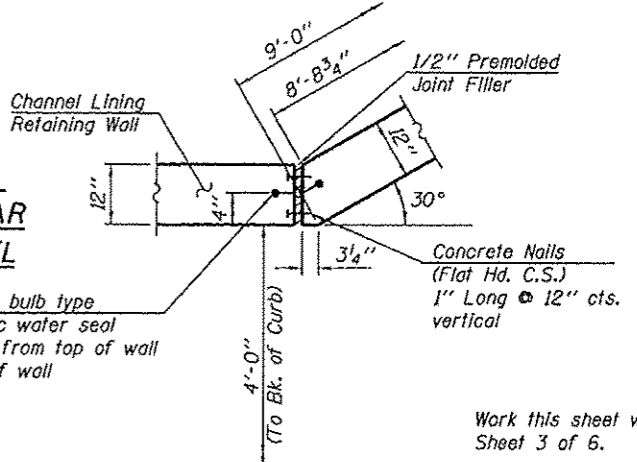

**S. WING END DETAIL**  
(S.W. Wing Shown)

Work this sheet with Sheet 3 of 6.

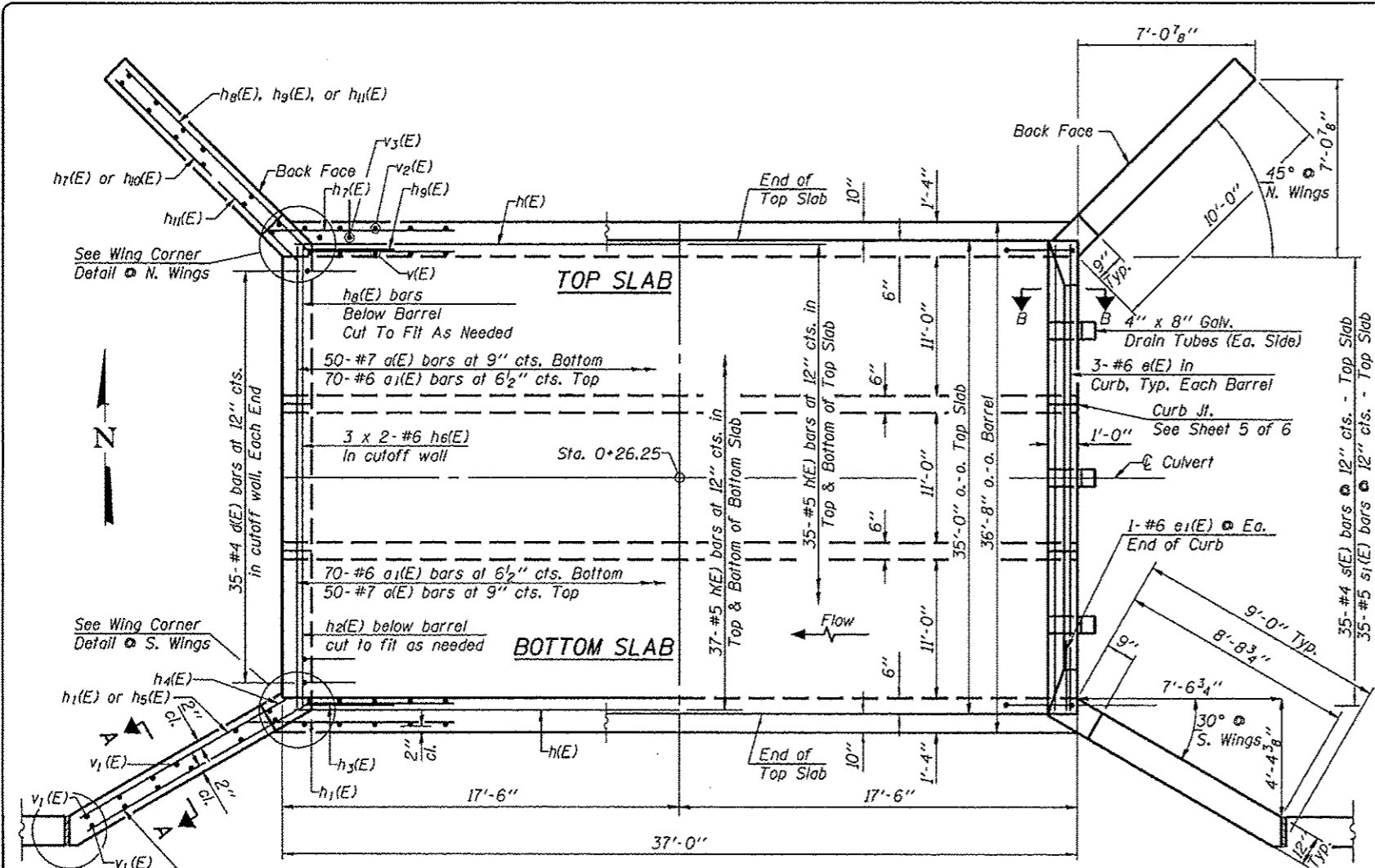

**SHOWING REINFORCEMENT**      **SHOWING OUTLINES**

**MIN. BAR LAPS**  
 #5 bar = 2'-7"  
 #6 bar = 3'-1"

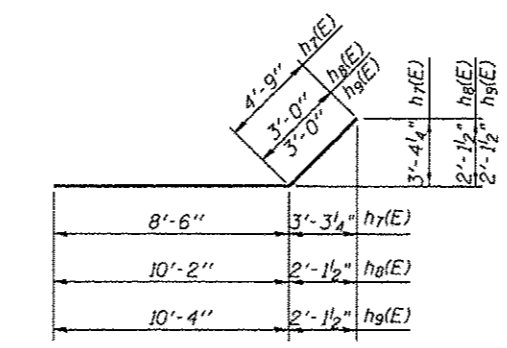
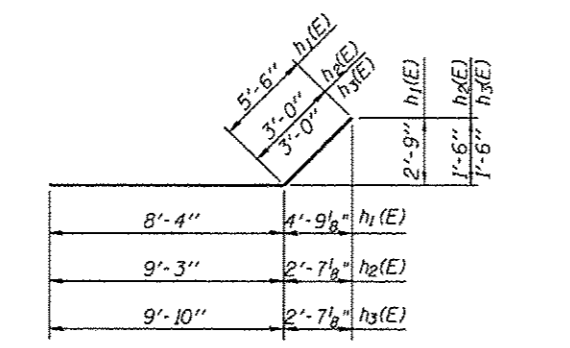
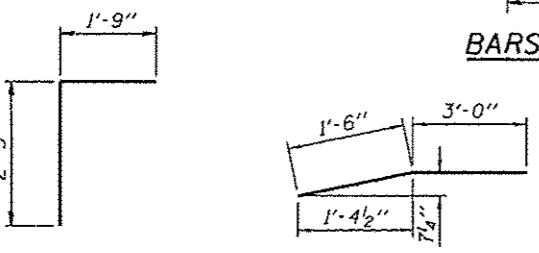
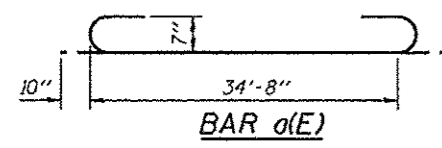

**BAR d(E)**

**BAR e1(E)**

**BARS h1(E), h2(E), & h3(E)**  
 (S. Wings)

**BARS h7(E), h8(E), & h9(E)**  
 (N. Wings)

**BAR v3(E)**

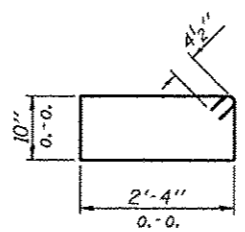

**BAR s(E)**

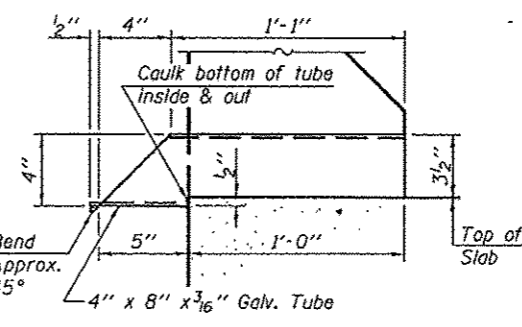

**DRAIN DETAIL**

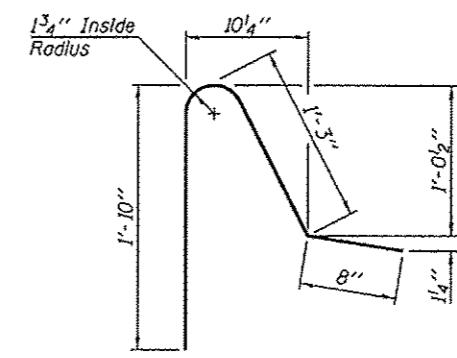

**BAR s1(E)**

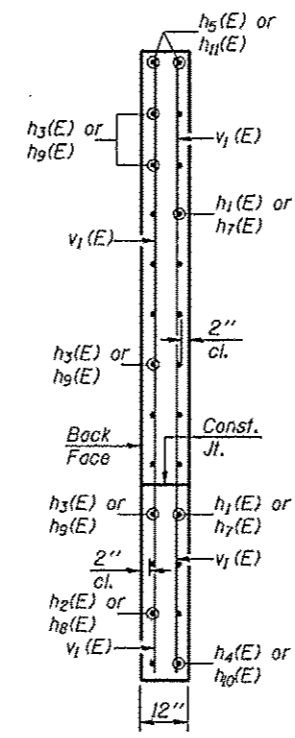

**SECTION A-A**

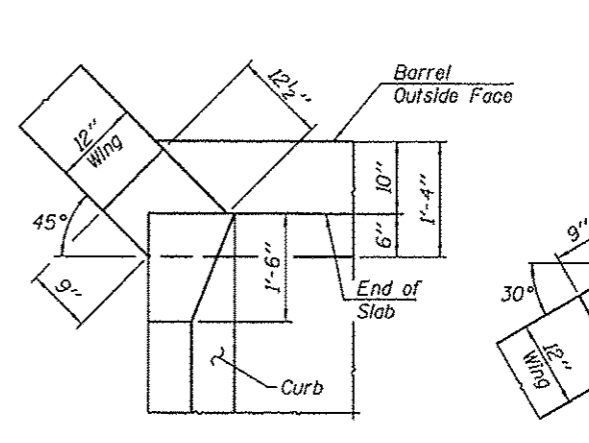

**WING CORNER**  
 (North Wings - N.W. Corner Shown)

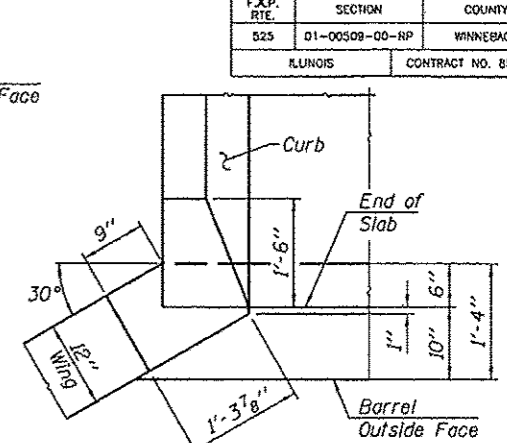

**WING CORNER**  
 (South Wings - S.W. Corner Shown)

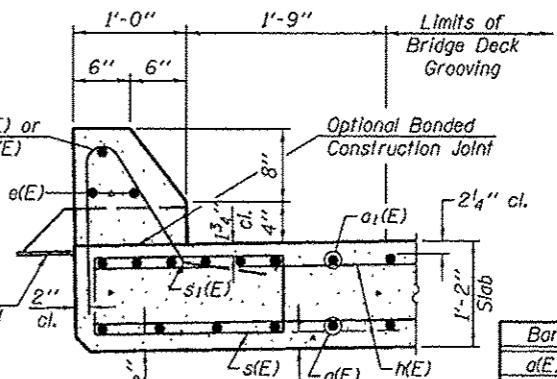

**SECTION B-B**

Place e(E) & e1(E) bars directly over Rail Post Anchors.  
 Place 4-a(E) bars bottom and 6-a1(E) bars top within s(E) bars.

**BILL OF MATERIAL**

| Bar                              | No. | Size    | Length  | Shape |
|----------------------------------|-----|---------|---------|-------|
| a(E)                             | 100 | #7      | 36'-4"  | U     |
| a1(E)                            | 140 | #6      | 34'-8"  | U     |
| d(E)                             | 70  | #4      | 4'-6"   | L     |
| e(E)                             | 18  | #6      | 11'-2"  | U     |
| e1(E)                            | 4   | #6      | 4'-6"   | L     |
| h(E)                             | 192 | #5      | 36'-8"  | U     |
| h1(E)                            | 26  | #6      | 13'-10" | U     |
| h2(E)                            | 6   | #8      | 12'-3"  | U     |
| h3(E)                            | 26  | #8      | 12'-10" | U     |
| h4(E)                            | 6   | #5      | 8'-9"   | U     |
| h5(E)                            | 4   | #5      | 8'-11"  | U     |
| h6(E)                            | 12  | #6      | 19'-9"  | U     |
| h7(E)                            | 26  | #6      | 13'-3"  | U     |
| h8(E)                            | 6   | #8      | 13'-2"  | U     |
| h9(E)                            | 26  | #8      | 13'-4"  | U     |
| h10(E)                           | 6   | #5      | 9'-9"   | U     |
| h11(E)                           | 4   | #5      | 9'-11"  | U     |
| s(E)                             | 70  | #4      | 7'-1"   | U     |
| s1(E)                            | 70  | #5      | 3'-9"   | U     |
| v(E)                             | 222 | #5      | 7'-1"   | U     |
| v1(E)                            | 88  | #4      | 10'-0"  | U     |
| v2(E)                            | 38  | #5      | 6'-8"   | U     |
| v3(E)                            | 37  | #5      | 4'-0"   | L     |
| Concrete Superstructure          |     | Cu. Yd. | 60.2    |       |
| Concrete Box Culverts            |     | Cu. Yd. | 105.3   |       |
| Reinforcement Bars, Epoxy Coated |     | Pound   | 29,680  |       |
| Protective Coat                  |     | Sq. Yd. | 153     |       |
| Bridge Deck Grooving             |     | Sq. Yd. | 128     |       |
| Geocomposite Wall Drain          |     | Sq. Yd. | 50      |       |

Work this sheet with sheet 2 of 6.

| REVISIONS |  |
|-----------|--|
|           |  |
|           |  |
|           |  |
|           |  |

Notes:  
 All field drilled holes shall be coated with an approved zinc rich paint before erection.  
 All steel rail elements shall be galvanized according to Article 509.05 of the Standard Specifications.  
 \*\* The studs of the anchor devices shall be placed below the top longitudinal reinforcement bar in the curb.

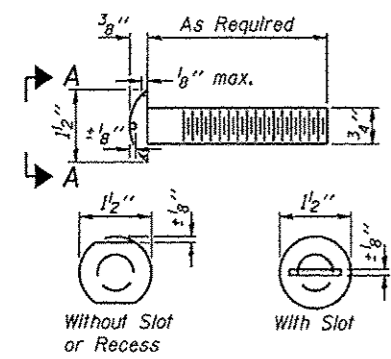

**VIEW A-A  
ROUND HEAD BOLT**

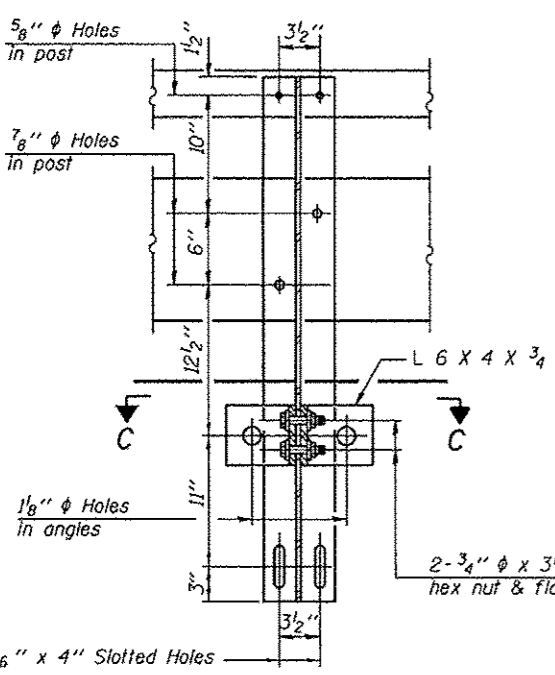

**SECTION B-B**

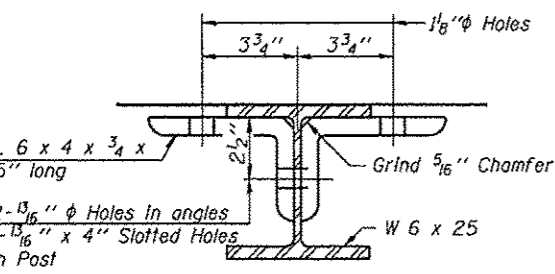

**SECTION C-C**

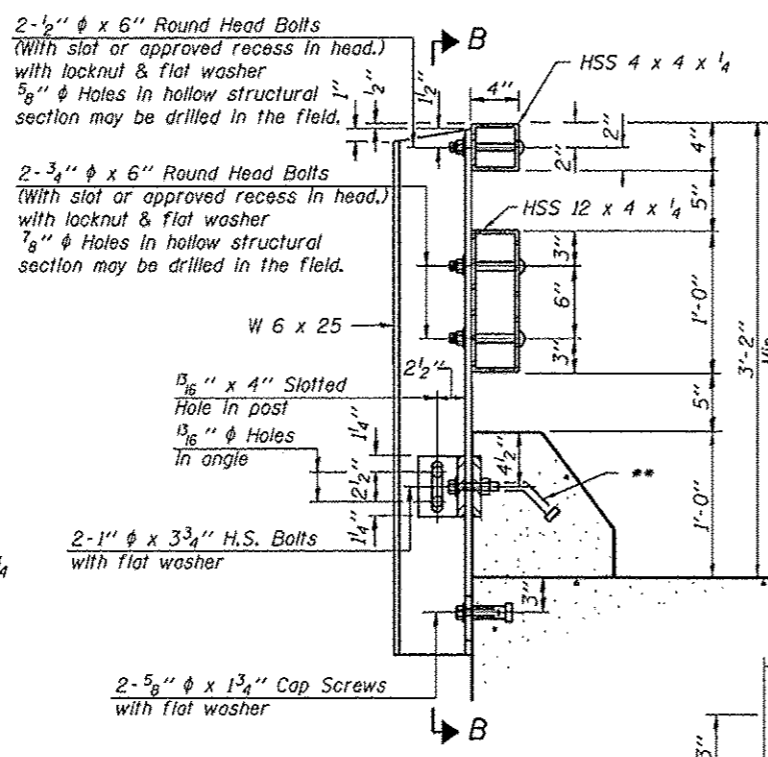

**SECTION AT RAIL POST**

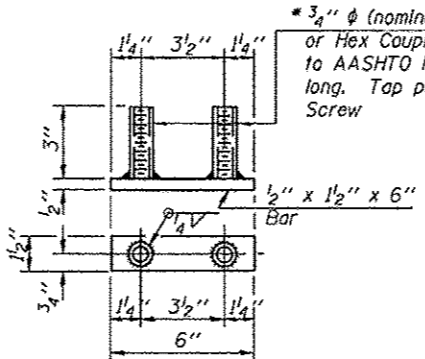

**BOTTOM ANCHOR DEVICE**

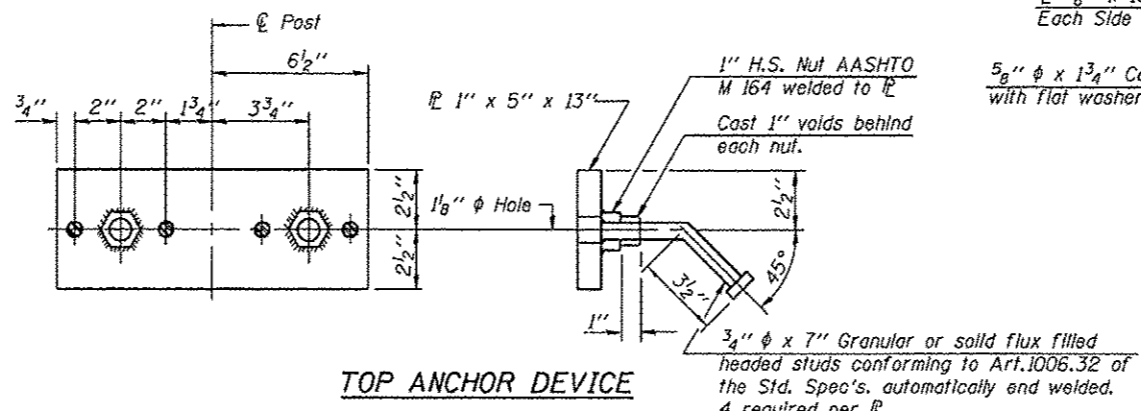

**TOP ANCHOR DEVICE**

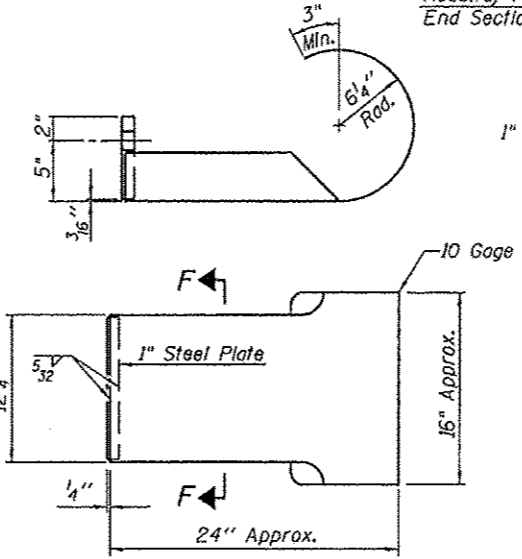

**CURLED END SECTION DETAILS  
(2 Required)**

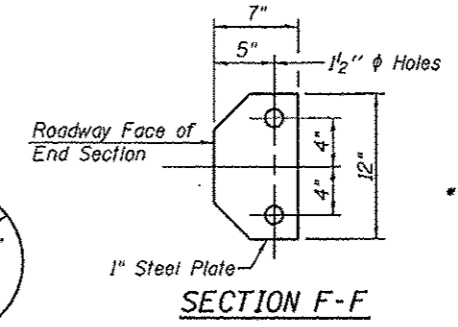

**SECTION F-F**

1 1/8 inch diameter holes for 1 inch x 4 inch round head bolts. Provide 2 flat washers & locknuts for guard rail connection or end section connection.

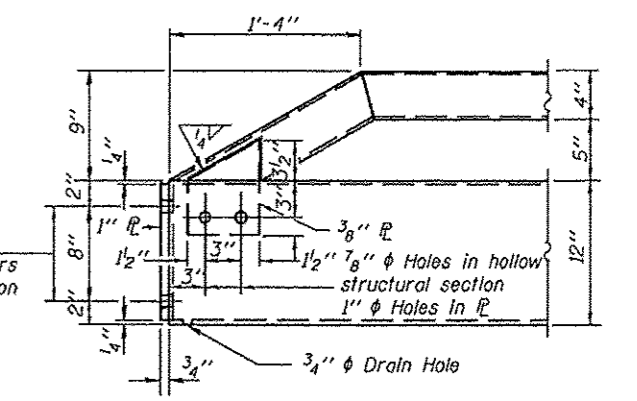

**END OF RAIL DETAILS**

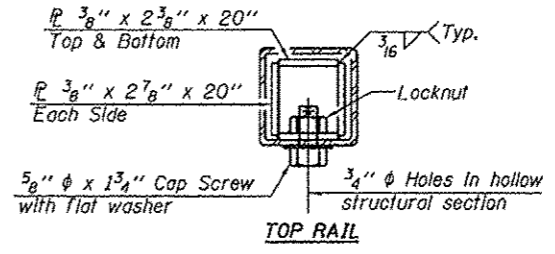

**TOP RAIL**

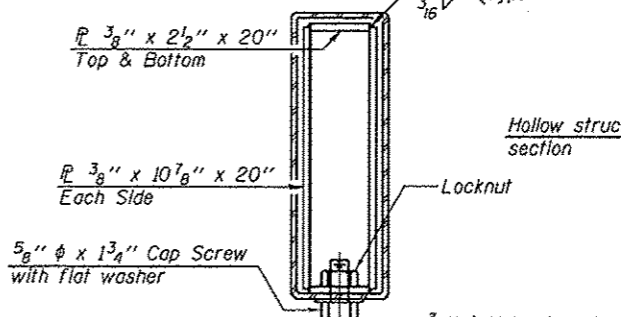

**BOTTOM RAIL  
SECTIONS AT RAIL SPLICE**

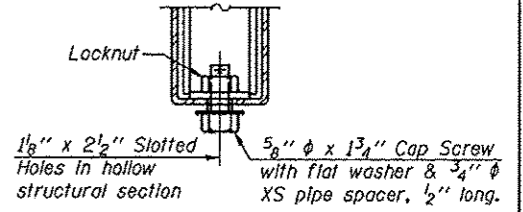

**RAIL SPLICE CONNECTION  
AT EXPANSION JT.**

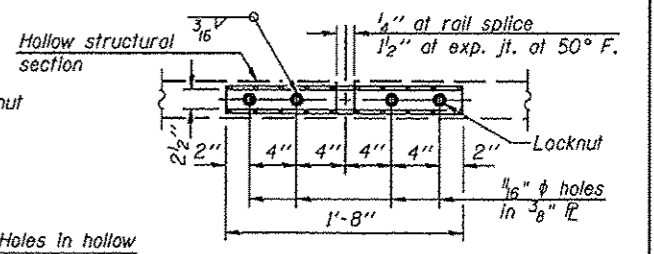

**PLAN-BOTT. SPLICE R  
TYPICAL**

**BILL OF MATERIAL**

| Item                    | Unit | Quantity |
|-------------------------|------|----------|
| Steel Railing, Type T-1 | Foot | 70       |

See sheet 5 of 6 for Rail Post Spacing.



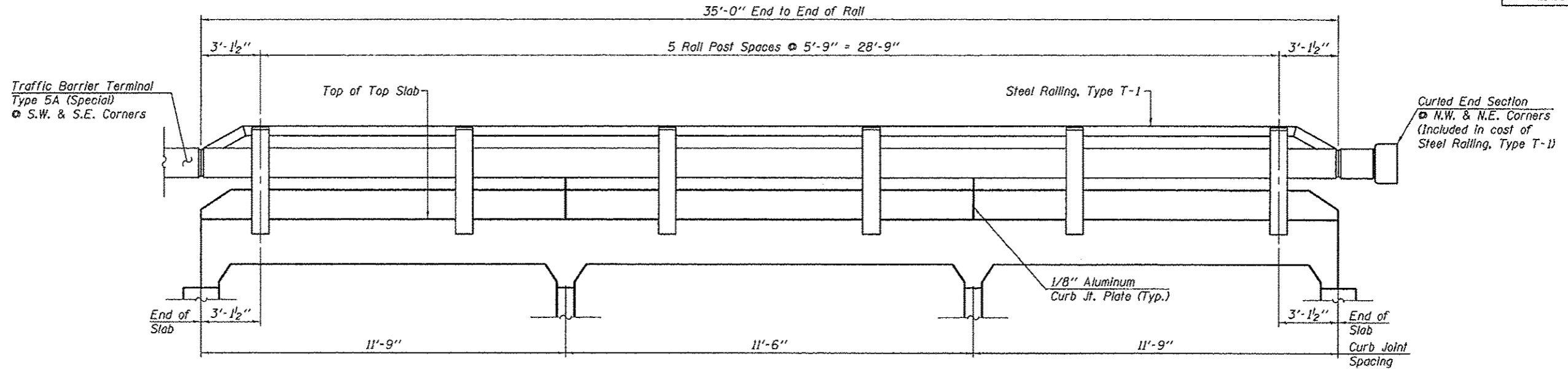

**ELEVATION**  
(Looking West)

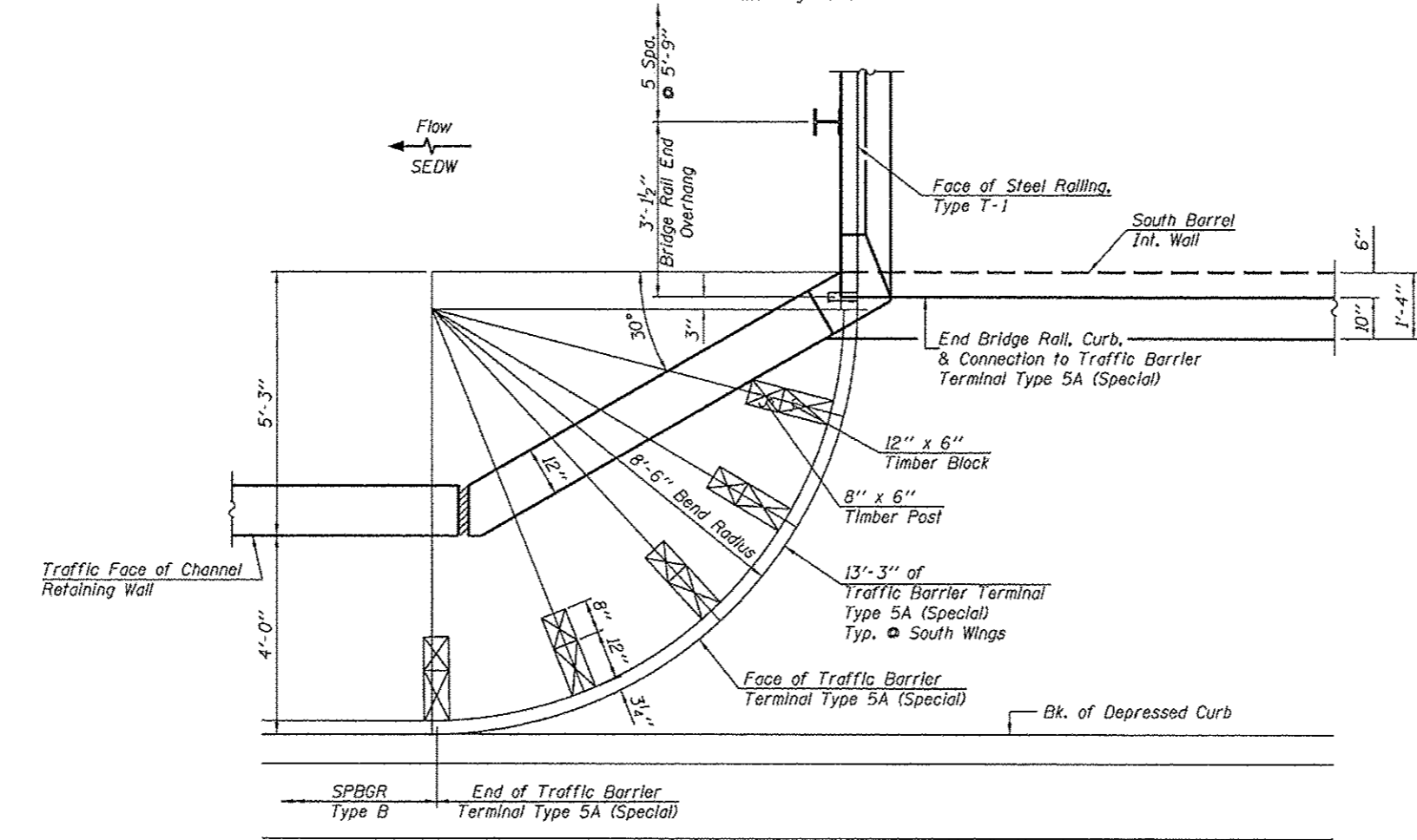

**SOUTH WING AND RAIL LAYOUT PLAN**  
(S.W. Wing Shown)

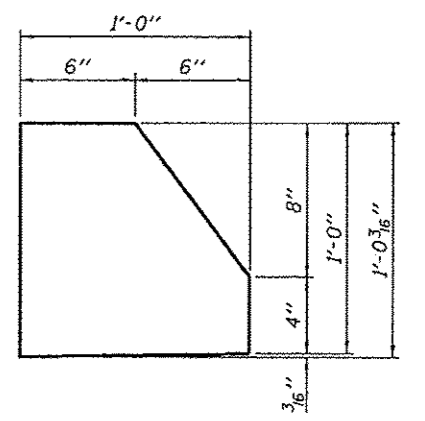

**CURB JOINT PLATE**  
(4 Required)

Note: 1/8" Aluminum Sheet ASTM B 209 alloy 3003-H14, coated to minimize reaction with wet concrete. Cost included with Concrete Box Culverts.

Notes:  
 Approach slab shall be paid for as Concrete Superstructure.  
 Approach footing concrete shall be paid for as Concrete Structures.  
 Reinforcement shall be paid for as Reinforcement Bars, Epoxy Coated.  
 For  $v_3(E)$  bar details, see sheet 3 of 6.  
 The approach footing maximum applied service bearing pressure ( $Q_{max}$ ) = 2.0 ksf.  
 Cost of excavation for approach footing included with Concrete Structures.

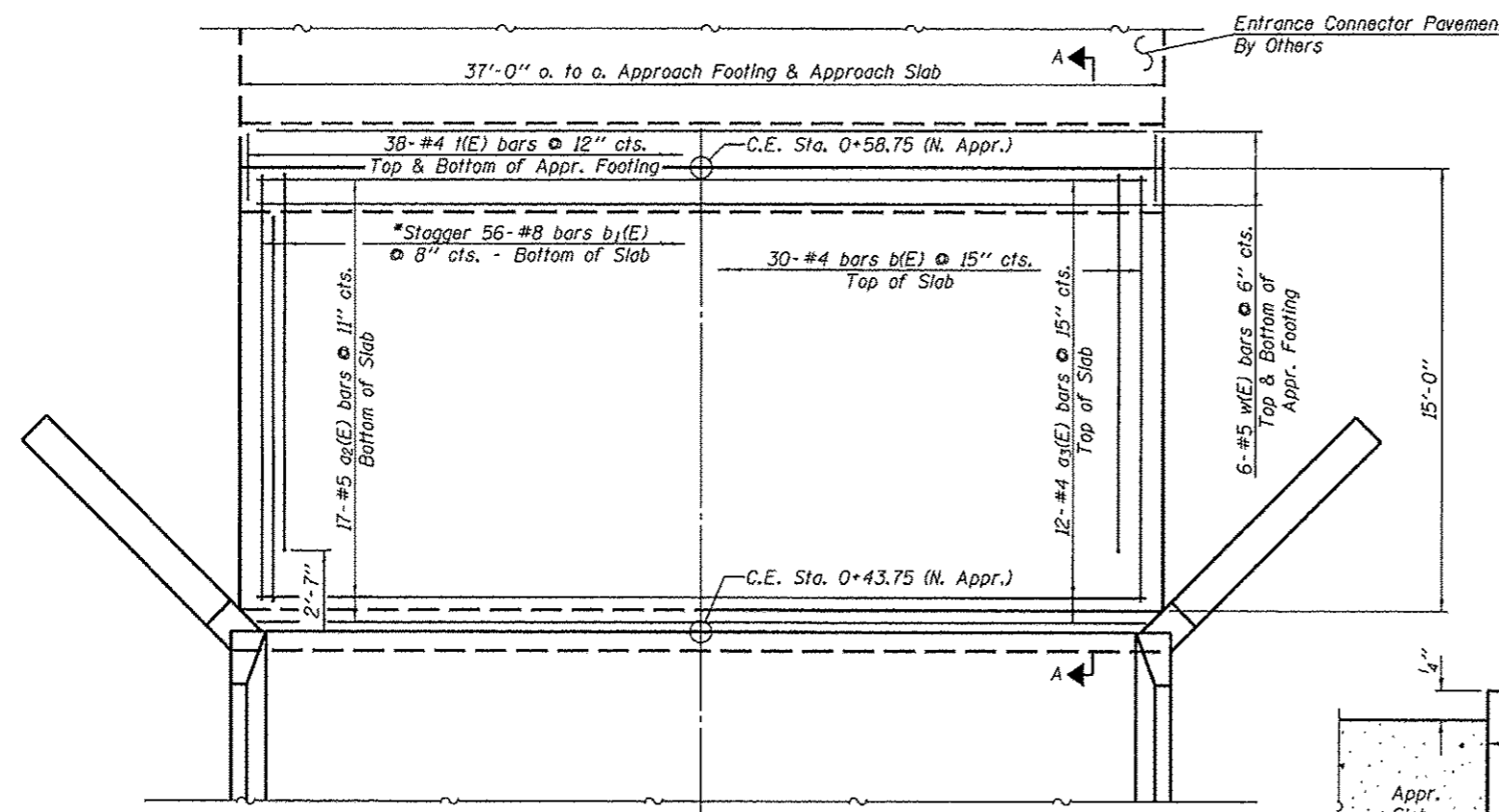

**MIN. BAR LAPS**  
 #4 bar = 2'-1"  
 #5 bar = 2'-7"

\* Tilt  $b_1(E)$  bars as required to maintain clearance.  
 \*\* Cut to fit.

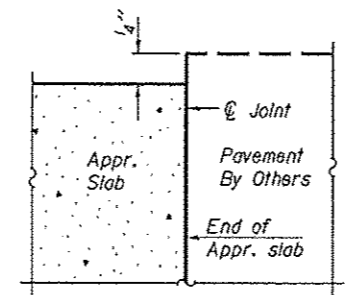

**FLEXIBLE PAVEMENT  
 DETAIL A**

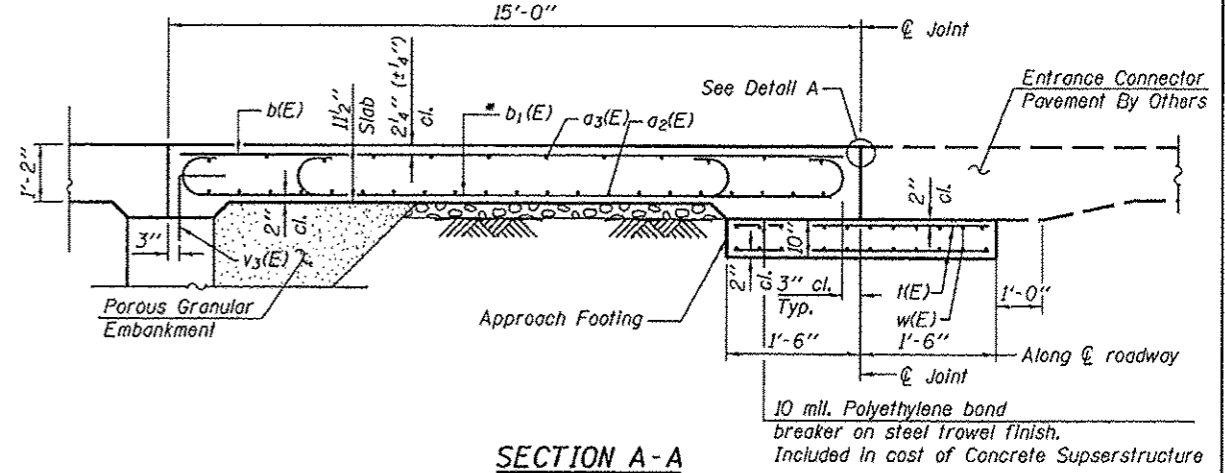

**SECTION A-A**

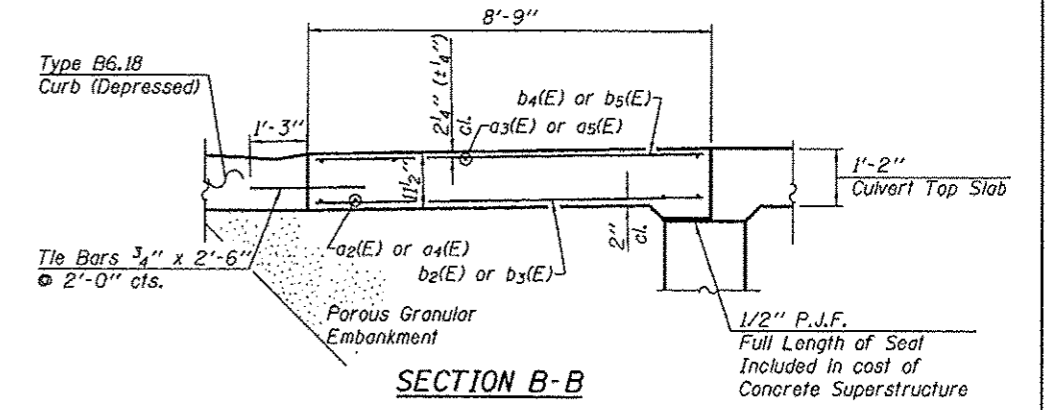

**SECTION B-B**

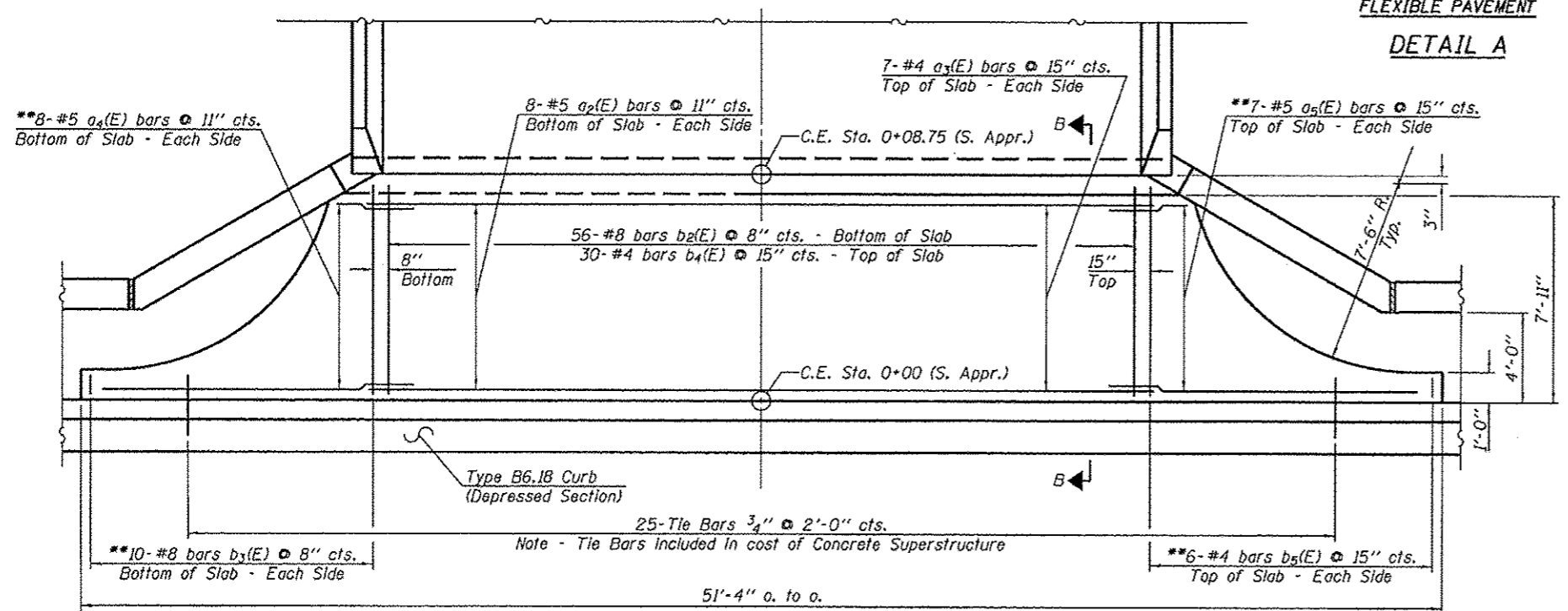

**PLAN**

Note - Tie Bars Included in cost of Concrete Superstructure

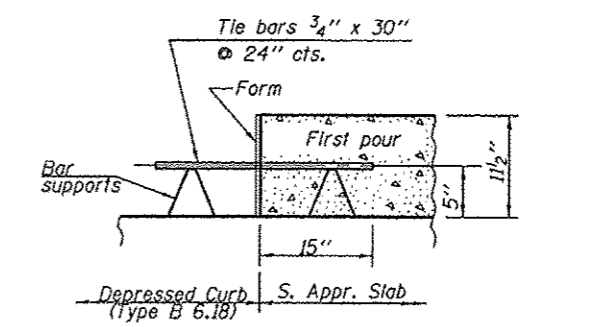

**LONGITUDINAL  
 CONSTRUCTION JOINT  
 (TIE BAR FORMED IN PLACE)**

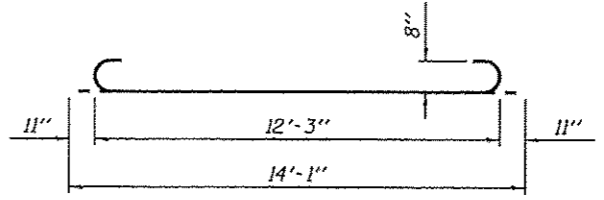

**BAR  $b_1(E)$**

**TWO APPROACHES  
 BILL OF MATERIAL**

| Bar                              | No. | Size | Length  | Shape |
|----------------------------------|-----|------|---------|-------|
| $a_2(E)$                         | 25  | #5   | 36'-8"  | —     |
| $a_3(E)$                         | 19  | #4   | 36'-8"  | —     |
| $a_4(E)$                         | 16  | #5   | 9'-9"   | —     |
| $a_5(E)$                         | 14  | #4   | 9'-3"   | —     |
| $b(E)$                           | 30  | #4   | 14'-8"  | —     |
| $b_1(E)$                         | 56  | #8   | 14'-1"  | —     |
| $b_2(E)$                         | 56  | #8   | 8'-5"   | —     |
| $b_3(E)$                         | 20  | #8   | 8'-0"   | —     |
| $b_4(E)$                         | 30  | #4   | 8'-5"   | —     |
| $b_5(E)$                         | 12  | #4   | 8'-0"   | —     |
| $l(E)$                           | 76  | #4   | 2'-8"   | —     |
| $w(E)$                           | 12  | #5   | 36'-9"  | —     |
| Protective Coat                  |     |      | Sq. Yd. | 101   |
| Concrete Superstructure          |     |      | Cu. Yd. | 33.3  |
| Concrete Structures              |     |      | Cu. Yd. | 3.4   |
| Reinforcement Bars, Epoxy Coated |     |      | Pound   | 6580  |
| Bridge Deck Grooving             |     |      | Sq. Yd. | 96    |

Bench Marks: BM 304 is a "Chiseled square on the NW corner of the NW wing wall approx. Sta. 162+12, 55' Lt. - Elev. 742.23

|             |                |                    |
|-------------|----------------|--------------------|
| F.A.P. RTE. | SECTION        | COUNTY             |
| 525         | 01-00509-00-RP | WINNEBAGO          |
| ILLINOIS    |                | CONTRACT NO. 85812 |

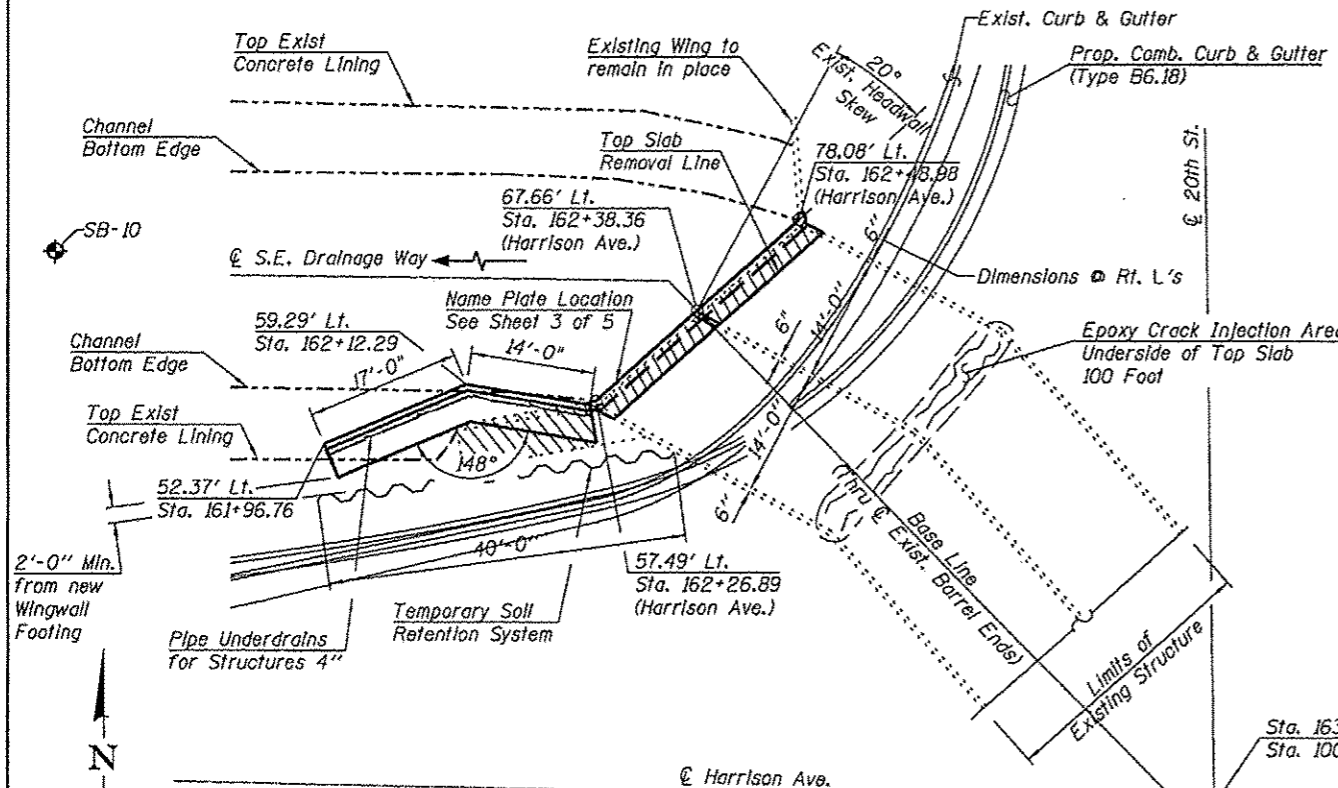

Existing Structure: S.N. 101-5006 is a R.C. Double Barrel Box Culvert (2 @ 14'-0" x 3'-6") originally constructed in 1956, as Section 86 Project S-703(2), and extended to its present (kinked) alignment in 1983 to its 212'-2" o.-o. length. The original barrel segment is built @ 42° Rt. Skew to Harrison Ave.. Existing structure is to be extended at the S.E. end and rehabilitated at the N.W. end for Intersection Improvements and barrel alignment with S.E.O.W.

**INDEX OF SHEETS**

1. General Plan Culvert Extension
2. Culvert Downstream Plan Details
3. Culvert Downstream Details
4. Culvert Upstream Plan & Elevation
5. Culvert Upstream Details

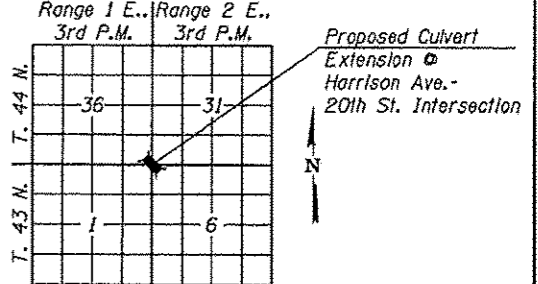

**GENERAL NOTES**

Reinforcement bars shall conform to the requirements of ASTM A706 Grade 60.

Reinforcement bars designated (E) shall be epoxy coated.

A Precast Concrete Culvert alternate will not be allowed.

Exposed portions of wingwalls & curbs shall receive a rubbed finish in accordance with Article 503.15(b) of Standard Specifications. Cost shall be included in cost for Concrete Box Culverts.

Plan dimensions and details relative to existing plans are subject to nominal construction variations. The Contractor shall field verify existing dimensions and details affecting new construction and make necessary approved adjustments prior to construction or ordering of materials. Such variations shall not be cause for additional compensation for a change in scope of work, however, the Contractor will be paid for the quantity actually furnished at the unit price bid for the work.

Structure Excavation will not be measured for payment but shall be included in the unit price bid for "Concrete Box Culverts" or "Concrete Removal".

**WATERWAY INFORMATION**

|                           |           |              |
|---------------------------|-----------|--------------|
| Drainage Area             | ( ** Yr.) | 2.46 Sq. Mi. |
| Existing Opening (Bridge) | ( ** Yr.) | 98 Sq. Ft.   |
| Required Opening          | ( ** Yr.) | 98 Sq. Ft.   |
| Proposed Opening (Bridge) | ( ** Yr.) | 98 Sq. Ft.   |
| Design Discharge          | ( ** Yr.) | 1100 C.F.S.  |
| Existing Created Head     | ( ** Yr.) | 1.64 Ft.     |
| Proposed Created Head     | ( ** Yr.) | 1.74 Ft.     |

\*\*Existing Channel Capacity

**HIGHWAY CLASSIFICATION**

Harrison Avenue FA Route 525  
 Functional Class: Regional Arterial  
 ADT: 12850 (2015); 16150 (2035)  
 ADTT: 951 (6% - 2035)  
 DHV: 1615  
 Design Speed: 45 m.p.h.  
 Posted Speed: 45 m.p.h.

**DESIGN STRESSES**

**FIELD UNITS (NEW CONST.)**  
 $f'_c = 3,500$  psi  
 $f_y = 60,000$  psi (Reinforcement)  
**EXISTING CONST. (1956 PLANS)**  
 $f_s = 20,000$  psi  
 $f_c = 1,200$  psi  
 $n = 10$

**DESIGN SPECIFICATIONS**

2002 AASHTO Standard Specifications - 17th Edition

**LOADING HS-20**

Allow 50#/sq. ft. for future wearing surface (New Extensions).

**PROPOSED PROFILE GRADE - HARRISON AVE.**

(Along P.G. Line @ 8'-0" Offsets Lt. & Rt. @ Harrison Ave.)

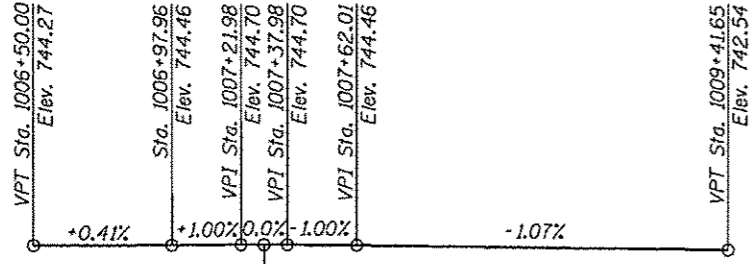

**PROPOSED PROFILE GRADE - 20TH STREET**

(Along Proposed @ 20th Street)

"I certify that to the best of my knowledge, information and belief, this bridge design is structurally adequate for the design loading shown on the plans. The design is an economical one for the style of structure and complies with requirements of the current 'AASHTO Standard Specifications for Highway Bridges'".

*John A. Morris* 6/11/15  
 ILLINOIS STRUCTURAL NO. 4277 (Expires 11/30/16)

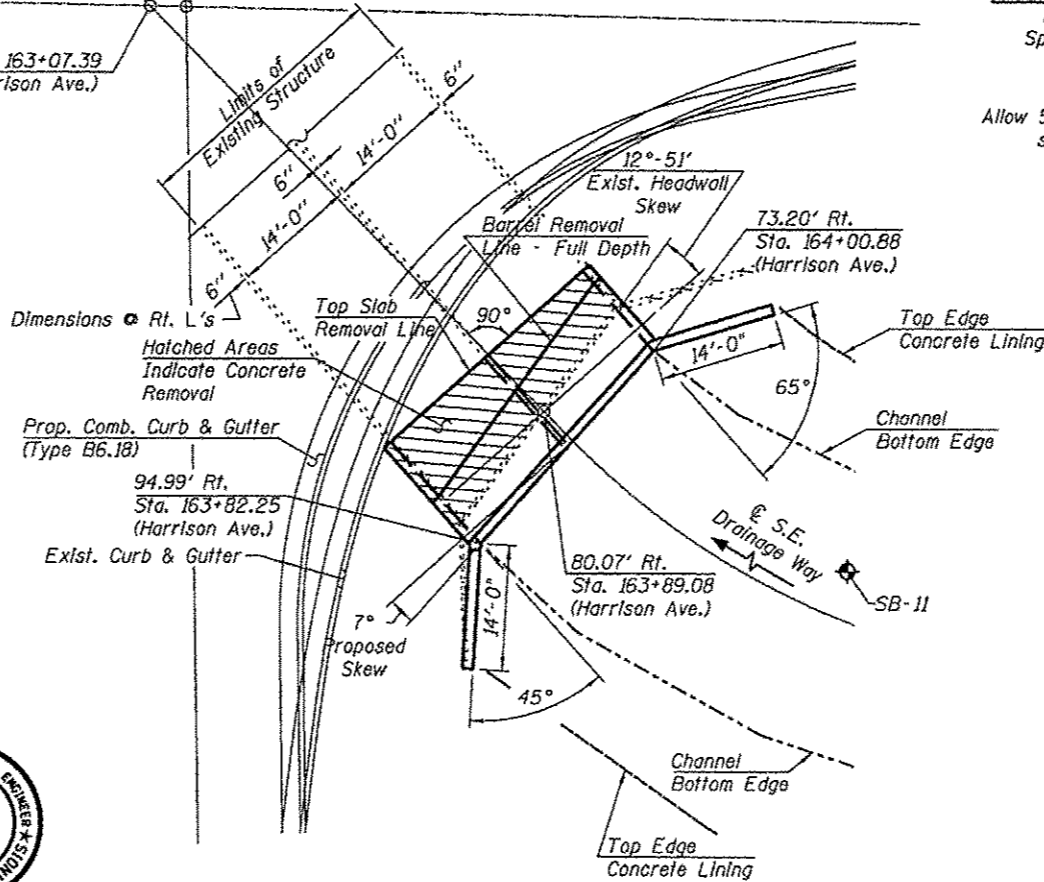

**TOTAL BILL OF MATERIAL**

| ITEM  | UNIT    | TOTAL  |
|---|---------|--------|
| Concrete Removal  | Cu. Yd. | 35.2   |
| Concrete Box Culverts                                       | Cu. Yd. | 44.3   |
| Reinforcement Bars, Epoxy Coated                            | Pound   | 15,050 |
| Protective Coat   | Sq. Yd. | 13     |
| Geocomposite Wall Drain                                     | Sq. Yd. | 27     |
| Pipe Underdrains for Structures 4"                          | Foot    | 31     |
| Rock Fill   | Ton     | 84     |
| Removal and Disposal of Unsuitable Materials for Structures | Cu. Yd. | 51     |
| Expansion Bolts 3/4 Inch x 15 Inch                          | Each    | 77     |
| Name Plates   | Each    | 1      |
| Temporary Soil Retention System                             | Sq. Ft. | 333    |
| Porous Granular Embankment                                  | Cu. Yd. | 136    |
| Epoxy Crack Injection                                       | Foot    | 100    |
| Structure Excavation  | Cu. Yd. | 242    |

**GENERAL PLAN**  
**HARRISON AVE. - IL RTE. 251 / 20TH ST.**  
**OVER SOUTHEAST DRAINAGE WAY**  
**SECTION 01-00509-00-RP**  
**CITY OF ROCKFORD, ILLINOIS**  
**WINNEBAGO COUNTY**  
**STA. 163+07.39 (HARRISON AVE.)**  
**S.N. 101-5006**

| REVISIONS |  |
|-----------|--|
|           |  |
|           |  |
|           |  |
|           |  |

Note: New Headwall Concrete to be poured to top elevation of existing exterior wall.

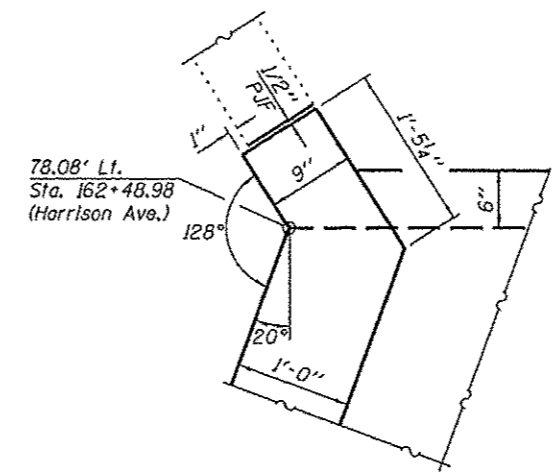

**DOWNSTREAM NORTHEAST CORNER DETAIL**

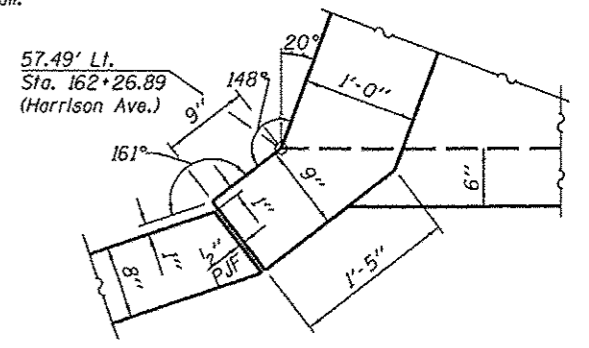

**DOWNSTREAM SOUTHWEST CORNER DETAIL**

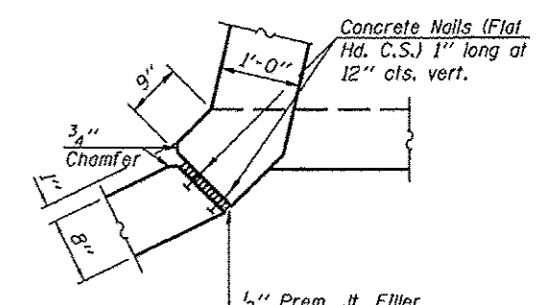

**CORNER DETAIL FOR PJF**

Expansion bolts shall be 3/4" hooked bolts. Hooked bolts shall extend a minimum of 9" into new concrete.

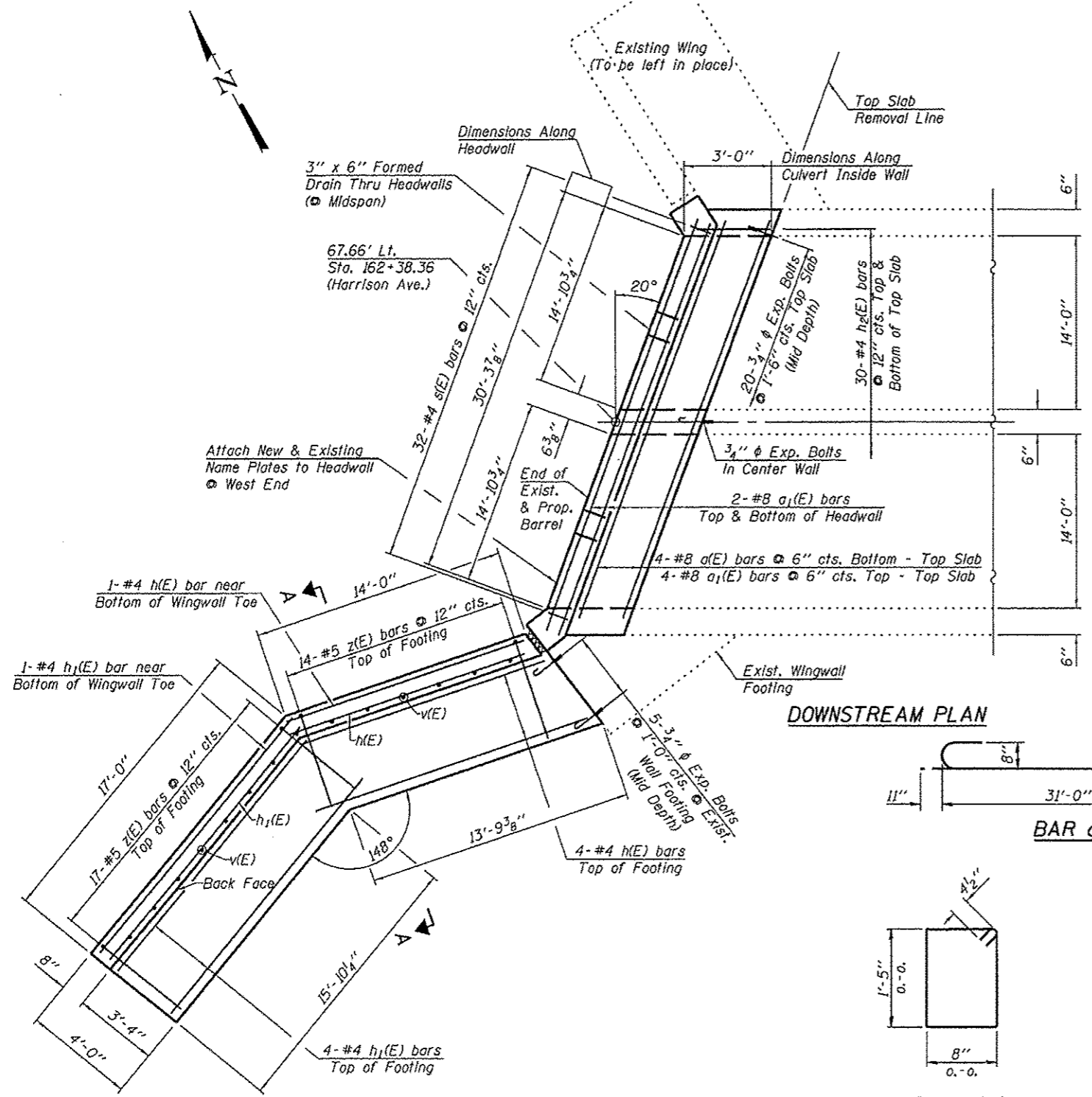

**DOWNSTREAM PLAN**

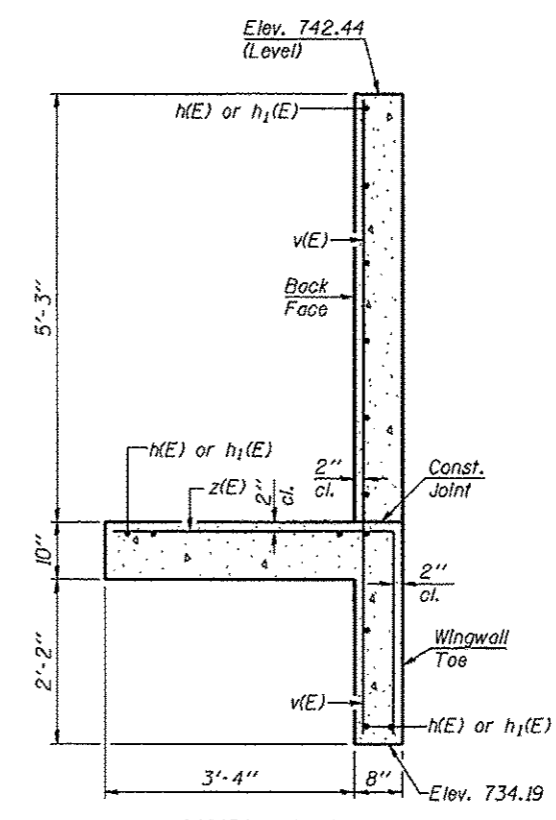
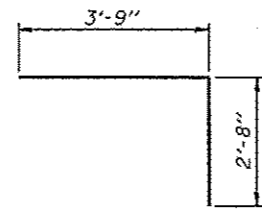
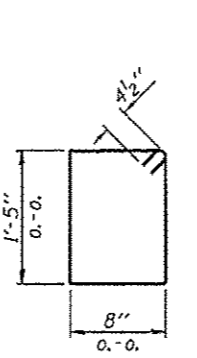
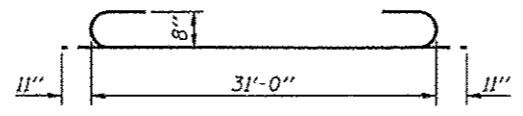

**SECTION A-A**

\*v(E) bars shall not be placed more than 2" cl. from back face of wingwall.

**BILL OF MATERIAL**  
(Downstream End)

| Bar   | No. | Size | Length  | Shape |
|---|-----|------|---------|-------|
| a(E)  | 4   | #8   | 32'-10" |       |
| a1(E)   | 8   | #8   | 31'-0"  |       |
| h(E)  | 14  | #4   | 13'-9"  |       |
| h1(E)   | 14  | #4   | 16'-9"  |       |
| h2(E)   | 60  | #4   | 2'-9"   |       |
| v(E)  | 31  | #5   | 8'-0"   |       |
| v1(E)   | 4   | #5   | 4'-3"   |       |
| s(E)  | 32  | #4   | 4'-11"  |       |
| z(E)  | 31  | #5   | 6'-5"   |       |
| Structure Excavation                                      |     |      | Cu. Yd. | 44    |
| Removal & Disposal of Unsuitable Materials for Structures |     |      | Cu. Yd. | 23    |
| Rock Fill   |     |      | Ton     | 36    |
| Concrete Box Culverts                                     |     |      | Cu. Yd. | 13.9  |
| Reinforcement Bars, Epoxy Coated                          |     |      | Pound   | 2,000 |
| Expansion Bolts 3/4 inch x 15 inch                        |     |      | Each    | 28    |
| Geocomposite Wall Drain                                   |     |      | Sq. Yd. | 13    |
| Porous Granular Embankment                                |     |      | Cu. Yd. | 46    |
| Concrete Removal  |     |      | Cu. Yd. | 8.8   |
| Protective Coat   |     |      | Sq. Yd. | 6     |
| Temporary Soil Retention System                           |     |      | Sq. Ft. | 333   |