

STATE OF ILLINOIS
DEPARTMENT OF TRANSPORTATION

F.A. RTE.	SECTION	COUNTY	TOTAL SHEETS	SHEET NO.
VAR	2020-245-1	VARIOUS	21	1
		ILLINOIS	CONTRACT NO. 62N15	

FOR INDEX OF SHEETS, SEE SHEET NO. 2

PROPOSED HIGHWAY PLANS

ROUTE: VARIOUS EXPRESSWAYS AND ARTERIAL
HIGHWAYS – DISTRICT ONE

SECTION: 2020-245-1

FENCE REPAIR

COUNTY: VARIOUS

C-91-052-21

D-91-052-21



THIS SECTION IS LOCATED ALONG VARIOUS ROUTES WITHIN THE DISTRICT ONE COUNTIES OF Mc HENRY, LAKE, KANE, DU PAGE, COOK AND WILL.

SEE LOCATION MAPS
SHEETS 4 THRU 12

C.U.A.N.
CHICAGO UTILITY ALERT NETWORK
1-312-744-7000

J.U.L.I.E.
JOINT UTILITY LOCATION INFORMATION FOR EXCAVATION
1-800-892-0123
OR 811

PROJECT MANAGER: J. ALAIN MIDY (847) 221-3056

CONTRACT NO. 62N15

STATE OF ILLINOIS
DEPARTMENT OF TRANSPORTATION

SUBMITTED October 10, 2020
Anthony J. Quigley / **CB**
 REGIONAL ENGINEER
 December 4, 2020
See E.A. Elk
 ENGINEER OF DESIGN AND ENVIRONMENT
 December 4, 2020
James J. ...
 DIRECTOR OF HIGHWAYS PROJECT IMPLEMENTATION '13

PRINTED BY THE AUTHORITY
OF THE STATE OF ILLINOIS

SUMMARY OF QUANTITIES			CONSTRUCTION TYPE CODE 0021					
CODE NO	ITEM	UNIT	TOTAL QUANTITIES URBAN	100% STATE 0021	100% MCHD 0021			
66400505	CHAIN LINK FENCE, 8'	FOOT	174	139	35			
66500105	WOVEN WIRE FENCE, 4'	FOOT	2646	2117	529			
X6640100	FENCE RAIL REMOVAL	FOOT	1612	1290	322			
X6640300	CHAIN LINK FENCE REMOVAL	FOOT	41	33	8			
X6640309	CHAIN LINK GATES (SPECIAL)	SO FT	609	487	122			
X6640590	CHAIN LINK FENCE POST SLEEVE REPAIR	EACH	35	28	7			
Z0009600	CHAIN LINK FABRIC, SPECIAL, 5'-0"	FOOT	18	14	4			
Z0009700	CHAIN LINK FABRIC, SPECIAL, 6'-0"	FOOT	1344	1075	269			
Z0009800	CHAIN LINK FABRIC, SPECIAL, 7'-0"	FOOT	8	6	2			
Z0009810	CHAIN LINK FABRIC, SPECIAL, 8'-0"	FOOT	53	42	11			
Z0009900	CHAIN LINK FABRIC, TYPE 1, 4'-0"	FOOT	14608	11686	2922			
Z0010300	CHAIN LINK FABRIC, TYPE 3, SPECIAL	FOOT	348	278	70			
Z0020210	PULL POST ARRANGEMENT	EACH	2	1	1			
Z0033200	LINE POST, TYPE 1	EACH	627	502	125			
Z0033305	LINE POST, TYPE 3 SPECIAL	EACH	18	14	4			
Z0042500	POST, SPECIAL	EACH	69	55	14			

SUMMARY OF QUANTITIES			CONSTRUCTION TYPE CODE 0021					
CODE NO	ITEM	UNIT	TOTAL QUANTITIES URBAN	100% STATE 0021	100% MCHD 0021			
Z0042505	POST REMOVAL AND REPLACEMENT	EACH	5	4	1			
Z0074000	TERMINAL POST, TYPE 1	EACH	35	28	7			
Z0074010	TERMINAL POST, TYPE 3 SPECIAL	EACH	5	4	1			

FILE NAME =	USER NAME = mdayja	DESIGNED -	REVISED -
p:\planroom\dtd\illinois\gov\PI\DOT\Documents\DOT	Offices\District\Projects\DI44816\CAD\ata\Des\gn\DI44816	DRAWN -	REVISED -
	PLOT SCALE = 100.0000' / 1in.	CHECKED -	REVISED -
	PLOT DATE = 10/21/2020	DATE -	REVISED -

**STATE OF ILLINOIS
DEPARTMENT OF TRANSPORTATION**

SUMMARY OF QUANTITIES			
SCALE:	SHEET NO.	OF SHEETS	STA. TO STA.

F.A. RTE.	SECTION	COUNTY	TOTAL SHEETS	SHEET NO.
VAR	2020-245-1	VARIOUS	21	3
			CONTRACT NO. 62N15	
FED. ROAD DIST. NO. 1 ILLINOIS FED. AID PROJECT				

REV-SEP



DISTRICT NO. 1 MAINTENANCE DESIGNATIONS

- VARIOUS COLORS STATE HIGHWAYS & EXPRESSWAYS
- TOLLWAY
- █ CITY MAINTENANCE AGREEMENTS
- - - - FUTURE HIGHWAYS
- VARIOUS AGENCIES HIGHWAYS

FILE NAME =	USER NAME = midyja	DESIGNED -	REVISED -
p:\planroom\dot.illinois.gov\PIDOT\Documents\DOT Offices\District 1\Projects\0144815\Drawings\Design\0144816-sht-plan.dgn		DRAWN -	REVISED -
Default		CHECKED -	REVISED -
	PLOT DATE = 10/21/2020	DATE -	REVISED -

**STATE OF ILLINOIS
DEPARTMENT OF TRANSPORTATION**

**FENCE REPAIR LOCATION MAP - COOK COUNTY
SOUTH OF IL RTE 38**

SCALE: SHEET OF SHEETS STA. TO STA.

F.A. RTE.	SECTION	COUNTY	TOTAL SHEETS	SHEET NO.
VAR	2020-245-1	VARIOUS	21	4
			CONTRACT NO. 62N15	
ILLINOIS FED. AID PROJECT				

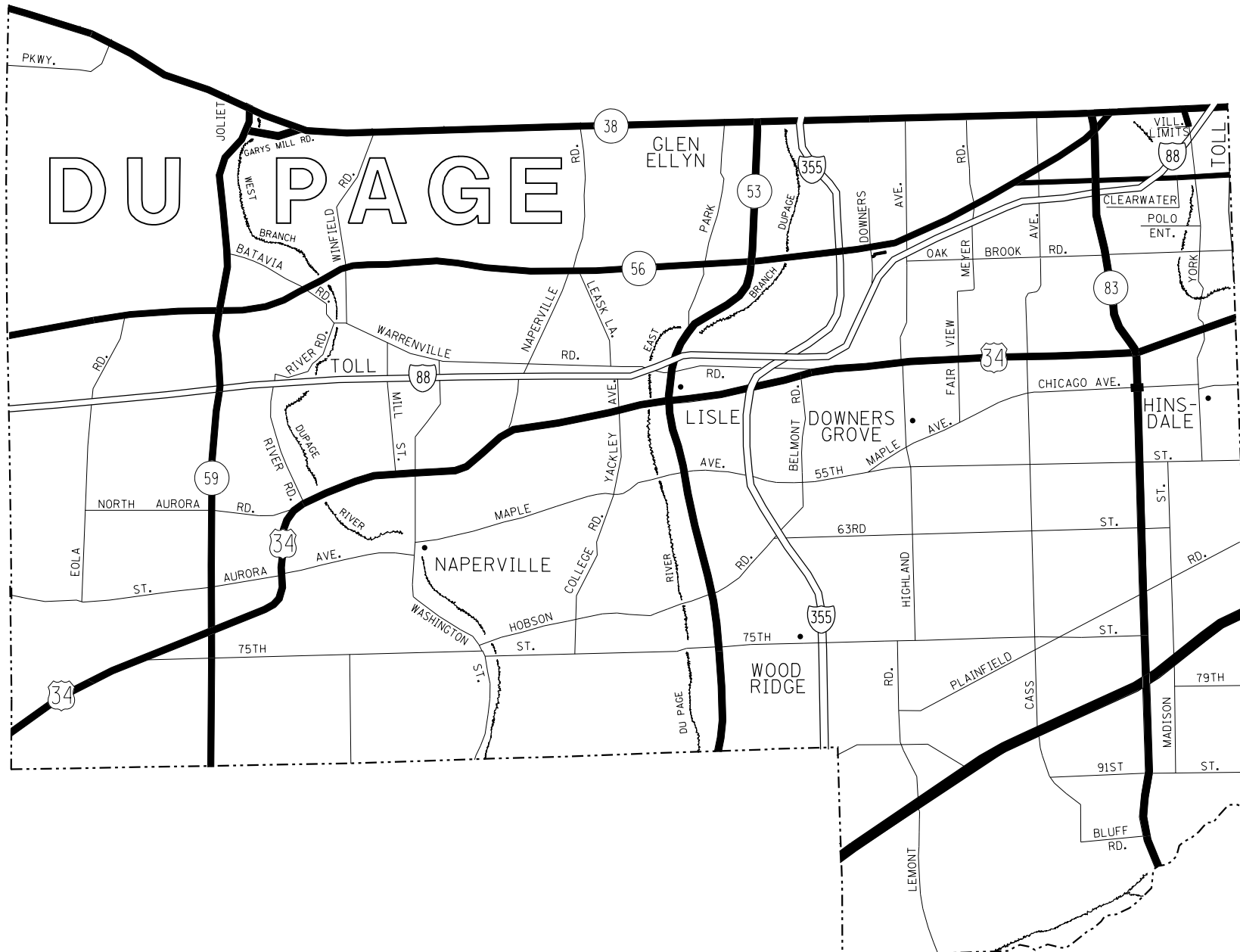

DISTRICT NO. 1
MAINTENANCE DESIGNATIONS

- VARIOUS COLORS STATE HIGHWAYS & EXPRESSWAYS
- TOLLWAY
- CITY MAINTENANCE AGREEMENTS
- FUTURE HIGHWAYS
- VARIOUS AGENCIES HIGHWAYS

FILE NAME =	USER NAME = midyja	DESIGNED -	REVISED -
pw:\planroom.dot.illinois.gov\PIDOT\Documents\IDOT Offices\District 1\Projects\0144816\Design\0144816-sht-plan.dgn		DRAWN -	REVISED -
Default	PLOT SCALE = 100.0000' / in.	CHECKED -	REVISED -
	PLOT DATE = 10/21/2020	DATE -	REVISED -

**STATE OF ILLINOIS
DEPARTMENT OF TRANSPORTATION**

**FENCE REPAIR LOCATION MAP - DuPAGE COUNTY
SOUTH OF IL RTE 38**

SCALE: SHEET OF SHEETS STA. TO STA.

F.A. RTE.	SECTION	COUNTY	TOTAL SHEETS	SHEET NO.
VAR	2020-245-1	VARIOUS	21	5
CONTRACT NO. 62N15			ILLINOIS FED. AID PROJECT	

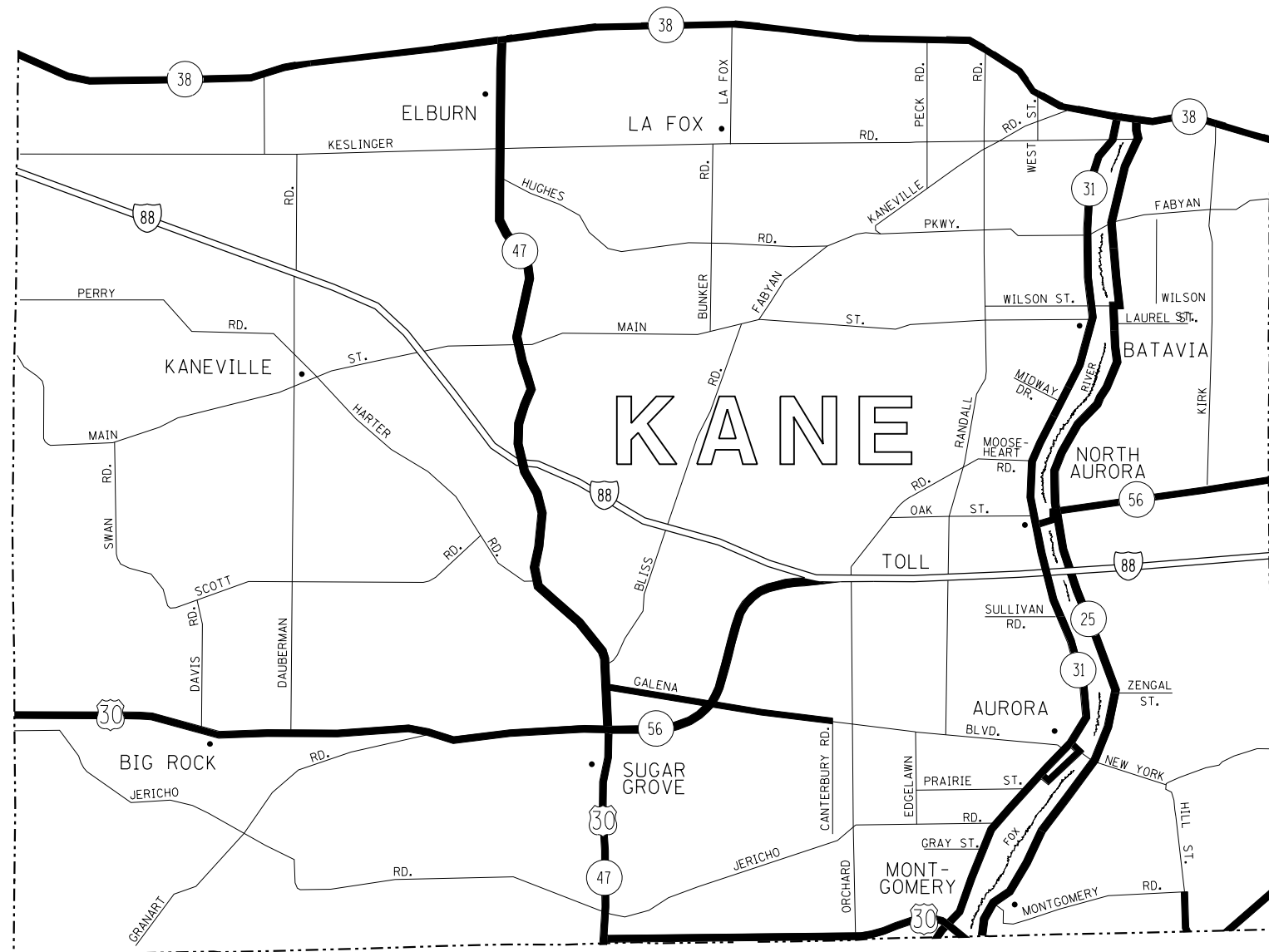

DISTRICT NO. 1
MAINTENANCE DESIGNATIONS

- VARIOUS COLORS STATE HIGHWAYS & EXPRESSWAYS
- ==== TOLLWAY
- ==== CITY MAINTENANCE AGREEMENTS
- FUTURE HIGHWAYS
- VARIOUS AGENCIES HIGHWAYS

FILE NAME =	USER NAME = midyja	DESIGNED -	REVISED -
p:\planroom\dot.illinois.gov\PIDOT\Documents\IDOT Offices\District 1\Projects\0144815\DRAWING\Design\0144816-sht-plan.dgn		DRAWN -	REVISED -
Default	PLOT SCALE = 100.0000' / in.	CHECKED -	REVISED -
	PLOT DATE = 10/21/2020	DATE -	REVISED -

STATE OF ILLINOIS
DEPARTMENT OF TRANSPORTATION

FENCE REPAIR LOCATION MAP - KANE COUNTY
SOUTH OF IL RTE 38

SCALE: SHEET OF SHEETS STA. TO STA.

F.A. RTE.	SECTION	COUNTY	TOTAL SHEETS	SHEET NO.
VAR	2020-245-1	VARIOUS	21	6
			CONTRACT NO. 62N15	
ILLINOIS FED. AID PROJECT				

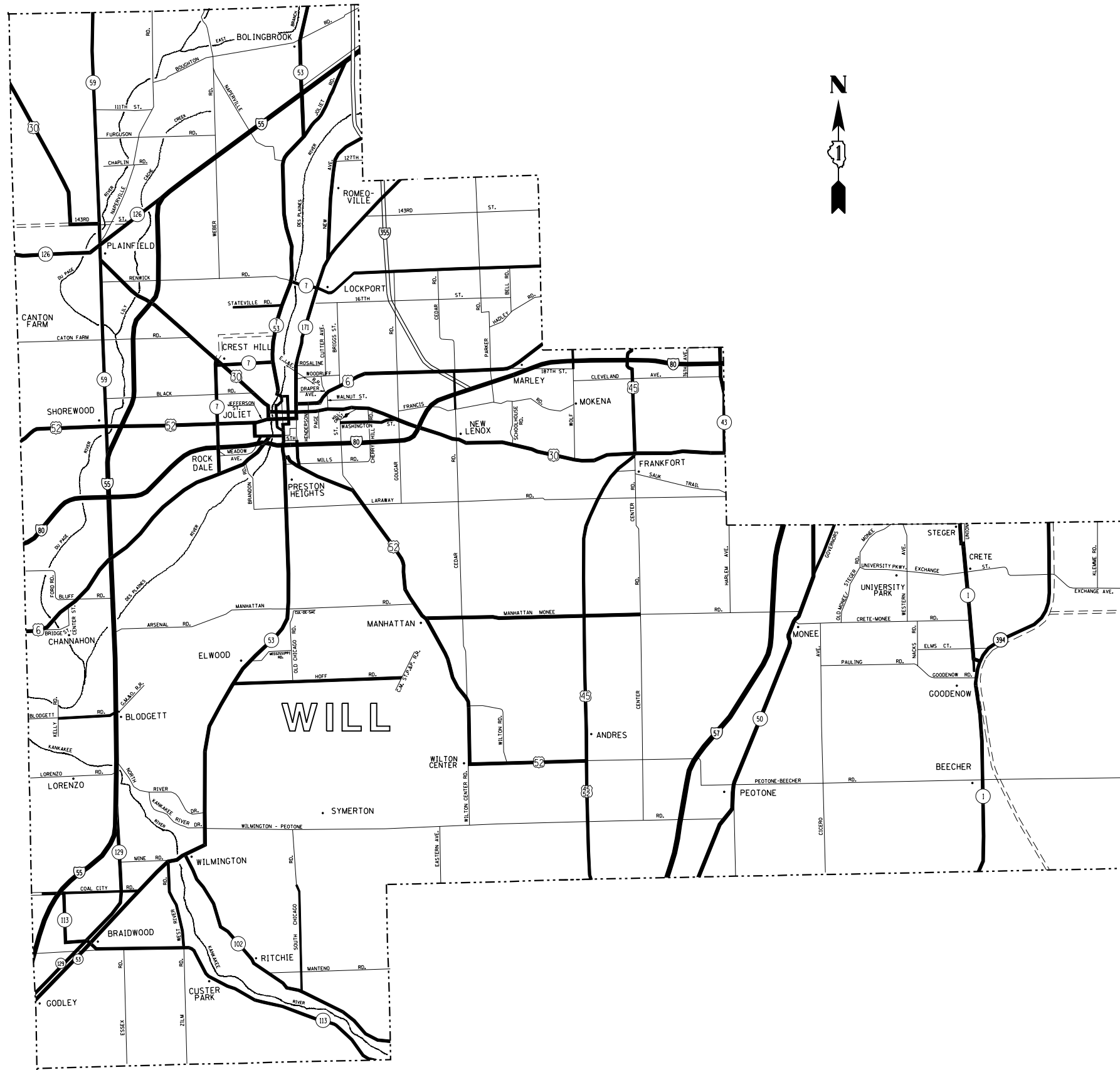

DISTRICT NO. 1 MAINTENANCE DESIGNATIONS

- VARIOUS COLORS STATE HIGHWAYS & EXPRESSWAYS
- TOLLWAY
- CITY MAINTENANCE AGREEMENTS
- FUTURE HIGHWAYS
- VARIOUS AGENCIES HIGHWAYS

FILE NAME =	USER NAME = midyja	DESIGNED -	REVISED -
pw\planroom.dot.illinois.gov\PIDOT\Documents\IDOT Offices\District 1\Projects\0144816\Drawn\Design\0144816-sht-plan.dgn		DRAWN	REVISED -
Default	PLOT SCALE = 100.0000' / 1" =	CHECKED -	REVISED -
	PLOT DATE = 10/21/2020	DATE -	REVISED -

**STATE OF ILLINOIS
DEPARTMENT OF TRANSPORTATION**

FENCE REPAIR LOCATION MAP - WILL COUNTY

SCALE: SHEET OF SHEETS STA. TO STA.

F.A. RTE.	SECTION	COUNTY	TOTAL SHEETS	SHEET NO.
VAR	2020-245-1	VARIOUS	21	7
CONTRACT NO. 62N15				
ILLINOIS FED. AID PROJECT				

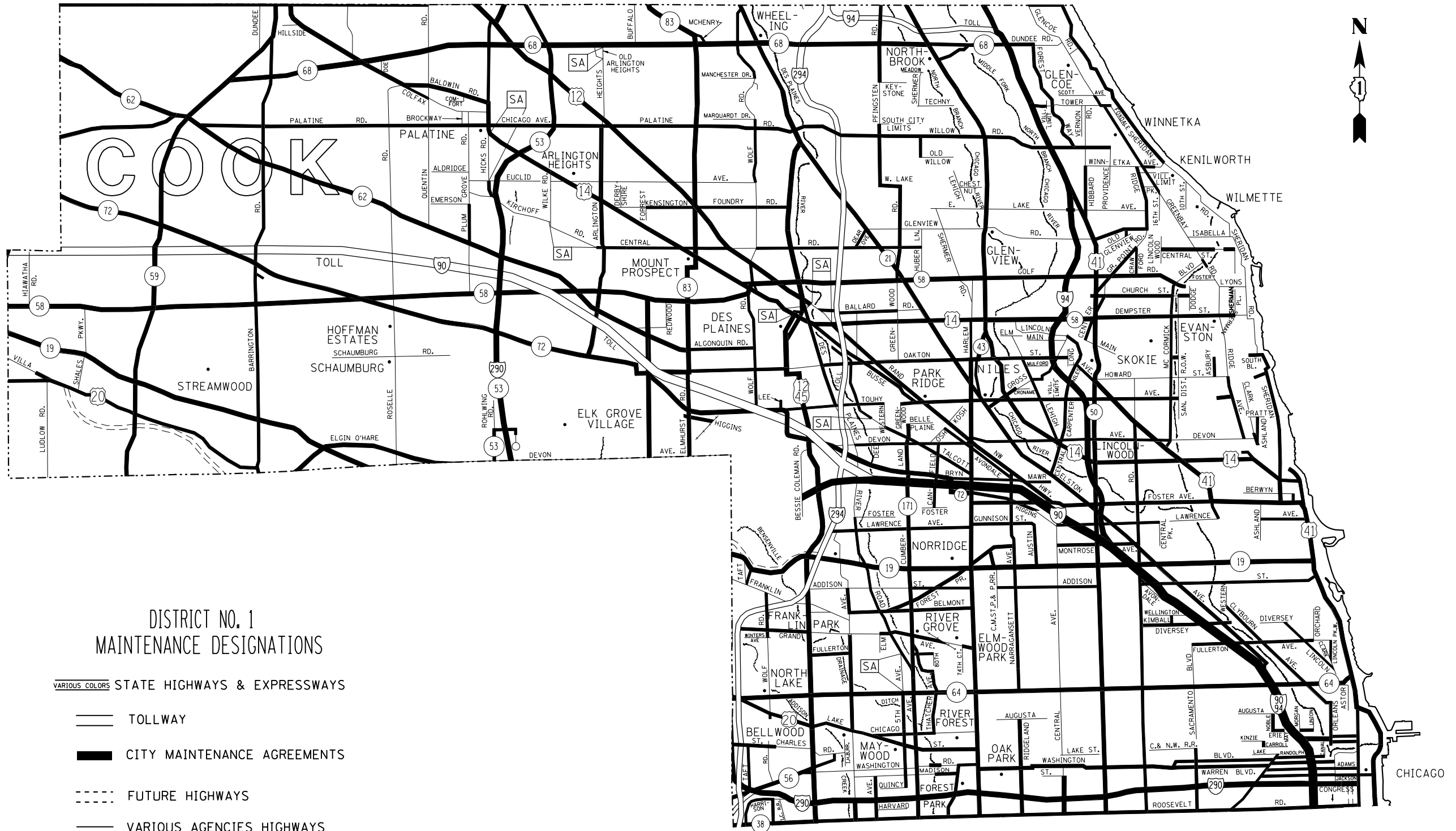

DISTRICT NO. 1
MAINTENANCE DESIGNATIONS

- VARIOUS COLORS STATE HIGHWAYS & EXPRESSWAYS
- TOLLWAY
 - CITY MAINTENANCE AGREEMENTS
 - FUTURE HIGHWAYS
 - VARIOUS AGENCIES HIGHWAYS

FILE NAME =	USER NAME = midyja	DESIGNED -	REVISED -
pw\planroom.dot.illinois.gov\PWIDOT\Documents\DOT Offices\District 1\Projects\0144816\Drawn\Design\0144816-sht-plan.dgn		DRAWN	REVISED -
Default	PLOT SCALE = 100.0000' / in.	CHECKED -	REVISED -
	DATE = 10/21/2020	DATE -	REVISED -

STATE OF ILLINOIS
DEPARTMENT OF TRANSPORTATION

FENCE REPAIR LOCATION MAP - COOK COUNTY
NORTH OF IL RTE 38

SCALE:	SHEET	OF	SHEETS	STA.	TO	STA.
--------	-------	----	--------	------	----	------

F.A. RTE.	SECTION	COUNTY	TOTAL SHEETS	SHEET NO.
VAR	2020-245-1	VARIOUS	21	8
			CONTRACT NO. 62N15	
ILLINOIS FED. AID PROJECT				

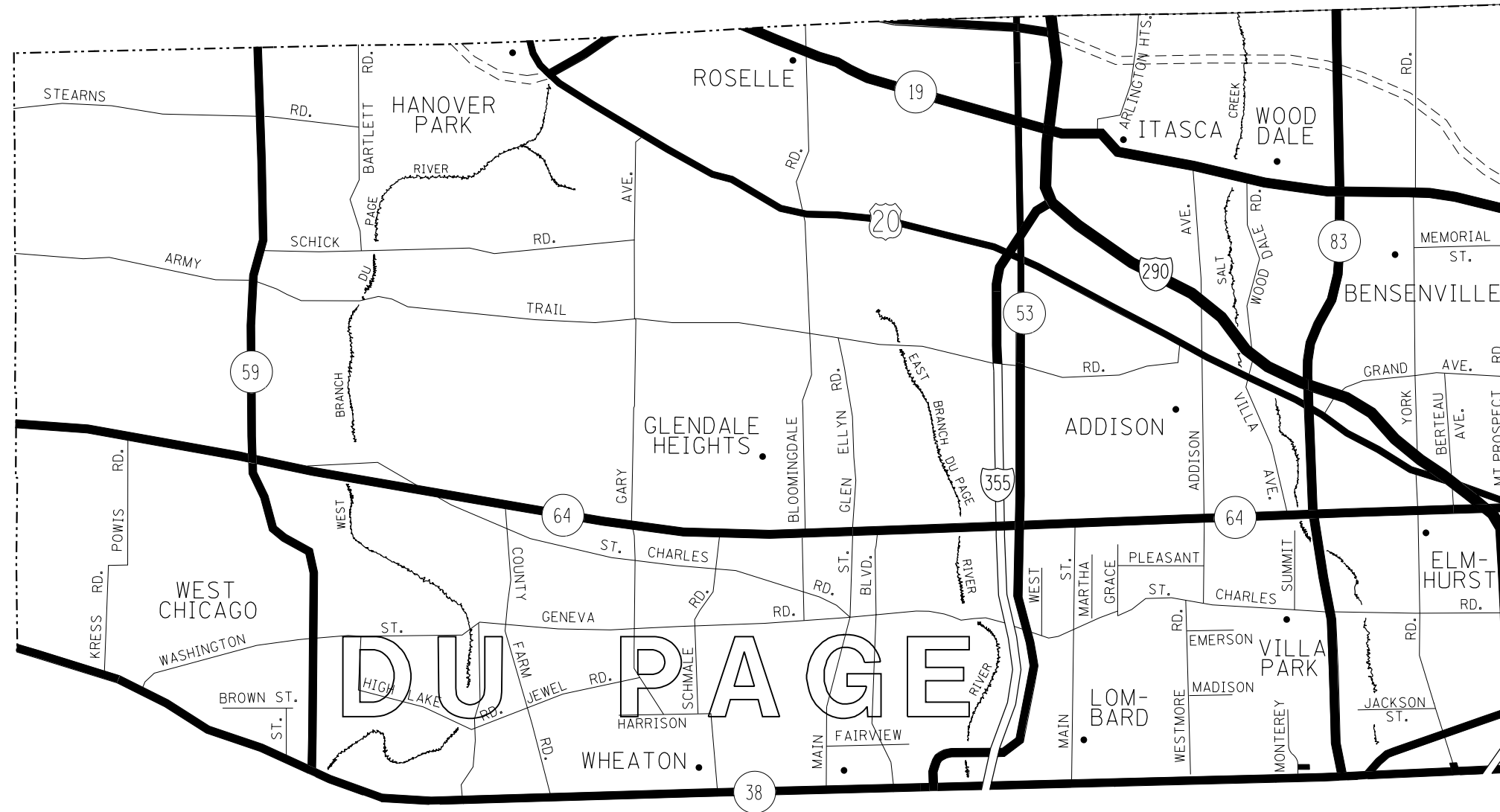

DISTRICT NO. 1
MAINTENANCE DESIGNATIONS

- VARIOUS COLORS STATE HIGHWAYS & EXPRESSWAYS
- TOLLWAY
- CITY MAINTENANCE AGREEMENTS
- FUTURE HIGHWAYS
- VARIOUS AGENCIES HIGHWAYS

FILE NAME =	USER NAME = midyja	DESIGNED -	REVISED -	STATE OF ILLINOIS DEPARTMENT OF TRANSPORTATION	FENCE REPAIR LOCATION MAP - DuPAGE COUNTY NORTH OF IL RTE 38	F.A. RTE.	SECTION	COUNTY	TOTAL SHEETS	SHEET NO.	
pw:\planroom.dot.illinois.gov\PIDOT\Documents\IDOT Offices\District 1\Projects\0144816\Drawings\Design\0144816-sht-plan.dgn						VAR	2020-245-1	VARIOUS	21	9	
PLOT SCALE = 100.0000' / 1" =						CONTRACT NO. 62N15					
Default						ILLINOIS FED. AID PROJECT					
PLOT DATE = 10/21/2020		DATE -	REVISED -	SCALE:	SHEET	OF	SHEETS	STA.	TO	STA.	

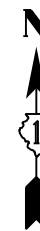
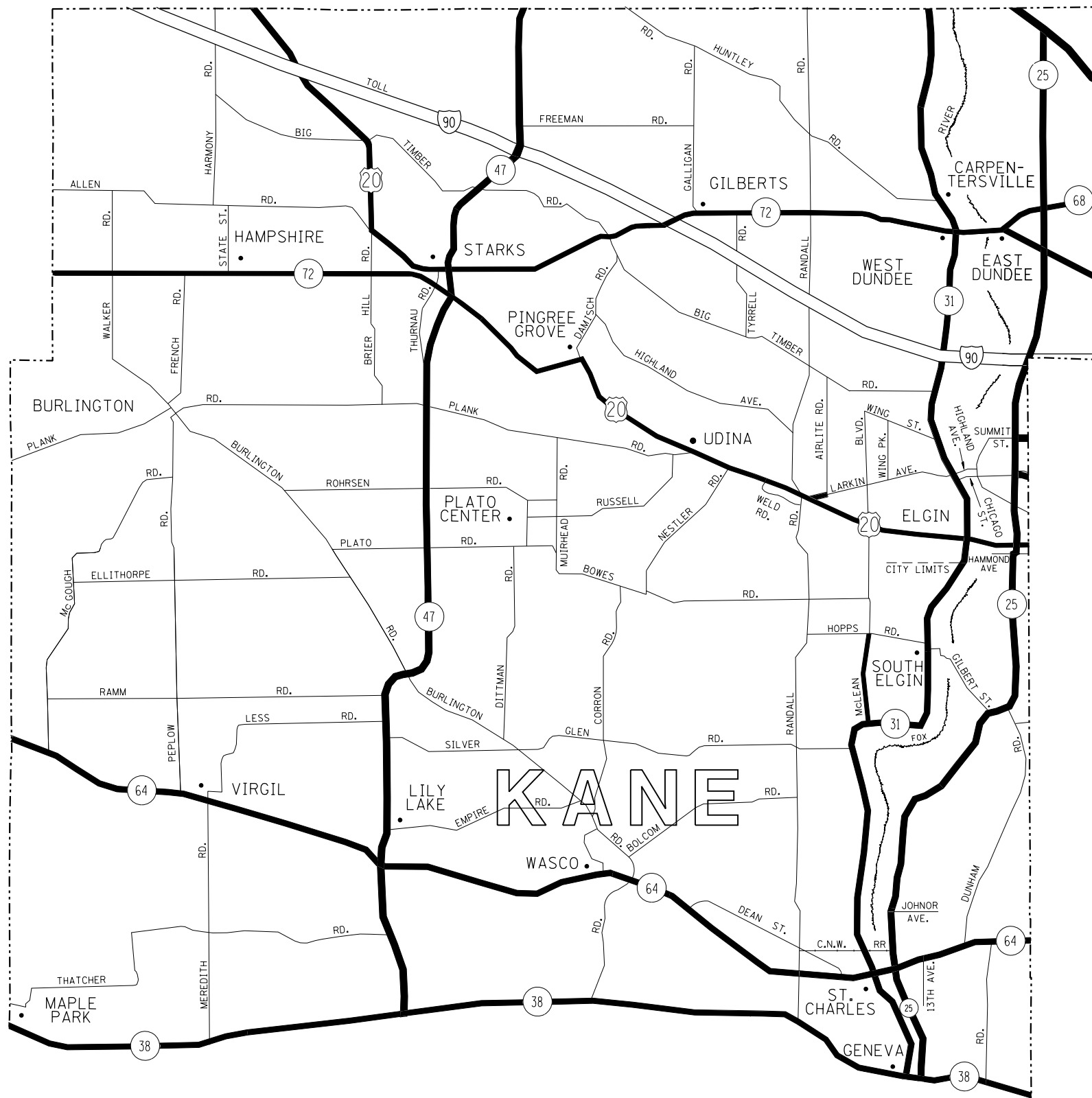

DISTRICT NO. 1
MAINTENANCE DESIGNATIONS

- VARIOUS COLORS STATE HIGHWAYS & EXPRESSWAYS
- TOLLWAY
- CITY MAINTENANCE AGREEMENTS
- FUTURE HIGHWAYS
- VARIOUS AGENCIES HIGHWAYS

FILE NAME =	USER NAME = midyja	DESIGNED -	REVISED -
p:\planroom\dot.illinois.gov\PWIDOT\Documents\IDOT Offices\District 1\Projects\0144816\Design\0144816-sht-plan.dgn		DRAWN -	REVISED -
Default	PLOT SCALE = 100.0000' / in.	CHECKED -	REVISED -
	PLOT DATE = 10/21/2020	DATE -	REVISED -

STATE OF ILLINOIS
DEPARTMENT OF TRANSPORTATION

FENCE REPAIR LOCATION MAP - KANE COUNTY
NORTH OF IL RTE 38

SCALE: SHEET OF SHEETS STA. TO STA.

F.A. RTE.	SECTION	COUNTY	TOTAL SHEETS	SHEET NO.
VAR	2020-245-1	VARIOUS	21	10
			CONTRACT NO. 62N15	
ILLINOIS FED. AID PROJECT				

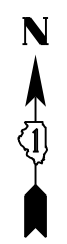
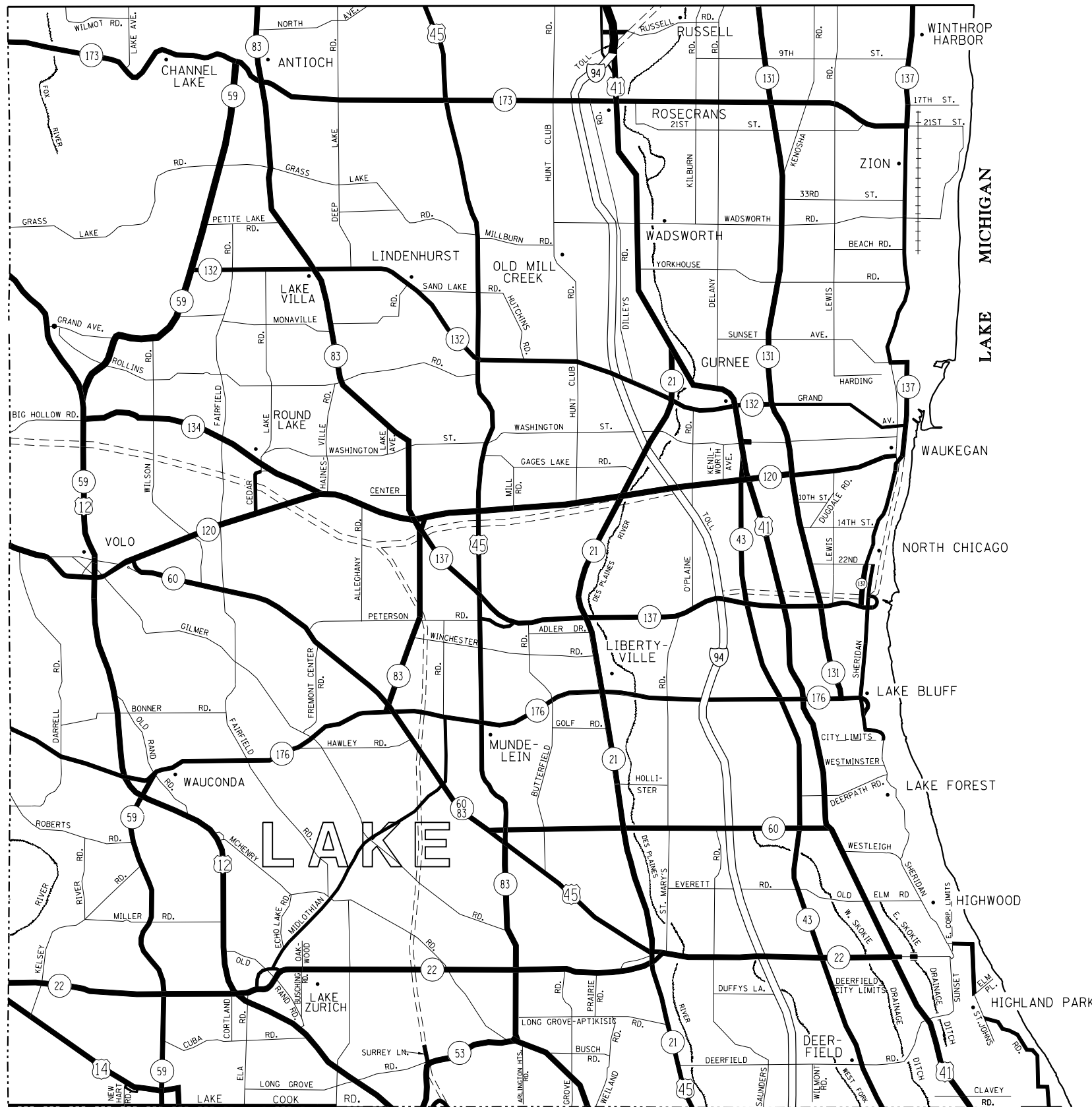

DISTRICT NO. 1 MAINTENANCE DESIGNATIONS

- VARIOUS COLORS STATE HIGHWAYS & EXPRESSWAYS
- TOLLWAY
- CITY MAINTENANCE AGREEMENTS
- FUTURE HIGHWAYS
- VARIOUS AGENCIES HIGHWAYS

FILE NAME =	USER NAME = midyja	DESIGNED -	REVISED -	STATE OF ILLINOIS DEPARTMENT OF TRANSPORTATION	FENCE REPAIR LOCATION MAP - LAKE COUNTY	F.A. RTE.	SECTION	COUNTY	TOTAL SHEETS	SHEET NO.	
pw:\planroom.dot.illinois.gov\PWIDOT\Documents\IDOT Offices\District 1\Projects\0144815\Drawings\Design\0144816-sht-plan.dgn		DRW				VAR	2020-245-1	VARIOUS	21	11	
Default	PLOT SCALE = 100.0000' / in.	CHECKED -	REVISED -			CONTRACT NO. 62N15					
	PLOT DATE = 10/21/2020	DATE -	REVISED -			SCALE:		SHEET OF SHEETS STA. TO STA.			
ILLINOIS FED. AID PROJECT											

NOTE

* MAXIMUM POST SPACING SHALL BE 3 m (10') C&C EXCEPT WHERE OTHERWISE SHOWN ON PLANS

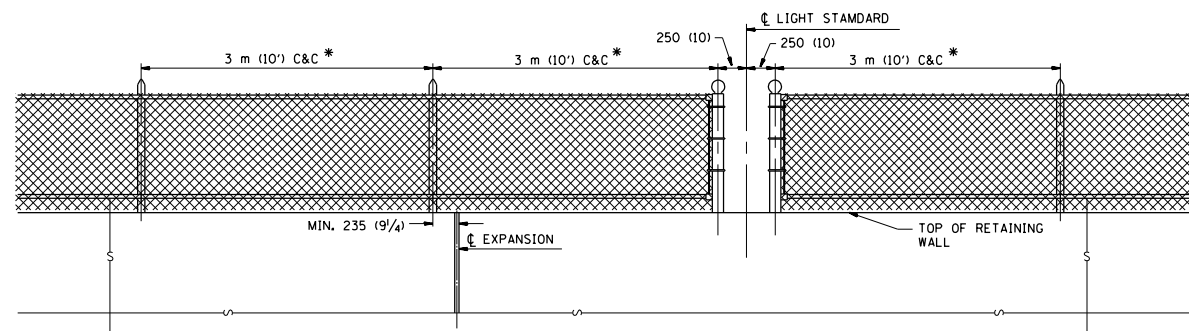

ELEVATION VIEW OF RETAINING WALL WITH PEDESTRIAN BARRIER TYPE III

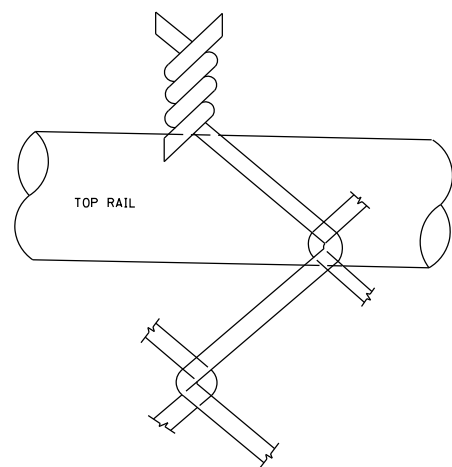

WIRE MESH FABRIC TO BE BARBED AT THE TOP

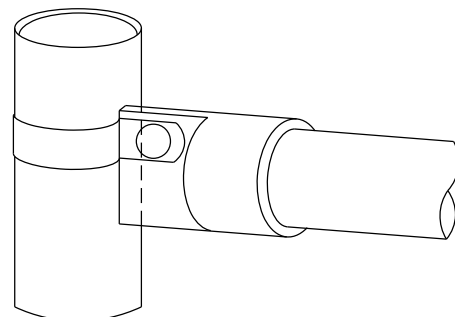

RAIL FITTING AT END POSTS

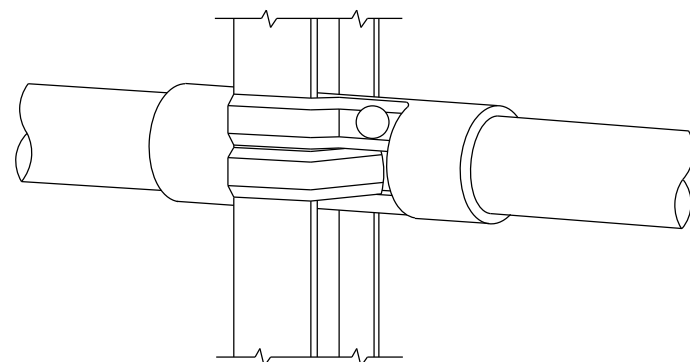

RAIL FITTING ON SECTION LINE POST

FOR INFORMATIONAL PURPOSES ONLY

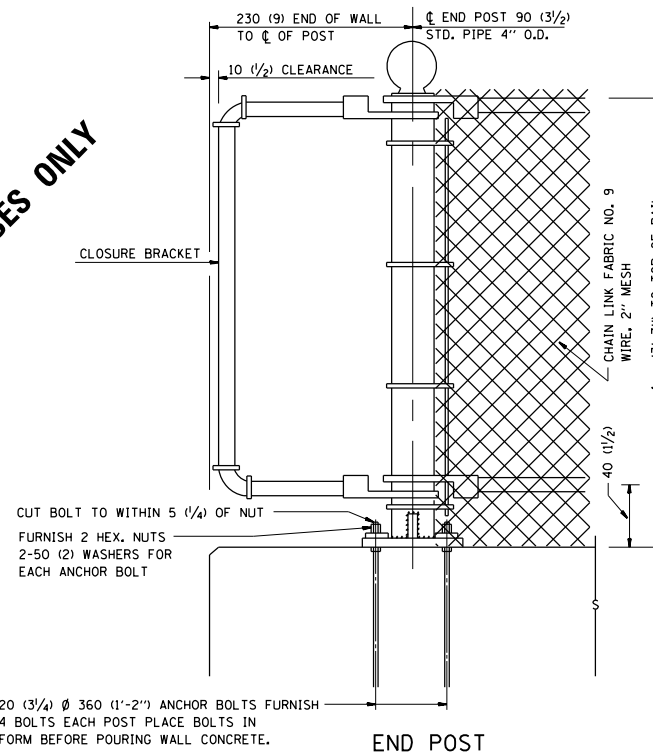

END POST

NOTE:
THE COST OF FURNISHING ANCHOR BOLTS, NUTS, & WASHERS TO BE INCIDENTAL

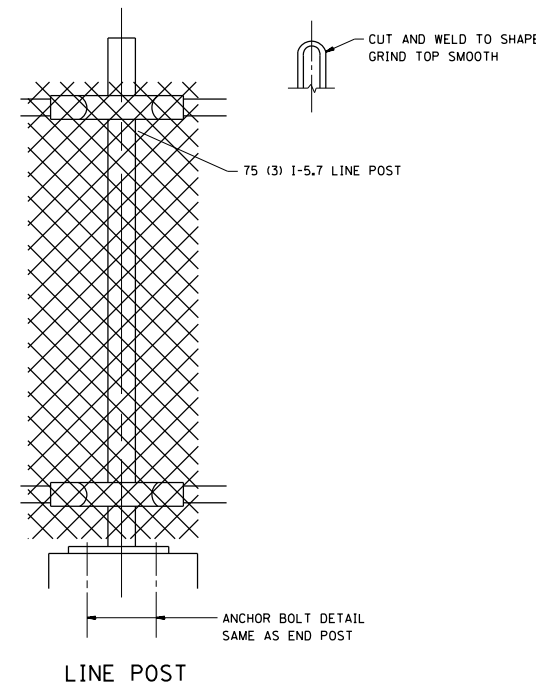

LINE POST

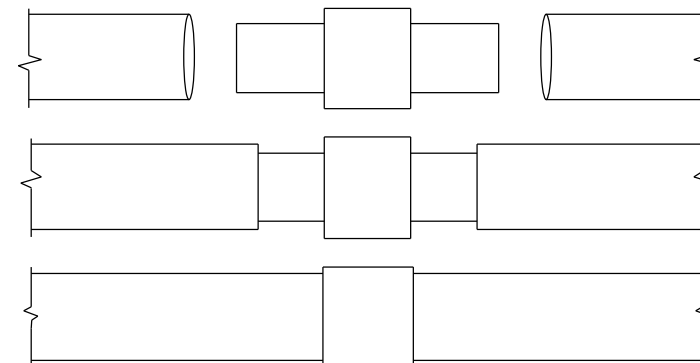

EXPANSION COUPLING DETAIL

NOTE:
EXP. COUPLING TO APPEAR IN TOP AND BOTTOM RAILS WHERE EVER EXP. JT. APPEARS IN STRUCTURE.

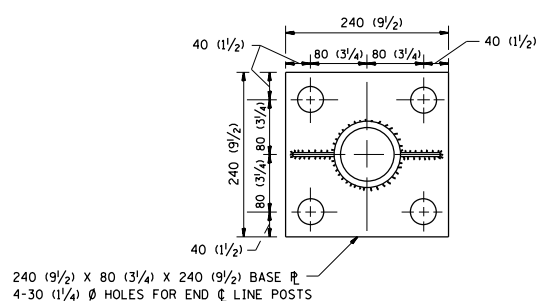

ANCHOR PLATE DETAILS

NOTE:
POST, PLATE AND GUSSET ASSEMBLY SHALL BE GALVANIZED AFTER ALL CUTTING, DRILLING, WELDING, AND FABRICATION HAVE BEEN COMPLETED. THE GALVANIZED COATING SHALL CONFORM TO THE REQUIREMENTS OF AASHTO M 120. THE GALVANIZED COATING SHALL NOT BE LESS THAN 610 G/SQ M (2.0 OZ./SQ. FT.) OF SURFACE.

ALL DIMENSIONS ARE IN MILLIMETERS (INCHES) UNLESS OTHERWISE SHOWN.

FILE NAME =	USER NAME = miduja	DESIGNED -	REVISED -	STATE OF ILLINOIS DEPARTMENT OF TRANSPORTATION	PEDESTRIAN BARRIER TYPE III STD. 10-SS-514 R	F.A. RTÉ.	SECTION	COUNTY	TOTAL SHEETS	SHEET NO.	
pw:\planroom.dot.illinois.gov\PIDOT\Documents\IDOT Offices\District 1\Projects\0144816\Drawings\Design\0144816-sht-plan.dgn	PLOT SCALE = 100.0000' / 1in.	CHECKED -	REVISED -			VAR	2020-245-1	VARIOUS	21	13	
PLOT DATE = 10/21/2020	DATE -	REVISED -	REVISED -			CONTRACT NO. 62N15					
						FED. ROAD DIST. NO.	ILLINOIS	FED. AID PROJECT			

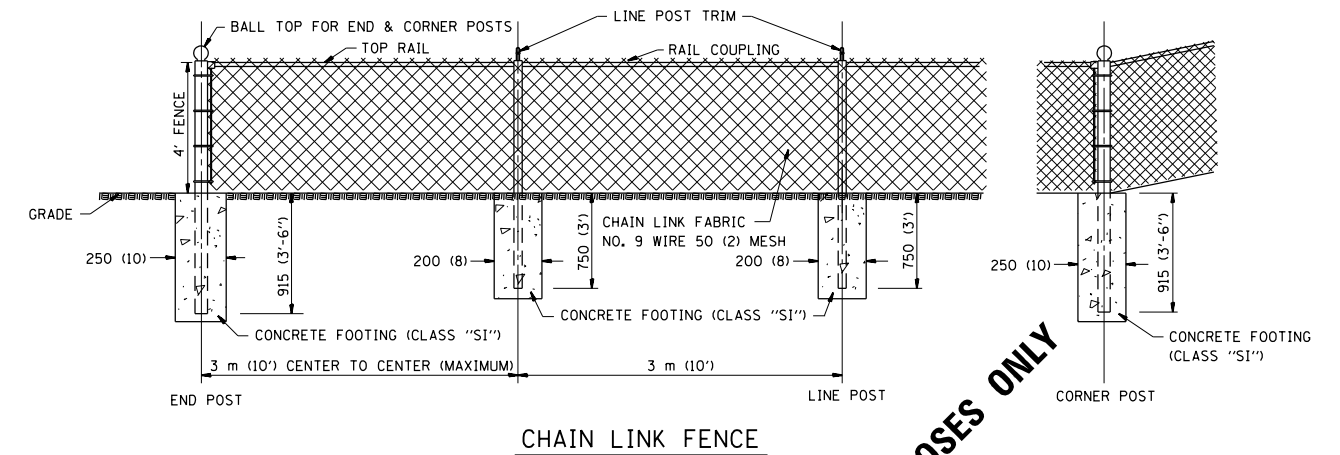

CHAIN LINK FENCE

FOR INFORMATIONAL PURPOSES ONLY

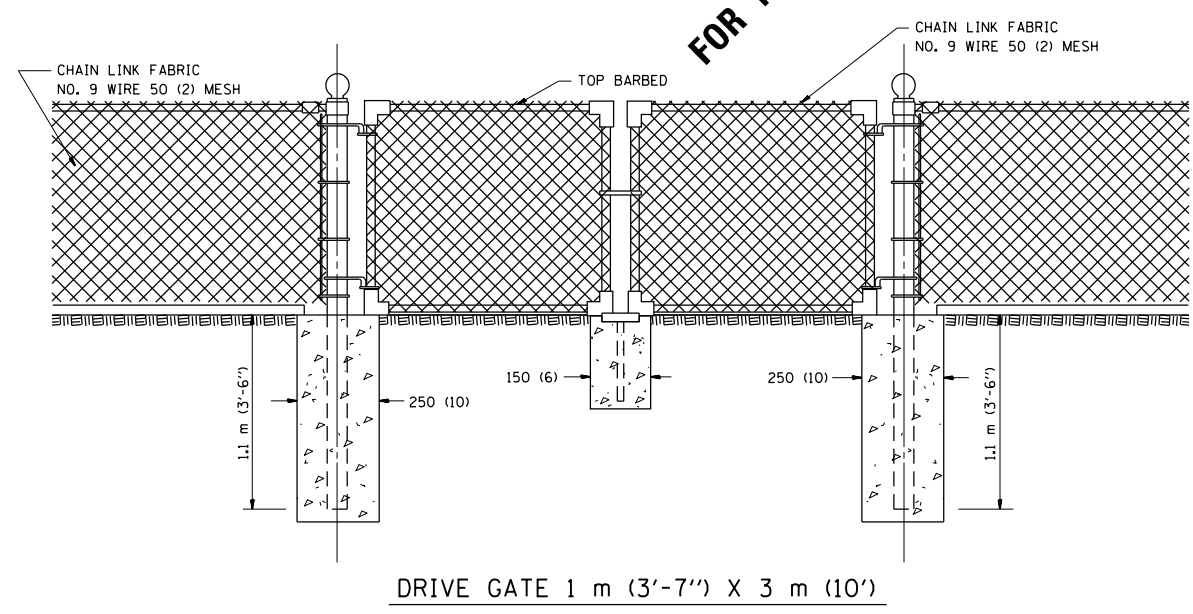

DRIVE GATE 1 m (3'-7") X 3 m (10')

ALL DIMENSIONS ARE IN MILLIMETERS (INCHES) UNLESS OTHERWISE SHOWN.

NOTE:
 THE CHAIN LINK FENCE AS SHOWN HEREIN SHALL BE CONSTRUCTED AT SUCH LOCATIONS AS SHOWN ON PLANS AND IN ACCORDANCE WITH THE SPECIAL PROVISIONS

 THE ENGINEER SHALL ESTABLISH ALL NECESSARY LINE AND GRADE PRIOR TO THE ERECTION OF THE FENCE IN CONFORMANCE WITH THE PLANS

FILE NAME =	USER NAME = midyja	DESIGNED -	REVISED -
p:\planroom.dot.illinois.gov\PIDOT\Documents\IDOT Offices\District 1\Projects\0144815\DRAWING\Design\0144816-sht-plan.dgn		DRAWN -	REVISED -
	PLOT SCALE = 100.0000' / 1m.	CHECKED -	REVISED -
	PLOT DATE = 10/21/2020	DATE -	REVISED -

STATE OF ILLINOIS
 DEPARTMENT OF TRANSPORTATION

CHAIN LINK FENCE
 STD. 10-SS-506 B

SCALE:	SHEET NO.	OF SHEETS	STA.	TO STA.
--------	-----------	-----------	------	---------

F.A. RTE.	SECTION	COUNTY	TOTAL SHEETS	SHEET NO.
VAR	2020-245-1	VARIOUS	21	14
CONTRACT NO. 62N15				
FED. ROAD DIST. NO. ILLINOIS FED. AID PROJECT				

GENERAL NOTES:

THIS WORK CONSISTS OF FURNISHING ALL LABOR, MATERIALS, TOOLS AND EQUIPMENT TO REPAIR CHAIN LINK FENCE POST SLEEVE AS SHOWN ON THE PLANS OR AS DIRECTED BY THE ENGINEER, AND IN ACCORDANCE WITH STATE STANDARD 664001.

BASIS OF PAVEMENT: THIS WORK SHALL BE PAID FOR AT THE CONTRACT UNIT PRICE EACH FOR "CHAIN LINK FENCE POST SLEEVE REPAIR" WHICH PRICE SHALL BE PAYMENT IN FULL TO COMPLETE THE WORK AS SPECIFIED HEREIN.

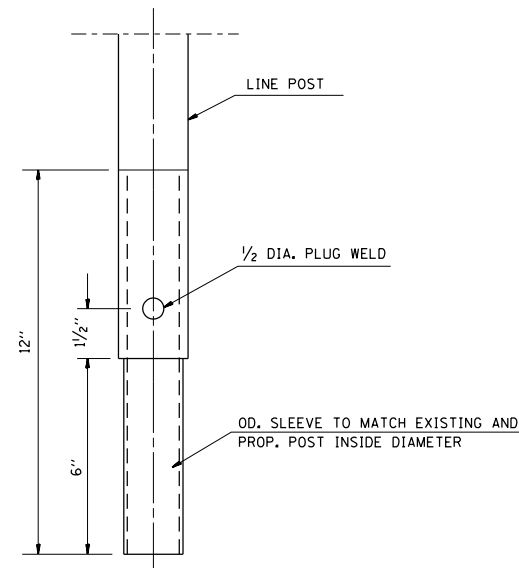
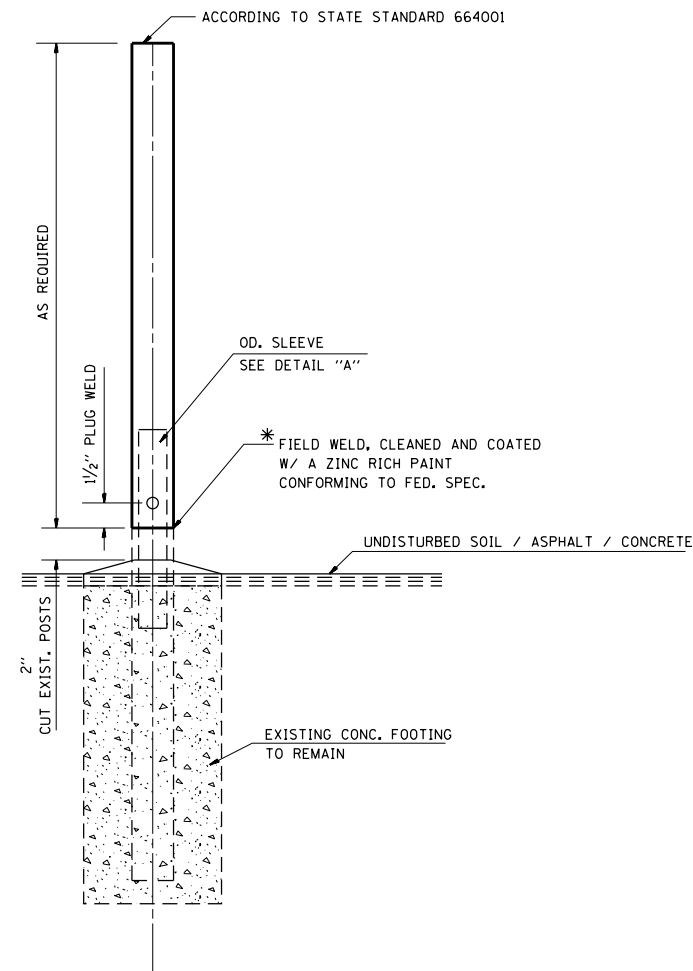

SLEEVE DET. DWG
DETAIL "A"
SLEEVE DETAIL

* THIS WORK SHALL BE INCLUDED IN THE COST OF THE PAY ITEM "CHAIN LINK FENCE POST SLEEVE REPAIR"

FILE NAME =	USER NAME = midyja	DESIGNED -	REVISED -
p:\planroom\dot.illinois.gov\PIDOT\Documents\IDOT Offices\District 1\Projects\0144815\DRAWING\Design\0144816-sht-plan.dgn		DRAWN -	REVISED -
PLOT SCALE = 100.0000' / 1in.	CHECKED -	REVISED -	REVISED -
PLOT DATE = 10/21/2020	DATE -	REVISED -	REVISED -

STATE OF ILLINOIS
DEPARTMENT OF TRANSPORTATION

CHAIN LINK FENCE POST SLEEVE
REPAIR DETAIL

SCALE: SHEET NO. OF SHEETS STA. TO STA.

F.A. RTE.	SECTION	COUNTY	TOTAL SHEETS	SHEET NO.
VAR	2020-245-1	VARIOUS	21	15
FED. ROAD DIST. NO. ILLINOIS FED. AID PROJECT			CONTRACT NO. 62N15	

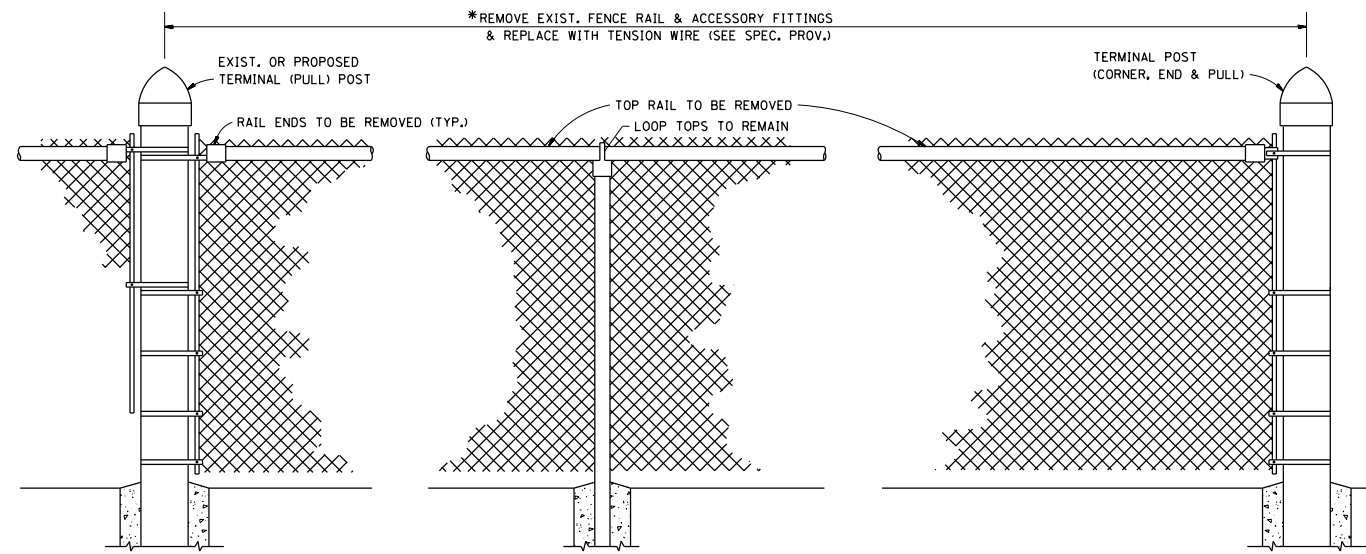

EXIST. CHAIN LINK FENCE WITH TOP RAIL

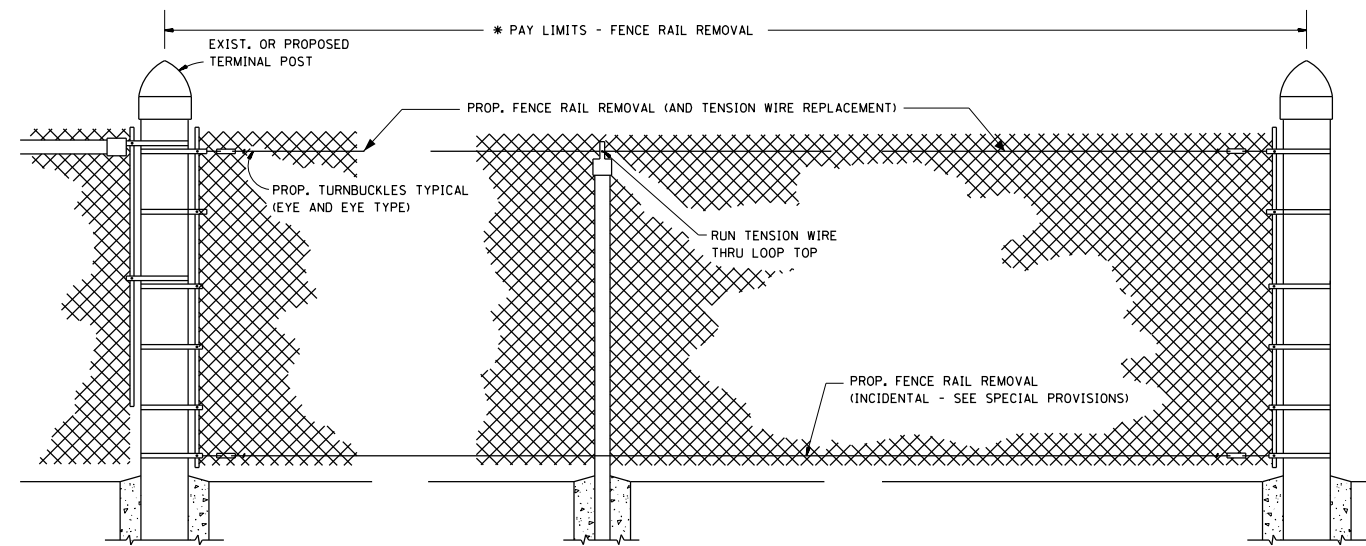

PROP. CHAIN LINK FENCE WITH "FENCE RAIL REMOVAL"

* THE ENGINEER IN CHARGE SHALL DETERMINE THE LENGTH OF FENCE RAIL TO BE REMOVED & REPLACED WITH "TENSION WIRE"

GENERAL NOTES

FENCE RAIL REMOVAL: THIS ITEM CONSISTS OF REMOVING EXISTING TOP OR BOTTOM RAIL, (DAMAGED OR UNDAMAGED) AND REPLACING WITH TENSION WIRE. BOTTOM TENSION WIRE SHALL BE CONSIDERED INCIDENTAL EXCEPT AT LOCATIONS OF EXISTING BOTTOM RAIL REMOVAL.

TENSION WIRE: THIS ITEM CONSISTS OF INSTALLING TENSION WIRE, TOP OR BOTTOM, WHERE TOP OR BOTTOM RAIL IS NON-EXISTENT, OR WHERE EXISTING DAMAGED TENSION WIRE IS REMOVED AND REPLACED BY NEW TENSION WIRE.

ALL WORK AND MATERIALS SHALL BE IN ACCORDANCE WITH THE PLANS, SPECIAL PROVISIONS, STANDARD SPECIFICATIONS AND STANDARD 664001.

REPLACEMENT OF OTHER FENCE COMPONENT PARTS SHALL BE MEASURED AND PAID FOR SEPARATELY AS DESCRIBED IN THE SPECIAL PROVISIONS.

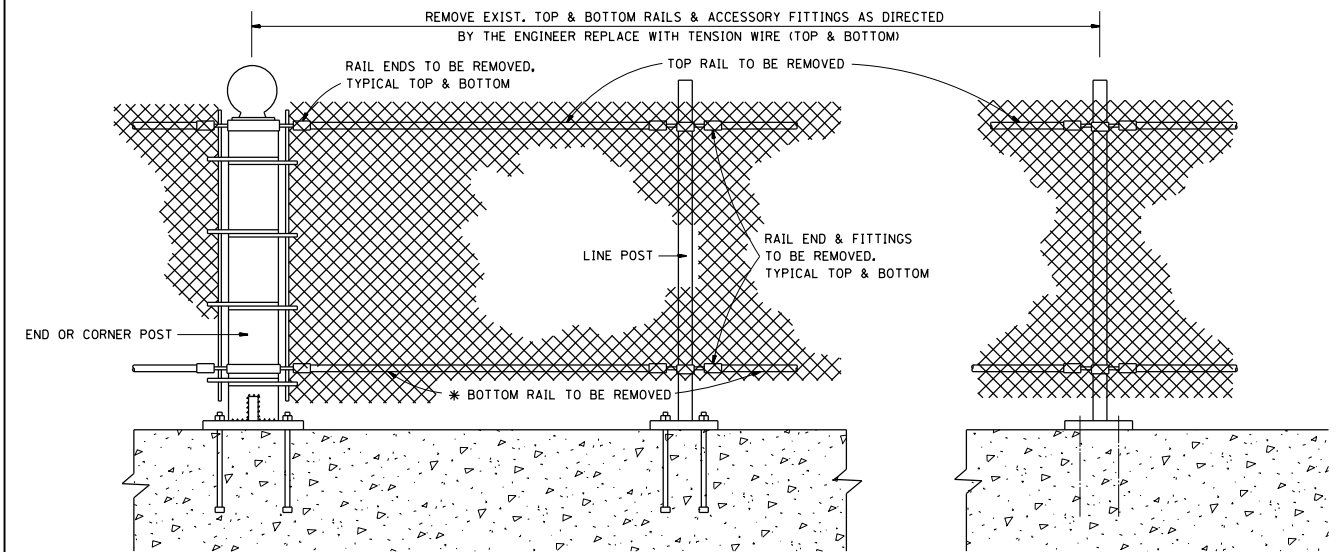

EXIST. PEDESTRIAN BARRIER TYPE 3 WITH TOP AND BOTTOM RAILS

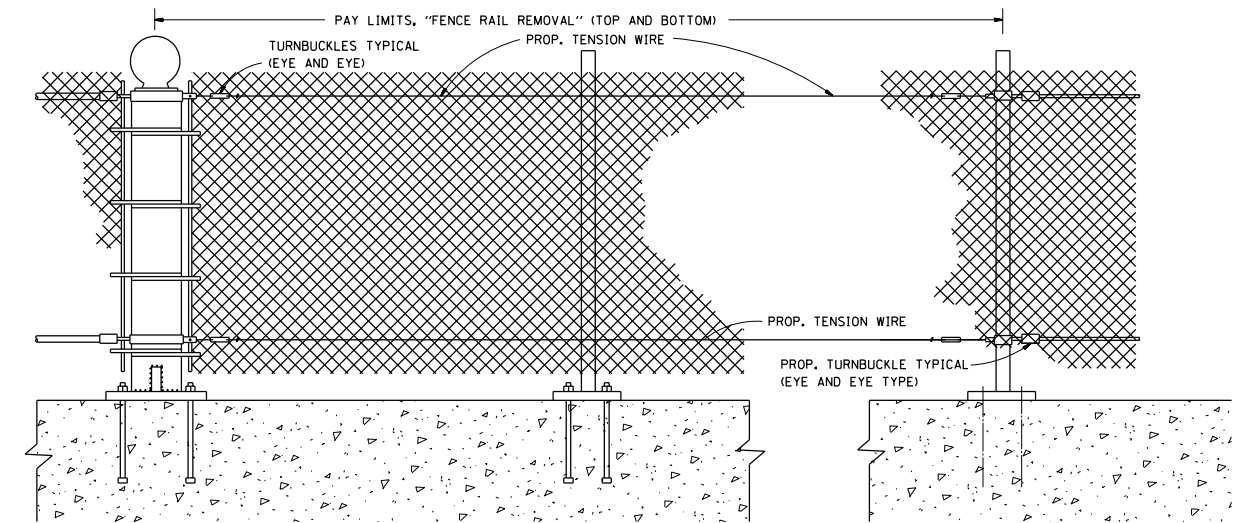

PROP. PEDESTRIAN BARRIER TYPE 3 WITH FENCE RAIL REMOVAL

ALL DIMENSIONS ARE IN MILLIMETERS (INCHES) UNLESS OTHERWISE SHOWN.

FILE NAME =	USER NAME = midyja	DESIGNED -	REVISED -
pw:\planroom.dot.illinois.gov\PIDOT\Documents\IDOT Offices\District 1\Projects\0144815\DRAWING\Design\0144816-sht-plan.dgn		DRAWN -	REVISED -
	PLOT SCALE = 100.0000' / 1in.	CHECKED -	REVISED -
	PLOT DATE = 10/21/2020	DATE -	REVISED -

**STATE OF ILLINOIS
DEPARTMENT OF TRANSPORTATION**

**PROPOSED PEDESTRIAN BARRIER AND
CHAIN LINK FENCE WITH TENSION WIRE AND FENCE RAIL REMOVAL**

SCALE: SHEET NO. OF SHEETS STA. TO STA.

F.A. RTE.	SECTION	COUNTY	TOTAL SHEETS	SHEET NO.
VAR	2020-245-1	VARIOUS	21	16
CONTRACT NO. 62N15				
FED. ROAD DIST. NO. ILLINOIS FED. AID PROJECT				

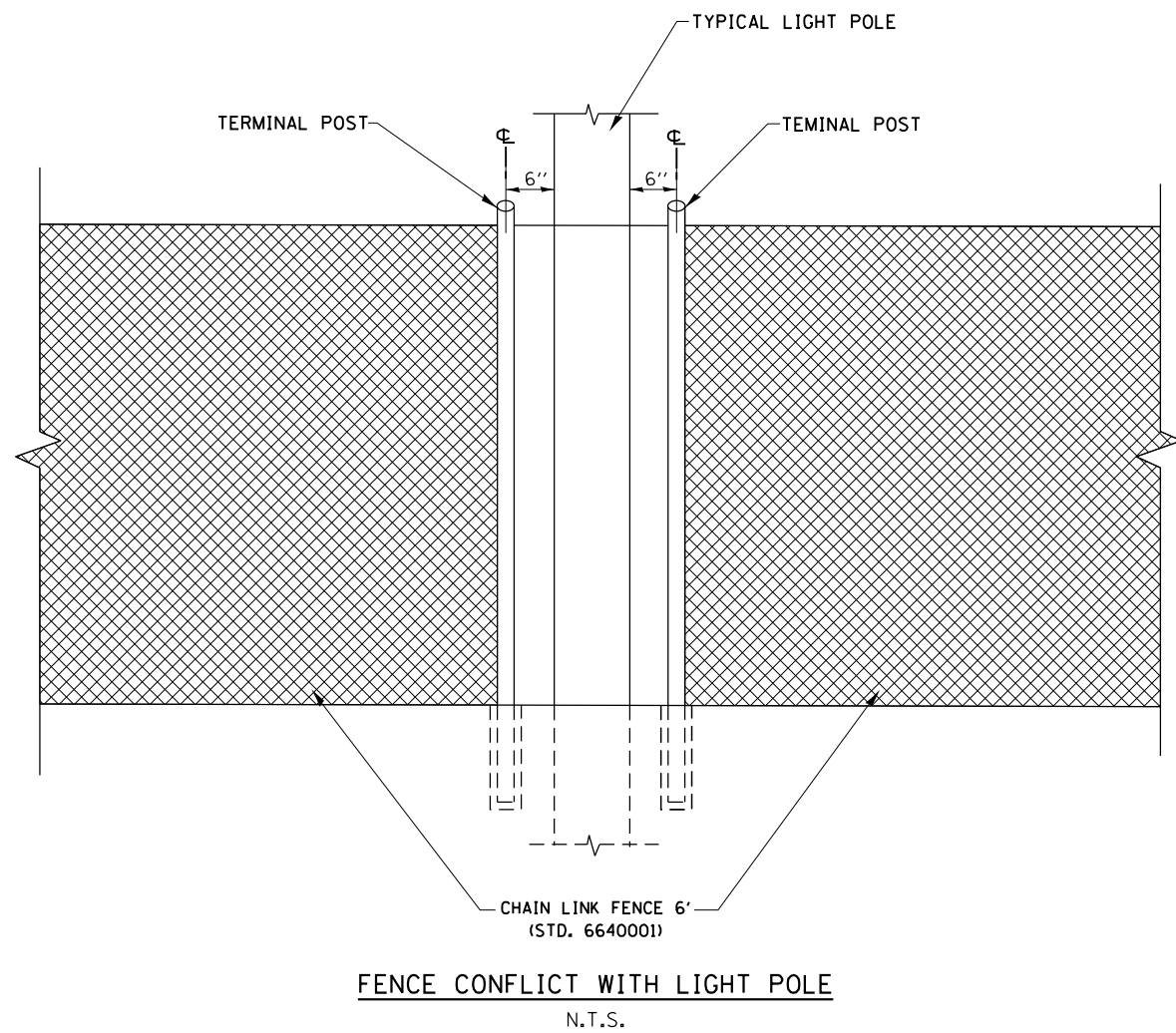

GALVANIZED POSTS SHALL CONFORM TO THE REQUIREMENTS OF STANDARD 864001 POSTS UTILIZED IN THE REPAIR WORK SHALL BE THE SAME TYPE SHAPE AS POSTS ADJACENT TO THE REPAIR AREA UNLESS OTHERWISE DIRECTED BY THE ENGINEER. NO USED MATERIALS WILL BE PERMITTED.

REMOVAL OF EXISTING FENCE POSTS BY DRILLING OR CORING AND GROUTING A NEW FENCE POST (LINE TERMINAL, END CORNER AND GATE) IN ACCORDANCE WITH THE APPLICABLE PORTIONS OF SECTIONS 664 AND 1025 OF THE STANDARD SPECIFICATIONS.

EXISTING LOCATION POST MUST BE USED. NO NEW POST HOLES WILL BE ALLOWED.

EXIST. CONC. POST FOUNDATION

EXIST. CONC. PAD

1/4" - 1/2" MIN.

POST REMOVAL AND REPLACEMENT SHALL BE FULL DEPTH.

POST REMOVAL AND REPLACEMENT

FILE NAME =	USER NAME = midyja	DESIGNED -	REVISED -
p:\planroom.dot.illinois.gov\PWIDOT\Documents\IDOT Offices\District 1\Projects\0144816\DRAWING\Design\0144816-sht-plan.dgn		DRAWN -	REVISED -
Default	PLOT SCALE = 100.0000' / 1in.	CHECKED -	REVISED -
	PLOT DATE = 10/21/2020	DATE -	REVISED -

**STATE OF ILLINOIS
DEPARTMENT OF TRANSPORTATION**

SPECIAL FENCE DETAILS

SCALE: SHEET OF SHEETS STA. TO STA.

F.A. RTE.	SECTION	COUNTY	TOTAL SHEETS	SHEET NO.
VAR	2020-245-1	VARIOUS	21	17
			CONTRACT NO. 62N15	
ILLINOIS FED. AID PROJECT				

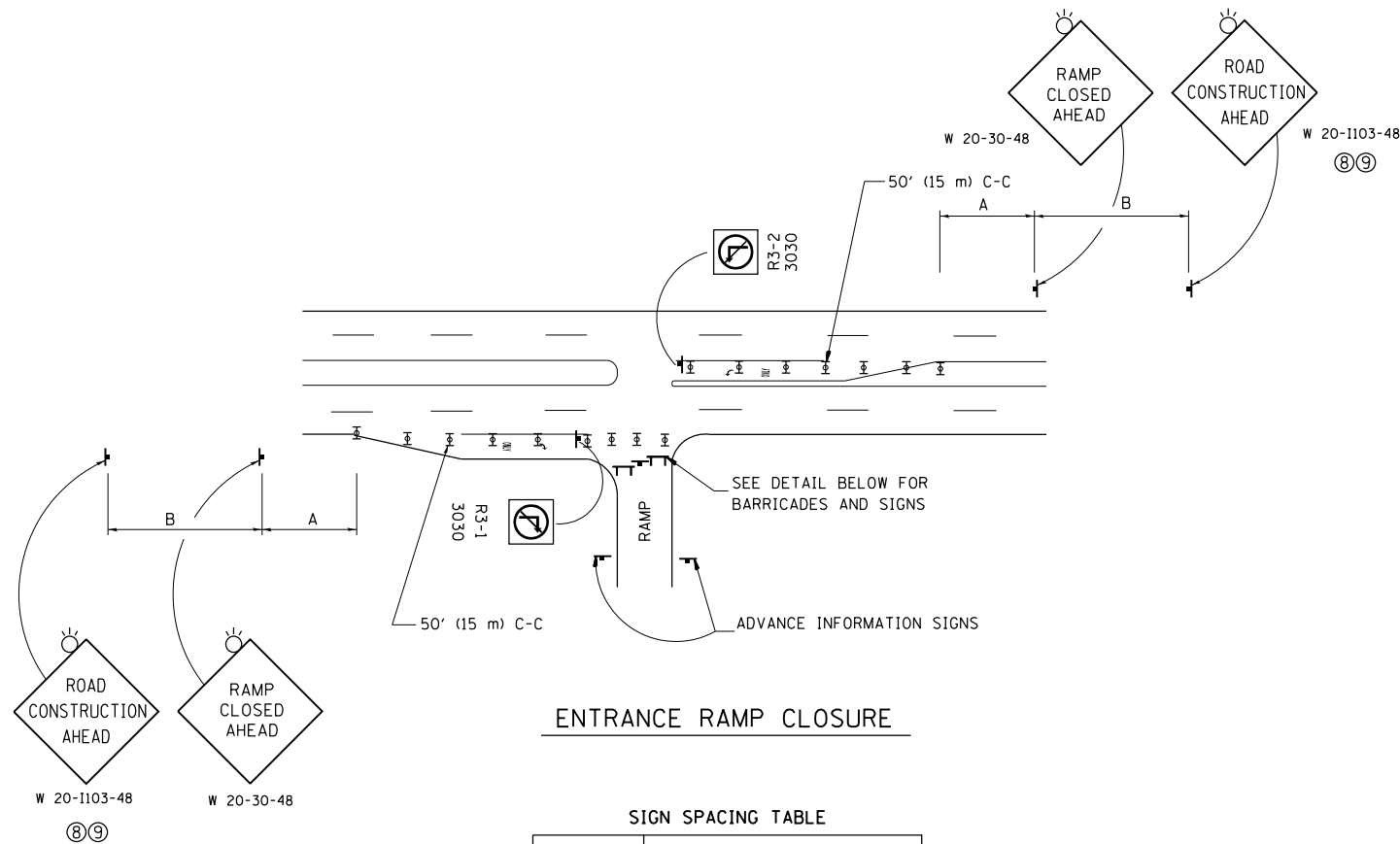

ENTRANCE RAMP CLOSURE

SIGN SPACING TABLE

FACILITY	DISTANCE BETWEEN SIGNS	
	A	B
EXPRESSWAY >24 HOURS	1000' (300 m)	1500' (450 m)
EXPRESSWAY <24 HOURS	500' (150 m)	500' (150 m)
ARTERIAL 55 MPH	500' (150 m)	500' (150 m)
ARTERIAL 50-45 MPH	350' (100 m)	350' (100 m)
ARTERIAL <45 MPH	200' (60 m)	200' (60 m)

DISTANCES MAY BE SHORTENED DEPENDING UPON THE PROXIMITY OF ADJACENT RAMPS OR INTERSECTIONS.

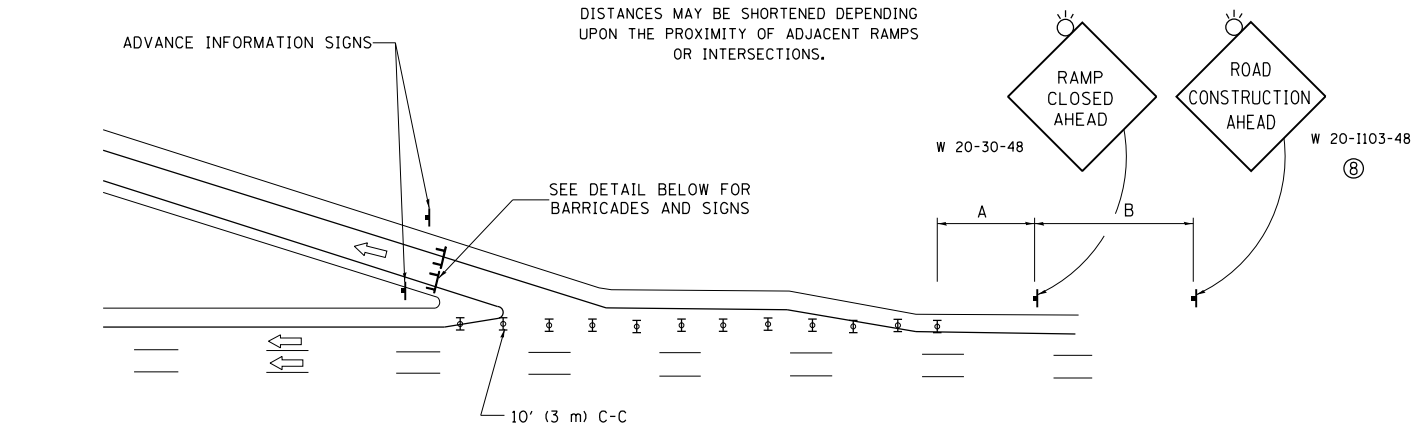

EXIT RAMP CLOSURE

SYMBOLS

- ⊥ TYPE II BARRICADE OR DRUM
- ⊓ TYPE III BARRICADE WITH 2 FLASHING LIGHTS

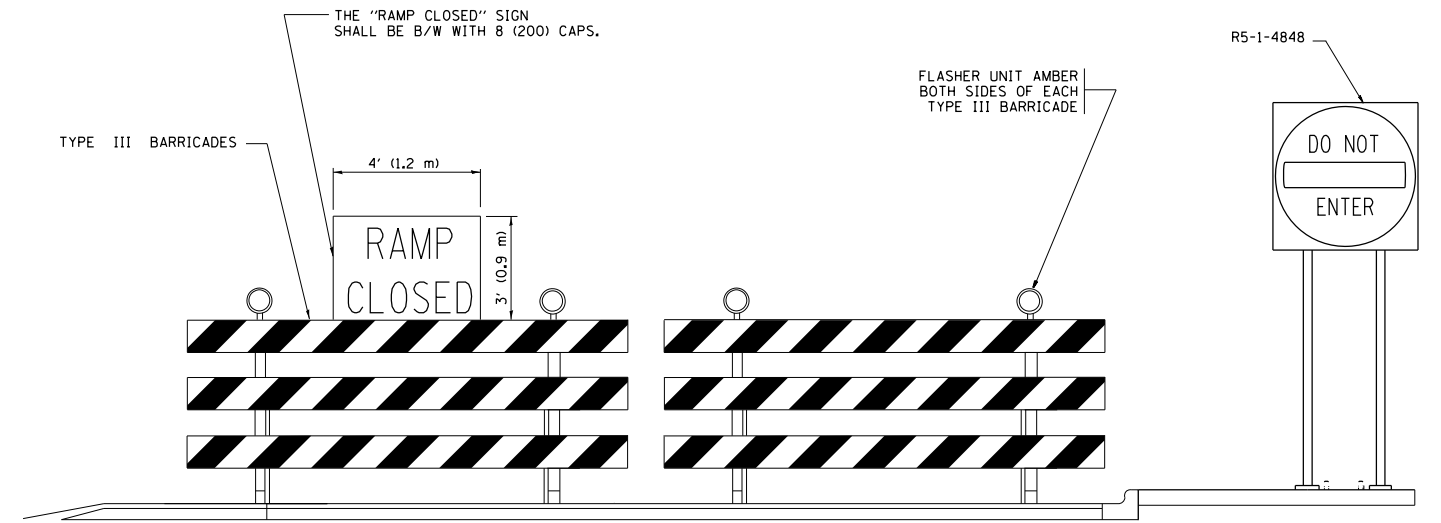

DETAIL FOR REQUIRED BARRICADES & SIGNS

RAMP CLOSURE ADVANCE WARNING SIGN

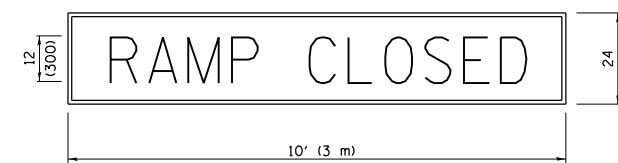

BLACK LEGEND ON ORANGE BACKGROUND MOUNTED DIAGONALLY
E MOD FONT
1 (25) BORDER

THESE SIGNS ARE REQUIRED ON ALL THE EXIT GUIDE SIGNS FOR EXIT RAMPS THAT WILL BE CLOSED FOR MORE THAN FOUR (4) CONSECUTIVE DAYS.

RAMP CLOSURE ADVANCE INFORMATION SIGN

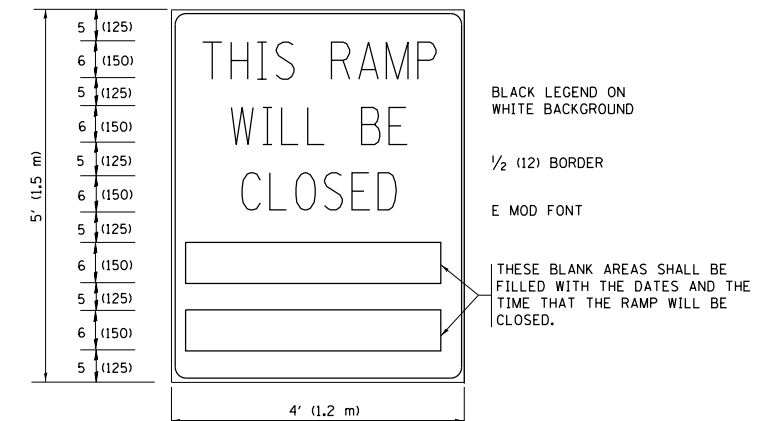

BLACK LEGEND ON WHITE BACKGROUND

1/2 (12) BORDER

E MOD FONT

THESE BLANK AREAS SHALL BE FILLED WITH THE DATES AND THE TIME THAT THE RAMP WILL BE CLOSED.

THESE SIGNS ARE REQUIRED ON BOTH SIDES OF THE RAMP, MINIMUM OF 1 WEEK IN ADVANCE OF THE CLOSURE.

THESE SIGNS SHALL BE FABRICATED AND PAID FOR ACCORDING TO THE TEMPORARY INFORMATION SIGNING SPECIAL PROVISION

GENERAL NOTES:

- ① CONES MAY BE SUBSTITUTED FOR DRUMS OR TYPE II BARRICADES DURING DAY OPERATIONS. CONES SHALL BE A MINIMUM OF 28 (700) HIGH.
- ② VERTICAL BARRICADES SHALL NOT BE USED FOR RAMP CLOSURES.
- ③ A FLAGGER SHALL BE POSITIONED AT EACH CLOSED RAMP THAT IS OPEN TO CONSTRUCTION VEHICLES, PRECEDED BY A W20-7 FLAGGER WARNING SIGN.
- ④ ALL ROUTE MARKERS AND TRAILBLAZER ASSEMBLIES WHICH DIRECT MOTORISTS TO A CLOSED ENTRANCE RAMP SHALL BE COVERED WHEN THE RAMP IS CLOSED FOR MORE THAN FOUR (4) DAYS.
- ⑤ THE SIGNING AND BARRICADING WHICH IS REQUIRED BY THIS DETAIL SHALL BE INCLUDED IN THE COST OF TRAFFIC CONTROL AND PROTECTION (EXPRESSWAYS).
- ⑥ AUTHORIZATION FROM THE DISTRICT'S BUREAU OF TRAFFIC IS REQUIRED FOR ALL RAMP CLOSURES.
- ⑦ THE RAMP CLOSURE ADVANCE INFORMATION SIGNS SHALL BE ERECTED IF THE CLOSURE TIME EXCEEDS TWENTY-FOUR (24) HOURS. ADDITIONAL ADVANCE WARNING SIGNS ON EXIT GUIDE SIGNING WILL BE REQUIRED FOR EXIT RAMP CLOSURES THAT EXCEED FOUR (4) DAYS IN LENGTH.
- ⑧ ROAD CONSTRUCTION AHEAD SIGNS MAY BE OMITTED WHEN THIS DETAIL IS USED IN CONJUNCTION WITH OTHER TRAFFIC CONTROL THAT ALREADY INCLUDES A ROAD CONSTRUCTION AHEAD SIGN.
- ⑨ ARTERIAL ROAD CONSTRUCTION AHEAD SIGNS SHALL BE INSTALLED ON THE LEFT SIDE OF TRAFFIC IF THE MEDIAN IS MORE THAN 10 FT WIDE.

ALL DIMENSIONS ARE IN INCHES (MILLIMETERS) UNLESS OTHERWISE SHOWN.

FILE NAME =	USER NAME = midyja	DESIGNED - D.W.S.	REVISED - S.P.B. 01-07
pw:\planroom.dot.illinois.gov\PIDOT\Documents\IDOT Offices\District 1\Projects\0144816\Drawn\Design\0144816-sht-plan.dgn		CHECKED -	REVISED - S.P.B. 12-09
Default	PLOT SCALE = 100.0000' / 1in.	DATE - 02-83	REVISED - M.D. 06-13
	PLOT DATE = 10/21/2020		REVISED - M.D. 01-18

**STATE OF ILLINOIS
DEPARTMENT OF TRANSPORTATION**

**ENTRANCE AND EXIT RAMP
CLOSURE DETAILS**

SCALE: NONE SHEET 1 OF 1 SHEETS STA. TO STA.

F.A. RTÉ.	SECTION	COUNTY	TOTAL SHEETS	SHEET NO.
VAR.	2020-245-1	VARIOUS	21	18
TC-08			CONTRACT NO. 62N15	
ILLINOIS FED. AID PROJECT				

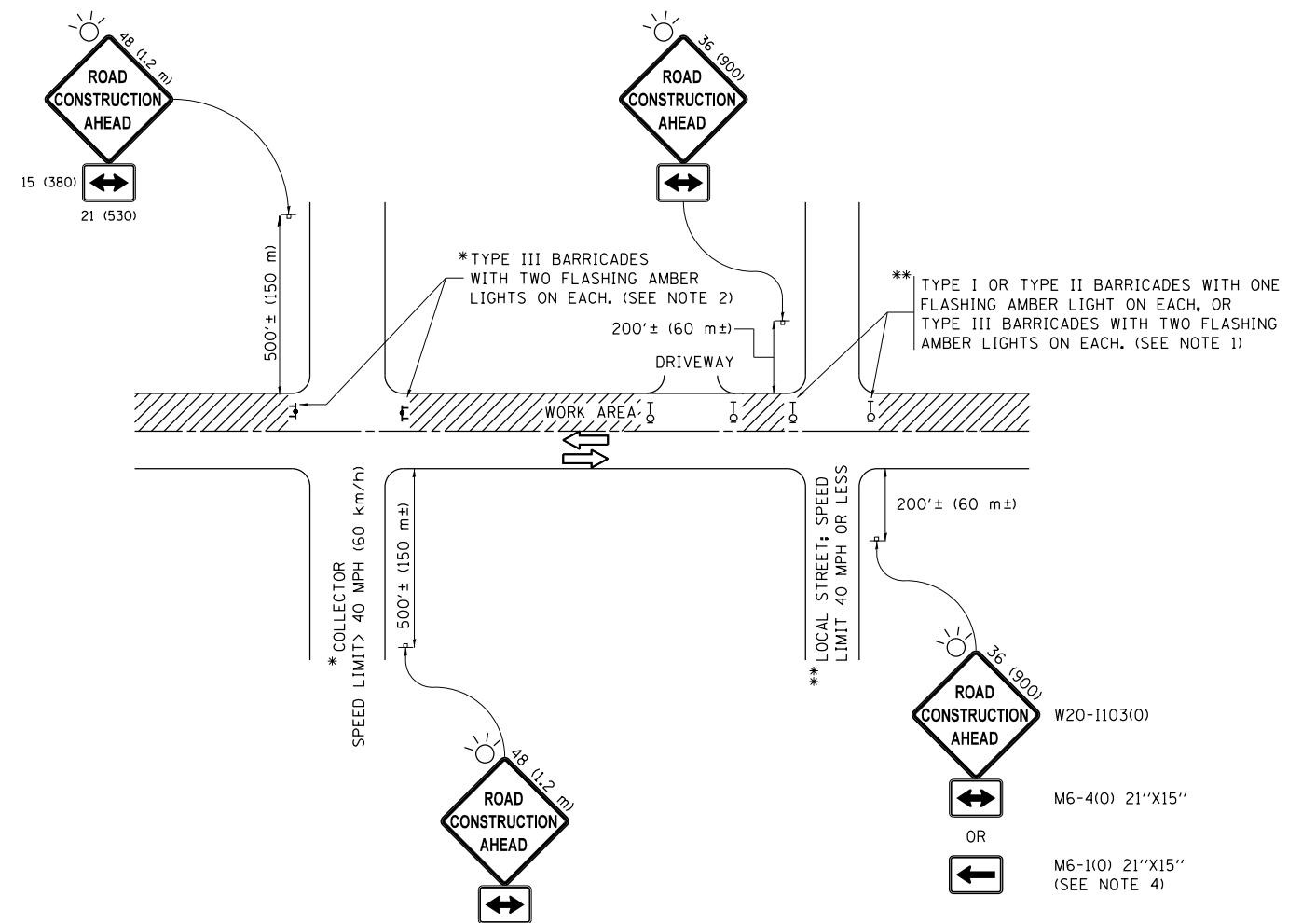

NOTES:

1. SIDE ROAD WITH A SPEED LIMIT OF 40 MPH (60 km/h) OR LESS AS SHOWN ON THE DRAWING AND AS DIRECTED BY THE ENGINEER:
 - a) ONE "ROAD CONSTRUCTION AHEAD" SIGN 36 x 36 (900x900) WITH A FLASHER MOUNTED ON IT APPROXIMATELY 200' (60 m) IN ADVANCE OF THE MAIN ROUTE.
 - b) THE CLOSED PORTION OF THE MAIN ROUTE SHALL BE PROTECTED BY BLOCKING WITH TYPE I, TYPE II OR TYPE III BARRICADES, 1/3 OF THE CROSS SECTION OF THE CLOSED PORTION.
2. SIDE ROAD WITH A SPEED LIMIT GREATER THAN 40 MPH (60 km/h) AS SHOWN ON THE DRAWING AND AS DIRECTED BY THE ENGINEER:
 - a) ONE "ROAD CONSTRUCTION AHEAD" SIGN 48 x 48 (1.2 m x 1.2 m) WITH A FLASHER MOUNTED ON IT APPROXIMATELY 500' (150 m) IN ADVANCE OF THE MAIN ROUTE.
 - b) THE CLOSED PORTION OF THE MAIN ROUTE SHALL BE PROTECTED BY BLOCKING WITH TYPE III BARRICADES, 1/2 OF THE CROSS SECTION OF THE CLOSED PORTION.
3. CONES MAY BE SUBSTITUTED FOR BARRICADES OR DRUMS AT HALF THE SPACING DURING DAY OPERATIONS. CONES SHALL BE A MINIMUM OF 28 (710) IN HEIGHT.
4. WHEN THE SIDE ROAD LIES BETWEEN THE BEGINNING OF THE MAINLINE SIGNING AND THE WORK ZONE, A SINGLE HEADED ARROW (M6-1) SHALL BE USED IN LIEU OF THE DOUBLE HEADED ARROW (M6-4).
5. WHEN WORK IS BEING PERFORMED ON A SIDE ROAD OR DRIVEWAY, FOLLOW THE APPLICABLE STANDARD(S). THE DIRECTIONAL ARROW (M6-1 OR M6-4) SHALL BE COVERED OR REMOVED WHEN NO LONGER CONSISTENT WITH THE TRAFFIC CONTROL SET-UP.
6. ADVANCE WARNING SIGNS ARE TO BE OMITTED ON DRIVEWAYS UNLESS OTHERWISE SPECIFIED IN THE PLANS OR BY THE ENGINEER.
7. THE TRAFFIC CONTROL AND PROTECTION FOR SIDE ROADS, INTERSECTIONS, AND DRIVEWAYS SHALL BE INCLUDED IN THE COST OF SPECIFIED TRAFFIC CONTROL STANDARDS OR ITEMS.

All dimensions are in inches (millimeters) unless otherwise shown.

FILE NAME =	USER NAME = midyja	DESIGNED - L.H.A.	REVISED - A. HOUSEH 10-15-96
pw:\planroom.dot.illinois.gov\PIDOT\Documents\IDOT Offices\District 1\Projects\0144815\DRAWING\Design\0144816-sht-plan.dgn		DRAWN -	REVISED - T. RAMMACHER 01-06-00
Default	PLOT SCALE = 100.0000' / in.	CHECKED -	REVISED - A. SCHUETZE 07-01-13
	PLOT DATE = 10/21/2020	DATE - 06-89	REVISED - A. SCHUETZE 09-15-16

**STATE OF ILLINOIS
DEPARTMENT OF TRANSPORTATION**

**TRAFFIC CONTROL AND PROTECTION FOR
SIDE ROADS, INTERSECTIONS, AND DRIVEWAYS**

SCALE: NONE SHEET 1 OF 1 SHEETS STA. TO STA.

F.A. RTE.	SECTION	COUNTY	TOTAL SHEETS	SHEET NO.
VAR.	2020-245-1	VARIOUS	21	19
TC-10			CONTRACT NO. 62N15	
ILLINOIS FED. AID PROJECT				

TURN BAY ENTRANCE AT START OF LANE CLOSURE TAPER

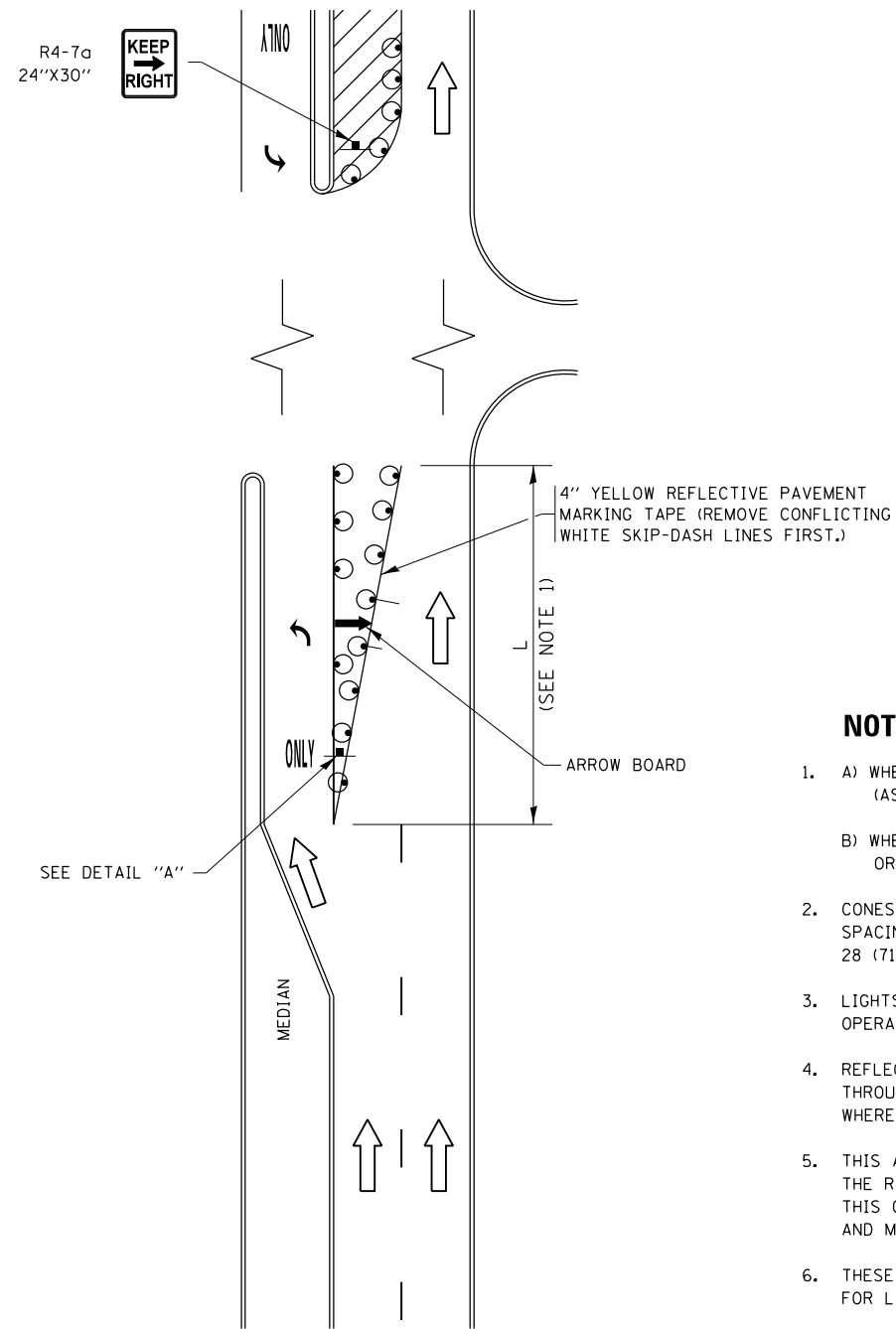

FIGURE 1

TURN BAY ENTRANCE WITHIN A LANE CLOSURE

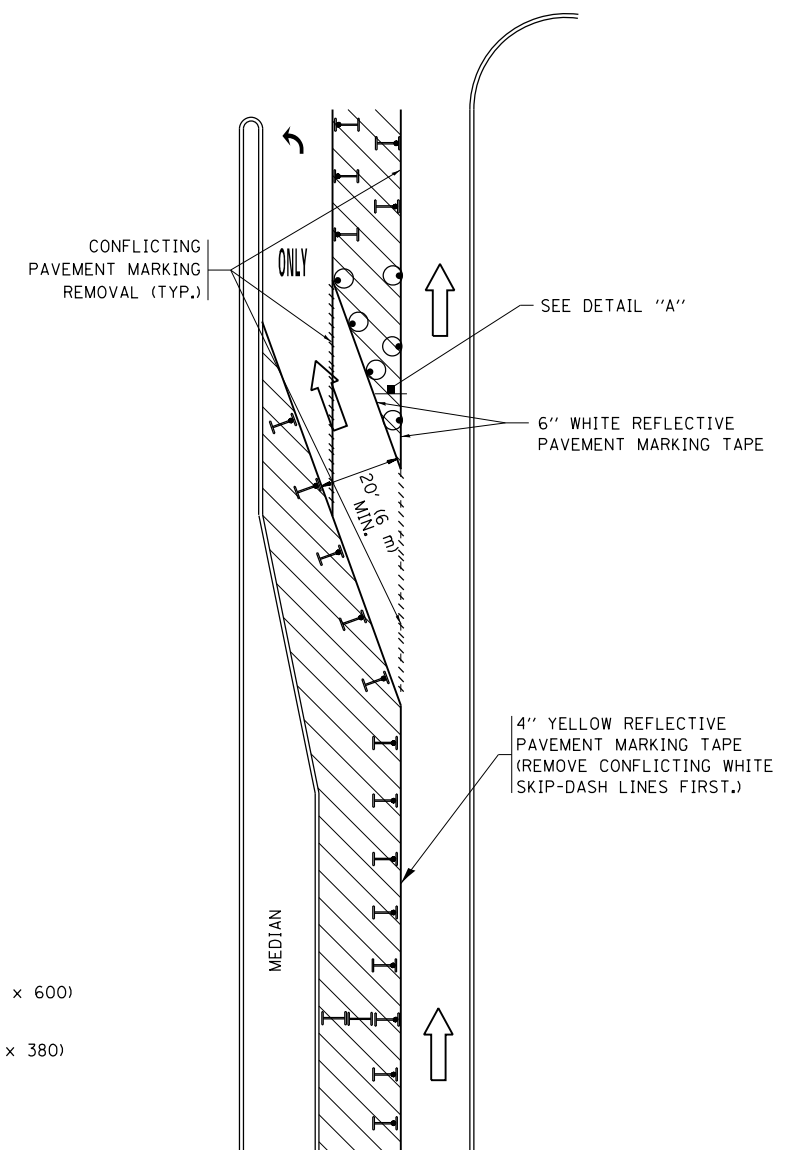
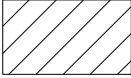







FIGURE 2

LEGEND

-  WORK AREA
-  LANE OPEN TO TRAFFIC
-  ARROW BOARD
-  TYPE I OR II BARRICADE OR DRUM WITH STEADY BURN LIGHT
-  DRUM WITH STEADY BURN LIGHT
-  SIGN ASSEMBLY
-  TYPE I OR II CHECK BARRICADE WITH FLASHING LIGHT

NOTES:

1. A) WHEN "L" IS \leq THE STORAGE LENGTH OF THE TURN LANE (AS SHOWN IN FIG. 1), USE FIGURE 1.
B) WHEN "L" IS $>$ THE STORAGE LENGTH OF THE TURN LANE OR THE TURN LANE IS WITHIN THE LANE CLOSURE, USE FIGURE 2.
2. CONES MAY BE SUBSTITUTED FOR BARRICADES OR DRUMS AT HALF THE SPACING DURING DAY OPERATIONS. CONES SHALL BE A MINIMUM OF 28 (710) IN HEIGHT.
3. LIGHTS WILL NOT BE REQUIRED ON BARRICADES OR DRUMS FOR DAY OPERATIONS. ALL LIGHTS SHALL BE MONODIRECTIONAL.
4. REFLECTIVE TEMPORARY PAVEMENT MARKINGS SHALL BE PLACED THROUGHOUT THE BARRICADED AREAS OF EACH TURN BAY AS SHOWN WHERE THE CLOSURE TIME IS GREATER THAN FOURTEEN (14) DAYS.
5. THIS APPLICATION ALSO APPLIES WHEN WORK IS BEING PERFORMED IN THE RIGHT LANE(S) AND THE RIGHT TURN BAY IS TO REMAIN OPEN. UNDER THIS CONDITION, "RIGHT TURN LANE" R3-1100R 24 x 24 (600 x 600) AND M6-2R 21 x 15 (530 x 380) SHALL BE USED.
6. THESE CONTROLS SHALL SUPPLEMENT MAINLINE TRAFFIC CONTROL FOR LANE CLOSURES.
7. THE SIGNS SHALL BE MOUNTED ABOVE THE BARRICADES/DRUMS ON SEPARATE SIGN SUPPORTS THAT MEET NCHRP 350 OR MASH PREQUIREMENTS.
8. TRAFFIC CONTROL AND PROTECTION AT TURN BAYS (TO REMAIN OPEN TO TRAFFIC) SHALL BE INCLUDED IN THE COST OF SPECIFIED TRAFFIC CONTROL STANDARDS OR ITEMS.

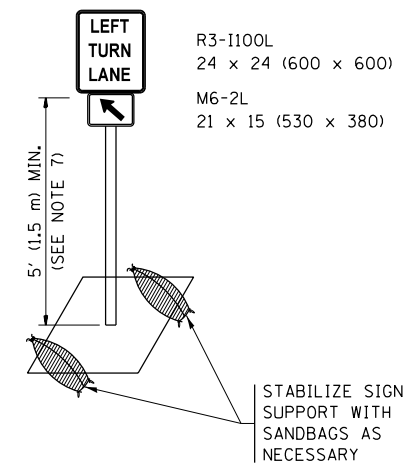

DETAIL A

All dimensions are in inches (millimeters) unless otherwise shown.

FILE NAME =	USER NAME = miduja	REVISED - T. RAMMACHER 09-08-94	REVISED - R. BORO 09-14-09	STATE OF ILLINOIS DEPARTMENT OF TRANSPORTATION	TRAFFIC CONTROL AND PROTECTION AT TURN BAYS (TO REMAIN OPEN TO TRAFFIC)	F.A. R.T.E.	SECTION	COUNTY	TOTAL SHEETS	SHEET NO.
pw:\planroom.dot.illinois.gov\PIDOT\Documents\IDOT Offices\District 1\Projects\0144815\REVISED Design\DI\HOUSEH\11-07-95	REVISED - A. HOUSEH 11-07-95	REVISED - A. SCHUETZE 07-01-13	REVISED - A. SCHUETZE 07-01-13			VAR.	2020-245-1	VARIOUS	21	20
Default	PLOT SCALE = 100.0000' / in.	REVISED - A. HOUSEH 10-12-96	REVISED - A. SCHUETZE 09-15-16			TC-14		CONTRACT NO. 62N15		
	PLOT DATE = 10/21/2020	REVISED - T. RAMMACHER 01-06-00	REVISED -			SCALE: NONE		SHEET 1 OF 1 SHEETS		STA. TO STA.

PARTIAL RAMP CLOSURE DETAILS

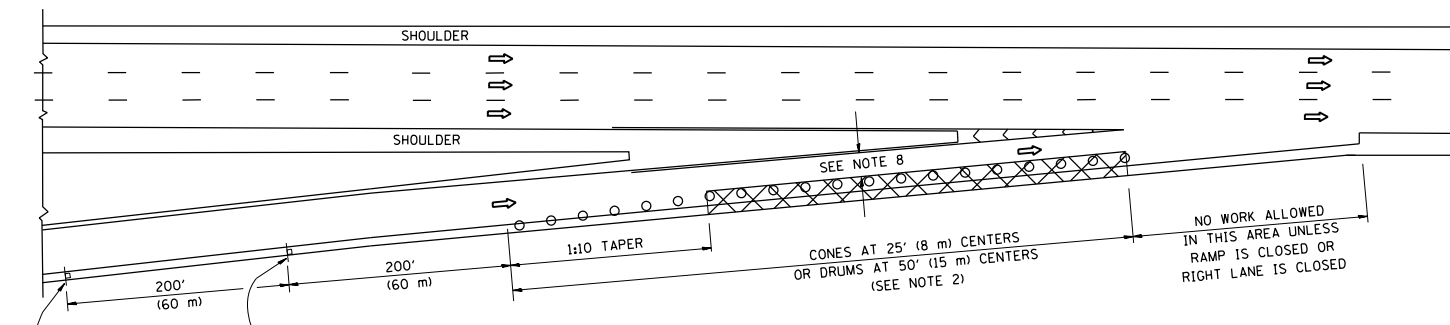

TYPICAL ENTRANCE RAMP

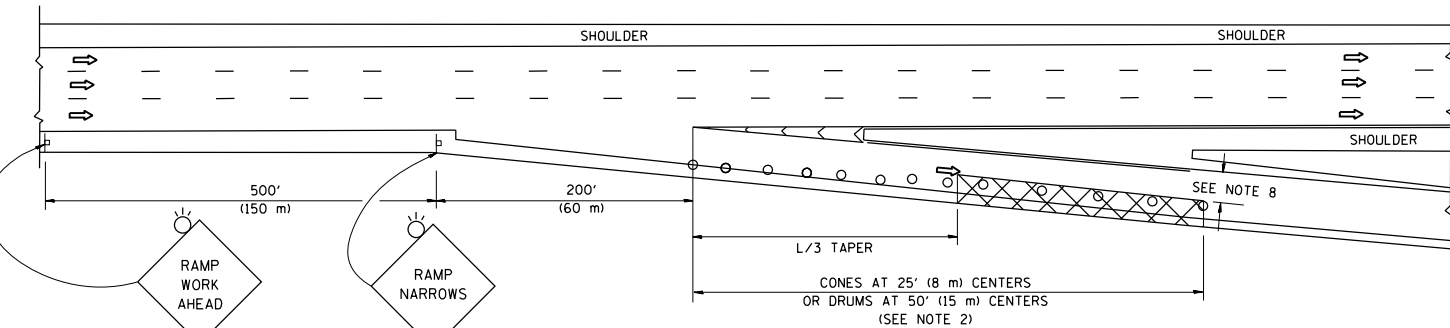

TYPICAL EXIT RAMP

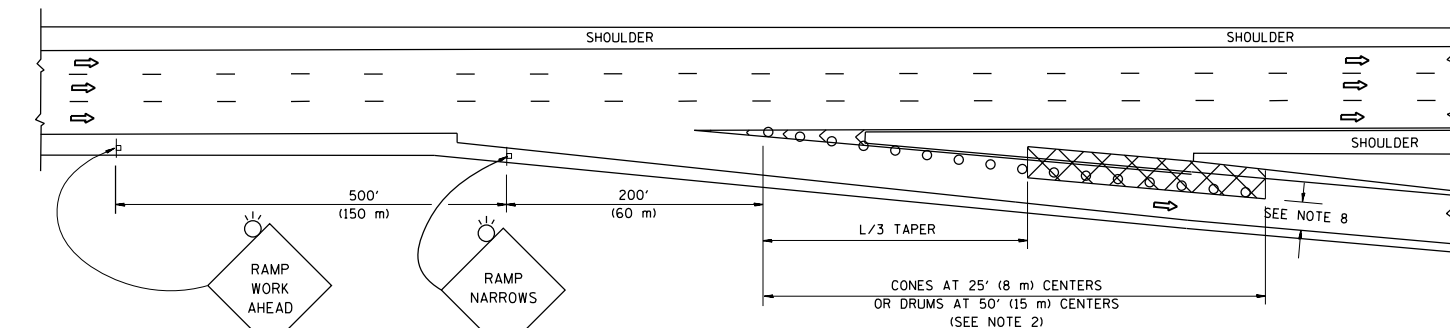

TYPICAL EXIT RAMP

SYMBOLS

- ACTIVE WORK AREA
- SIGN ON PORTABLE OR PERMANENT SUPPORT
- FLAGGER WITH CONTROL SIGN
- TYPE II BARRICADE OR DRUM
- CONE, DRUM OR BARRICADE
- IMPACT ATTENUATOR OF TYPE AND TEST LEVEL SPECIFIED

GENERAL NOTES

1. THE "L" DISTANCE EQUALS:

SPEED LIMIT	FORMULAS
45 mph (80 km/h)	METRIC ENGLISH
OR GREATER:	$L=0.65(W)(S)$ $L=(W)(S)$

W = WIDTH OF OFFSET IN FEET (METERS)
 S = NORMAL POSTED SPEED MPH (KM/H)
2. TYPE II BARRICADES OR DRUMS ARE REQUIRED FOR ALL NIGHTTIME CLOSURES. TYPE II BARRICADES OR DRUMS WITH MONODIRECTIONAL STEADY BURN LIGHTS ARE REQUIRED FOR DELINEATING OBSTACLES, EXCAVATIONS, OR HAZARDS EXCEEDING 100 FT (30m) IN LENGTH AT NIGHT.
3. ALL SIGNS SHALL BE POST MOUNTED IF THE CLOSURE TIME EXCEEDS FOUR DAYS.
4. FLASHING LIGHTS SHALL BE USED DURING THE HOURS OF DARKNESS AND SHALL BE INSTALLED ABOVE THE FIRST TWO SETS OF SIGNS.

SHOULDER CLOSURE DETAILS

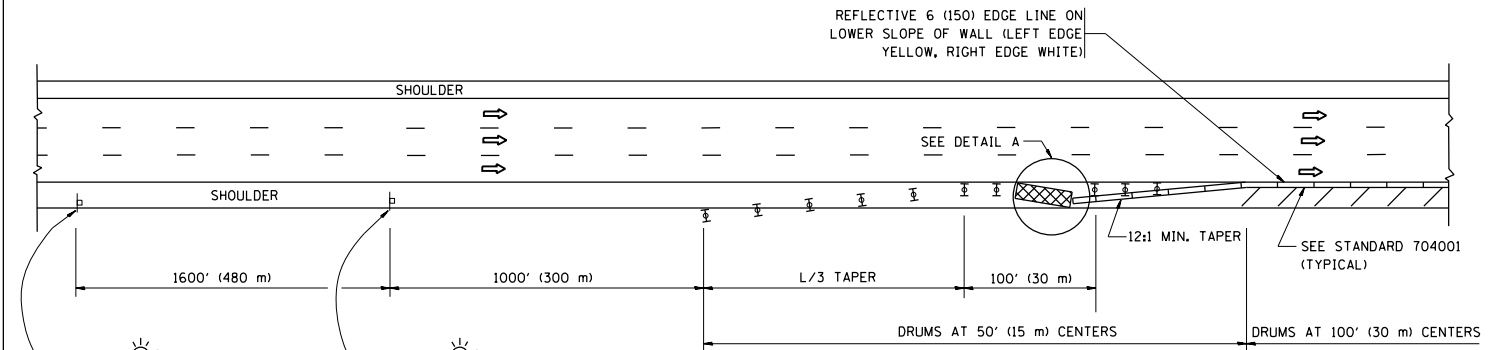

PERMANENT SHOULDER CLOSURE

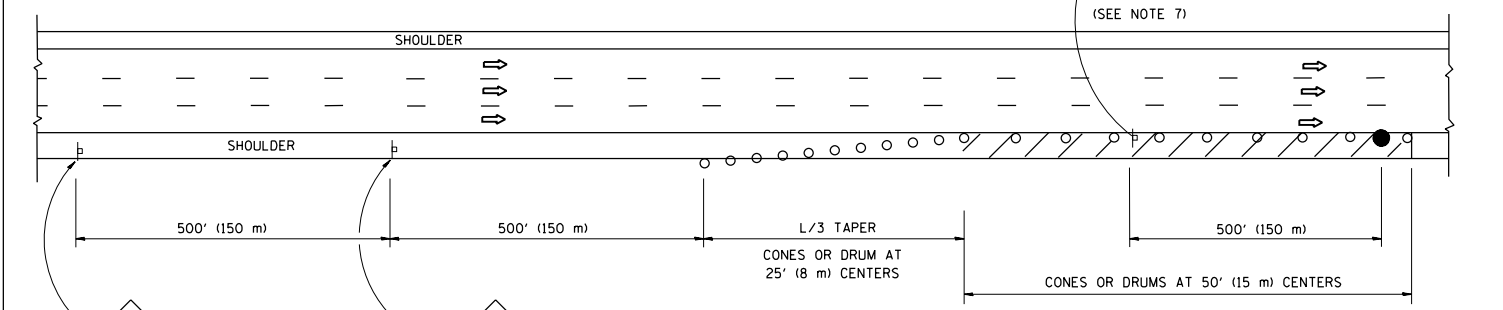

DAYTIME SHOULDER CLOSURE

THIS DETAIL IS USED WHERE:
 1. VEHICLES, EQUIPMENT, WORKERS OR THEIR ACTIVITIES ENCRANCH IN AN AREA CLOSER THAN 15' (4.5 m) TO THE EDGE OF PAVEMENT FOR A PERIOD IN EXCESS OF 15 MINUTES.

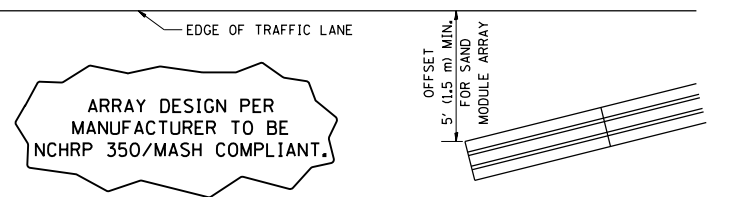

DETAIL "A"
 IMPACT ATTENUATOR, TEMPORARY
 (SEE NOTE 5)

5. THE IMPACT ATTENUATOR, TEMPORARY IS NOT REQUIRED WHEN THE TEMPORARY CONCRETE BARRIER WALL IS PROTECTED BY OR IS TIED INTO THE EXISTING GUARDRAIL. IF OFFSET IS LESS THAN 5 FEET USE NARROW USE TYPE DEVICE TO MEET NCHRP350/MASH.
6. AUTHORIZATION FROM THE DISTRICT'S BUREAU OF TRAFFIC IS REQUIRED FOR ALL FREEWAY CLOSURES.
7. THE FLAGGER AND FLAGGER SIGN ARE REQUIRED AT THE ABOVE WORK SITES WHEN:
 - a. FOUR OR MORE WORK VEHICLES ENTER THE TRAFFIC LANES IN A ONE HOUR PERIOD.
 - b. THE WORK ACTIVITY REQUIRES FREQUENT ENCROACHMENT INTO THE LANE OPEN TO TRAFFIC.
 THE FLAGGER SHALL BE STATIONED APPROXIMATELY 100' (30 m) TO 200' (60 m) IN ADVANCE OF THE WORKERS.
8. 12' MIN. WIDTH TANGENT SECTION
 16' MIN. WIDTH CURVE SECTION.

ALL DIMENSIONS ARE IN INCHES (MILLIMETERS) UNLESS OTHERWISE SHOWN.

FILE NAME =	USER NAME = midyja	DESIGNED -	REVISED - S.P.B. 01-07
pw:\planroom.dot.illinois.gov\PIWIDOT\Documents\IDOT Offices\District 1\Projects\0144815\Drawings\Design\0144815\Sheet\plan.dgn		DRAWN -	REVISED - S.P.B. 12-09
Default	PLOT SCALE = 100.0000' / 1"	CHECKED -	REVISED - M.D. 06-13
	PLOT DATE = 10/21/2020	DATE -	REVISED - M.D. 01-18

STATE OF ILLINOIS
 DEPARTMENT OF TRANSPORTATION

TRAFFIC CONTROL DETAILS FOR FREEWAY
 SHOULDER CLOSURES AND PARTIAL RAMP CLOSURES

SCALE: NONE SHEET 1 OF 1 SHEETS STA. TO STA.

F.A. RTE.	SECTION	COUNTY	TOTAL SHEETS	SHEET NO.
VAR.	2020-245-1	VARIOUS	21	21
TC-17		CONTRACT NO. 62N15		
ILLINOIS FED. AID PROJECT				