

STATE OF ILLINOIS DEPARTMENT OF TRANSPORTATION

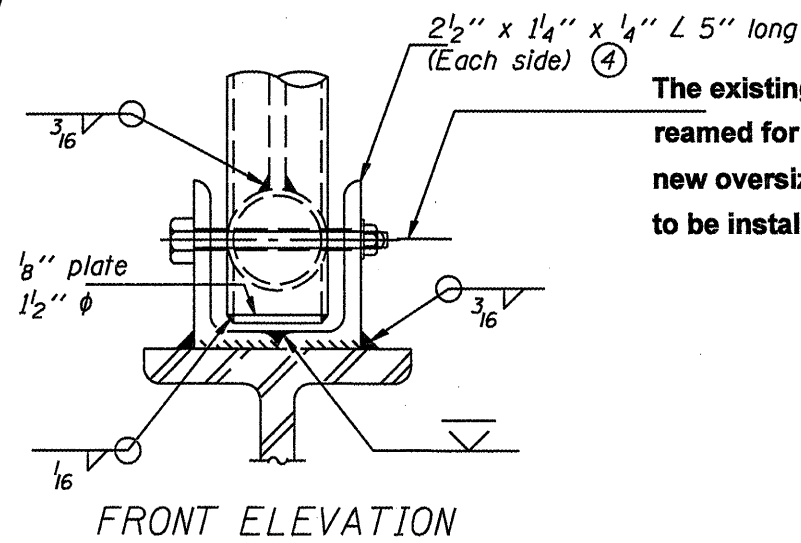

Details not shown same as "ELEVATION" at right.

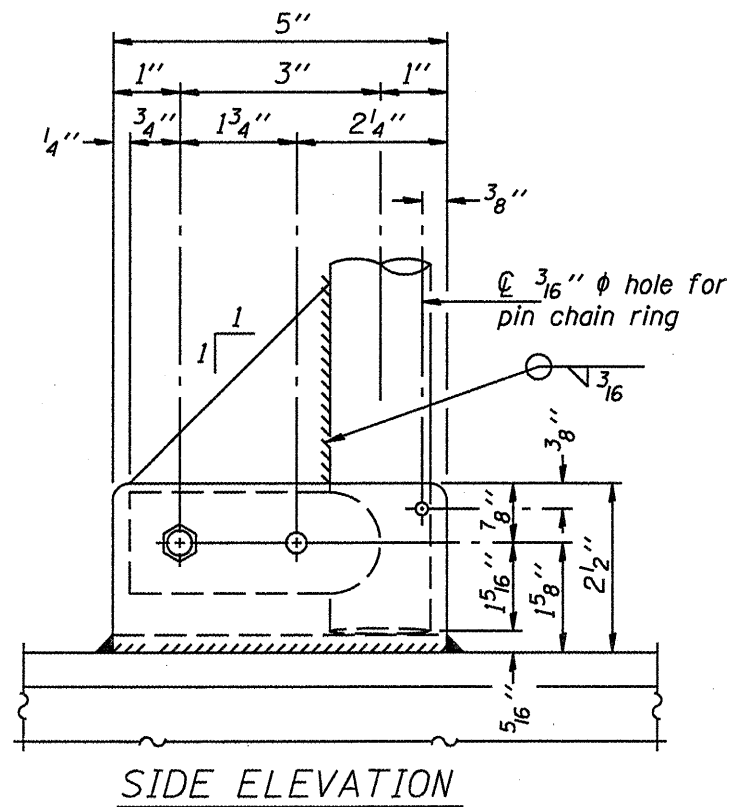
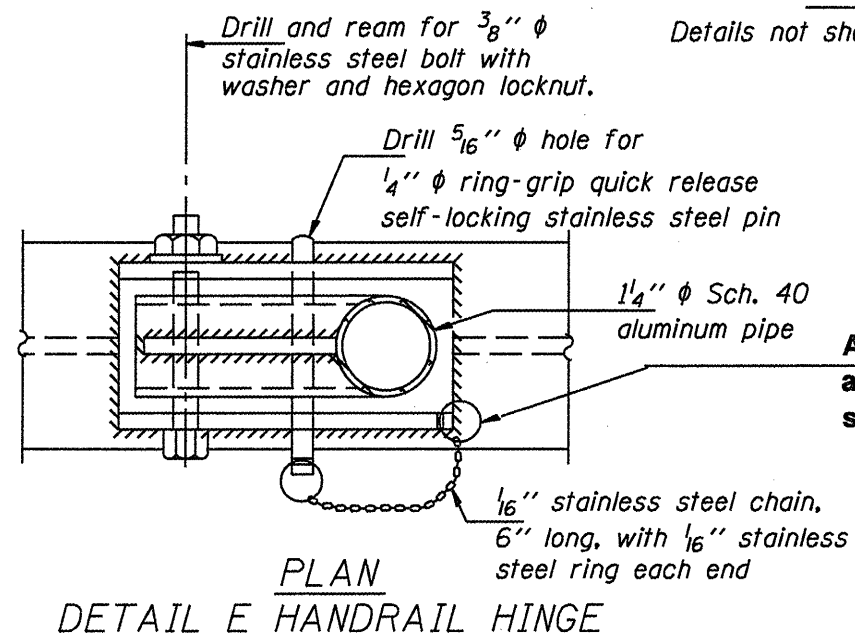

A new stainless steel chain shall be attached to the angle with a 1/16" stainless steel ring.

OVERHEAD SIGN STRUCTURES
 HANDRAIL HINGE REPAIR DETAIL