

01-17-2020 LETTING ITEM 080

STATE OF ILLINOIS
DEPARTMENT OF TRANSPORTATION

F.A. RTE	SECTION	COUNTY	TOTAL SHEETS	SHEET NO
VAR			45	1
ILLINOIS		CONTRACT NO. 46534		
DEWITT, MCLEAN, PIATT ** D-5HT PVMNT MRK RPR 20-22				

D-5

M-60-015-20

FOR INDEX OF SHEETS, SEE SHEET NO. 2
FOR SUMMARY OF QUANTITIES, SEE SHEET NO. 10-11

PROPOSED HIGHWAY PLANS

VARIOUS ROUTES
SECTION D-5HT PVMNT MRK RPR 20-22
PROJECT
PAVEMENT MARKING
VARIOUS COUNTIES

M-60-015-20

FULL SIZE PLANS HAVE BEEN PREPARED USING STANDARD
ENGINEERING SCALES. REDUCED SIZED PLANS WILL NOT
CONFORM TO STANDARD SCALES. IN MAKING MEASUREMENTS
ON REDUCED PLANS, THE ABOVE SCALES MAY BE USED.

J.U.L.I.E.
JOINT UTILITY LOCATION INFORMATION FOR EXCAVATORS
1-800-892-0123
OR 811

DEWITT COUNTY: SANTA ANNA TOWNSHIP, HARP TOWNSHIP, CLINTONIA TOWNSHIP,
WAPELLA TOWNSHIP

MCLEAN COUNTY: BELLFLOWER TOWNSHIP, EMPIRE TOWNSHIP, RANDOLPH TOWNSHIP,
MOUNT HOPE TOWNSHIP, BLOOMINGTON TOWNSHIP, OLD TOWN TOWNSHIP,
CROPSY TOWNSHIP, NORMAL TOWNSHIP, LEXINGTON TOWNSHIP, YATES TOWNSHIP,
HUDSON TOWNSHIP, DANVERS TOWNSHIP, DALE TOWNSHIP, DRY GROVE TOWNSHIP,

PIATT COUNTY: UNITY TOWNSHIP, CERRO GOROD TOWNSHIP, WILLOW BRANCH TOWNSHIP,
BEMENT TOWNSHIP, MONTICELLO TOWNSHIP, SANGAMON TOWNSHIP



FOR LOCATION MAPS SEE SHEETS 5, 6, 7, 8, & 9

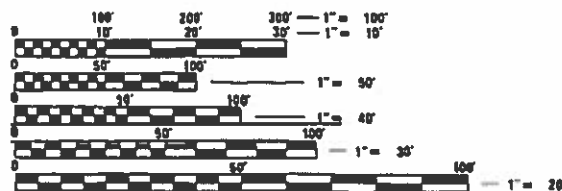

PROJECT ENGINEER: JASON STULTS
PROJECT MANAGER: RYAN CARROLL
DESIGNER: AARON FARNHAM
PHONE NUMBER: (217) 465-4181
CONTRACT NO. 46534

STATE OF ILLINOIS
DEPARTMENT OF TRANSPORTATION

SUBMITTED 10/10 2019
Kensita G. [Signature]
REGIONAL ENGINEER

Dec 6 2019
[Signature]
ENGINEER OF DESIGN AND ENVIRONMENT

Dec 6 2019
Paul P. [Signature]
DIRECTOR OF HIGHWAYS PROJECT IMPLEMENTATION

PRINTED BY THE AUTHORITY
OF THE STATE OF ILLINOIS

INDEX OF SHEETS

SHEET NO.	DESCRIPTION
1	COVER SHEET
2	INDEX OF SHEETS
2	LIST OF HIGHWAY STANDARDS
2	COMMITMENTS
3-4	GENERAL NOTES
5-9	LOCATION MAPS
10-11	SUMMARY OF QUANTITIES
12-40	SCHEDULE OF QUANTITIES
41-45	DETAILS

HIGHWAY STANDARDS

STANDARD NO.	DESCRIPTION
000001-07	STANDARD SYMBOLS, ABBREVIATIONS, AND PATTERNS
001006	DECIMAL OF AN INCH AND OF A FOOT
701301-04	LANE CLOSURE, 2L, 2W, SHORT TIME OPERATIONS
701311-03	LANE CLOSURE, 2L, 2W, MOVING OPERATIONS - DAY ONLY
701422-10	LANE CLOSURE, MULTILANE, FOR SPEEDS ≥ 45 MPH TO 55 MPH
701426-09	LANE CLOSURE, MULTILANE, INTERMITTENT OR MOVING OPERATION, FOR SPEEDS ≥ 45 MPH
701427-05	LANE CLOSURE, MULTILANE, INTERMITTENT OR MOVING OPERATION, FOR SPEEDS ≤ 45 MPH
701501-06	LANE CLOSURE, URBAN, 2L, 2W, UNDIVIDED
701502-09	LANE CLOSURE, URBAN, 2L, 2W, WITH BIDIRECTIONAL LEFT TURN LANE
701601-09	LANE CLOSURE, URBAN, MULTILANE, 1W OR 2W WITH NONTRANSVERSIBLE MEDIAN
701602-10	LANE CLOSURE, URBAN, MULTILANE, 2W WITH BIDIRECTIONAL LEFT TURN LANE
701701-10	URBAN LANE CLOSURE, MULTILANE INTERSECTION
701901-08	TRAFFIC CONTROL DEVICES
780001-05	TYPICAL PAVEMENT MARKINGS

COMMITMENTS

NO COMMITMENTS

MODEL: I:\MODEL\NAMES
 FILE: Names_Plan\Illum\comadad\illinois.gov\RWIDOT\Documents\DOT_Offices\Ibirtct_5\Project\IDS46534\CADDData\CAD\Sheet\IDS46534\ch1\index.dgn

* DEWITT, MCLEAN, PIATT ** D-SHT PVMNT MRK RPR 20-22

USER NAME = farnhamba PLOT SCALE = 40.0000 ' / in. PLOT DATE = 10/15/2019	DESIGNED - DRAWN - CHECKED - DATE -	REVISED - REVISED - REVISED - REVISED -	STATE OF ILLINOIS DEPARTMENT OF TRANSPORTATION	INDEX OF SHEETS, HIGHWAY STANDARDS, GENERAL NOTES, & COMMITMENTS	F.A. RTE. VAR	SECTION **	COUNTY -	TOTAL SHEETS 45	SHEET NO. 2
SCALE:				SHEET 1 OF 3 SHEETS	STA. TO STA.		CONTRACT NO. 46534		
							ILLINOIS	FED. AID PROJECT	

GENERAL NOTES

G.N.-100A
ELECTRONIC FILES AND/OR ELECTRONIC SURVEY INFORMATION INCLUDING CADD FILES WILL NOT BE AVAILABLE TO THE CONTRACTOR.

G.N.-107.12

MCLEAN COUNTY
LOCATION #14

THE NAME, ADDRESS AND TELEPHONE NUMBER OF THE LOCAL RAILROAD CONTACT IS:

Mr. Eric Webb
General Manager
Bloomer Line
P.O. Box 546
Gibson City, IL 60936
217-784-4923

SPECIAL ATTENTION IS CALLED TO ARTICLE 107.12 REGARDING RAILROAD FLAGGERS. THE NAME, ADDRESS AND TELEPHONE NUMBER OF THE RAILROAD CONTACT PERSON FOR FLAGGERS IS:

Mr. Eric Webb
General Manager
Bloomer Line
P.O. Box 546
Gibson City, IL 60936
217-784-4923

Some railroads require contractors to obtain a Right Of Entry Permit before entering upon railroad right of way. It is the responsibility of the Contractor to obtain a Railroad Right of Entry permit from the railroad if required by the railroad(s).

G.N.-107.12

PIATT COUNTY
LOCATION #1

THE NAME, ADDRESS AND TELEPHONE NUMBER OF THE LOCAL RAILROAD CONTACT IS:

Mr. Cody Mcgee
Roadmaster
Decatur & Eastern Illinois Railroad
307 N Central St.
Paris, IL 61944
217-855-4107

SPECIAL ATTENTION IS CALLED TO ARTICLE 107.12 REGARDING RAILROAD FLAGGERS. THE NAME, ADDRESS AND TELEPHONE NUMBER OF THE RAILROAD CONTACT PERSON FOR FLAGGERS IS:

Mr. Cody Mcgee
Roadmaster
Decatur & Eastern Illinois Railroad
307 N Central St.
Paris, IL 61944
217-855-4107

G.N.-107.12

PIATT COUNTY
LOCATION \$4

THE NAME, ADDRESS AND TELEPHONE NUMBER OF THE LOCAL RAILROAD CONTACT IS:

Mr. Johnny Declue
Roadmaster
Decatur Central Railroad
815-343-3977

SPECIAL ATTENTION IS CALLED TO ARTICLE 107.12 REGARDING RAILROAD FLAGGERS. THE NAME, ADDRESS AND TELEPHONE NUMBER OF THE RAILROAD CONTACT PERSON FOR FLAGGERS IS:

Mr. Johnny Declue
Roadmaster
Decatur Central Railroad
815-343-3977

MODEL: I:\MODEL\MHFS
FILE: MHFS_Plan\p14mcomadad\illinois.gov\PIATT\DOT\Documents\DOT_Offices\PIATT.ctb 5:Project\DOT\DOT\CADDData\CADD\Sheet\0546534.ctb\p14mcomadad.dgn

* DEWITT, MCLEAN, PIATT ** D-SHT PVMNT MRK RPR 20-22

	USER NAME = farnhamba	DESIGNED -	REVISED -	STATE OF ILLINOIS DEPARTMENT OF TRANSPORTATION	INDEX OF SHEETS, HIGHWAY STANDARDS, GENERAL NOTES, & COMMITMENTS	F.A. RTE.	SECTION	COUNTY	TOTAL SHEETS	SHEET NO.	
		DRAWN -	REVISED -			VAR	**	-	45	3	
	PLOT SCALE = 40.0000 ' / in.	CHECKED -	REVISED -			CONTRACT NO. 46534					
	PLOT DATE = 10/15/2019	DATE -	REVISED -			SCALE:	SHEET 2	OF 3	SHEETS	STA.	TO STA.

GENERAL NOTES

G.N.-107.12

DEWITT COUNTY
LOCATION #4
MCLEAN COUNTY
LOCATION #2

THE NAME, ADDRESS AND TELEPHONE NUMBER OF THE LOCAL RAILROAD CONTACT IS:

Mr. Paul Chojenski
Manager, Public Projects CN
CN Railroad
17641 South Ashland Avenue
Homewood, IL 60430
(708) 332-3557

SPECIAL ATTENTION IS CALLED TO ARTICLE 107.12 REGARDING RAILROAD FLAGGERS. THE NAME, ADDRESS AND TELEPHONE NUMBER OF THE RAILROAD CONTACT PERSON FOR FLAGGERS IS:

Mr. Paul Chojenski
Manager, Public Projects CN
CN Railroad
17641 South Ashland Avenue
Homewood, IL 60430
(708) 332-3557

Some railroads require contractors to obtain a Right Of Entry Permit before entering upon railroad right of way. It is the responsibility of the Contractor to obtain a Railroad Right of Entry permit from the railroad if required by the railroad(s).

G.N.-107.12

MCLEAN COUNTY
LOCATION #1
DEWITT COUNTY
LOCATION #3, #7, #10

THE NAME, ADDRESS AND TELEPHONE NUMBER OF THE LOCAL RAILROAD CONTACT IS:

Mr. Scott Overbey
Engineer of Public Improvements
Norfolk Southern Railway Company
1200 Peachtree St., NE
Atlanta, GA 30309
(404) 582-5588

SPECIAL ATTENTION IS CALLED TO ARTICLE 107.12 REGARDING RAILROAD FLAGGERS. THE NAME, ADDRESS AND TELEPHONE NUMBER OF THE RAILROAD CONTACT PERSON FOR FLAGGERS IS:

Flagging will be assigned by Norfolk Southern once their Right of Entry and Insurance requirements have been met

Some railroads require contractors to obtain a Right Of Entry Permit before entering upon railroad right of way. It is the responsibility of the Contractor to obtain a Railroad Right of Entry permit from the railroad if required by the railroad(s).

G.N.-107.12

MCLEAN COUNTY
LOCATION #19

THE NAME, ADDRESS AND TELEPHONE NUMBER OF THE LOCAL RAILROAD CONTACT IS:

Mr. Josh Thomas
Roadmaster
Toledo, Peoria and Western Railway
1990 East Washington Street
East Peoria, IL 61611
(309) 303-9404

SPECIAL ATTENTION IS CALLED TO ARTICLE 107.12 REGARDING RAILROAD FLAGGERS. THE NAME, ADDRESS AND TELEPHONE NUMBER OF THE RAILROAD CONTACT PERSON FOR FLAGGERS IS:

Mr. Josh Thomas
Roadmaster
Toledo, Peoria and Western Railway
1990 East Washington Street
East Peoria, IL 61611
(309) 303-9404

MODEL: I:\MODEL\NAMES
FILE: Names_Plan\p19m\comada.dwg
PROJECT: I:\Projects\10546534\CADDData\CADD\Sheet\10546534\p19m\ch19notes.dgn

USER NAME = farnhamba	DESIGNED -	REVISED -
	DRAWN -	REVISED -
PLOT SCALE = 40.0000 ' / in.	CHECKED -	REVISED -
PLOT DATE = 10/15/2019	DATE -	REVISED -

**STATE OF ILLINOIS
DEPARTMENT OF TRANSPORTATION**

**INDEX OF SHEETS, HIGHWAY STANDARDS,
GENERAL NOTES, & COMMITMENTS**

SCALE: SHEET 3 OF 3 SHEETS STA. TO STA.

* DEWITT, MCLEAN, PIATT ** D-SHT PVMNT MRK RPR 20-22

F.A. RTE.	SECTION	COUNTY	TOTAL SHEETS	SHEET NO.
VAR	**	-	45	4
			CONTRACT NO. 46534	
		ILLINOIS	FED. AID PROJECT	

DEWITT COUNTY

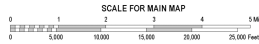
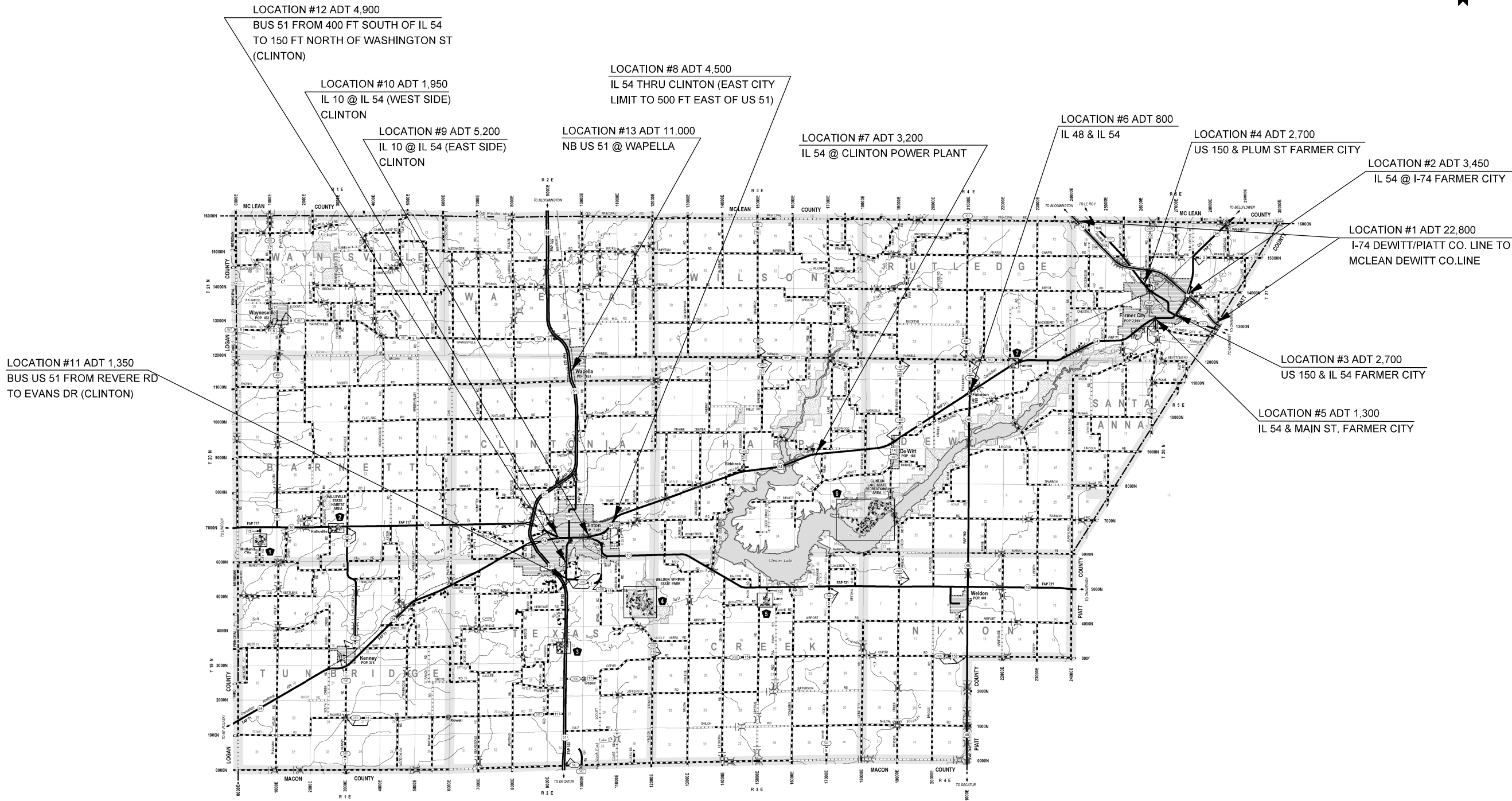

MODEL: s:\MODEL\MAPS
 FILE: maps\pva\pva\mcomad\data\links\gov\PIW\DOT\Documents\DOT_Offices\Dir\dtc_5\Projects\DS46534\CADD\data\Design\Backups\DS46534-1-1-LocationMap.dgn

USER NAME = farnhamba	DESIGNED -	REVISED -
	DRAWN -	REVISED -
PLOT SCALE = 40,0000 ' / in.	CHECKED -	REVISED -
PLOT DATE = 10/15/2019	DATE -	REVISED -

**STATE OF ILLINOIS
DEPARTMENT OF TRANSPORTATION**

SCALE: SHEET 1 OF 5 SHEETS STA. TO STA.

**DEWITT COUNTY
LOCATION MAP**

* DEWITT, MCLEAN, PIATT ** D-5HT PVMNT MRK RPR 20-22

F.A. RTE.	SECTION	COUNTY	TOTAL SHEETS	SHEET NO.
VAR	**	VARIOUS	45	5
CONTRACT NO. 46534				
		ILLINOIS	FED. AID PROJECT	

MCLEAN COUNTY

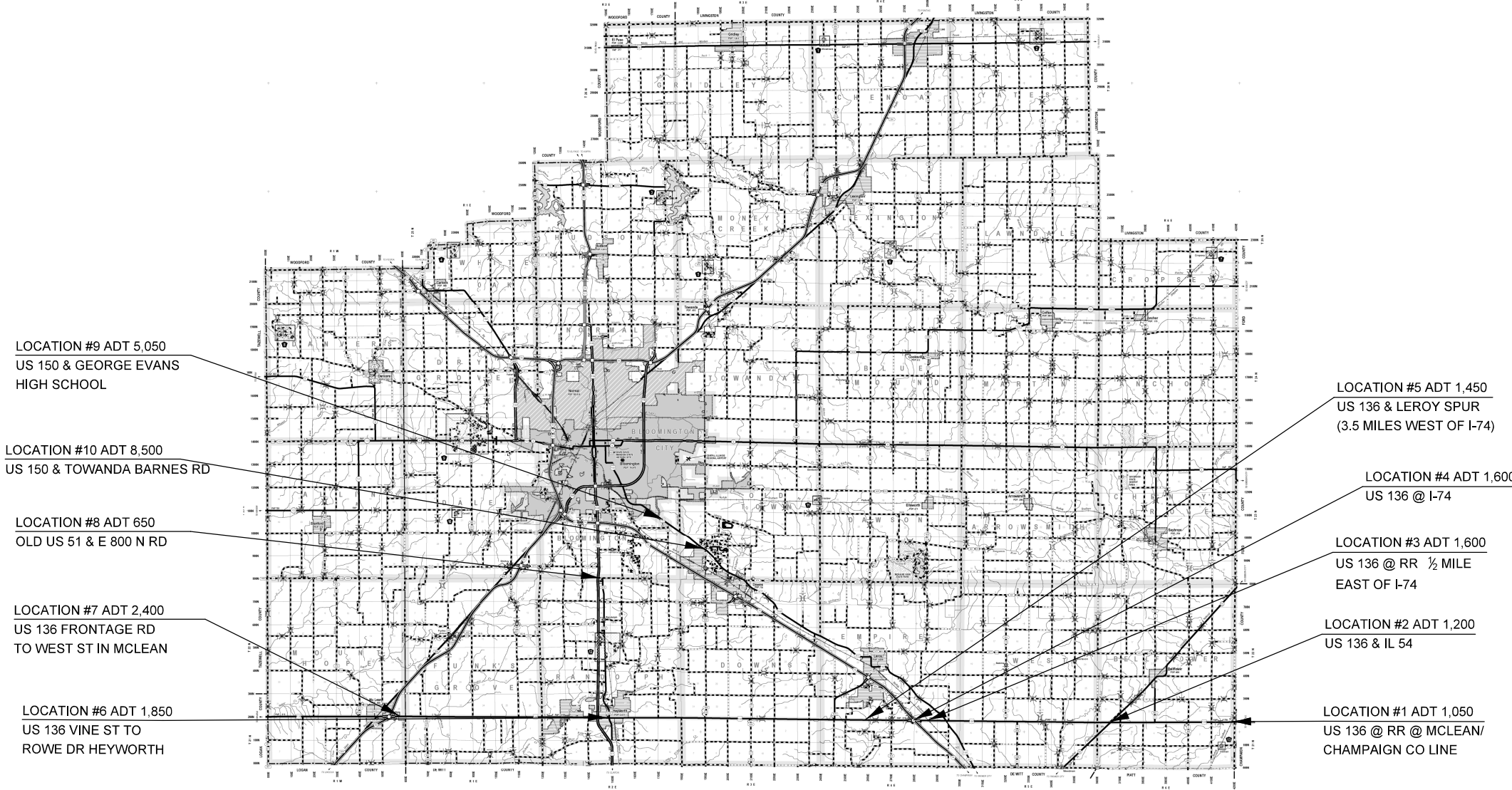

LOCATION #9 ADT 5,050
US 150 & GEORGE EVANS
HIGH SCHOOL

LOCATION #10 ADT 8,500
US 150 & TOWANDA BARNES RD

LOCATION #8 ADT 650
OLD US 51 & E 800 N RD

LOCATION #7 ADT 2,400
US 136 FRONTAGE RD
TO WEST ST IN MCLEAN

LOCATION #6 ADT 1,850
US 136 VINE ST TO
ROWE DR HEYWORTH

LOCATION #5 ADT 1,450
US 136 & LEROY SPUR
(3.5 MILES WEST OF I-74)

LOCATION #4 ADT 1,600
US 136 @ I-74

LOCATION #3 ADT 1,600
US 136 @ RR ½ MILE
EAST OF I-74

LOCATION #2 ADT 1,200
US 136 & IL 54

LOCATION #1 ADT 1,050
US 136 @ RR @ MCLEAN/
CHAMPAIGN CO LINE



MODEL: s:\MODEL\MAPS
FILE: Maps: p:\pub\mcom\data\illinois\pww\DOT\Documents\DOT_Offices\District 5\Projects\0546534\CADD\Design\Backups\0546534-1-1-LocationMap.dgn

USER NAME = farnhamba	DESIGNED -	REVISED -
	DRAWN -	REVISED -
PLOT SCALE = 40,0000 ' / in.	CHECKED -	REVISED -
PLOT DATE = 10/15/2019	DATE -	REVISED -

**STATE OF ILLINOIS
DEPARTMENT OF TRANSPORTATION**

MCLEAN COUNTY LOCATION MAP	
SCALE:	SHEET 2 OF 5 SHEETS STA. TO STA.

* DEWITT, MCLEAN, PIATT ** D-5HT PVMNT MRK RPR 20-22				
F.A. RTE.	SECTION	COUNTY	TOTAL SHEETS	SHEET NO.
VAR	**	-	45	6
CONTRACT NO. 46534				
ILLINOIS FED. AID PROJECT				

MCLEAN COUNTY

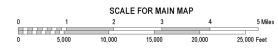
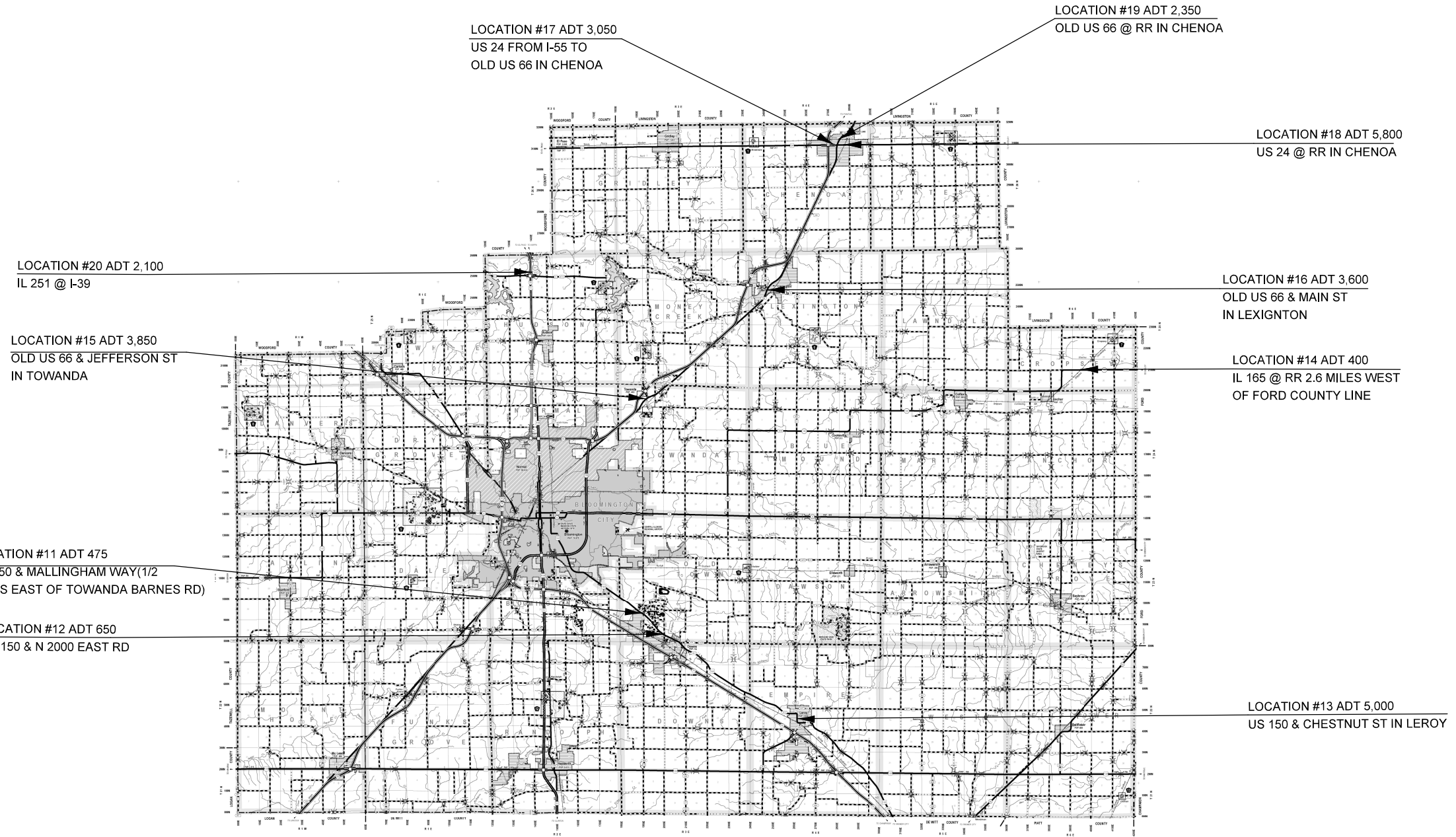

MODEL: \\MODEL\MAPS
 FILE: \\maps_p\pub\mcom\m_data\illinois\pww\DOT\Documents\DOT_Offices\Dir\dtc_3\Projects\DS46534\CADD\Map\Design\Backups\DS46534-1-1-LocationMap.dgn

USER NAME = farnhamba	DESIGNED -	REVISED -
	DRAWN -	REVISED -
PLOT SCALE = 40,0000 ' / in.	CHECKED -	REVISED -
PLOT DATE = 10/15/2019	DATE -	REVISED -

**STATE OF ILLINOIS
DEPARTMENT OF TRANSPORTATION**

MCLEAN COUNTY LOCATION MAP			
SCALE:	SHEET 3	OF 5 SHEETS	STA. TO STA.

* DEWITT, MCLEAN, PIATT ** D-SHT PVMNT MRK RPR 20-22				
F.A. RTE.	SECTION	COUNTY	TOTAL SHEETS	SHEET NO.
VAR	**	-	45	7
CONTRACT NO. 46534				
ILLINOIS FED. AID PROJECT				

MCLEAN COUNTY



LOCATION #26 ADT 3,800
BUS US 51 FROM RAAB
RD TO I-39

LOCATION #25 ADT 1,450
NB & SB BUS US 51 FROM
WOODRIG RD TO RAAB RD

LOCATION #24 ADT 3,200
US 150 MITSUBISHI
MOTORWAY FROM IL 9
TO I-74

LOCATION #23 ADT 4,600
IL 9 & FOX HILLS DR
(WEST OF BLOOMINGTON)

LOCATION #21 ADT 2,500
IL 9 & IL 122

LOCATION #22 ADT 4,600
IL 9 & COVELL RD
(WEST OF BLOOMINGTON)

LOCATION #27 ADT 2,400
US 150/IL 9 FROM TRUCKERS
LANE TO WALTON DRIVE

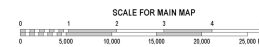
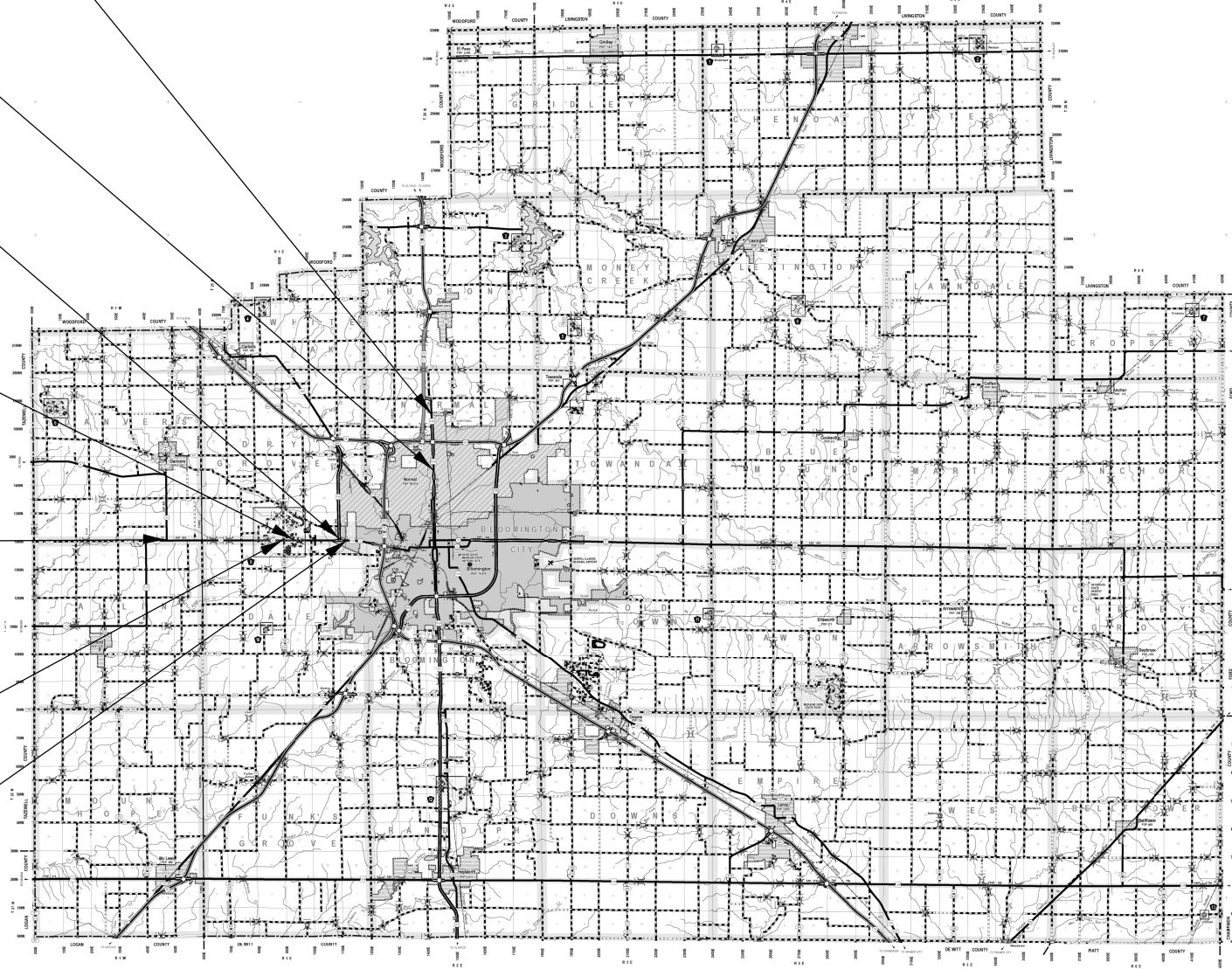

MODEL: \\MODEL\MAPS
 FILE: Maps: p:\blm\comada.dwg\Illinois\pwr\WIDDOT\Documents\DOT_Offices\District 5\Projects\0546534\CADD\Drawn\Backups\0546534-sh1-LocationMap.dwg

USER NAME = farnhamba	DESIGNED -	REVISED -
PLOT SCALE = 40,0000 ' / in.	DRAWN -	REVISED -
PLOT DATE = 10/15/2019	CHECKED -	REVISED -
	DATE -	REVISED -

**STATE OF ILLINOIS
DEPARTMENT OF TRANSPORTATION**

SCALE: SHEET 4 OF 5 SHEETS STA. TO STA.

**MCLEAN COUNTY
LOCATION MAP**

* DEWITT, MCLEAN, PIATT ** D-SHT PVMNT MRK RPR 20-22

F.A. RTE.	SECTION	COUNTY	TOTAL SHEETS	SHEET NO.
VAR	**	-	45	8
CONTRACT NO. 46534				
ILLINOIS FED. AID PROJECT				

PIATT COUNTY

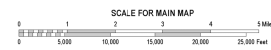
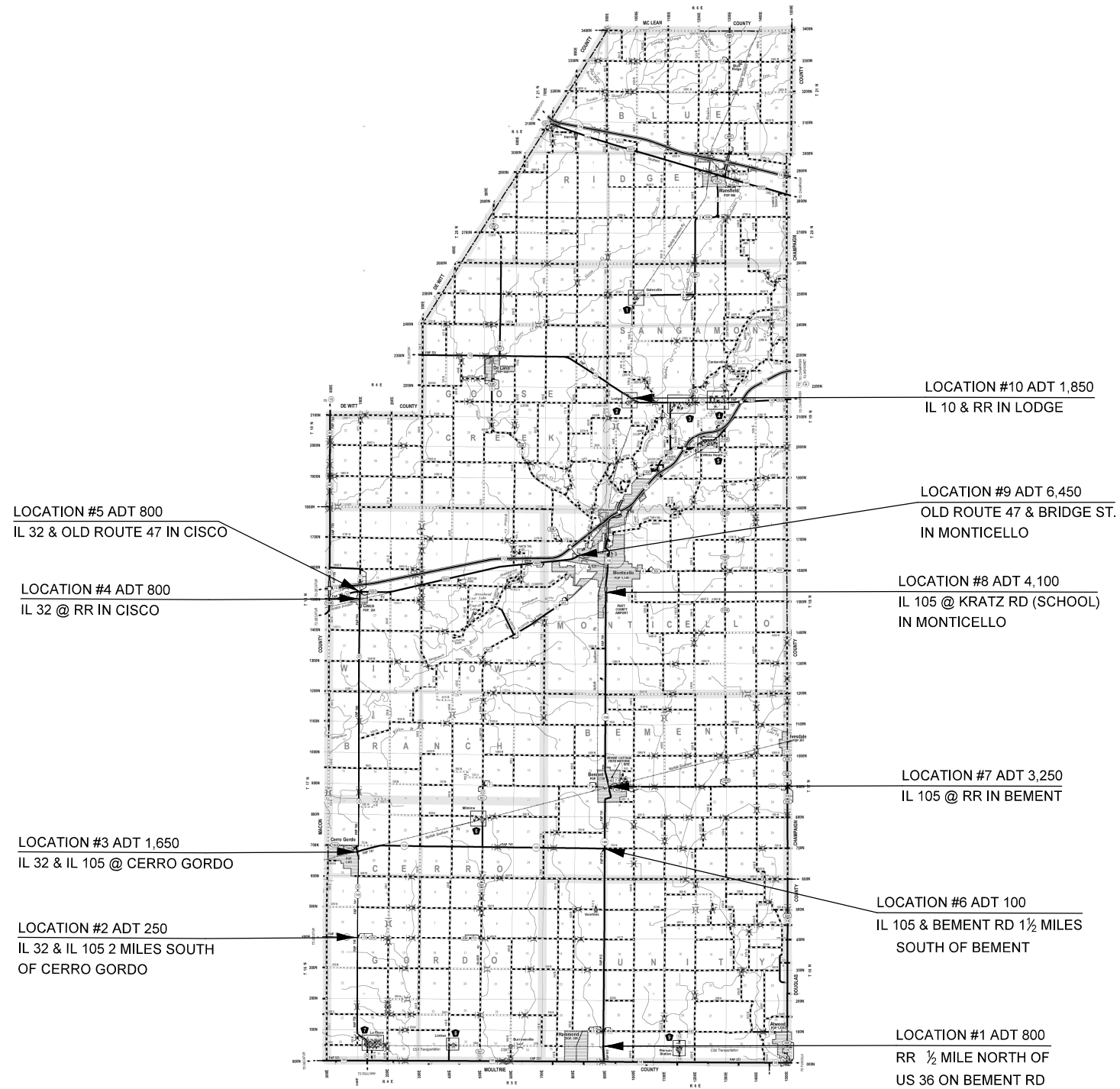

MODEL: s:\MODEL\MAPS
FILE: Maps: piatt\mainsheet.dwg
PROJECT: D:\Projects\46534\CADD\Map\Design\Backups\46534-1-1-LocationMap.dwg

USER NAME = farnhamba	DESIGNED -	REVISED -
	DRAWN -	REVISED -
PLOT SCALE = 40,0000 ' / in.	CHECKED -	REVISED -
PLOT DATE = 10/15/2019	DATE -	REVISED -

STATE OF ILLINOIS
DEPARTMENT OF TRANSPORTATION

PIATT COUNTY LOCATION MAP	
SCALE:	SHEET 5 OF 5 SHEETS STA. TO STA.

* DEWITT, MCLEAN, PIATT ** D-SHT PVMNT MRK RPR 20-22				
F.A. RTE.	SECTION	COUNTY	TOTAL SHEETS	SHEET NO.
VAR	**	-	45	9
CONTRACT NO. 46534				
ILLINOIS FED. AID PROJECT				

SUMMARY OF QUANTITIES

LOCATION OF WORK:	VARIOUS	VARIOUS	VARIOUS	VARIOUS	VARIOUS	VARIOUS
	DEWITT	DEWITT	MCLEAN	MCLEAN	PIATT	PIATT
VARIOUS COUNTIES	LOCATIONS:	LOCATIONS:	LOCATIONS:	LOCATIONS:	LOCATIONS:	LOCATIONS:
	8, 9, 10, 11, 12, 13	1, 2, 3, 4, 5, 6, 7	8, 9, 10, 11, 12, 15, 22, 23, 24, 25, 26, 27	1,2,3 4,5,6,7,13,14, 16,17,18,19,20,21,24	8, 9	1, 2, 3, 4, 5, 6, 7, 10
FUNDING BREAKOUT:	100% STATE	100% STATE	100% STATE	100% STATE	100% STATE	100% STATE
	URBAN	RURAL	URBAN	RURAL	URBAN	RURAL
CONSTRUCTION TYPE CODE:	0021	0021	0021	0021	0021	0021

CODE	ITEM	UNIT	TOTAL QUANTITY	QUANTITY	QUANTITY	QUANTITY	QUANTITY	QUANTITY	QUANTITY
78000100	THERMOPLASTIC PAVEMENT MARKING - LETTERS AND SYMBOLS	SQ FT	12,746.20	2,464.80	358.20	6,774.28	2,534.52	15.60	598.80
78000200	THERMOPLASTIC PAVEMENT MARKING - LINE 4"	FOOT	331,500.00	41,750.00	26,150.00	170,940.00	73,025.00	1,535.00	18,100.00
78000400	THERMOPLASTIC PAVEMENT MARKING - LINE 6"	FOOT	7,975.00	150.00	790.00	4,014.50	2,475.50	165.00	380.00
78000500	THERMOPLASTIC PAVEMENT MARKING - LINE 8"	FOOT	120.00	120.00	0.00	0.00	0.00	0.00	0.00
78000600	THERMOPLASTIC PAVEMENT MARKING - LINE 12"	FOOT	7,707.00	540.00	527.00	3,345.80	2,344.20	150.00	800.00
78000650	THERMOPLASTIC PAVEMENT MARKING - LINE 24"	FOOT	8,147.00	531.00	418.00	5,275.50	1,365.50	32.00	525.00
78008300	POLYUREA PAVEMENT MARKING TYPE II - LETTERS AND SYMBOLS	SQ FT	2,820.00	31.20	0.00	2,385.00	265.80	0.00	138.00
78008310	POLYUREA PAVEMENT MARKING TYPE II - LINE 4"	FOOT	262,445.00	11,930.00	136,200.00	102,617.00	11,523.00	0.00	175.00
78008330	POLYUREA PAVEMENT MARKING TYPE II - LINE 6"	FOOT	3,975.00	715.00	0.00	2,960.00	300.00	0.00	0.00
78008340	POLYUREA PAVEMENT MARKING TYPE II - LINE 8"	FOOT	9,960.00	40.00	7,000.00	2,920.00	0.00	0.00	0.00
78008350	POLYUREA PAVEMENT MARKING TYPE II - LINE 12"	FOOT	3,205.00	254.00	0.00	2,775.00	176.00	0.00	0.00
78008370	POLYUREA PAVEMENT MARKING TYPE II - LINE 24"	FOOT	2,250.00	315.00	0.00	1,695.00	168.00	0.00	72.00
X0327980	PAVEMENT MARKING REMOVAL - WATER BLASTING	SQ FT	1,062.00	240.00	0.00	540.00	282.00	0.00	0.00
* DENOTES SPECIALTY ITEM									

MODEL: I:\MODEL\MHMS
 FILE: MHMS - PavementMarking.dwg
 PROJECT: I:\Projects\0546534\CADDData\Design\Backups\0546534-Int-500.dwg

* DEWITT, MCLEAN, PIATT

USER NAME = farnhamba	DESIGNED -	REVISED -	STATE OF ILLINOIS DEPARTMENT OF TRANSPORTATION	SUMMARY OF QUANTITIES				F.A. RTE.	SECTION	COUNTY	TOTAL SHEETS	SHEET NO.
	DRAWN -	REVISED -										
PLOT SCALE = 40,0000 ' / in.	CHECKED -	REVISED -										
PLOT DATE = 10/15/2019	DATE -	REVISED -			SCALE:	SHEET 1	OF 2	SHEETS	STA.	TO STA.	CONTRACT NO. 46534	ILLINOIS FED. AID PROJECT

SUMMARY OF QUANTITIES

LOCATION OF WORK:	VARIOUS	VARIOUS	VARIOUS	VARIOUS	VARIOUS	VARIOUS
VARIOUS COUNTIES	DEWITT	DEWITT	MCLEAN	MCLEAN	PIATT	PIATT
FUNDING BREAKOUT:	100% STATE	100% STATE	100% STATE	100% STATE	100% STATE	100% STATE
CONSTRUCTION TYPE CODE:	0021	0021	0021	0021	0021	0021

CODE	ITEM	UNIT	TOTAL QUANTITY	QUANTITY	QUANTITY	QUANTITY	QUANTITY	QUANTITY	QUANTITY
X7830060	GROOVING FOR RECESSED PAVEMENT MARKING, LETTERS AND SYMBOLS	SQ FT	15,566.20	2,496.00	358.20	9,189.01	2,770.59	15.60	736.80
X7830070	GROOVING FOR RECESSED PAVEMENT MARKING, 5"	FOOT	593,945.00	53,680.00	162,350.00	273,557.00	84,548.00	1,535.00	18,275.00
X7830074	GROOVING FOR RECESSED PAVEMENT MARKING, 7"	FOOT	11,950.00	865.00	790.00	6,974.50	2,775.50	165.00	380.00
X7830076	GROOVING FOR RECESSED PAVEMENT MARKING, 9"	FOOT	10,080.00	160.00	7,000.00	2,920.00	0.00	0.00	0.00
X7830078	GROOVING FOR RECESSED PAVEMENT MARKING, 13"	FOOT	10,912.00	794.00	527.00	6,120.80	2,520.20	150.00	800.00
X7830090	GROOVING FOR RECESSED PAVEMENT MARKING, 25"	FOOT	10,397.00	846.00	418.00	6,970.50	1,533.50	32.00	597.00
Z0048665	RAILROAD PROTECTIVE LIABILITY INSURANCE	L SUM	1.0	0.1	0.1	0.3	0.3	0.1	0.1

* DENOTES SPECIALTY ITEM

MODEL: I:\MODEL\MHFS
 FILE: MHFS_Plan\Illinois\pwr\PIATT\DOT\Documents\DOT_Offices\PIATT\5\Projects\0546534\CADD\Drawn\Backups\0546534-Int-500.dgn

* DEWITT, MCLEAN, PIATT ** D-SHT PVMNT MRK RPR 20-22

USER NAME = farnhamba PLOT SCALE = 40.0000 ' / in. PLOT DATE = 10/15/2019	DESIGNED - DRAWN - CHECKED - DATE -	REVISED - REVISED - REVISED - REVISED -	STATE OF ILLINOIS DEPARTMENT OF TRANSPORTATION	SUMMARY OF QUANTITIES	SCALE:	SHEET 2 OF 2 SHEETS	STA. TO STA.	CONTRACT NO. 46534 ILLINOIS FED. AID PROJECT
---	--	--	---	------------------------------	--------	---------------------	--------------	---

DEWITT COUNTY

Location #1: I-74 Dewitt/Piatt Co. Line to Mclean/Dewitt Co. Line

Urban/ Rural	Pay Item	Description	Unit	Quantity	White	Yellow	Lt/Rt Arrow	Wrong Way Arrow	Railroad "R"	Railroad "X"	Comb. Arrow	Straight Arrow
RURAL	X0327980	PAVT MARKING REMOVAL	SQ FT	0.0								
RURAL	X7830060	GRV RCSD PM LTR & SYM	SQ FT	0.0								
RURAL	X7830070	GRV RCSD PVT MRKG 5	FOOT	135,500.0								
RURAL	X7830074	GRV RCSD PVT MRKG 7	FOOT	0.0								
RURAL	X7830076	GRV RCSD PVT MRKG 9	FOOT	7,000.0								
RURAL	X7830078	GRV RCSD PVT MRKG 13	FOOT	0.0								
RURAL	X7830090	GRV RCSD PVT MRKG 25	FOOT	0.0								
RURAL	78000100	THPL PVT MK LTR & SYM	SQ FT	0.0			0	0	0	0	0	0
RURAL	78000200	THLP PVT MK LINE 4	FOOT	0.0	0.0	0.0						
RURAL	78000400	THLP PVT MK LINE 6	FOOT	0.0	0.0	0.0						
RURAL	78000500	THLP PVT MK LINE 8	FOOT	0.0	0.0	0.0						
RURAL	78000600	THLP PVT MK LINE 12	FOOT	0.0	0.0	0.0						
RURAL	78000650	THLP PVT MK LINE 24	FOOT	0.0	0.0	0.0						
RURAL	78008300	POLYUREA PM T2 LTR-SY	SQ FT	0.0			0	0	0	0	0	0
RURAL	78008310	POLYUREA PM T2 LN 4	FOOT	135,500.0	75,000.0	60,500.0						
RURAL	78008330	POLYUREA PM T2 LN 6	FOOT	0.0	0.0	0.0						
RURAL	78008340	POLYUREA PM T2 LN 8	FOOT	7,000.0	7,000.0	0.0						
RURAL	78008350	POLYUREA PM T2 LN 12	FOOT	0.0	0.0	0.0						
RURAL	78008370	POLYUREA PM T2 LN 24	FOOT	0.0	0.0	0.0						

Location #2: IL 54 @ I-74 Farmer City

Urban/ Rural	Pay Item	Description	Unit	Quantity	White	Yellow	Lt/Rt Arrow	Wrong Way Arrow	Railroad "R"	Railroad "X"	Comb. Arrow	Straight Arrow
RURAL	X0327980	PAVT MARKING REMOVAL	SQ FT	0.0								
RURAL	X7830060	GRV RCSD PM LTR & SYM	SQ FT	173.4								
RURAL	X7830070	GRV RCSD PVT MRKG 5	FOOT	13,600.0								
RURAL	X7830074	GRV RCSD PVT MRKG 7	FOOT	450.0								
RURAL	X7830076	GRV RCSD PVT MRKG 9	FOOT	0.0								
RURAL	X7830078	GRV RCSD PVT MRKG 13	FOOT	200.0								
RURAL	X7830090	GRV RCSD PVT MRKG 25	FOOT	110.0								
RURAL	78000100	THPL PVT MK LTR & SYM	SQ FT	173.4			8	2	0	0	0	0
RURAL	78000200	THLP PVT MK LINE 4	FOOT	12,900.0	6,800.0	6,100.0						
RURAL	78000400	THLP PVT MK LINE 6	FOOT	450.0	450.0	0.0						
RURAL	78000500	THLP PVT MK LINE 8	FOOT	0.0	0.0	0.0						
RURAL	78000600	THLP PVT MK LINE 12	FOOT	200.0	200.0	0.0						
RURAL	78000650	THLP PVT MK LINE 24	FOOT	110.0	110.0	0.0						
RURAL	78008300	POLYUREA PM T2 LTR-SY	SQ FT	0.0			0	0	0	0	0	0
RURAL	78008310	POLYUREA PM T2 LN 4	FOOT	700.0	350.0	350.0						
RURAL	78008330	POLYUREA PM T2 LN 6	FOOT	0.0	0.0	0.0						
RURAL	78008340	POLYUREA PM T2 LN 8	FOOT	0.0	0.0	0.0						
RURAL	78008350	POLYUREA PM T2 LN 12	FOOT	0.0	0.0	0.0						
RURAL	78008370	POLYUREA PM T2 LN 24	FOOT	0.0	0.0	0.0						

MODEL: s:\MODEL\MHMS
 FILE: mhms_2019\pdm\mcomada.dwg
 PROJECT: D:\Projects\0546534\CADDData\Design\Backups\0546534-21-5-Schedule.dgn

* DEWITT, MCLEAN, PIATT ** D-SHT PVMNT MRK RPR 20-22

USER NAME = farnhamba	DESIGNED -	REVISED -
	DRAWN -	REVISED -
PLOT SCALE = 40.0000 ' / in.	CHECKED -	REVISED -
PLOT DATE = 10/15/2019	DATE -	REVISED -

**STATE OF ILLINOIS
DEPARTMENT OF TRANSPORTATION**

SCHEDULE OF QUANTITIES

SCALE: SHEET 1 OF 29 SHEETS STA. TO STA.

F.A. RTE.	SECTION	COUNTY	TOTAL SHEETS	SHEET NO.
VAR	**	-	45	12
			CONTRACT NO. 46534	
		ILLINOIS FED. AID PROJECT		

DEWITT COUNTY

Location #3: US 150 & IL 54 Farmer City												
Urban/ Rural	Pay Item	Description	Unit	Quantity	White	Yellow	Lt/Rt Arrow	Wrong Way Arrow	Railroad "R"	Railroad "X"	Comb. Arrow	Straight Arrow
RURAL	X0327980	PAVT MARKING REMOVAL	SQ FT	0.0								
RURAL	X7830060	GRV RCSD PM LTR & SYM	SQ FT	0.0								
RURAL	X7830070	GRV RCSD PVT MRKG 5	FOOT	3,400.0								
RURAL	X7830074	GRV RCSD PVT MRKG 7	FOOT	0.0								
RURAL	X7830076	GRV RCSD PVT MRKG 9	FOOT	0.0								
RURAL	X7830078	GRV RCSD PVT MRKG 13	FOOT	0.0								
RURAL	X7830090	GRV RCSD PVT MRKG 25	FOOT	120.0								
RURAL	78000100	THPL PVT MK LTR & SYM	SQ FT	0.0			0	0	0	0	0	0
RURAL	78000200	THLP PVT MK LINE 4	FOOT	3,400.0	1,100.0	2,300.0						
RURAL	78000400	THLP PVT MK LINE 6	FOOT	0.0	0.0	0.0						
RURAL	78000500	THLP PVT MK LINE 8	FOOT	0.0	0.0	0.0						
RURAL	78000600	THLP PVT MK LINE 12	FOOT	0.0	0.0	0.0						
RURAL	78000650	THLP PVT MK LINE 24	FOOT	120.0	120.0	0.0						
RURAL	78008300	POLYUREA PM T2 LTR-SY	SQ FT	0.0			0	0	0	0	0	0
RURAL	78008310	POLYUREA PM T2 LN 4	FOOT	0.0	0.0	0.0						
RURAL	78008330	POLYUREA PM T2 LN 6	FOOT	0.0	0.0	0.0						
RURAL	78008340	POLYUREA PM T2 LN 8	FOOT	0.0	0.0	0.0						
RURAL	78008350	POLYUREA PM T2 LN 12	FOOT	0.0	0.0	0.0						
RURAL	78008370	POLYUREA PM T2 LN 24	FOOT	0.0	0.0	0.0						

Location #4: US 150 & Plum St Farmer City												
Urban/ Rural	Pay Item	Description	Unit	Quantity	White	Yellow	Lt/Rt Arrow	Wrong Way Arrow	Railroad "R"	Railroad "X"	Comb. Arrow	Straight Arrow
RURAL	X0327980	PAVT MARKING REMOVAL	SQ FT	0.0								
RURAL	X7830060	GRV RCSD PM LTR & SYM	SQ FT	122.4								
RURAL	X7830070	GRV RCSD PVT MRKG 5	FOOT	0.0								
RURAL	X7830074	GRV RCSD PVT MRKG 7	FOOT	0.0								
RURAL	X7830076	GRV RCSD PVT MRKG 9	FOOT	0.0								
RURAL	X7830078	GRV RCSD PVT MRKG 13	FOOT	0.0								
RURAL	X7830090	GRV RCSD PVT MRKG 25	FOOT	72.0								
RURAL	78000100	THPL PVT MK LTR & SYM	SQ FT	122.4			0	0	4	2	0	0
RURAL	78000200	THLP PVT MK LINE 4	FOOT	0.0	0.0	0.0						
RURAL	78000400	THLP PVT MK LINE 6	FOOT	0.0	0.0	0.0						
RURAL	78000500	THLP PVT MK LINE 8	FOOT	0.0	0.0	0.0						
RURAL	78000600	THLP PVT MK LINE 12	FOOT	0.0	0.0	0.0						
RURAL	78000650	THLP PVT MK LINE 24	FOOT	72.0	72.0	0.0						
RURAL	78008300	POLYUREA PM T2 LTR-SY	SQ FT	0.0			0	0	0	0	0	0
RURAL	78008310	POLYUREA PM T2 LN 4	FOOT	0.0	0.0	0.0						
RURAL	78008330	POLYUREA PM T2 LN 6	FOOT	0.0	0.0	0.0						
RURAL	78008340	POLYUREA PM T2 LN 8	FOOT	0.0	0.0	0.0						
RURAL	78008350	POLYUREA PM T2 LN 12	FOOT	0.0	0.0	0.0						
RURAL	78008370	POLYUREA PM T2 LN 24	FOOT	0.0	0.0	0.0						

MODEL: s:\MODEL\MHMS
 FILE: hamba: p:\pub\hamboma.dwg
 PROJECT: D:\Projects\0546534\CADD\Drawings\Design\Backups\0546534-Int-Schedule.dgn

* DEWITT, MCLEAN, PIATT ** D-SHT PVMNT MRK RPR 20-22

USER NAME = farnhamba	DESIGNED -	REVISED -
	DRAWN -	REVISED -
PLOT SCALE = 40.0000 ' / in.	CHECKED -	REVISED -
PLOT DATE = 10/15/2019	DATE -	REVISED -

STATE OF ILLINOIS DEPARTMENT OF TRANSPORTATION

SCHEDULE OF QUANTITIES

SCALE: SHEET 2 OF 29 SHEETS STA. TO STA.

F.A. RTE.	SECTION	COUNTY	TOTAL SHEETS	SHEET NO.
VAR	**	-	45	13
CONTRACT NO. 46534			ILLINOIS FED. AID PROJECT	

DEWITT COUNTY

Location #5: IL 54 & Main St. Farmer City												
Urban/ Rural	Pay Item	Description	Unit	Quantity	White	Yellow	Lt/Rt Arrow	Wrong Way Arrow	Railroad "R"	Railroad "X"	Comb. Arrow	Straight Arrow
RURAL	X0327980	PAVT MARKING REMOVAL	SQ FT	0.0								
RURAL	X7830060	GRV RCSD PM LTR & SYM	SQ FT	0.0								
RURAL	X7830070	GRV RCSD PVT MRKG 5	FOOT	0.0								
RURAL	X7830074	GRV RCSD PVT MRKG 7	FOOT	0.0								
RURAL	X7830076	GRV RCSD PVT MRKG 9	FOOT	0.0								
RURAL	X7830078	GRV RCSD PVT MRKG 13	FOOT	0.0								
RURAL	X7830090	GRV RCSD PVT MRKG 25	FOOT	24.0								
RURAL	78000100	THPL PVT MK LTR & SYM	SQ FT	0.0			0	0	0	0	0	0
RURAL	78000200	THLP PVT MK LINE 4	FOOT	0.0	0.0	0.0						
RURAL	78000400	THLP PVT MK LINE 6	FOOT	0.0	0.0	0.0						
RURAL	78000500	THLP PVT MK LINE 8	FOOT	0.0	0.0	0.0						
RURAL	78000600	THLP PVT MK LINE 12	FOOT	0.0	0.0	0.0						
RURAL	78000650	THLP PVT MK LINE 24	FOOT	24.0	24.0	0.0						
RURAL	78008300	POLYUREA PM T2 LTR-SY	SQ FT	0.0			0	0	0	0	0	0
RURAL	78008310	POLYUREA PM T2 LN 4	FOOT	0.0	0.0	0.0						
RURAL	78008330	POLYUREA PM T2 LN 6	FOOT	0.0	0.0	0.0						
RURAL	78008340	POLYUREA PM T2 LN 8	FOOT	0.0	0.0	0.0						
RURAL	78008350	POLYUREA PM T2 LN 12	FOOT	0.0	0.0	0.0						
RURAL	78008370	POLYUREA PM T2 LN 24	FOOT	0.0	0.0	0.0						

Location #6: IL 48 & IL 54												
Urban/ Rural	Pay Item	Description	Unit	Quantity	White	Yellow	Lt/Rt Arrow	Wrong Way Arrow	Railroad "R"	Railroad "X"	Comb. Arrow	Straight Arrow
RURAL	X0327980	PAVT MARKING REMOVAL	SQ FT	0.0								
RURAL	X7830060	GRV RCSD PM LTR & SYM	SQ FT	0.0								
RURAL	X7830070	GRV RCSD PVT MRKG 5	FOOT	650.0								
RURAL	X7830074	GRV RCSD PVT MRKG 7	FOOT	180.0								
RURAL	X7830076	GRV RCSD PVT MRKG 9	FOOT	0.0								
RURAL	X7830078	GRV RCSD PVT MRKG 13	FOOT	92.0								
RURAL	X7830090	GRV RCSD PVT MRKG 25	FOOT	60.0								
RURAL	78000100	THPL PVT MK LTR & SYM	SQ FT	0.0			0	0	0	0	0	0
RURAL	78000200	THLP PVT MK LINE 4	FOOT	650.0	150.0	500.0						
RURAL	78000400	THLP PVT MK LINE 6	FOOT	180.0	180.0	0.0						
RURAL	78000500	THLP PVT MK LINE 8	FOOT	0.0	0.0	0.0						
RURAL	78000600	THLP PVT MK LINE 12	FOOT	92.0	80.0	12.0						
RURAL	78000650	THLP PVT MK LINE 24	FOOT	60.0	60.0	0.0						
RURAL	78008300	POLYUREA PM T2 LTR-SY	SQ FT	0.0			0	0	0	0	0	0
RURAL	78008310	POLYUREA PM T2 LN 4	FOOT	0.0	0.0	0.0						
RURAL	78008330	POLYUREA PM T2 LN 6	FOOT	0.0	0.0	0.0						
RURAL	78008340	POLYUREA PM T2 LN 8	FOOT	0.0	0.0	0.0						
RURAL	78008350	POLYUREA PM T2 LN 12	FOOT	0.0	0.0	0.0						
RURAL	78008370	POLYUREA PM T2 LN 24	FOOT	0.0	0.0	0.0						

MODEL: s:\MODEL\MHMS
 FILE: hamba: p:\pub\hamboma.dwg
 PROJECT: D:\546534\CADDData\Design\Backups\0546534-int-5-schedule.dgn
 OFFICE: D:\546534\CADDData\Design\Backups\0546534-int-5-schedule.dgn

* DEWITT, MCLEAN, PIATT ** D-SHT PVMNT MRK RPR 20-22

USER NAME = farnhamba	DESIGNED -	REVISED -	STATE OF ILLINOIS DEPARTMENT OF TRANSPORTATION	SCHEDULE OF QUANTITIES				F.A. RTE.	SECTION	COUNTY	TOTAL SHEETS	SHEET NO.
PLOT SCALE = 40.0000 ' / in.	DRAWN -	REVISED -						VAR	**	-	45	14
PLOT DATE = 10/15/2019	CHECKED -	REVISED -		SCALE:	SHEET 3	OF 29 SHEETS	STA.	TO STA.	CONTRACT NO. 46534			
	DATE -	REVISED -		ILLINOIS FED. AID PROJECT								

DEWITT COUNTY

Location #7: IL 54 @ Clinton Power Plant

Urban/ Rural	Pay Item	Description	Unit	Quantity	White	Yellow	Lt/Rt Arrow	Wrong Way Arrow	Railroad "R"	Railroad "X"	Comb. Arrow	Straight Arrow
RURAL	X0327980	PAVT MARKING REMOVAL	SQ FT	0.0								
RURAL	X7830060	GRV RCSD PM LTR & SYM	SQ FT	62.4								
RURAL	X7830070	GRV RCSD PVT MRKG 5	FOOT	9,200.0								
RURAL	X7830074	GRV RCSD PVT MRKG 7	FOOT	160.0								
RURAL	X7830076	GRV RCSD PVT MRKG 9	FOOT	0.0								
RURAL	X7830078	GRV RCSD PVT MRKG 13	FOOT	235.0								
RURAL	X7830090	GRV RCSD PVT MRKG 25	FOOT	32.0								
RURAL	78000100	THPL PVT MK LTR & SYM	SQ FT	62.4			4	0	0	0	0	0
RURAL	78000200	THLP PVT MK LINE 4	FOOT	9,200.0	3,950.0	5,250.0						
RURAL	78000400	THLP PVT MK LINE 6	FOOT	160.0	160.0	0.0						
RURAL	78000500	THLP PVT MK LINE 8	FOOT	0.0	0.0	0.0						
RURAL	78000600	THLP PVT MK LINE 12	FOOT	235.0	65.0	170.0						
RURAL	78000650	THLP PVT MK LINE 24	FOOT	32.0	32.0	0.0						
RURAL	78008300	POLYUREA PM T2 LTR-SY	SQ FT	0.0			0	0	0	0	0	0
RURAL	78008310	POLYUREA PM T2 LN 4	FOOT	0.0	0.0	0.0						
RURAL	78008330	POLYUREA PM T2 LN 6	FOOT	0.0	0.0	0.0						
RURAL	78008340	POLYUREA PM T2 LN 8	FOOT	0.0	0.0	0.0						
RURAL	78008350	POLYUREA PM T2 LN 12	FOOT	0.0	0.0	0.0						
RURAL	78008370	POLYUREA PM T2 LN 24	FOOT	0.0	0.0	0.0						

Location #8: IL 54 Thru Clinton (East City Limit to 500 Ft East of US 51)

Urban/ Rural	Pay Item	Description	Unit	Quantity	White	Yellow	Lt/Rt Arrow	Wrong Way Arrow	Railroad "R"	Railroad "X"	Comb. Arrow	Straight Arrow
URBAN	X0327980	PAVT MARKING REMOVAL	SQ FT	200.0								
URBAN	X7830060	GRV RCSD PM LTR & SYM	SQ FT	1,903.2								
URBAN	X7830070	GRV RCSD PVT MRKG 5	FOOT	31,790.0								
URBAN	X7830074	GRV RCSD PVT MRKG 7	FOOT	615.0								
URBAN	X7830076	GRV RCSD PVT MRKG 9	FOOT	0.0								
URBAN	X7830078	GRV RCSD PVT MRKG 13	FOOT	460.0								
URBAN	X7830090	GRV RCSD PVT MRKG 25	FOOT	590.0								
URBAN	78000100	THPL PVT MK LTR & SYM	SQ FT	1,903.2			122	0	0	0	0	0
URBAN	78000200	THLP PVT MK LINE 4	FOOT	31,000.0	3,800.0	27,200.0						
URBAN	78000400	THLP PVT MK LINE 6	FOOT	0.0	0.0	0.0						
URBAN	78000500	THLP PVT MK LINE 8	FOOT	0.0	0.0	0.0						
URBAN	78000600	THLP PVT MK LINE 12	FOOT	240.0	0.0	240.0						
URBAN	78000650	THLP PVT MK LINE 24	FOOT	275.0	275.0	0.0						
URBAN	78008300	POLYUREA PM T2 LTR-SY	SQ FT	0.0			0	0	0	0	0	0
URBAN	78008310	POLYUREA PM T2 LN 4	FOOT	790.0	0.0	790.0						
URBAN	78008330	POLYUREA PM T2 LN 6	FOOT	615.0	615.0	0.0						
URBAN	78008340	POLYUREA PM T2 LN 8	FOOT	0.0	0.0	0.0						
URBAN	78008350	POLYUREA PM T2 LN 12	FOOT	220.0	220.0	0.0						
URBAN	78008370	POLYUREA PM T2 LN 24	FOOT	315.0	315.0	0.0						

MODEL: s:\MODEL\MHMF5
 FILE: mhmf5_pavt.dwg
 PROJECT: D:\Projects\0546534\CADDData\Design\Backups\0546534-int-5-schedule.dgn

* DEWITT, MCLEAN, PIATT ** D-5HT PVMNT MRK RPR 20-22

USER NAME = farnhamba DESIGNED - DRAWN - PLOT SCALE = 40.0000 ' / in. CHECKED - PLOT DATE = 10/15/2019 DATE -	REVISED - REVISED - REVISED - REVISED -	STATE OF ILLINOIS DEPARTMENT OF TRANSPORTATION	SCHEDULE OF QUANTITIES	SCALE: SHEET 4 OF 29 SHEETS STA. TO STA.
		F.A. RTE. SECTION COUNTY TOTAL SHEETS SHEET NO. VAR ** - 45 15 CONTRACT NO. 46534		ILLINOIS FED. AID PROJECT

DEWITT COUNTY

Location #9: IL 10 @ IL 54 (East Side) Clinton

Urban/ Rural	Pay Item	Description	Unit	Quantity	White	Yellow	Lt/Rt Arrow	Wrong Way Arrow	Railroad "R"	Railroad "X"	Comb. Arrow	Straight Arrow
URBAN	X0327980	PAVT MARKING REMOVAL	SQ FT	0.0								
URBAN	X7830060	GRV RCSD PM LTR & SYM	SQ FT	0.0								
URBAN	X7830070	GRV RCSD PVT MRKG 5	FOOT	500.0								
URBAN	X7830074	GRV RCSD PVT MRKG 7	FOOT	150.0								
URBAN	X7830076	GRV RCSD PVT MRKG 9	FOOT	0.0								
URBAN	X7830078	GRV RCSD PVT MRKG 13	FOOT	70.0								
URBAN	X7830090	GRV RCSD PVT MRKG 25	FOOT	36.0								
URBAN	78000100	THPL PVT MK LTR & SYM	SQ FT	0.0			0	0	0	0	0	0
URBAN	78000200	THLP PVT MK LINE 4	FOOT	500.0	0.0	500.0						
URBAN	78000400	THLP PVT MK LINE 6	FOOT	150.0	150.0	0.0						
URBAN	78000500	THLP PVT MK LINE 8	FOOT	0.0	0.0	0.0						
URBAN	78000600	THLP PVT MK LINE 12	FOOT	70.0	70.0	0.0						
URBAN	78000650	THLP PVT MK LINE 24	FOOT	36.0	36.0	0.0						
URBAN	78008300	POLYUREA PM T2 LTR-SY	SQ FT	0.0			0	0	0	0	0	0
URBAN	78008310	POLYUREA PM T2 LN 4	FOOT	0.0	0.0	0.0						
URBAN	78008330	POLYUREA PM T2 LN 6	FOOT	0.0	0.0	0.0						
URBAN	78008340	POLYUREA PM T2 LN 8	FOOT	0.0	0.0	0.0						
URBAN	78008350	POLYUREA PM T2 LN 12	FOOT	0.0	0.0	0.0						
URBAN	78008370	POLYUREA PM T2 LN 24	FOOT	0.0	0.0	0.0						

Location #10: IL 10 @ IL 54 (West Side) Clinton

Urban/ Rural	Pay Item	Description	Unit	Quantity	White	Yellow	Lt/Rt Arrow	Wrong Way Arrow	Railroad "R"	Railroad "X"	Comb. Arrow	Straight Arrow
URBAN	X0327980	PAVT MARKING REMOVAL	SQ FT	40.0								
URBAN	X7830060	GRV RCSD PM LTR & SYM	SQ FT	31.2								
URBAN	X7830070	GRV RCSD PVT MRKG 5	FOOT	1,800.0								
URBAN	X7830074	GRV RCSD PVT MRKG 7	FOOT	100.0								
URBAN	X7830076	GRV RCSD PVT MRKG 9	FOOT	40.0								
URBAN	X7830078	GRV RCSD PVT MRKG 13	FOOT	114.0								
URBAN	X7830090	GRV RCSD PVT MRKG 25	FOOT	0.0								
URBAN	78000100	THPL PVT MK LTR & SYM	SQ FT	0.0			0	0	0	0	0	0
URBAN	78000200	THLP PVT MK LINE 4	FOOT	960.0	0.0	960.0						
URBAN	78000400	THLP PVT MK LINE 6	FOOT	0.0	0.0	0.0						
URBAN	78000500	THLP PVT MK LINE 8	FOOT	0.0	0.0	0.0						
URBAN	78000600	THLP PVT MK LINE 12	FOOT	80.0	0.0	80.0						
URBAN	78000650	THLP PVT MK LINE 24	FOOT	0.0	0.0	0.0						
URBAN	78008300	POLYUREA PM T2 LTR-SY	SQ FT	31.2			2	0	0	0	0	0
URBAN	78008310	POLYUREA PM T2 LN 4	FOOT	840.0	200.0	640.0						
URBAN	78008330	POLYUREA PM T2 LN 6	FOOT	100.0	100.0	0.0						
URBAN	78008340	POLYUREA PM T2 LN 8	FOOT	40.0	40.0	0.0						
URBAN	78008350	POLYUREA PM T2 LN 12	FOOT	34.0	34.0	0.0						
URBAN	78008370	POLYUREA PM T2 LN 24	FOOT	0.0	0.0	0.0						

MODEL: s:\MODEL\MHMS
 FILE: mhms_2019\pdm\mcomada.dwg
 PROJECT: D:\Projects\46534\CADD\Drawings\Design\Backups\46534-Int-5-Schedule.dgn

* DEWITT, MCLEAN, PIATT ** D-SHT PVMNT MRK RPR 20-22

USER NAME = farnhamba DESIGNED - DRAWN - PLOT SCALE = 40.0000 ' / in. CHECKED - PLOT DATE = 10/15/2019 DATE -	REVISED - REVISED - REVISED - REVISED -	STATE OF ILLINOIS DEPARTMENT OF TRANSPORTATION	SCHEDULE OF QUANTITIES	F.A. RTE. VAR SECTION COUNTY CONTRACT NO. 46534 ILLINOIS FED. AID PROJECT	TOTAL SHEETS 45 SHEET NO. 16
SCALE:			SHEET 5 OF 29 SHEETS STA. TO STA.		

DEWITT COUNTY

Location #11: Bus US 51 from Revere Rd to Evans Dr (Clinton)												
Urban/ Rural	Pay Item	Description	Unit	Quantity	White	Yellow	Lt/Rt Arrow	Wrong Way Arrow	Railroad "R"	Railroad "X"	Comb. Arrow	Straight Arrow
URBAN	X0327980	PAVT MARKING REMOVAL	SQ FT	0.0								
URBAN	X7830060	GRV RCSD PM LTR & SYM	SQ FT	93.6								
URBAN	X7830070	GRV RCSD PVT MRKG 5	FOOT	3,080.0								
URBAN	X7830074	GRV RCSD PVT MRKG 7	FOOT	0.0								
URBAN	X7830076	GRV RCSD PVT MRKG 9	FOOT	120.0								
URBAN	X7830078	GRV RCSD PVT MRKG 13	FOOT	0.0								
URBAN	X7830090	GRV RCSD PVT MRKG 25	FOOT	0.0								
URBAN	78000100	THPL PVT MK LTR & SYM	SQ FT	93.6			6	0	0	0	0	0
URBAN	78000200	THLP PVT MK LINE 4	FOOT	3,080.0	0.0	3,080.0						
URBAN	78000400	THLP PVT MK LINE 6	FOOT	0.0	0.0	0.0						
URBAN	78000500	THLP PVT MK LINE 8	FOOT	120.0	0.0	120.0						
URBAN	78000600	THLP PVT MK LINE 12	FOOT	0.0	0.0	0.0						
URBAN	78000650	THLP PVT MK LINE 24	FOOT	0.0	0.0	0.0						
URBAN	78008300	POLYUREA PM T2 LTR-SY	SQ FT	0.0			0	0	0	0	0	0
URBAN	78008310	POLYUREA PM T2 LN 4	FOOT	0.0	0.0	0.0						
URBAN	78008330	POLYUREA PM T2 LN 6	FOOT	0.0	0.0	0.0						
URBAN	78008340	POLYUREA PM T2 LN 8	FOOT	0.0	0.0	0.0						
URBAN	78008350	POLYUREA PM T2 LN 12	FOOT	0.0	0.0	0.0						
URBAN	78008370	POLYUREA PM T2 LN 24	FOOT	0.0	0.0	0.0						

Location #12 Bus US 51 from 400 Ft South of IL 54 to 150 Ft North of Washington St (Clinton)												
Urban/ Rural	Pay Item	Description	Unit	Quantity	White	Yellow	Lt/Rt Arrow	Wrong Way Arrow	Railroad "R"	Railroad "X"	Comb. Arrow	Straight Arrow
URBAN	X0327980	PAVT MARKING REMOVAL	SQ FT	0.0								
URBAN	X7830060	GRV RCSD PM LTR & SYM	SQ FT	468.0								
URBAN	X7830070	GRV RCSD PVT MRKG 5	FOOT	6,210.0								
URBAN	X7830074	GRV RCSD PVT MRKG 7	FOOT	0.0								
URBAN	X7830076	GRV RCSD PVT MRKG 9	FOOT	0.0								
URBAN	X7830078	GRV RCSD PVT MRKG 13	FOOT	150.0								
URBAN	X7830090	GRV RCSD PVT MRKG 25	FOOT	220.0								
URBAN	78000100	THPL PVT MK LTR & SYM	SQ FT	468.0			30	0	0	0	0	0
URBAN	78000200	THLP PVT MK LINE 4	FOOT	6,210.0	560.0	5,650.0						
URBAN	78000400	THLP PVT MK LINE 6	FOOT	0.0	0.0	0.0						
URBAN	78000500	THLP PVT MK LINE 8	FOOT	0.0	0.0	0.0						
URBAN	78000600	THLP PVT MK LINE 12	FOOT	150.0	0.0	150.0						
URBAN	78000650	THLP PVT MK LINE 24	FOOT	220.0	220.0	0.0						
URBAN	78008300	POLYUREA PM T2 LTR-SY	SQ FT	0.0			0	0	0	0	0	0
URBAN	78008310	POLYUREA PM T2 LN 4	FOOT	0.0	0.0	0.0						
URBAN	78008330	POLYUREA PM T2 LN 6	FOOT	0.0	0.0	0.0						
URBAN	78008340	POLYUREA PM T2 LN 8	FOOT	0.0	0.0	0.0						
URBAN	78008350	POLYUREA PM T2 LN 12	FOOT	0.0	0.0	0.0						
URBAN	78008370	POLYUREA PM T2 LN 24	FOOT	0.0	0.0	0.0						

MODEL: I:\MODEL\MH15
 FILE: MH15.dwg
 Path: \\hambam.com\data\illinois.gov\PIWDOT\Documents\DOT_Offices\Clinton\5\Projects\0546534\CADDData\Design\Backups\0546534-11-5-Schedule.dgn

USER NAME = farnhamba	DESIGNED -	REVISED -	
	DRAWN -	REVISED -	
PLOT SCALE = 40.0000 ' / in.	CHECKED -	REVISED -	
PLOT DATE = 10/15/2019	DATE -	REVISED -	

**STATE OF ILLINOIS
DEPARTMENT OF TRANSPORTATION**

SCHEDULE OF QUANTITIES

SCALE: SHEET 6 OF 29 SHEETS STA. TO STA.

* DEWITT, MCLEAN, PIATT ** D-SHT PVMNT MRK RPR 20-22

F.A. RTE.	SECTION	COUNTY	TOTAL SHEETS	SHEET NO.
VAR	**	-	45	17
CONTRACT NO. 46534				
		ILLINOIS	FED. AID PROJECT	

DEWITT COUNTY

Location #13: NB US 51 @ Wapella (Sta 1303+96 - Sta 1342+40, Sta 1359+00 - Sta 1399+60, & Sta 1460+70 - Sta 1461+20)												
Urban/ Rural	Pay Item	Description	Unit	Quantity	White	Yellow	Lt/Rt Arrow	Wrong Way Arrow	Railroad "R"	Railroad "X"	Comb. Arrow	Straight Arrow
URBAN	X0327980	PAVT MARKING REMOVAL	SQ FT	0.0								
URBAN	X7830060	GRV RCSD PM LTR & SYM	SQ FT	0.0								
URBAN	X7830070	GRV RCSD PVT MRKG 5	FOOT	10,300.0								
URBAN	X7830074	GRV RCSD PVT MRKG 7	FOOT	0.0								
URBAN	X7830076	GRV RCSD PVT MRKG 9	FOOT	0.0								
URBAN	X7830078	GRV RCSD PVT MRKG 13	FOOT	0.0								
URBAN	X7830090	GRV RCSD PVT MRKG 25	FOOT	0.0								
URBAN	78000100	THPL PVT MK LTR & SYM	SQ FT	0.0			0	0	0	0	0	0
URBAN	78000200	THLP PVT MK LINE 4	FOOT	0.0	0.0	0.0						
URBAN	78000400	THLP PVT MK LINE 6	FOOT	0.0	0.0	0.0						
URBAN	78000500	THLP PVT MK LINE 8	FOOT	0.0	0.0	0.0						
URBAN	78000600	THLP PVT MK LINE 12	FOOT	0.0	0.0	0.0						
URBAN	78000650	THLP PVT MK LINE 24	FOOT	0.0	0.0	0.0						
URBAN	78008300	POLYUREA PM T2 LTR-SY	SQ FT	0.0			0	0	0	0	0	0
URBAN	78008310	POLYUREA PM T2 LN 4	FOOT	10,300.0	10,200.0	100.0						
URBAN	78008330	POLYUREA PM T2 LN 6	FOOT	0.0	0.0	0.0						
URBAN	78008340	POLYUREA PM T2 LN 8	FOOT	0.0	0.0	0.0						
URBAN	78008350	POLYUREA PM T2 LN 12	FOOT	0.0	0.0	0.0						
URBAN	78008370	POLYUREA PM T2 LN 24	FOOT	0.0	0.0	0.0						

Dewitt County Totals:														
	Pay Item	Description	Unit	Urban	Rural	Quantity	White	Yellow	Lt/Rt Arrow	Wrong Way Arrow	Railroad "R"	Railroad "X"	Comb. Arrow	Straight Arrow
	X0327980	PAVT MARKING REMOVAL	SQ FT	240.0	0.0	240.0								
	X7830060	GRV RCSD PM LTR & SYM	SQ FT	2,496.0	358.2	2,854.2								
	X7830070	GRV RCSD PVT MRKG 5	FOOT	53,680.0	162,350.0	216,030.0								
	X7830074	GRV RCSD PVT MRKG 7	FOOT	865.0	790.0	1,655.0								
	X7830076	GRV RCSD PVT MRKG 9	FOOT	160.0	7,000.0	7,160.0								
	X7830078	GRV RCSD PVT MRKG 13	FOOT	794.0	527.0	1,321.0								
	X7830090	GRV RCSD PVT MRKG 25	FOOT	846.0	418.0	1,264.0								
	78000100	THPL PVT MK LTR & SYM	SQ FT	2,464.8	358.2	2,823.0			170	2	4	2	0	0
	78000200	THLP PVT MK LINE 4	FOOT	41,750.0	26,150.0	67,900.0	16,360.0	51,540.0						
	78000400	THLP PVT MK LINE 6	FOOT	150.0	790.0	940.0	940.0	0.0						
	78000500	THLP PVT MK LINE 8	FOOT	120.0	0.0	120.0	0.0	120.0						
	78000600	THLP PVT MK LINE 12	FOOT	540.0	527.0	1,067.0	415.0	652.0						
	78000650	THLP PVT MK LINE 24	FOOT	531.0	418.0	949.0	949.0	0.0						
	78008300	POLYUREA PM T2 LTR-SY	SQ FT	31.2	0.0	31.2			2	0	0	0	0	0
	78008310	POLYUREA PM T2 LN 4	FOOT	11,930.0	136,200.0	148,130.0	85,750.0	62,380.0						
	78008330	POLYUREA PM T2 LN 6	FOOT	715.0	0.0	715.0	715.0	0.0						
	78008340	POLYUREA PM T2 LN 8	FOOT	40.0	7,000.0	7,040.0	7,040.0	0.0						
	78008350	POLYUREA PM T2 LN 12	FOOT	254.0	0.0	254.0	254.0	0.0						
	78008370	POLYUREA PM T2 LN 24	FOOT	315.0	0.0	315.0	315.0	0.0						

MODEL: s:\MODEL\MHFS
 FILE: hmba: p:\pub\hmba\maha.dwg:PWIDOT\Documents\DOT - Office\Drawings - 5\Projects\0546534\CADD\Drawings\Backups\0546534-ent-5-schedule.dgn

* DEWITT, MCLEAN, PIATT ** D-5HT PVMNT MRK RPR 20-22

USER NAME = farnhamba DESIGNED - DRAWN - PLOT SCALE = 40.0000 ' / in. CHECKED - PLOT DATE = 10/15/2019 DATE -	REVISED - REVISED - REVISED - REVISED -	STATE OF ILLINOIS DEPARTMENT OF TRANSPORTATION	SCHEDULE OF QUANTITIES	F.A. RTE. SECTION COUNTY TOTAL SHEETS SHEET NO.	CONTRACT NO. 46534 ILLINOIS FED. AID PROJECT
		SCALE:	SHEET 7 OF 29 SHEETS	STA.	TO STA.

MCLEAN COUNTY

Location #1: US 136 @ RR @ McLean/Champaign Co Line

Urban/ Rural	Pay Item	Description	Unit	Quantity	White	Yellow	Lt/Rt Arrow	Wrong Way Arrow	Railroad "R"	Railroad "X"	Comb. Arrow	Straight Arrow
RURAL	X0327980	PAVT MARKING REMOVAL	SQ FT	0.0								
RURAL	X7830060	GRV RCSD PM LTR & SYM	SQ FT	122.4								
RURAL	X7830070	GRV RCSD PVT MRKG 5	FOOT	0.0								
RURAL	X7830074	GRV RCSD PVT MRKG 7	FOOT	0.0								
RURAL	X7830076	GRV RCSD PVT MRKG 9	FOOT	0.0								
RURAL	X7830078	GRV RCSD PVT MRKG 13	FOOT	0.0								
RURAL	X7830090	GRV RCSD PVT MRKG 25	FOOT	72.0								
RURAL	78000100	THPL PVT MK LTR & SYM	SQ FT	122.4			0	0	4	2	0	0
RURAL	78000200	THLP PVT MK LINE 4	FOOT	0.0	0.0	0.0						
RURAL	78000400	THLP PVT MK LINE 6	FOOT	0.0	0.0	0.0						
RURAL	78000500	THLP PVT MK LINE 8	FOOT	0.0	0.0	0.0						
RURAL	78000600	THLP PVT MK LINE 12	FOOT	0.0	0.0	0.0						
RURAL	78000650	THLP PVT MK LINE 24	FOOT	72.0	72.0	0.0						
RURAL	78008300	POLYUREA PM T2 LTR-SY	SQ FT	0.0			0	0	0	0	0	0
RURAL	78008310	POLYUREA PM T2 LN 4	FOOT	0.0	0.0	0.0						
RURAL	78008330	POLYUREA PM T2 LN 6	FOOT	0.0	0.0	0.0						
RURAL	78008340	POLYUREA PM T2 LN 8	FOOT	0.0	0.0	0.0						
RURAL	78008350	POLYUREA PM T2 LN 12	FOOT	0.0	0.0	0.0						
RURAL	78008370	POLYUREA PM T2 LN 24	FOOT	0.0	0.0	0.0						

Location #2: US 136 & IL 54

Urban/ Rural	Pay Item	Description	Unit	Quantity	White	Yellow	Lt/Rt Arrow	Wrong Way Arrow	Railroad "R"	Railroad "X"	Comb. Arrow	Straight Arrow
RURAL	X0327980	PAVT MARKING REMOVAL	SQ FT	0.0								
RURAL	X7830060	GRV RCSD PM LTR & SYM	SQ FT	122.4								
RURAL	X7830070	GRV RCSD PVT MRKG 5	FOOT	530.0								
RURAL	X7830074	GRV RCSD PVT MRKG 7	FOOT	270.0								
RURAL	X7830076	GRV RCSD PVT MRKG 9	FOOT	0.0								
RURAL	X7830078	GRV RCSD PVT MRKG 13	FOOT	160.0								
RURAL	X7830090	GRV RCSD PVT MRKG 25	FOOT	155.0								
RURAL	78000100	THPL PVT MK LTR & SYM	SQ FT	122.4			0	0	4	2	0	0
RURAL	78000200	THLP PVT MK LINE 4	FOOT	530.0	530.0	0.0						
RURAL	78000400	THLP PVT MK LINE 6	FOOT	270.0	270.0	0.0						
RURAL	78000500	THLP PVT MK LINE 8	FOOT	0.0	0.0	0.0						
RURAL	78000600	THLP PVT MK LINE 12	FOOT	160.0	160.0	0.0						
RURAL	78000650	THLP PVT MK LINE 24	FOOT	155.0	155.0	0.0						
RURAL	78008300	POLYUREA PM T2 LTR-SY	SQ FT	0.0			0	0	0	0	0	0
RURAL	78008310	POLYUREA PM T2 LN 4	FOOT	0.0	0.0	0.0						
RURAL	78008330	POLYUREA PM T2 LN 6	FOOT	0.0	0.0	0.0						
RURAL	78008340	POLYUREA PM T2 LN 8	FOOT	0.0	0.0	0.0						
RURAL	78008350	POLYUREA PM T2 LN 12	FOOT	0.0	0.0	0.0						
RURAL	78008370	POLYUREA PM T2 LN 24	FOOT	0.0	0.0	0.0						

MODEL: I:\MODEL\MHFS
 FILE: MHFS_Plan\pdm\mcomada.dwg
 PROJECT: D:\Projects\0546534\CADDData\Design\Backups\0546534-int-5-schedule.dgn

* DEWITT, MCLEAN, PIATT ** D-5HT PVMNT MRK RPR 20-22

USER NAME = farnhamba DESIGNED - DRAWN - PLOT SCALE = 40.0000 ' / in. CHECKED - PLOT DATE = 10/15/2019 DATE -	REVISED - REVISED - REVISED - REVISED -	STATE OF ILLINOIS DEPARTMENT OF TRANSPORTATION	SCHEDULE OF QUANTITIES	F.A. RTE. SECTION COUNTY TOTAL SHEETS SHEET NO.	CONTRACT NO. 46534 ILLINOIS FED. AID PROJECT
		SCALE:	SHEET 8 OF 29 SHEETS	STA.	TO STA.

MCLEAN COUNTY

Location #3: US 136 @ RR 1/2 mile East of I-74

Urban/ Rural	Pay Item	Description	Unit	Quantity	White	Yellow	Lt/Rt Arrow	Wrong Way Arrow	Railroad "R"	Railroad "X"	Comb. Arrow	Straight Arrow
RURAL	X0327980	PAVT MARKING REMOVAL	SQ FT	266.4								
RURAL	X7830060	GRV RCSD PM LTR & SYM	SQ FT	0.0								
RURAL	X7830070	GRV RCSD PVT MRKG 5	FOOT	0.0								
RURAL	X7830074	GRV RCSD PVT MRKG 7	FOOT	0.0								
RURAL	X7830076	GRV RCSD PVT MRKG 9	FOOT	0.0								
RURAL	X7830078	GRV RCSD PVT MRKG 13	FOOT	0.0								
RURAL	X7830090	GRV RCSD PVT MRKG 25	FOOT	0.0								
RURAL	78000100	THPL PVT MK LTR & SYM	SQ FT	0.0			0	0	0	0	0	0
RURAL	78000200	THLP PVT MK LINE 4	FOOT	0.0	0.0	0.0						
RURAL	78000400	THLP PVT MK LINE 6	FOOT	0.0	0.0	0.0						
RURAL	78000500	THLP PVT MK LINE 8	FOOT	0.0	0.0	0.0						
RURAL	78000600	THLP PVT MK LINE 12	FOOT	0.0	0.0	0.0						
RURAL	78000650	THLP PVT MK LINE 24	FOOT	0.0	0.0	0.0						
RURAL	78008300	POLYUREA PM T2 LTR-SY	SQ FT	0.0			0	0	0	0	0	0
RURAL	78008310	POLYUREA PM T2 LN 4	FOOT	0.0	0.0	0.0						
RURAL	78008330	POLYUREA PM T2 LN 6	FOOT	0.0	0.0	0.0						
RURAL	78008340	POLYUREA PM T2 LN 8	FOOT	0.0	0.0	0.0						
RURAL	78008350	POLYUREA PM T2 LN 12	FOOT	0.0	0.0	0.0						
RURAL	78008370	POLYUREA PM T2 LN 24	FOOT	0.0	0.0	0.0						

Location #4: US 136 @ I-74

Urban/ Rural	Pay Item	Description	Unit	Quantity	White	Yellow	Lt/Rt Arrow	Wrong Way Arrow	Railroad "R"	Railroad "X"	Comb. Arrow	Straight Arrow
RURAL	X0327980	PAVT MARKING REMOVAL	SQ FT	0.0								
RURAL	X7830060	GRV RCSD PM LTR & SYM	SQ FT	124.8								
RURAL	X7830070	GRV RCSD PVT MRKG 5	FOOT	0.0								
RURAL	X7830074	GRV RCSD PVT MRKG 7	FOOT	0.0								
RURAL	X7830076	GRV RCSD PVT MRKG 9	FOOT	0.0								
RURAL	X7830078	GRV RCSD PVT MRKG 13	FOOT	0.0								
RURAL	X7830090	GRV RCSD PVT MRKG 25	FOOT	0.0								
RURAL	78000100	THPL PVT MK LTR & SYM	SQ FT	124.8			8	0	0	0	0	0
RURAL	78000200	THLP PVT MK LINE 4	FOOT	0.0	0.0	0.0						
RURAL	78000400	THLP PVT MK LINE 6	FOOT	0.0	0.0	0.0						
RURAL	78000500	THLP PVT MK LINE 8	FOOT	0.0	0.0	0.0						
RURAL	78000600	THLP PVT MK LINE 12	FOOT	0.0	0.0	0.0						
RURAL	78000650	THLP PVT MK LINE 24	FOOT	0.0	0.0	0.0						
RURAL	78008300	POLYUREA PM T2 LTR-SY	SQ FT	0.0			0	0	0	0	0	0
RURAL	78008310	POLYUREA PM T2 LN 4	FOOT	0.0	0.0	0.0						
RURAL	78008330	POLYUREA PM T2 LN 6	FOOT	0.0	0.0	0.0						
RURAL	78008340	POLYUREA PM T2 LN 8	FOOT	0.0	0.0	0.0						
RURAL	78008350	POLYUREA PM T2 LN 12	FOOT	0.0	0.0	0.0						
RURAL	78008370	POLYUREA PM T2 LN 24	FOOT	0.0	0.0	0.0						

MODEL: I:\MODEL\MHMS
FILE: MHMS_Plan\I74McLean.dwg
PROJECT: I:\Projects\0546534\CADDData\Design\Backups\0546534-Int-5-Schedule.dgn

* DEWITT, MCLEAN, PIATT ** D-SHT PVMNT MRK RPR 20-22

USER NAME = farnhamba	DESIGNED -	REVISED -
	DRAWN -	REVISED -
PLOT SCALE = 40.0000 ' / in.	CHECKED -	REVISED -
PLOT DATE = 10/15/2019	DATE -	REVISED -

**STATE OF ILLINOIS
DEPARTMENT OF TRANSPORTATION**

SCHEDULE OF QUANTITIES

SCALE: SHEET 9 OF 29 SHEETS STA. TO STA.

F.A. RTE.	SECTION	COUNTY	TOTAL SHEETS	SHEET NO.
VAR	**	-	45	20
CONTRACT NO. 46534				
		ILLINOIS	FED. AID PROJECT	

MCLEAN COUNTY

Location #5: US 136 & LeRoy Spur (3.5 miles West of I-74)

Urban/ Rural	Pay Item	Description	Unit	Quantity	White	Yellow	Lt/Rt Arrow	Wrong Way Arrow	Railroad "R"	Railroad "X"	Comb. Arrow	Straight Arrow
RURAL	X0327980	PAVT MARKING REMOVAL	SQ FT	0.0								
RURAL	X7830060	GRV RCSD PM LTR & SYM	SQ FT	0.0								
RURAL	X7830070	GRV RCSD PVT MRKG 5	FOOT	385.0								
RURAL	X7830074	GRV RCSD PVT MRKG 7	FOOT	120.0								
RURAL	X7830076	GRV RCSD PVT MRKG 9	FOOT	0.0								
RURAL	X7830078	GRV RCSD PVT MRKG 13	FOOT	70.0								
RURAL	X7830090	GRV RCSD PVT MRKG 25	FOOT	32.0								
RURAL	78000100	THPL PVT MK LTR & SYM	SQ FT	0.0			0	0	0	0	0	0
RURAL	78000200	THLP PVT MK LINE 4	FOOT	385.0	385.0	0.0						
RURAL	78000400	THLP PVT MK LINE 6	FOOT	120.0	120.0	0.0						
RURAL	78000500	THLP PVT MK LINE 8	FOOT	0.0	0.0	0.0						
RURAL	78000600	THLP PVT MK LINE 12	FOOT	70.0	70.0	0.0						
RURAL	78000650	THLP PVT MK LINE 24	FOOT	32.0	32.0	0.0						
RURAL	78008300	POLYUREA PM T2 LTR-SY	SQ FT	0.0			0	0	0	0	0	0
RURAL	78008310	POLYUREA PM T2 LN 4	FOOT	0.0	0.0	0.0						
RURAL	78008330	POLYUREA PM T2 LN 6	FOOT	0.0	0.0	0.0						
RURAL	78008340	POLYUREA PM T2 LN 8	FOOT	0.0	0.0	0.0						
RURAL	78008350	POLYUREA PM T2 LN 12	FOOT	0.0	0.0	0.0						
RURAL	78008370	POLYUREA PM T2 LN 24	FOOT	0.0	0.0	0.0						

Location #6: US 136 Vine St to Rowe Dr Heyworth

Urban/ Rural	Pay Item	Description	Unit	Quantity	White	Yellow	Lt/Rt Arrow	Wrong Way Arrow	Railroad "R"	Railroad "X"	Comb. Arrow	Straight Arrow
RURAL	X0327980	PAVT MARKING REMOVAL	SQ FT	0.0								
RURAL	X7830060	GRV RCSD PM LTR & SYM	SQ FT	485.4								
RURAL	X7830070	GRV RCSD PVT MRKG 5	FOOT	14,750.0								
RURAL	X7830074	GRV RCSD PVT MRKG 7	FOOT	300.0								
RURAL	X7830076	GRV RCSD PVT MRKG 9	FOOT	0.0								
RURAL	X7830078	GRV RCSD PVT MRKG 13	FOOT	490.0								
RURAL	X7830090	GRV RCSD PVT MRKG 25	FOOT	162.0								
RURAL	78000100	THPL PVT MK LTR & SYM	SQ FT	280.8			18	0	0	0	0	0
RURAL	78000200	THLP PVT MK LINE 4	FOOT	6,170.0	1,050.0	5,120.0						
RURAL	78000400	THLP PVT MK LINE 6	FOOT	0.0	0.0	0.0						
RURAL	78000500	THLP PVT MK LINE 8	FOOT	0.0	0.0	0.0						
RURAL	78000600	THLP PVT MK LINE 12	FOOT	340.0	0.0	340.0						
RURAL	78000650	THLP PVT MK LINE 24	FOOT	90.0	90.0	0.0						
RURAL	78008300	POLYUREA PM T2 LTR-SY	SQ FT	204.6			10	2	0	0	0	0
RURAL	78008310	POLYUREA PM T2 LN 4	FOOT	8,580.0	4,450.0	4,130.0						
RURAL	78008330	POLYUREA PM T2 LN 6	FOOT	300.0	300.0	0.0						
RURAL	78008340	POLYUREA PM T2 LN 8	FOOT	0.0	0.0	0.0						
RURAL	78008350	POLYUREA PM T2 LN 12	FOOT	150.0	150.0	0.0						
RURAL	78008370	POLYUREA PM T2 LN 24	FOOT	72.0	72.0	0.0						

MODEL: I:\MODEL\MH\MS
 FILE: Mh\MS_Plan\Illum\comada.dwg
 PROJECT: D:\Projects\0546534\CADD\Drawings\Design\Backups\0546534-Int-5-Schedule.dgn

USER NAME = farnhamba	DESIGNED -	REVISED -
	DRAWN -	REVISED -
PLOT SCALE = 40.0000 ' / in.	CHECKED -	REVISED -
PLOT DATE = 10/15/2019	DATE -	REVISED -

**STATE OF ILLINOIS
DEPARTMENT OF TRANSPORTATION**

SCHEDULE OF QUANTITIES

SCALE: SHEET 10 OF 29 SHEETS STA. TO STA.

* DEWITT, MCLEAN, PIATT ** D-SHT PVMNT MRK RPR 20-22

F.A. RTE.	SECTION	COUNTY	TOTAL SHEETS	SHEET NO.
VAR	**	-	45	21
			CONTRACT NO. 46534	
		ILLINOIS	FED. AID PROJECT	

MCLEAN COUNTY

Location #7: US 136 Frontage Rd to West St in McLean

Urban/ Rural	Pay Item	Description	Unit	Quantity	White	Yellow	Lt/Rt Arrow	Wrong Way Arrow	Railroad "R"	Railroad "X"	Comb. Arrow	Straight Arrow
RURAL	X0327980	PAVT MARKING REMOVAL	SQ FT	0.0								
RURAL	X7830060	GRV RCSD PM LTR & SYM	SQ FT	529.8								
RURAL	X7830070	GRV RCSD PVT MRKG 5	FOOT	20,110.0								
RURAL	X7830074	GRV RCSD PVT MRKG 7	FOOT	300.0								
RURAL	X7830076	GRV RCSD PVT MRKG 9	FOOT	0.0								
RURAL	X7830078	GRV RCSD PVT MRKG 13	FOOT	260.0								
RURAL	X7830090	GRV RCSD PVT MRKG 25	FOOT	235.0								
RURAL	78000100	THPL PVT MK LTR & SYM	SQ FT	529.8			23	2	4	2	0	0
RURAL	78000200	THLP PVT MK LINE 4	FOOT	20,110.0	9,600.0	10,510.0						
RURAL	78000400	THLP PVT MK LINE 6	FOOT	300.0	300.0	0.0						
RURAL	78000500	THLP PVT MK LINE 8	FOOT	0.0	0.0	0.0						
RURAL	78000600	THLP PVT MK LINE 12	FOOT	260.0	170.0	90.0						
RURAL	78000650	THLP PVT MK LINE 24	FOOT	235.0	235.0	0.0						
RURAL	78008300	POLYUREA PM T2 LTR-SY	SQ FT	0.0			0	0	0	0	0	0
RURAL	78008310	POLYUREA PM T2 LN 4	FOOT	0.0	0.0	0.0						
RURAL	78008330	POLYUREA PM T2 LN 6	FOOT	0.0	0.0	0.0						
RURAL	78008340	POLYUREA PM T2 LN 8	FOOT	0.0	0.0	0.0						
RURAL	78008350	POLYUREA PM T2 LN 12	FOOT	0.0	0.0	0.0						
RURAL	78008370	POLYUREA PM T2 LN 24	FOOT	0.0	0.0	0.0						

Location #8: Old US 51 & E 800 N RD

Urban/ Rural	Pay Item	Description	Unit	Quantity	White	Yellow	Lt/Rt Arrow	Wrong Way Arrow	Railroad "R"	Railroad "X"	Comb. Arrow	Straight Arrow
URBAN	X0327980	PAVT MARKING REMOVAL	SQ FT	0.0								
URBAN	X7830060	GRV RCSD PM LTR & SYM	SQ FT	0.0								
URBAN	X7830070	GRV RCSD PVT MRKG 5	FOOT	0.0								
URBAN	X7830074	GRV RCSD PVT MRKG 7	FOOT	0.0								
URBAN	X7830076	GRV RCSD PVT MRKG 9	FOOT	0.0								
URBAN	X7830078	GRV RCSD PVT MRKG 13	FOOT	0.0								
URBAN	X7830090	GRV RCSD PVT MRKG 25	FOOT	36.0								
URBAN	78000100	THPL PVT MK LTR & SYM	SQ FT	0.0			0	0	0	0	0	0
URBAN	78000200	THLP PVT MK LINE 4	FOOT	0.0	0.0	0.0						
URBAN	78000400	THLP PVT MK LINE 6	FOOT	0.0	0.0	0.0						
URBAN	78000500	THLP PVT MK LINE 8	FOOT	0.0	0.0	0.0						
URBAN	78000600	THLP PVT MK LINE 12	FOOT	0.0	0.0	0.0						
URBAN	78000650	THLP PVT MK LINE 24	FOOT	36.0	36.0	0.0						
URBAN	78008300	POLYUREA PM T2 LTR-SY	SQ FT	0.0			0	0	0	0	0	0
URBAN	78008310	POLYUREA PM T2 LN 4	FOOT	0.0	0.0	0.0						
URBAN	78008330	POLYUREA PM T2 LN 6	FOOT	0.0	0.0	0.0						
URBAN	78008340	POLYUREA PM T2 LN 8	FOOT	0.0	0.0	0.0						
URBAN	78008350	POLYUREA PM T2 LN 12	FOOT	0.0	0.0	0.0						
URBAN	78008370	POLYUREA PM T2 LN 24	FOOT	0.0	0.0	0.0						

MODEL: I:\MODEL\MHMF5
 FILE: MHMF5_Plan\Urban\comada.dwg
 PROJECT: D:\Projects\0546534\CADD\Drawings\Design\Backups\0546534-Int-5-Schedule.dgn

USER NAME = farnhamba	DESIGNED -	REVISED -
	DRAWN -	REVISED -
PLOT SCALE = 40.0000 ' / in.	CHECKED -	REVISED -
PLOT DATE = 10/15/2019	DATE -	REVISED -

**STATE OF ILLINOIS
DEPARTMENT OF TRANSPORTATION**

SCHEDULE OF QUANTITIES

SCALE: SHEET 11 OF 29 SHEETS STA. TO STA.

* DEWITT, MCLEAN, PIATT ** D-5HT PVMNT MRK RPR 20-22

F.A. RTE.	SECTION	COUNTY	TOTAL SHEETS	SHEET NO.
VAR	**	-	45	22
			CONTRACT NO. 46534	
		ILLINOIS FED. AID PROJECT		

MCLEAN COUNTY

Location #9: US 150 & George Evans Jr High School												
Urban/ Rural	Pay Item	Description	Unit	Quantity	White	Yellow	Lt/Rt Arrow	Wrong Way Arrow	Railroad "R"	Railroad "X"	Comb. Arrow	Straight Arrow
URBAN	X0327980	PAVT MARKING REMOVAL	SQ FT	0.0								
URBAN	X7830060	GRV RCSD PM LTR & SYM	SQ FT	187.2								
URBAN	X7830070	GRV RCSD PVT MRKG 5	FOOT	8,530.0								
URBAN	X7830074	GRV RCSD PVT MRKG 7	FOOT	0.0								
URBAN	X7830076	GRV RCSD PVT MRKG 9	FOOT	0.0								
URBAN	X7830078	GRV RCSD PVT MRKG 13	FOOT	300.0								
URBAN	X7830090	GRV RCSD PVT MRKG 25	FOOT	98.0								
URBAN	78000100	THPL PVT MK LTR & SYM	SQ FT	187.2			12	0	0	0	0	0
URBAN	78000200	THLP PVT MK LINE 4	FOOT	8,530.0	3,870.0	4,660.0						
URBAN	78000400	THLP PVT MK LINE 6	FOOT	0.0	0.0	0.0						
URBAN	78000500	THLP PVT MK LINE 8	FOOT	0.0	0.0	0.0						
URBAN	78000600	THLP PVT MK LINE 12	FOOT	300.0	90.0	210.0						
URBAN	78000650	THLP PVT MK LINE 24	FOOT	98.0	98.0	0.0						
URBAN	78008300	POLYUREA PM T2 LTR-SY	SQ FT	0.0			0	0	0	0	0	0
URBAN	78008310	POLYUREA PM T2 LN 4	FOOT	0.0	0.0	0.0						
URBAN	78008330	POLYUREA PM T2 LN 6	FOOT	0.0	0.0	0.0						
URBAN	78008340	POLYUREA PM T2 LN 8	FOOT	0.0	0.0	0.0						
URBAN	78008350	POLYUREA PM T2 LN 12	FOOT	0.0	0.0	0.0						
URBAN	78008370	POLYUREA PM T2 LN 24	FOOT	0.0	0.0	0.0						

Location #10: US 150 & Towanda Barnes Rd												
Urban/ Rural	Pay Item	Description	Unit	Quantity	White	Yellow	Lt/Rt Arrow	Wrong Way Arrow	Railroad "R"	Railroad "X"	Comb. Arrow	Straight Arrow
URBAN	X0327980	PAVT MARKING REMOVAL	SQ FT	0.0								
URBAN	X7830060	GRV RCSD PM LTR & SYM	SQ FT	93.6								
URBAN	X7830070	GRV RCSD PVT MRKG 5	FOOT	6,580.0								
URBAN	X7830074	GRV RCSD PVT MRKG 7	FOOT	530.0								
URBAN	X7830076	GRV RCSD PVT MRKG 9	FOOT	0.0								
URBAN	X7830078	GRV RCSD PVT MRKG 13	FOOT	415.0								
URBAN	X7830090	GRV RCSD PVT MRKG 25	FOOT	170.0								
URBAN	78000100	THPL PVT MK LTR & SYM	SQ FT	93.6			6	0	0	0	0	0
URBAN	78000200	THLP PVT MK LINE 4	FOOT	6,580.0	2,600.0	3,980.0						
URBAN	78000400	THLP PVT MK LINE 6	FOOT	530.0	530.0	0.0						
URBAN	78000500	THLP PVT MK LINE 8	FOOT	0.0	0.0	0.0						
URBAN	78000600	THLP PVT MK LINE 12	FOOT	415.0	195.0	220.0						
URBAN	78000650	THLP PVT MK LINE 24	FOOT	170.0	170.0	0.0						
URBAN	78008300	POLYUREA PM T2 LTR-SY	SQ FT	0.0			0	0	0	0	0	0
URBAN	78008310	POLYUREA PM T2 LN 4	FOOT	0.0	0.0	0.0						
URBAN	78008330	POLYUREA PM T2 LN 6	FOOT	0.0	0.0	0.0						
URBAN	78008340	POLYUREA PM T2 LN 8	FOOT	0.0	0.0	0.0						
URBAN	78008350	POLYUREA PM T2 LN 12	FOOT	0.0	0.0	0.0						
URBAN	78008370	POLYUREA PM T2 LN 24	FOOT	0.0	0.0	0.0						

MODEL: s:\MODEL\MHMF5
 FILE: mhmf5_pavt\pavt\mcomad.dwg
 PROJECT: D:\Projects\0546534\CADDData\Design\Backups\0546534-int-5-schedule.dgn

* DEWITT, MCLEAN, PIATT ** D-5HT PVMNT MRK RPR 20-22

USER NAME = farnhamba	DESIGNED -	REVISED -
	DRAWN -	REVISED -
PLOT SCALE = 40.0000 ' / in.	CHECKED -	REVISED -
PLOT DATE = 10/15/2019	DATE -	REVISED -

**STATE OF ILLINOIS
DEPARTMENT OF TRANSPORTATION**

SCHEDULE OF QUANTITIES

SCALE: SHEET 12 OF 29 SHEETS STA. TO STA.

F.A. RTE.	SECTION	COUNTY	TOTAL SHEETS	SHEET NO.
VAR	**	-	45	23
			CONTRACT NO. 46534	
		ILLINOIS FED. AID PROJECT		

MCLEAN COUNTY

Location #11: US 150 & Mallingham Way (1/2 miles East of Towanda Barnes Rd)

Urban/ Rural	Pay Item	Description	Unit	Quantity	White	Yellow	Lt/Rt Arrow	Wrong Way Arrow	Railroad "R"	Railroad "X"	Comb. Arrow	Straight Arrow
URBAN	X0327980	PAVT MARKING REMOVAL	SQ FT	0.0								
URBAN	X7830060	GRV RCSD PM LTR & SYM	SQ FT	31.2								
URBAN	X7830070	GRV RCSD PVT MRKG 5	FOOT	5,550.0								
URBAN	X7830074	GRV RCSD PVT MRKG 7	FOOT	0.0								
URBAN	X7830076	GRV RCSD PVT MRKG 9	FOOT	0.0								
URBAN	X7830078	GRV RCSD PVT MRKG 13	FOOT	190.0								
URBAN	X7830090	GRV RCSD PVT MRKG 25	FOOT	21.0								
URBAN	78000100	THPL PVT MK LTR & SYM	SQ FT	31.2			2	0	0	0	0	0
URBAN	78000200	THLP PVT MK LINE 4	FOOT	5,550.0	2,020.0	3,530.0						
URBAN	78000400	THLP PVT MK LINE 6	FOOT	0.0	0.0	0.0						
URBAN	78000500	THLP PVT MK LINE 8	FOOT	0.0	0.0	0.0						
URBAN	78000600	THLP PVT MK LINE 12	FOOT	190.0	0.0	190.0						
URBAN	78000650	THLP PVT MK LINE 24	FOOT	21.0	21.0	0.0						
URBAN	78008300	POLYUREA PM T2 LTR-SY	SQ FT	0.0			0	0	0	0	0	0
URBAN	78008310	POLYUREA PM T2 LN 4	FOOT	0.0	0.0	0.0						
URBAN	78008330	POLYUREA PM T2 LN 6	FOOT	0.0	0.0	0.0						
URBAN	78008340	POLYUREA PM T2 LN 8	FOOT	0.0	0.0	0.0						
URBAN	78008350	POLYUREA PM T2 LN 12	FOOT	0.0	0.0	0.0						
URBAN	78008370	POLYUREA PM T2 LN 24	FOOT	0.0	0.0	0.0						

Location #12: US 150 & N 2000 East RD

Urban/ Rural	Pay Item	Description	Unit	Quantity	White	Yellow	Lt/Rt Arrow	Wrong Way Arrow	Railroad "R"	Railroad "X"	Comb. Arrow	Straight Arrow
URBAN	X0327980	PAVT MARKING REMOVAL	SQ FT	0.0								
URBAN	X7830060	GRV RCSD PM LTR & SYM	SQ FT	78.0								
URBAN	X7830070	GRV RCSD PVT MRKG 5	FOOT	7,300.0								
URBAN	X7830074	GRV RCSD PVT MRKG 7	FOOT	0.0								
URBAN	X7830076	GRV RCSD PVT MRKG 9	FOOT	0.0								
URBAN	X7830078	GRV RCSD PVT MRKG 13	FOOT	195.0								
URBAN	X7830090	GRV RCSD PVT MRKG 25	FOOT	80.0								
URBAN	78000100	THPL PVT MK LTR & SYM	SQ FT	78.0			5	0	0	0	0	0
URBAN	78000200	THLP PVT MK LINE 4	FOOT	7,300.0	2,990.0	4,310.0						
URBAN	78000400	THLP PVT MK LINE 6	FOOT	0.0	0.0	0.0						
URBAN	78000500	THLP PVT MK LINE 8	FOOT	0.0	0.0	0.0						
URBAN	78000600	THLP PVT MK LINE 12	FOOT	195.0	0.0	195.0						
URBAN	78000650	THLP PVT MK LINE 24	FOOT	80.0	80.0	0.0						
URBAN	78008300	POLYUREA PM T2 LTR-SY	SQ FT	0.0			0	0	0	0	0	0
URBAN	78008310	POLYUREA PM T2 LN 4	FOOT	0.0	0.0	0.0						
URBAN	78008330	POLYUREA PM T2 LN 6	FOOT	0.0	0.0	0.0						
URBAN	78008340	POLYUREA PM T2 LN 8	FOOT	0.0	0.0	0.0						
URBAN	78008350	POLYUREA PM T2 LN 12	FOOT	0.0	0.0	0.0						
URBAN	78008370	POLYUREA PM T2 LN 24	FOOT	0.0	0.0	0.0						

MODEL: s:\MODEL\MHMS
 FILE: mhms_01.dwg
 PROJECT: D:\Projects\0546534\CADDData\Design\Backups\0546534-01-5-Schedule.dgn

* DEWITT, MCLEAN, PIATT ** D-SHT PVMNT MRK RPR 20-22

USER NAME = farnhamba DESIGNED - DRAWN - PLOT SCALE = 40.0000 ' / in. CHECKED - PLOT DATE = 10/15/2019 DATE -	REVISED - REVISED - REVISED - REVISED -	STATE OF ILLINOIS DEPARTMENT OF TRANSPORTATION	SCHEDULE OF QUANTITIES	F.A. RTE. VAR SECTION ** COUNTY - TOTAL SHEETS 45 SHEET NO. 24 CONTRACT NO. 46534	SCALE: SHEET 13 OF 29 SHEETS STA. TO STA. ILLINOIS FED. AID PROJECT
---	--	---	-------------------------------	--	--

MCLEAN COUNTY

Location #13: US 150 & Chestnut St in LeRoy												
Urban/ Rural	Pay Item	Description	Unit	Quantity	White	Yellow	Lt/Rt Arrow	Wrong Way Arrow	Railroad "R"	Railroad "X"	Comb. Arrow	Straight Arrow
RURAL	X0327980	PAVT MARKING REMOVAL	SQ FT	0.0								
RURAL	X7830060	GRV RCSD PM LTR & SYM	SQ FT	0.0								
RURAL	X7830070	GRV RCSD PVT MRKG 5	FOOT	0.0								
RURAL	X7830074	GRV RCSD PVT MRKG 7	FOOT	0.0								
RURAL	X7830076	GRV RCSD PVT MRKG 9	FOOT	0.0								
RURAL	X7830078	GRV RCSD PVT MRKG 13	FOOT	100.0								
RURAL	X7830090	GRV RCSD PVT MRKG 25	FOOT	100.0								
RURAL	78000100	THPL PVT MK LTR & SYM	SQ FT	0.0			0	0	0	0	0	0
RURAL	78000200	THLP PVT MK LINE 4	FOOT	0.0	0.0	0.0						
RURAL	78000400	THLP PVT MK LINE 6	FOOT	0.0	0.0	0.0						
RURAL	78000500	THLP PVT MK LINE 8	FOOT	0.0	0.0	0.0						
RURAL	78000600	THLP PVT MK LINE 12	FOOT	100.0	100.0	0.0						
RURAL	78000650	THLP PVT MK LINE 24	FOOT	100.0	100.0	0.0						
RURAL	78008300	POLYUREA PM T2 LTR-SY	SQ FT	0.0			0	0	0	0	0	0
RURAL	78008310	POLYUREA PM T2 LN 4	FOOT	0.0	0.0	0.0						
RURAL	78008330	POLYUREA PM T2 LN 6	FOOT	0.0	0.0	0.0						
RURAL	78008340	POLYUREA PM T2 LN 8	FOOT	0.0	0.0	0.0						
RURAL	78008350	POLYUREA PM T2 LN 12	FOOT	0.0	0.0	0.0						
RURAL	78008370	POLYUREA PM T2 LN 24	FOOT	0.0	0.0	0.0						

Location #14: IL 165 @ RR 2.6 miles West of Ford County Line												
Urban/ Rural	Pay Item	Description	Unit	Quantity	White	Yellow	Lt/Rt Arrow	Wrong Way Arrow	Railroad "R"	Railroad "X"	Comb. Arrow	Straight Arrow
RURAL	X0327980	PAVT MARKING REMOVAL	SQ FT	0.0								
RURAL	X7830060	GRV RCSD PM LTR & SYM	SQ FT	122.4								
RURAL	X7830070	GRV RCSD PVT MRKG 5	FOOT	0.0								
RURAL	X7830074	GRV RCSD PVT MRKG 7	FOOT	0.0								
RURAL	X7830076	GRV RCSD PVT MRKG 9	FOOT	0.0								
RURAL	X7830078	GRV RCSD PVT MRKG 13	FOOT	0.0								
RURAL	X7830090	GRV RCSD PVT MRKG 25	FOOT	72.0								
RURAL	78000100	THPL PVT MK LTR & SYM	SQ FT	122.4			0	0	4	2	0	0
RURAL	78000200	THLP PVT MK LINE 4	FOOT	0.0	0.0	0.0						
RURAL	78000400	THLP PVT MK LINE 6	FOOT	0.0	0.0	0.0						
RURAL	78000500	THLP PVT MK LINE 8	FOOT	0.0	0.0	0.0						
RURAL	78000600	THLP PVT MK LINE 12	FOOT	0.0	0.0	0.0						
RURAL	78000650	THLP PVT MK LINE 24	FOOT	72.0	72.0	0.0						
RURAL	78008300	POLYUREA PM T2 LTR-SY	SQ FT	0.0			0	0	0	0	0	0
RURAL	78008310	POLYUREA PM T2 LN 4	FOOT	0.0	0.0	0.0						
RURAL	78008330	POLYUREA PM T2 LN 6	FOOT	0.0	0.0	0.0						
RURAL	78008340	POLYUREA PM T2 LN 8	FOOT	0.0	0.0	0.0						
RURAL	78008350	POLYUREA PM T2 LN 12	FOOT	0.0	0.0	0.0						
RURAL	78008370	POLYUREA PM T2 LN 24	FOOT	0.0	0.0	0.0						

MODEL: s:\MODEL\MHMS
 FILE: mhms_20190801.dwg
 PROJECT: D:\Projects\2019\20190801\20190801.dwg
 OFFICE: D:\Projects\2019\20190801\20190801.dwg
 DESIGNED: D:\Projects\2019\20190801\20190801.dwg
 DRAWN: D:\Projects\2019\20190801\20190801.dwg
 CHECKED: D:\Projects\2019\20190801\20190801.dwg
 DATE: 10/15/2019

USER NAME = farnhamba	DESIGNED -	REVISED -
	DRAWN -	REVISED -
PLOT SCALE = 40.0000 ' / in.	CHECKED -	REVISED -
PLOT DATE = 10/15/2019	DATE -	REVISED -

**STATE OF ILLINOIS
DEPARTMENT OF TRANSPORTATION**

SCHEDULE OF QUANTITIES

SCALE: SHEET 14 OF 29 SHEETS STA. TO STA.

* DEWITT, MCLEAN, PIATT ** D-SHT PVMNT MRK RPR 20-22

F.A. RTE.	SECTION	COUNTY	TOTAL SHEETS	SHEET NO.
VAR	**	-	45	25
CONTRACT NO. 46534				
ILLINOIS FED. AID PROJECT				

MCLEAN COUNTY

Location #15: Old US 66 & Jefferson St in Towanda												
Urban/ Rural	Pay Item	Description	Unit	Quantity	White	Yellow	Lt/Rt Arrow	Wrong Way Arrow	Railroad "R"	Railroad "X"	Comb. Arrow	Straight Arrow
URBAN	X0327980	PAVT MARKING REMOVAL	SQ FT	40.0								
URBAN	X7830060	GRV RCSD PM LTR & SYM	SQ FT	0.0								
URBAN	X7830070	GRV RCSD PVT MRKG 5	FOOT	0.0								
URBAN	X7830074	GRV RCSD PVT MRKG 7	FOOT	0.0								
URBAN	X7830076	GRV RCSD PVT MRKG 9	FOOT	0.0								
URBAN	X7830078	GRV RCSD PVT MRKG 13	FOOT	0.0								
URBAN	X7830090	GRV RCSD PVT MRKG 25	FOOT	63.0								
URBAN	78000100	THPL PVT MK LTR & SYM	SQ FT	0.0			0	0	0	0	0	0
URBAN	78000200	THLP PVT MK LINE 4	FOOT	0.0	0.0	0.0						
URBAN	78000400	THLP PVT MK LINE 6	FOOT	0.0	0.0	0.0						
URBAN	78000500	THLP PVT MK LINE 8	FOOT	0.0	0.0	0.0						
URBAN	78000600	THLP PVT MK LINE 12	FOOT	0.0	0.0	0.0						
URBAN	78000650	THLP PVT MK LINE 24	FOOT	48.0	48.0	0.0						
URBAN	78008300	POLYUREA PM T2 LTR-SY	SQ FT	0.0			0	0	0	0	0	0
URBAN	78008310	POLYUREA PM T2 LN 4	FOOT	0.0	0.0	0.0						
URBAN	78008330	POLYUREA PM T2 LN 6	FOOT	0.0	0.0	0.0						
URBAN	78008340	POLYUREA PM T2 LN 8	FOOT	0.0	0.0	0.0						
URBAN	78008350	POLYUREA PM T2 LN 12	FOOT	0.0	0.0	0.0						
URBAN	78008370	POLYUREA PM T2 LN 24	FOOT	15.0	15.0	0.0						

Location #16: Old US 66 & Main St in Lexington												
Urban/ Rural	Pay Item	Description	Unit	Quantity	White	Yellow	Lt/Rt Arrow	Wrong Way Arrow	Railroad "R"	Railroad "X"	Comb. Arrow	Straight Arrow
RURAL	X0327980	PAVT MARKING REMOVAL	SQ FT	0.0								
RURAL	X7830060	GRV RCSD PM LTR & SYM	SQ FT	0.0								
RURAL	X7830070	GRV RCSD PVT MRKG 5	FOOT	0.0								
RURAL	X7830074	GRV RCSD PVT MRKG 7	FOOT	70.0								
RURAL	X7830076	GRV RCSD PVT MRKG 9	FOOT	0.0								
RURAL	X7830078	GRV RCSD PVT MRKG 13	FOOT	60.0								
RURAL	X7830090	GRV RCSD PVT MRKG 25	FOOT	70.0								
RURAL	78000100	THPL PVT MK LTR & SYM	SQ FT	0.0			0	0	0	0	0	0
RURAL	78000200	THLP PVT MK LINE 4	FOOT	0.0	0.0	0.0						
RURAL	78000400	THLP PVT MK LINE 6	FOOT	70.0	70.0	0.0						
RURAL	78000500	THLP PVT MK LINE 8	FOOT	0.0	0.0	0.0						
RURAL	78000600	THLP PVT MK LINE 12	FOOT	60.0	60.0	0.0						
RURAL	78000650	THLP PVT MK LINE 24	FOOT	70.0	70.0	0.0						
RURAL	78008300	POLYUREA PM T2 LTR-SY	SQ FT	0.0			0	0	0	0	0	0
RURAL	78008310	POLYUREA PM T2 LN 4	FOOT	0.0	0.0	0.0						
RURAL	78008330	POLYUREA PM T2 LN 6	FOOT	0.0	0.0	0.0						
RURAL	78008340	POLYUREA PM T2 LN 8	FOOT	0.0	0.0	0.0						
RURAL	78008350	POLYUREA PM T2 LN 12	FOOT	0.0	0.0	0.0						
RURAL	78008370	POLYUREA PM T2 LN 24	FOOT	0.0	0.0	0.0						

MODEL: I:\MODEL\MHMF5
 FILE: Mhmf5_Plan.dwg
 PROJECT: D:\Projects\0546534\CADDData\Design\Backups\0546534-Int-5-Schedule.dgn

USER NAME = farnhamba	DESIGNED -	REVISED -
	DRAWN -	REVISED -
PLOT SCALE = 40.0000 ' / in.	CHECKED -	REVISED -
PLOT DATE = 10/15/2019	DATE -	REVISED -

**STATE OF ILLINOIS
DEPARTMENT OF TRANSPORTATION**

SCHEDULE OF QUANTITIES

SCALE: SHEET 15 OF 29 SHEETS STA. TO STA.

* DEWITT, MCLEAN, PIATT ** D-5HT PVMNT MRK RPR 20-22

F.A. RTE.	SECTION	COUNTY	TOTAL SHEETS	SHEET NO.
VAR	**	-	45	26
			CONTRACT NO. 46534	
		ILLINOIS FED. AID PROJECT		

MCLEAN COUNTY

Location #17: US 24 from I-55 to Old US 66 in Chenoa														
Urban/ Rural	Pay Item	Description	Unit	Quantity	White	Yellow	Lt/Rt Arrow	Wrong Way Arrow	Railroad "R"	Railroad "X"	Comb. Arrow	Straight Arrow	"BIKE"	"XING"
RURAL	X0327980	PAVT MARKING REMOVAL	SQ FT	0.0										
RURAL	X7830060	GRV RCSD PM LTR & SYM	SQ FT	569.7										
RURAL	X7830070	GRV RCSD PVT MRKG 5	FOOT	17,950.0										
RURAL	X7830074	GRV RCSD PVT MRKG 7	FOOT	950.0										
RURAL	X7830076	GRV RCSD PVT MRKG 9	FOOT	0.0										
RURAL	X7830078	GRV RCSD PVT MRKG 13	FOOT	1,010.0										
RURAL	X7830090	GRV RCSD PVT MRKG 25	FOOT	254.0										
RURAL	78000100	THPL PVT MK LTR & SYM	SQ FT	569.7			29	2	0	0	0	0	3	3
RURAL	78000200	THLP PVT MK LINE 4	FOOT	17,950.0	11,900.0	6,050.0								
RURAL	78000400	THLP PVT MK LINE 6	FOOT	950.0	950.0	0.0								
RURAL	78000500	THLP PVT MK LINE 8	FOOT	0.0	0.0	0.0								
RURAL	78000600	THLP PVT MK LINE 12	FOOT	1,010.0	660.0	350.0								
RURAL	78000650	THLP PVT MK LINE 24	FOOT	254.0	254.0	0.0								
RURAL	78008300	POLYUREA PM T2 LTR-SY	SQ FT	0.0			0	0	0	0	0	0		
RURAL	78008310	POLYUREA PM T2 LN 4	FOOT	0.0	0.0	0.0								
RURAL	78008330	POLYUREA PM T2 LN 6	FOOT	0.0	0.0	0.0								
RURAL	78008340	POLYUREA PM T2 LN 8	FOOT	0.0	0.0	0.0								
RURAL	78008350	POLYUREA PM T2 LN 12	FOOT	0.0	0.0	0.0								
RURAL	78008370	POLYUREA PM T2 LN 24	FOOT	0.0	0.0	0.0								

Location #18: US 24 @ RR in Chenoa														
Urban/ Rural	Pay Item	Description	Unit	Quantity	White	Yellow	Lt/Rt Arrow	Wrong Way Arrow	Railroad "R"	Railroad "X"	Comb. Arrow	Straight Arrow		
RURAL	X0327980	PAVT MARKING REMOVAL	SQ FT	0.0										
RURAL	X7830060	GRV RCSD PM LTR & SYM	SQ FT	122.4										
RURAL	X7830070	GRV RCSD PVT MRKG 5	FOOT	0.0										
RURAL	X7830074	GRV RCSD PVT MRKG 7	FOOT	0.0										
RURAL	X7830076	GRV RCSD PVT MRKG 9	FOOT	0.0										
RURAL	X7830078	GRV RCSD PVT MRKG 13	FOOT	26.0										
RURAL	X7830090	GRV RCSD PVT MRKG 25	FOOT	52.0										
RURAL	78000100	THPL PVT MK LTR & SYM	SQ FT	61.2			0	0	2	1	0	0		
RURAL	78000200	THLP PVT MK LINE 4	FOOT	0.0	0.0	0.0								
RURAL	78000400	THLP PVT MK LINE 6	FOOT	0.0	0.0	0.0								
RURAL	78000500	THLP PVT MK LINE 8	FOOT	0.0	0.0	0.0								
RURAL	78000600	THLP PVT MK LINE 12	FOOT	0.0	0.0	0.0								
RURAL	78000650	THLP PVT MK LINE 24	FOOT	52.0	52.0	0.0								
RURAL	78008300	POLYUREA PM T2 LTR-SY	SQ FT	61.2			0	0	2	1	0	0		
RURAL	78008310	POLYUREA PM T2 LN 4	FOOT	0.0	0.0	0.0								
RURAL	78008330	POLYUREA PM T2 LN 6	FOOT	0.0	0.0	0.0								
RURAL	78008340	POLYUREA PM T2 LN 8	FOOT	0.0	0.0	0.0								
RURAL	78008350	POLYUREA PM T2 LN 12	FOOT	26.0	26.0	0.0								
RURAL	78008370	POLYUREA PM T2 LN 24	FOOT	0.0	0.0	0.0								

MODEL: I:\MODEL\MMF5
 FILE: MMF5_Plan\pdm\mmoma.dwg
 PROJECT: D:\Projects\0546534\CADD\Drawings\Design\Backups\0546534-int-5chedule.dgn

* DEWITT, MCLEAN, PIATT ** D-SHT PVMNT MRK RPR 20-22

USER NAME = farnhamba	DESIGNED -	REVISED -
	DRAWN -	REVISED -
PLOT SCALE = 40.0000 ' / in.	CHECKED -	REVISED -
PLOT DATE = 10/15/2019	DATE -	REVISED -

**STATE OF ILLINOIS
DEPARTMENT OF TRANSPORTATION**

SCHEDULE OF QUANTITIES

SCALE: SHEET 16 OF 29 SHEETS STA. TO STA.

F.A. RTE.	SECTION	COUNTY	TOTAL SHEETS	SHEET NO.
VAR	**	-	45	27
			CONTRACT NO. 46534	
		ILLINOIS FED. AID PROJECT		

MCLEAN COUNTY

Location #19: Old US 66 @ RR in Chenoa

Urban/ Rural	Pay Item	Description	Unit	Quantity	White	Yellow	Lt/Rt Arrow	Wrong Way Arrow	Railroad "R"	Railroad "X"	Comb. Arrow	Straight Arrow
RURAL	X0327980	PAVT MARKING REMOVAL	SQ FT	0.0								
RURAL	X7830060	GRV RCSD PM LTR & SYM	SQ FT	122.4								
RURAL	X7830070	GRV RCSD PVT MRKG 5	FOOT	0.0								
RURAL	X7830074	GRV RCSD PVT MRKG 7	FOOT	0.0								
RURAL	X7830076	GRV RCSD PVT MRKG 9	FOOT	0.0								
RURAL	X7830078	GRV RCSD PVT MRKG 13	FOOT	0.0								
RURAL	X7830090	GRV RCSD PVT MRKG 25	FOOT	66.0								
RURAL	78000100	THPL PVT MK LTR & SYM	SQ FT	122.4			0	0	4	2	0	0
RURAL	78000200	THLP PVT MK LINE 4	FOOT	0.0	0.0	0.0						
RURAL	78000400	THLP PVT MK LINE 6	FOOT	0.0	0.0	0.0						
RURAL	78000500	THLP PVT MK LINE 8	FOOT	0.0	0.0	0.0						
RURAL	78000600	THLP PVT MK LINE 12	FOOT	0.0	0.0	0.0						
RURAL	78000650	THLP PVT MK LINE 24	FOOT	66.0	66.0	0.0						
RURAL	78008300	POLYUREA PM T2 LTR-SY	SQ FT	0.0			0	0	0	0	0	0
RURAL	78008310	POLYUREA PM T2 LN 4	FOOT	0.0	0.0	0.0						
RURAL	78008330	POLYUREA PM T2 LN 6	FOOT	0.0	0.0	0.0						
RURAL	78008340	POLYUREA PM T2 LN 8	FOOT	0.0	0.0	0.0						
RURAL	78008350	POLYUREA PM T2 LN 12	FOOT	0.0	0.0	0.0						
RURAL	78008370	POLYUREA PM T2 LN 24	FOOT	0.0	0.0	0.0						

Location #20: IL 251 @ I-39

Urban/ Rural	Pay Item	Description	Unit	Quantity	White	Yellow	Lt/Rt Arrow	Wrong Way Arrow	Railroad "R"	Railroad "X"	Comb. Arrow	Straight Arrow
RURAL	X0327980	PAVT MARKING REMOVAL	SQ FT	15.6								
RURAL	X7830060	GRV RCSD PM LTR & SYM	SQ FT	204.6								
RURAL	X7830070	GRV RCSD PVT MRKG 5	FOOT	11,610.0								
RURAL	X7830074	GRV RCSD PVT MRKG 7	FOOT	0.0								
RURAL	X7830076	GRV RCSD PVT MRKG 9	FOOT	0.0								
RURAL	X7830078	GRV RCSD PVT MRKG 13	FOOT	30.0								
RURAL	X7830090	GRV RCSD PVT MRKG 25	FOOT	96.0								
RURAL	78000100	THPL PVT MK LTR & SYM	SQ FT	204.6			10	2	0	0	0	0
RURAL	78000200	THLP PVT MK LINE 4	FOOT	9,500.0	4,900.0	4,600.0						
RURAL	78000400	THLP PVT MK LINE 6	FOOT	0.0	0.0	0.0						
RURAL	78000500	THLP PVT MK LINE 8	FOOT	0.0	0.0	0.0						
RURAL	78000600	THLP PVT MK LINE 12	FOOT	30.0	30.0	0.0						
RURAL	78000650	THLP PVT MK LINE 24	FOOT	0.0	0.0	0.0						
RURAL	78008300	POLYUREA PM T2 LTR-SY	SQ FT	0.0			0	0	0	0	0	0
RURAL	78008310	POLYUREA PM T2 LN 4	FOOT	2,110.0	1,190.0	920.0						
RURAL	78008330	POLYUREA PM T2 LN 6	FOOT	0.0	0.0	0.0						
RURAL	78008340	POLYUREA PM T2 LN 8	FOOT	0.0	0.0	0.0						
RURAL	78008350	POLYUREA PM T2 LN 12	FOOT	0.0	0.0	0.0						
RURAL	78008370	POLYUREA PM T2 LN 24	FOOT	96.0	96.0	0.0						

MODEL: s:\MODEL\MHMS
 FILE: mhms_e_pavt\pavt\mcomada.dwg
 PROJECT: D:\Projects\0546534\CADDData\Design\Backups\0546534-ent-5\chenua.dgn

* DEWITT, MCLEAN, PIATT ** D-5HT PVMNT MRK RPR 20-22

USER NAME = farnhamba	DESIGNED -	REVISED -
	DRAWN -	REVISED -
PLOT SCALE = 40.0000 ' / in.	CHECKED -	REVISED -
PLOT DATE = 10/15/2019	DATE -	REVISED -

**STATE OF ILLINOIS
DEPARTMENT OF TRANSPORTATION**

SCHEDULE OF QUANTITIES

SCALE: SHEET 17 OF 29 SHEETS STA. TO STA.

F.A. RTE.	SECTION	COUNTY	TOTAL SHEETS	SHEET NO.
VAR	**	-	45	28

CONTRACT NO. 46534

ILLINOIS FED. AID PROJECT

MCLEAN COUNTY

Location #21: IL 9 & IL 122												
Urban/ Rural	Pay Item	Description	Unit	Quantity	White	Yellow	Lt/Rt Arrow	Wrong Way Arrow	Railroad "R"	Railroad "X"	Comb. Arrow	Straight Arrow
RURAL	X0327980	PAVT MARKING REMOVAL	SQ FT	0.0								
RURAL	X7830060	GRV RCSD PM LTR & SYM	SQ FT	0.0								
RURAL	X7830070	GRV RCSD PVT MRKG 5	FOOT	700.0								
RURAL	X7830074	GRV RCSD PVT MRKG 7	FOOT	400.0								
RURAL	X7830076	GRV RCSD PVT MRKG 9	FOOT	0.0								
RURAL	X7830078	GRV RCSD PVT MRKG 13	FOOT	100.0								
RURAL	X7830090	GRV RCSD PVT MRKG 25	FOOT	40.0								
RURAL	78000100	THPL PVT MK LTR & SYM	SQ FT	0.0			0	0	0	0	0	0
RURAL	78000200	THLP PVT MK LINE 4	FOOT	700.0	700.0	0.0						
RURAL	78000400	THLP PVT MK LINE 6	FOOT	400.0	400.0	0.0						
RURAL	78000500	THLP PVT MK LINE 8	FOOT	0.0	0.0	0.0						
RURAL	78000600	THLP PVT MK LINE 12	FOOT	100.0	100.0	0.0						
RURAL	78000650	THLP PVT MK LINE 24	FOOT	40.0	40.0	0.0						
RURAL	78008300	POLYUREA PM T2 LTR-SY	SQ FT	0.0			0	0	0	0	0	0
RURAL	78008310	POLYUREA PM T2 LN 4	FOOT	0.0	0.0	0.0						
RURAL	78008330	POLYUREA PM T2 LN 6	FOOT	0.0	0.0	0.0						
RURAL	78008340	POLYUREA PM T2 LN 8	FOOT	0.0	0.0	0.0						
RURAL	78008350	POLYUREA PM T2 LN 12	FOOT	0.0	0.0	0.0						
RURAL	78008370	POLYUREA PM T2 LN 24	FOOT	0.0	0.0	0.0						

Location #22: IL 9 & Covell Rd (West of Bloomington)												
Urban/ Rural	Pay Item	Description	Unit	Quantity	White	Yellow	Lt/Rt Arrow	Wrong Way Arrow	Railroad "R"	Railroad "X"	Comb. Arrow	Straight Arrow
URBAN	X0327980	PAVT MARKING REMOVAL	SQ FT	0.0								
URBAN	X7830060	GRV RCSD PM LTR & SYM	SQ FT	62.4								
URBAN	X7830070	GRV RCSD PVT MRKG 5	FOOT	7,060.0								
URBAN	X7830074	GRV RCSD PVT MRKG 7	FOOT	0.0								
URBAN	X7830076	GRV RCSD PVT MRKG 9	FOOT	0.0								
URBAN	X7830078	GRV RCSD PVT MRKG 13	FOOT	250.0								
URBAN	X7830090	GRV RCSD PVT MRKG 25	FOOT	100.0								
URBAN	78000100	THPL PVT MK LTR & SYM	SQ FT	62.4			4	0	0	0	0	0
URBAN	78000200	THLP PVT MK LINE 4	FOOT	7,060.0	2,760.0	4,300.0						
URBAN	78000400	THLP PVT MK LINE 6	FOOT	0.0	0.0	0.0						
URBAN	78000500	THLP PVT MK LINE 8	FOOT	0.0	0.0	0.0						
URBAN	78000600	THLP PVT MK LINE 12	FOOT	250.0	250.0	0.0						
URBAN	78000650	THLP PVT MK LINE 24	FOOT	100.0	100.0	0.0						
URBAN	78008300	POLYUREA PM T2 LTR-SY	SQ FT	0.0			0	0	0	0	0	0
URBAN	78008310	POLYUREA PM T2 LN 4	FOOT	0.0	0.0	0.0						
URBAN	78008330	POLYUREA PM T2 LN 6	FOOT	0.0	0.0	0.0						
URBAN	78008340	POLYUREA PM T2 LN 8	FOOT	0.0	0.0	0.0						
URBAN	78008350	POLYUREA PM T2 LN 12	FOOT	0.0	0.0	0.0						
URBAN	78008370	POLYUREA PM T2 LN 24	FOOT	0.0	0.0	0.0						

MODEL: s:\MODEL\MHMS
 FILE: hamba_pvt.dwg
 PROJECT: D:\Projects\0546534\CADDData\Design\Backups\0546534-int-5chedule.dgn

USER NAME = farnhamba	DESIGNED -	REVISED -
	DRAWN -	REVISED -
PLOT SCALE = 40.0000 ' / in.	CHECKED -	REVISED -
PLOT DATE = 10/15/2019	DATE -	REVISED -

**STATE OF ILLINOIS
DEPARTMENT OF TRANSPORTATION**

SCHEDULE OF QUANTITIES

SCALE: SHEET 18 OF 29 SHEETS STA. TO STA.

* DEWITT, MCLEAN, PIATT ** D-SHT PVMNT MRK RPR 20-22

F.A. RTE.	SECTION	COUNTY	TOTAL SHEETS	SHEET NO.
VAR	**	-	45	29
			CONTRACT NO. 46534	
		ILLINOIS FED. AID PROJECT		

MCLEAN COUNTY

Location #23: IL 9 & Fox Hills Dr (West of Bloomington)												
Urban/ Rural	Pay Item	Description	Unit	Quantity	White	Yellow	Lt/Rt Arrow	Wrong Way Arrow	Railroad "R"	Railroad "X"	Comb. Arrow	Straight Arrow
URBAN	X0327980	PAVT MARKING REMOVAL	SQ FT	0.0								
URBAN	X7830060	GRV RCSD PM LTR & SYM	SQ FT	46.8								
URBAN	X7830070	GRV RCSD PVT MRKG 5	FOOT	600.0								
URBAN	X7830074	GRV RCSD PVT MRKG 7	FOOT	0.0								
URBAN	X7830076	GRV RCSD PVT MRKG 9	FOOT	0.0								
URBAN	X7830078	GRV RCSD PVT MRKG 13	FOOT	0.0								
URBAN	X7830090	GRV RCSD PVT MRKG 25	FOOT	0.0								
URBAN	78000100	THPL PVT MK LTR & SYM	SQ FT	46.8			3	0	0	0	0	0
URBAN	78000200	THLP PVT MK LINE 4	FOOT	600.0	600.0	0.0						
URBAN	78000400	THLP PVT MK LINE 6	FOOT	0.0	0.0	0.0						
URBAN	78000500	THLP PVT MK LINE 8	FOOT	0.0	0.0	0.0						
URBAN	78000600	THLP PVT MK LINE 12	FOOT	0.0	0.0	0.0						
URBAN	78000650	THLP PVT MK LINE 24	FOOT	0.0	0.0	0.0						
URBAN	78008300	POLYUREA PM T2 LTR-SY	SQ FT	0.0			0	0	0	0	0	0
URBAN	78008310	POLYUREA PM T2 LN 4	FOOT	0.0	0.0	0.0						
URBAN	78008330	POLYUREA PM T2 LN 6	FOOT	0.0	0.0	0.0						
URBAN	78008340	POLYUREA PM T2 LN 8	FOOT	0.0	0.0	0.0						
URBAN	78008350	POLYUREA PM T2 LN 12	FOOT	0.0	0.0	0.0						
URBAN	78008370	POLYUREA PM T2 LN 24	FOOT	0.0	0.0	0.0						

MODEL: I:\MODEL\NAMES
FILE: Names_Plan\Illum\comada.dwg; I:\Illinois\gov\PI\DOT\Documents\DOT_Offices\Illin\ct 5\Project\0546534\CADD\Drawn\Design\Backups\0546534-Int-Schedule.dgn

* DEWITT, MCLEAN, PIATT ** D-SHT PVMNT MRK RPR 20-22

USER NAME = farnhamba	DESIGNED -	REVISED -
	DRAWN -	REVISED -
PLOT SCALE = 40.0000 ' / in.	CHECKED -	REVISED -
PLOT DATE = 10/15/2019	DATE -	REVISED -

**STATE OF ILLINOIS
DEPARTMENT OF TRANSPORTATION**

SCHEDULE OF QUANTITIES

SCALE: SHEET 19 OF 29 SHEETS STA. TO STA.

F.A. RTE.	SECTION	COUNTY	TOTAL SHEETS	SHEET NO.
VAR	**	-	45	30
CONTRACT NO. 46534				
ILLINOIS FED. AID PROJECT				

MCLEAN COUNTY

Location #24: US 150 Mitsubishi Motorway from IL 9 to I-74

Urban/ Rural	Pay Item	Description	Unit	Quantity	White	Yellow	Lt/Rt Arrow	Wrong Way Arrow	Railroad "R"	Railroad "X"	Comb. Arrow	Straight Arrow
RURAL	X0327980	PAVT MARKING REMOVAL	SQ FT	0.0	0.0	0.0						
URBAN	X0327980	PAVT MARKING REMOVAL	SQ FT	0.0	0.0	0.0						
RURAL	X7830060	GRV RCSD PM LTR & SYM	SQ FT	244.3								
URBAN	X7830060	GRV RCSD PM LTR & SYM	SQ FT	1,192.7								
RURAL	X7830070	GRV RCSD PVT MRKG 5	FOOT	18,513.0								
URBAN	X7830070	GRV RCSD PVT MRKG 5	FOOT	90,387.0								
RURAL	X7830074	GRV RCSD PVT MRKG 7	FOOT	365.5								
URBAN	X7830074	GRV RCSD PVT MRKG 7	FOOT	1,784.5								
RURAL	X7830076	GRV RCSD PVT MRKG 9	FOOT	0.0								
URBAN	X7830076	GRV RCSD PVT MRKG 9	FOOT	0.0								
RURAL	X7830078	GRV RCSD PVT MRKG 13	FOOT	214.2								
URBAN	X7830078	GRV RCSD PVT MRKG 13	FOOT	1,045.8								
RURAL	X7830090	GRV RCSD PVT MRKG 25	FOOT	127.5								
URBAN	X7830090	GRV RCSD PVT MRKG 25	FOOT	622.5								
RURAL	78000100	THPL PVT MK LTR & SYM	SQ FT	274.0			14	2	0	0	0	0
URBAN	78000100	THPL PVT MK LTR & SYM	SQ FT	1,100.6			71	0	0	0	0	0
RURAL	78000200	THLP PVT MK LINE 4	FOOT	17,680.0	10,200.0	7,480.0						
URBAN	78000200	THLP PVT MK LINE 4	FOOT	86,320.0	49,800.0	36,520.0						
RURAL	78000400	THLP PVT MK LINE 6	FOOT	365.5	365.5	0.0						
URBAN	78000400	THLP PVT MK LINE 6	FOOT	1,784.5	1,784.5	0.0						
RURAL	78000500	THLP PVT MK LINE 8	FOOT	0.0	0.0	0.0						
URBAN	78000500	THLP PVT MK LINE 8	FOOT	0.0	0.0	0.0						
RURAL	78000600	THLP PVT MK LINE 12	FOOT	214.2	214.2	0.0						
URBAN	78000600	THLP PVT MK LINE 12	FOOT	1,045.8	1,045.8	0.0						
RURAL	78000650	THLP PVT MK LINE 24	FOOT	127.5	127.5	0.0						
URBAN	78000650	THLP PVT MK LINE 24	FOOT	622.5	622.5	0.0						
RURAL	78008300	POLYUREA PM T2 LTR-SY	SQ FT	0.0			0	0	0	0	0	0
URBAN	78008300	POLYUREA PM T2 LTR-SY	SQ FT	62.4			4	0	0	0	0	0
RURAL	78008310	POLYUREA PM T2 LN 4	FOOT	833.0	459.0	374.0						
URBAN	78008310	POLYUREA PM T2 LN 4	FOOT	4,067.0	2,241.0	1,826.0						
RURAL	78008330	POLYUREA PM T2 LN 6	FOOT	0.0	0.0	0.0						
URBAN	78008330	POLYUREA PM T2 LN 6	FOOT	0.0	0.0	0.0						
RURAL	78008340	POLYUREA PM T2 LN 8	FOOT	0.0	0.0	0.0						
URBAN	78008340	POLYUREA PM T2 LN 8	FOOT	0.0	0.0	0.0						
RURAL	78008350	POLYUREA PM T2 LN 12	FOOT	0.0	0.0	0.0						
URBAN	78008350	POLYUREA PM T2 LN 12	FOOT	0.0	0.0	0.0						
RURAL	78008370	POLYUREA PM T2 LN 24	FOOT	0.0	0.0	0.0						
URBAN	78008370	POLYUREA PM T2 LN 24	FOOT	0.0	0.0	0.0						

MODEL: 4-MODEL\MHFS
FILE: mhfs:pub\pdm\com\ada\illinois.gov\PWIDOT\Documents\DOT_Offices\Illinotc_5\Projects\0546534\CADDData\Design\Backups\0546534-int-5chedule.dgn

USER NAME = farnhamba	DESIGNED -	REVISED -
	DRAWN -	REVISED -
PLOT SCALE = 40.0000 ' / in.	CHECKED -	REVISED -
PLOT DATE = 10/15/2019	DATE -	REVISED -

**STATE OF ILLINOIS
DEPARTMENT OF TRANSPORTATION**

SCHEDULE OF QUANTITIES

SCALE: SHEET 20 OF 29 SHEETS STA. TO STA.

* DEWITT, MCLEAN, PIATT ** D-5HT PVMNT MRK RPR 20-22

F.A. RTE.	SECTION	COUNTY	TOTAL SHEETS	SHEET NO.
VAR	**	-	45	31
			CONTRACT NO. 46534	
			ILLINOIS FED. AID PROJECT	

MCLEAN COUNTY

Location #25: NB & SB Bus US 51 from Woodrig Rd to Raab Rd

Urban/ Rural	Pay Item	Description	Unit	Quantity	White	Yellow	Lt/Rt Arrow	Wrong Way Arrow	Railroad "R"	Railroad "X"	Comb. Arrow	Straight Arrow
URBAN	X0327980	PAVT MARKING REMOVAL	SQ FT	0.0								
URBAN	X7830060	GRV RCSD PM LTR & SYM	SQ FT	5,252.5								
URBAN	X7830070	GRV RCSD PVT MRKG 5	FOOT	49,450.0								
URBAN	X7830074	GRV RCSD PVT MRKG 7	FOOT	1,760.0								
URBAN	X7830076	GRV RCSD PVT MRKG 9	FOOT	0.0								
URBAN	X7830078	GRV RCSD PVT MRKG 13	FOOT	975.0								
URBAN	X7830090	GRV RCSD PVT MRKG 25	FOOT	4,160.0								
URBAN	78000100	THPL PVT MK LTR & SYM	SQ FT	5,174.5			195	0	0	0	40	95
URBAN	78000200	THLP PVT MK LINE 4	FOOT	49,000.0	32,500.0	16,500.0						
URBAN	78000400	THLP PVT MK LINE 6	FOOT	1,700.0	1,700.0	0.0						
URBAN	78000500	THLP PVT MK LINE 8	FOOT	0.0	0.0	0.0						
URBAN	78000600	THLP PVT MK LINE 12	FOOT	950.0	650.0	300.0						
URBAN	78000650	THLP PVT MK LINE 24	FOOT	4,100.0	4,100.0	0.0						
URBAN	78008300	POLYUREA PM T2 LTR-SY	SQ FT	78.0			5	0	0	0	0	0
URBAN	78008310	POLYUREA PM T2 LN 4	FOOT	450.0	450.0	0.0						
URBAN	78008330	POLYUREA PM T2 LN 6	FOOT	60.0	60.0	0.0						
URBAN	78008340	POLYUREA PM T2 LN 8	FOOT	0.0	0.0	0.0						
URBAN	78008350	POLYUREA PM T2 LN 12	FOOT	25.0	25.0	0.0						
URBAN	78008370	POLYUREA PM T2 LN 24	FOOT	60.0	60.0	0.0						

Location #26: Bus US 51 from Raab Rd to I-39

Urban/ Rural	Pay Item	Description	Unit	Quantity	White	Yellow	Lt/Rt Arrow	Wrong Way Arrow	Railroad "R"	Railroad "X"	Comb. Arrow	Straight Arrow
URBAN	X0327980	PAVT MARKING REMOVAL	SQ FT	500.0								
URBAN	X7830060	GRV RCSD PM LTR & SYM	SQ FT	1,579.2								
URBAN	X7830070	GRV RCSD PVT MRKG 5	FOOT	67,100.0								
URBAN	X7830074	GRV RCSD PVT MRKG 7	FOOT	2,100.0								
URBAN	X7830076	GRV RCSD PVT MRKG 9	FOOT	1,000.0								
URBAN	X7830078	GRV RCSD PVT MRKG 13	FOOT	1,170.0								
URBAN	X7830090	GRV RCSD PVT MRKG 25	FOOT	730.0								
URBAN	78000100	THPL PVT MK LTR & SYM	SQ FT	0.0			0	0	0	0	0	0
URBAN	78000200	THLP PVT MK LINE 4	FOOT	0.0	0.0	0.0						
URBAN	78000400	THLP PVT MK LINE 6	FOOT	0.0	0.0	0.0						
URBAN	78000500	THLP PVT MK LINE 8	FOOT	0.0	0.0	0.0						
URBAN	78000600	THLP PVT MK LINE 12	FOOT	0.0	0.0	0.0						
URBAN	78000650	THLP PVT MK LINE 24	FOOT	0.0	0.0	0.0						
URBAN	78008300	POLYUREA PM T2 LTR-SY	SQ FT	1,579.2			95	4	0	0	0	0
URBAN	78008310	POLYUREA PM T2 LN 4	FOOT	67,100.0	37,500.0	29,600.0						
URBAN	78008330	POLYUREA PM T2 LN 6	FOOT	2,100.0	2,100.0	0.0						
URBAN	78008340	POLYUREA PM T2 LN 8	FOOT	1,000.0	1,000.0	0.0						
URBAN	78008350	POLYUREA PM T2 LN 12	FOOT	1,170.0	1,050.0	120.0						
URBAN	78008370	POLYUREA PM T2 LN 24	FOOT	730.0	730.0	0.0						

MODEL: s:\MODEL\MHMS
FILE: mhms_20190909.dwg
PROJECT: D:\Projects\46534\CADD\Drawings\Design\Backups\46534-21-5-Schedule.dgn

USER NAME = farnhamba	DESIGNED -	REVISED -
	DRAWN -	REVISED -
PLOT SCALE = 40.0000 ' / in.	CHECKED -	REVISED -
PLOT DATE = 10/15/2019	DATE -	REVISED -

**STATE OF ILLINOIS
DEPARTMENT OF TRANSPORTATION**

SCHEDULE OF QUANTITIES

SCALE: SHEET 21 OF 29 SHEETS STA. TO STA.

* DEWITT, MCLEAN, PIATT ** D-SHT PVMNT MRK RPR 20-22

F.A. RTE.	SECTION	COUNTY	TOTAL SHEETS	SHEET NO.
VAR	**	-	45	32
CONTRACT NO. 46534				
		ILLINOIS	FED. AID PROJECT	

MCLEAN COUNTY

Location #27: US 150/IL 9 from Truckers Lane to Walton Drive															
Urban/ Rural	Pay Item	Description	Unit	Quantity	White	Yellow	Lt/Rt Arrow	Wrong Way Arrow	Railroad "R"	Railroad "X"	Comb. Arrow	Straight Arrow	"BIKE"	"XING"	Lane Drop Arrow
URBAN	X0327980	PAVT MARKING REMOVAL	SQ FT	0.0											
URBAN	X7830060	GRV RCSD PM LTR & SYM	SQ FT	665.4											
URBAN	X7830070	GRV RCSD PVT MRKG 5	FOOT	31,000.0											
URBAN	X7830074	GRV RCSD PVT MRKG 7	FOOT	800.0											
URBAN	X7830076	GRV RCSD PVT MRKG 9	FOOT	1,920.0											
URBAN	X7830078	GRV RCSD PVT MRKG 13	FOOT	1,580.0											
URBAN	X7830090	GRV RCSD PVT MRKG 25	FOOT	890.0											
URBAN	78000100	THPL PVT MK LTR & SYM	SQ FT	0.0			0	0	0	0	0	0			
URBAN	78000200	THLP PVT MK LINE 4	FOOT	0.0	0.0	0.0									
URBAN	78000400	THLP PVT MK LINE 6	FOOT	0.0	0.0	0.0									
URBAN	78000500	THLP PVT MK LINE 8	FOOT	0.0	0.0	0.0									
URBAN	78000600	THLP PVT MK LINE 12	FOOT	0.0	0.0	0.0									
URBAN	78000650	THLP PVT MK LINE 24	FOOT	0.0	0.0	0.0									
URBAN	78008300	POLYUREA PM T2 LTR-SY	SQ FT	665.4			34	0	0	0	2	0			2
URBAN	78008310	POLYUREA PM T2 LN 4	FOOT	31,000.0	17,800.0	13,200.0									
URBAN	78008330	POLYUREA PM T2 LN 6	FOOT	800.0	800.0	0.0									
URBAN	78008340	POLYUREA PM T2 LN 8	FOOT	1,920.0	1,920.0	0.0									
URBAN	78008350	POLYUREA PM T2 LN 12	FOOT	1,580.0	980.0	600.0									
URBAN	78008370	POLYUREA PM T2 LN 24	FOOT	890.0	890.0	0.0									

McLean County Totals:																	
	Pay Item	Description	Unit	Urban	Rural	Quantity	White	Yellow	Lt/Rt Arrow	Wrong Way Arrow	Railroad "R"	Railroad "X"	Comb. Arrow	Straight Arrow	"BIKE"	"XING"	Lane Drop Arrow
	X0327980	PAVT MARKING REMOVAL	SQ FT	540.0	282.0	822.0											
	X7830060	GRV RCSD PM LTR & SYM	SQ FT	9,189.0	2,770.6	11,959.6											
	X7830070	GRV RCSD PVT MRKG 5	FOOT	273,557.0	84,548.0	358,105.0											
	X7830074	GRV RCSD PVT MRKG 7	FOOT	6,974.5	2,775.5	9,750.0											
	X7830076	GRV RCSD PVT MRKG 9	FOOT	2,920.0	0.0	2,920.0											
	X7830078	GRV RCSD PVT MRKG 13	FOOT	6,120.8	2,520.2	8,641.0											
	X7830090	GRV RCSD PVT MRKG 25	FOOT	6,970.5	1,533.5	8,504.0											
	78000100	THPL PVT MK LTR & SYM	SQ FT	6,774.3	2,534.5	9,308.8			329	8	22	11	40	95	3	3	0
	78000200	THLP PVT MK LINE 4	FOOT	170,940.0	73,025.0	243,965.0	136,405.0	107,560.0									
	78000400	THLP PVT MK LINE 6	FOOT	4,014.5	2,475.5	6,490.0	6,490.0	0.0									
	78000500	THLP PVT MK LINE 8	FOOT	0.0	0.0	0.0	0.0	0.0									
	78000600	THLP PVT MK LINE 12	FOOT	3,345.8	2,344.2	5,690.0	3,795.0	1,895.0									
	78000650	THLP PVT MK LINE 24	FOOT	5,275.5	1,365.5	6,641.0	6,641.0	0.0									
	78008300	POLYUREA PM T2 LTR-SY	SQ FT	2,385.0	265.8	2,650.8			144	6	2	1	2	0			2
	78008310	POLYUREA PM T2 LN 4	FOOT	102,617.0	11,523.0	114,140.0	64,090.0	50,050.0									
	78008330	POLYUREA PM T2 LN 6	FOOT	2,960.0	300.0	3,260.0	3,260.0	0.0									
	78008340	POLYUREA PM T2 LN 8	FOOT	2,920.0	0.0	2,920.0	2,920.0	0.0									
	78008350	POLYUREA PM T2 LN 12	FOOT	2,775.0	176.0	2,951.0	2,231.0	720.0									
	78008370	POLYUREA PM T2 LN 24	FOOT	1,695.0	168.0	1,863.0	1,863.0	0.0									

MODEL: I:\MODEL\MHFS
 FILE: MHFS_Plan\pdm\com\data\illinois\gov\pww\DOT\Documents\DOT_Offices\Illin\5\Projects\0546534\CADDData\Design\Backups\0546534-int-Schedule.dgn

* DEWITT, MCLEAN, PIATT ** D-5HT PVMNT MRK RPR 20-22

USER NAME = farnhamba	DESIGNED -	REVISED -
	DRAWN -	REVISED -
PLOT SCALE = 40.0000 ' / in.	CHECKED -	REVISED -
PLOT DATE = 10/15/2019	DATE -	REVISED -

**STATE OF ILLINOIS
DEPARTMENT OF TRANSPORTATION**

SCHEDULE OF QUANTITIES

SCALE: SHEET 22 OF 29 SHEETS STA. TO STA.

F.A. RTE.	SECTION	COUNTY	TOTAL SHEETS	SHEET NO.
VAR	**	-	45	33
CONTRACT NO. 46534				
		ILLINOIS	FED. AID PROJECT	

PIATT COUNTY

Location #1: RR 1/2 mile North of US 36 on Bement Road

Urban/ Rural	Pay Item	Description	Unit	Quantity	White	Yellow	Lt/Rt Arrow	Wrong Way Arrow	Railroad "R"	Railroad "X"	Comb. Arrow	Straight Arrow
RURAL	X0327980	PAVT MARKING REMOVAL	SQ FT	0.0								
RURAL	X7830060	GRV RCSD PM LTR & SYM	SQ FT	122.4								
RURAL	X7830070	GRV RCSD PVT MRKG 5	FOOT	0.0								
RURAL	X7830074	GRV RCSD PVT MRKG 7	FOOT	0.0								
RURAL	X7830076	GRV RCSD PVT MRKG 9	FOOT	0.0								
RURAL	X7830078	GRV RCSD PVT MRKG 13	FOOT	0.0								
RURAL	X7830090	GRV RCSD PVT MRKG 25	FOOT	72.0								
RURAL	78000100	THPL PVT MK LTR & SYM	SQ FT	122.4			0	0	4	2	0	0
RURAL	78000200	THLP PVT MK LINE 4	FOOT	0.0	0.0	0.0						
RURAL	78000400	THLP PVT MK LINE 6	FOOT	0.0	0.0	0.0						
RURAL	78000500	THLP PVT MK LINE 8	FOOT	0.0	0.0	0.0						
RURAL	78000600	THLP PVT MK LINE 12	FOOT	0.0	0.0	0.0						
RURAL	78000650	THLP PVT MK LINE 24	FOOT	72.0	72.0	0.0						
RURAL	78008300	POLYUREA PM T2 LTR-SY	SQ FT	0.0			0	0	0	0	0	0
RURAL	78008310	POLYUREA PM T2 LN 4	FOOT	0.0	0.0	0.0						
RURAL	78008330	POLYUREA PM T2 LN 6	FOOT	0.0	0.0	0.0						
RURAL	78008340	POLYUREA PM T2 LN 8	FOOT	0.0	0.0	0.0						
RURAL	78008350	POLYUREA PM T2 LN 12	FOOT	0.0	0.0	0.0						
RURAL	78008370	POLYUREA PM T2 LN 24	FOOT	0.0	0.0	0.0						

Location #2: IL 32 & IL 105 2 miles South of Cerro Gordo

Urban/ Rural	Pay Item	Description	Unit	Quantity	White	Yellow	Lt/Rt Arrow	Wrong Way Arrow	Railroad "R"	Railroad "X"	Comb. Arrow	Straight Arrow
RURAL	X0327980	PAVT MARKING REMOVAL	SQ FT	0.0								
RURAL	X7830060	GRV RCSD PM LTR & SYM	SQ FT	124.8								
RURAL	X7830070	GRV RCSD PVT MRKG 5	FOOT	11,225.0								
RURAL	X7830074	GRV RCSD PVT MRKG 7	FOOT	170.0								
RURAL	X7830076	GRV RCSD PVT MRKG 9	FOOT	0.0								
RURAL	X7830078	GRV RCSD PVT MRKG 13	FOOT	440.0								
RURAL	X7830090	GRV RCSD PVT MRKG 25	FOOT	108.0								
RURAL	78000100	THPL PVT MK LTR & SYM	SQ FT	109.2			7	0	0	0	0	0
RURAL	78000200	THLP PVT MK LINE 4	FOOT	11,050.0	4,150.0	6,900.0						
RURAL	78000400	THLP PVT MK LINE 6	FOOT	170.0	170.0	0.0						
RURAL	78000500	THLP PVT MK LINE 8	FOOT	0.0	0.0	0.0						
RURAL	78000600	THLP PVT MK LINE 12	FOOT	440.0	180.0	260.0						
RURAL	78000650	THLP PVT MK LINE 24	FOOT	108.0	108.0	0.0						
RURAL	78008300	POLYUREA PM T2 LTR-SY	SQ FT	15.6			1	0	0	0	0	0
RURAL	78008310	POLYUREA PM T2 LN 4	FOOT	175.0	105.0	70.0						
RURAL	78008330	POLYUREA PM T2 LN 6	FOOT	0.0	0.0	0.0						
RURAL	78008340	POLYUREA PM T2 LN 8	FOOT	0.0	0.0	0.0						
RURAL	78008350	POLYUREA PM T2 LN 12	FOOT	0.0	0.0	0.0						
RURAL	78008370	POLYUREA PM T2 LN 24	FOOT	0.0	0.0	0.0						

MODEL: s:\MODEL\MHMS
 FILE: mhms_01.dwg
 PROJECT: D:\Projects\0546534\CADDData\Design\Backups\0546534-01-5-Schedule.dgn

* DEWITT, MCLEAN, PIATT ** D-SHT PVMNT MRK RPR 20-22

USER NAME = farnhamba	DESIGNED -	REVISED -	STATE OF ILLINOIS DEPARTMENT OF TRANSPORTATION	SCHEDULE OF QUANTITIES				F.A. RTE.	SECTION	COUNTY	TOTAL SHEETS	SHEET NO.
	DRAWN -	REVISED -									45	34
PLOT SCALE = 40.0000 ' / in.	CHECKED -	REVISED -									CONTRACT NO. 46534	
PLOT DATE = 10/15/2019	DATE -	REVISED -			SCALE:	SHEET 23	OF 29 SHEETS	STA.	TO STA.	ILLINOIS FED. AID PROJECT		

PIATT COUNTY

Location #3: IL 32 & IL 105 @ Cerro Gordo

Urban/ Rural	Pay Item	Description	Unit	Quantity	White	Yellow	Lt/Rt Arrow	Wrong Way Arrow	Railroad "R"	Railroad "X"	Comb. Arrow	Straight Arrow
RURAL	X0327980	PAVT MARKING REMOVAL	SQ FT	0.0								
RURAL	X7830060	GRV RCSD PM LTR & SYM	SQ FT	122.4								
RURAL	X7830070	GRV RCSD PVT MRKG 5	FOOT	2,590.0								
RURAL	X7830074	GRV RCSD PVT MRKG 7	FOOT	0.0								
RURAL	X7830076	GRV RCSD PVT MRKG 9	FOOT	0.0								
RURAL	X7830078	GRV RCSD PVT MRKG 13	FOOT	50.0								
RURAL	X7830090	GRV RCSD PVT MRKG 25	FOOT	140.0								
RURAL	78000100	THPL PVT MK LTR & SYM	SQ FT	122.4			0	0	4	2	0	0
RURAL	78000200	THLP PVT MK LINE 4	FOOT	2,590.0	90.0	2,500.0						
RURAL	78000400	THLP PVT MK LINE 6	FOOT	0.0	0.0	0.0						
RURAL	78000500	THLP PVT MK LINE 8	FOOT	0.0	0.0	0.0						
RURAL	78000600	THLP PVT MK LINE 12	FOOT	50.0	50.0	0.0						
RURAL	78000650	THLP PVT MK LINE 24	FOOT	140.0	140.0	0.0						
RURAL	78008300	POLYUREA PM T2 LTR-SY	SQ FT	0.0			0	0	0	0	0	0
RURAL	78008310	POLYUREA PM T2 LN 4	FOOT	0.0	0.0	0.0						
RURAL	78008330	POLYUREA PM T2 LN 6	FOOT	0.0	0.0	0.0						
RURAL	78008340	POLYUREA PM T2 LN 8	FOOT	0.0	0.0	0.0						
RURAL	78008350	POLYUREA PM T2 LN 12	FOOT	0.0	0.0	0.0						
RURAL	78008370	POLYUREA PM T2 LN 24	FOOT	0.0	0.0	0.0						

Location #4: IL 32 @ RR in Cisco

Urban/ Rural	Pay Item	Description	Unit	Quantity	White	Yellow	Lt/Rt Arrow	Wrong Way Arrow	Railroad "R"	Railroad "X"	Comb. Arrow	Straight Arrow
RURAL	X0327980	PAVT MARKING REMOVAL	SQ FT	0.0								
RURAL	X7830060	GRV RCSD PM LTR & SYM	SQ FT	122.4								
RURAL	X7830070	GRV RCSD PVT MRKG 5	FOOT	0.0								
RURAL	X7830074	GRV RCSD PVT MRKG 7	FOOT	0.0								
RURAL	X7830076	GRV RCSD PVT MRKG 9	FOOT	0.0								
RURAL	X7830078	GRV RCSD PVT MRKG 13	FOOT	0.0								
RURAL	X7830090	GRV RCSD PVT MRKG 25	FOOT	72.0								
RURAL	78000100	THPL PVT MK LTR & SYM	SQ FT	122.4			0	0	4	2	0	0
RURAL	78000200	THLP PVT MK LINE 4	FOOT	0.0	0.0	0.0						
RURAL	78000400	THLP PVT MK LINE 6	FOOT	0.0	0.0	0.0						
RURAL	78000500	THLP PVT MK LINE 8	FOOT	0.0	0.0	0.0						
RURAL	78000600	THLP PVT MK LINE 12	FOOT	0.0	0.0	0.0						
RURAL	78000650	THLP PVT MK LINE 24	FOOT	72.0	72.0	0.0						
RURAL	78008300	POLYUREA PM T2 LTR-SY	SQ FT	0.0			0	0	0	0	0	0
RURAL	78008310	POLYUREA PM T2 LN 4	FOOT	0.0	0.0	0.0						
RURAL	78008330	POLYUREA PM T2 LN 6	FOOT	0.0	0.0	0.0						
RURAL	78008340	POLYUREA PM T2 LN 8	FOOT	0.0	0.0	0.0						
RURAL	78008350	POLYUREA PM T2 LN 12	FOOT	0.0	0.0	0.0						
RURAL	78008370	POLYUREA PM T2 LN 24	FOOT	0.0	0.0	0.0						

MODEL: I:\MODEL\MHMF5
 FILE: MHMF5_Plan\p10m\comada.dwg
 PROJECT: D:\Projects\0546534\CADD\Drawings\Design\Backups\0546534-1015-Schedule.dgn
 OFFICE: I:\DOT\Documents\DOT - Office\1015\1015.dwg

* DEWITT, MCLEAN, PIATT ** D-5HT PVMNT MRK RPR 20-22

USER NAME = farnhamba	DESIGNED -	REVISED -	STATE OF ILLINOIS DEPARTMENT OF TRANSPORTATION	SCHEDULE OF QUANTITIES	F.A. RTE.	SECTION	COUNTY	TOTAL SHEETS	SHEET NO.	
	DRAWN -	REVISED -			VAR	**	-	45	35	
PLOT SCALE = 40.0000' / in.	CHECKED -	REVISED -			CONTRACT NO. 46534					
PLOT DATE = 10/15/2019	DATE -	REVISED -			SCALE:	SHEET 24	OF 29	SHEETS	STA.	TO STA.

PIATT COUNTY

Location #5: IL 32 & Old Route 47 in Cisco												
Urban/ Rural	Pay Item	Description	Unit	Quantity	White	Yellow	Lt/Rt Arrow	Wrong Way Arrow	Railroad "R"	Railroad "X"	Comb. Arrow	Straight Arrow
RURAL	X0327980	PAVT MARKING REMOVAL	SQ FT	0.0								
RURAL	X7830060	GRV RCSD PM LTR & SYM	SQ FT	0.0								
RURAL	X7830070	GRV RCSD PVT MRKG 5	FOOT	0.0								
RURAL	X7830074	GRV RCSD PVT MRKG 7	FOOT	0.0								
RURAL	X7830076	GRV RCSD PVT MRKG 9	FOOT	0.0								
RURAL	X7830078	GRV RCSD PVT MRKG 13	FOOT	0.0								
RURAL	X7830090	GRV RCSD PVT MRKG 25	FOOT	13.0								
RURAL	78000100	THPL PVT MK LTR & SYM	SQ FT	0.0			0	0	0	0	0	0
RURAL	78000200	THLP PVT MK LINE 4	FOOT	0.0	0.0	0.0						
RURAL	78000400	THLP PVT MK LINE 6	FOOT	0.0	0.0	0.0						
RURAL	78000500	THLP PVT MK LINE 8	FOOT	0.0	0.0	0.0						
RURAL	78000600	THLP PVT MK LINE 12	FOOT	0.0	0.0	0.0						
RURAL	78000650	THLP PVT MK LINE 24	FOOT	13.0	13.0	0.0						
RURAL	78008300	POLYUREA PM T2 LTR-SY	SQ FT	0.0			0	0	0	0	0	0
RURAL	78008310	POLYUREA PM T2 LN 4	FOOT	0.0	0.0	0.0						
RURAL	78008330	POLYUREA PM T2 LN 6	FOOT	0.0	0.0	0.0						
RURAL	78008340	POLYUREA PM T2 LN 8	FOOT	0.0	0.0	0.0						
RURAL	78008350	POLYUREA PM T2 LN 12	FOOT	0.0	0.0	0.0						
RURAL	78008370	POLYUREA PM T2 LN 24	FOOT	0.0	0.0	0.0						

Location #6: Il 105 & Bement Road 1 1/2 miles South of Bement												
Urban/ Rural	Pay Item	Description	Unit	Quantity	White	Yellow	Lt/Rt Arrow	Wrong Way Arrow	Railroad "R"	Railroad "X"	Comb. Arrow	Straight Arrow
RURAL	X0327980	PAVT MARKING REMOVAL	SQ FT	0.0								
RURAL	X7830060	GRV RCSD PM LTR & SYM	SQ FT	0.0								
RURAL	X7830070	GRV RCSD PVT MRKG 5	FOOT	4,460.0								
RURAL	X7830074	GRV RCSD PVT MRKG 7	FOOT	210.0								
RURAL	X7830076	GRV RCSD PVT MRKG 9	FOOT	0.0								
RURAL	X7830078	GRV RCSD PVT MRKG 13	FOOT	310.0								
RURAL	X7830090	GRV RCSD PVT MRKG 25	FOOT	0.0								
RURAL	78000100	THPL PVT MK LTR & SYM	SQ FT	0.0			0	0	0	0	0	0
RURAL	78000200	THLP PVT MK LINE 4	FOOT	4,460.0	680.0	3,780.0						
RURAL	78000400	THLP PVT MK LINE 6	FOOT	210.0	210.0	0.0						
RURAL	78000500	THLP PVT MK LINE 8	FOOT	0.0	0.0	0.0						
RURAL	78000600	THLP PVT MK LINE 12	FOOT	310.0	0.0	310.0						
RURAL	78000650	THLP PVT MK LINE 24	FOOT	0.0	0.0	0.0						
RURAL	78008300	POLYUREA PM T2 LTR-SY	SQ FT	0.0			0	0	0	0	0	0
RURAL	78008310	POLYUREA PM T2 LN 4	FOOT	0.0	0.0	0.0						
RURAL	78008330	POLYUREA PM T2 LN 6	FOOT	0.0	0.0	0.0						
RURAL	78008340	POLYUREA PM T2 LN 8	FOOT	0.0	0.0	0.0						
RURAL	78008350	POLYUREA PM T2 LN 12	FOOT	0.0	0.0	0.0						
RURAL	78008370	POLYUREA PM T2 LN 24	FOOT	0.0	0.0	0.0						

MODEL: s:\MODEL\MH\MS
 FILE: hamba_piatt\hamboma.dwg
 PROJECT: D:\Projects\0546534\CADDData\Design\Backups\0546534-ent-Schedule.dgn
 OFFICE: IDOT
 DATE: 10/15/2019

* DEWITT, MCLEAN, PIATT ** D-SHT PVMNT MRK RPR 20-22

USER NAME = farnhamba DESIGNED - DRAWN - PLOT SCALE = 40.0000 ' / in. CHECKED - PLOT DATE = 10/15/2019 DATE -	REVISED - REVISED - REVISED - REVISED -	STATE OF ILLINOIS DEPARTMENT OF TRANSPORTATION	SCHEDULE OF QUANTITIES	SCALE: SHEET 25 OF 29 SHEETS STA. TO STA.
				F.A. RTE. SECTION COUNTY TOTAL SHEETS SHEET NO. VAR ** - 45 36 CONTRACT NO. 46534 ILLINOIS FED. AID PROJECT

PIATT COUNTY

Location #7: IL 105 @ RR in Bement

Urban/ Rural	Pay Item	Description	Unit	Quantity	White	Yellow	Lt/Rt Arrow	Wrong Way Arrow	Railroad "R"	Railroad "X"	Comb. Arrow	Straight Arrow
RURAL	X0327980	PAVT MARKING REMOVAL	SQ FT	0.0								
RURAL	X7830060	GRV RCSD PM LTR & SYM	SQ FT	122.4								
RURAL	X7830070	GRV RCSD PVT MRKG 5	FOOT	0.0								
RURAL	X7830074	GRV RCSD PVT MRKG 7	FOOT	0.0								
RURAL	X7830076	GRV RCSD PVT MRKG 9	FOOT	0.0								
RURAL	X7830078	GRV RCSD PVT MRKG 13	FOOT	0.0								
RURAL	X7830090	GRV RCSD PVT MRKG 25	FOOT	120.0								
RURAL	78000100	THPL PVT MK LTR & SYM	SQ FT	122.4			0	0	4	2	0	0
RURAL	78000200	THLP PVT MK LINE 4	FOOT	0.0	0.0	0.0						
RURAL	78000400	THLP PVT MK LINE 6	FOOT	0.0	0.0	0.0						
RURAL	78000500	THLP PVT MK LINE 8	FOOT	0.0	0.0	0.0						
RURAL	78000600	THLP PVT MK LINE 12	FOOT	0.0	0.0	0.0						
RURAL	78000650	THLP PVT MK LINE 24	FOOT	120.0	120.0	0.0						
RURAL	78008300	POLYUREA PM T2 LTR-SY	SQ FT	0.0			0	0	0	0	0	0
RURAL	78008310	POLYUREA PM T2 LN 4	FOOT	0.0	0.0	0.0						
RURAL	78008330	POLYUREA PM T2 LN 6	FOOT	0.0	0.0	0.0						
RURAL	78008340	POLYUREA PM T2 LN 8	FOOT	0.0	0.0	0.0						
RURAL	78008350	POLYUREA PM T2 LN 12	FOOT	0.0	0.0	0.0						
RURAL	78008370	POLYUREA PM T2 LN 24	FOOT	0.0	0.0	0.0						

Location #8: IL 105 @ Kratz Rd (School) in Monticello

Urban/ Rural	Pay Item	Description	Unit	Quantity	White	Yellow	Lt/Rt Arrow	Wrong Way Arrow	Railroad "R"	Railroad "X"	Comb. Arrow	Straight Arrow
URBAN	X0327980	PAVT MARKING REMOVAL	SQ FT	0.0								
URBAN	X7830060	GRV RCSD PM LTR & SYM	SQ FT	15.6								
URBAN	X7830070	GRV RCSD PVT MRKG 5	FOOT	1,535.0								
URBAN	X7830074	GRV RCSD PVT MRKG 7	FOOT	0.0								
URBAN	X7830076	GRV RCSD PVT MRKG 9	FOOT	0.0								
URBAN	X7830078	GRV RCSD PVT MRKG 13	FOOT	80.0								
URBAN	X7830090	GRV RCSD PVT MRKG 25	FOOT	0.0								
URBAN	78000100	THPL PVT MK LTR & SYM	SQ FT	15.6			1	0	0	0	0	0
URBAN	78000200	THLP PVT MK LINE 4	FOOT	1,535.0	35.0	1,500.0						
URBAN	78000400	THLP PVT MK LINE 6	FOOT	0.0	0.0	0.0						
URBAN	78000500	THLP PVT MK LINE 8	FOOT	0.0	0.0	0.0						
URBAN	78000600	THLP PVT MK LINE 12	FOOT	80.0	0.0	80.0						
URBAN	78000650	THLP PVT MK LINE 24	FOOT	0.0	0.0	0.0						
URBAN	78008300	POLYUREA PM T2 LTR-SY	SQ FT	0.0			0	0	0	0	0	0
URBAN	78008310	POLYUREA PM T2 LN 4	FOOT	0.0	0.0	0.0						
URBAN	78008330	POLYUREA PM T2 LN 6	FOOT	0.0	0.0	0.0						
URBAN	78008340	POLYUREA PM T2 LN 8	FOOT	0.0	0.0	0.0						
URBAN	78008350	POLYUREA PM T2 LN 12	FOOT	0.0	0.0	0.0						
URBAN	78008370	POLYUREA PM T2 LN 24	FOOT	0.0	0.0	0.0						

MODEL: I:\MODEL\MHFS
 FILE: MHFS_Plan\Urban\Monticello.dwg
 PROJECT: D:\Projects\0546534\CADD\Drawings\Design\Backups\0546534-ent-Schedule.dgn

USER NAME = farnhamba	DESIGNED -	REVISED -
	DRAWN -	REVISED -
PLOT SCALE = 40.0000 ' / in.	CHECKED -	REVISED -
PLOT DATE = 10/15/2019	DATE -	REVISED -

**STATE OF ILLINOIS
DEPARTMENT OF TRANSPORTATION**

SCHEDULE OF QUANTITIES

SCALE: SHEET 26 OF 29 SHEETS STA. TO STA.

* DEWITT, MCLEAN, PIATT ** D-SHT PVMNT MRK RPR 20-22

F.A. RTE.	SECTION	COUNTY	TOTAL SHEETS	SHEET NO.
VAR	**	-	45	37
			CONTRACT NO. 46534	
		ILLINOIS FED. AID PROJECT		

PIATT COUNTY

Location #9: Old Route 47 & Bridge St in Monticello												
Urban/ Rural	Pay Item	Description	Unit	Quantity	White	Yellow	Lt/Rt Arrow	Wrong Way Arrow	Railroad "R"	Railroad "X"	Comb. Arrow	Straight Arrow
URBAN	X0327980	PAVT MARKING REMOVAL	SQ FT	0.0								
URBAN	X7830060	GRV RCSD PM LTR & SYM	SQ FT	0.0								
URBAN	X7830070	GRV RCSD PVT MRKG 5	FOOT	0.0								
URBAN	X7830074	GRV RCSD PVT MRKG 7	FOOT	165.0								
URBAN	X7830076	GRV RCSD PVT MRKG 9	FOOT	0.0								
URBAN	X7830078	GRV RCSD PVT MRKG 13	FOOT	70.0								
URBAN	X7830090	GRV RCSD PVT MRKG 25	FOOT	32.0								
URBAN	78000100	THPL PVT MK LTR & SYM	SQ FT	0.0			0	0	0	0	0	0
URBAN	78000200	THLP PVT MK LINE 4	FOOT	0.0	0.0	0.0						
URBAN	78000400	THLP PVT MK LINE 6	FOOT	165.0	165.0	0.0						
URBAN	78000500	THLP PVT MK LINE 8	FOOT	0.0	0.0	0.0						
URBAN	78000600	THLP PVT MK LINE 12	FOOT	70.0	70.0	0.0						
URBAN	78000650	THLP PVT MK LINE 24	FOOT	32.0	32.0	0.0						
URBAN	78008300	POLYUREA PM T2 LTR-SY	SQ FT	0.0			0	0	0	0	0	0
URBAN	78008310	POLYUREA PM T2 LN 4	FOOT	0.0	0.0	0.0						
URBAN	78008330	POLYUREA PM T2 LN 6	FOOT	0.0	0.0	0.0						
URBAN	78008340	POLYUREA PM T2 LN 8	FOOT	0.0	0.0	0.0						
URBAN	78008350	POLYUREA PM T2 LN 12	FOOT	0.0	0.0	0.0						
URBAN	78008370	POLYUREA PM T2 LN 24	FOOT	0.0	0.0	0.0						

Location #10: IL 10 & RR in Lodge												
Urban/ Rural	Pay Item	Description	Unit	Quantity	White	Yellow	Lt/Rt Arrow	Wrong Way Arrow	Railroad "R"	Railroad "X"	Comb. Arrow	Straight Arrow
RURAL	X0327980	PAVT MARKING REMOVAL	SQ FT	0.0								
RURAL	X7830060	GRV RCSD PM LTR & SYM	SQ FT	122.4								
RURAL	X7830070	GRV RCSD PVT MRKG 5	FOOT	0.0								
RURAL	X7830074	GRV RCSD PVT MRKG 7	FOOT	0.0								
RURAL	X7830076	GRV RCSD PVT MRKG 9	FOOT	0.0								
RURAL	X7830078	GRV RCSD PVT MRKG 13	FOOT	0.0								
RURAL	X7830090	GRV RCSD PVT MRKG 25	FOOT	72.0								
RURAL	78000100	THPL PVT MK LTR & SYM	SQ FT	0.0			0	0	0	0	0	0
RURAL	78000200	THLP PVT MK LINE 4	FOOT	0.0	0.0	0.0						
RURAL	78000400	THLP PVT MK LINE 6	FOOT	0.0	0.0	0.0						
RURAL	78000500	THLP PVT MK LINE 8	FOOT	0.0	0.0	0.0						
RURAL	78000600	THLP PVT MK LINE 12	FOOT	0.0	0.0	0.0						
RURAL	78000650	THLP PVT MK LINE 24	FOOT	0.0	0.0	0.0						
RURAL	78008300	POLYUREA PM T2 LTR-SY	SQ FT	122.4			0	0	4	2	0	0
RURAL	78008310	POLYUREA PM T2 LN 4	FOOT	0.0	0.0	0.0						
RURAL	78008330	POLYUREA PM T2 LN 6	FOOT	0.0	0.0	0.0						
RURAL	78008340	POLYUREA PM T2 LN 8	FOOT	0.0	0.0	0.0						
RURAL	78008350	POLYUREA PM T2 LN 12	FOOT	0.0	0.0	0.0						
RURAL	78008370	POLYUREA PM T2 LN 24	FOOT	72.0	72.0	0.0						

MODEL: I:\MODEL\MH\MS
 FILE: Mh\MS_Piatt\pdm\mcomada.dwg
 PROJECT: D:\Projects\0546534\CADD\Drawings\Design\Backups\0546534-ent-5-schedule.dgn

USER NAME = farnhamba	DESIGNED -	REVISED -
	DRAWN -	REVISED -
PLOT SCALE = 40.0000 ' / in.	CHECKED -	REVISED -
PLOT DATE = 10/15/2019	DATE -	REVISED -

**STATE OF ILLINOIS
DEPARTMENT OF TRANSPORTATION**

SCHEDULE OF QUANTITIES

SCALE: SHEET 27 OF 29 SHEETS STA. TO STA.

* DEWITT, MCLEAN, PIATT ** D-SHT PVMNT MRK RPR 20-22

F.A. RTE.	SECTION	COUNTY	TOTAL SHEETS	SHEET NO.
VAR	**	-	45	38
			CONTRACT NO. 46534	
		ILLINOIS FED. AID PROJECT		

PIATT COUNTY

Platt County Totals:													
Pay Item	Description	Unit	Urban	Rural	Quantity	White	Yellow	Lt/Rt Arrow	Wrong Way Arrow	Railroad "R"	Railroad "X"	Comb. Arrow	Straight Arrow
X0327980	PAVT MARKING REMOVAL	SQ FT	0.0	0.0	0.0								
X7830060	GRV RCSD PM LTR & SYM	SQ FT	15.6	736.8	752.4								
X7830070	GRV RCSD PVT MRKG 5	FOOT	1,535.0	18,275.0	19,810.0								
X7830074	GRV RCSD PVT MRKG 7	FOOT	165.0	380.0	545.0								
X7830076	GRV RCSD PVT MRKG 9	FOOT	0.0	0.0	0.0								
X7830078	GRV RCSD PVT MRKG 13	FOOT	150.0	800.0	950.0								
X7830090	GRV RCSD PVT MRKG 25	FOOT	32.0	597.0	629.0								
78000100	THPL PVT MK LTR & SYM	SQ FT	15.6	598.8	614.4			8	0	16	8	0	0
78000200	THLP PVT MK LINE 4	FOOT	1,535.0	18,100.0	19,635.0	4,955.0	14,680.0						
78000400	THLP PVT MK LINE 6	FOOT	165.0	380.0	545.0	545.0	0.0						
78000500	THLP PVT MK LINE 8	FOOT	0.0	0.0	0.0	0.0	0.0						
78000600	THLP PVT MK LINE 12	FOOT	150.0	800.0	950.0	300.0	650.0						
78000650	THLP PVT MK LINE 24	FOOT	32.0	525.0	557.0	557.0	0.0						
78008300	POLYUREA PM T2 LTR-SY	SQ FT	0.0	138.0	138.0			1	0	4	2	0	0
78008310	POLYUREA PM T2 LN 4	FOOT	0.0	175.0	175.0	105.0	70.0						
78008330	POLYUREA PM T2 LN 6	FOOT	0.0	0.0	0.0	0.0	0.0						
78008340	POLYUREA PM T2 LN 8	FOOT	0.0	0.0	0.0	0.0	0.0						
78008350	POLYUREA PM T2 LN 12	FOOT	0.0	0.0	0.0	0.0	0.0						
78008370	POLYUREA PM T2 LN 24	FOOT	0.0	72.0	72.0	72.0	0.0						

MODEL: \\MODEL\MHFS
 FILE: \\mhfs_piatt\piatt\com\data\illinois.gov\PIATT\DOT\Documents\DOT_Offices\Dir\dtc_5\Projects\0546534\CADDData\Design\Backups\0546534-ent-5-schedule.dgn

* DEWITT, MCLEAN, PIATT ** D-SHT PVMNT MRK RPR 20-22

USER NAME = farnhamba	DESIGNED -	REVISED -	STATE OF ILLINOIS DEPARTMENT OF TRANSPORTATION	SCHEDULE OF QUANTITIES				F.A. RTE.	SECTION	COUNTY	TOTAL SHEETS	SHEET NO.
PLOT SCALE = 40.0000 ' / in.	DRAWN -	REVISED -						VAR	**	-	45	39
PLOT DATE = 10/15/2019	CHECKED -	REVISED -		SCALE: SHEET 28 OF 29 SHEETS STA. TO STA.				CONTRACT NO. 46534				
	DATE -	REVISED -		ILLINOIS FED. AID PROJECT								

GRAND COUNTY TOTALS

Grand County Totals:																
Pay Item	Description	Unit	Urban	Rural	Quantity	White	Yellow	Lt/Rt Arrow	Wrong Way Arrow	Railroad "R"	Railroad "X"	Comb. Arrow	Straight Arrow	"BIKE"	"XING"	Lane Drop Arrow
X0327980	PAVT MARKING REMOVAL	SQ FT	780.0	282.0	1062.0											
X7830060	GRV RCSD PM LTR & SYM	SQ FT	11,700.6	3,865.6	15,566.2											
X7830070	GRV RCSD PVT MRKG 5	FOOT	328,772.0	265,173.0	593,945.0											
X7830074	GRV RCSD PVT MRKG 7	FOOT	8,004.5	3,945.5	11,950.0											
X7830076	GRV RCSD PVT MRKG 9	FOOT	3,080.0	7,000.0	10,080.0											
X7830078	GRV RCSD PVT MRKG 13	FOOT	7,064.8	3,847.2	10,912.0											
X7830090	GRV RCSD PVT MRKG 25	FOOT	7,848.5	2,548.5	10,397.0											
78000100	THPL PVT MK LTR & SYM	SQ FT	9,254.7	3,491.5	12,746.2			507	10	42	21	40	95	3	3	
78000200	THLP PVT MK LINE 4	FOOT	214,225.0	117,275.0	331,500.0	157,720.0	173,780.0									
78000400	THLP PVT MK LINE 6	FOOT	4,329.5	3,645.5	7,975.0	7,975.0	0.0									
78000500	THLP PVT MK LINE 8	FOOT	120.0	0.0	120.0	0.0	120.0									
78000600	THLP PVT MK LINE 12	FOOT	4,035.8	3,671.2	7,707.0	4,510.0	3,197.0									
78000650	THLP PVT MK LINE 24	FOOT	5,838.5	2,308.5	8,147.0	8,147.0	0.0									
78008300	POLYUREA PM T2 LTR-SY	SQ FT	2,416.2	403.8	2,820.0			147	6	6	3	2	0			2
78008310	POLYUREA PM T2 LN 4	FOOT	114,547.0	147,898.0	262,445.0	149,945.0	112,500.0									
78008330	POLYUREA PM T2 LN 6	FOOT	3,675.0	300.0	3,975.0	3,975.0	0.0									
78008340	POLYUREA PM T2 LN 8	FOOT	2,960.0	7,000.0	9,960.0	9,960.0	0.0									
78008350	POLYUREA PM T2 LN 12	FOOT	3,029.0	176.0	3,205.0	2,485.0	720.0									
78008370	POLYUREA PM T2 LN 24	FOOT	2,010.0	240.0	2,250.0	2,250.0	0.0									

MODEL: I:\MODEL\NAMES
 FILE: N:\nams: p:\pub\mcom\data\illinois.gov\PI\DOT\Documents\DOT_Offices\Dir\ctc 5\Projects\0546534\CADDData\Design\Backups\0546534-int-5\schedule.dgn

* DEWITT, MCLEAN, PIATT ** D-SHT PVMNT MRK RPR 20-22

USER NAME = farnhamba	DESIGNED -	REVISED -	STATE OF ILLINOIS DEPARTMENT OF TRANSPORTATION	SCHEDULE OF QUANTITIES				F.A. RTE.	SECTION	COUNTY	TOTAL SHEETS	SHEET NO.
DRAWN -	REVISED -	VAR						**	-	45	40	
PLOT SCALE = 40.0000 ' / in.	CHECKED -	REVISED -		CONTRACT NO. 46534				ILLINOIS FED. AID PROJECT				
PLOT DATE = 10/15/2019	DATE -	REVISED -		SCALE:	SHEET 29	OF 29	SHEETS	STA.	TO STA.			

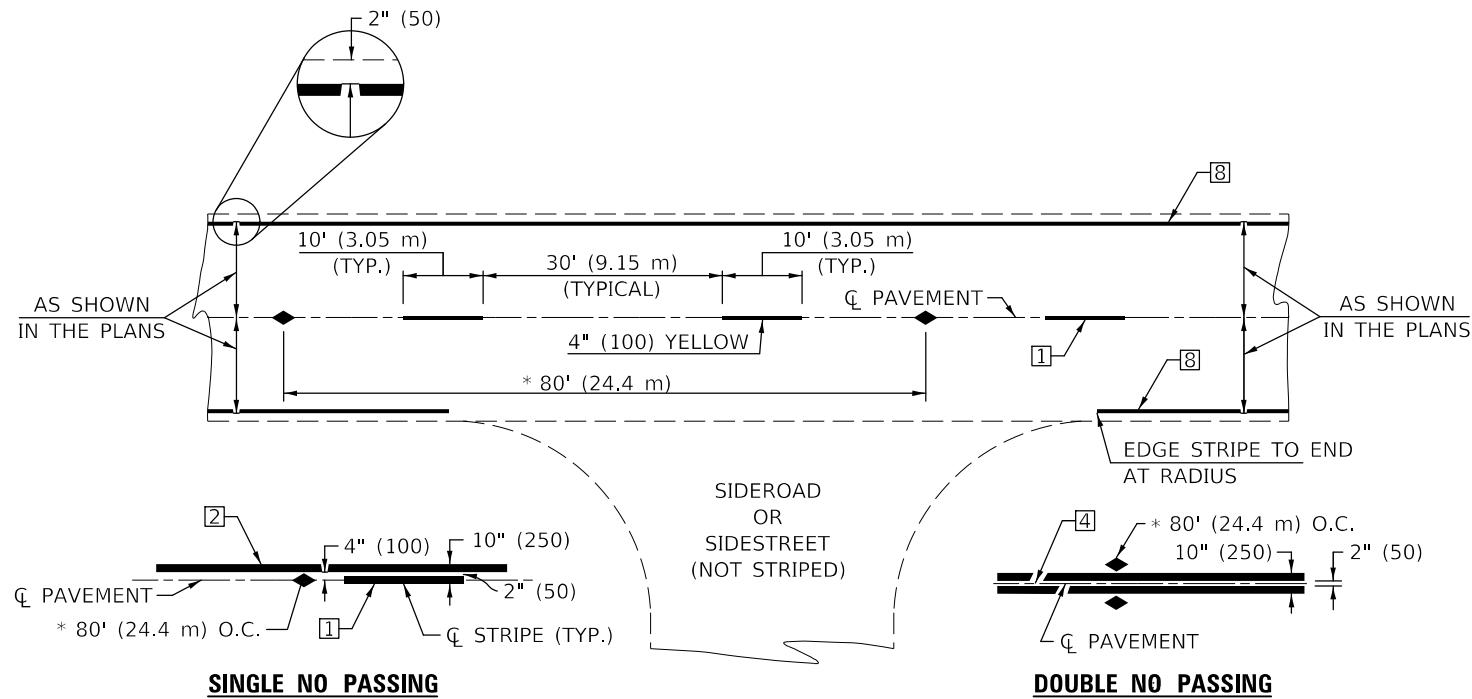

* REDUCE TO 40' (12.2 m) O.C. ON CURVES WITH POSTED OR ADVISORY SPEEDS OF 45 mph (70 km/h) OR LESS.

TWO LANE/TWO WAY

TYPICAL PAVEMENT MARKING LEGEND

- 1 4" (100) SKIP-DASH (YELLOW)
- 2 4" (100) SOLID (YELLOW)
- 3 12" (300) DIAGONAL (YELLOW)
- 4 4" (100) DOUBLE YELLOW (NARROW)
- 5 RESERVED
- 6 RESERVED
- 7 4" (100) SKIP-DASH (WHITE)
- 8 4" (100) SOLID (WHITE)
- 9 12" (300) DIAGONAL (WHITE)
- 10 6" (150) SOLID (WHITE)
- 11 24" (600) STOP BAR (WHITE)
- 12 8" (200) SOLID (WHITE)
- 13 4" (100) LANE LINE EXTENSIONS (WHITE)
- 14 4" (100) PARKING WHITE

TYPICAL PAVEMENT MARKERS LEGEND

- ◆ TWO-WAY AMBER MARKER
- ▶ ONE-WAY AMBER MARKER
- ▷ ONE-WAY CRYSTAL MARKER

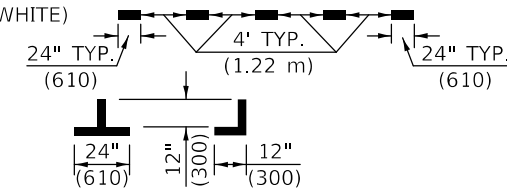
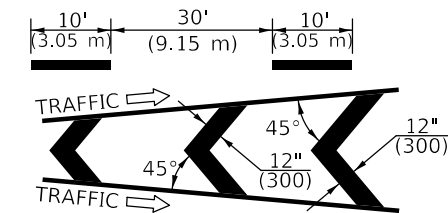
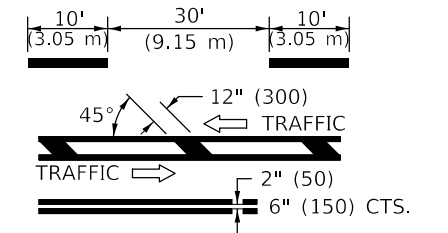

RURAL LEFT TURN

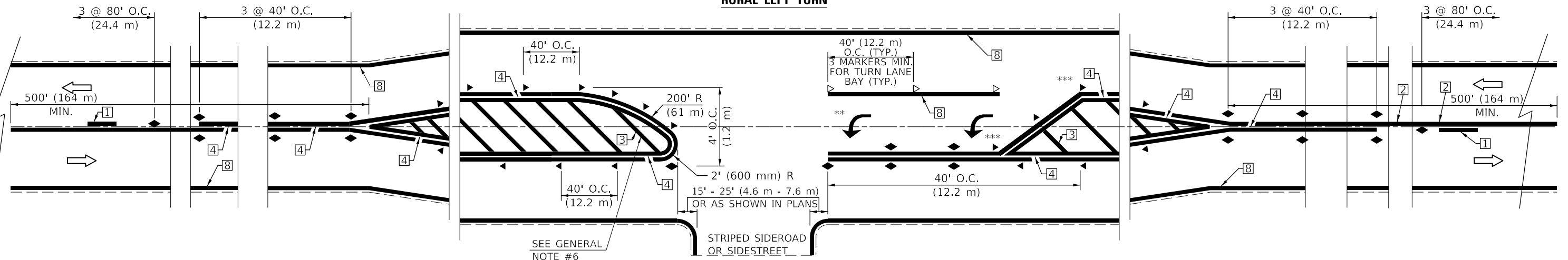

*** REDUCE SPACING IF NECESSARY TO ASSURE MARKERS AT CORNER POINTS.
 ** TURN ARROWS SHALL BE PLACED AS SHOWN ON SHEET #2.

Note: All dimensions are in INCHES (millimeters) unless otherwise shown.

DISTRICT 5 DETAIL NO. 7800AAAA

USER NAME = farnhamba	DESIGNED -	REVISED - 11/06
	DRAWN -	REVISED - 9/2009 KJT
PLOT SCALE = 40,0000 ' / in.	CHECKED -	REVISED - 04/14 JLA
PLOT DATE = 10/15/2019	DATE -	REVISED - 3/2019 SWN

**STATE OF ILLINOIS
DEPARTMENT OF TRANSPORTATION**

**PAVEMENT MARKING AND MARKERS
(RURAL & URBAN APPLICATIONS)**

SCALE: SHEET 1 OF 4 SHEETS STA. TO STA.

F.A. RTE.	SECTION	COUNTY	TOTAL SHEETS	SHEET NO.
	**		45	41
CONTRACT NO. 46534				

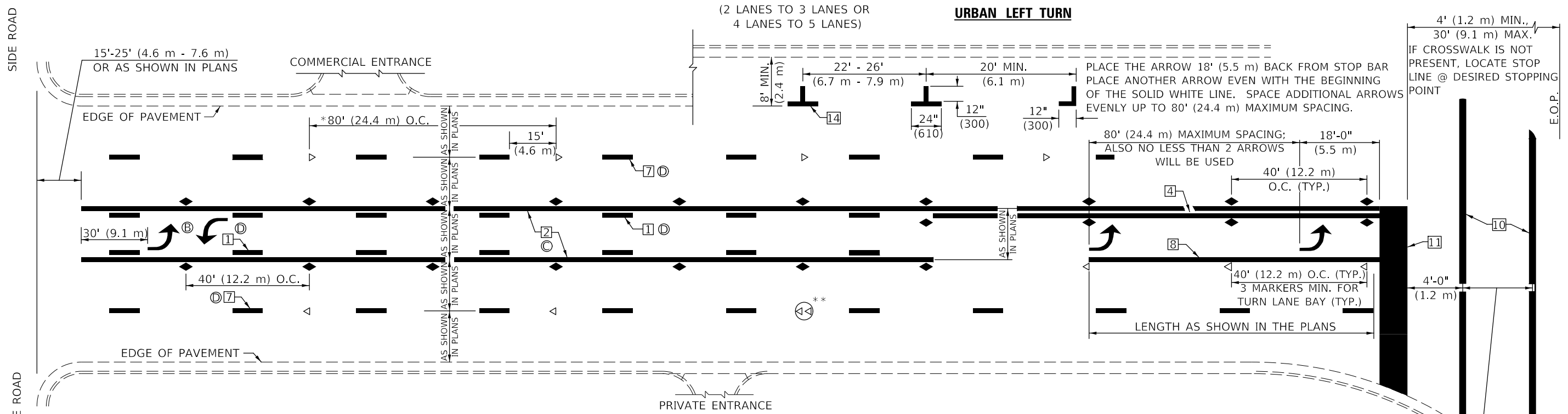

* REDUCE TO 40 FEET (12.2 METERS) ON CENTER ON CURVES WHERE ADVISORY SPEEDS ARE 10 MPH (15 km/h) LOWER THAN POSTED SPEEDS.

** DOUBLE LANE LINE MARKERS SHALL BE SPECIFIED AND SPACED AS SHOWN IN HIGHWAY STANDARD 781001 FOR MULTI-LANE DIVIDED AND UNDIVIDED HIGHWAYS.

GENERAL NOTES:

- ⓑ TURN ARROW PAIRS SHALL BE PLACED AT 250' (75 m) INTERVALS AND SHALL BE EVENLY SPACED BETWEEN BOTH ENDS OF THE BIDIRECTIONAL LEFT TURN LANE.
- ⓒ THE SOLID YELLOW PAVEMENT MARKINGS ② SHOULD GENERALLY START OR END NEAR THE RADIUS POINT OF EACH STREET RETURN EXCEPT WHERE ONE OR BOTH ENDS WOULD INCLUDE STOP BARS.
- ⓓ THE SKIP-DASH PAVEMENT MARKINGS ① OR ⑦ SHOULD BE CENTERED BETWEEN BOTH ENDS OF EACH CITY BLOCK AND SHALL BE PLACED SO THEY LINE UP ACROSS FROM EACH OTHER. SEE EXAMPLE ON SHEET 2 OF 3.
- ⓔ USE LARGE ARROW SIZE FOR BOTH RURAL AND URBAN LOCATIONS. (SEE LAST PAGE OF SECTION 780x FOR SYMBOLS TABLE)

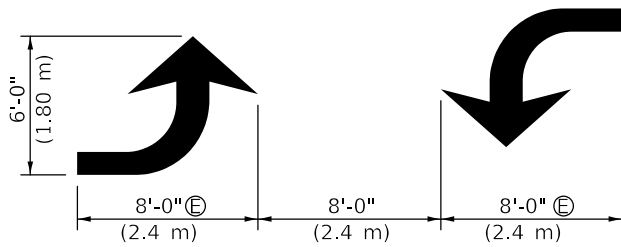
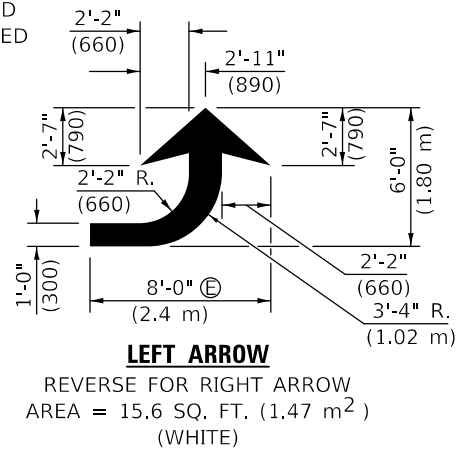

BLOOMINGTON-NORMAL CITY LIMITS ONLY

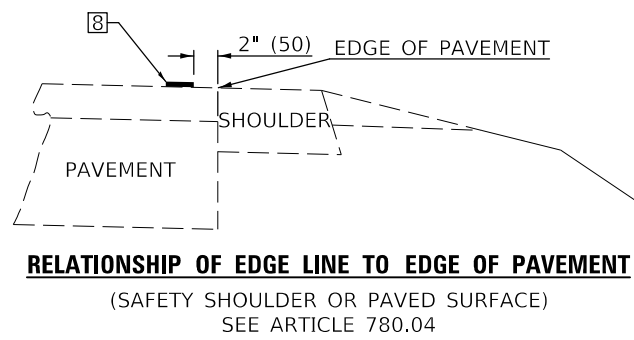
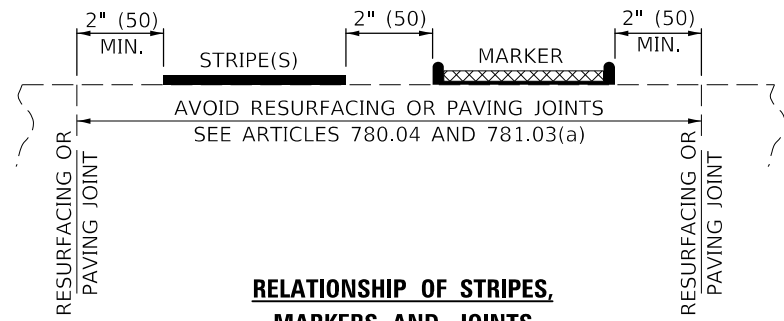
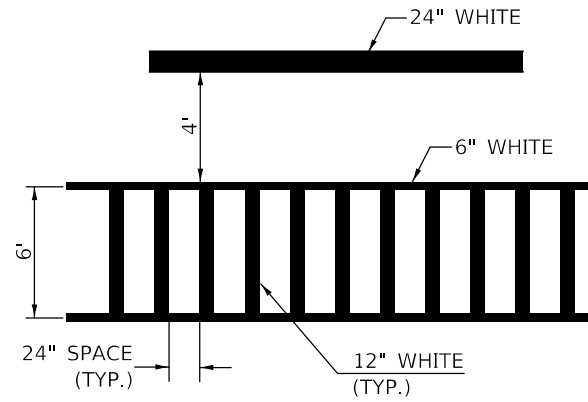

Note: All dimensions are in INCHES (millimeters) unless otherwise shown.

DISTRICT 5 DETAIL NO. 7800AAAA

USER NAME = farnhamba	DESIGNED -	REVISOR -	11/06
	DRAWN -	REVISOR -	9/2009 KJT
PLOT SCALE = 40.0000 ' / in.	CHECKED -	REVISOR -	04/14 JLA
PLOT DATE = 10/15/2019	DATE -	REVISOR -	3/2019 SWN

**STATE OF ILLINOIS
DEPARTMENT OF TRANSPORTATION**

**PAVEMENT MARKING AND MARKERS
(RURAL & URBAN APPLICATIONS)**

F.A. RTE.	SECTION	COUNTY	TOTAL SHEETS	SHEET NO.
	**		45	42
CONTRACT NO. 46534				

SCALE: SHEET 2 OF 4 SHEETS STA. TO STA.

MODEL: 44002L\MARKS FILE: MARKS_PAV\BloomingtonNormal\DOT_Documents\DOT_Office\Detail\5-Projects\IDS46534\CADDData\CAD\Sheet\IDS46534-42-Detail.dgn

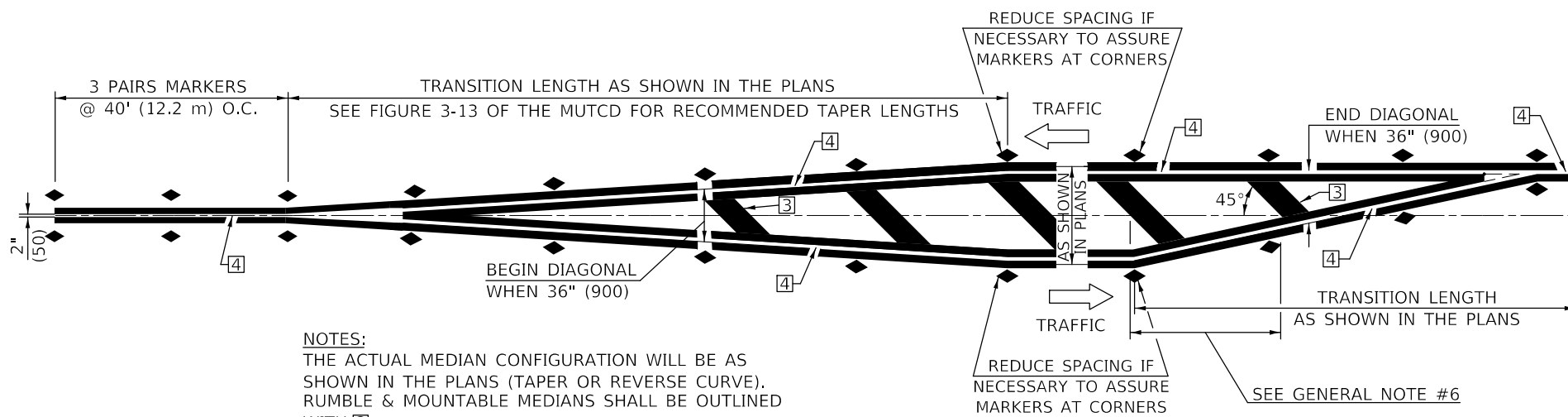

NOTES:
 THE ACTUAL MEDIAN CONFIGURATION WILL BE AS SHOWN IN THE PLANS (TAPER OR REVERSE CURVE). RUMBLE & MOUNTABLE MEDIANS SHALL BE OUTLINED WITH [2].

TYPICAL MEDIAN TRANSITIONS

GENERAL NOTES

1. WHEN MEDIANS ARE PRESENT, PAVEMENT MARKINGS ARE TO BE PLACED ADJACENT TO MEDIANS.
2. SOME OF THE INFORMATION INCLUDED WITH THIS DETAIL MAY NOT BE APPLICABLE TO THIS IMPROVEMENT.
3. PAVEMENT MARKINGS ARE TO BE EXTENDED THROUGH OMISSIONS WHEN APPLICABLE.
4. A STRIPING KEY IS AVAILABLE ELSEWHERE AND SHALL BE SHOWN WHERE THE QUANTITIES ARE LISTED.
5. FINAL PAVEMENT MARKINGS SHALL BE IN PLACE PRIOR TO PLACING ANY RAISED REFLECTIVE PAVEMENT MARKERS.
6. THE FOLLOWING CRITERIA SHALL BE USED FOR SELECTING THE DIAGONAL PAVEMENT MARKING SPACING,
 <30 MPH USE 15' (<50 km/h USE 4.5 m)
 30-45 MPH USE 20' (50-75 km/h USE 6.0 m)
 >45 MPH USE 30' (>75 km/h USE 9.0 m)

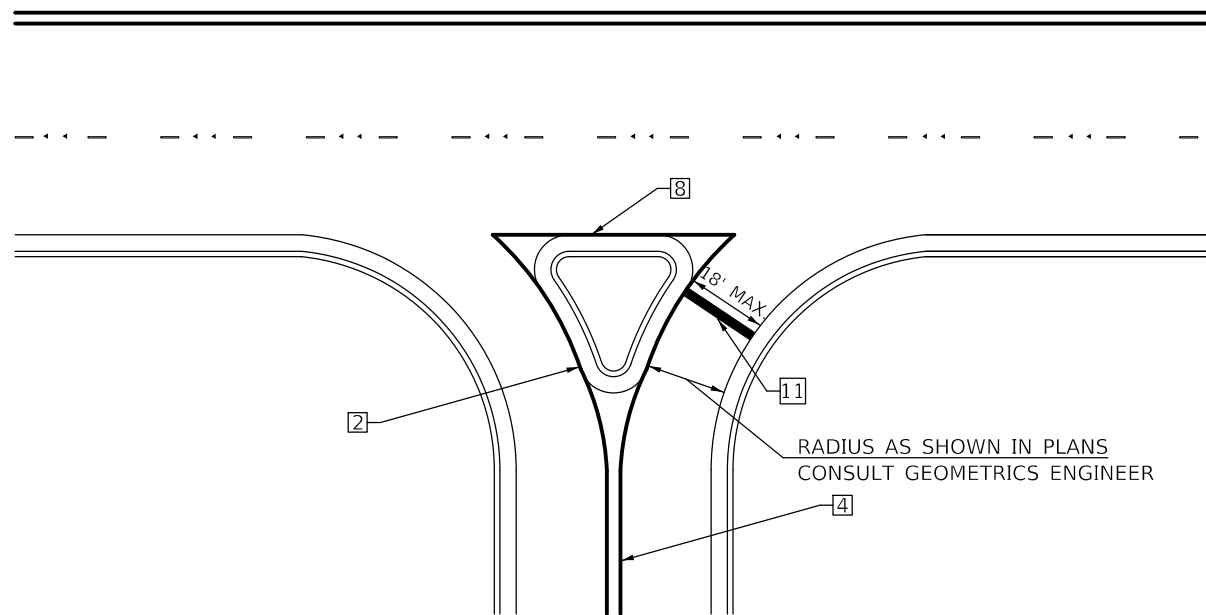

RIGHT IN - RIGHT OUT ACCESS

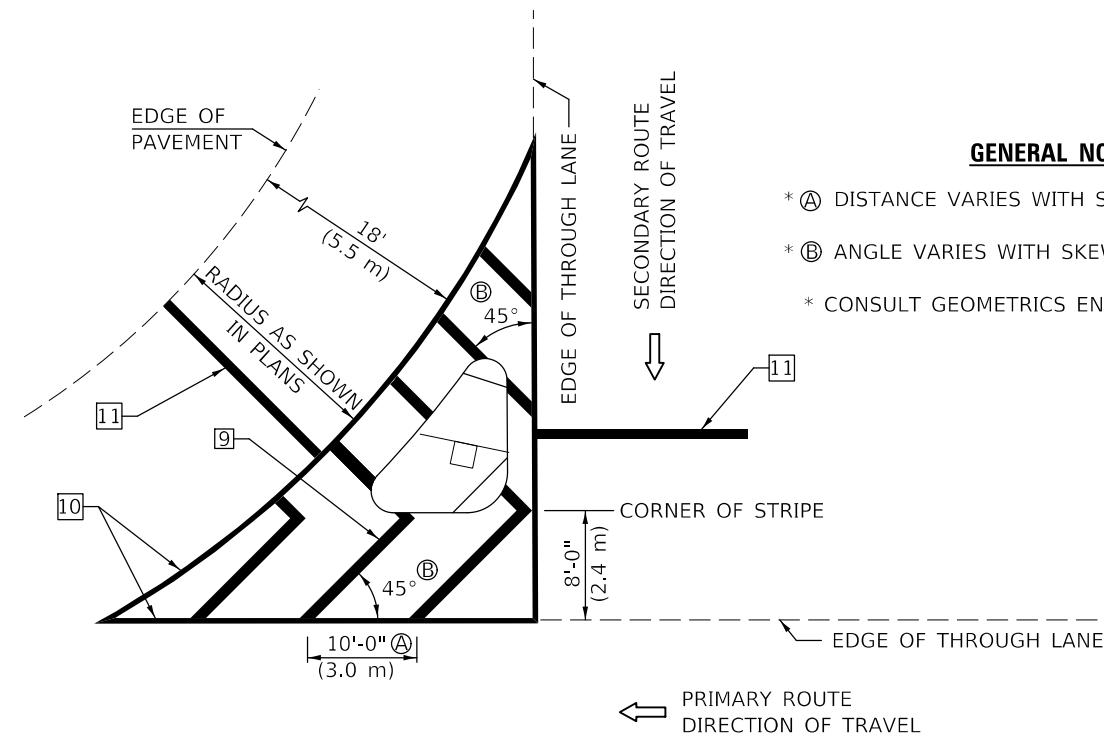

ISLAND

GENERAL NOTES

- * A DISTANCE VARIES WITH SKEW OF INTERSECTION.
- * B ANGLE VARIES WITH SKEW OF INTERSECTION.
- * CONSULT GEOMETRICS ENGINEER

Note: All dimensions are in INCHES (millimeters) unless otherwise shown.

DISTRICT 5 DETAIL NO. 7800AAAA

USER NAME = farnhamba	DESIGNED -	REVISED - 11/06
	DRAWN -	REVISED - 9/2009 KJT
PLOT SCALE = 40,0000 ' / in.	CHECKED -	REVISED - 04/14 JLA
PLOT DATE = 10/15/2019	DATE -	REVISED - 3/2019 SWN

**STATE OF ILLINOIS
 DEPARTMENT OF TRANSPORTATION**

**PAVEMENT MARKING AND MARKERS
 (RURAL & URBAN APPLICATIONS)**

SCALE: SHEET 3 OF 4 SHEETS STA. TO STA.

F.A. RTE.	SECTION	COUNTY	TOTAL SHEETS	SHEET NO.
VAR	**	*	45	43
			CONTRACT NO. 46534	

MODEL: \\MODEL\MARF5
 FILE: MARF5_PAV\pvmnt\mrk_rpr\illinois\dot\office\detail.ctb S:\projects\0546534\CADD\data\CAD\pieces\0546534\pvmnt\detail.dgn

CENTERLINE INTERSTATE OR MULTI-LANE TWO WAY DIVIDED HIGHWAY

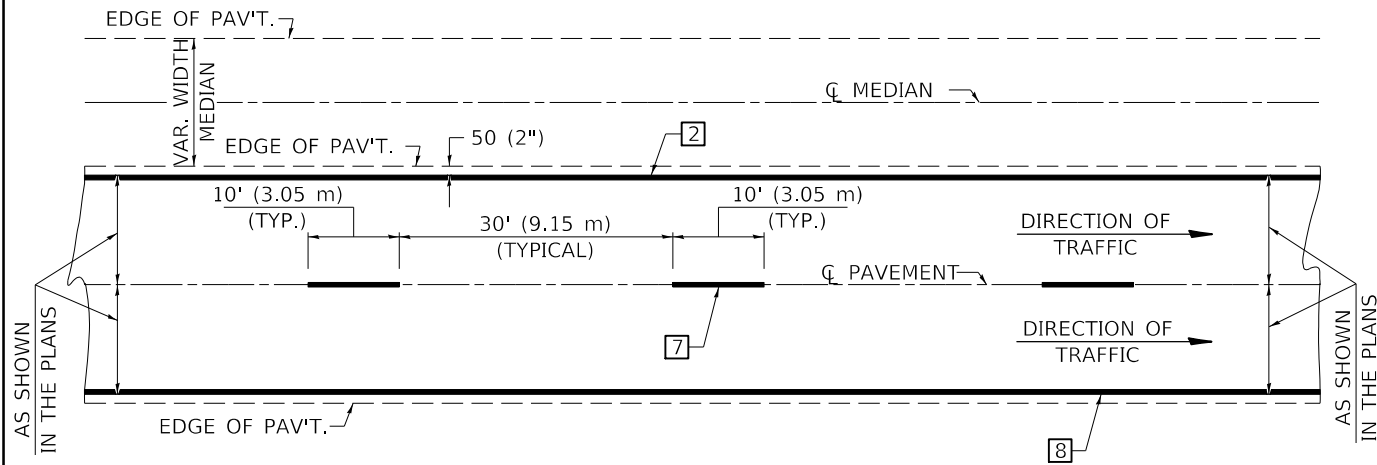

NOTE: PAVEMENT MARKINGS ARE TO BE EXTENDED THROUGH OMISSIONS WHEN APPLICABLE.

NOTE: SEE ARTICLES 780.04 & 781.03 FOR LOCATION OF STRIPES AND MARKERS RELATIVE TO EDGES OR JOINTS.

FOR RAISED REFLECTIVE PAVEMENT MARKERS, REFER TO STANDARD 781001.

TYPICAL PAVEMENT MARKING LEGEND

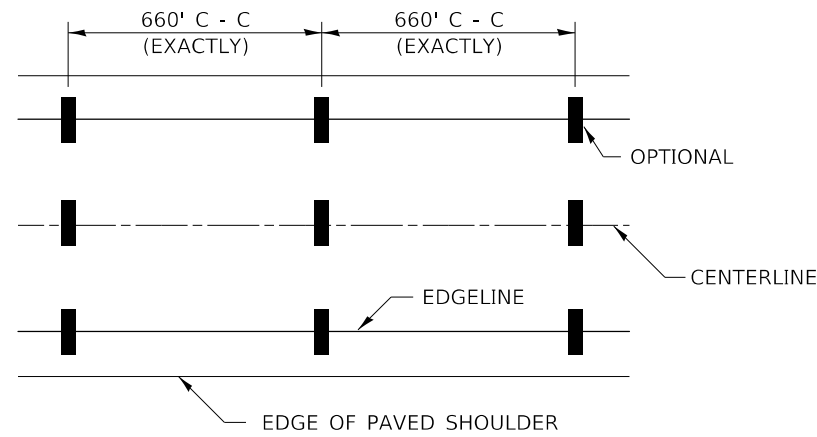

- 1 4" (100) SKIP-DASH (YELLOW)
- 2 4" (100) SOLID (YELLOW)
- 3 12" (300) DIAGONAL (YELLOW)
- 4 4" (100) DOUBLE YELLOW (NARROW)
- 5 RESERVED
- 6 RESERVED
- 7 4" (100) SKIP-DASH (WHITE)
- 8 4" (100) SOLID (WHITE)
- 9 12" (300) DIAGONAL (WHITE)
- 10 6" (150) SOLID (WHITE)
- 11 24" (600) STOP BAR (WHITE)
- 12 8" (200) SOLID (WHITE)
- 13 4" (100) LANE LINE EXTENSIONS (WHITE)

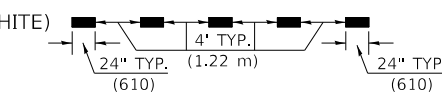
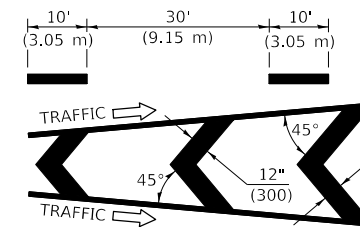
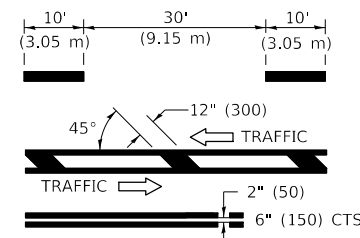

TYPICAL EXIT RAMP TERMINAL

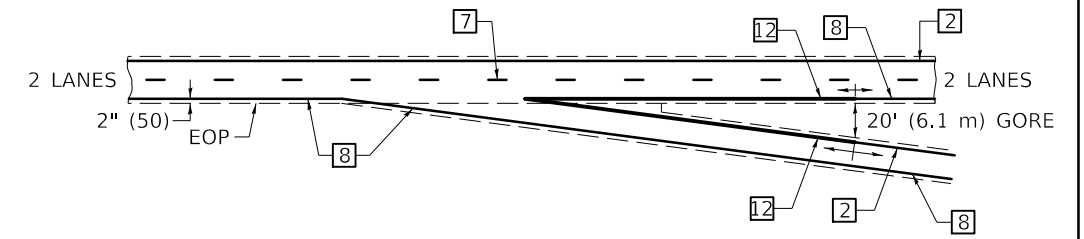

EXIT RAMP TERMINAL with EXCLUSIVE (auxiliary) LANE

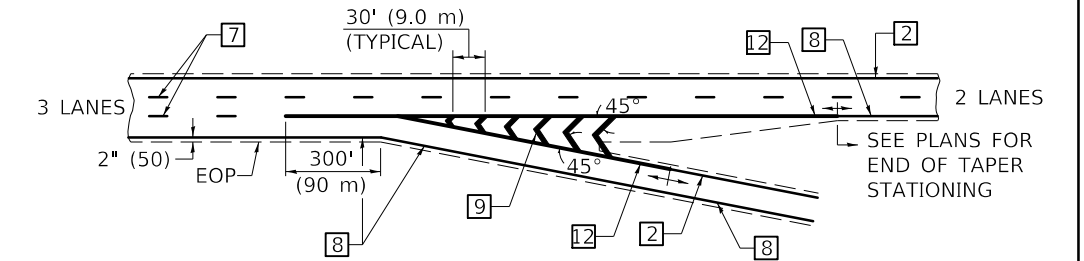

TYPICAL ENTRANCE RAMP TERMINAL

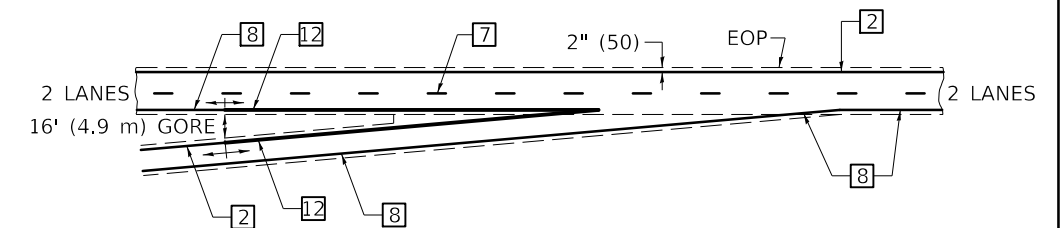

ENTRANCE RAMP TERMINAL with EXCLUSIVE LANE

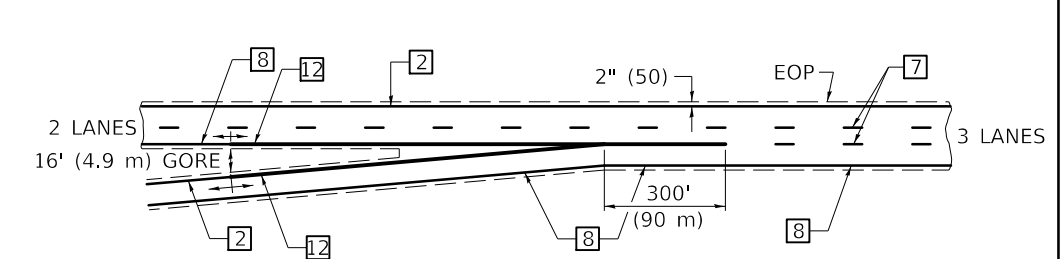

IT WILL BE NECESSARY TO HAVE A REPRESENTATIVE OF THE STATE POLICE PRESENT SO THAT THE ACCURACY OF MEASUREMENT CAN BE ATTESTED TO IN COURT.

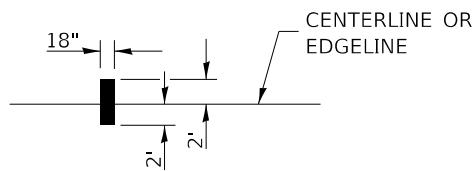

AERIAL SPEED CHECK ZONES

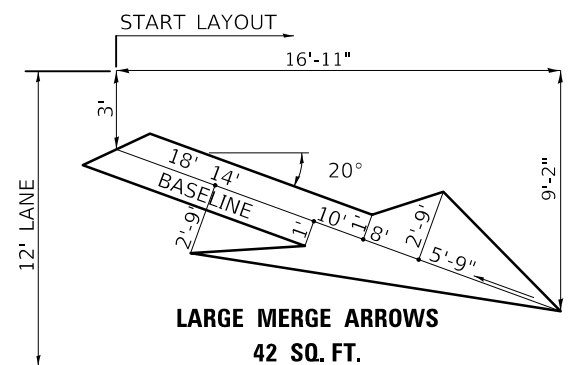

Note: All dimensions are in INCHES (millimeters) unless otherwise shown.

DISTRICT 5 DETAIL NO. 7800BBBB

USER NAME = farnhamba	DESIGNED -	REVISED - 11/06
PLOT SCALE = 40.0000 "/in.	DRAWN -	REVISED -
PLOT DATE = 10/15/2019	CHECKED -	REVISED -
	DATE -	REVISED -

**STATE OF ILLINOIS
DEPARTMENT OF TRANSPORTATION**

PAVEMENT MARKING (INTERSTATE & MULTI-LANE APPLICATIONS)

SCALE: SHEET 1 OF 1 SHEETS STA. TO STA.

F.A. RTE.	SECTION	COUNTY	TOTAL SHEETS	SHEET NO.
	**		45	45
CONTRACT NO. 46534				

MODEL: I:\MODEL\NAME: FILE: Name: Path: \\hmc\com\asda\illinois\pwr\DOT\Documents\DOT_Offices\District 5\Projects\0546534\CADD\Drawings\CD\Sheet\0546534-45-45-Detail.dgn