

Note:
Backfill within the limits of the paved surface to the top of culvert elevation shall be performed according to the special provision for Granular Culvert Backfill.

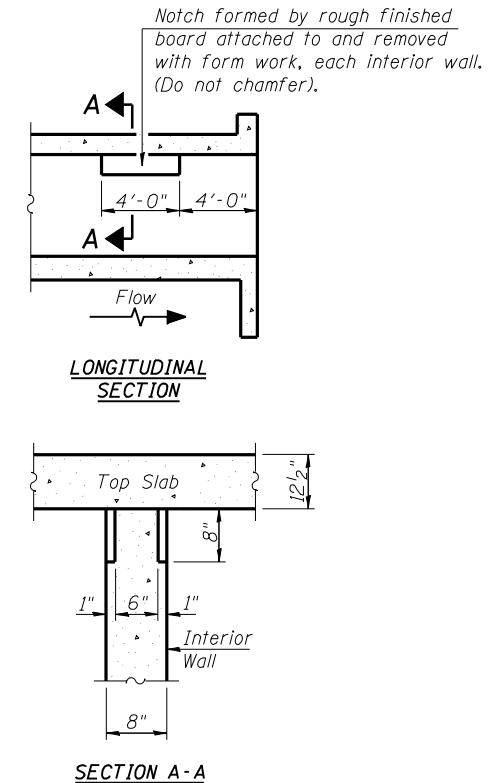

PHOEBE NESTING
SITE DETAILS
(Downstream End Only)

GENERAL NOTES

Layout of slope protection system may be varied to suit ground conditions in the field as directed by the Engineer. Precast alternate is not allowed.

STATION 367+20.00
BUILT 20 BY
STATE OF ILLINOIS
F.A.P. RT. 322 SEC. 11-13
LOADING HS20-44
STRUCTURE NO. 011-2504

NAME PLATE
See Std. 515001

TOTAL BILL OF MATERIAL

ITEM	UNIT	TOTAL
Stone Riprap, Class A4	Sq. Yd.	117
Filter Fabric	Sq. Yd.	117
Reinforcement Bars	Pound	91150
Name Plates	Each	1
Concrete Box Culverts	Cu. Yd.	523.7
Granular Culvert Backfill	Cu. Yd.	1537
Rock Fill-Foundation	Ton	739
Temporary Soil Retention System	Sq. Ft.	879