

**SECTION A-A**  
(Dimensions at RT L's to end of deck)

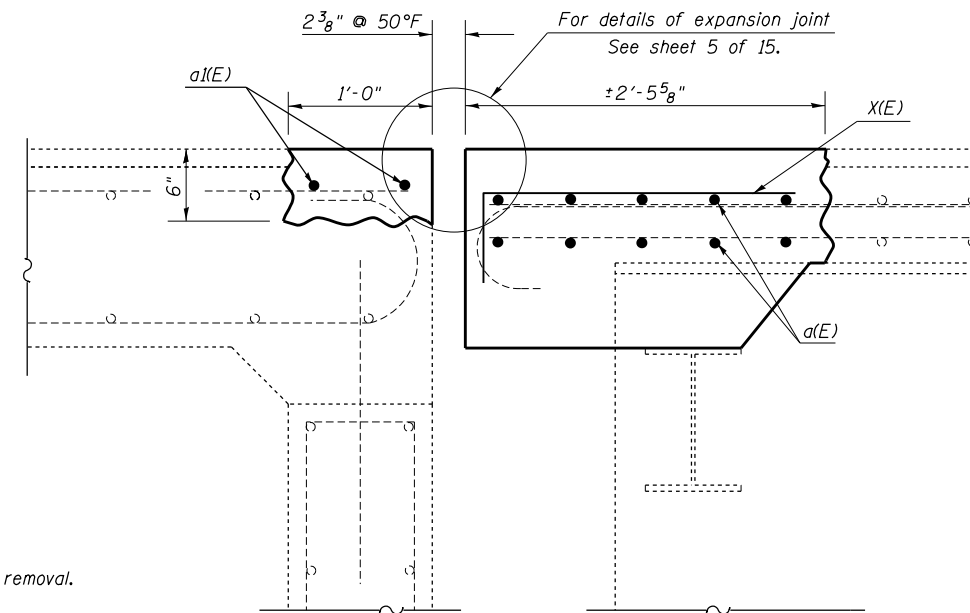

**SECTION B-B**  
(Dimensions at RT L's to end of deck)

Hatching indicates concrete removal.

○ Existing Reinforcement  
● Proposed Reinforcement

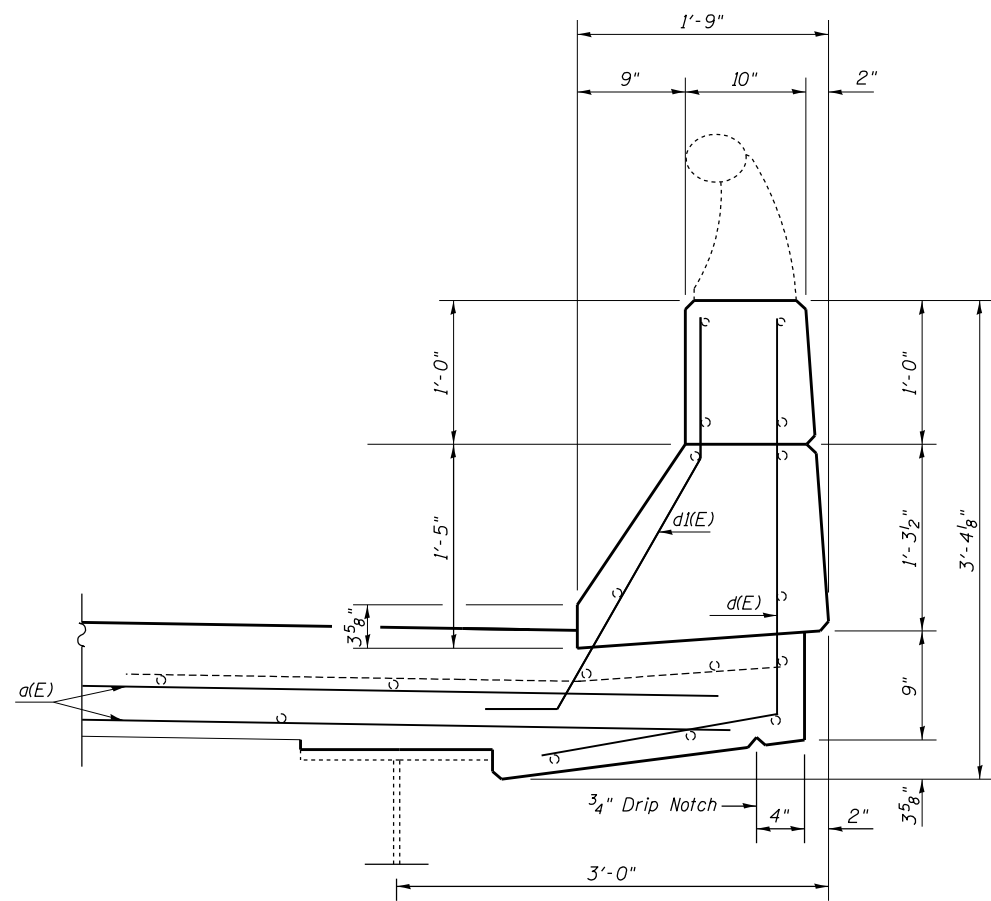

**SECTION THRU DECK PARAPET**

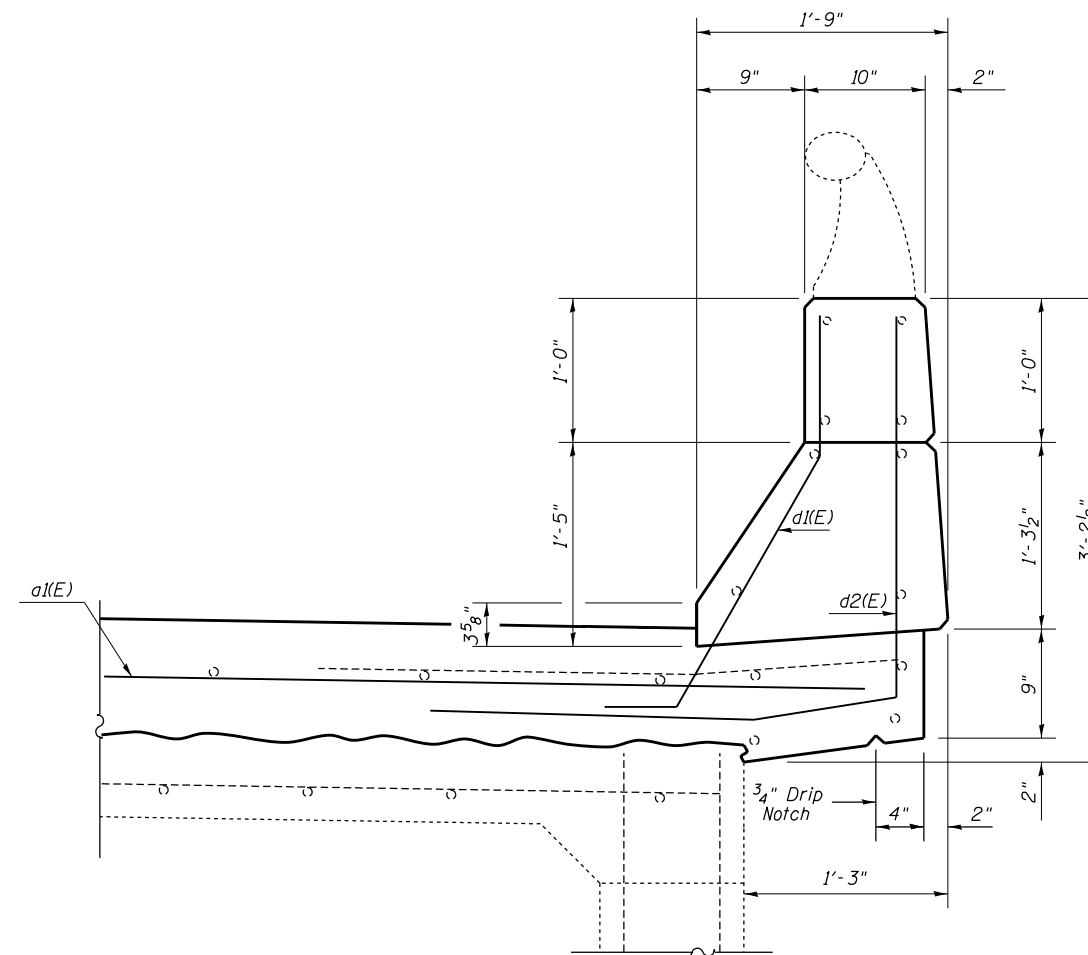

**SECTION THRU APPROACH PARAPET**

FILE NAME =	USER NAME = teasleyck	DESIGNED - DFZ	REVISED -
ci:\pw\work\p\idot\teasleyck\d0307638\074591-shr-brd\details-0580073.dgn		DRAWN - DFZ	REVISED -
Default	PLOT SCALE = 40.0000' / in.	CHECKED - KLB	REVISED -
	PLOT DATE = 10/29/2012	DATE - 7/23/12	REVISED -

**STATE OF ILLINOIS  
DEPARTMENT OF TRANSPORTATION**

**EXPANSION JOINT REPLACEMENT DETAILS  
SN. 058-0073**

SCALE: SHEET 4 OF 15 SHEETS STA. TO STA.

F.A. RTE.	SECTION	COUNTY	TOTAL SHEETS	SHEET NO.
• 07	BRIDGE REPAIRS 2013-3	MACON	28	17
• FAI 72, FAU 7354			CONTRACT NO.	74591
ILLINOIS FED. AID PROJECT				