

MATCH LINE SEE SHEET 100

MATCH LINE SEE SHEET 102

- NOTE:**
1. ALL DIMENSIONS ARE TO THE EDGE OF PAVEMENT UNLESS OTHERWISE NOTED.
  2. PAVEMENT MARKING CURVE RADIUS IS 3.0' UNLESS OTHERWISE NOTED.
  3. ALL PAVEMENT MARKINGS SHALL BE THERMOPLASTIC, UNLESS OTHERWISE NOTED.

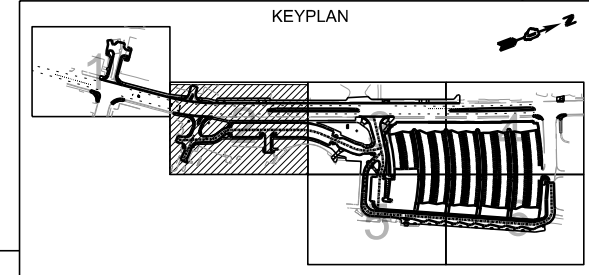

FILE NAME =	USER NAME = bweich	DESIGNED - BMW	REVISED -
\\CBELSRV1\cbbel\df\t\WBK\150077.2\Civil\150077.2_02.sht	PVM-150077.2_02.sht	DRAWN - PWN	REVISED -
Default	PLOT SCALE = 48"	CHECKED - BMW	REVISED -
	PLOT DATE = 11/7/2017	DATE - 11/7/2017	REVISED -

**STATE OF ILLINOIS  
DEPARTMENT OF TRANSPORTATION**

**AURORA TRANSIT CENTER IMPROVEMENTS  
PAVEMENT MARKING & SIGNAGE PLAN**

SCALE: 48" SHEET OF 254 SHEETS STA. TO STA.

F.A.U. RTE.	SECTION	COUNTY	TOTAL SHEETS	SHEET NO.
2503	16-00313-00-MS	KANE	254	101
CONTRACT NO. 61E18				
ILLINOIS FED. AID PROJECT				

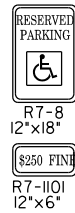

TYPICAL DISABLED PARKING SIGN

NOTE:

1. ALL DIMENSIONS ARE TO THE EDGE OF PAVEMENT UNLESS OTHERWISE NOTED.
2. PAVEMENT MARKING CURVE RADIUS IS 3.0' UNLESS OTHERWISE NOTED.
3. ALL PAVEMENT MARKINGS SHALL BE THERMOPLASTIC, UNLESS OTHERWISE NOTED.

**RIVEREDGE PARK  
(CITY OF AURORA PROPERTY)**

**RIVEREDGE PARK  
(CITY OF AURORA PROPERTY)**

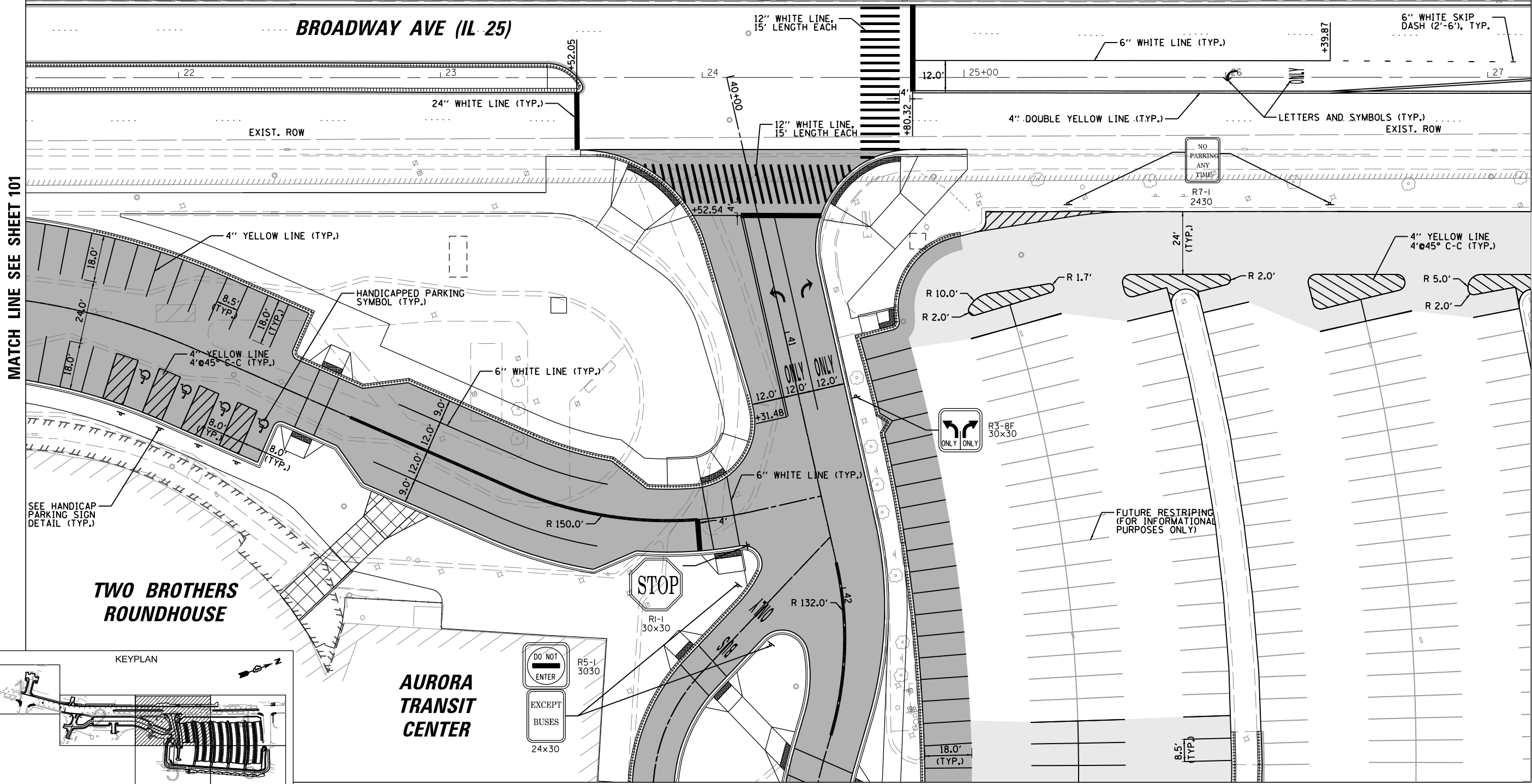

MATCH LINE SEE SHEET 101

MATCH LINE SEE SHEET 103

MATCH LINE SEE SHEET 104

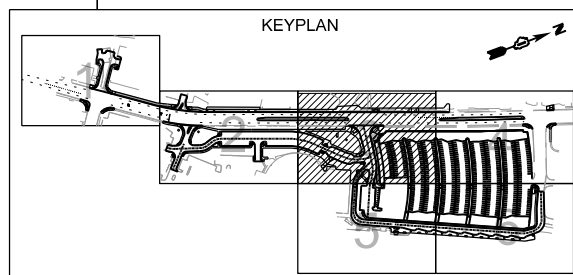

FILE NAME = N:\WBK\150077.2\Civil1\PVM-150077.2.03.sht	USER NAME = bweich	DESIGNED - BMW	REVISED -
Default	PLOT SCALE = 48"	DRAWN - PWN	REVISED -
	PLOT DATE = 12/4/2017	CHECKED - BMW	REVISED -
		DATE - 12/4/2017	REVISED -

STATE OF ILLINOIS  
DEPARTMENT OF TRANSPORTATION

AURORA TRANSIT CENTER IMPROVEMENTS  
PAVEMENT MARKING & SIGNAGE PLAN

SCALE: 48" SHEET OF 254 SHEETS STA. TO STA.

F.A.U. RTE. 2503	SECTION 16-00313-00-MS	COUNTY KANE	TOTAL SHEETS 254	SHEET NO. 102
CONTRACT NO. 61E18				
ILLINOIS FED. AID PROJECT				

**RIVEREDGE PARK  
(CITY OF AURORA PROPERTY)**

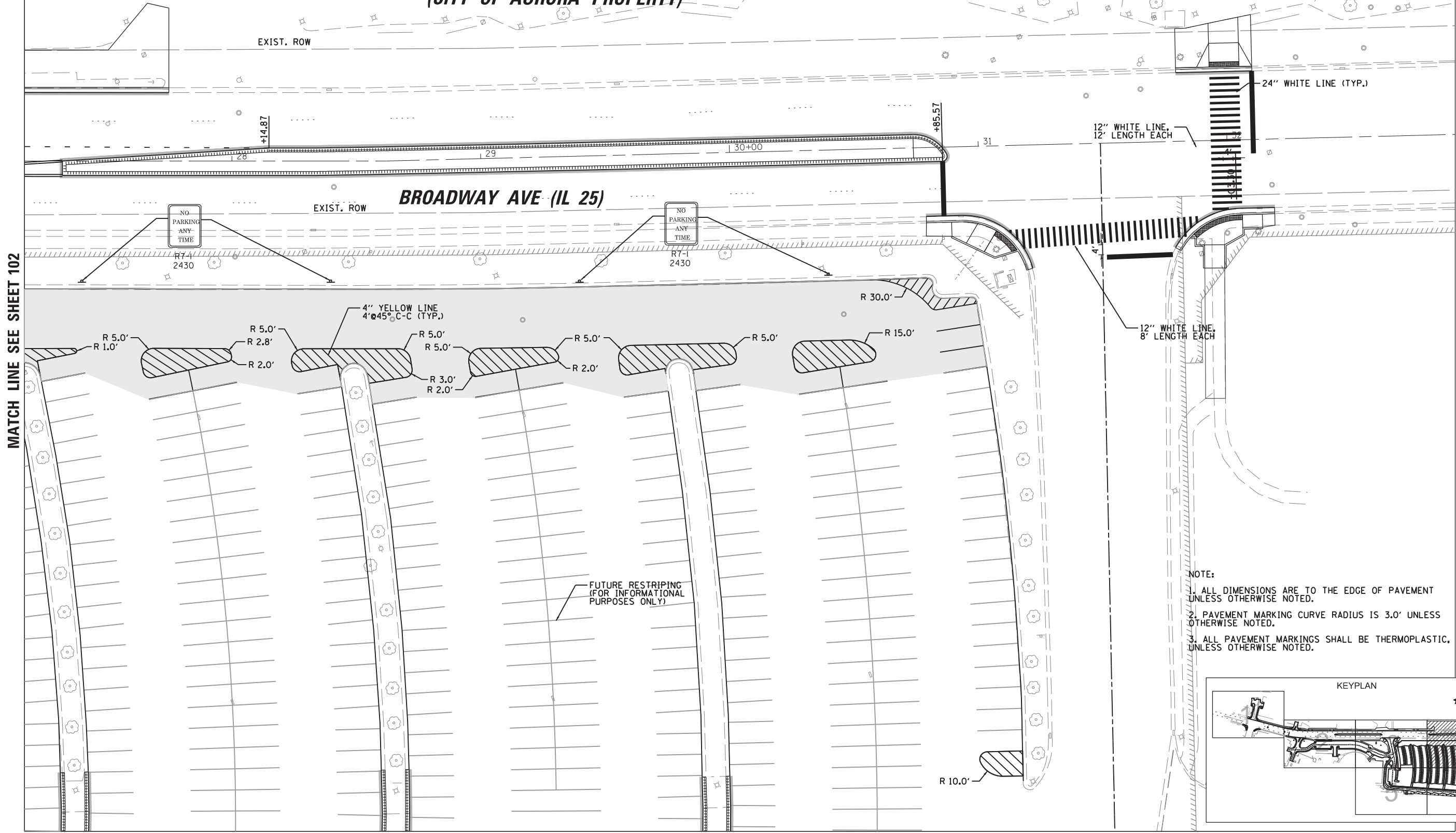
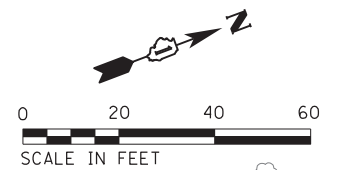

- NOTE:**
1. ALL DIMENSIONS ARE TO THE EDGE OF PAVEMENT UNLESS OTHERWISE NOTED.
  2. PAVEMENT MARKING CURVE RADIUS IS 3.0' UNLESS OTHERWISE NOTED.
  3. ALL PAVEMENT MARKINGS SHALL BE THERMOPLASTIC, UNLESS OTHERWISE NOTED.

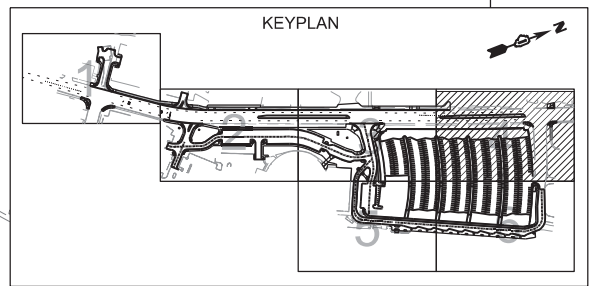

FILE NAME = N:\WBK\150077.2\Civil\150077.2_04.sht	USER NAME = bweich	DESIGNED - BMW	REVISED -
Default	PLOT SCALE = 48"	DRAWN - PWN	REVISED -
	PLOT DATE = 10/16/2017	CHECKED - BMW	REVISED -
		DATE - 10/16/2017	REVISED -

**STATE OF ILLINOIS  
DEPARTMENT OF TRANSPORTATION**

**AURORA TRANSIT CENTER IMPROVEMENTS  
PAVEMENT MARKING & SIGNAGE PLAN**

SCALE: 48" SHEET OF 254 SHEETS STA. TO STA.

F.A.U. RTE.	SECTION	COUNTY	TOTAL SHEETS	SHEET NO.
2503	16-00313-00-MS	KANE	254	103
CONTRACT NO. 61E18				
ILLINOIS FED. AID PROJECT				

MATCH LINE SEE SHEET 102

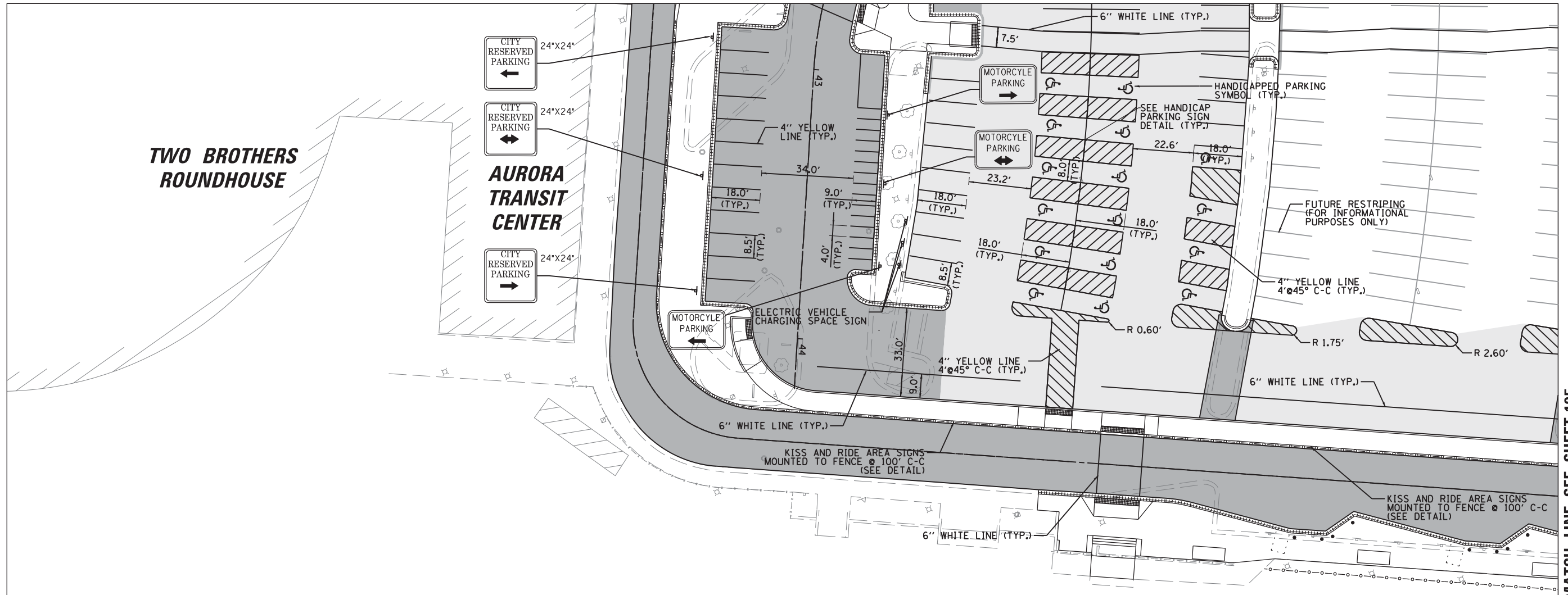

MATCH LINE SEE SHEET 105

**NOTE:**

1. ALL DIMENSIONS ARE TO THE EDGE OF PAVEMENT UNLESS OTHERWISE NOTED.
2. PAVEMENT MARKING CURVE RADIUS IS 3.0' UNLESS OTHERWISE NOTED.
3. ALL PAVEMENT MARKINGS SHALL BE THERMOPLASTIC, UNLESS OTHERWISE NOTED.

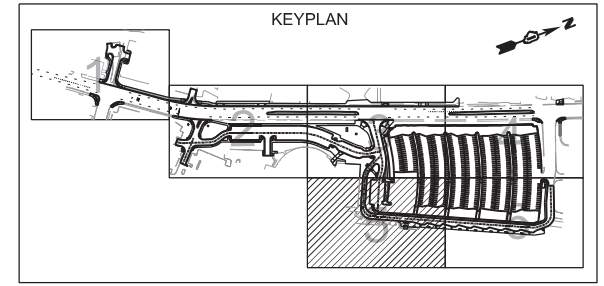
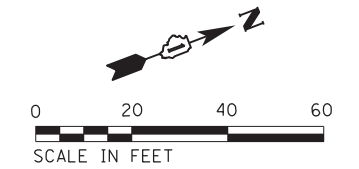
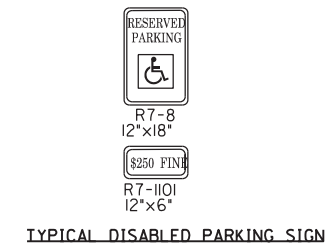

FILE NAME = N:\WBK\150077.2\Civil\150077.2.05.sht	USER NAME = bweich	DESIGNED - BMW	REVISED -	<b>STATE OF ILLINOIS DEPARTMENT OF TRANSPORTATION</b>	<b>AURORA TRANSIT CENTER IMPROVEMENTS PAVEMENT MARKING &amp; SIGNAGE PLAN</b>	F.A.U. R.T.E.	SECTION	COUNTY	TOTAL SHEETS	SHEET NO.	
Default	PLOT SCALE = 48'	DRAWN - PWN	REVISED -			2503	16-00313-00-MS	KANE	254	104	
	PLOT DATE = 10/16/2017	CHECKED - BMW	REVISED -			CONTRACT NO. 61E18					
		DATE - 10/16/2017	REVISED -			ILLINOIS FED. AID PROJECT					

MATCH LINE SEE SHEET 103

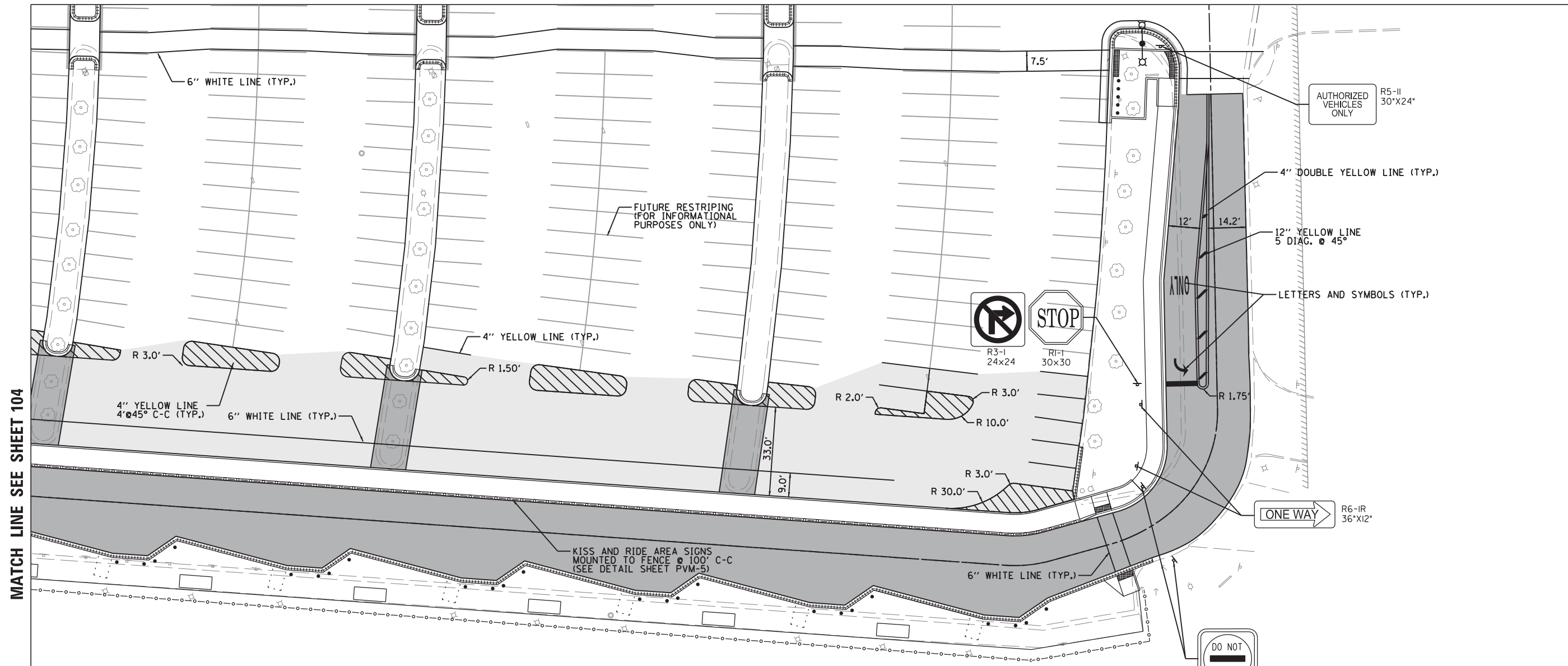

MATCH LINE SEE SHEET 104

- NOTE:**
1. ALL DIMENSIONS ARE TO THE EDGE OF PAVEMENT UNLESS OTHERWISE NOTED.
  2. PAVEMENT MARKING CURVE RADIUS IS 3.0' UNLESS OTHERWISE NOTED.
  3. ALL PAVEMENT MARKINGS SHALL BE THERMOPLASTIC, UNLESS OTHERWISE NOTED.

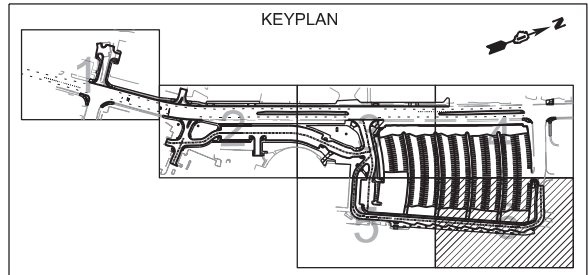
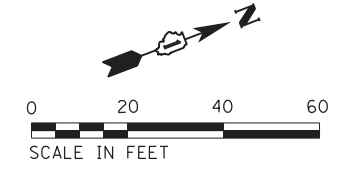

FILE NAME = N:\WBK\150077.2\Civil1\PVM-150077.2.06.sht	USER NAME = bweich	DESIGNED - BMW	REVISED -
		DRAWN - PWN	REVISED -
	PLOT SCALE = 48"	CHECKED - BMW	REVISED -
	PLOT DATE = 10/16/2017	DATE - 10/16/2017	REVISED -

**STATE OF ILLINOIS  
DEPARTMENT OF TRANSPORTATION**

**AURORA TRANSIT CENTER IMPROVEMENTS  
PAVEMENT MARKING & SIGNAGE PLAN**

SCALE: 48" SHEET OF 254 SHEETS STA. TO STA.

F.A.U. RTE.	SECTION	COUNTY	TOTAL SHEETS	SHEET NO.
2503	16-00313-00-MS	KANE	254	105
				CONTRACT NO. 61E18
ILLINOIS FED. AID PROJECT				

- NOTES:
1. ALL PAVEMENT MARKINGS SHALL BE THERMOPLASTIC OF THE SPECIFIED COLOR.



RESERVED PARKING SIGN R7-1101, 12x24

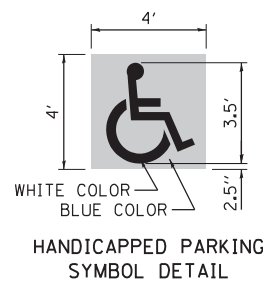

HANDICAPPED PARKING SYMBOL DETAIL

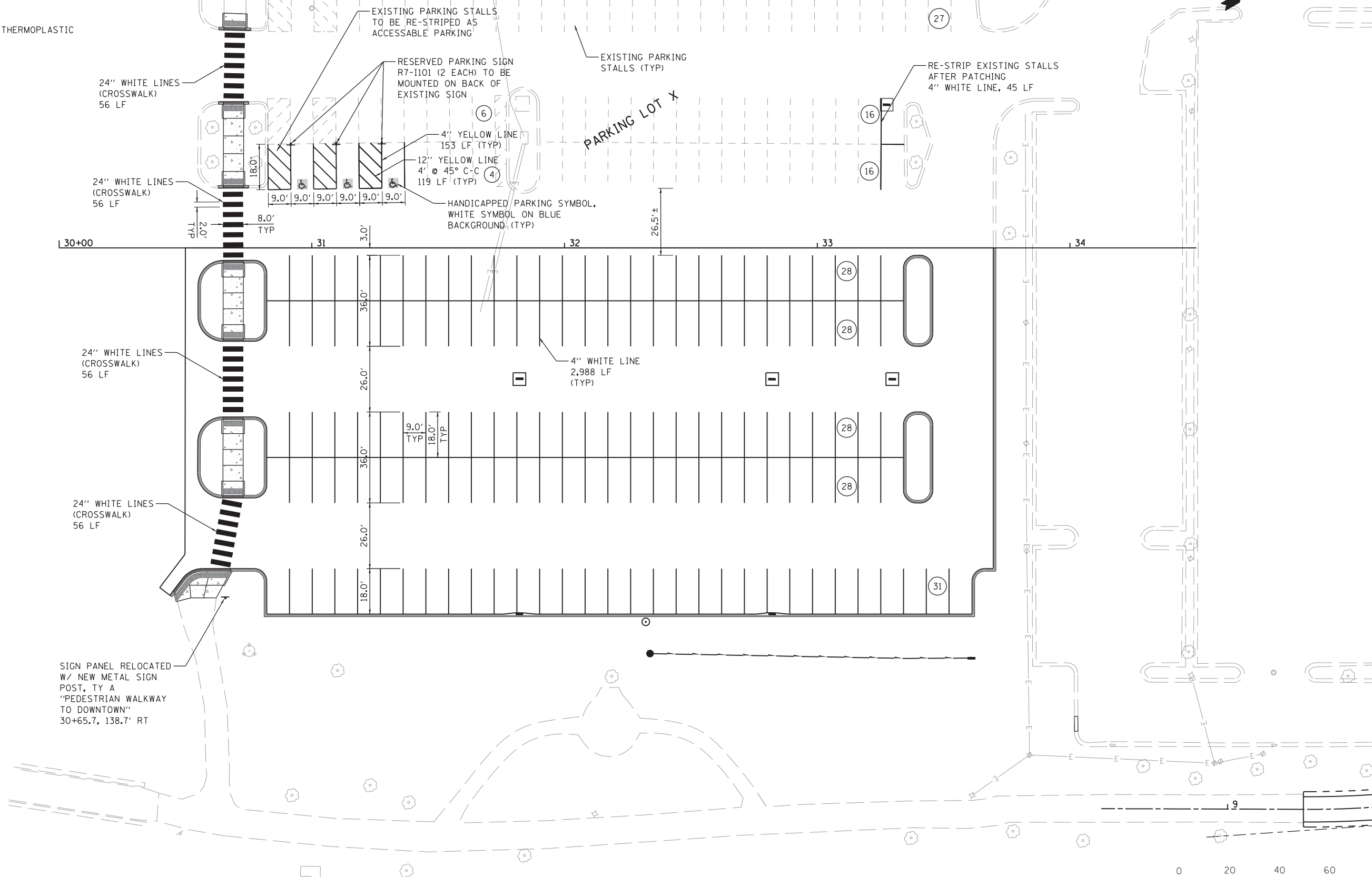

FILE NAME = W:\Projects\2016\160194\_ATCPhaseII\cadd\Civil\Drawn\Shit\PMK\_01.dgn

**WBK engineering**  
 WBK ENGINEERING, LLC  
 116 WEST MAIN STREET, SUITE 201  
 ST. CHARLES, ILLINOIS 60174  
 (630) 443-7755

USER NAME = nparris	DESIGNED - MNB	REVISED -
PLOT SCALE = 1:40	DRAWN - NDP	REVISED -
PLOT DATE = 10/17/2017	CHECKED - MNB	REVISED -
	DATE - 10/18/17	REVISED -

**STATE OF ILLINOIS  
 DEPARTMENT OF TRANSPORTATION**

**PAVEMENT MARKING & SIGNING PLAN  
 PARKING LOT X**

SCALE: 1"=20' SHEET NO. 7 OF 8 SHEETS STA. TO STA.

F.A.U. RTE.	SECTION	COUNTY	TOTAL SHEETS	SHEET NO.
2503	16-00313-00-MS	KANE	254	106
CONTRACT NO. 61E18				
ILLINOIS FED. AID PROJECT				

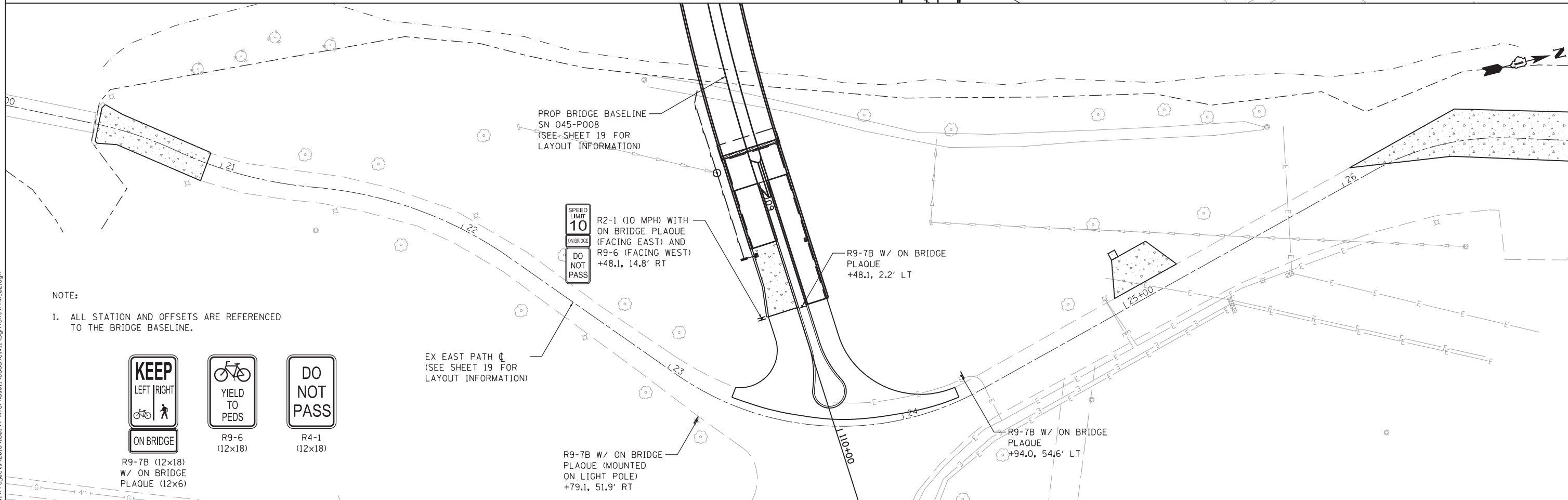
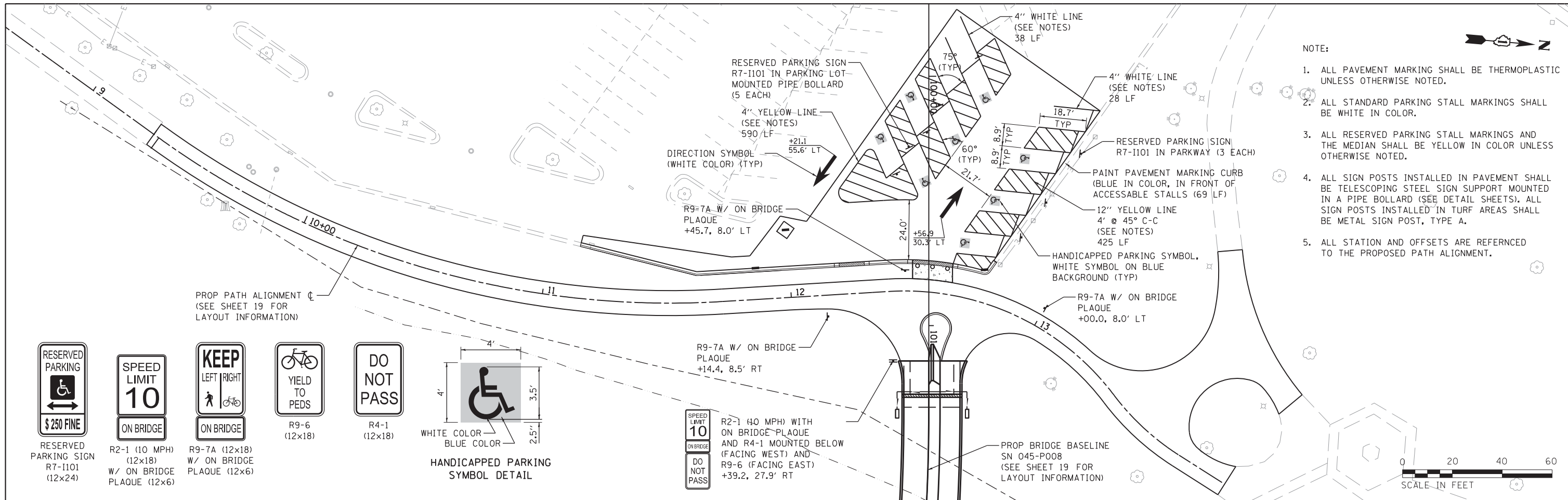

# TRAFFIC SIGNAL LEGEND

(NOT TO SCALE)

ITEM	EXISTING	PROPOSED	ITEM	EXISTING	PROPOSED	ITEM	EXISTING	PROPOSED
CONTROLLER CABINET			HANDHOLE -SQUARE -ROUND			SIGNAL HEAD -(P) PROGRAMMABLE SIGNAL HEAD		
COMMUNICATION CABINET			HEAVY DUTY HANDHOLE -SQUARE -ROUND			SIGNAL HEAD WITH BACKPLATE -(P) PROGRAMMABLE SIGNAL HEAD -(RB) RETROREFLECTIVE BACKPLATE		
MASTER CONTROLLER			DOUBLE HANDHOLE			PEDESTRIAN SIGNAL HEAD AT RAILROAD INTERSECTIONS		
MASTER MASTER CONTROLLER			JUNCTION BOX			PEDESTRIAN SIGNAL HEAD WITH COUNTDOWN TIMER		
UNINTERRUPTABLE POWER SUPPLY			RAILROAD CANTILEVER MAST ARM			ILLUMINATED SIGN "NO LEFT TURN"/"NO RIGHT TURN"		
SERVICE INSTALLATION -(P) POLE MOUNTED			RAILROAD FLASHING SIGNAL			NUMBER OF CONDUCTORS, ELECTRIC CABLE NO. 14, UNLESS NOTED OTHERWISE, ALL DETECTOR LOOP CABLE TO BE SHIELDED		
SERVICE INSTALLATION -(G) GROUND MOUNTED -(GM) GROUND MOUNTED METERED			RAILROAD CROSSING GATE			GROUND CABLE IN CONDUIT, NO. 6 SOLID COPPER (GREEN)		
TELEPHONE CONNECTION			RAILROAD CROSSBUCK			ELECTRIC CABLE IN CONDUIT, TRACER NO. 14 1/C		
STEEL MAST ARM ASSEMBLY AND POLE			RAILROAD CONTROLLER CABINET			COAXIAL CABLE		
ALUMINUM MAST ARM ASSEMBLY AND POLE			UNDERGROUND CONDUIT (UC), GALVANIZED STEEL			VENDOR CABLE		
STEEL COMBINATION MAST ARM ASSEMBLY AND POLE WITH LUMINAIRE			TEMPORARY SPAN WIRE, TETHER WIRE, AND CABLE			COPPER INTERCONNECT CABLE, NO. 18, 3 PAIR TWISTED, SHIELDED		
SIGNAL POST -(BM) BARREL MOUNTED - TEMPORARY			SYSTEM ITEM			FIBER OPTIC CABLE -NO. 62.5/125, MM12F -NO. 62.5/125, MM12F SM12F -NO. 62.5/125, MM12F SM24F		
WOOD POLE			INTERSECTION ITEM			GROUND ROD -(C) CONTROLLER -(M) MAST ARM -(P) POST -(S) SERVICE		
GUY WIRE			REMOVE ITEM					
SIGNAL HEAD			RELOCATE ITEM					
SIGNAL HEAD WITH BACKPLATE			ABANDON ITEM					
SIGNAL HEAD OPTICALLY PROGRAMMED			CONTROLLER CABINET AND FOUNDATION TO BE REMOVED					
FLASHER INSTALLATION -(FS) SOLAR POWERED			MAST ARM POLE AND FOUNDATION TO BE REMOVED					
PEDESTRIAN SIGNAL HEAD			SIGNAL POST AND FOUNDATION TO BE REMOVED					
PEDESTRIAN PUSH BUTTON -(APS) ACCESSIBLE PEDESTRIAN PUSH BUTTON			DETECTOR LOOP, TYPE I					
RADAR DETECTION SENSOR			PREFORMED DETECTOR LOOP					
VIDEO DETECTION CAMERA			SAMPLING (SYSTEM) DETECTOR					
RADAR/VIDEO DETECTION ZONE			INTERSECTION AND SAMPLING (SYSTEM) DETECTOR					
PAN, TILT, ZOOM (PTZ) CAMERA			QUEUE AND SAMPLING (SYSTEM) DETECTOR					
EMERGENCY VEHICLE LIGHT DETECTOR			WIRELESS DETECTOR SENSOR					
CONFIRMATION BEACON			WIRELESS ACCESS POINT					
WIRELESS INTERCONNECT								
WIRELESS INTERCONNECT RADIO REPEATER								

TS SHT NO. 1

FILE NAME = ts05.dgn	USER NAME = lgyeo	DESIGNED - IP	REVISED -	<b>STATE OF ILLINOIS DEPARTMENT OF TRANSPORTATION</b>	<b>DISTRICT ONE STANDARD TRAFFIC SIGNAL DESIGN DETAILS</b>	F.A.U. RTE. 2503	SECTION 16-00313-00-MS	COUNTY KANE	TOTAL SHEETS 254	SHEET NO. 108
Default	PLOT SCALE = 5/8"=1'-0"	DRAWN - LP	REVISED -		SCALE: NONE	TS-05			CONTRACT NO.	
	PLOT DATE = 9/29/2016	CHECKED - LP	REVISED -		SHEET 1	OF 7 SHEETS			ILLINOIS FED. AID PROJECT	
		DATE - 9/29/2016	REVISED -		STA.	TO STA.				



**LOOP DETECTOR NOTES**

1. EACH PAIR OF LOOP WIRES SHALL BE PLACED IN A SEPARATE EMPTY COILABLE NONMETALLIC CONDUIT FROM THE EDGE OF PAVEMENT TO THE HANDHOLE. SPACING BETWEEN THE HOLES DRILLED IN THE PAVEMENT SHALL NOT BE LESS THAN 6" (150 mm). EMPTY COILABLE NONMETALLIC CONDUIT SHALL BE INCLUDED IN THE COST OF THE LOOP WIRE.
2. THE NUMBER OF LOOP TURNS SHALL BE AS RECOMMENDED BY THE AMPLIFIER MANUFACTURER. ALL ADJACENT SIDES OF THE LOOPS SHALL BE INSTALLED IN SUCH A WAY THAT THE CURRENT FLOW IS IN THE SAME DIRECTION TO REINFORCE ITS MAGNETIC FIELDS FOR SMALL VEHICLE DETECTION.
3. EACH LOOP LEAD-IN SHALL BE IDENTIFIED AND PERMANENTLY TAGGED IN THE HANDHOLE. EACH LEAD-IN CABLE TAG SHALL INDICATE THE LOCATION OF THE LOOP, LOOP ROTATION (CLOCKWISE/COUNTERCLOCKWISE), LOOP LEAD-IN DIRECTION (IN OR OUT), LOOP CABLE NUMBER AND LOCATION IN CABINET, AND NUMBER OF TURNS IN THE DETECTOR LOOPS IN WATER PROOF INK AS INDICATED ON THE DISTRICT 1 STANDARD TRAFFIC SIGNAL DESIGN DETAIL. THE CONTRACTOR SHALL MARK LOOP LOCATIONS ON RECORD DRAWINGS AND PRESENT TO THE ENGINEER AFTER FINAL INSPECTION. LOOPS SHALL BE MARKED BY LANE AND LOOP NUMBER. SEE DETAIL BELOW.
4. ALL LOOP CABLE SHALL BE FASTENED WITH PLASTIC TIE WRAP TO THE HANDHOLE HOOKS.
5. IN ASPHALT PAVEMENT, LOOPS SHOULD BE PLACED IN THE BINDER AND DIVEHOLES MARKED AT THE CURB WITH A SAW-CUT. THE SAW-CUT SHALL BE CUT IN ACCORDANCE WITH LOCAL AND E.P.A. DUST CONTROL REQUIREMENTS. DETECTOR LOOP(S) SHALL NOT BE INSTALLED IN WET CONDITIONS AND THE SAW-CUTS MUST BE FREE OF DEBRIS AND RESIDUE SUCH AS DUST AND WATER WHICH IS TO BE ACHIEVED BY THE USE OF COMPRESSED AIR, WIRE BRUSHING AND HEAT DRYING ACCORDING TO SEALANT MANUFACTURER REQUIREMENTS. THE DETECTOR WIRE SHALL BE HELD IN PLACE BY THE USE OF FORM WEDGES. WEDGES SHALL BE SPACED NO MORE THAN 18" (450 mm) APART.
6. LOOP SPLICES SHALL BE SOLDERED USING A SOLDERING IRON. BLOW TORCHES OR OTHER DEVICES WHICH OXIDIZE COPPER CABLE SHALL NOT BE ALLOWED FOR SOLDERING OPERATIONS. SEE DETAIL BELOW RIGHT.
7. PREFORMED DETECTOR LOOPS SHALL BE USED, AS SHOWN ON THE PLANS, WHERE NEW CONCRETE PAVEMENT IS PROPOSED. THE INSTALLATION OF PREFORMED LOOPS SHALL BE IN ACCORDANCE WITH THE DISTRICT 1 SPECIFICATIONS OR AS DIRECTED BY THE ENGINEER.

**LOOP LEAD-IN CABLE TAG**

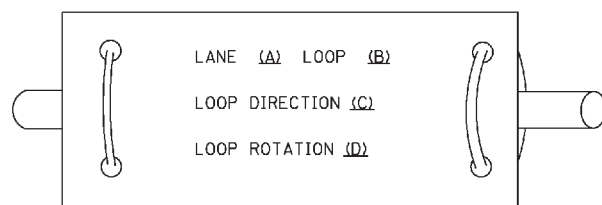

- A. LANE 1 IS THE LANE CLOSEST TO THE CENTERLINE OF THE ROADWAY
- B. LOOP #1 IS THE LOOP IN THE LANE CLOSEST TO THE INTERSECTION.
- C. LABEL LOOP CABLE "IN" OR LOOP CABLE "OUT".
- D. LABEL LOOP CABLE CLOCKWISE OR LOOP CABLE COUNTERCLOCKWISE.

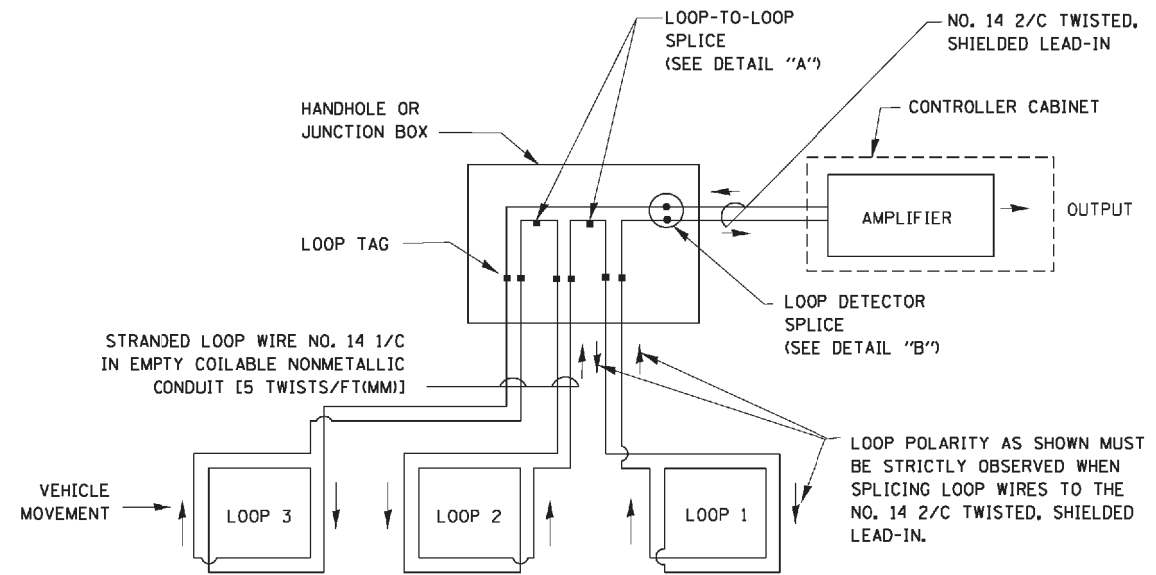

**DETECTOR LOOP WIRING SCHEMATIC**

- LOOPS SHALL BE SPLICED IN SERIES.
- SAW-CUTS SHALL BE A MINIMUM WIDTH OF 5/16" (8 mm).
- SAW-CUT DEPTHS SHALL BE 3" (75 mm). IF IN CONCRETE, THE SAW-CUT DEPTH SHALL BE TO THE TOP OF THE REINFORCEMENT.
- LOOP CORNERS SHALL BE DRILLED WITH A 2" (50 mm) DIAMETER CORE.

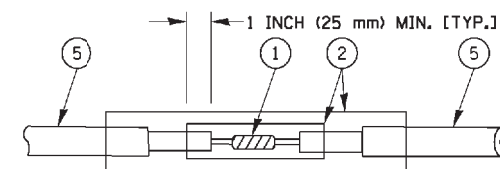

DETAIL "A"  
LOOP-TO-LOOP SPLICE

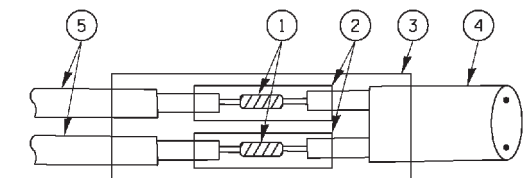

DETAIL "B"  
LOOP-TO-CONTROLLER SPLICE

**TYPE I LOOP**

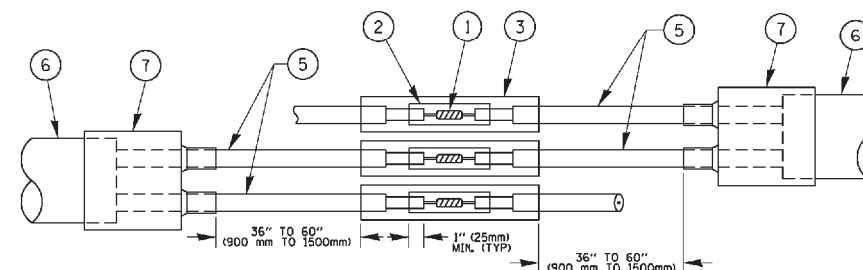

DETAIL "A"  
LOOP-TO-LOOP SPLICE

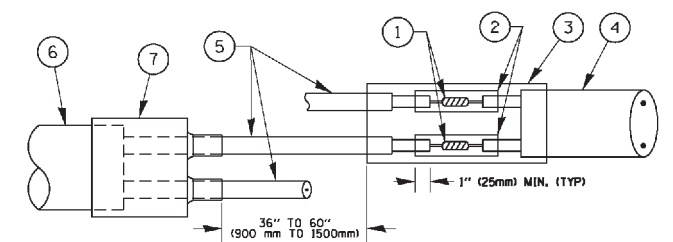

DETAIL "B"  
LOOP-TO-CONTROLLER SPLICE

**PREFORMED LOOP**

**LOOP DETECTOR SPLICE**

- 1 WESTERN UNION SPLICE SOLDERED WITH ROSIN CORE FLUX. ALL EXPOSED SURFACES OF THE SOLDER SHALL BE SMOOTH. THE WESTERN UNION SPLICES SHALL BE STAGGERED.
- 2 WCSMW 30/100 HEAT SHRINK TUBE, MINIMUM LENGTH 3" (75 mm), UNDERWATER GRADE.
- 3 WCS 200/750 HEAT SHRINK TUBE, MINIMUM LENGTH 6" (150 mm), UNDERWATER GRADE.
- 4 NO. 14 2/C TWISTED, SHIELDED CABLE.
- 5 LOOP CONDUCTOR WITH FLEXIBLE PLASTIC TUBE.
- 6 PREFORMED LOOP
- 7 XL POLYOLEFIN 2 CONDUCTOR BREAKOUT SEALS. TYCO CBR-2 OR APPROVED EQUAL

TS SHT NO. 2

FILE NAME =	USER NAME = foatemj	DESIGNED - DAD	REVISED - DAG 1-1-14	<b>STATE OF ILLINOIS DEPARTMENT OF TRANSPORTATION</b>	<b>DISTRICT ONE STANDARD TRAFFIC SIGNAL DESIGN DETAILS</b>	F.A.U. RTE. 2503	SECTION 16-00313-00-MS	COUNTY KANE	TOTAL SHEETS 254	SHEET NO. 109	
ca:\pwwork\pwwork\foatemj\d0188315\ts05.dgn	DRAWN - BCK	CHECKED - DAD	REVISED -			SCALE: NONE	SHEET NO. 2 OF 7 SHEETS	STA. TO STA.	<b>TS-05</b>		CONTRACT NO.
PLOT SCALE = 5/8,0000' / in.	DATE - 10-28-09	DATE - 10-28-09	REVISED -			FED. ROAD DIST. NO. 1 ILLINOIS FED. AID PROJECT					
PLOT DATE = 1/13/2014											

**TRAFFIC SIGNAL MAST ARM AND SIGNAL POST  
MAST ARM MOUNTED SIGNALS IN EXISTING, PROPOSED OR  
FUTURE SIDEWALK/BICYCLE PATH AREA. INTERSECTION SHOWN  
WITH PEDESTRIAN SIGNALS AND PEDESTRIAN PUSHBUTTON DETECTORS.**

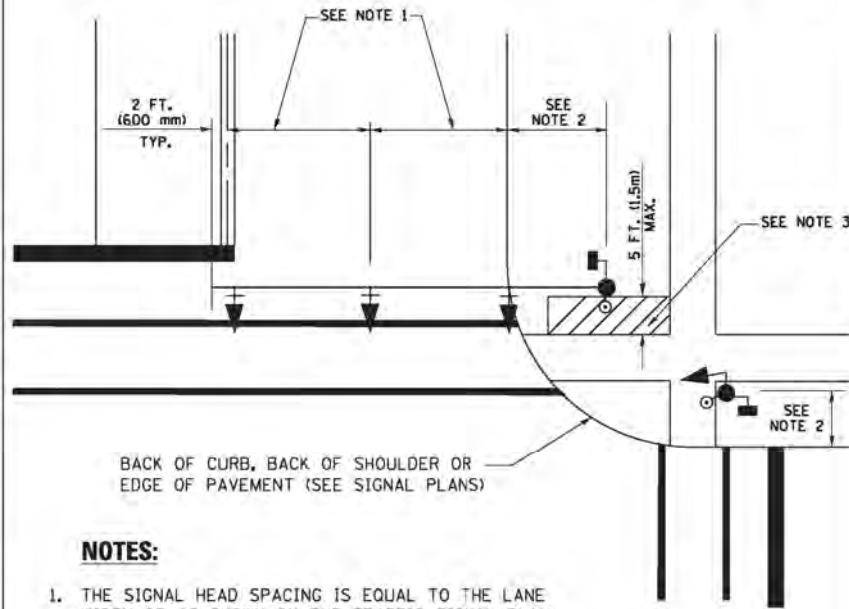

**NOTES:**

1. THE SIGNAL HEAD SPACING IS EQUAL TO THE LANE WIDTH OR AS SHOWN ON THE TRAFFIC SIGNAL PLAN.
2. REFER TO THE TRAFFIC SIGNAL EQUIPMENT OFFSET TABLE.
3. PROVIDE A LEVEL ALL-WEATHER SURFACE (CONCRETE SIDEWALK, ASPHALT BICYCLE PATH SURFACE OR MATCHING MATERIAL TO THE ADJACENT SURFACE) UP TO THE MAST ARM SHAFT OR THE SIGNAL POST.
4. THE FACE OF THE PEDESTRIAN PUSHBUTTON SHALL BE PARALLEL TO THE CROSSWALK TO BE USED.
5. THE LOCATIONS AND INSTALLATION OF PEDESTRIAN SIGNAL HEADS AND PEDESTRIAN PUSHBUTTONS SHALL MEET THE REQUIREMENTS OF THE MUTCD AND INFORMATION FOUND IN THE "AMERICANS WITH DISABILITIES ACT ACCESSIBILITY GUIDELINES FOR BUILDINGS AND FACILITIES."

**PEDESTRIAN SIGNAL POST  
AND  
PEDESTRIAN PUSH BUTTON POST**

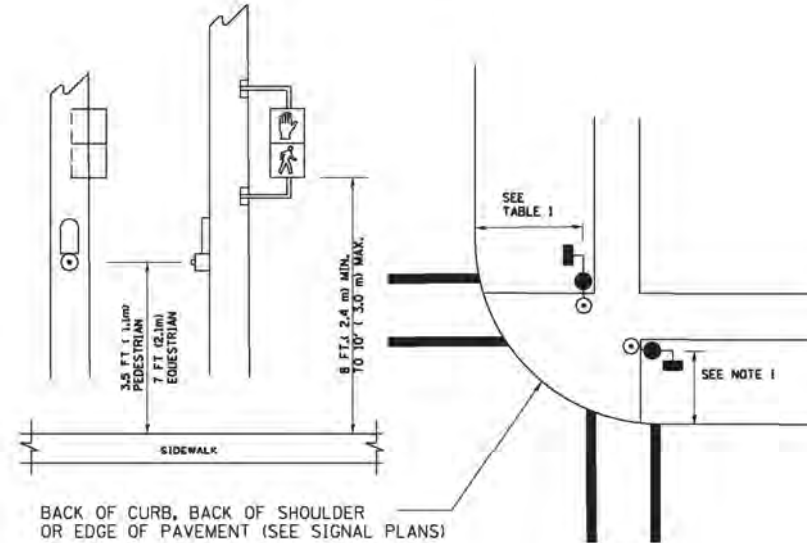

**NOTES:**

1. REFER TO THE TRAFFIC SIGNAL EQUIPMENT OFFSET TABLE.
2. PROVIDE A LEVEL ALL-WEATHER SURFACE (CONCRETE SIDEWALK, ASPHALT BICYCLE PATH SURFACE OR MATCHING MATERIAL TO THE ADJACENT SURFACE) UP TO THE PEDESTRIAN SIGNAL POST OR THE PEDESTRIAN PUSH BUTTON POST.
3. THE FACE OF THE PEDESTRIAN PUSHBUTTON SHALL BE PARALLEL TO THE CROSSWALK TO BE USED.
4. THE LOCATIONS AND INSTALLATION OF PEDESTRIAN SIGNAL HEADS AND PEDESTRIAN PUSHBUTTONS SHALL MEET THE REQUIREMENTS OF THE MUTCD AND INFORMATION FOUND IN THE "AMERICANS WITH DISABILITIES ACT ACCESSIBILITY GUIDELINES FOR BUILDINGS AND FACILITIES."

**RECOMMENDED PUSHBUTTON LOCATIONS**

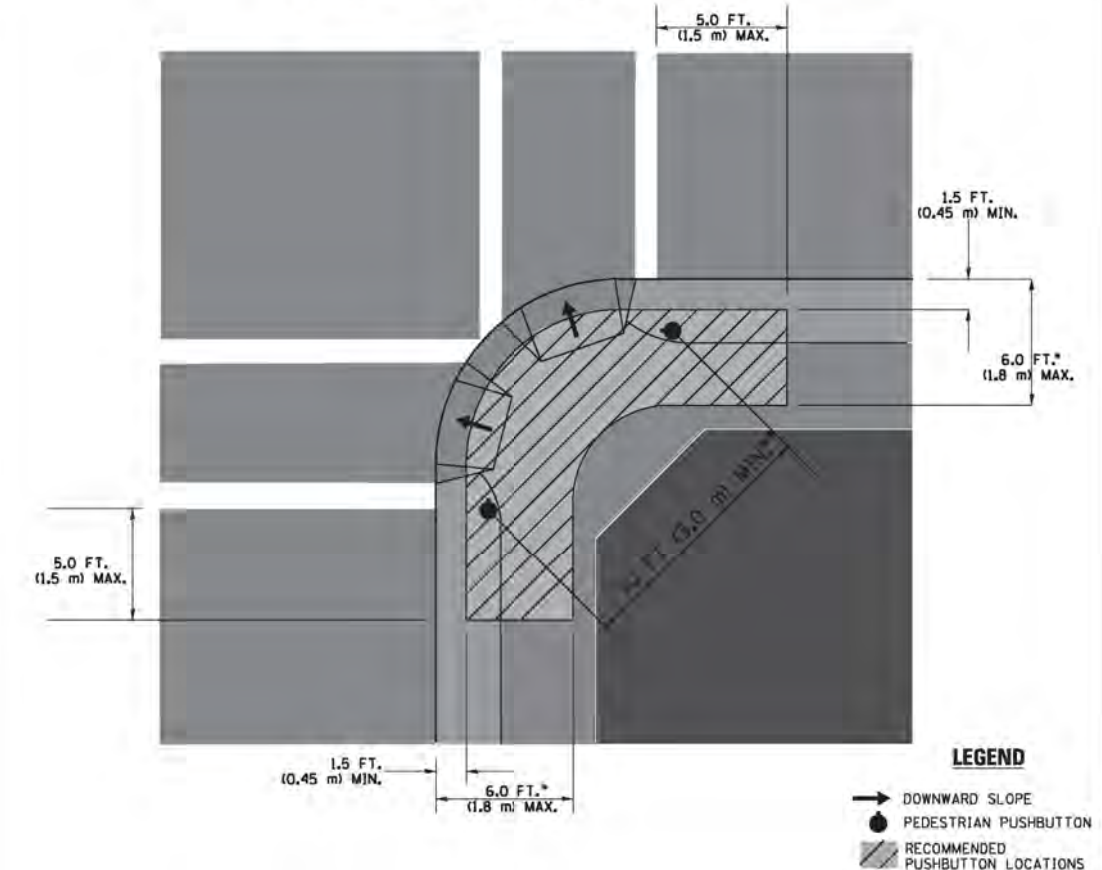

- WHERE THERE ARE CONSTRAINTS THAT MAKE IT IMPRACTICAL TO PLACE THE PEDESTRIAN PUSHBUTTON BETWEEN 1.5 FT (0.45 m) AND 6 FT (1.8 m) FROM THE EDGE OF THE CURB, SHOULDER, OR PAVEMENT, IT SHOULD NOT BE FURTHER THAN 10 FT (3 m) FROM THE EDGE OF CURB, SHOULDER, OR PAVEMENT.
- WHERE THERE ARE CONSTRAINTS ON A PARTICULAR CORNER THAT MAKE IT IMPRACTICAL TO PROVIDE THE 10 FT (3 m) SEPERATION BETWEEN THE TWO PEDESTRIAN PUSHBUTTONS, THE PUSHBUTTONS MAY BE PLACED CLOSER TOGETHER OR ON THE SAME POLE.

**NOTES:**

1. PEDESTRIAN SIGNAL HEADS SHALL BE MOUNTED WITH THE BOTTOM OF THE SIGNAL HOUSING INCLUDING BRACKETS NOT LESS THAN 8 FT (2.4 m) OR MORE THAN 10 FT (3 m) ABOVE SIDEWALK LEVEL, AND SHALL BE POSITIONED AND ADJUSTED TO PROVIDE MAXIMUM VISIBILITY AT THE BEGINNING OF THE CONTROLLED CROSSWALK.
2. THE BOTTOM OF THE SIGNAL HOUSING (INCLUDING BRACKETS) OF A VEHICULAR SIGNAL FACE THAT IS NOT LOCATED OVER A HIGHWAY SHALL BE AT LEAST 8 FT (2.4 m) BUT NOT MORE THAN 19 FT (5.8 m) ABOVE THE SIDEWALK OR, IF THERE IS NO SIDEWALK, ABOVE THE PAVEMENT GRADE AT THE CENTER OF THE ROADWAY.
3. THE BOTTOM OF THE SIGNAL HOUSING AND ANY RELATED ATTACHMENTS TO A SIGNAL FACE LOCATED OVER ANY PORTION OF A HIGHWAY SHALL BE ACCORDING TO CURRENT STATE STANDARDS 877001, 877002, 877006, 877011 AND 877012 WITH A MINIMUM OF 16 FT (5.0 m) AND A MAXIMUM OF 18 FT (5.5 m) FROM THE HIGHEST POINT OF PAVEMENT.
4. THE BOTTOM OF THE TEMPORARY SPAN WIRE MOUNTED SIGNAL HOUSING AND ANY RELATED ATTACHMENTS TO A SIGNAL FACE LOCATED OVER ANY PORTION OF A HIGHWAY SHALL BE ACCORDING TO CURRENT STATE STANDARD 880001 WITH A MINIMUM OF 17 FT (5.18 m) FROM THE HIGHEST POINT OF PAVEMENT.
5. THE TOP OF THE SIGNAL HOUSING OF A SIGNAL FACE LOCATED OVER ANY PORTION OF A HIGHWAY SHALL NOT BE MORE THAN 25.6 FT (7.8 m) ABOVE THE PAVEMENT.

**TRAFFIC SIGNAL EQUIPMENT OFFSET**

TRAFFIC SIGNAL EQUIPMENT	COMBINATION CONCRETE CURB AND GUTTER (MINIMUM DISTANCE FROM BACK OF CURB TO CENTERLINE OF FOUNDATION)	SHOULDER/NON-CURBED AREA (MINIMUM DISTANCE FROM EDGE OF PAVEMENT TO CENTERLINE OF FOUNDATION)
TRAFFIC SIGNAL MAST ARM POLE	6 FT (1.8m)	SHOULDER WIDTH + 2 FT (0.6m), MINIMUM 10 FT (3.0m)
TRAFFIC SIGNAL POST	4 FT (1.2m)	SHOULDER WIDTH + 2 FT (0.6m), MINIMUM 10 FT (3.0m)
PEDESTRIAN SIGNAL POST	4 FT (1.2m)	SHOULDER WIDTH + 2 FT (0.6m), MINIMUM 10 FT (3.0m)
PEDESTRIAN PUSHBUTTON POST	4 FT (1.2m)	SHOULDER WIDTH + 2 FT (0.6m), MINIMUM 10 FT (3.0m)
TEMPORARY WOOD POLE	6 FT (1.8m)	SHOULDER WIDTH + 2 FT (0.6m), MINIMUM 10 FT (3.0m)
CONTROLLER CABINET	6 FT (1.8m) MINIMUM DISTANCE SEE NOTE 2	SHOULDER WIDTH + 6 FT (1.8m), MINIMUM 16 FT (4.9m) SEE NOTE 3.
SERVICE INSTALLATION, GROUND MOUNT	6 FT (1.8m) MINIMUM DISTANCE SEE NOTE 2	SHOULDER WIDTH + 6 FT (1.8m), MINIMUM 16 FT (4.9m) SEE NOTE 3.

**NOTES:**

1. CONTACT THE "AREA TRAFFIC SIGNAL MAINTENANCE AND OPERATIONS ENGINEER" FOR ASSISTANCE IN LOCATING THE TRAFFIC SIGNAL EQUIPMENT WHEN THERE ARE CONFLICTS WITH DITCHES OR THE MINIMUM OFFSET DISTANCES CANNOT BE MET.
2. MINIMUM DISTANCE FROM THE BACK OF CURB TO THE ROADWAY SIDE OF THE FOUNDATION.
3. MINIMUM DISTANCE FROM THE EDGE OF PAVEMENT TO THE ROADWAY SIDE OF THE FOUNDATION.
4. ANY CHANGES TO THE OFFSETS OF THE FOUNDATIONS, FROM THE MINIMUM DISTANCES LISTED IN THE "TRAFFIC SIGNAL EQUIPMENT OFFSET" CHART AND THE TRAFFIC SIGNAL INSTALLATION PLAN, COULD EFFECT THE PLACEMENT OF THE SIGNAL HEADS, PEDESTRIAN SIGNAL HEADS AND THE PEDESTRIAN PUSHBUTTONS. THE SIGNAL HEAD PLACEMENT ON THE MAST ARMS SHALL REMAIN AS PER THE TRAFFIC SIGNAL INSTALLATION PLAN AND THE "TRAFFIC SIGNAL MAST ARM AND SIGNAL POST" DETAIL ABOVE. THE PROPOSED MAST ARM LENGTHS MAY NEED TO BE REVISED TO MEET THE ABOVE REQUIREMENTS. THE PEDESTRIAN SIGNAL HEADS AND PEDESTRIAN PUSHBUTTONS MUST MEET THE REQUIREMENTS UNDER THE DETAILS ON THIS SHEET.

TS SHT NO. 3

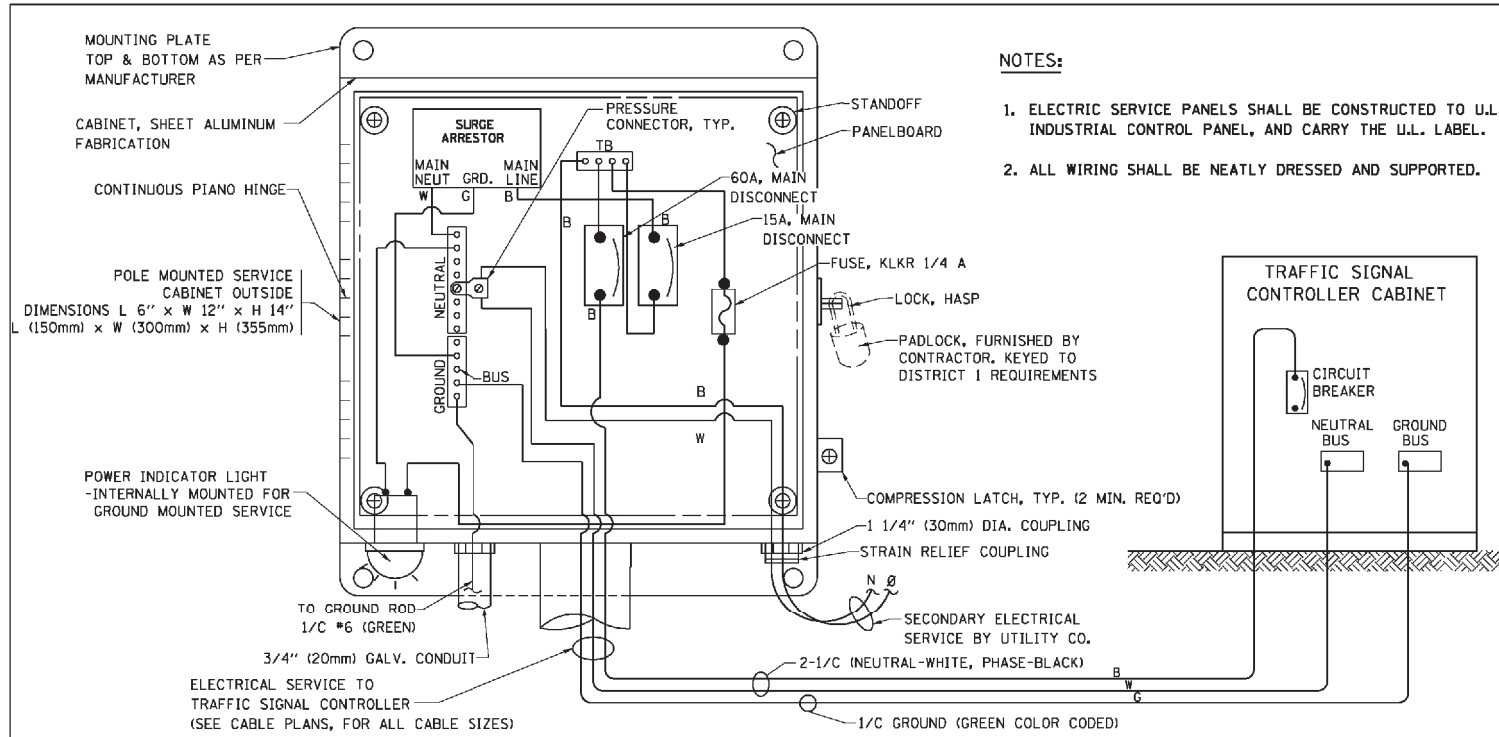

**ELECTRICAL SERVICE – PANEL DIAGRAM (TYPICAL FOR POLE AND GROUND MOUNTED SERVICE)  
SERVICE INSTALLATION POLE MOUNT (SHOWN)  
(NOT TO SCALE)**

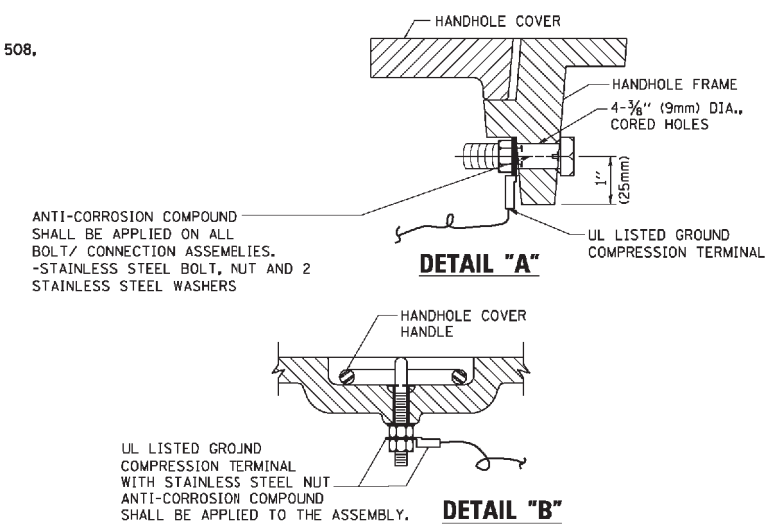

**NOTES:  
GROUNDING SYSTEM**

- THE GROUNDING SYSTEM SHALL CONSIST OF AN INSULATED CONDUCTOR TYPE XLP, NO. 6 A.W.G., STRANDED COPPER TO BE INSTALLED IN RACEWAYS. THE GROUNDING CABLE SHALL BE INSTALLED IN A CONTINUOUS MANNER AS SHOWN ON THE CABLE PLAN PROVIDED. ALL GROUNDING CONDUCTORS SHALL BE BONDED TO METAL ENCLOSURE (HANDHOLE, POST, MAST ARM, CONTROLLER, ETC.). GROUND ROD SHALL BE 3/4" DIA. x 10'-0" (20mm x 3.0m) LONG, COPPER CLAD. ONE GROUND ROD SHALL BE INSTALLED AT ALL POST FOUNDATIONS, POLE FOUNDATIONS, CONTROLLER CABINET FOUNDATION AND ELECTRICAL SERVICE INSTALLATION AS INDICATED ON THE CABLE PLAN. IF THERE ARE ANY SPECIAL CONDITIONS SUCH AS SUB-SURFACE CONDITIONS OR INSTALLATION PROBLEMS, THE RESIDENT ENGINEER SHALL BE NOTIFIED OR CONTACT THE BUREAU OF TRAFFIC, ILLINOIS DEPARTMENT OF TRANSPORTATION DISTRICT ONE AT (847) 705-4139.
- THE NEUTRAL CONDUCTOR AND THE GROUND CONDUCTOR SHALL BE CONNECTED IN THE SERVICE INSTALLATION. AT NO OTHER POINT IN THE TRAFFIC SIGNAL SYSTEM SHALL THE NEUTRAL AND GROUND CONDUCTORS BE CONNECTED.
- ALL EQUIPMENT GROUNDING CONDUCTORS SHALL TERMINATE AT THE GROUND BUS IN THE CONTROLLER CABINET.
- THE CONTRACTOR SHALL PROVIDE A GROUND CABLE WITH CONNECTORS BETWEEN THE HANDHOLE COVER AND HANDHOLE FRAME.

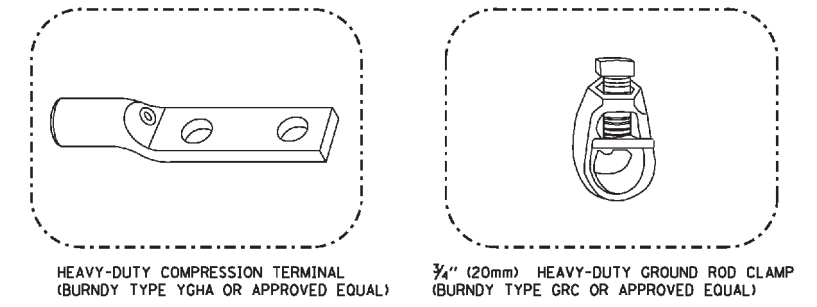
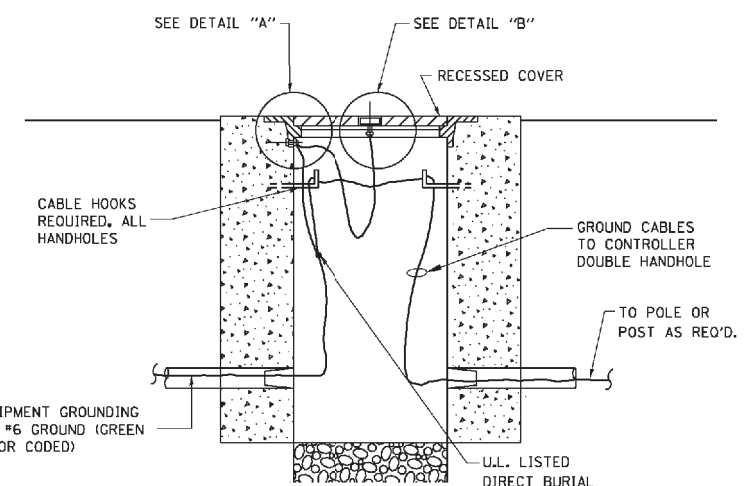

- NOTES:**
- ALL CLAMPS SHALL BE BRONZE OR COPPER, UL APPROVED.
  - GROUND CABLE SHALL BE LOOPED OVER HOOKS IN THE HANDHOLES 6.5' (2.0m) SLACK SHALL BE PROVIDED IN SINGLE HANDHOLES 13' (4.0m) OF SLACK SHALL BE PROVIDED IN DOUBLE HANDHOLES. 5' (1.4m) OF SLACK SHALL BE PROVIDED BETWEEN FRAME AND COVER.

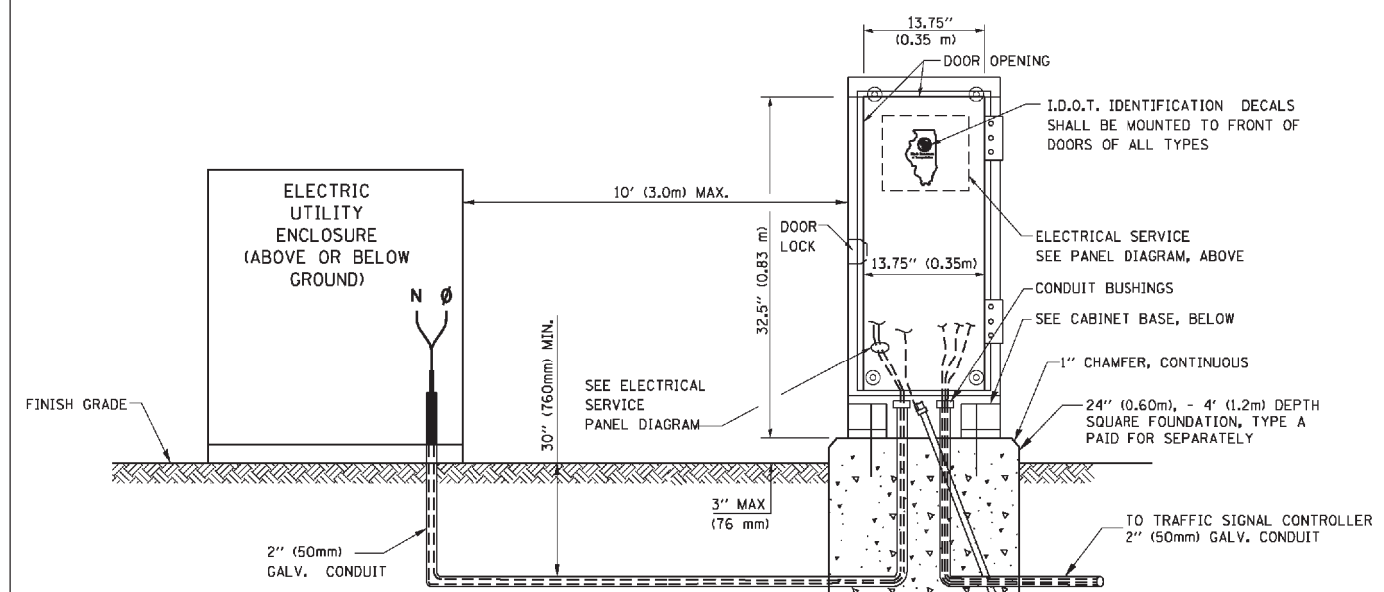
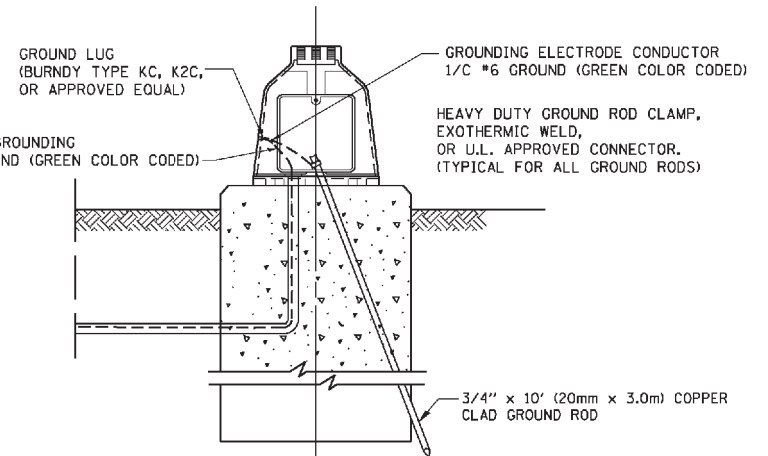
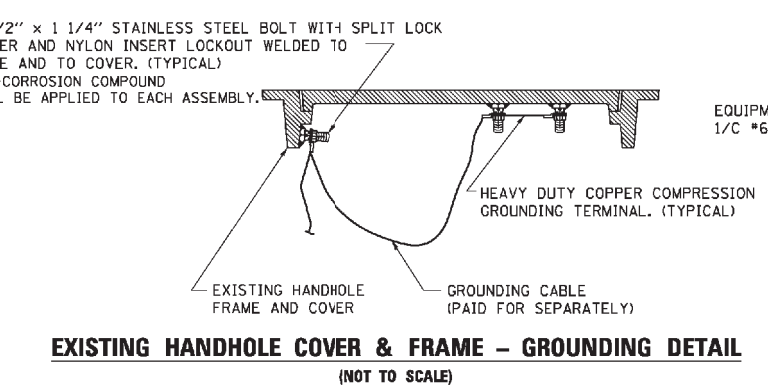

**SERVICE INSTALLATION GROUND MOUNT  
(NOT TO SCALE)**

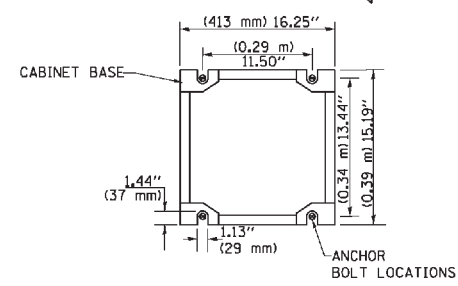

**CABINET – BASE BOLT PATTERN  
(NOT TO SCALE)**

TS SHT NO. 4

FILE NAME =	USER NAME = faotemj	DESIGNED - DAD	REVISED - DAG 1-1-14	<b>STATE OF ILLINOIS DEPARTMENT OF TRANSPORTATION</b>	<b>DISTRICT ONE STANDARD TRAFFIC SIGNAL DESIGN DETAILS</b>			F.A.U. RTE. 2503	SECTION 16-00313-00-MS	COUNTY KANE	TOTAL SHEETS 254	SHEET NO. 111
DRAWN - BCK	CHECKED - DAD	DATE - 10-28-09	REVISED -		SCALE: NONE	SHEET NO. 4 OF 7 SHEETS	STA. TO STA.	<b>TS-05</b>		CONTRACT NO.		
PLOT SCALE = 5/8" = 1' / in.	PLOT DATE = 1/13/2014	DATE - 10-28-09	REVISED -		FED. ROAD DIST. NO. 1 ILLINOIS FED. AID PROJECT							

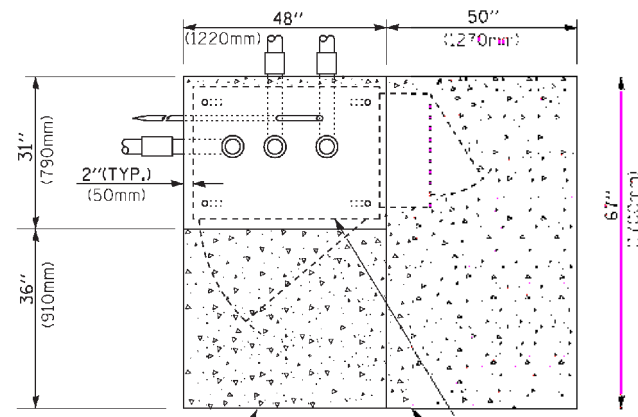

**TOP VIEW**

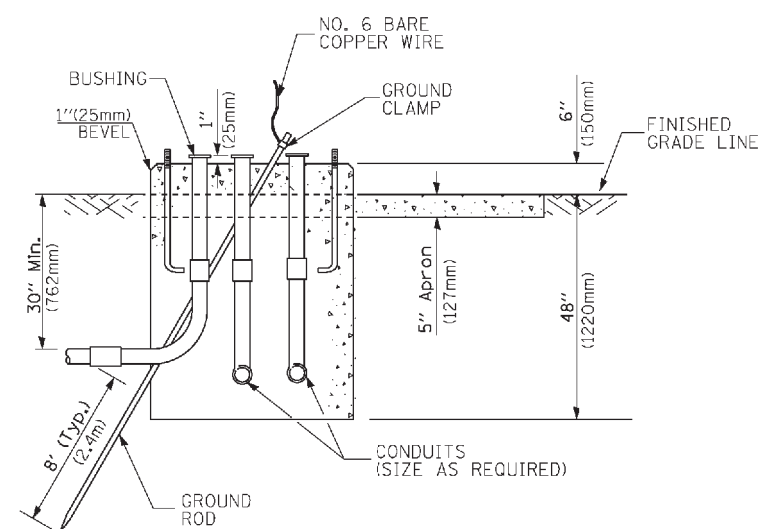

**TYPE D  
FOR GROUND MOUNTED  
CONTROLLER CABINET  
AND UPS BATTERY CABINET**

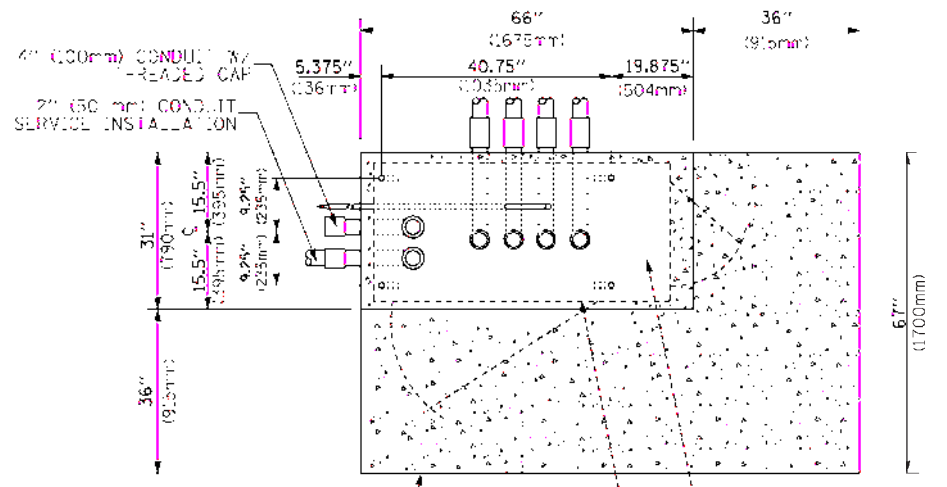

**TOP VIEW**

**NOTE:**  
TOP OF FOUNDATION SHALL BE HIGHER THAN TOP OF DOUBLE HANDHOLE

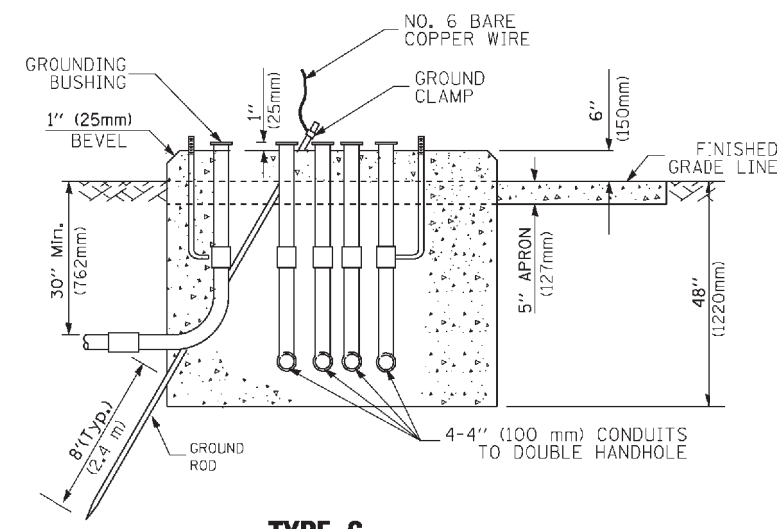

**TYPE C  
FOR GROUND MOUNTED  
SUPER P (TYPE IV) AND SUPER R (TYPE V)  
CONTROLLER CABINETS**

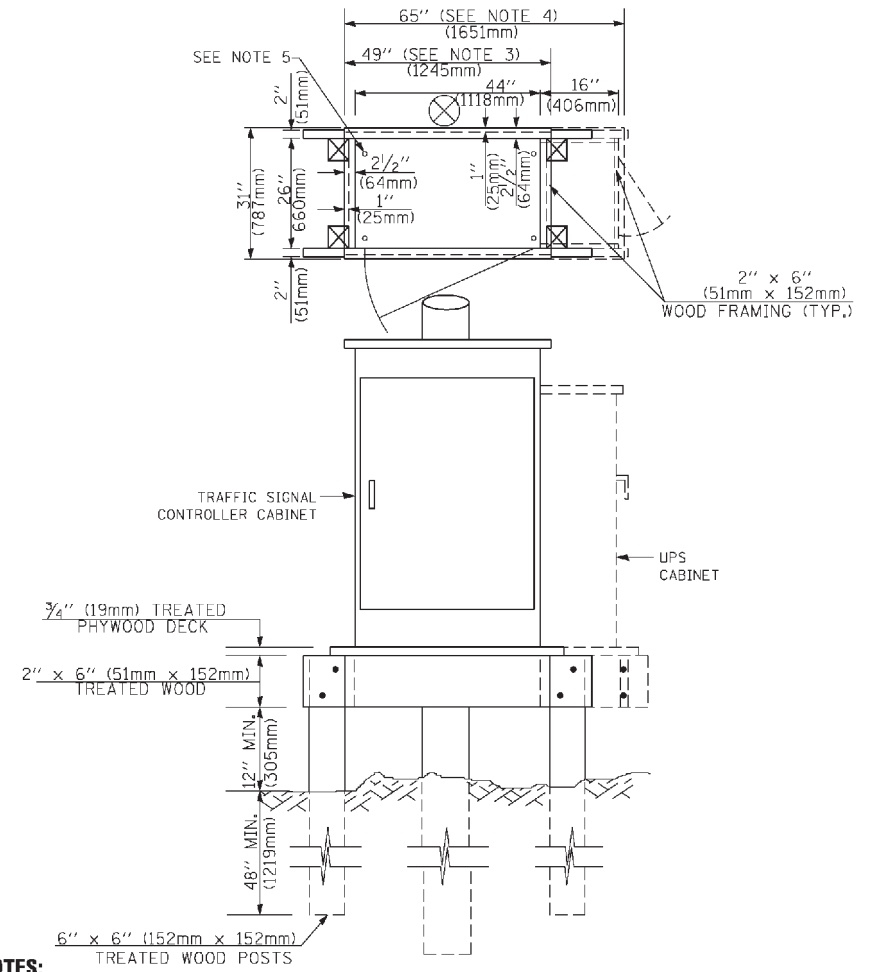

**NOTES:**

- BASED ON CONTROLLER CABINET TYPE IV WITH BASE DIMENSIONS OF 26" x 44" (660mm x 1118mm). ADJUST PLATFORM SIZE TO FIT CABINET BASE DIMENSIONS BEING SUPPLIED.
- BASED ON UNINTERRUPTIBLE POWER SUPPLY CABINET WITH BASE DIMENSIONS OF 16" x 25" (406mm x 635mm). ADJUST PLATFORM SIZE TO FIT CABINET BASE DIMENSIONS BEING SUPPLIED.
- PLATFORM SIZE FOR CONTROLLER CABINET TYPE IV.
- PLATFORM SIZE FOR CONTROLLER CABINET TYPE IV AND UNINTERRUPTIBLE POWER SUPPLY CABINET.
- DRILLED HOLES THROUGH THE PLATFORM BASE TO MATCH THE CONTROLLER CABINET BOLT TEMPLATE. FASTEN THE CONTROLLER CABINET TO THE PLATFORM WITH CARRIAGE BOLTS, WASHERS AND NUTS.
- FASTEN ALL SUPPORT WOOD FRAMING TO THE WOOD POSTS WITH 2 LAG SCREWS FOR EACH CONNECTION.

**TEMPORARY SIGNAL CONTROLLER  
WOOD SUPPORT PLATFORM**

CABLE SLACK LENGTH	FEET	METER
HANDHOLE	6.5	2.0
DOUBLE HANDHOLE	13.0	4.0
SIGNAL POST	2.0	0.6
MAST ARM	2.0	0.6
CONTROLLER CABINET	1.5	0.5
FIBER OPTIC AT CABINET	13.0	4.0
ELECTRIC SERVICE AT (CABINET OR SERVICE LOCATION)	1.5	0.5
GROUND CABLE (SIGNAL POST, MAST ARM, CABINET)	1.5	0.5
GROUND CABLE (BETWEEN FRAME AND COVER)	5.0	1.6

**CABLE SLACK**

VERTICAL CABLE LENGTH	FEET	METER
MAST ARM POLE (MAST ARM MOUNTED SIGNAL HEAD) (L = MAST ARM LENGTH - DISTANCE TO SIGNAL HEAD FROM END OF ARM)	20.0+L	6.0+L
BRACKET MOUNTED (MAST ARM POLE OR SIGNAL POLE)	13.0	4.0
PEDESTRIAN PUSH BUTTON	6.0	2.0
SERVICE INSTALLATION POLE MOUNT TO SERVICE DROP	13.5	4.1
SERVICE INSTALLATION POLE MOUNT TO GROUND	13.5	4.1
SERVICE INSTALLATION GROUND MOUNT	6.0	2.0
FOUNDATION (SIGNAL POST, MAST ARM POLE, CONTROLLER CABINET, SERVICE-GROUND MOUNT)	3.0	1.0

**VERTICAL CABLE LENGTH**

FOUNDATION	DEPTH
TYPE A - Signal Post	4'-0" (1.2m)
TYPE C - CONTROLLER W/ UPS	4'-0" (1.2m)
TYPE D - CONTROLLER	4'-0" (1.2m)
SERVICE INSTALLATION, GROUND MOUNT, TYPE A - SQUARE	4'-0" (1.2m)

**DEPTH OF FOUNDATION**

MAST ARM LENGTH	Foundation Depth	Foundation Diameter	Spiral Diameter	Quantity of Rebars	Size of Rebars
Less than 30' (9.1 m)	10'-0" (3.0 m)	30" (750mm)	24" (600mm)	8	6(19)
Greater than or equal to 30' (9.1 m) and less than 40' (12.2 m)	13'-6" (4.1 m)	30" (750mm)	24" (600mm)	8	6(19)
	11'-0" (3.4 m)	36" (900mm)	30" (750mm)	12	7(22)
Greater than or equal to 40' (12.2 m) and less than 50' (15.2 m)	13'-0" (4.0 m)	36" (900mm)	30" (750mm)	12	7(22)
	15'-0" (4.6 m)	36" (900mm)	30" (750mm)	12	7(22)
Greater than or equal to 50' (15.2 m) and less than 65' (19.8 m)	21'-0" (6.4 m)	42" (1060mm)	36" (900mm)	16	8(25)
	25'-0" (7.6 m)	42" (1060mm)	36" (900mm)	16	8(25)

**NOTES:**

- These foundation depths are for sites which have cohesive soils (clayey silt, sandy clay, etc.) along the length of the shaft, with an average Unconfined Compressive Strength (qu) > 1.0 tsf (100 kpa). This strength shall be verified by boring data prior to construction or with testing by the Engineer during foundation drilling. The Bureau of Bridges & Structures should be contacted for a revised design if other conditions are encountered.
- Combination mast arm assemblies under 55 feet (16.8 m) shall use 36" (900 mm) diameter foundations.
- Combination mast arm assemblies under 56 feet (16.8 m) through 75 feet (22.9 m) shall use 42" (1060 mm) diameter foundations.
- For mast arm assemblies with dual arms refer to state standard 878001..

**DEPTH OF MAST ARM FOUNDATIONS, TYPE E**

TS SHT NO. 5

FILE NAME =	USER NAME = footemj	DESIGNED - DAG	REVISED - DAG 1-1-14	<b>STATE OF ILLINOIS DEPARTMENT OF TRANSPORTATION</b>	<b>DISTRICT ONE STANDARD TRAFFIC SIGNAL DESIGN DETAILS</b>	F.A.U. RTE.	SECTION	COUNTY	TOTAL SHEETS	SHEET NO.
c:\pwwork\pwwork\footemj\d0188315\ts05.dgn	DRAWN - BCK	REVISED -	2503			16-00313-00-MS	KANE	254	112	
PLOT SCALE = 5/8"=1'-0"	CHECKED - DAD	REVISED -	<b>TS-05</b>			CONTRACT NO.				
PLOT DATE = 1/13/2014	DATE - 10-28-09	REVISED -	FED. ROAD DIST. NO. 1 ILLINOIS FED. AID PROJECT							

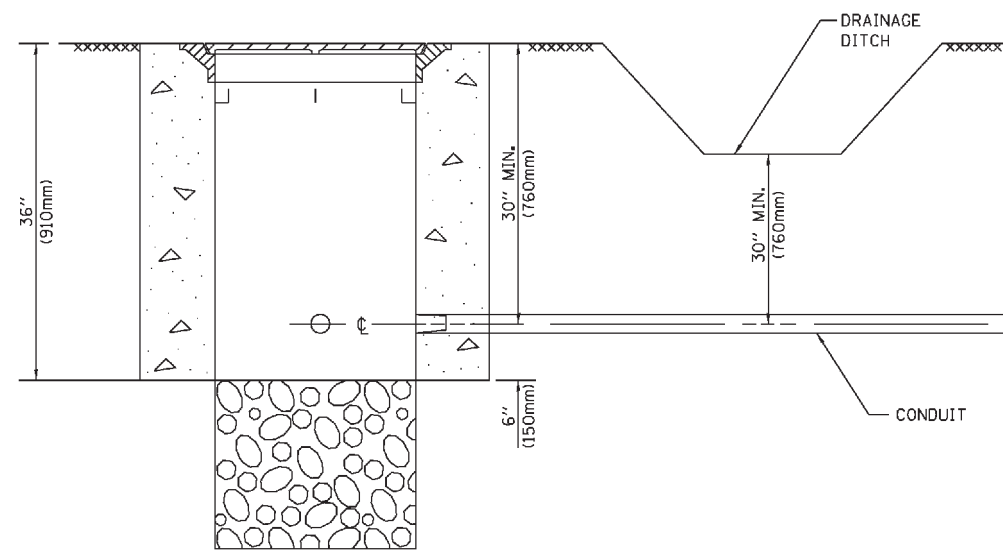

**NOTES:**

1. CONDUIT DEPTH SHALL BE A MINIMUM OF 30" (760mm) BELOW THE BOTTOM OF THE DRAINAGE DITCH OR ANY SLOPING GROUND
2. THE MINIMUM CONDUIT DEPTH APPLIES TO ALL CONDUIT PLACED UNDER ROADWAY PAVEMENT, MULTI-USE PATHS, SIDEWALKS AND SOIL SURFACES.
3. THE MINIMUM CONDUIT DEPTH APPLIES TO ALL HANDHOLES, HEAVY DUTY HANDHOLES AND DOUBLE HANDHOLES.

**HANDHOLE WITH MINIMUM CONDUIT DEPTH**  
(NOT TO SCALE)

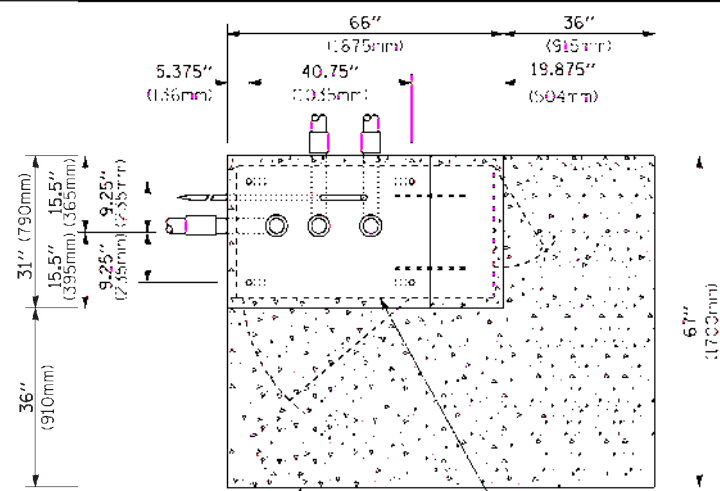

**TOP VIEW**  
(NOT TO SCALE)

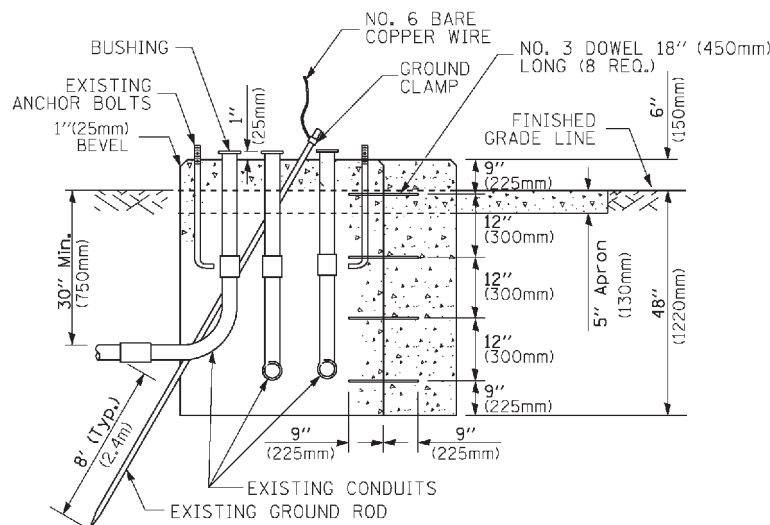

**MODIFY EXISTING TYPE "D" FOUNDATION TO TYPE "C" FOUNDATION**  
(NOT TO SCALE)

ITEM NO.	IDENTIFICATION
1	OUTLET BOX- GALV. 21 CU. IN. (0.000344 CU-M)
2	LAMP HOLDER AND COVER
3	OUTLET BOX COVER
4	RUBBER COVER GASKET
5	REDUCING BUSHING
6	3/4" (19 mm) CLOSE NIPPLE
7	3/4" (19 mm) LOCKNUT
8	3/4" (19 mm) HOLE PLUG
9	SADDLE BRACKET - GALV.
10	6 WATT PAR 38 LED FLOOD LAMP
11	DETECTOR UNIT
12	POST CAP [18 FT. (5.4 m) POST MIN.]

**NOTES:**

1. ALL ELECTRICAL ITEMS, EXCEPT ITEMS #2 AND #11 SHALL BE ALUMINUM OR GALVANIZED
2. ITEM #1- OZ/GEDNEY FSX-1-50 OR EQUIVALENT  
ITEM #2- MULBERRY CON-O-SHADE LAMP SHIELD OR EQUIVALENT  
ITEM #9- "BAND-IT" SADDLE BRACKET OR EQUIVALENT
3. WHEN POST MOUNTING IS SPECIFIED, ITEM #9 SHALL NOT BE REQUIRED. THE DETECTION UNIT SHALL BE MOUNTED DIRECTLY ON TOP OF THE CAP BY DRILLING AND TAPPING A 3/4" (19 mm) HOLE WITH PIPE THREADS. THE POST CAP SHALL EITHER BE SCREWED TO THE TOP OF THE POST OR A MINIMUM OF 3 TIGHTENING SCREWS SHALL BE REQUIRED ON EACH CAP.

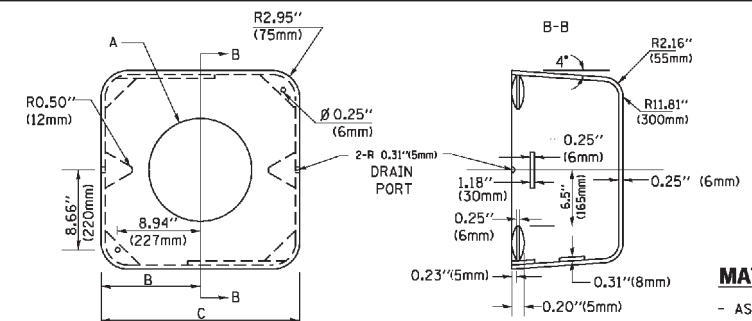

**MATERIAL:**  
- ASTM A36 STEEL  
- ASTM A-123 HOT DIPPED GALVANIZED

A	B	C	HEIGHT	WEIGHT
VARIABLES	9.5" (241mm)	19" (483mm)	7" (178mm) - 12" (300mm)	53 lbs (24kg)
VARIABLES	10.75" (273mm)	21.5" (546mm)	7" (178mm) - 12" (300mm)	68 lbs (31 kg)
VARIABLES	13.0" (330mm)	26" (660mm)	7" (178mm) - 12" (300mm)	81 lbs (37 kg)
VARIABLES	18.5" (470mm)	37" (940mm)	7" (178mm) - 12" (300mm)	126 lbs (57 kg)

**SHROUD**

**NOTES:**

1. DIMENSION "A" IS EQUAL TO THE DIAMETER OF THE MAST ARM POLE AT THE TOP OF THE SHROUD. THE SHROUD SHALL BE TIGHT TO THE MAST ARM POLE.
2. THE SUPPLIER SHALL VERIFY THE ABOVE DIMENSIONS BASED ON MAST ARM REQUIREMENTS.
3. THE HEIGHT OF THE SHROUD SHALL COVER THE ANCHOR BOLTS, NUTS AND MAST ARM POLE BASE.

**NOTE:**

SUPPORT EXISTING CABINET AND CONTROL EQUIPMENT ABOVE FOUNDATION TO KEEP TRAFFIC SIGNAL FUNCTIONING WHILE FOUNDATION MODIFICATION WORK IS PROCEEDING.

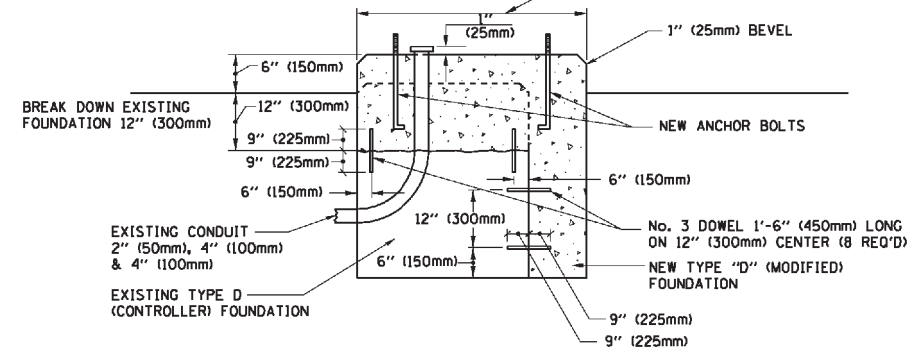

**MODIFY EXISTING TYPE "D" FOUNDATION**

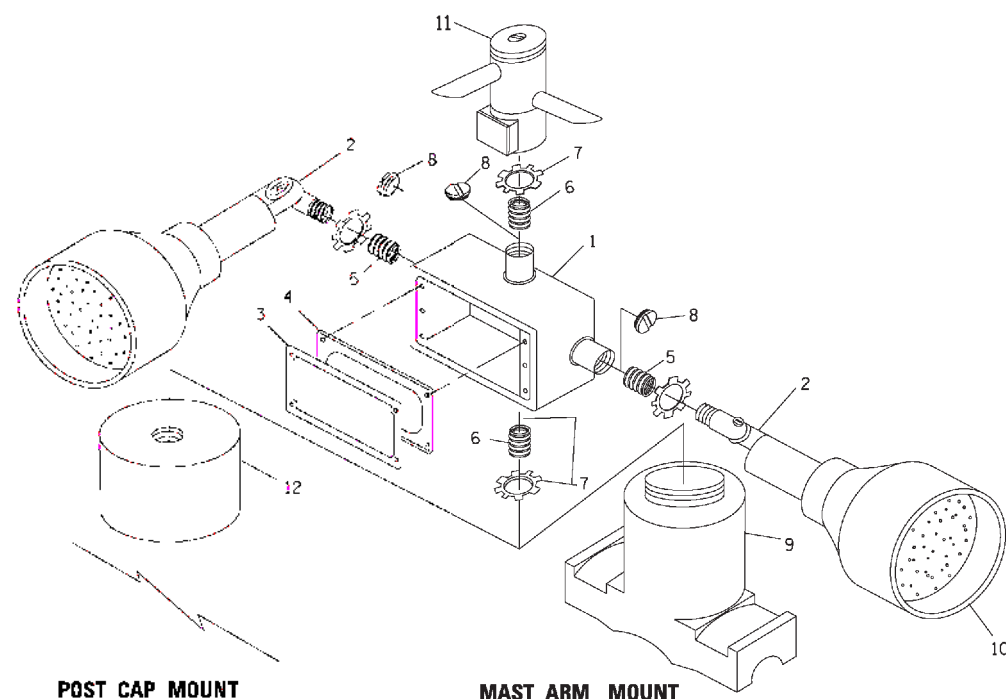

**POST CAP MOUNT**      **MAST ARM MOUNT**  
**EMERGENCY VEHICLE DETECTOR WITH CONFIRMATION BEACON MOUNTING DETAIL**

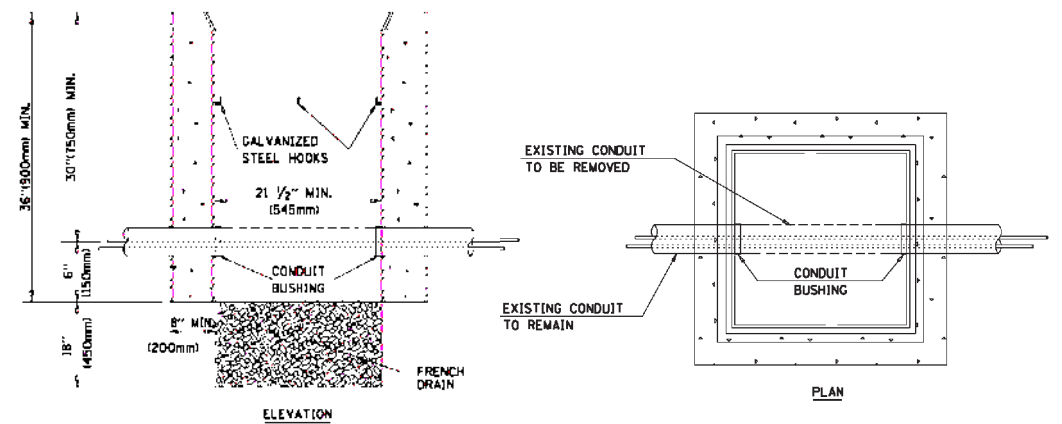

**NOTES:**

1. HANDHOLE CONSTRUCTED PER STATE STANDARD 814001.
2. REMOVAL OF THE EXISTING CONDUIT FROM THE HANDHOLE AND THE INSTALLATION OF THE CONDUIT BUSHINGS SHALL BE INCLUDED WITH THE COST OF THE HANDHOLE.

**HANDHOLE TO INTERCEPT EXISTING CONDUIT**

TS SHT NO. 6

FILE NAME =	USER NAME = faotemj	DESIGNED - DAD	REVISED - DAG 1-1-14
ca:\pwwork\pwwork\faotemj\d0188315\ts05.dgn		DRAWN - BCK	REVISED -
		CHECKED - DAD	REVISED -
		DATE - 10-28-09	REVISED -

**STATE OF ILLINOIS**  
**DEPARTMENT OF TRANSPORTATION**

**DISTRICT ONE**  
**STANDARD TRAFFIC SIGNAL DESIGN DETAILS**

SCALE: NONE      SHEET NO. 6 OF 7 SHEETS      STA.      TO STA.

F.A.U. RTE. 2503	SECTION 16-00313-00-MS	COUNTY KANE	TOTAL SHEETS 254	SHEET NO. 113
TS-05		CONTRACT NO.		
FED. ROAD DIST. NO. 1 ILLINOIS FED. AID PROJECT				

**SIGN TABLE**

SIGN	DIMENSIONS
R10-3b	9" (228mm) X 12" (305mm)
R10-3d	9" (228mm) X 12" (305mm)
R10-3e	9" (228mm) X 15" (381mm)

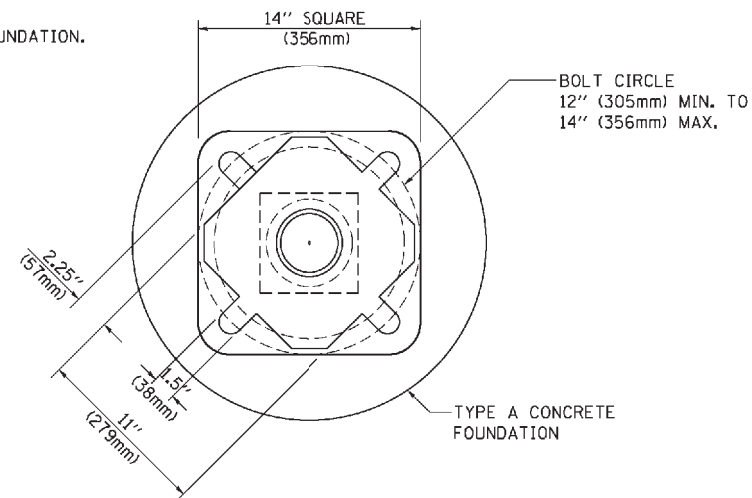
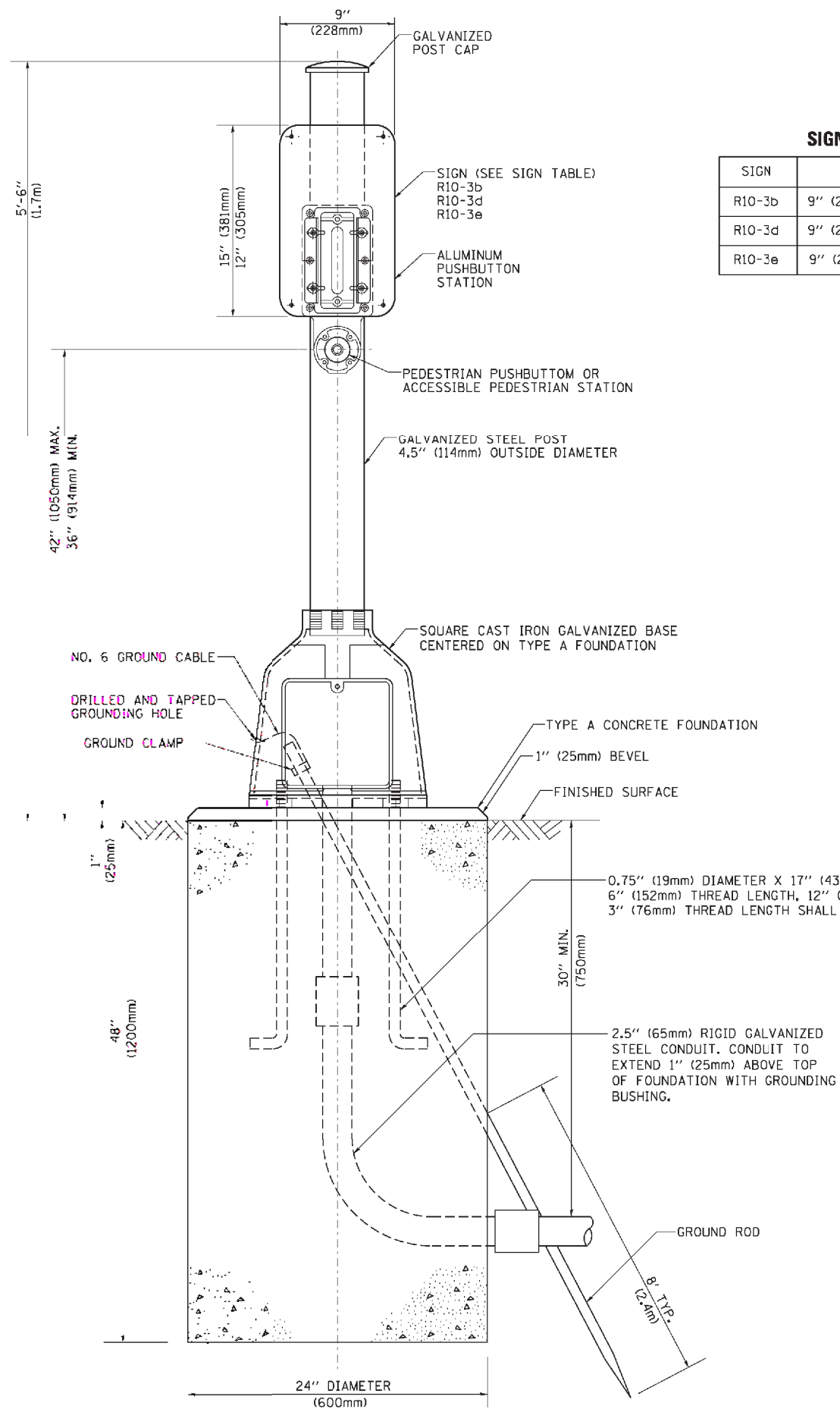

**BOLT PATTERN**

**PEDESTRIAN PUSH BUTTON POST, TYPE A**

TS SHT NO. 7

FILE NAME =	USER NAME = faotemj	DESIGNED - DAG	REVISED - DAG 1-1-14	<b>STATE OF ILLINOIS DEPARTMENT OF TRANSPORTATION</b>	<b>DISTRICT ONE STANDARD TRAFFIC SIGNAL DESIGN DETAILS</b>	F.A.U. RTE.	SECTION	COUNTY	TOTAL SHEETS	SHEET NO.
c:\pwworksp\pwworksp\faotemj\d0188315\ts05.dgn	DRAWN - GND	REVISED -	REVISED -			2503	16-00313-00-MS	KANE	254	114
PLOT SCALE = 50.0000' / in.	CHECKED - DAD	REVISED -	REVISED -			<b>TS-05</b>		CONTRACT NO.		
PLOT DATE = 1/13/2014	DATE - 10/1/2012	REVISED -	REVISED -			SCALE: NONE		SHEET NO. 7 OF 7 SHEETS		STA. TO STA.
						FED. ROAD DIST. NO. 1 ILLINOIS FED. AID PROJECT				

**SIGN PANEL – TYPE 1 OR TYPE 2**

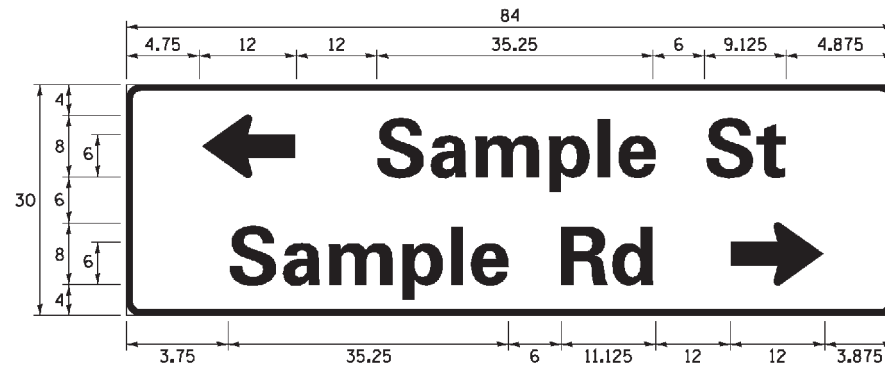
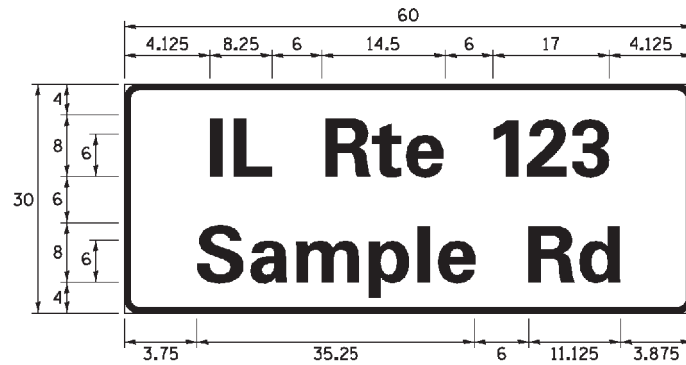
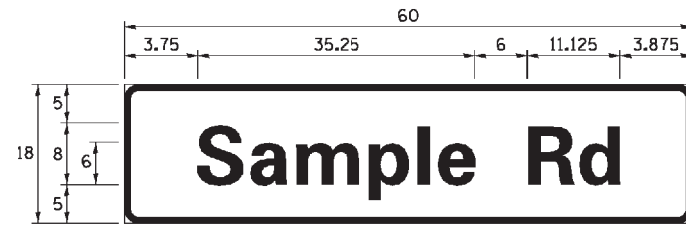

DESIGN SERIES	AREA (SQ FT)	SIGN PANEL TYPE	SHEETING TYPE	QTY. REQUIRED
D OR C	-	1 OR 2	ZZ	-

ALL DIMENSIONS ARE IN INCHES EXCEPT NOTED OTHERWISE

**COMMON STREET NAME ABBREVIATIONS AND WIDTHS**

NAME	ABBREVIATION	WIDTH (INCH)	
		SERIES "C"	SERIES "D"
AVENUE	Ave	15.000	18.250
BOULEVARD	Blvd	17.125	20.000
CIRCLE	Cir	11.125	13.000
COURT	Ct	8.250	9.625
DRIVE	Dr	8.625	10.125
HIGHWAY	Hwy	18.375	22.000
ILLINOIS	IL	7.000	8.250
LANE	Ln	9.125	10.750
PARKWAY	Pkwy	23.375	27.375
PLACE	Pl	7.125	7.750
ROAD	Rd	9.625	11.125
ROUTE	Rte	12.625	14.500
STREET	St	8.000	9.125
TERRACE	Ter	12.625	14.625
TRAIL	Tr	7.750	9.125
UNITED STATES	US	10.375	12.250

**GENERAL NOTES**

- WHERE MAST ARM MOUNTED STREET NAME SIGNS ARE SPECIFIED, THE MAST ARM ASSEMBLY AND POLES SHALL BE DESIGNED TO SUPPORT THE LOADINGS CALLED FOR ON STANDARDS 877001, 877002, 877006, 877011 AND 877012, AS APPLICABLE, PLUS TWO (2) SIGN PANELS 2'-6" x 8'-0" MOUNTED AS SHOWN. THE DESIGN SHALL BE IN ACCORDANCE WITH THE REQUIREMENTS OF THE CURRENT "STANDARD SPECIFICATIONS FOR STRUCTURAL SUPPORTS FOR HIGHWAY SIGNS, LUMINAIRES, AND TRAFFIC SIGNALS" AS PUBLISHED BY THE AMERICAN ASSOCIATION OF STATE HIGHWAY AND TRANSPORTATION OFFICIALS FOR 80 M.P.H. WIND VELOCITY.
- ALL SIGNS SHALL CONSIST OF A WHITE LEGEND AND BORDER (TYPE ZZ SHEETING) ON A GREEN BACKGROUND (TYPE ZZ SHEETING)
- THE SIGN LENGTH SHALL BE IN 6-INCH INCREMENTS, BUT THE OVERALL LENGTH SHALL NOT EXCEED 8'-0". ALL BORDERS SHALL BE 3/4" WIDE. CORNER RADIUS SHALL BE 1-7/8". THE SPACING BETWEEN THE WORDS SHOULD BE 6", IF POSSIBLE, BUT MAY BE REDUCED TO 5" WHEN SPACING IS CRITICAL. A MINIMUM OF 2-1/2" SHALL BE INCLUDED BETWEEN THE WORD AND THE RIGHT AND LEFT EDGES OF THE SIGN.
- A PREFERRED METHOD FOR THE SIGN DESIGN IS TO USE SERIES "D" LETTER ON A ONE-LINE SIGN 18" IN HEIGHT AND A MAXIMUM OF 8'-0" IN WIDTH. IF SERIES "D" DOES NOT FIT ON A 8'-0" SIGN, THEN SERIES "C" SHOULD BE TRIED. IF SERIES "C" DOES NOT FIT ON A 8'-0" SIGN, A 30" HIGH TWO-LINE SIGN CAN BE USED. THE CROSSROAD DESIGNATION AS TO STREET, AVENUE, ETC. SHOULD BE SPELLED OUT ON THE SECOND LINE, IF THE ABBREVIATION CANNOT FIT ON THE FIRST LINE.
- LED ILLUMINATED STREET NAME SIGNS CAN BE USED IN PLACE OF REGULAR SIGN PANELS BUT ANY SPECIAL WORDING AND SYMBOLOGY MUST BE APPROVED BY THE DEPARTMENT. GENERAL DESIGN REQUIREMENT AS LISTED ABOVE (COLOR, FONT, SIZE, ETC.) MUST BE FOLLOWED.
- SIGNFIX ALUMINUM CHANNEL FRAMING SYSTEM SHALL BE USED FOR ALL SIGNS ATTACHED TO SIGNAL POLES AND POSTS.

**LOCAL SUPPLIERS:**

- J.O. HERBERT COMPANY, INC  
MIDLOTHIAN, VA
- WESTERN REMAC, INC.  
WOODRIDGE, IL

**PARTS LISTING:**

- SIGN CHANNEL PART \*HPN053 (MED. CHANNEL)  
1/4" x 14 x 1" H.W.H. #3  
SELF TAPPING WITH NEOPRENE WASHER
- SIGN SCREWS PART \*HPN034 (UNIVERSAL)  
CHANNEL CLAMPS WITH STAINLESS STEEL STRAPPING
- BRACKETS

OTHER BRANDS OF MOUNTING HARDWARE ARE ACCEPTABLE, BASED UPON THE DEPARTMENT'S APPROVAL AND COMPATIBILITY WITH THE CHANNEL/BACKET OF THE ABOVE PRODUCT.

**MOUNTING LOCATION**

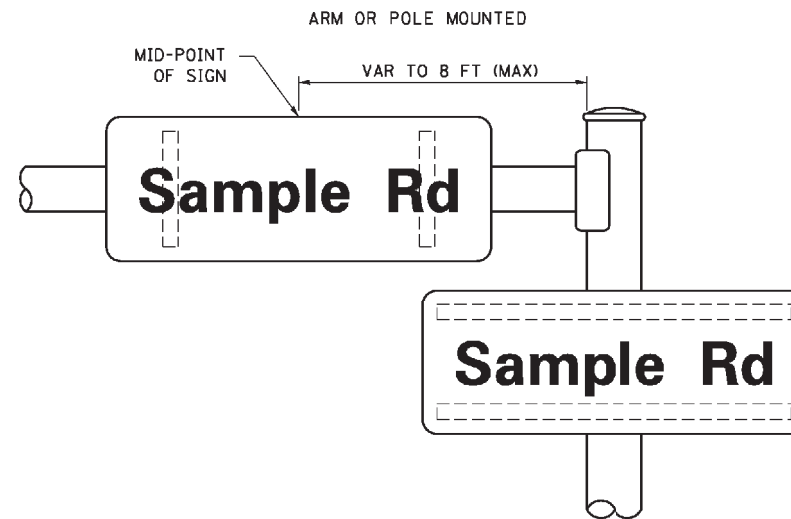

**SUPPORTING CHANNELS**

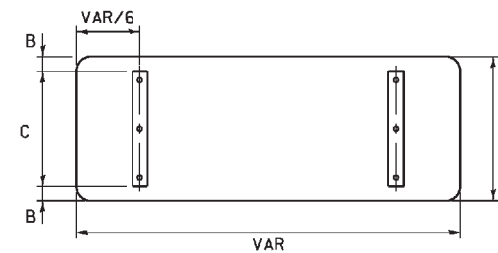

A	B	C
18"	2"	14"
30"	2"	24"

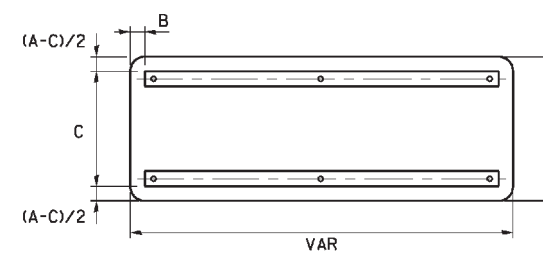

A	B	C
18"	2"	12"
30"	2"	22"

**STANDARD ALPHABETS SPACING CHART**

(8") UPPER CASE AND (6") LOWER CASE

CHARACTER	FHWA SERIES "C"			FHWA SERIES "D"			
	LEFT SPACING (INCH)	WIDTH (INCH)	RIGHT SPACING (INCH)	CHARACTER	LEFT SPACING (INCH)	WIDTH (INCH)	RIGHT SPACING (INCH)
A	0.240	5.122	0.240	A	0.240	6.804	0.240
B	0.880	4.482	0.480	B	0.960	5.446	0.400
C	0.720	4.482	0.720	C	0.800	5.446	0.800
D	0.880	4.482	0.720	D	0.960	5.446	0.800
E	0.880	4.082	0.480	E	0.960	4.962	0.400
F	0.880	4.082	0.240	F	0.960	4.962	0.240
G	0.720	4.482	0.720	G	0.800	5.446	0.800
H	0.880	4.482	0.880	H	0.960	5.446	0.960
I	0.880	1.120	0.880	I	0.960	1.280	0.960
J	0.240	4.082	0.880	J	0.240	5.122	0.960
K	0.880	4.482	0.480	K	0.960	5.604	0.400
L	0.880	4.082	0.240	L	0.960	4.962	0.240
M	0.880	5.284	0.880	M	0.960	6.244	0.960
N	0.880	4.482	0.880	N	0.960	5.446	0.960
O	0.720	4.722	0.720	O	0.800	5.684	0.800
P	0.880	4.482	0.720	P	0.960	5.446	0.240
Q	0.720	4.722	0.720	Q	0.800	5.684	0.800
R	0.880	4.482	0.480	R	0.960	5.446	0.400
S	0.480	4.482	0.480	S	0.400	5.446	0.400
T	0.240	4.082	0.240	T	0.240	4.962	0.240
U	0.880	4.482	0.880	U	0.960	5.446	0.960
V	0.240	4.962	0.240	V	0.240	6.084	0.240
W	0.240	6.084	0.240	W	0.240	7.124	0.240
X	0.240	4.722	0.240	X	0.400	5.446	0.400
Y	0.240	5.122	0.240	Y	0.240	6.884	0.240
Z	0.480	4.482	0.480	Z	0.400	5.446	0.400
a	0.320	3.842	0.640	a	0.400	4.562	0.720
b	0.720	4.082	0.480	b	0.800	4.802	0.480
c	0.480	4.002	0.240	c	0.480	4.722	0.240
d	0.480	4.082	0.720	d	0.480	4.802	0.800
e	0.480	4.082	0.320	e	0.480	4.722	0.320
f	0.320	2.480	0.160	f	0.320	2.882	0.160
g	0.480	4.082	0.720	g	0.480	4.802	0.800
h	0.720	4.082	0.640	h	0.800	4.722	0.720
i	0.720	1.120	0.720	i	0.800	1.280	0.800
j	0.000	2.320	0.720	j	0.000	2.642	0.800
k	0.720	4.322	0.160	k	0.800	5.122	0.160
l	0.720	1.120	0.720	l	0.800	1.280	0.800
m	0.720	6.724	0.640	m	0.800	7.926	0.720
n	0.720	4.082	0.640	n	0.800	4.722	0.720
o	0.480	4.082	0.480	o	0.480	4.882	0.480
p	0.720	4.082	0.480	p	0.800	4.802	0.480
q	0.480	4.082	0.720	q	0.480	4.802	0.800
r	0.720	2.642	0.160	r	0.800	3.042	0.160
s	0.320	3.362	0.240	s	0.320	3.762	0.240
t	0.080	2.882	0.080	t	0.080	3.202	0.080
u	0.640	4.082	0.720	u	0.720	4.722	0.800
v	0.160	4.722	0.160	v	0.160	5.684	0.160
w	0.160	7.524	0.160	w	0.160	9.046	0.160
x	0.000	5.202	0.000	x	0.000	6.244	0.000
y	0.160	4.962	0.160	y	0.160	6.004	0.160
z	0.240	3.362	0.240	z	0.240	4.002	0.240
1	0.720	1.680	0.880	1	0.800	2.000	0.960
2	0.480	4.482	0.480	2	0.800	5.446	0.800
3	0.480	4.482	0.480	3	1.440	5.446	0.800
4	0.240	4.962	0.720	4	0.160	6.004	0.960
5	0.480	4.482	0.480	5	0.800	5.446	0.800
6	0.720	4.482	0.720	6	0.800	5.446	0.800
7	0.240	4.482	0.720	7	0.560	5.446	0.560
8	0.480	4.482	0.480	8	0.800	5.446	0.800
9	0.480	4.482	0.480	9	0.800	5.446	0.800
0	0.720	4.722	0.720	0	0.800	5.684	0.800
-	0.240	2.802	0.240	-	0.240	2.802	0.240

TS SHT NO. 8

**REMOVAL AND RELOCATION NOTES:**

THE FOLLOWING ITEMS SHALL BE REMOVED BY THE CONTRACTOR AND SHALL BE DISPOSED OF BY THEM OUTSIDE THE RIGHT-OF-WAY AT THEIR EXPENSE. THE SALVAGE VALUE OF THE REMOVED EQUIPMENT SHALL BE REFLECTED IN THE CONTRACT BID PRICE.

- 2 EACH STEEL MAST ARM ASSEMBLY AND POST
- 4 EACH TRAFFIC SIGNAL POST
- 5 EACH 3-SECTION SIGNAL HEAD
- 4 EACH 4-SECTION SIGNAL HEAD
- 2 EACH 5-SECTION SIGNAL HEAD
- 6 EACH PEDESTRIAN SIGNAL HEAD
- 4 EACH PEDESTRIAN PUSH-BUTTON
- 1 EACH SERVICE INSTALLATION
- 4 EACH TRAFFIC SIGNAL BACKPLATE
- 1 EACH TRAFFIC SIGNAL CABINET

THE FOLLOWING EXISTING TRAFFIC SIGNAL EQUIPMENT SHALL BE REMOVED BY THE CONTRACTOR AND SHALL REMAIN THE PROPERTY OF THE AGENCY LISTED BELOW. THE CONTRACTOR SHALL SAFELY STORE AND ARRANGE FOR THE PICK UP OF ALL THE EQUIPMENT TO BE RETURNED TO THE LISTED AGENCY.

- NAME OF AGENCY: CITY OF AURORA  
DEPARTMENT: ELECTRICAL DEPARTMENT
- 1 EACH WIRELESS INTERCONNECT INSTALLATION
  - 2 EACH CONFIRMATION BEACON
  - 2 EACH LIGHT DETECTOR

- NAME OF AGENCY: ILLINOIS DEPARTMENT OF TRANSPORTATION
- 1 EACH TRAFFIC SIGNAL CONTROLLER
  - 1 EACH UPS INSTALLATION

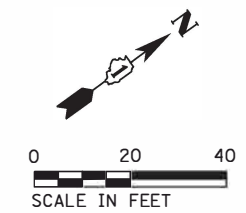

NOTES:  
THE TRAFFIC SIGNAL CONTROLLER EQUIPMENT FOR THIS PROJECT SHALL BE "ECONOLITE" TO MATCH THE EXISTING ADJACENT SYSTEM.

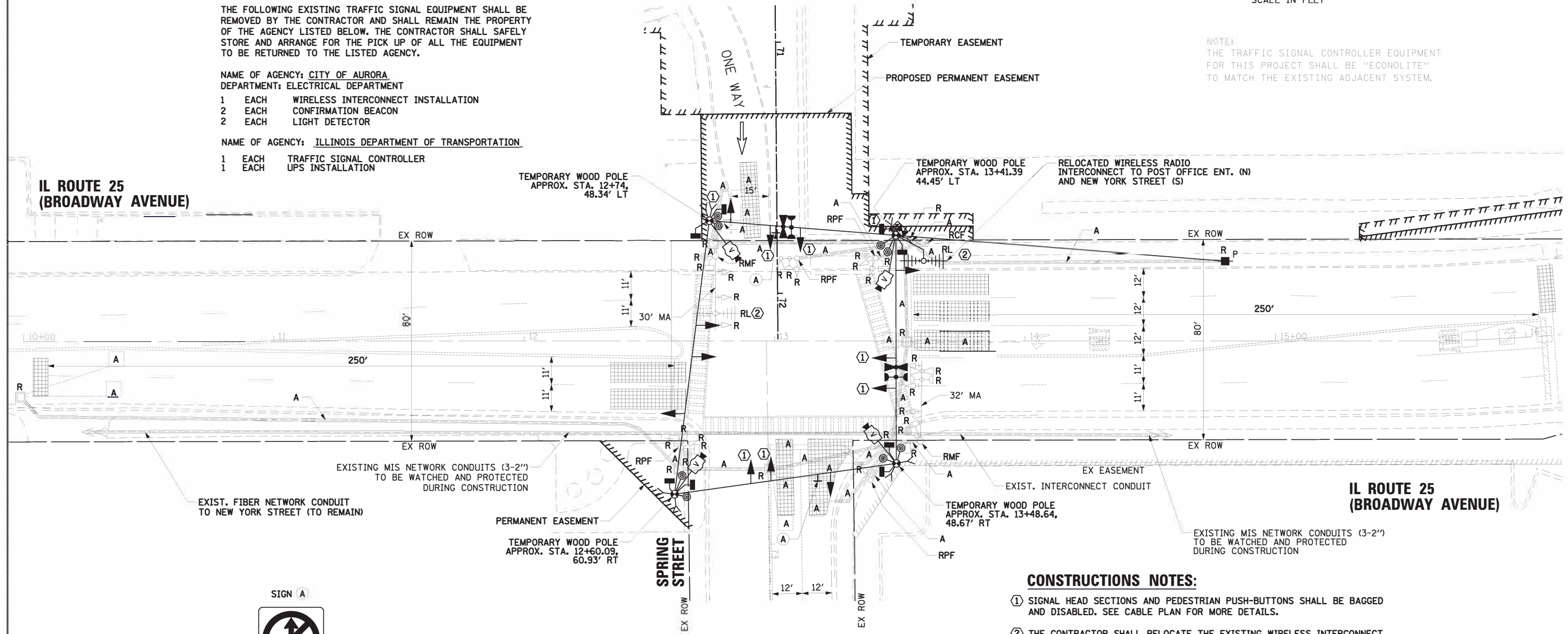

**IL ROUTE 25  
(BROADWAY AVENUE)**

**IL ROUTE 25  
(BROADWAY AVENUE)**

**SPRING STREET**

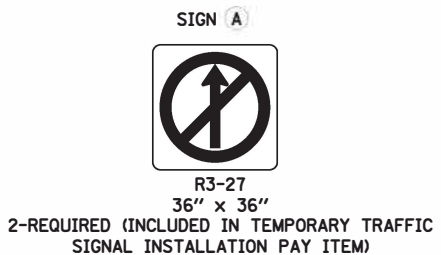

**CONSTRUCTIONS NOTES:**

- ① SIGNAL HEAD SECTIONS AND PEDESTRIAN PUSH-BUTTONS SHALL BE BAGGED AND DISABLED. SEE CABLE PLAN FOR MORE DETAILS.
- ② THE CONTRACTOR SHALL RELOCATE THE EXISTING WIRELESS INTERCONNECT FOR IL 25 (NEW YORK STREET TO POST OFFICE ENT) TO THE TEMPORARY TRAFFIC SIGNAL INSTALLATION AND THEN REMOVE THE EQUIPMENT ONCE THE PROJECT IS COMPLETE AND RETURN IT TO THE CITY OF AURORA. ALL COSTS ASSOCIATED WITH RELOCATING AND REMOVING THE WIRELESS EQUIPMENT SHALL BE INCLUDED IN THE UNIT COST OF PAY ITEM: TEMPORARY TRAFFIC SIGNAL INSTALLATION

**EXISTING GEOMETRY**

TS SHT NO. 9

TS# 816

FILE NAME: \\cbbeldft\WBK\150077.2\Trf	USER NAME: bweich	DESIGNED: EAJ	REVISED:	<b>STATE OF ILLINOIS DEPARTMENT OF TRANSPORTATION</b>	<b>TEMPORARY TRAFFIC SIGNAL INSTALLATION PLAN AND EXISTING TRAFFIC SIGNAL EQUIPMENT REMOVAL PLAN IL ROUTE 25 (BROADWAY AVENUE) AND SPRING STREET</b>	F.A.U. RTE.:	SECTION:	COUNTY:	TOTAL SHEETS:	SHEET NO.:
PLT SCALE: 48'	CHECKED: TFS	REVISED:	2503			16-00313-00-MS	KANE	254	116	
PLT DATE: 10/17/2017	DATE: 10/17/2017	REVISED:	CONTRACT NO.							
SCALE: 48' SHEET OF 254 SHEETS STA. TO STA.						ILLINOIS FED. AID PROJECT				



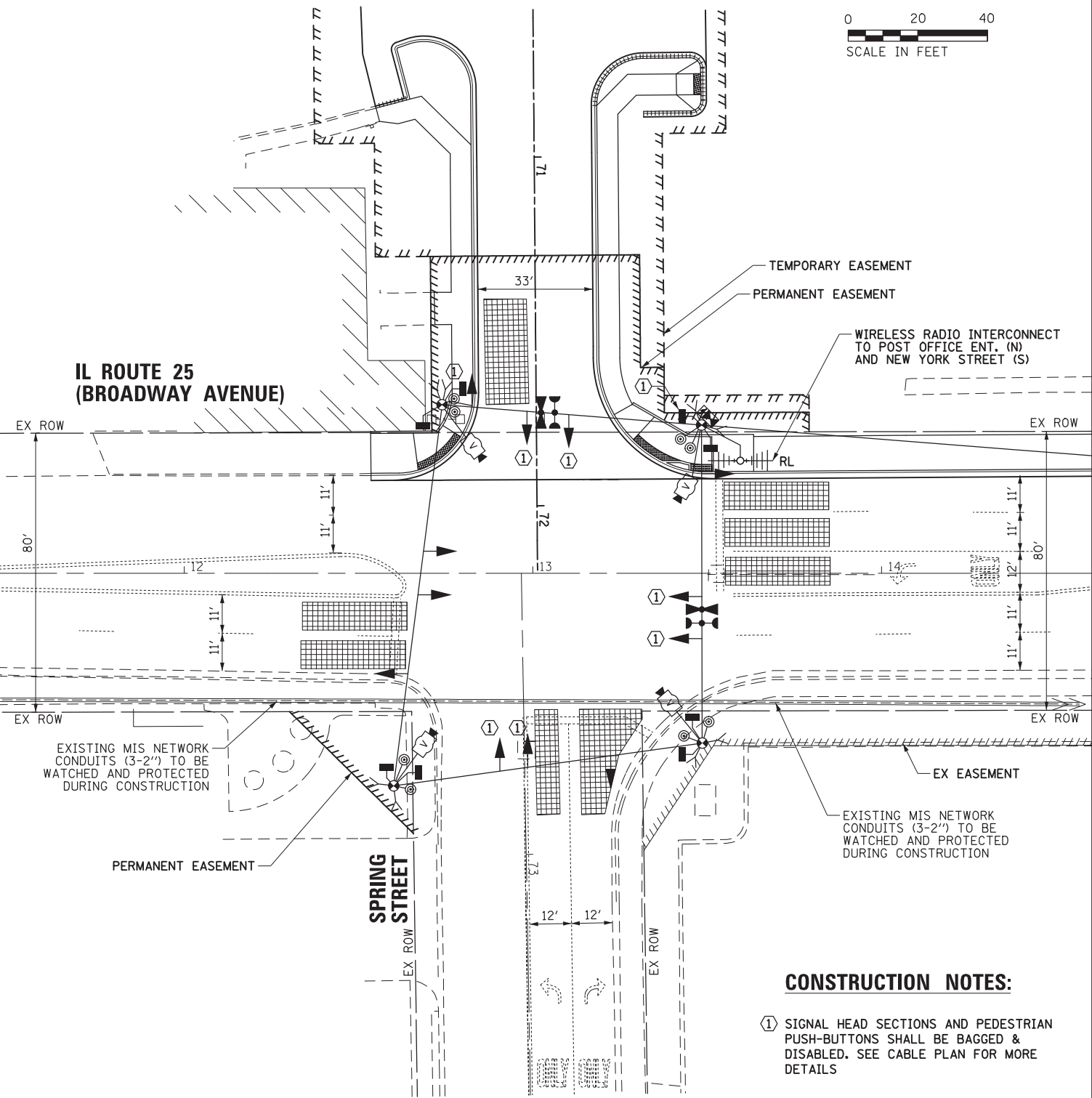
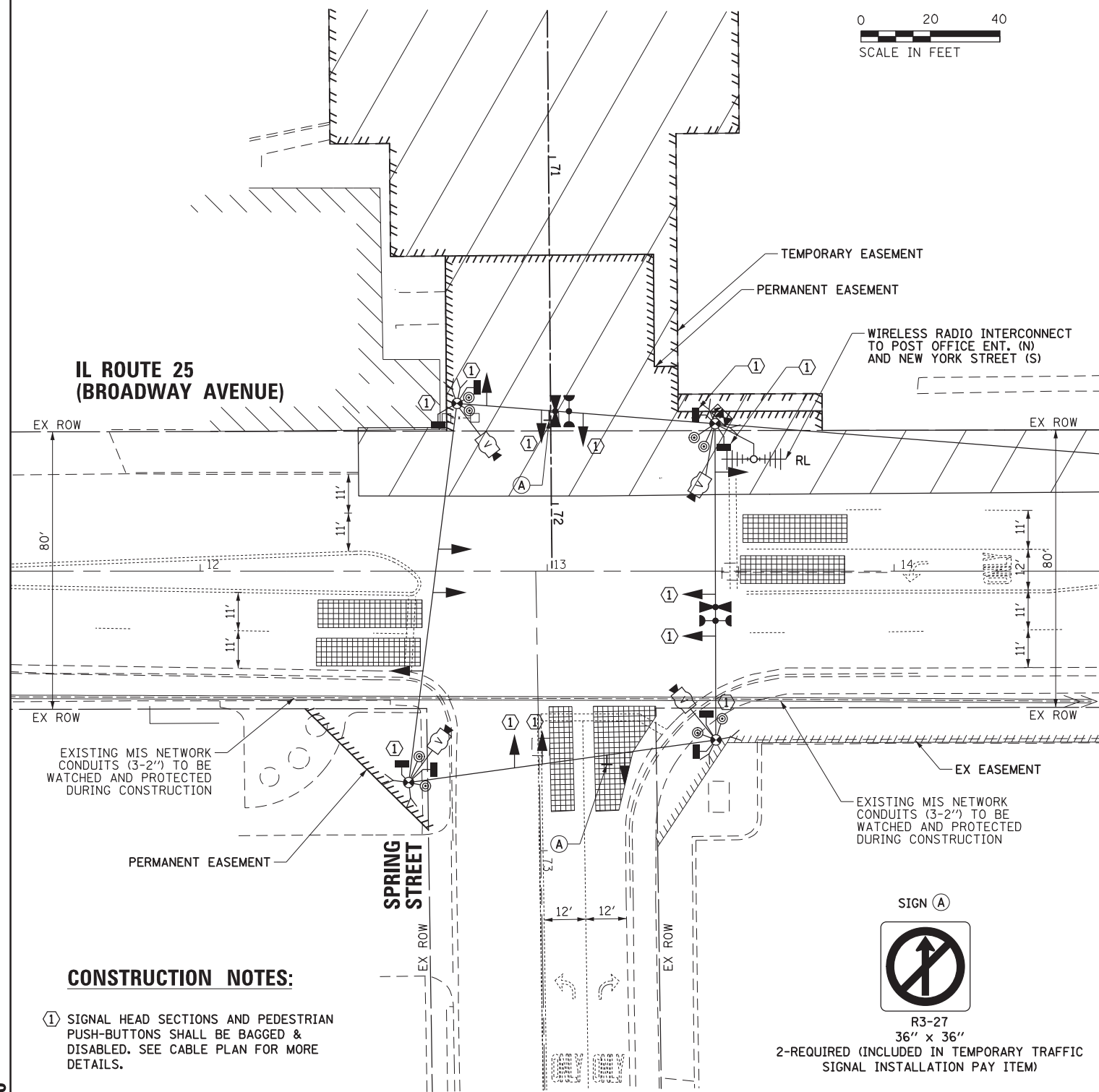
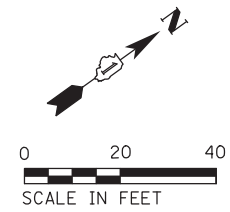
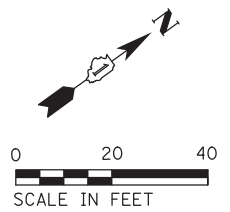

**CONSTRUCTION NOTES:**

- ① SIGNAL HEAD SECTIONS AND PEDESTRIAN PUSH-BUTTONS SHALL BE BAGGED & DISABLED. SEE CABLE PLAN FOR MORE DETAILS.

SIGN (A)



R3-27  
36" x 36"  
2-REQUIRED (INCLUDED IN TEMPORARY TRAFFIC SIGNAL INSTALLATION PAY ITEM)

**CONSTRUCTION NOTES:**

- ① SIGNAL HEAD SECTIONS AND PEDESTRIAN PUSH-BUTTONS SHALL BE BAGGED & DISABLED. SEE CABLE PLAN FOR MORE DETAILS.

**MOT STAGE 1**

**MOT STAGE 2, 3, & 4**

TS SHT NO. 10

TS# 816

FILE NAME =	USER NAME = bweich	DESIGNED - EAJ	REVISED -
\\cbbelrvt\cbbeldf\WBK\150077.2\Traffic\TS02-MOT_Stage 1&234_Spring.dgn		DRAWN - FPB	REVISED -
Default	PLOT SCALE = 40'	CHECKED - TFS	REVISED -
	PLOT DATE = 10/17/2017	DATE - 10/17/2017	REVISED -

STATE OF ILLINOIS  
DEPARTMENT OF TRANSPORTATION

<b>TEMPORARY TRAFFIC SIGNAL STAGING DIAGRAM</b>			
<b>MOT STAGE 1, 2, 3, &amp; 4</b>			
<b>IL ROUTE 25 (BROADWAY AVENUE) AND SPRING STREET</b>			
SCALE: 40'	SHEET	OF 254 SHEETS	STA. TO STA.

F.A.U. RTE.	SECTION	COUNTY	TOTAL SHEETS	SHEET NO.
2503	16-00313-00-MS	KANE	254	117
				CONTRACT NO.
ILLINOIS FED. AID PROJECT				

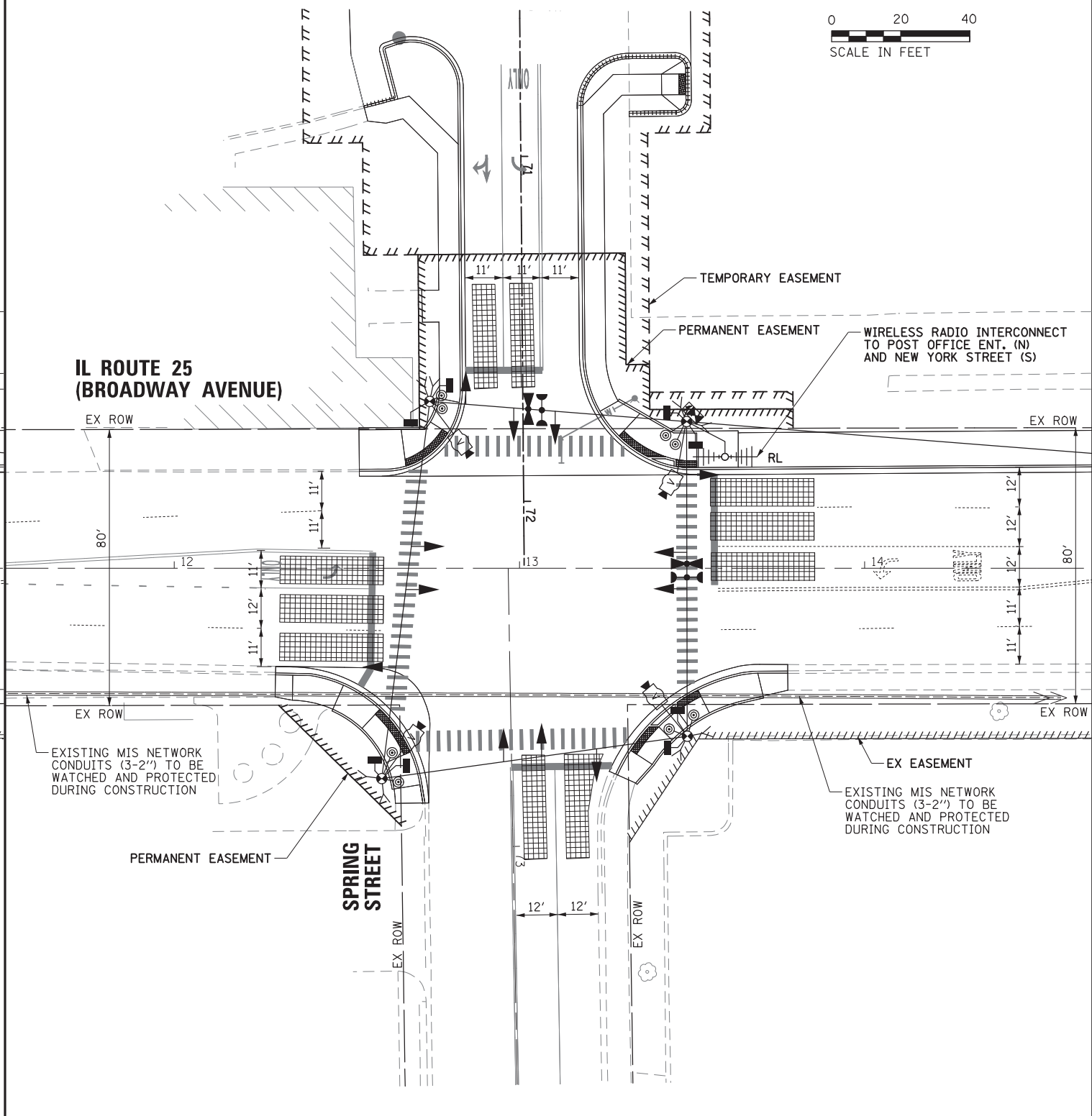
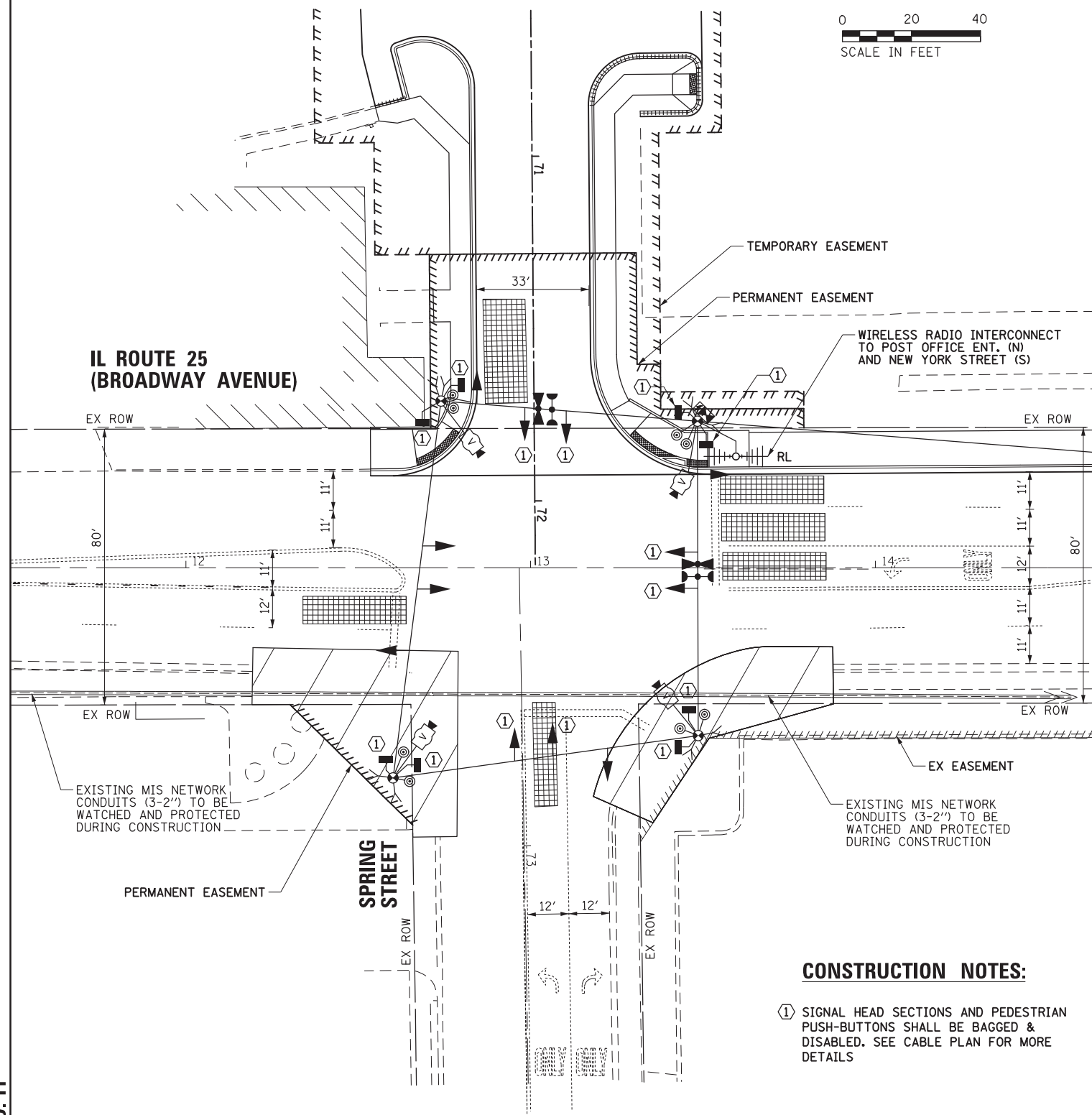
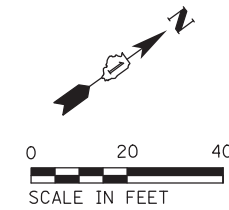
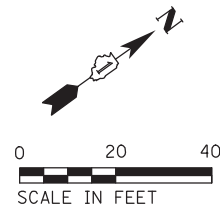

**CONSTRUCTION NOTES:**

① SIGNAL HEAD SECTIONS AND PEDESTRIAN PUSH-BUTTONS SHALL BE BAGGED & DISABLED. SEE CABLE PLAN FOR MORE DETAILS

**MOT STAGE 5**

**FINAL GEOMETRY**

TS SHT NO. 11

TS# 816

FILE NAME =	USER NAME = bweich	DESIGNED - EAJ	REVISED -
\\cbbelrvt\cbbelrvt\WBK\150077.2\Traffic\TS03-MOT-Stage 5&FINAL_Spring.dgn		DRAWN - FPB	REVISED -
Default	PLOT SCALE = 40'	CHECKED - TFS	REVISED -
	PLOT DATE = 10/17/2017	DATE - 10/17/2017	REVISED -

STATE OF ILLINOIS  
DEPARTMENT OF TRANSPORTATION

TEMPORARY TRAFFIC SIGNAL STAGING DIAGRAM  
MOT STAGE 5 AND FINAL GEOMETRY  
IL ROUTE 25 (BROADWAY AVENUE) AND SPRING STREET

SCALE: 40' SHEET OF 254 SHEETS STA. TO STA.

F.A.U. RTE.	SECTION	COUNTY	TOTAL SHEETS	SHEET NO.
2503	16-00313-00-MS	KANE	254	118
CONTRACT NO.				
ILLINOIS FED. AID PROJECT				

**TEMPORARY CONTROLLER SEQUENCE**

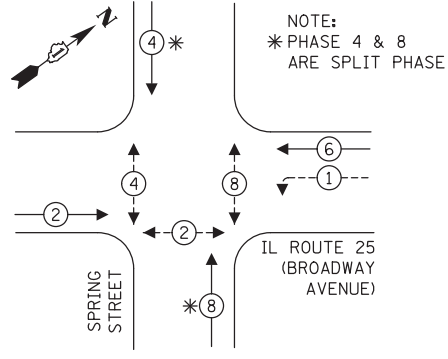

**LEGEND:**

- ← \* → PROTECTED PHASE
- ← \* - - → PROTECTED/PERMITTED PHASE
- ← \* - - - - → PEDESTRIAN PHASE
- ← \* OL → OVERLAP

**TEMPORARY EMERGENCY VEHICLE PREEMPTION SEQUENCE**

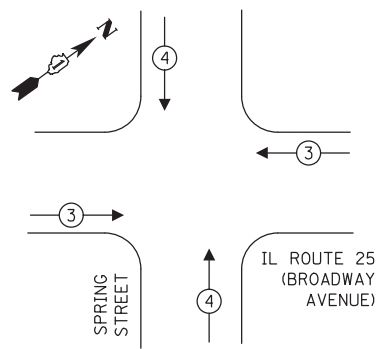

**IL ROUTE 25 (BROADWAY AVENUE)**

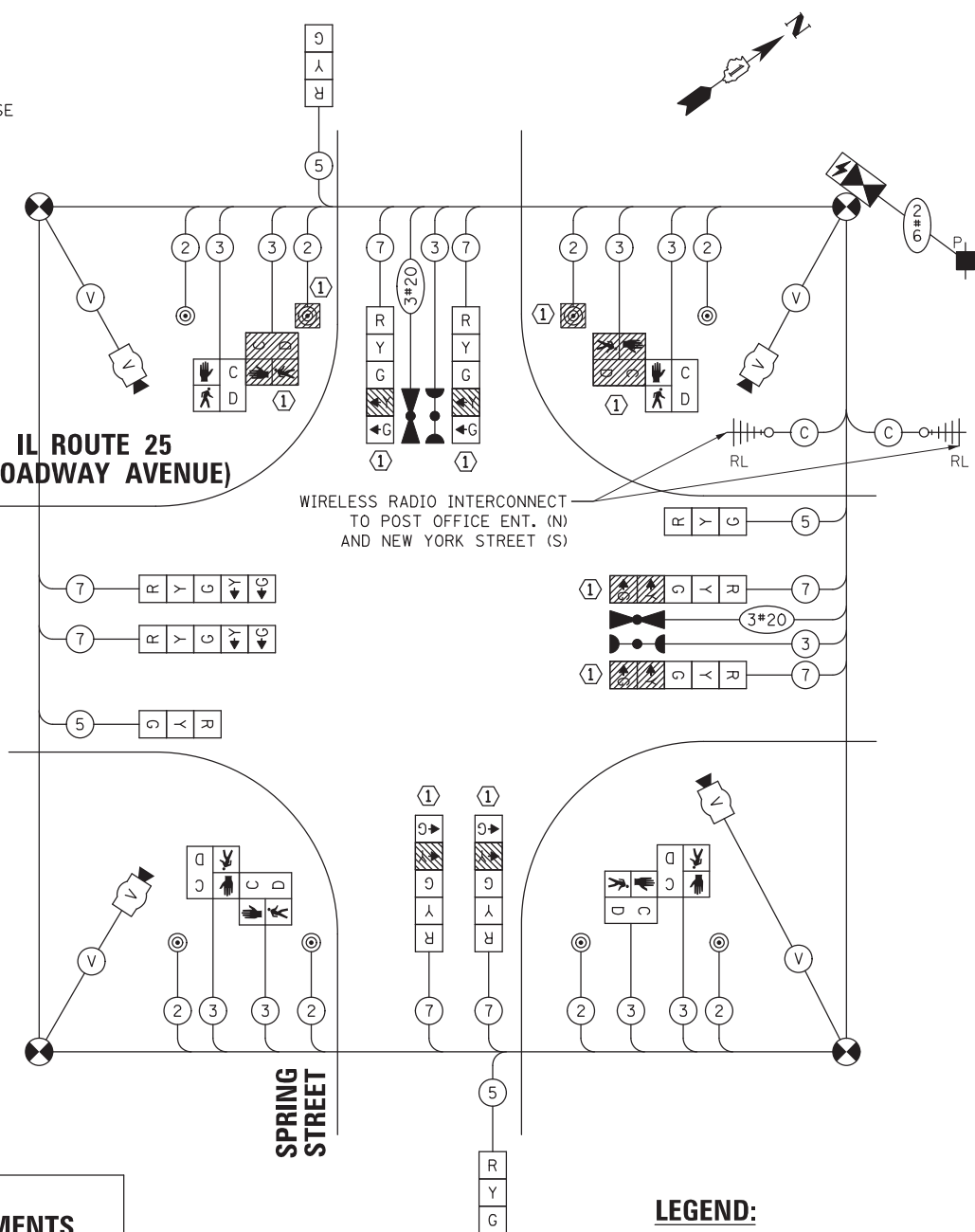

**LEGEND:**

- ▨ = BAGGED AND DISABLED

**EXISTING GEOMETRY TEMPORARY CABLE PLAN**  
(NOT TO SCALE)

**CONSTRUCTION NOTES:**

- ① SIGNAL HEAD SECTIONS AND PEDESTRIAN PUSH-BUTTONS SHALL BE BAGGED AND DISABLED.

**TEMPORARY CONTROLLER SEQUENCE**

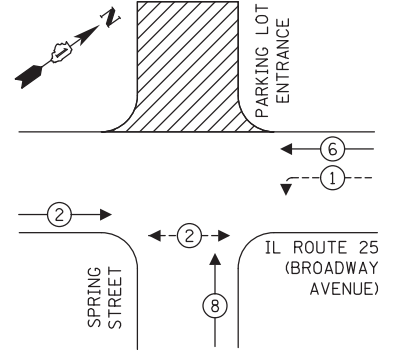

**LEGEND:**

- ← \* → PROTECTED PHASE
- ← \* - - → PROTECTED/PERMITTED PHASE
- ← \* - - - - → PEDESTRIAN PHASE
- ← \* OL → OVERLAP

**TEMPORARY EMERGENCY VEHICLE PREEMPTION SEQUENCE**

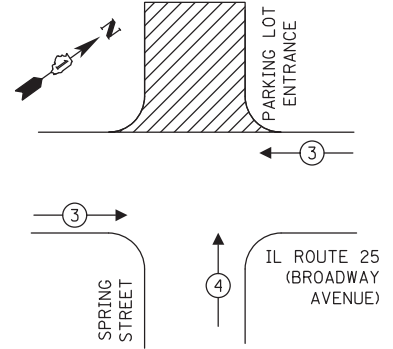

**IL ROUTE 25 (BROADWAY AVENUE)**

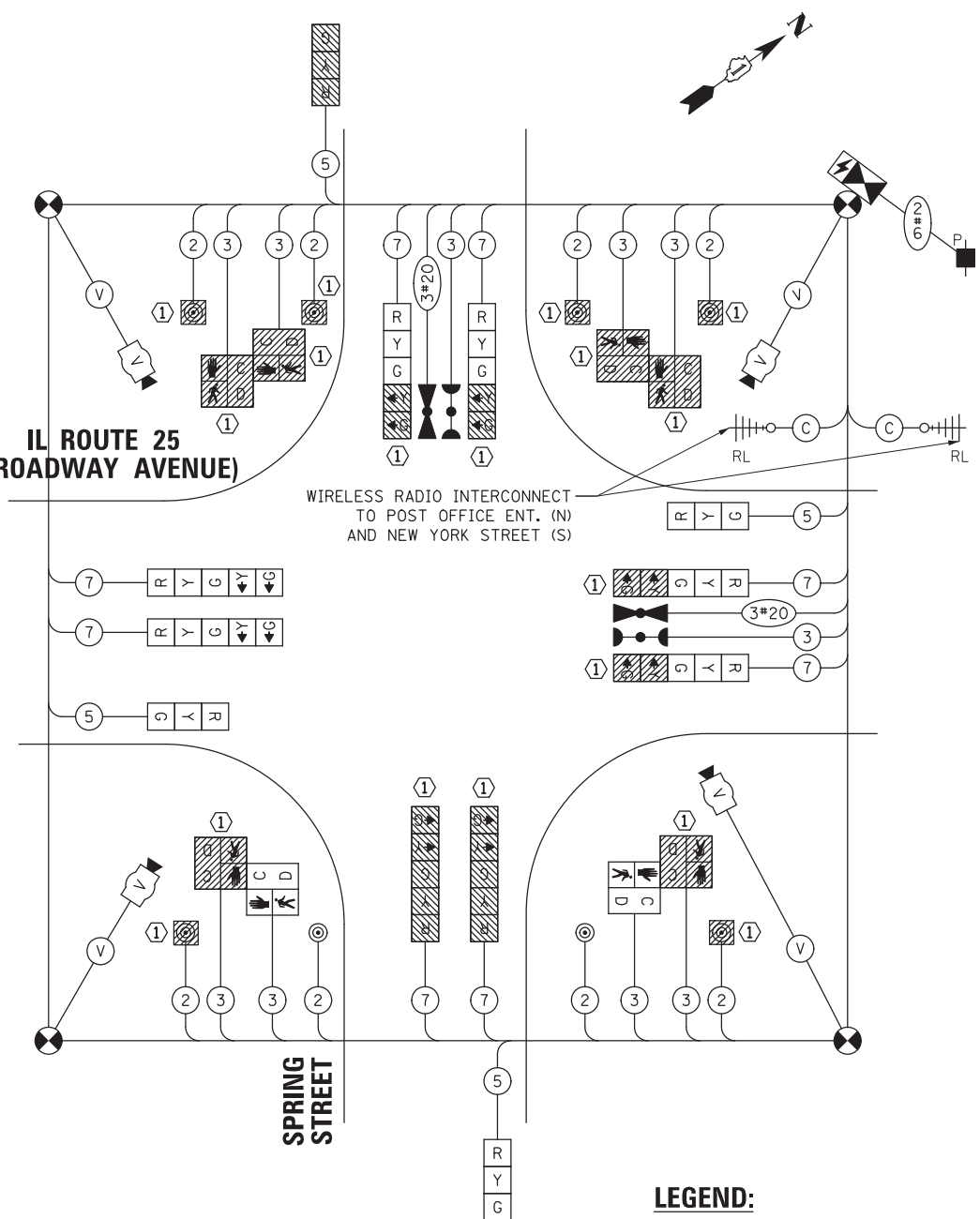

**LEGEND:**

- ▨ = BAGGED AND DISABLED

**MOT STAGE 1 TEMPORARY CABLE PLAN**  
(NOT TO SCALE)

**CONSTRUCTION NOTES:**

- ① SIGNAL HEAD SECTIONS AND PEDESTRIAN PUSH-BUTTONS SHALL BE BAGGED AND DISABLED.

NOTE:  
THE TRAFFIC SIGNAL CONTROLLER EQUIPMENT FOR THIS PROJECT SHALL BE "ECONOLITE" TO MATCH THE EXISTING ADJACENT SYSTEM.

**TRAFFIC SIGNAL ELECTRICAL SERVICE REQUIREMENTS**

TYPE	NO. OF LAMPS	LED WATTAGE	% OPERATION	TOTAL WATTAGE
SIGNAL (RED)	12	11	50	66.0
(YELLOW)	12	20	5	12.0
(GREEN)	12	12	45	64.8
PERMISSIVE ARROW	8	10	10	8.0
PED. SIGNAL	8	20	100	160.0
CONTROLLER	1	100	100	100.0
UPS	1	25	100	25.0
VIDEO SYSTEM	1	150	100	150.0
BLANK-OUT SIGN	-	25	5	-
FLASHER	-	-	50	-
STREET NAME SIGN	-	120	50	-
LUMINAIRE	-	-	-	-
TOTAL =				585.8

ENERGY COSTS TO:  
ILLINOIS DEPARTMENT OF TRANSPORTATION  
DIVISION OF HIGHWAY/DISTRICT 1  
201 WEST CENTER COURT/SCHAUMBURG, ILLINOIS 60196-1096  
ENERGY SUPPLY: CONTACT: NEW BUSINESS  
PHONE: NEW PHONE  
COMPANY: COMMONWEALTH EDISON  
ACCOUNT NUMBER: ---

TS SHT NO. 12

FILE NAME =	USER NAME = bweich
\\cbbel\svr1\cbbel\df\WBK\150077.2\Traffic\TS04-TCB_Stage-EX&I.Spring.dgn	
Default	PLOT DATE = 10/17/2017

DESIGNED - EAJ	REVISED -
DRAWN - FPB	REVISED -
CHECKED - TFS	REVISED -
DATE - 10/17/2017	REVISED -

STATE OF ILLINOIS  
DEPARTMENT OF TRANSPORTATION

TEMPORARY CABLE PLAN, TEMPORARY PHASE DESIGNATION DIAGRAM  
AND TEMPORARY EMERGENCY VEHICLE PREEMPTION SEQUENCE  
IL ROUTE 25 (BROADWAY AVENUE) AND SPRING STREET

SCALE: N.T.S. SHEET OF 254 SHEETS STA. TO STA.

F.A.U. RTE.	SECTION	COUNTY	TOTAL SHEETS	SHEET NO.
2503	16-00313-00-MS	KANE	254	119
CONTRACT NO.				
ILLINOIS FED. AID PROJECT				

TS# 816

**TEMPORARY CONTROLLER SEQUENCE**

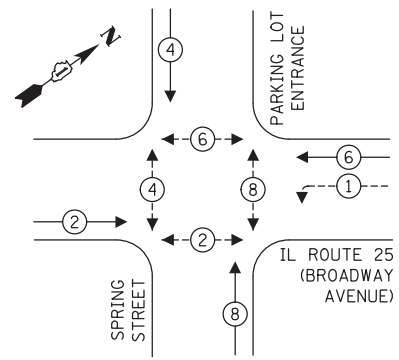

**LEGEND:**

- ← \* → PROTECTED PHASE
- ← \* - - \* → PROTECTED/PERMITTED PHASE
- ← \* → PEDESTRIAN PHASE
- ← \* OL → OVERLAP

**TEMPORARY EMERGENCY VEHICLE PREEMPTION SEQUENCE**

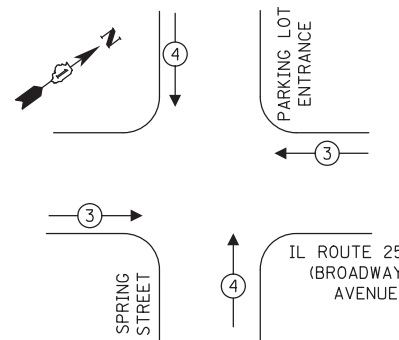

**TRAFFIC SIGNAL ELECTRICAL SERVICE REQUIREMENTS**

TYPE	NO. OF LAMPS	LED WATTAGE	% OPERATION	TOTAL WATTAGE
SIGNAL (RED)	12	11	50	66.0
(YELLOW)	12	20	5	12.0
(GREEN)	12	12	45	64.8
PERMISSIVE ARROW	8	10	10	8.0
PED. SIGNAL	8	20	100	160.0
CONTROLLER	1	100	100	100.0
UPS	1	25	100	25.0
VIDEO SYSTEM	1	150	100	150.0
BLANK-OUT SIGN	-	25	5	-
FLASHER	-	-	50	-
STREET NAME SIGN	-	120	50	-
LUMINAIRE	-	-	-	-
TOTAL =				585.8

ENERGY COSTS TO:

ILLINOIS DEPARTMENT OF TRANSPORTATION  
DIVISION OF HIGHWAY/DISTRICT 1  
201 WEST CENTER COURT/SCHAUMBURG, ILLINOIS 60196-1096

ENERGY SUPPLY: CONTACT: NEW BUSINESS  
PHONE: NEW PHONE  
COMPANY: COMMONWEALTH EDISON  
ACCOUNT NUMBER: ---

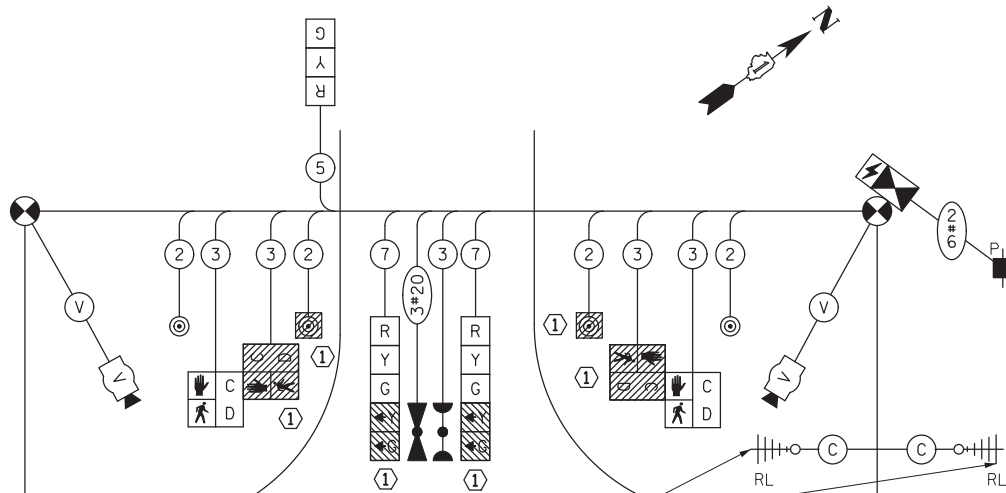

**IL ROUTE 25 (BROADWAY AVENUE)**

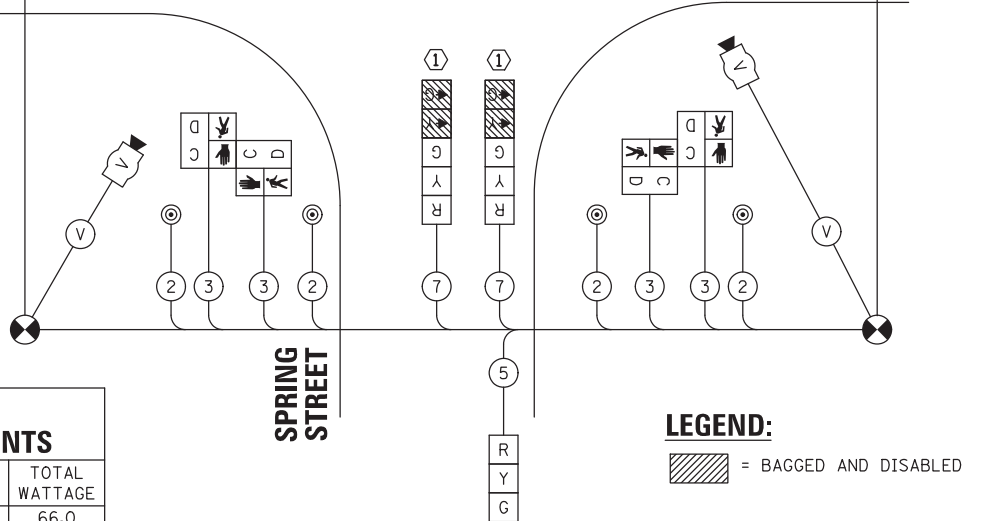
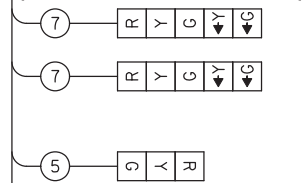

**IL ROUTE 25 (BROADWAY AVENUE)**

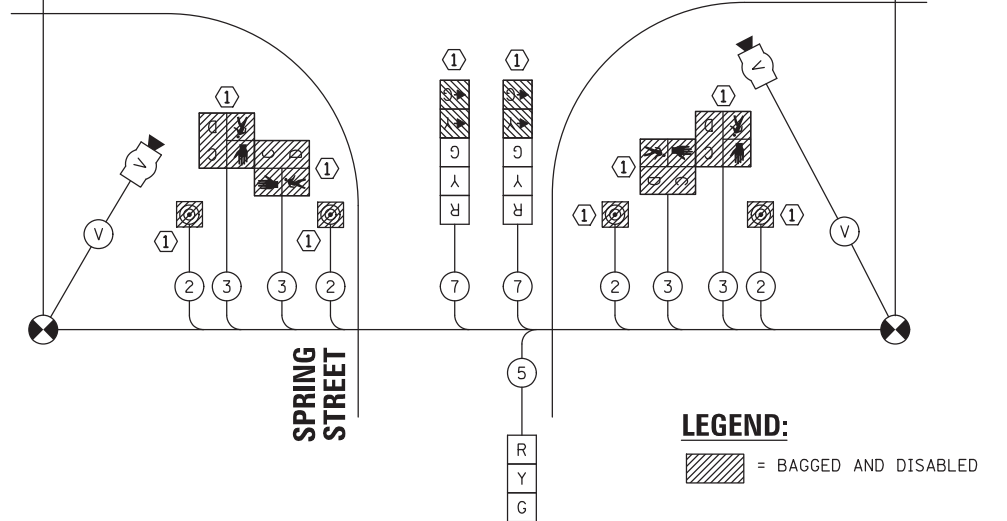
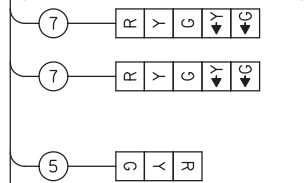

**MOT STAGE 2, 3, & 4 TEMPORARY CABLE PLAN**  
(NOT TO SCALE)

**CONSTRUCTION NOTES:**

- ① SIGNAL HEAD SECTIONS AND PEDESTRIAN PUSH-BUTTONS SHALL BE BAGGED AND DISABLED.

**TEMPORARY CONTROLLER SEQUENCE**

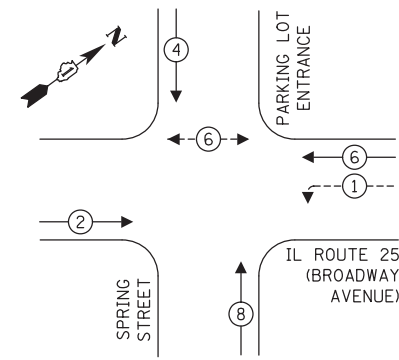

**LEGEND:**

- ← \* → PROTECTED PHASE
- ← \* - - \* → PROTECTED/PERMITTED PHASE
- ← \* → PEDESTRIAN PHASE
- ← \* OL → OVERLAP

**TEMPORARY EMERGENCY VEHICLE PREEMPTION SEQUENCE**

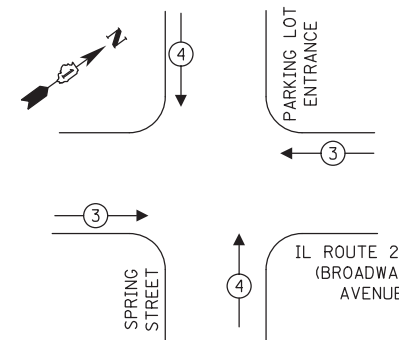

**TRAFFIC SIGNAL ELECTRICAL SERVICE REQUIREMENTS**

TYPE	NO. OF LAMPS	LED WATTAGE	% OPERATION	TOTAL WATTAGE
SIGNAL (RED)	12	11	50	66.0
(YELLOW)	12	20	5	12.0
(GREEN)	12	12	45	64.8
PERMISSIVE ARROW	8	10	10	8.0
PED. SIGNAL	8	20	100	160.0
CONTROLLER	1	100	100	100.0
UPS	1	25	100	25.0
VIDEO SYSTEM	1	150	100	150.0
BLANK-OUT SIGN	-	25	5	-
FLASHER	-	-	50	-
STREET NAME SIGN	-	120	50	-
LUMINAIRE	-	-	-	-
TOTAL =				585.8

ENERGY COSTS TO:

ILLINOIS DEPARTMENT OF TRANSPORTATION  
DIVISION OF HIGHWAY/DISTRICT 1  
201 WEST CENTER COURT/SCHAUMBURG, ILLINOIS 60196-1096

ENERGY SUPPLY: CONTACT: NEW BUSINESS  
PHONE: NEW PHONE  
COMPANY: COMMONWEALTH EDISON  
ACCOUNT NUMBER: ---

**MOT STAGE 5 TEMPORARY CABLE PLAN**  
(NOT TO SCALE)

**CONSTRUCTION NOTES:**

- ① SIGNAL HEAD SECTIONS AND PEDESTRIAN PUSH-BUTTONS SHALL BE BAGGED AND DISABLED.

NOTE:  
THE TRAFFIC SIGNAL CONTROLLER EQUIPMENT FOR THIS PROJECT SHALL BE "ECONOLITE" TO MATCH THE EXISTING ADJACENT SYSTEM.

TS SHT NO. 13

FILE NAME: \\cbbel\svr1\cbbel\df\WBK\150077.2\Traffic\TS05-TCB\_Stage 23485.dgn  
USER NAME: bweich  
PLOT SCALE: 48"  
PLOT DATE: 10/17/2017

DESIGNED - EAJ  
DRAWN - FPB  
CHECKED - TFS  
DATE - 10/17/2017

REVISED -  
REVISED -  
REVISED -  
REVISED -

STATE OF ILLINOIS  
DEPARTMENT OF TRANSPORTATION

TEMPORARY CABLE PLAN, TEMPORARY PHASE DESIGNATION DIAGRAM AND TEMPORARY EMERGENCY VEHICLE PREEMPTION SEQUENCE  
IL ROUTE 25 (BROADWAY AVENUE) AND SPRING STREET

SCALE: N&S. SHEET OF 254 SHEETS STA. TO STA.

F.A.U. RTE.	SECTION	COUNTY	TOTAL SHEETS	SHEET NO.
2503	16-00313-00-MS	KANE	254	120

CONTRACT NO. ILLINOIS FED. AID PROJECT

TS# 816

**TEMPORARY CONTROLLER SEQUENCE**

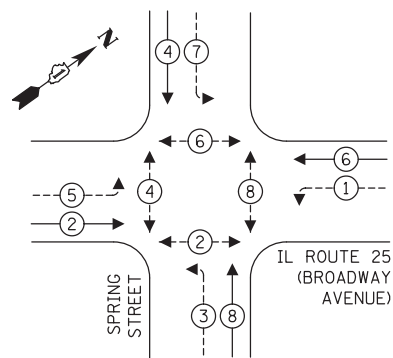

**LEGEND:**

- ← ⊙ — PROTECTED PHASE
- ← ⊙ - - - PROTECTED/PERMITTED PHASE
- ← ⊙ → PEDESTRIAN PHASE
- ← ⊙ OL OVERLAP

**TEMPORARY EMERGENCY VEHICLE PREEMPTION SEQUENCE**

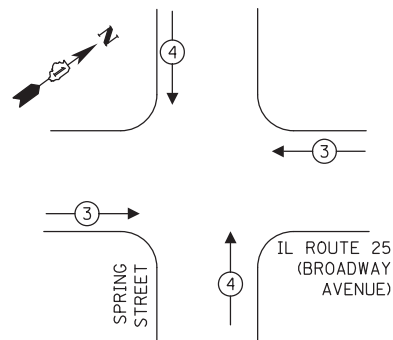

**TRAFFIC SIGNAL ELECTRICAL SERVICE REQUIREMENTS**

TYPE	NO. OF LAMPS	LED WATTAGE	% OPERATION	TOTAL WATTAGE
SIGNAL (RED)	12	11	50	66.0
(YELLOW)	12	20	5	12.0
(GREEN)	12	12	45	64.8
PERMISSIVE ARROW	8	10	10	8.0
PED. SIGNAL	8	20	100	160.0
CONTROLLER	1	100	100	100.0
UPS	1	25	100	25.0
VIDEO SYSTEM	1	150	100	150.0
BLANK-OUT SIGN	-	25	5	-
FLASHER	-	-	50	-
STREET NAME SIGN	-	120	50	-
LUMINAIRE	-	-	-	-
TOTAL =				585.8

ENERGY COSTS TO:

ILLINOIS DEPARTMENT OF TRANSPORTATION  
DIVISION OF HIGHWAY/DISTRICT 1  
201 WEST CENTER COURT/SCHAUMBURG, ILLINOIS 60196-1096

ENERGY SUPPLY: CONTACT: NEW BUSINESS  
PHONE: NEW PHONE  
COMPANY: COMMONWEALTH EDISON  
ACCOUNT NUMBER: ---

TS SHT NO. 14

FILE NAME =	USER NAME = bweich
\\cbbelserver\cbbel\df\WBK\150077.2\Traffic\1506-TCB_Final.Spring.dgn	
Default	PLOT DATE = 10/17/2017

DESIGNED - EAJ	REVISED -
DRAWN - FPB	REVISED -
CHECKED - TFS	REVISED -
DATE - 10/17/2017	REVISED -

**IL ROUTE 25 (BROADWAY AVENUE)**

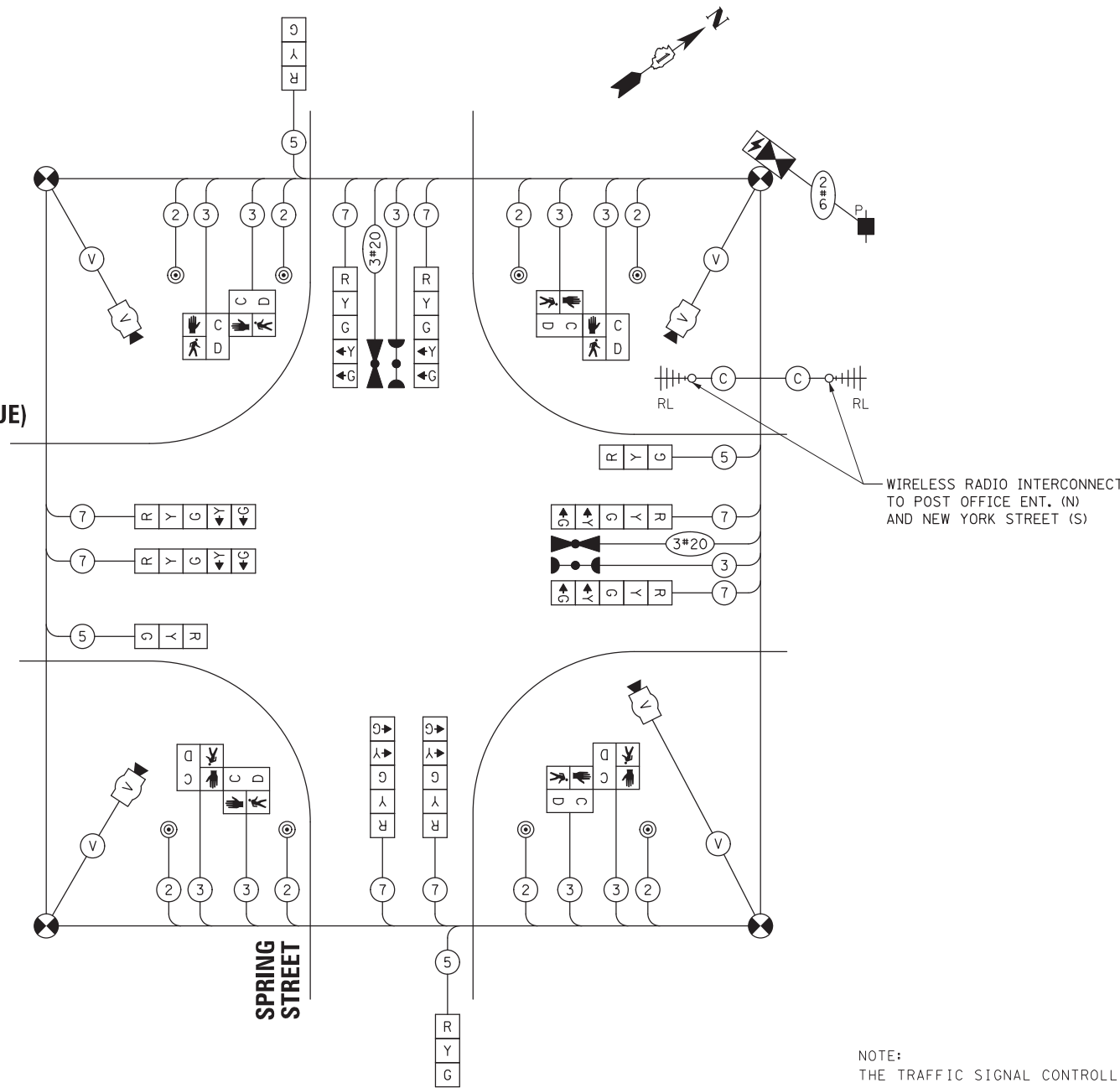

WIRELESS RADIO INTERCONNECT TO POST OFFICE ENT. (N) AND NEW YORK STREET (S)

**FINAL GEOMETRY TEMPORARY CABLE PLAN**  
(NOT TO SCALE)

NOTE:  
THE TRAFFIC SIGNAL CONTROLLER EQUIPMENT FOR THIS PROJECT SHALL BE "ECONOLITE" TO MATCH THE EXISTING ADJACENT SYSTEM.

STATE OF ILLINOIS  
DEPARTMENT OF TRANSPORTATION

TEMPORARY CABLE PLAN, TEMPORARY PHASE DESIGNATION DIAGRAM AND TEMPORARY EMERGENCY VEHICLE PREEMPTION SEQUENCE  
IL ROUTE 25 (BROADWAY AVENUE) AND SPRING STREET

SCALE: N.T.S. SHEET OF 254 SHEETS STA. TO STA.

F.A.U. RTE.	SECTION	COUNTY	TOTAL SHEETS	SHEET NO.
2503	16-00313-00-MS	KANE	254	121
				CONTRACT NO.
ILLINOIS FED. AID PROJECT				

TS# 816

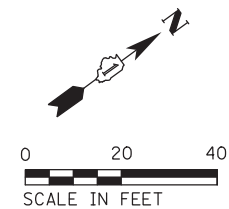

**NOTE:**  
THE TRAFFIC SIGNAL CONTROLLER EQUIPMENT FOR THIS PROJECT SHALL BE "ECONOLITE" TO MATCH THE EXISTING ADJACENT SYSTEM.

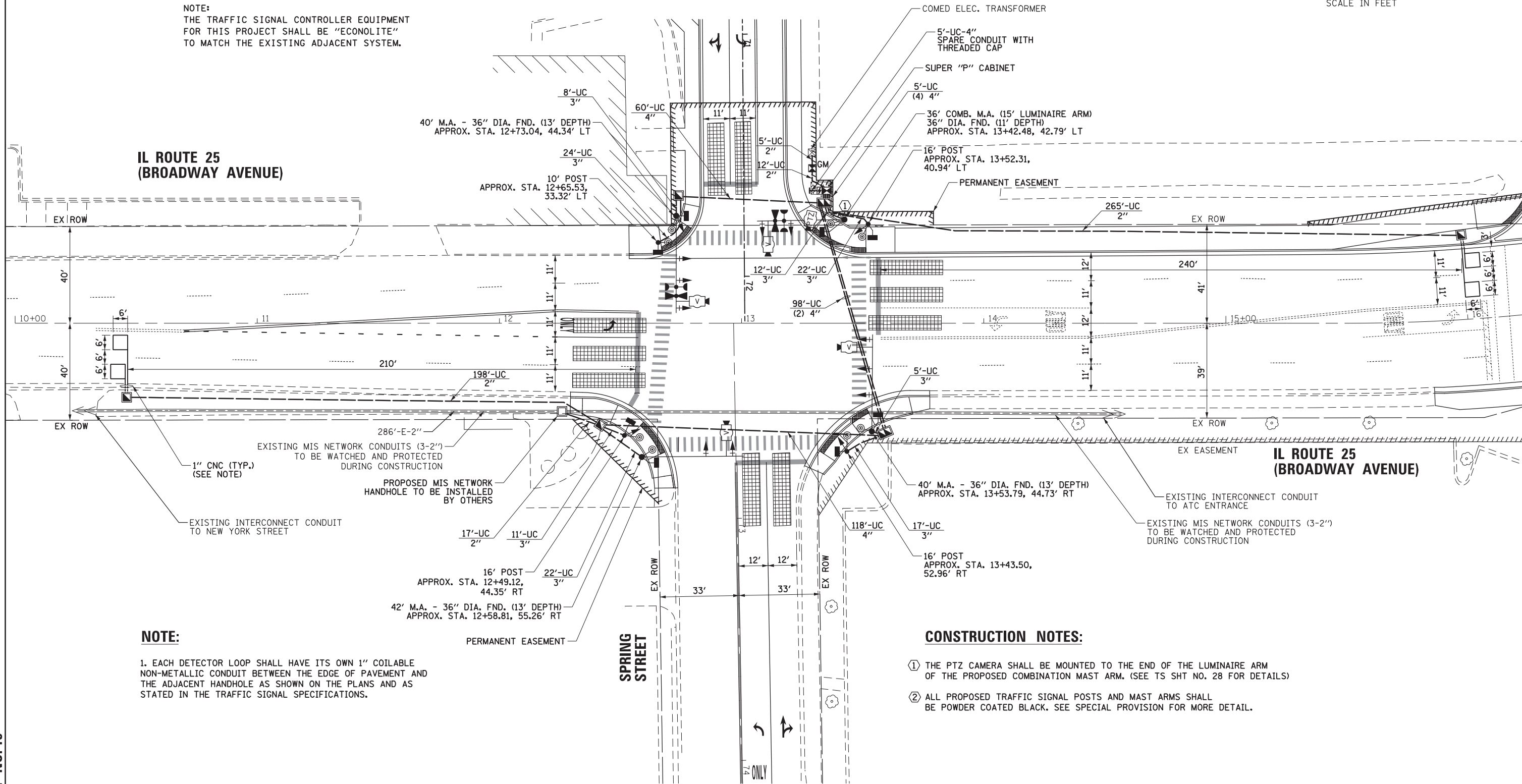

**IL ROUTE 25  
(BROADWAY AVENUE)**

**IL ROUTE 25  
(BROADWAY AVENUE)**

**SPRING STREET**

**NOTE:**

1. EACH DETECTOR LOOP SHALL HAVE ITS OWN 1" COILABLE NON-METALLIC CONDUIT BETWEEN THE EDGE OF PAVEMENT AND THE ADJACENT HANDHOLE AS SHOWN ON THE PLANS AND AS STATED IN THE TRAFFIC SIGNAL SPECIFICATIONS.

**CONSTRUCTION NOTES:**

- ① THE PTZ CAMERA SHALL BE MOUNTED TO THE END OF THE LUMINAIRE ARM OF THE PROPOSED COMBINATION MAST ARM. (SEE TS SHT NO. 28 FOR DETAILS)
- ② ALL PROPOSED TRAFFIC SIGNAL POSTS AND MAST ARMS SHALL BE POWDER COATED BLACK. SEE SPECIAL PROVISION FOR MORE DETAIL.

TS SHT NO. 15

TS# 816

FILE NAME = \\cbbel\svr\1\cbbel\dt\WBK\150077.2\Traffic\TS07-TSD-Spring.dgn	USER NAME = bweich	DESIGNED - EAJ	REVISED -	<b>STATE OF ILLINOIS DEPARTMENT OF TRANSPORTATION</b>	<b>TRAFFIC SIGNAL INSTALLATION PLAN IL ROUTE 25 (BROADWAY AVENUE) AND SPRING STREET</b>	F.A.U. RTE. 2503	SECTION 16-00313-00-MS	COUNTY KANE	TOTAL SHEETS 254	SHEET NO. 122		
Default	PLOT SCALE = 48"	CHECKED - TFS	REVISED -			SCALE: 48"	SHEET OF 254 SHEETS	STA. TO STA.	CONTRACT NO.			
	PLOT DATE = 10/17/2017	DATE - 10/17/2017	REVISED -			ILLINOIS FED. AID PROJECT						

**PROPOSED CONTROLLER SEQUENCE**

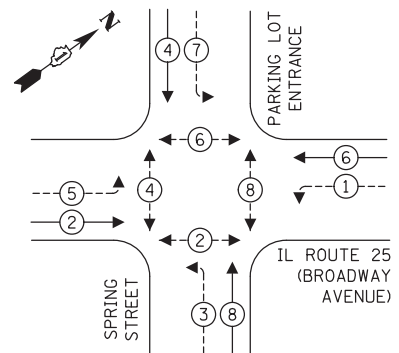

**LEGEND:**

- ← (circle with star) PROTECTED PHASE
- ← (circle with star and dashed line) PROTECTED/PERMITTED PHASE
- ← (circle with star and arrow) PEDESTRIAN PHASE
- ← (circle with star and OL) OVERLAP

**PROPOSED EMERGENCY VEHICLE PREEMPTION SEQUENCE**

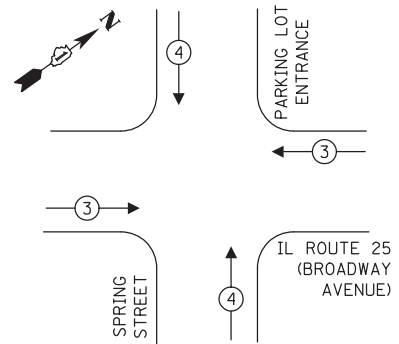

**TRAFFIC SIGNAL ELECTRICAL SERVICE REQUIREMENTS**

TYPE	NO. OF LAMPS	LED WATTAGE	% OPERATION	TOTAL WATTAGE
SIGNAL (RED)	14	11	50	77.0
(YELLOW)	14	20	5	14.0
(GREEN)	14	12	45	75.6
PERMISSIVE ARROW	16	10	10	16.0
PED. SIGNAL	8	20	100	160.0
CONTROLLER	1	100	100	100.0
UPS	1	25	100	25.0
VIDEO SYSTEM	1	150	100	150.0
BLANK-OUT SIGN	-	25	5	-
FLASHER	-	-	50	-
STREET NAME SIGN	-	120	50	-
LUMINAIRE	-	-	-	-
TOTAL =				617.6

ENERGY COSTS TO:

ILLINOIS DEPARTMENT OF TRANSPORTATION  
DIVISION OF HIGHWAY/DISTRICT 1  
201 WEST CENTER COURT/SCHAUMBURG, ILLINOIS 60196-1096

ENERGY SUPPLY: CONTACT: NEW BUSINESS  
PHONE: NEW PHONE  
COMPANY: COMMONWEALTH EDISON  
ACCOUNT NUMBER: ---

FILE NAME =	USER NAME = bweich
\\cbbelserver\1\cbbel\df\WBK\150077.2\Traf	file\TS08-CAB_Spring.dgn
Default	PLOT SCALE = 48"
	PLOT DATE = 10/17/2017

INTERCONNECT TO NEW YORK STREET

FIBER TERMINATION IN MIS NETWORK HANDHOLE (SEE INTERCONNECT PLAN)

INTERCONNECT TO ATC ENTRANCE

NOTE:

THE TRAFFIC SIGNAL CONTROLLER EQUIPMENT FOR THIS PROJECT SHALL BE "ECONOLITE" TO MATCH THE EXISTING ADJACENT SYSTEM.

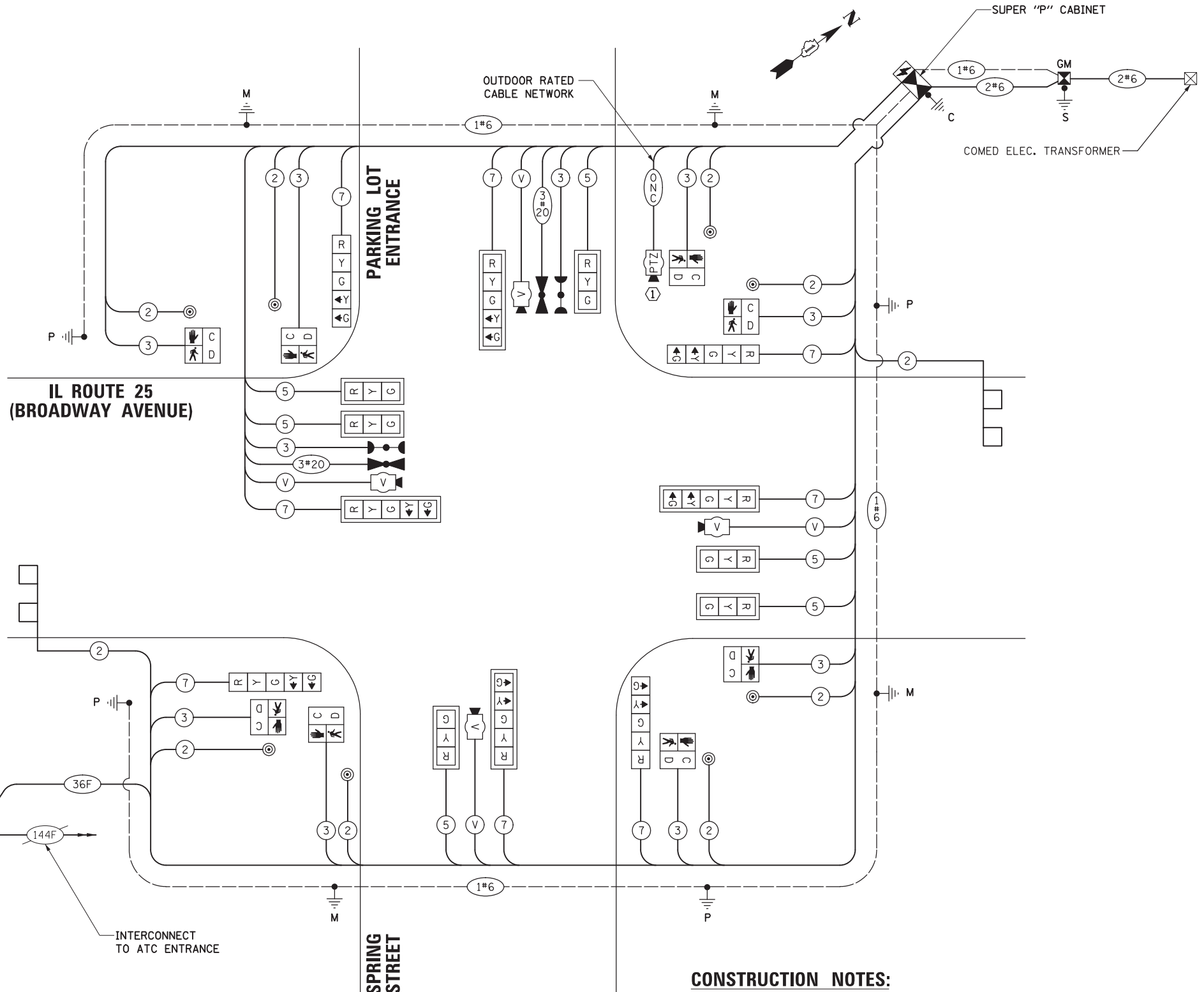

**CABLE PLAN**  
(NOT TO SCALE)

**CONSTRUCTION NOTES:**

- ① THE PTZ CAMERA SHALL BE MOUNTED TO THE END OF THE LUMINAIRE ARM OF THE PROPOSED COMBINATION MAST ARM. (SEE TS SHT NO. 28 FOR DETAILS)
- ② ALL PROPOSED TRAFFIC SIGNAL POSTS AND MAST ARMS SHALL BE POWDER COATED BLACK. SEE SPECIAL PROVISION FOR MORE DETAIL.

TS SHT NO. 16

TS# 816

STATE OF ILLINOIS  
DEPARTMENT OF TRANSPORTATION

CABLE PLAN, PHASE DESIGNATION DIAGRAM  
AND EMERGENCY VEHICLE PREEMPTION SEQUENCE  
IL ROUTE 25 (BROADWAY AVENUE) AND SPRING STREET

F.A.U. RTE.	SECTION	COUNTY	TOTAL SHEETS	SHEET NO.
2503	16-00313-00-MS	KANE	254	123
CONTRACT NO.				
ILLINOIS FED. AID PROJECT				

SCALE: N&S. SHEET OF 254 SHEETS STA. TO STA.

**SIGN PANEL – TYPE 1**

ALL DIMENSIONS ARE IN INCHES UNLESS NOTED OTHERWISE

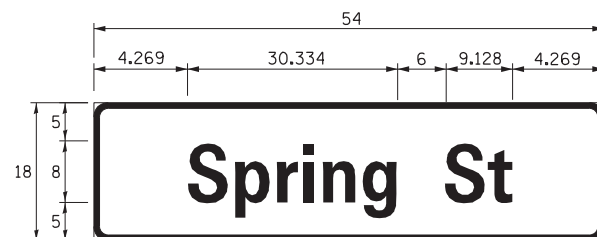

DESIGN SERIES	AREA (SQ FT)	SIGN PANEL TYPE	SHEETING TYPE	QTY. REQUIRED
D	6.75	1	ZZ	2

**SIGN PANEL – TYPE 2**

ALL DIMENSIONS ARE IN INCHES UNLESS NOTED OTHERWISE

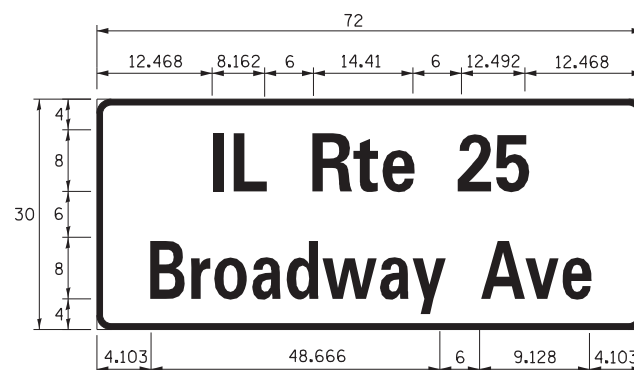

DESIGN SERIES	AREA (SQ FT)	SIGN PANEL TYPE	SHEETING TYPE	QTY. REQUIRED
D	15.0	2	ZZ	2

NOTE: FOR ADDITIONAL DESIGN AND INSTALLATION INFORMATION PLEASE SEE DISTRICT ONE MAST ARM MOUNTED STREET NAME SIGNS DETAIL.

**SCHEDULE OF QUANTITIES**

ITEM	UNIT	QUANTITY
SIGN PANEL - TYPE 1	SQ FT	14
SIGN PANEL - TYPE 2	SQ FT	30
UNDERGROUND CONDUIT, GALVANIZED STEEL, 2" DIA.	FOOT	480
UNDERGROUND CONDUIT, GALVANIZED STEEL, 3" DIA.	FOOT	121
UNDERGROUND CONDUIT, GALVANIZED STEEL, 4" DIA.	FOOT	399
HANDHOLE	EACH	3
DOUBLE HANDHOLE	EACH	2
PAINT NEW TRAFFIC SIGNAL POST	EACH	4
PAINT NEW MAST ARM AND POLE, 40 FOOT AND OVER	EACH	3
PAINT NEW COMBINATION MAST ARM AND POLE, UNDER 40 FOOT	EACH	1
ELECTRC CABLE IN CONDUIT, SIGNAL NO. 14 2C	FOOT	1215
ELECTRC CABLE IN CONDUIT, SIGNAL NO. 14 3C	FOOT	1513
ELECTRC CABLE IN CONDUIT, SIGNAL NO. 14 5C	FOOT	1072
ELECTRC CABLE IN CONDUIT, SIGNAL NO. 14 7C	FOOT	1433
ELECTRC CABLE IN CONDUIT, LEAD-IN, NO. 14 1 PAIR	FOOT	737
ELECTRC CABLE IN CONDUIT, SERVICE, NO. 6 2 C	FOOT	59
ELECTRC CABLE IN CONDUIT, EQUIPMENT GROUNDING CONDUCTOR, NO. 6 1C	FOOT	477
TRAFFIC SIGNAL POST, GALVANIZED STEEL 10 FT.	EACH	1
TRAFFIC SIGNAL POST, GALVANIZED STEEL 16 FT.	EACH	3
STEEL MAST ARM ASSEMBLY AND POLE, 40 FT.	EACH	2
STEEL MAST ARM ASSEMBLY AND POLE, 42 FT.	EACH	1
STEEL COMBINATION MAST ARM ASSEMBLY AND POLE 36 FT.	EACH	1
CONCRETE FOUNDATION, TYPE A	FOOT	20
CONCRETE FOUNDATION, TYPE C	FOOT	4
CONCRETE FOUNDATION, TYPE E 36-INCH DIAMETER	FOOT	50
SIGNAL HEAD, LED, 1-FACE, 3-SECTION, MAST-ARM MOUNTED	EACH	6
SIGNAL HEAD, LED, 1-FACE, 5-SECTION, BRACKET MOUNTED	EACH	4
SIGNAL HEAD, LED, 1-FACE, 5-SECTION, MAST-ARM MOUNTED	EACH	4
PEDESTRIAN SIGNAL HEAD, LED, 1-FACE, BRACKET MOUNTED WITH COUNTDOWN TIMER	EACH	8
TRAFFIC SIGNAL BACKPLATE, LOUVERED, FORMED PLASTIC	EACH	10
INDUCTIVE LOOP DETECTOR	EACH	2
DETECTOR LOOP, TYPE I	FOOT	128
LIGHT DETECTOR	EACH	2
LIGHT DETECTOR AMPLIFIER	EACH	1
PEDESTRIAN PUSH-BUTTON	EACH	8
TEMPORARY TRAFFIC SIGNAL INSTALLATION	EACH	1
REMOVE EXISTING TRAFFIC SIGNAL EQUIPMENT	EACH	1
REMOVE EXISTING HANDHOLE	EACH	5
REMOVE EXISTING DOUBLE HANDHOLE	EACH	1
REMOVE EXISTING CONCRETE FOUNDATION	EACH	7
EMERGENCY VEHICLE PRIORITY SYSTEM LINE SENSOR CABLE, NO. 20 3/C	FOOT	242
VIDEO DETECTION SYSTEM	EACH	1
FULL-ACTUATED CONTROLLER AND TYPE SUPER P CABINET (SPECIAL)	EACH	1
OUTDOOR RATED NETWORK CABLE	FOOT	100
SERVICE INSTALLATION, GROUND MOUNTED, METERED	EACH	1
UNINTERRUPTABLE POWER SUPPLY, SPECIAL	EACH	1
INTERSECTION VIDEO TRAFFIC MONITORING SYSTEM WITH PTZ CAMERA	EACH	1
TEMPORARY TRAFFIC SIGNAL TIMING	EACH	1

TS SHT NO. 17

TS# 816

FILE NAME = \\cbbel\svr1\cbbel\dt\WBK\150077.2\Traf	USER NAME = bweich	DESIGNED - EAJ	REVISED -	<b>STATE OF ILLINOIS DEPARTMENT OF TRANSPORTATION</b>	<b>MAST ARM MOUNTED STREET NAME SIGNS AND SCHEDULE OF QUANTITIES IL ROUTE 25 (BROADWAY AVENUE) AND SPRING STREET</b>	F.A.U. RTE.	SECTION	COUNTY	TOTAL SHEETS	SHEET NO.	
	file\T509-STN_Spring.dgn	DRAWN - FPB	REVISED -			2503	16-00313-00-MS	KANE	254	124	
Default	PLOT SCALE = 48"	CHECKED - TFS	REVISED -			CONTRACT NO.					
	PLOT DATE = 10/17/2017	DATE - 10/17/2017	REVISED -			SCALE: N&S.	SHEET OF 254 SHEETS	STA. TO STA.	ILLINOIS FED. AID PROJECT		



**REMOVAL NOTES:**

THE FOLLOWING ITEMS SHALL BE REMOVED BY THE CONTRACTOR AND SHALL BE DISPOSED OF BY THEM OUTSIDE THE RIGHT-OF-WAY AT THEIR EXPENSE. THE SALVAGE VALUE OF THE REMOVED EQUIPMENT SHALL BE REFLECTED IN THE CONTRACT BID PRICE.

- 2 EACH STEEL MAST ARM ASSEMBLY AND POLE
- 4 EACH TRAFFIC SIGNAL POST
- 7 EACH 3-SECTION SIGNAL HEAD
- 5 EACH 4-SECTION SIGNAL HEAD
- 4 EACH 5-SECTION SIGNAL HEAD
- 6 EACH PEDESTRIAN SIGNAL HEAD
- 4 EACH PEDESTRIAN PUSH-BUTTON
- 1 EACH SERVICE INSTALLATION
- 6 EACH TRAFFIC SIGNAL BACKPLATE
- 1 EACH TRAFFIC SIGNAL CABINET

THE FOLLOWING EXISTING TRAFFIC SIGNAL EQUIPMENT SHALL BE REMOVED BY THE CONTRACTOR AND SHALL REMAIN THE PROPERTY OF THE AGENCY LISTED BELOW. THE CONTRACTOR SHALL SAFELY STORE AND ARRANGE FOR THE PICK UP OF ALL THE EQUIPMENT TO BE RETURNED TO THE LISTED AGENCY.

NAME OF AGENCY: CITY OF AURORA  
DEPARTMENT: ELECTRICAL DEPARTMENT

- 2 EACH CONFIRMATION BEACON
- 2 EACH LIGHT DETECTOR
- 2 EACH RADIO COMMUNICATION ANTENNA

NAME OF AGENCY: ILLINOIS DEPARTMENT OF TRANSPORTATION

- 1 EACH TRAFFIC SIGNAL CONTROLLER
- 1 EACH UPS INSTALLATION

**CONSTRUCTION NOTE:**

- ① THE CONTRACTOR SHALL PROVIDE TRAFFIC CONTROL PER IDOT HIGHWAY STANDARD 701701 DURING THE REMOVAL OF THE TRAFFIC SIGNAL INSTALLATION. THIS WORK SHALL BE INCLUDED IN THE COST OF THE PAY ITEM: TRAFFIC CONTROL AND PROTECTION, SPECIAL.

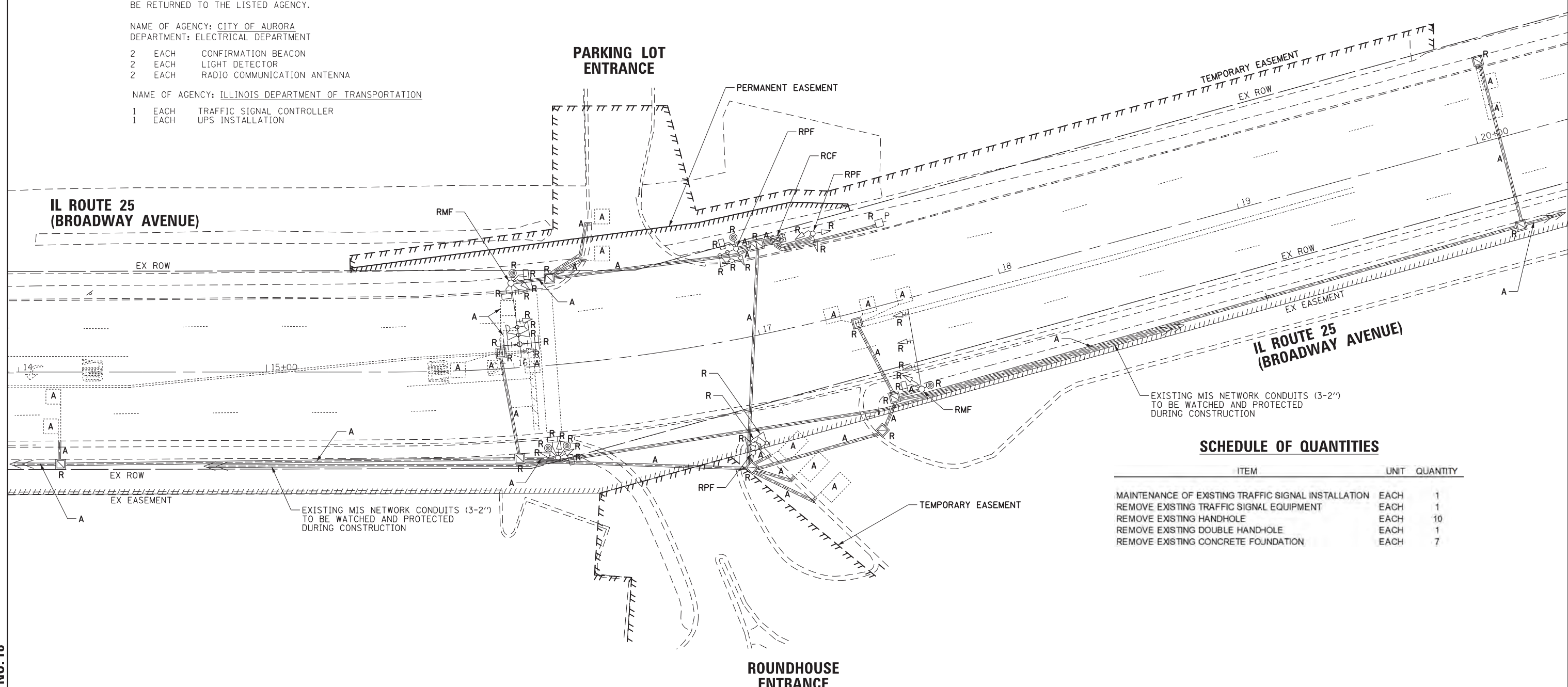
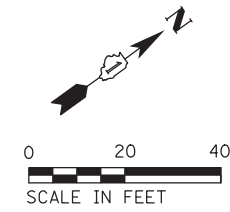

**SCHEDULE OF QUANTITIES**

ITEM	UNIT	QUANTITY
MAINTENANCE OF EXISTING TRAFFIC SIGNAL INSTALLATION	EACH	1
REMOVE EXISTING TRAFFIC SIGNAL EQUIPMENT	EACH	1
REMOVE EXISTING HANDHOLE	EACH	10
REMOVE EXISTING DOUBLE HAND-HOLE	EACH	1
REMOVE EXISTING CONCRETE FOUNDATION	EACH	7

TS SHT NO. 18

FILE NAME = \\cbbelserver\cbbel\df\WBK\150077.2\Traffic\TS10-REM_Roundhouse.dgn	USER NAME = bweilch	DESIGNED - EAJ	REVISED -	<b>STATE OF ILLINOIS DEPARTMENT OF TRANSPORTATION</b>	<b>EXISTING TRAFFIC SIGNAL EQUIPMENT REMOVAL PLAN IL ROUTE 25 (BROADWAY AVENUE) AND ROUNDHOUSE ENTRANCE</b>	F.A.U. RTE. 2503	SECTION 16-00313-00-MS	COUNTY KANE	TOTAL SHEETS 254	SHEET NO. 125		
Default	PLOT SCALE = 48"	CHECKED - TFS	REVISED -			SCALE: 48"	SHEET OF 254 SHEETS	STA. TO STA.	CONTRACT NO.			
	PLOT DATE = 10/17/2017	DATE - 10/17/2017	REVISED -			ILLINOIS FED. AID PROJECT						
TS# 791												

**NOTE:**

1. EACH DETECTOR LOOP SHALL HAVE ITS OWN 1" COILABLE NON-METALLIC CONDUIT BETWEEN THE EDGE OF PAVEMENT AND THE ADJACENT HANDHOLE AS SHOWN ON THE PLANS AND AS STATED IN THE TRAFFIC SIGNAL SPECIFICATIONS.

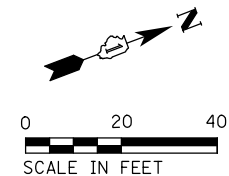

**IL ROUTE 25  
(BROADWAY AVENUE)**

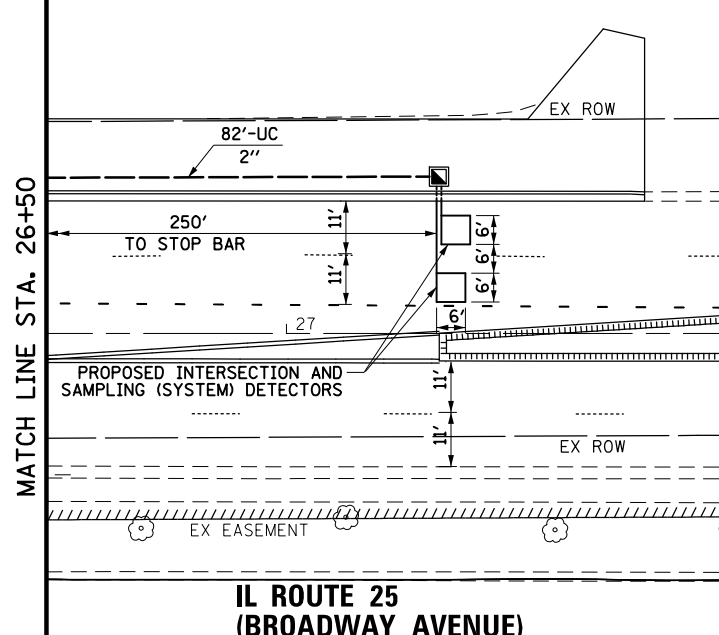
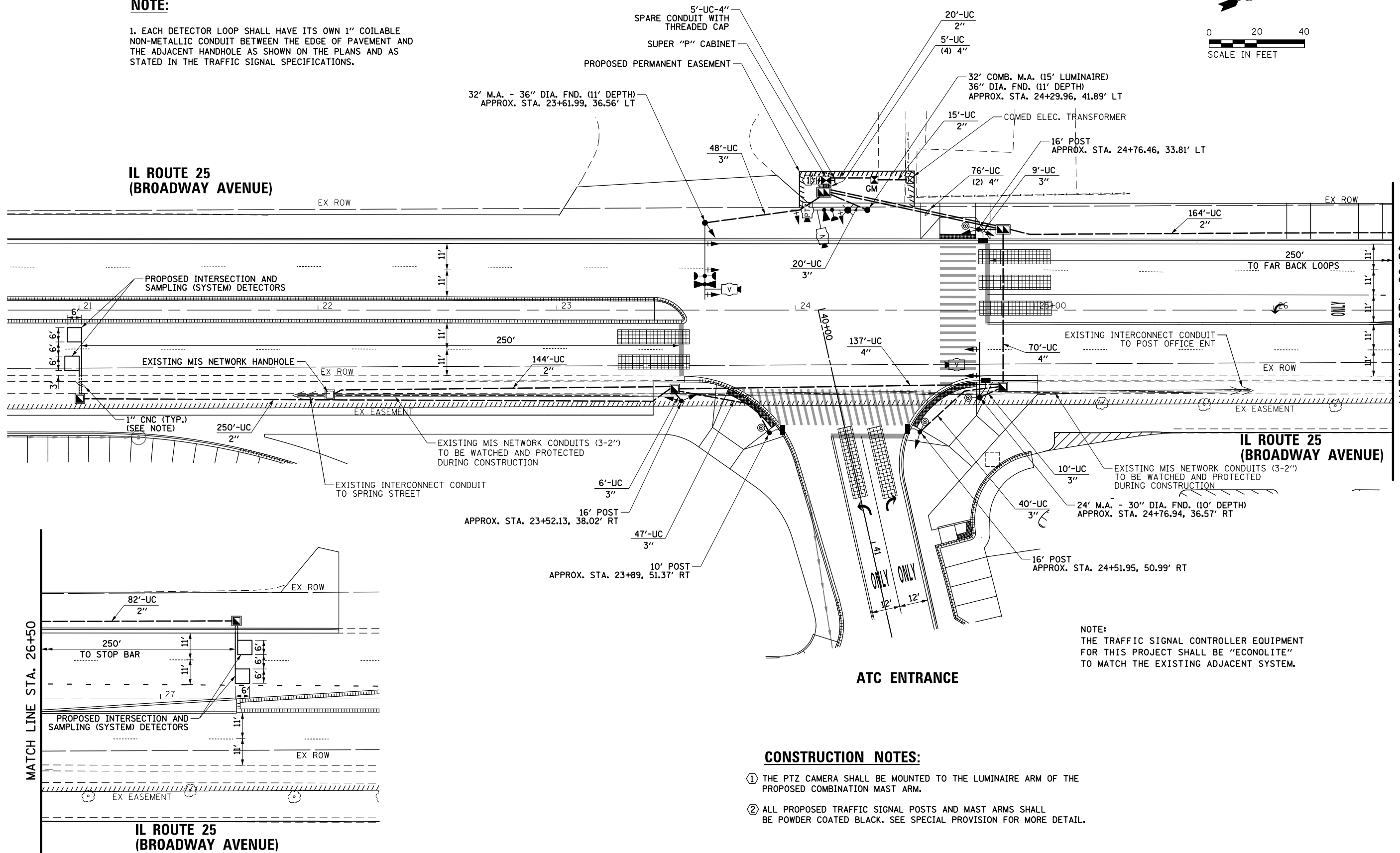

NOTE:  
THE TRAFFIC SIGNAL CONTROLLER EQUIPMENT FOR THIS PROJECT SHALL BE "ECONOLITE" TO MATCH THE EXISTING ADJACENT SYSTEM.

**CONSTRUCTION NOTES:**

- ① THE PTZ CAMERA SHALL BE MOUNTED TO THE LUMINAIRE ARM OF THE PROPOSED COMBINATION MAST ARM.
- ② ALL PROPOSED TRAFFIC SIGNAL POSTS AND MAST ARMS SHALL BE POWDER COATED BLACK. SEE SPECIAL PROVISION FOR MORE DETAIL.

TS SHT NO. 19

FILE NAME = \\cbbel\svr1\cbbel\df\WBK\150077.2\Traffic\TS11-TSD.ATC.dgn	USER NAME = bweich	DESIGNED - EAJ	REVISED -	<b>STATE OF ILLINOIS DEPARTMENT OF TRANSPORTATION</b>	<b>TRAFFIC SIGNAL INSTALLATION PLAN IL ROUTE 25 (BROADWAY AVENUE) AND ATC ENTRANCE</b>	F.A.U. RTE.	SECTION	COUNTY	TOTAL SHEETS	SHEET NO.	
Default	PLOT SCALE = 48"	DRAWN - FPB	REVISED -			2503	16-00313-00-MS	KANE	254	126	
	PLOT DATE = 12/4/2017	CHECKED - TFS	REVISED -			CONTRACT NO.					
		DATE - 12/4/2017	REVISED -			ILLINOIS FED. AID PROJECT					

TS#

**PROPOSED CONTROLLER SEQUENCE**

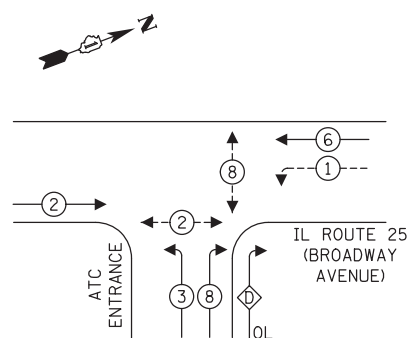

- LEGEND:**
- ← ⊛ → PROTECTED PHASE
  - ← ⊛ - - - ⊛ → PROTECTED/PERMITTED PHASE
  - ← ⊛ → PEDESTRIAN PHASE
  - ← ⊛ OL → OVERLAP

**RIGHT TURN OVERLAP PHASE DESIGNATION:**

OVERLAP LETTER	PERMISSIVE PHASE	PROTECTED PHASE
D	8	1

**PROPOSED EMERGENCY VEHICLE PREEMPTION SEQUENCE**

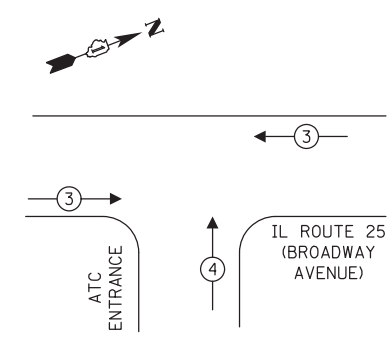

**TRAFFIC SIGNAL ELECTRICAL SERVICE REQUIREMENTS**

TYPE	NO. OF LAMPS	LED WATTAGE	% OPERATION	TOTAL WATTAGE
SIGNAL (RED)	13	11	50	71.5
(YELLOW)	13	20	5	13.0
(GREEN)	13	12	45	70.2
PERMISSIVE ARROW	8	10	10	8.0
PED. SIGNAL	4	20	100	80.0
CONTROLLER	1	100	100	100.0
UPS	1	25	100	25.0
VIDEO SYSTEM	1	150	100	150.0
BLANK-OUT SIGN	-	25	5	-
FLASHER	-	-	50	-
STREET NAME SIGN	-	120	50	-
LUMINAIRE	-	-	-	-
TOTAL =				517.7

ENERGY COSTS TO:  
ILLINOIS DEPARTMENT OF TRANSPORTATION  
DIVISION OF HIGHWAY/DISTRICT 1  
201 WEST CENTER COURT/SCHAUMBURG, ILLINOIS 60196-1096  
ENERGY SUPPLY: CONTACT: NEW BUSINESS  
PHONE: NEW PHONE  
COMPANY: COMMONWEALTH EDISON  
ACCOUNT NUMBER: ---

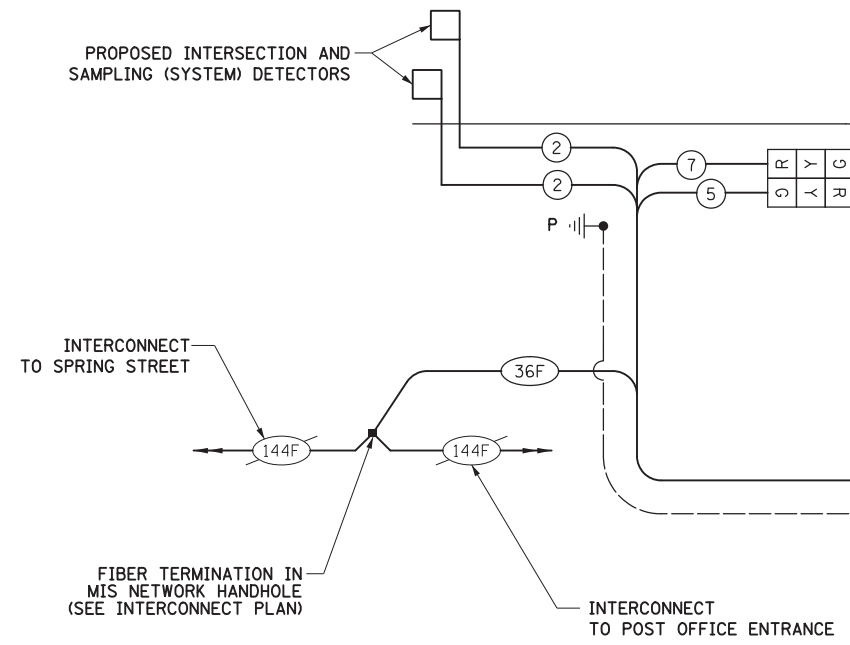

**NOTE:**  
THE TRAFFIC SIGNAL CONTROLLER EQUIPMENT FOR THIS PROJECT SHALL BE "ECONOLITE" TO MATCH THE EXISTING ADJACENT SYSTEM.

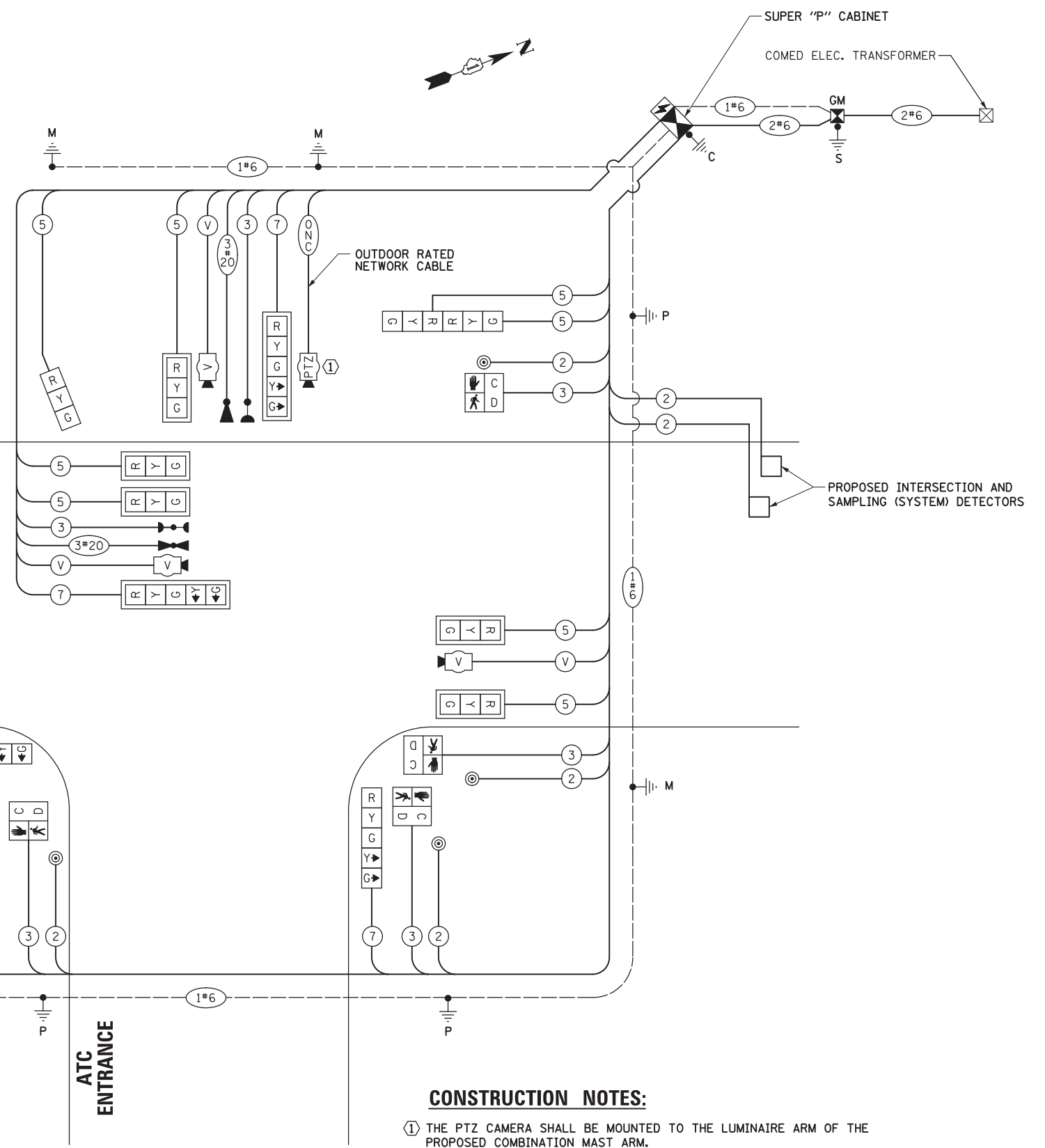

**CABLE PLAN**  
(NOT TO SCALE)

**CONSTRUCTION NOTES:**

- ① THE PTZ CAMERA SHALL BE MOUNTED TO THE LUMINAIRE ARM OF THE PROPOSED COMBINATION MAST ARM.
- ② ALL PROPOSED TRAFFIC SIGNAL POSTS AND MAST ARMS SHALL BE POWDER COATED BLACK. SEE SPECIAL PROVISION FOR MORE DETAIL.

TS SHT NO. 20

FILE NAME =	USER NAME = bweich
\\cbbelserver\ncbbel\df\WBK\150077.2\Traffic\TS12-CAB_ATC.dgn	
Default	PLOT DATE = 10/17/2017

DESIGNED - EAJ	REVISED -
DRAWN - FPB	REVISED -
CHECKED - TFS	REVISED -
DATE - 10/17/2017	REVISED -

**STATE OF ILLINOIS**  
**DEPARTMENT OF TRANSPORTATION**

**CABLE PLAN, PHASE DESIGNATION DIAGRAM, AND EMERGENCY VEHICLE PREEMPTION SEQUENCE**  
**IL ROUTE 25 (BROADWAY AVENUE) AND ATC ENTRANCE**

F.A.U. RTE.	SECTION	COUNTY	TOTAL SHEETS	SHEET NO.
2503	16-00313-00-MS	KANE	254	127
CONTRACT NO.				
ILLINOIS FED. AID PROJECT				

TS# \_\_\_\_\_

**SIGN PANEL – TYPE 2**

ALL DIMENSIONS ARE IN INCHES UNLESS NOTED OTHERWISE

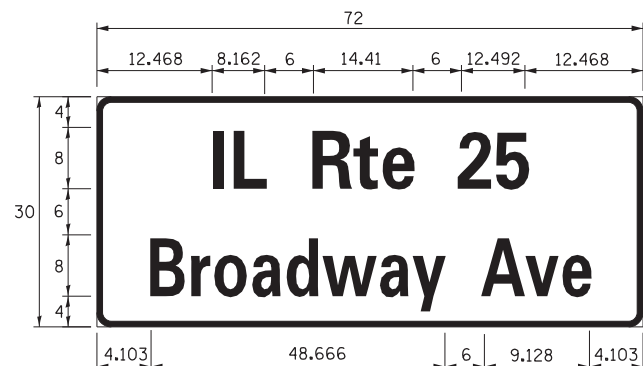

DESIGN SERIES	AREA (SQ FT)	SIGN PANEL TYPE	SHEETING TYPE	QTY. REQUIRED
D	15.0	2	ZZ	2

NOTE: FOR ADDITIONAL DESIGN AND INSTALLATION INFORMATION PLEASE SEE DISTRICT ONE MAST ARM MOUNTED STREET NAME SIGNS DETAIL.

**SCHEDULE OF QUANTITIES**

ITEM	UNIT	QUANTITY
SIGN PANEL - TYPE 2	SQ FT	14
UNDERGROUND CONDUIT, GALVANIZED STEEL, 2" DIA.	FOOT	449
UNDERGROUND CONDUIT, GALVANIZED STEEL, 3" DIA.	FOOT	160
UNDERGROUND CONDUIT, GALVANIZED STEEL, 4" DIA.	FOOT	384
HANDHOLE	EACH	4
DOUBLE HANDHOLE	EACH	2
MAINTENANCE OF EXISTING TRAFFIC SIGNAL INSTALLATION	EACH	1
PAINT NEW TRAFFIC SIGNAL POST	EACH	4
PAINT NEW MAST ARM AND POLE, UNDER 40 FOOT	EACH	2
PAINT NEW COMBINATION MAST ARM AND POLE, UNDER 40 FOOT	EACH	1
ELECTRIC CABLE IN CONDUIT, SIGNAL NO. 14 2C	FOOT	969
ELECTRIC CABLE IN CONDUIT, SIGNAL NO. 14 3C	FOOT	1150
ELECTRIC CABLE IN CONDUIT, SIGNAL NO. 14 5C	FOOT	1528
ELECTRIC CABLE IN CONDUIT, SIGNAL NO. 14 7C	FOOT	827
ELECTRIC CABLE IN CONDUIT, LEAD-IN, NO. 14 1 PAIR	FOOT	1880
ELECTRIC CABLE IN CONDUIT, SERVICE, NO. 6 2 C	FOOT	53
ELECTRIC CABLE IN CONDUIT, EQUIPMENT GROUNDING CONDUCTOR, NO. 6 1C	FOOT	560
TRAFFIC SIGNAL POST, GALVANIZED STEEL 10 FT.	EACH	1
TRAFFIC SIGNAL POST, GALVANIZED STEEL 16 FT.	EACH	3
STEEL MAST ARM ASSEMBLY AND POLE, 24 FT.	EACH	1
STEEL MAST ARM ASSEMBLY AND POLE, 32 FT.	EACH	1
STEEL COMBINATION MAST ARM ASSEMBLY AND POLE 32 FT.	EACH	1
CONCRETE FOUNDATION, TYPE A	FOOT	20
CONCRETE FOUNDATION, TYPE C	FOOT	4
CONCRETE FOUNDATION, TYPE E 30-INCH DIAMETER	FOOT	10
CONCRETE FOUNDATION, TYPE E 36-INCH DIAMETER	FOOT	22
SIGNAL HEAD, LED, 1-FACE, 3-SECTION, MAST-ARM MOUNTED	EACH	5
SIGNAL HEAD, LED, 1-FACE, 3-SECTION, BRACKET MOUNTED	EACH	4
SIGNAL HEAD, LED, 1-FACE, 5-SECTION, BRACKET MOUNTED	EACH	2
SIGNAL HEAD, LED, 1-FACE, 5-SECTION, MAST-ARM MOUNTED	EACH	2
PEDESTRIAN SIGNAL HEAD, LED, 1-FACE, BRACKET MOUNTED WITH COUNTDOWN TIMER	EACH	4
TRAFFIC SIGNAL BACKPLATE, LOUVERED, FORMED PLASTIC	EACH	7
INDUCTIVE LOOP DETECTOR	EACH	4
DETECTOR LOOP, TYPE I	FOOT	130
LIGHT DETECTOR	EACH	2
LIGHT DETECTOR AMPLIFIER	EACH	1
PEDESTRIAN PUSH-BUTTON	EACH	4
EMERGENCY VEHICLE PRIORITY SYSTEM LINE SENSOR CABLE, NO. 20 3/C	FOOT	203
VIDEO DETECTION SYSTEM	EACH	1
FULL-ACTUATED CONTROLLER AND TYPE SUPER P CABINET (SPECIAL)	EACH	1
OUTDOOR RATED NETWORK CABLE	FOOT	108
SERVICE INSTALLATION, GROUND MOUNTED, METERED	EACH	1
UNINTERRUPTABLE POWER SUPPLY, SPECIAL	EACH	1
INTERSECTION VIDEO TRAFFIC MONITORING SYSTEM WITH PTZ CAMERA	EACH	1

TS SHT NO. 21

TS# \_\_\_\_\_

FILE NAME =	USER NAME = bweich	DESIGNED - EAJ	REVISED -	<b>STATE OF ILLINOIS DEPARTMENT OF TRANSPORTATION</b>	<b>MAST ARM MOUNTED STREET NAME SIGNS AND SCHEDULE OF QUANTITIES IL ROUTE 25 (BROADWAY AVENUE) AND ATC ENTRANCE</b>	F.A.U. RTE.	SECTION	COUNTY	TOTAL SHEETS	SHEET NO.	
\\cbbelserver\cbbel\df\WBK\150077.2\Traf	file\TS13-STN.ATC.dgn	DRAWN - FPB	REVISED -			2503	16-00313-00-MS	KANE	254	128	
Default	PLOT SCALE = 48"	CHECKED - TFS	REVISED -			CONTRACT NO.					
	PLOT DATE = 10/17/2017	DATE - 10/17/2017	REVISED -			SCALE: N.T.S.	SHEET OF 254 SHEETS	STA. TO STA.	ILLINOIS FED. AID PROJECT		

**REMOVAL NOTES:**

THE FOLLOWING ITEMS SHALL BE REMOVED BY THE CONTRACTOR AND SHALL BE DISPOSED OF BY THEM OUTSIDE THE RIGHT-OF-WAY AT THEIR EXPENSE. THE SALVAGE VALUE OF THE REMOVED EQUIPMENT SHALL BE REFLECTED IN THE CONTRACT BID PRICE.

- 3 EACH PEDESTRIAN PUSH-BUTTON

THE FOLLOWING EXISTING TRAFFIC SIGNAL EQUIPMENT SHALL BE REMOVED BY THE CONTRACTOR AND SHALL REMAIN THE PROPERTY OF THE AGENCY LISTED BELOW. THE CONTRACTOR SHALL SAFELY STORE AND ARRANGE FOR THE PICK UP OF ALL THE EQUIPMENT TO BE RETURNED TO THE LISTED AGENCY.

NAME OF AGENCY: CITY OF AURORA  
DEPARTMENT: ELECTRICAL DEPARTMENT

- 1 EACH WIRELESS INTERCONNECT INSTALLATION

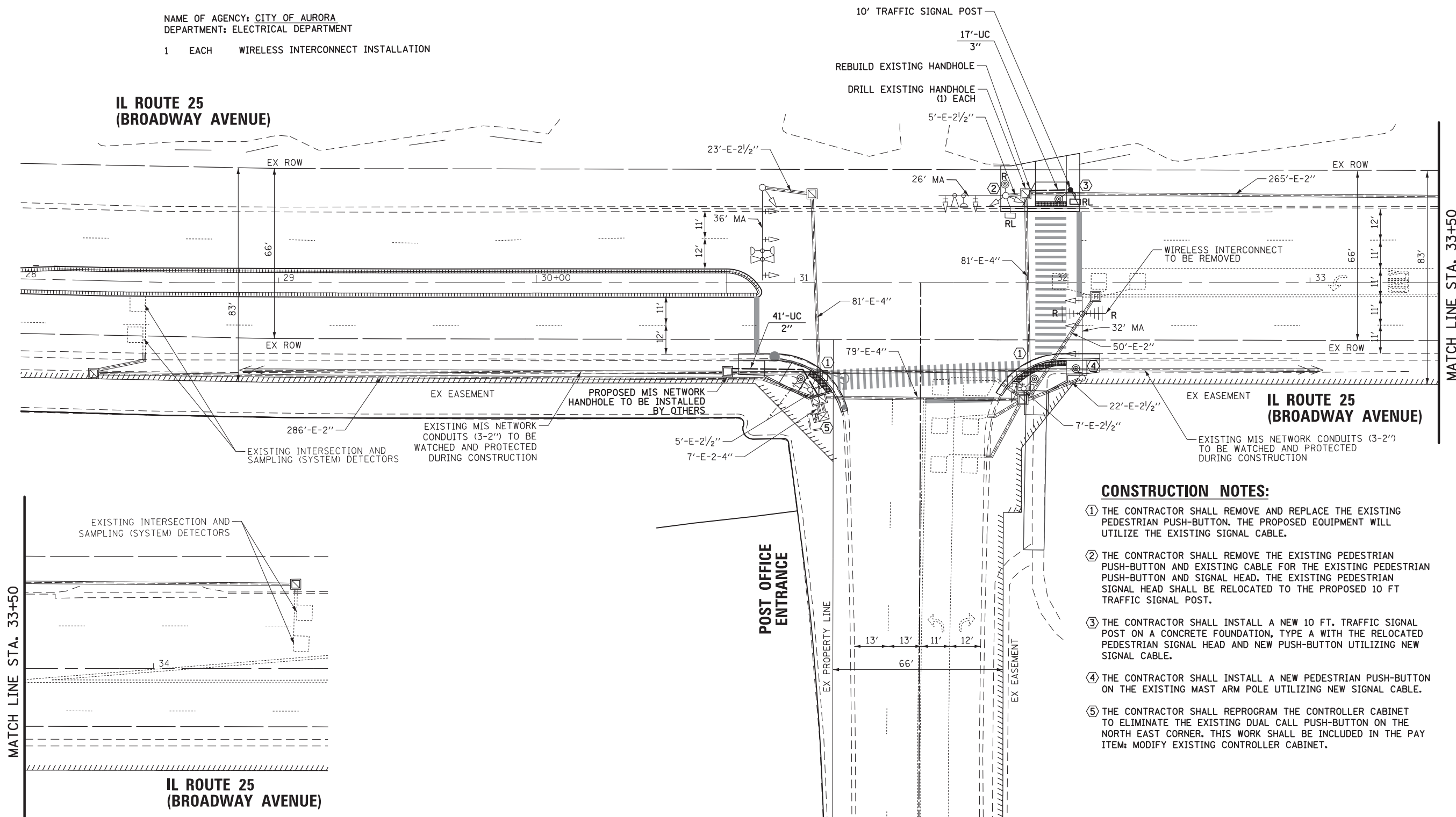
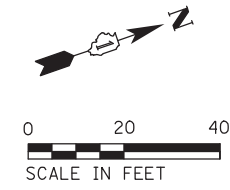

**CONSTRUCTION NOTES:**

- ① THE CONTRACTOR SHALL REMOVE AND REPLACE THE EXISTING PEDESTRIAN PUSH-BUTTON. THE PROPOSED EQUIPMENT WILL UTILIZE THE EXISTING SIGNAL CABLE.
- ② THE CONTRACTOR SHALL REMOVE THE EXISTING PEDESTRIAN PUSH-BUTTON AND EXISTING CABLE FOR THE EXISTING PEDESTRIAN PUSH-BUTTON AND SIGNAL HEAD. THE EXISTING PEDESTRIAN SIGNAL HEAD SHALL BE RELOCATED TO THE PROPOSED 10 FT TRAFFIC SIGNAL POST.
- ③ THE CONTRACTOR SHALL INSTALL A NEW 10 FT. TRAFFIC SIGNAL POST ON A CONCRETE FOUNDATION, TYPE A WITH THE RELOCATED PEDESTRIAN SIGNAL HEAD AND NEW PUSH-BUTTON UTILIZING NEW SIGNAL CABLE.
- ④ THE CONTRACTOR SHALL INSTALL A NEW PEDESTRIAN PUSH-BUTTON ON THE EXISTING MAST ARM POLE UTILIZING NEW SIGNAL CABLE.
- ⑤ THE CONTRACTOR SHALL REPROGRAM THE CONTROLLER CABINET TO ELIMINATE THE EXISTING DUAL CALL PUSH-BUTTON ON THE NORTH EAST CORNER. THIS WORK SHALL BE INCLUDED IN THE PAY ITEM: MODIFY EXISTING CONTROLLER CABINET.

TS SHT NO. 22

MATCH LINE STA. 33+50

MATCH LINE STA. 33+50

STATE OF ILLINOIS  
DEPARTMENT OF TRANSPORTATION

TRAFFIC SIGNAL MODIFICATION PLAN  
IL ROUTE 25 (BROADWAY AVENUE) AND POST OFFICE ENTRANCE

TS# 790

FILE NAME = \\cbbelrvr\ncbbelr\WBK\150077.2\Traffic\TS14-MOD_Post Office.dgn	USER NAME = bweich	DESIGNED - EAJ	REVISED -	SCALE: 40' SHEET OF 254 SHEETS STA. TO STA.	F.A.U. RTE. 2503	SECTION 16-00313-00-MS	COUNTY KANE	TOTAL SHEETS 254	SHEET NO. 129	
Default	PLOT SCALE = 40'	CHECKED - TFS	REVISED -		CONTRACT NO.					
	PLOT DATE = 10/17/2017	DATE - 10/17/2017	REVISED -		ILLINOIS FED. AID PROJECT					

**PROPOSED CONTROLLER SEQUENCE**

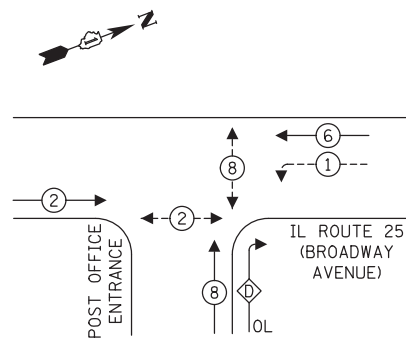

**LEGEND:**

- ← ⊛ → PROTECTED PHASE
- ← ⊛ --- PROTECTED/PERMITTED PHASE
- ← ⊛ → PEDESTRIAN PHASE
- ← ⊛ OL OVERLAP

**RIGHT TURN OVERLAP**

**PHASE DESIGNATION:**

OVERLAP LETTER	PERMISSIVE PHASE	PROTECTED PHASE
D	= 8	+ 1

**PROPOSED EMERGENCY VEHICLE PREEMPTION SEQUENCE**

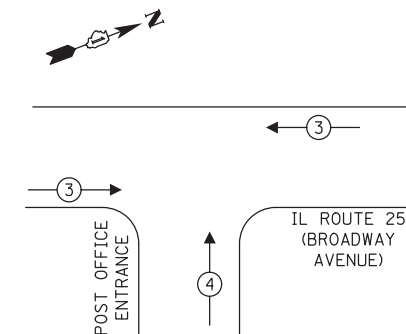

**TRAFFIC SIGNAL ELECTRICAL SERVICE REQUIREMENTS**

TYPE	NO. OF LAMPS	LED WATTAGE	% OPERATION	TOTAL WATTAGE
SIGNAL (RED)	14	11	50	77.0
(YELLOW)	14	20	5	14.0
(GREEN)	14	12	45	75.6
PERMISSIVE ARROW	8	10	10	8.0
PED. SIGNAL	4	20	100	80.0
CONTROLLER	1	100	100	100.0
UPS	1	25	100	25.0
VIDEO SYSTEM	-	150	100	-
BLANK-OUT SIGN	-	25	5	-
FLASHER	-	-	50	-
STREET NAME SIGN	-	120	50	-
LUMINAIRE	-	-	-	-
TOTAL =				379.6

ENERGY COSTS TO:

ILLINOIS DEPARTMENT OF TRANSPORTATION  
DIVISION OF HIGHWAY/DISTRICT 1  
201 WEST CENTER COURT/SCHAUMBURG, ILLINOIS 60196-1096

ENERGY SUPPLY: CONTACT: NEW BUSINESS  
PHONE: NEW PHONE  
COMPANY: COMMONWEALTH EDISON  
ACCOUNT NUMBER: ---

**CONSTRUCTION NOTES:**

- ① THE CONTRACTOR SHALL REMOVE AND REPLACE THE EXISTING PEDESTRIAN PUSH-BUTTON. THE PROPOSED EQUIPMENT WILL UTILIZE THE EXISTING SIGNAL CABLE.
- ② THE CONTRACTOR SHALL REMOVE THE EXISTING PEDESTRIAN PUSH-BUTTON AND EXISTING CABLE FOR THE EXISTING PEDESTRIAN SIGNAL HEAD AND SIGNAL HEAD. THE EXISTING PEDESTRIAN SIGNAL HEAD SHALL BE RELOCATED TO THE PROPOSED 10 FT TRAFFIC SIGNAL POST.
- ③ THE CONTRACTOR SHALL INSTALL A NEW 10 FT. TRAFFIC SIGNAL POST ON A CONCRETE FOUNDATION, TYPE A WITH THE RELOCATED PEDESTRIAN SIGNAL HEAD AND NEW PUSH-BUTTON UTILIZING NEW SIGNAL CABLE.
- ④ THE CONTRACTOR SHALL INSTALL A NEW PEDESTRIAN PUSH-BUTTON ON THE EXISTING MAST ARM POLE UTILIZING NEW SIGNAL CABLE.
- ⑤ THE CONTRACTOR SHALL REPROGRAM THE CONTROLLER CABINET TO ELIMINATE THE EXISTING DUAL CALL PUSH-BUTTON ON THE NORTH EAST CORNER. THIS WORK SHALL BE INCLUDED IN THE PAY ITEM: MODIFY EXISTING CONTROLLER CABINET.

**IL ROUTE 25 (BROADWAY STREET)**

**IL ROUTE 25 (BROADWAY AVENUE)**

**POST OFFICE ENTRANCE**

**CABLE PLAN (NOT TO SCALE)**

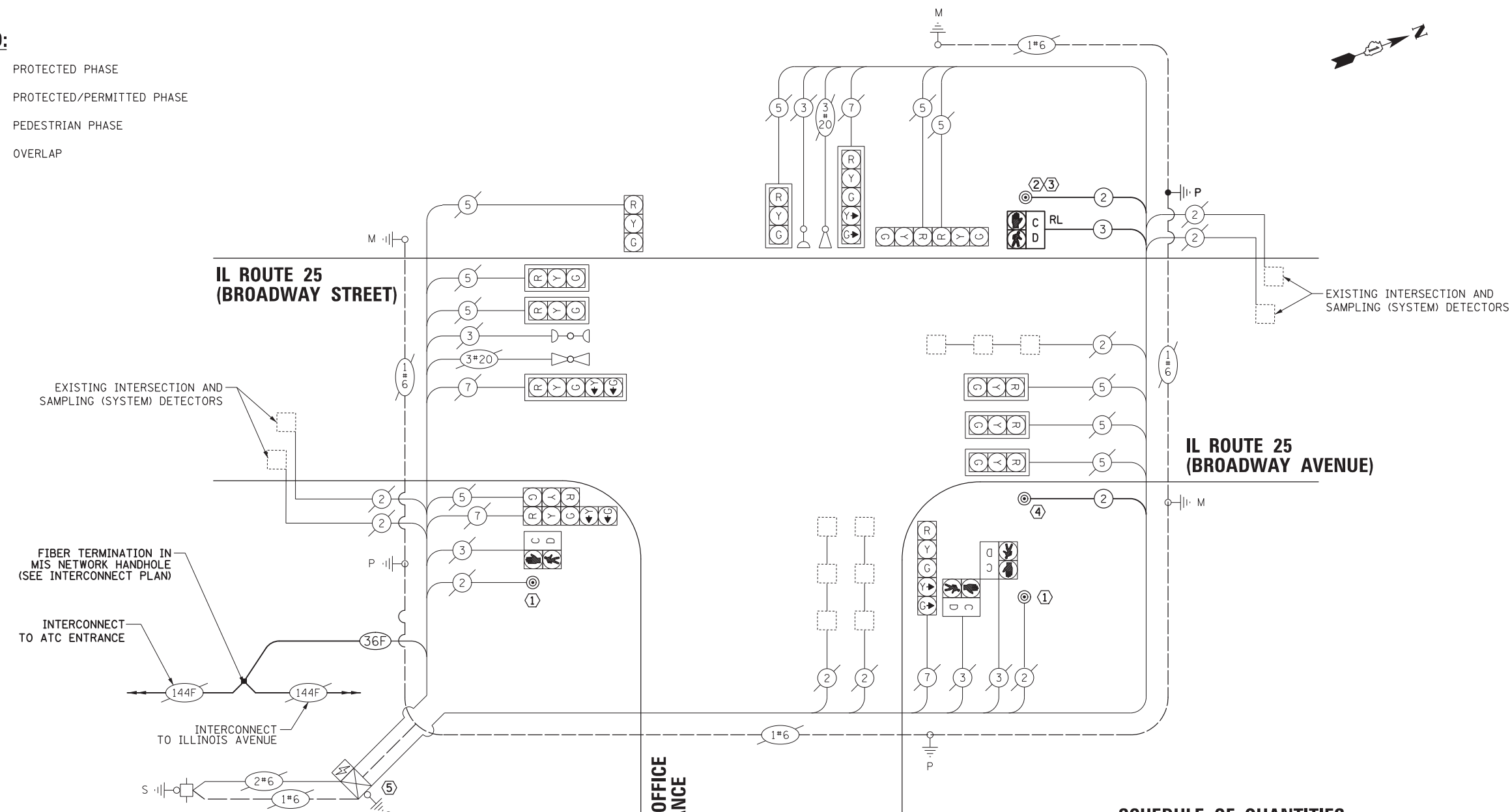

**SCHEDULE OF QUANTITIES**

ITEM	UNIT	QUANTITY
UNDERGROUND CONDUIT, GALVANIZED STEEL, 3" DIA.	FOOT	17
MAINTENANCE OF EXISTING TRAFFIC SIGNAL INSTALLATION	EACH	1
PAINT NEW TRAFFIC SIGNAL POST	EACH	1
ELECTRIC CABLE IN CONDUIT, SIGNA. NO. 14 2C	FOOT	368
ELECTRIC CABLE IN CONDUIT, SIGNA. NO. 14 3C	FOOT	232
ELECTRIC CABLE IN CONDUIT, EQUIPMENT GROUNDING CONDUCTOR, NO. 6 1C	FOOT	27
TRAFFIC SIGNAL POST, GALVANIZED STEEL 10 FT.	EACH	1
CONCRETE FOUNDATION, TYPE A	FOOT	4
DRILL EXISTING HANDHOLE	EACH	1
PEDESTRIAN PUSH-BUTTON	EACH	4
RELOCATE EXISTING PEDESTRIAN SIGNAL HEAD	EACH	1
MODIFY EXISTING CONTROLLER CABINET	EACH	1
REMOVE ELECTRIC CABLE FROM CONDUIT	FOOT	432
REBUILD EXISTING HANDHOLE	EACH	1
REMOVE RADIO INTERCONNECT	EACH	1
REMOVE PEDESTRIAN PUSH-BUTTON	EACH	3
TEMPORARY TRAFFIC SIGNAL TIMING	EACH	1

TS SHT NO. 23

FILE NAME = \\cbbel\svr\1\cbbel\df\WBK\150077.2\Traf...  
USER NAME = bweich  
DRAWN - FPB  
CHECKED - TFS  
DATE - 10/17/2017

DESIGNED - EAJ  
DRAWN - FPB  
CHECKED - TFS  
DATE - 10/17/2017

STATE OF ILLINOIS  
DEPARTMENT OF TRANSPORTATION

**CABLE PLAN, PHASE DESIGNATION DIAGRAM, AND EMERGENCY VEHICLE PREEMPTION SEQUENCE**  
**IL ROUTE 25 (BROADWAY AVENUE) AND POST OFFICE ENTRANCE**

F.A.U. RTE. SECTION COUNTY TOTAL SHEETS SHEET NO.  
2503 16-00313-00-MS KANE 254 130  
CONTRACT NO.  
ILLINOIS FED. AID PROJECT

TS# 790

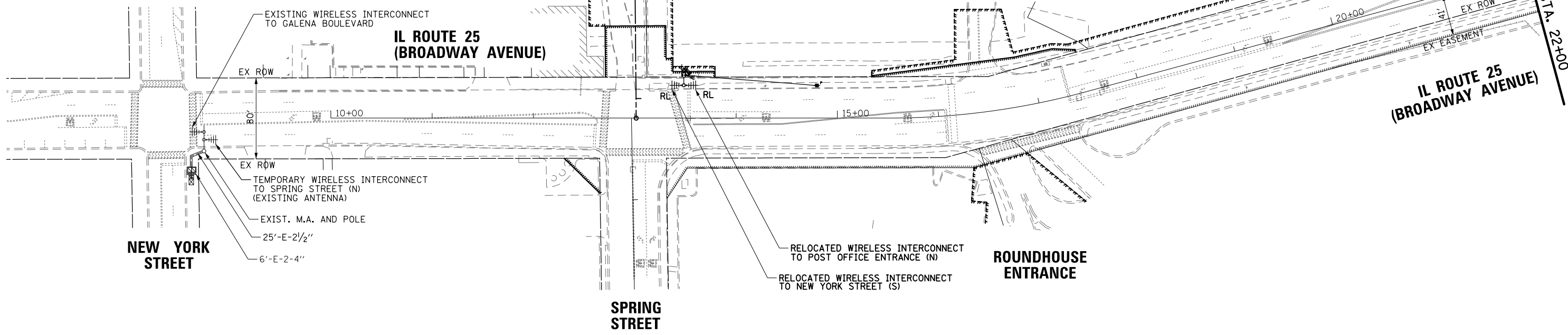
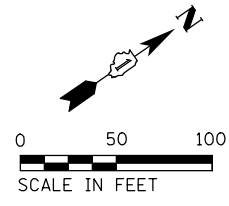

NOTE:  
 THE TRAFFIC SIGNAL CONTROLLER EQUIPMENT  
 FOR THIS PROJECT SHALL BE "ECONOLITE"  
 TO MATCH THE EXISTING ADJACENT SYSTEM.

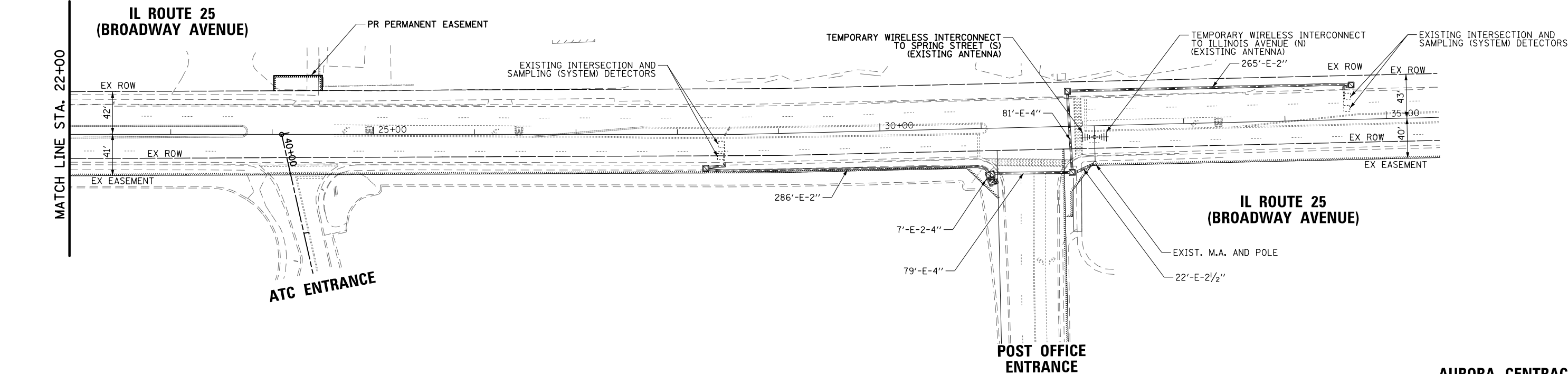

TS SHT NO. 24

FILE NAME = \\cbbel\svr1\cbbeldf\WBK\150077.2\Traffic\TS16-INT.Temporary.dgn	USER NAME = bweich	DESIGNED - EAJ	REVISED -	<b>STATE OF ILLINOIS DEPARTMENT OF TRANSPORTATION</b>	<b>TEMPORARY INTERCONNECT PLAN IL ROUTE 25 (BROADWAY AVENUE) FROM NEW YORK STREET TO POST OFFICE ENTRANCE</b>	F.A.U. RTE. = 2503	SECTION = 16-00313-00-MS	COUNTY = KANE	TOTAL SHEETS = 254	SHEET NO. = 131
	PLOT SCALE = 100'	CHECKED - TFS	REVISED -			SCALE: 100'	SHEET OF 254 SHEETS	STA. TO STA.	CONTRACT NO. ILLINOIS FED. AID PROJECT	
Default	PLOT DATE = 12/4/2017	DATE = 12/4/2017	REVISED -							

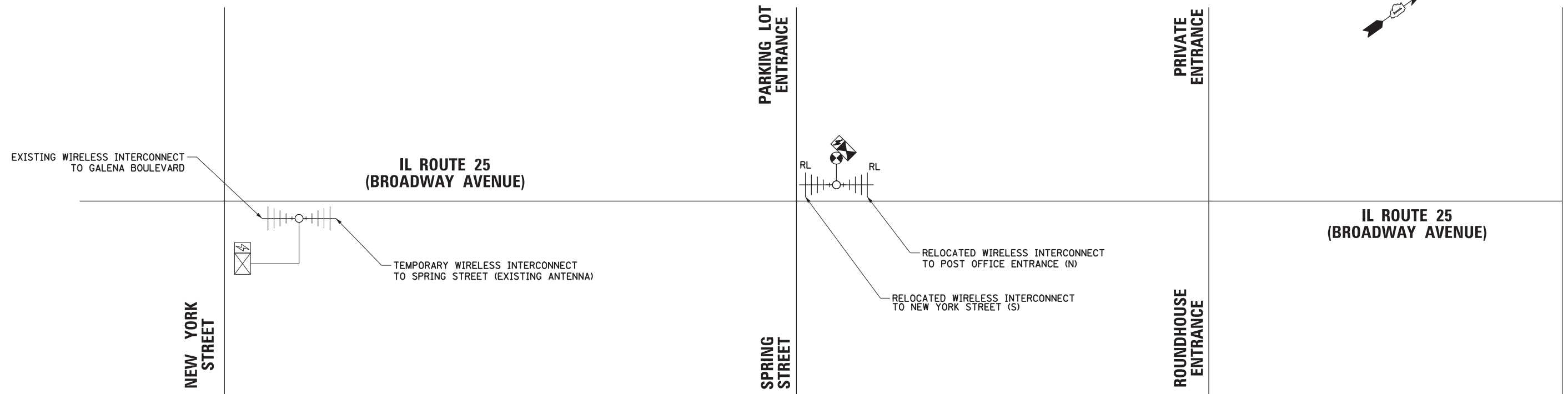
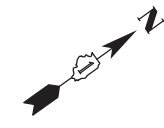

NOTE:  
 THE TRAFFIC SIGNAL CONTROLLER EQUIPMENT  
 FOR THIS PROJECT SHALL BE "ECONOLITE"  
 TO MATCH THE EXISTING ADJACENT SYSTEM.

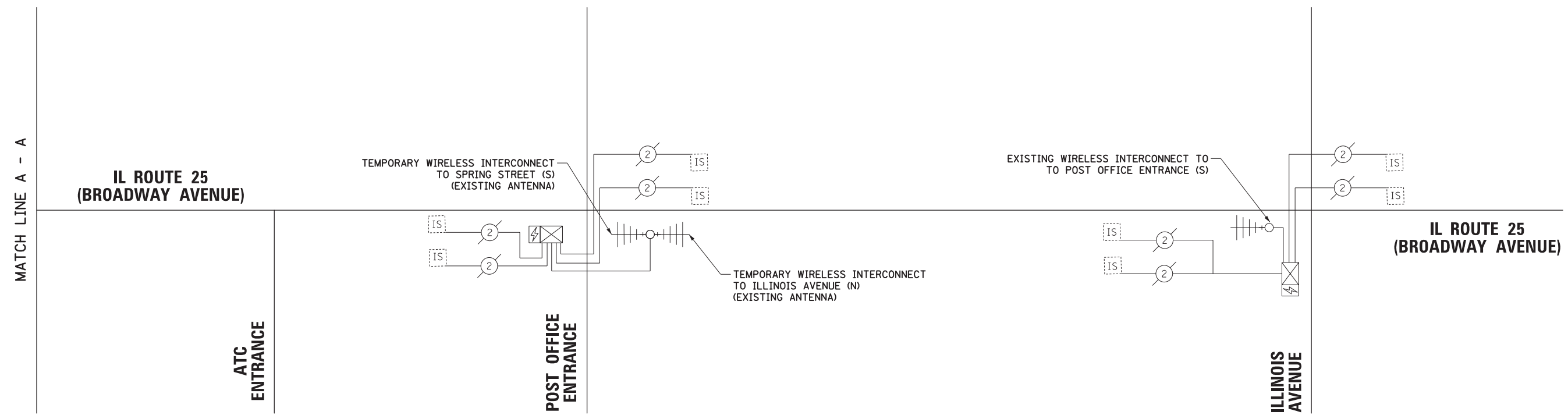

TS SHT NO. 25

MATCH LINE A - A

MATCH LINE A - A

**AURORA CENTRACS**

FILE NAME =	USER NAME = bweich	DESIGNED - EAJ	REVISED -
\\cbbelserver\cbbel\df\WBK\150077.2\Traffic\TS17-SCH_Temporary.dgn		DRAWN - FPB	REVISED -
Default	PLOT SCALE = 48"	CHECKED - TFS	REVISED -
	PLOT DATE = 10/17/2017	DATE - 10/17/2017	REVISED -

**STATE OF ILLINOIS  
 DEPARTMENT OF TRANSPORTATION**

<b>TEMPORARY INTERCONNECT SCHEMATIC DIAGRAM        IL ROUTE 25 (BROADWAY AVENUE) FROM        NEW YORK STREET TO ILLINOIS AVEBNUE</b>			
SCALE: N.T.S.	SHEET	OF 254 SHEETS	STA. TO STA.

F.A.U. RTE.	SECTION	COUNTY	TOTAL SHEETS	SHEET NO.
2503	16-00313-00-MS	KANE	254	132
CONTRACT NO.				
ILLINOIS FED. AID PROJECT				



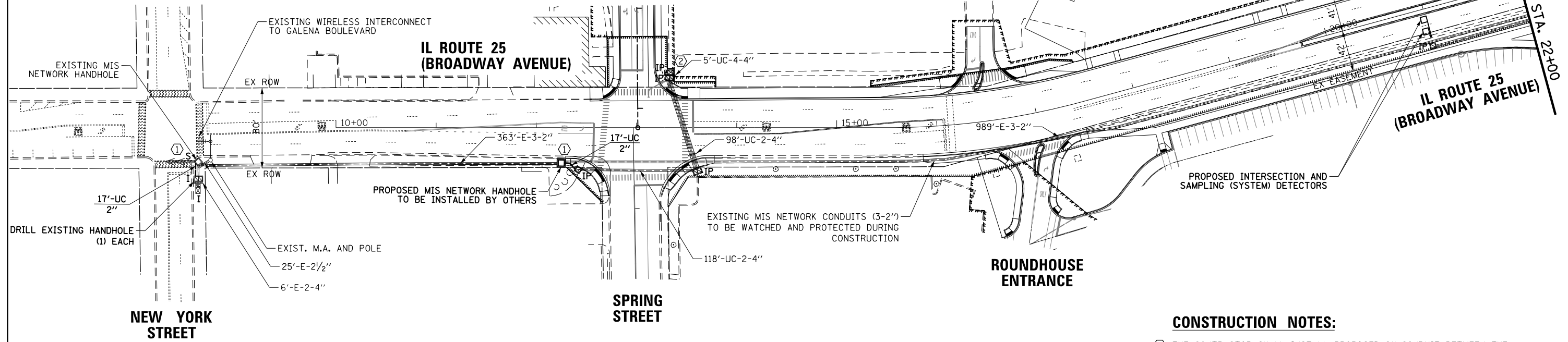
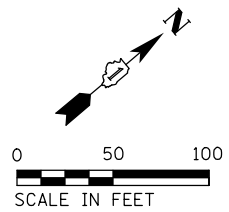

**CONSTRUCTION NOTES:**

- ① THE CONTRACTOR SHALL INSTALL PROPOSED 2" CONDUIT BETWEEN THE MIS NETWORK HANDHOLE AND THE TRAFFIC SIGNAL HANDHOLE AS SHOWN ON THE PLANS OR AS DIRECTED BY THE ENGINEER. THE MIS NETWORK HANDHOLES ARE BOTTOMLESS FIBERGLASS HANDHOLES WITH PUNCH-OUT PANELS FOR ACCESS. THE CONTRACTOR SHALL INSTALL 36 SM FIBER OPTIC CABLE FROM THE TRAFFIC SIGNAL CABINET TO THE MIS NETWORK HANDHOLE. THE MIS NETWORK HANDHOLE WILL HAVE A SPLICE ENCLOSURE THAT THE CONTRACTOR WILL USE TO TERMINATE THE 36 SM FIBER OPTIC CABLE. ALL OTHER TERMINATIONS ON THE 144 SM FIBER OPTIC CABLE WILL BE PERFORMED BY OTHERS.
- ② THE CONTRACTOR SHALL INSTALL AN ETHERNET SWITCH IN THE TRAFFIC SIGNAL CONTROLLER CABINET.

NOTE:  
THE TRAFFIC SIGNAL CONTROLLER EQUIPMENT FOR THIS PROJECT SHALL BE "ECONOLITE" TO MATCH THE EXISTING ADJACENT SYSTEM.

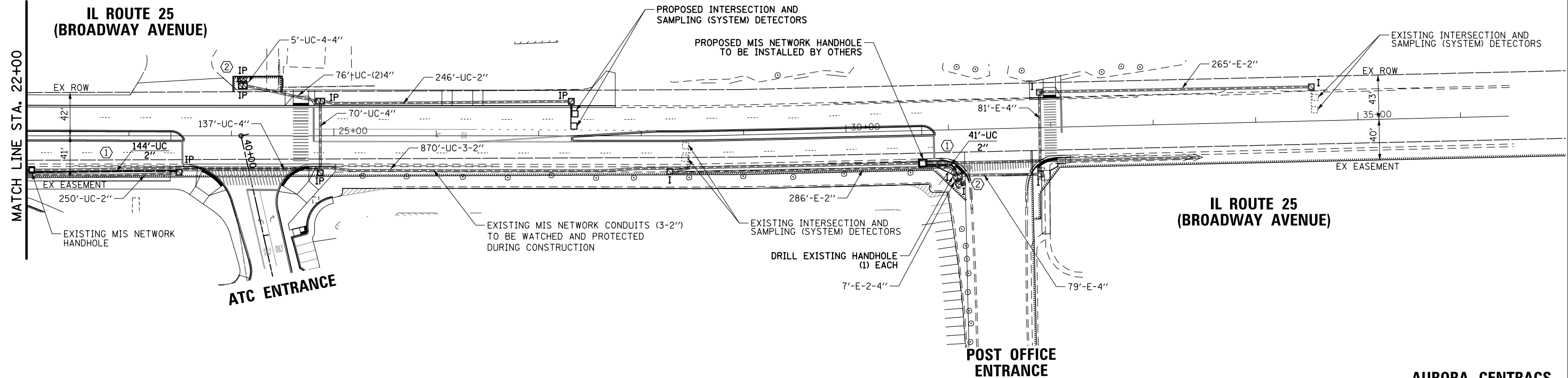

TS SHT NO. 26

FILE NAME = \\cbbel\svr\cbbel\df\WBK\150077.2\Traf\1518-INT_Proposed.dgn Default	USER NAME = bweich	DESIGNED - EAJ	REVISED -	<b>STATE OF ILLINOIS DEPARTMENT OF TRANSPORTATION</b>	<b>INTERCONNECT PLAN IL ROUTE 25 (BROADWAY AVENUE) FROM NEW YORK STREET TO POST OFFICE ENTRANCE</b>		F.A.U. RTE. = 2503	SECTION = 16-00313-00-MS	COUNTY = KANE	TOTAL SHEETS = 254	SHEET NO. = 133
	PLOT SCALE = 100'	CHECKED - TFS	REVISED -		SCALE: 100'	SHEET OF 254 SHEETS	STA. TO STA.	CONTRACT NO. ILLINOIS FED. AID PROJECT			
	PLOT DATE = 12/4/2017	DATE = 12/4/2017	REVISED -								

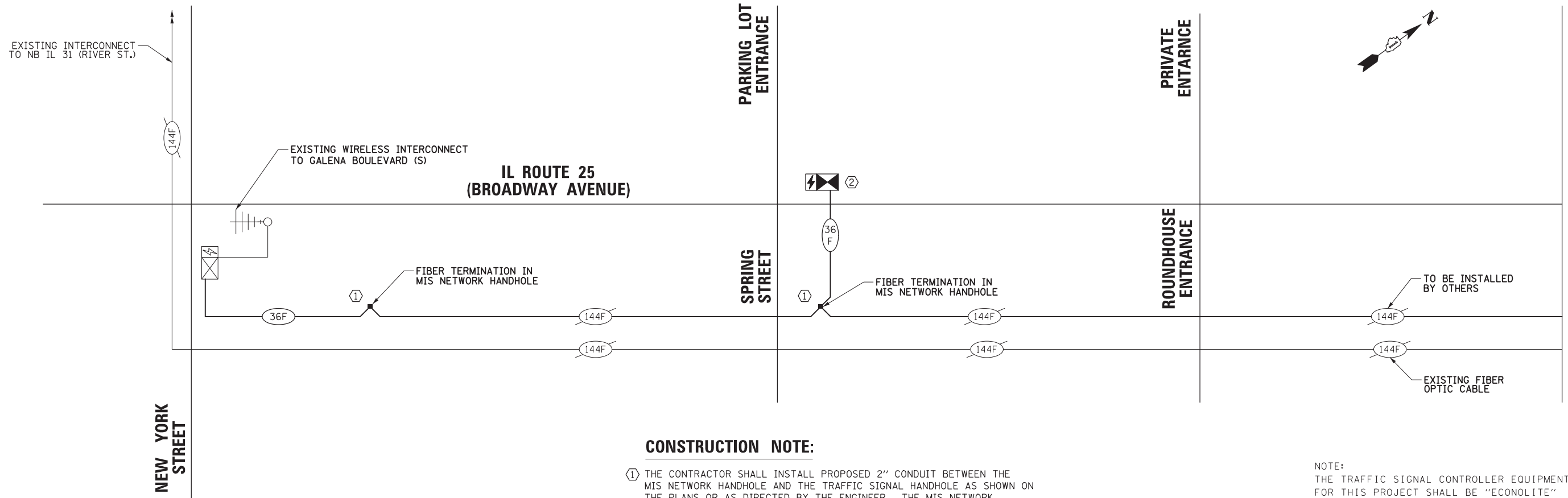

**CONSTRUCTION NOTE:**

- ① THE CONTRACTOR SHALL INSTALL PROPOSED 2" CONDUIT BETWEEN THE MIS NETWORK HANDHOLE AND THE TRAFFIC SIGNAL HANDHOLE AS SHOWN ON THE PLANS OR AS DIRECTED BY THE ENGINEER. THE MIS NETWORK HANDHOLES ARE BOTTOMLESS FIBERGLASS HANDHOLES WITH PUNCH-OUT PANELS FOR ACCESS. THE CONTRACTOR SHALL INSTALL 36 SM FIBER OPTIC CABLE FROM THE TRAFFIC SIGNAL CABINET TO THE MIS NETWORK HANDHOLE. THE MIS NETWORK HANDHOLE WILL HAVE A SPLICE ENCLOSURE THAT THE CONTRACTOR WILL USE TO TERMINATE THE 36 SM FIBER OPTIC CABLE. ALL OTHER TERMINATIONS ON THE 144 SM FIBER OPTIC CABLE WILL BE PERFORMED BY OTHERS.
- ② THE CONTRACTOR SHALL INSTALL AN ETHERNET SWITCH IN THE TRAFFIC SIGNAL CONTROLLER CABINET.

NOTE:  
THE TRAFFIC SIGNAL CONTROLLER EQUIPMENT FOR THIS PROJECT SHALL BE "ECONOLITE" TO MATCH THE EXISTING ADJACENT SYSTEM.

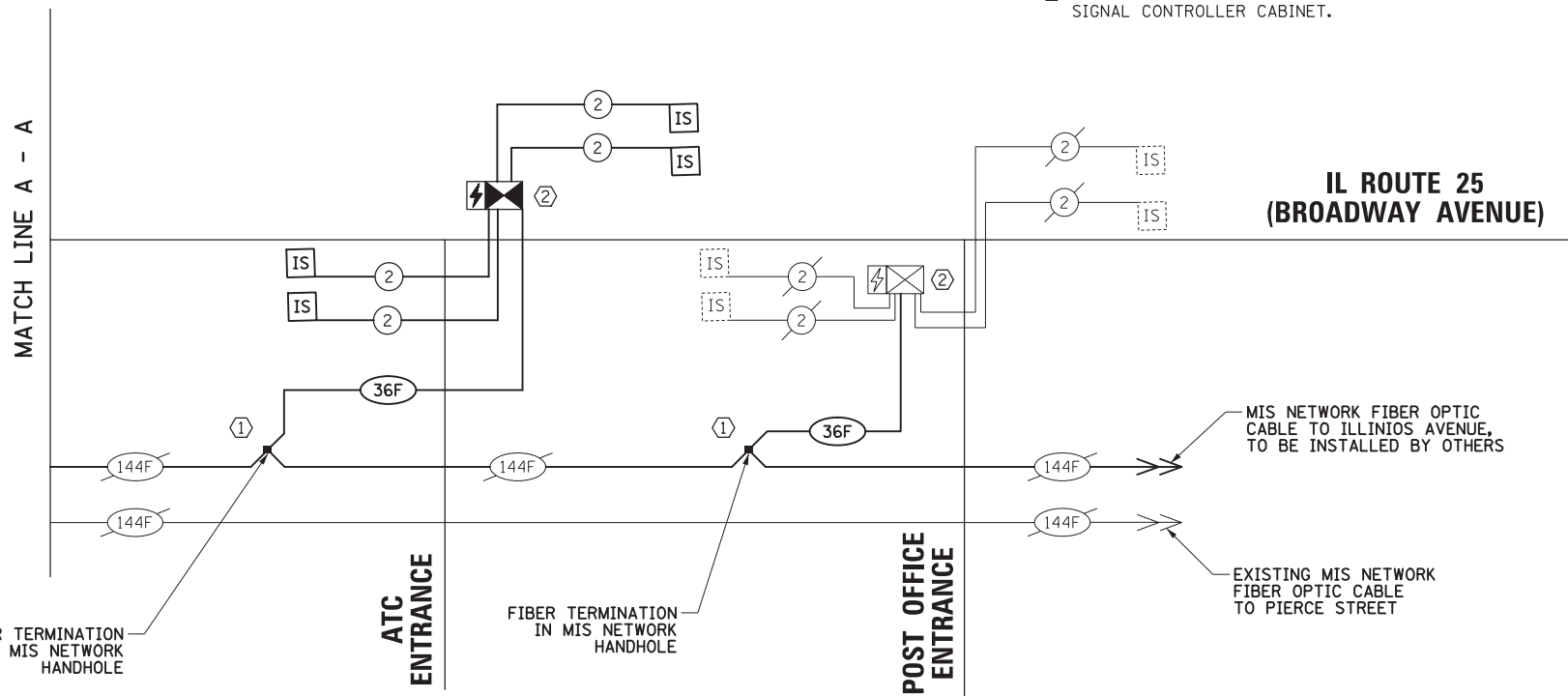

**SCHEDULE OF QUANTITIES**

ITEM	UNT	QUANTITY
UNDERGROUND CONDUIT, GALVANIZED STEEL, 2" DIA.	FOOT	219
MAINTENANCE OF EXISTING TRAFFIC SIGNAL INSTALLATION	EACH	1
TRANSCEIVER - FIBER OPTIC	EACH	2
DRILL EXISTING HANDHOLE	EACH	2
ETHERNET SWITCH	EACH	3
FIBER OPTIC CABLE 36 FIBERS, SINGLE MODE	FOOT	873
CENTRALIZED SYSTEM FIELD INTEGRATION/ SETUP	LSUM	1
RE-OPTIMIZE TRAFFIC SIGNAL SYSTEM LEVEL 2	EACH	4

TS SHT NO. 27

FILE NAME =	USER NAME = bweich	DESIGNED - EAJ	REVISED -
\\cbbelserver\cbbel\df\WBK\150077.2\Traffic\TS19-SCH.Proposed.dgn		DRAWN - FPB	REVISED -
Default	PLOT SCALE = 48"	CHECKED - TFS	REVISED -
	PLOT DATE = 10/17/2017	DATE - 10/17/2017	REVISED -

**STATE OF ILLINOIS  
DEPARTMENT OF TRANSPORTATION**

**INTERCONNECT SCHEMATIC DIAGRAM  
IL ROUTE 25 (BROADWAY AVENUE) FROM  
NEW YORK STREET TO ILLINOIS AVEBNU**

SCALE: N.T.S. SHEET OF 254 SHEETS STA. TO STA.

F.A.U. RTE.	SECTION	COUNTY	TOTAL SHEETS	SHEET NO.
2503	16-00313-00-MS	KANE	254	134
CONTRACT NO.				
ILLINOIS FED. AID PROJECT				

**AURORA CENTRACS**

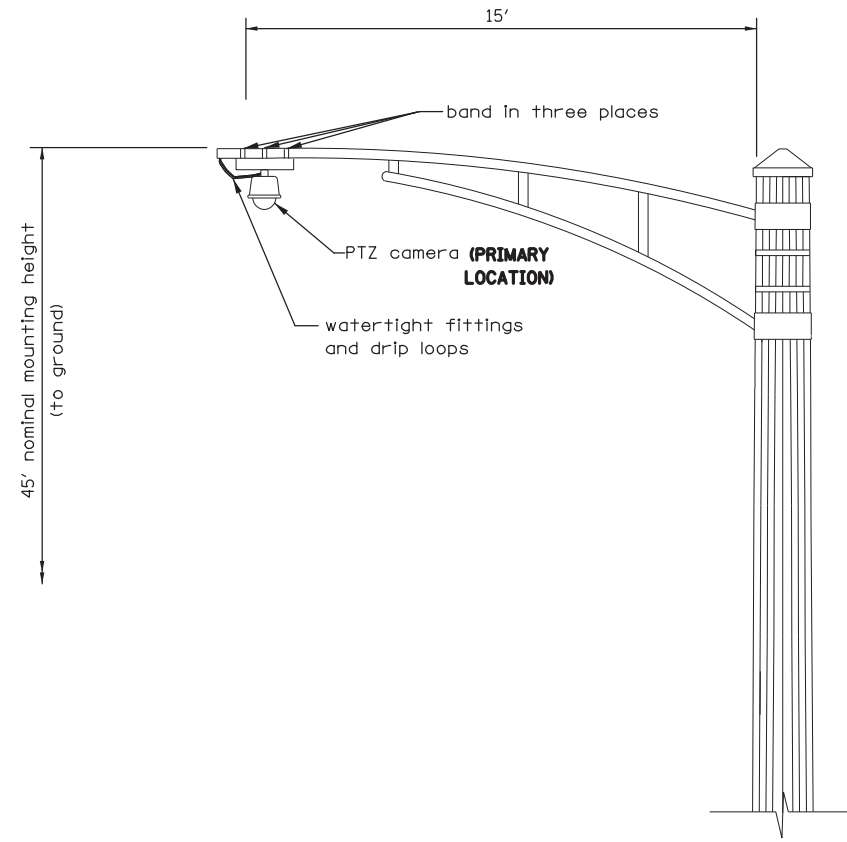

DOME (PTZ) CAMERA MOUNTING DETAIL

(NOT TO SCALE)

NOTES FOR CAMERA MOUNTING:

- MOUNT LUMINAIRE MOUNTING BRACKET AS HIGH AS POSSIBLE.
- PTZ CAMERA SHALL BE MOUNTED TOWARDS THE END OF THE LUMINAIRE ARM.

TS SHT NO. 28

FILE NAME =	USER NAME = bweich	DESIGNED - EAJ	REVISED -
\\cbbelserver\cbbel\dt\WBK\150077.2\Traffic\TS20-DET_PTZ.dgn		DRAWN - FPB	REVISED -
Default	PLOT SCALE = 48"	CHECKED - TFS	REVISED -
	PLOT DATE = 10/17/2017	DATE - 10/17/2017	REVISED -

**STATE OF ILLINOIS  
DEPARTMENT OF TRANSPORTATION**

**PTZ MOUNTING DETAIL SHEET**

SCALE: N/A S. SHEET OF 254 SHEETS STA. TO STA.

F.A.U. RTE.	SECTION	COUNTY	TOTAL SHEETS	SHEET NO.
2503	16-00313-00-MS	KANE	254	135
CONTRACT NO.				
ILLINOIS FED. AID PROJECT				

## GENERAL NOTES

1. ELECTRICAL CONTRACTOR SHALL BE RESPONSIBLE FOR OBTAINING A PERMIT FROM THE CITY OF AURORA BEFORE THE START OF WORK, ANY COST FOR PERMIT SHALL BE INCLUDED IN THE COST OF THE CONTRACT.
2. BEFORE INSTALLING LIGHT STANDARDS NEAR OVERHEAD AND UNDERGROUND ELECTRIC UTILITIES SHALL CALL COM ED FOR LOCATION APPROVAL AND MINIMUM CLEARANCE REQUIREMENTS.
3. THE WORK PERFORMED UNDER THIS CONTRACT SHALL IN NO WAY INTERFERE WITH THE NORMAL OPERATION OF ANY EXISTING UTILITY SERVICE. THE CONTRACTOR SHALL FURNISH ALL NECESSARY ITEMS OF EQUIPMENT REQUIRED TO MAINTAIN SUCH NORMAL OPERATION AT NO ADDITIONAL COST TO THE OWNER. THE COST ASSOCIATED FOR THIS WORK SHALL BE CONSIDERED INCLUDED IN THE COST OF THE CONTRACT, AND NO ADDITIONAL COMPENSATION SHALL BE AWARDED.
4. THE CONTRACTOR SHALL BE SOLELY RESPONSIBLE FOR JOB SITE SAFETY AS WELL AS SUPERVISION/DIRECTION AND MEANS/METHODS OF CONSTRUCTION.
5. ALL WORK SHALL BE IN ACCORDANCE WITH THE LATEST EDITIONS OF THE FOLLOWING SPECIFICATIONS, WHICH ARE HEREBY MADE A PART HEREOF:
  - A. "STANDARD SPECIFICATIONS FOR ROAD AND BRIDGE CONSTRUCTION", AS PREPARED BY IDOT.
  - B. "THE NATIONAL ELECTRICAL CODE".
  - C. MUNICIPAL CODES & STANDARDS.
6. NO MATERIALS SHALL BE DELIVERED TO THE JOB SITE UNTIL ALL PERTINENT EQUIPMENT SUBMITTALS HAVE BEEN REVIEWED BY THE ENGINEER.
7. CAST A GROUND ROD INSIDE EVERY CONCRETE POLE FOUNDATION AND CONNECT TO THE POLE GROUNDING LUG VIA A #6 SOLID COPPER WIRE WITH A MECHANICAL CONNECTION AT THE GROUND ROD AND PIGTAIL SPLICE INSIDE THE POLE HANDHOLE.
8. ALL UNDERGROUND WIRING SHALL BE COPPER (OR SIZE AS SHOWN ON THE PLANS) XLP TYPE-USE, EXTRA ABRASION RESISTANCE, 600 VOLTS, INSTALLED IN SCH 40 HDPE CONDUIT A MINIMUM 30 INCHES BELOW FINISHED GRADE, FOLLOWING THE ROADWAY OR SIDEWALK EDGE.
9. LUMINAIRES SHALL BE LEVEL & HAVE A TIGHT FIT ON POLE/LUMINAIRE ARMS TO THE VILLAGE'S SATISFACTION. LUMINAIRE HOUSE SIDE SHIELDS SHALL BE PROVIDED AT LOCATIONS INDICATED ON THE PLANS, OR AS DIRECTED BY THE ENGINEER. FIELD ADJUSTING OF THE LUMINAIRE SHALL BE INCLUDED IN THE UNIT PRICE COST FOR THE LUMINAIRE.
10. TO MAINTAIN THE STRUCTURAL INTEGRITY OF LIGHT POLES WITH LUMINAIRE ARMS, THEY SHALL NOT BE ERECTED AND LEFT TO STAND WITHOUT LUMINAIRES.
11. ALL POLE HANDHOLES SHALL FACE AWAY FROM TRAFFIC.
12. THE ELECTRICAL CONTRACTOR SHALL FURNISH TWO SETS OF FULL SIZE RECORD DRAWINGS TO THE OWNER'S REPRESENTATIVE UPON COMPLETION OF THE LIGHTING AND ELECTRICAL IMPROVEMENTS. THE DRAWINGS SHALL SHOW THE INSTALLED LOCATIONS OF ALL LIGHT POLES, UNDERGROUND CONDUITS/WIRING, HANDHOLES, JUNCTION BOXES & CONTROLLER CABINETS. THE DRAWINGS WILL BE REVIEWED BY THE ENGINEER.
13. UPON COMPLETION OF THE PROPOSED LIGHTING IMPROVEMENTS, THE CONTRACTOR SHALL PERFORM ELECTRICAL TESTING AND VERIFY THAT THE INSTALLATION COMPLIES WITH THE LATEST EDITION OF THE STANDARD SPECIFICATIONS FOR ROAD AND BRIDGE CONSTRUCTION IN ILLINOIS. ALL ELECTRICAL TESTING SHALL BE PERFORMED IN THE PRESENCE OF THE ENGINEER AND THE VILLAGE.
14. CONTRACTOR SHALL USE A STANDARD CONCRETE FOUNDATION WHEREVER POSSIBLE. IF UTILITY CONFLICTS PROHIBIT THE USE OF A STANDARD CONCRETE FOUNDATION, THE CONTRACTOR SHALL CONSULT WITH OWNER'S REPRESENTATIVE PRIOR TO THE USE OF AN OFFSET FOUNDATION.
15. BACKFILL MATERIAL FOR TRENCHES IN THE SUBGRADE OF THE PROPOSED IMPROVEMENT, AND FOR TRENCHES OUTSIDE OF THE SUBGRADE WHERE THE INNER EDGE OF THE TRENCH IS WITHIN 2 FT OF THE EDGE OF THE PAVEMENT, CURB, GUTTER, CURB AND GUTTER, STABILIZED SHOULDER, OR SIDEWALK SHALL BE TRENCH BACKFILL.

16. CARE IS TO BE TAKEN AS NOT TO DAMAGE ANY OF THE EXISTING TRAFFIC SIGNAL CONDUITS, DETECTORS AND EQUIPMENT. IF ANY OF THE TRAFFIC SIGNAL CONDUIT AND/OR EQUIPMENT IS DAMAGED, THE CONTRACTOR SHALL REPAIR AND/OR REPLACE THE CONDUIT AND/OR EQUIPMENT AT NO COST.
17. THE CONTRACTOR SHALL MAKE SPECIAL NOTE OF THE REQUIREMENT FOR BURIED WARNING TAPE, SPECIFIED AS PART OF "TRENCH AND BACKFILL FOR ELECTRICAL WORK". THE INSTALLATION OF THE TAPE SHALL BE INSPECTED AND APPROVED BY THE RESIDENT ENGINEER PRIOR TO BACKFILLING OR DURING PLOWING OPERATIONS, AS APPLICABLE.
18. THE CONTRACTOR SHALL BE RESPONSIBLE FOR THE ESTABLISHMENT OF FINISHED GRADE. THE RESIDENT ENGINEER MAY ASSIST THE CONTRACTOR, AS APPLICABLE, BUT THE RESPONSIBILITY FOR COORDINATING THE FINISHED GRADE ELEVATION WITH THE TOP OF THE FOUNDATION HEIGHT AND THE LIGHT SHALL REMAIN WITH THE CONTRACTOR.
19. NO POLES SHALL BE ERECTED UNTIL THE RESPECTIVE FOUNDATIONS HAVE CURED, (IF APPLICABLE) AND HAVE BEEN REVIEWED BY THE ENGINEER.
20. THE CONTRACTOR SHALL MAKE SPECIAL NOTE OF THE REQUIREMENTS FOR WIRE MARKERS AND SHALL TAG ALL WIRE MARKERS AND SHALL TAG ALL WIRE ACCORDINGLY.
21. EQUIPMENT GROUND CONDUCTORS SHALL BE SPLICED AND BONDED AT EACH LIGHT POLE OR OTHER PIECE OF EQUIPMENT.
22. CONDUIT MUST BE POSITIONED IN THE FIELD TO AVOID CONFLICT WITH TREES, BUSHES, DRAINS AND OTHER UTILITIES AND LANDSCAPING.
23. THE EXACT LOCATIONS OF ALL UTILITIES SHALL BE VERIFIED BY THE CONTRACTOR BEFORE THE INSTALLATION OF ANY COMPONENTS OF THE LIGHTING SYSTEM, FOR THE LOCATIONS OF THE UTILITIES, CALL JULIE TOLL FREE AT 1-800-892-0123. IT IS THE CONTRACTOR'S RESPONSIBILITY TO LOCATE EXISTING TRAFFIC SIGNAL CABLES AND CONDUITS.
24. IT SHALL BE THE CONTRACTOR'S RESPONSIBILITY TO MARK THE PROPOSED LOCATIONS OF ALL LIGHT POLES AND LIGHTING CONTROLLERS FOR EXAMINATION AND CONFIRMATION WITH THE RESIDENT ENGINEER AT THE PRECONSTRUCTION INSPECTION. THE CONTRACTOR SHALL VERIFY ALL UTILITY LOCATIONS PRIOR TO AUGERING FOR LIGHT POLE FOUNDATIONS. THE EXACT LOCATIONS OF ALL ITEMS SHALL BE CONFIRMED WITH THE RESIDENT ENGINEER PRIOR TO STARTING WORK.
25. THE CONTRACTOR SHALL BE RESPONSIBLE FOR TIMELY NOTIFICATION AND ALL COORDINATION WITH COM ED FOR NEW ELECTRIC SERVICE TO THE PROPOSED LIGHTING CONTROLLERS. THE ELECTRIC SERVICE COORDINATION PERFORMED BY THE ENGINEER DURING DESIGN IS INCLUDED IN THE PLANS FOR THE CONTRACTORS INFORMATION.
26. THE LIGHT POLE LOCATIONS SHALL COMPLY WITH THE MINIMUM CLEAR WIDTH FOR AN ACCESSIBLE ROUTE FOR SIDEWALKS PER CURRENT AMERICAN WITH DISABILITIES ACT (ADA) REQUIREMENTS.

## LIGHTING BILL OF MATERIALS

CODE NUMBER	DESCRIPTION	UNIT	QUANTITY
20800150	TRENCH BACKFILL	CU YD	745
80400100	ELECTRIC SERVICE INSTALLATION	EACH	1
*80400200	ELECTRIC UTILITY SERVICE CONNECTION	LSUM	1
81028200	UNDERGROUND CONDUIT, GALVANIZED STEEL, 2" DIA.	FOOT	20
81028210	UNDERGROUND CONDUIT, GALVANIZED STEEL, 2 1/2" DIA.	FOOT	450
81028320	UNDERGROUND CONDUIT, PVC, 1" DIA.	FOOT	100
81028350	UNDERGROUND CONDUIT, PVC, 2" DIA.	FOOT	7450
81028730	UNDERGROUND CONDUIT, COILABLE NONMETALLIC CONDUIT, 1 1/4" DIA.	FOOT	5280
*81400730	HANDHOLE, COMPOSITE CONCRETE	EACH	28
81702120	ELECTRIC CABLE IN CONDUIT, 600V (XLP-TYPE USE) 1/C NO. 8	FOOT	28490
81702130	ELECTRIC CABLE IN CONDUIT, 600V (XLP-TYPE USE) 1/C NO. 6	FOOT	13480
81702145	ELECTRIC CABLE IN CONDUIT, 600V (XLP-TYPE USE) 1/C NO. 3	FOOT	290
81702150	ELECTRIC CABLE IN CONDUIT, 600V (XLP-TYPE USE) 1/C NO. 2	FOOT	7150
82500350	LIGHTING CONTROLLER, BASE MOUNTED, 240VOLT, 100AMP	EACH	1
83006200	LIGHT POLE, ALUMINUM, 30 FT. M.H., 6 FT. MAST ARM	FOOT	8
83600200	LIGHT POLE FOUNDATION, 24" DIAMETER	FOOT	140
84200500	REMOVAL OF LIGHTING UNIT, SALVAGE	EACH	37
84200804	REMOVAL OF POLE FOUNDATION	EACH	39
84400105	RELOCATE EXISTING LIGHTING UNIT	EACH	2
87300010	GROUNDING EXISTING HANDHOLE FRAME AND COVER	EACH	1
87900200	DRILL EXISTING HAND HOLE	EACH	8
*X0320031	SIGN LIGHTING UNIT COMPLETE	EACH	2
*X0325815	REMOVE EXISTING CABLE	FOOT	440
*X0326366	ELECTRICAL EQUIPMENT REMOVAL AND SALVAGE	EACH	2
*X0326654	ORNAMENTAL LIGHT UNIT, COMPLETE	EACH	40
*X0327303	REMOVAL OF EXISTING SIGN LIGHTING UNIT WITH NO SALVAGE	EACH	1
*X0327739	MISCELLANEOUS ELECTRICAL WORK	LSUM	1
*X1400088	POWER PEDESTALS	EACH	3
*X1400095	LUMINAIRE, LED, HORIZONTAL MOUNT, HIGH WATTAGE	EACH	14
*X1400211	LIGHT POLE, SPECIAL, 30'	EACH	3
*X8140230	HANDHOLE, COMPOSITE CONCRETE (SPECIAL)	EACH	2
*X8360210	LIGHT POLE FOUNDATION, 24" DIAMETER, SPECIAL	FOOT	330
*X8360215	LIGHT POLE FOUNDATION, 24" DIAMETER, OFFSET	FOOT	105
*XX003079	REMOVE JUNCTION BOX	EACH	8
*XX006614	MODIFY EXISTING CABINET EQUIPMENT AND APPURTENANCES	EACH	1
*Z0033028	MAINTENANCE OF LIGHTING SYSTEM	CAL MO	9

• SEE SPECIAL PROVISION

## ABBREVIATIONS

A	AMPS	HPS	HIGH PRESSURE SODIUM
CKT	CIRCUIT	PVC	POLYVINYL CHLORIDE
CNC	COILABLE NON-METALLIC CONDUIT	RGS	RIGID GALVANIZED STEEL CONDUIT
DIA	DIAMETER	ROW	RIGHT OF WAY
FT	FOOT	SS	STAINLESS STEEL
FOC	FACE OF CURB	STA	STATION
GFCI	GROUND FAULT CIRCUIT INTERRUPTER	V	VOLTS
GND	GROUND	W	WATTS
HDPE	HIGH DENSITY POLYETHYLENE	WR	WEATHER RESISTANT
HH	HAND HOLE		

FILE NAME -	USER NAME - adericco	DESIGNED - AJD	REVISED -	<b>STATE OF ILLINOIS DEPARTMENT OF TRANSPORTATION</b>	<b>AURORA TRANSIT CENTER IMPROVEMENTS LIGHTING GENERAL NOTES &amp; BILL OF MATERIALS</b>	F.A.U. RTE.	SECTION	COUNTY	TOTAL SHEETS	SHEET NO.
N:\WBK\150077.2\Mech\NOT_150077.2-01.sht		DRAWN - JRB	REVISED -			2503	16-00313-00-MS	KANE	254	136
Default		CHECKED - AJD	REVISED -			<b>CONTRACT NO. 61E18</b>				
	PLOT DATE - 11/7/2017	DATE - 11/7/2017	REVISED -			ILLINOIS FED. AID PROJECT				

SCALE: N.T.S. SHEET OF 254 SHEETS STA. TO STA.

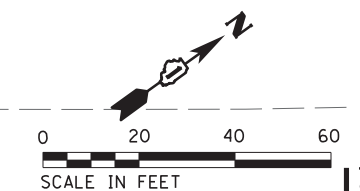
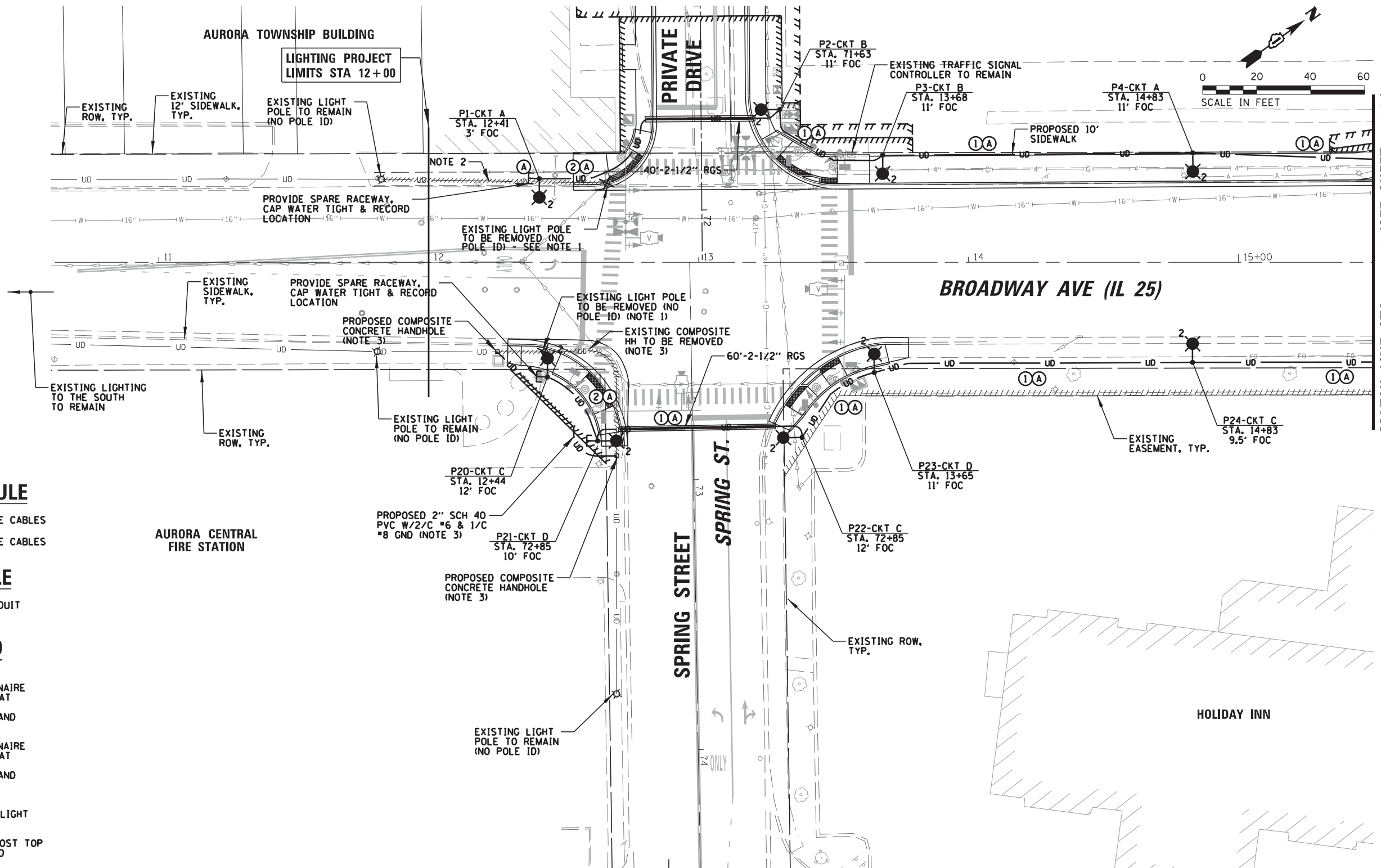

MATCH LINE STA 15+50 (SEE SHEET 138)

**CONDUCTOR SCHEDULE**

- ① 4/C #8 & 1/C #8 GND XLP-TYPE USE CABLES
- ② 2/C #8 & 1/C #8 GND XLP-TYPE USE CABLES

**CONDUIT SCHEDULE**

- (A) 1-1/4" Ø SCH 40 HDPE CONDUIT

**LIGHTING LEGEND**

- PROPOSED 175W LED TYPE LUMINAIRE WITH TYPE 2 OPTICS MOUNTED AT 40 FT ON A DECORATIVE STEEL LIGHT POLE WITH A 6 FT ARM AND BANNER ARMS
- PROPOSED 175W LED TYPE LUMINAIRE WITH TYPE 2 OPTICS MOUNTED AT 40 FT ON A DECORATIVE STEEL LIGHT POLE WITH A 6 FT ARM AND WITHOUT BANNER ARMS
- EXISTING CITY OF AURORA OWNED & MAINTAINED ROADWAY LIGHT POLE
- EXISTING 150W METAL HALIDE POST TOP ACORN TYPE LUMINAIRE MOUNTED ON A 12' DECORATIVE ALUMINUM LIGHT POLE
- EXISTING PRIVATELY OWNED & MAINTAINED PARKING LIGHT POLE
- EXISTING LIGHT POLE TO BE REMOVED
- LIGHT POLE IDENTIFIER
- ROADWAY LUMINAIRE CIRCUIT IDENTIFIER
- STATION
- SETBACK FROM FACE OF CURB (FOC) TO CENTER OF POLE
- PROPOSED CONDUIT

- NOTES:**
- AFTER PROPOSED LIGHTING IS INSTALLED AND OPERATIONAL, THE CONTRACTOR SHALL DISCONNECT AND REMOVE EXISTING LIGHT POLE AND LUMINAIRE AND RETURN TO CITY OF AURORA. CONCRETE FOUNDATION SHALL BE REMOVED AND DISPOSED OF.
  - AFTER EXISTING LIGHTING HAS BEEN DISCONNECTED, CONTRACTOR SHALL REMOVE EXISTING CONDUIT/WIRE TO 1 FOOT BELOW GRADE AND ABANDON.
  - EXISTING ELECTRIC FEED TO EXISTING LIGHT POLE ON SPRING STREET SHALL BE RELOCATED BY INSTALLING NEW HANDHOLE, CONDUIT AND WIRE AS SHOWN. CONTRACTOR SHALL LOCATE EXISTING CONDUITS AND CONNECT INTO NEW CONDUIT/HANDHOLE. INSTALL NEW CABLES AND SPLICE INTO EXISTING CABLES IN HANDHOLES.

FILE NAME = N:\WBK\150077.2\Mech\LTG\150077.2.01.sht	USER NAME = aderricco	DESIGNED - AJD	REVISED -	<b>STATE OF ILLINOIS DEPARTMENT OF TRANSPORTATION</b>	<b>AURORA TRANSIT CENTER IMPROVEMENTS ROADWAY LIGHTING PLAN (1 OF 3)</b>	F.A.U. RTE.	SECTION	COUNTY	TOTAL SHEETS	SHEET NO.	
Default	PLOT SCALE = 48"	CHECKED - AJD	REVISED -			2503	16-00313-00-MS	KANE	254	137	
	PLOT DATE = 10/16/2017	DATE - 10/16/2017	REVISED -			CONTRACT NO. 61E18					
						ILLINOIS FED. AID PROJECT					

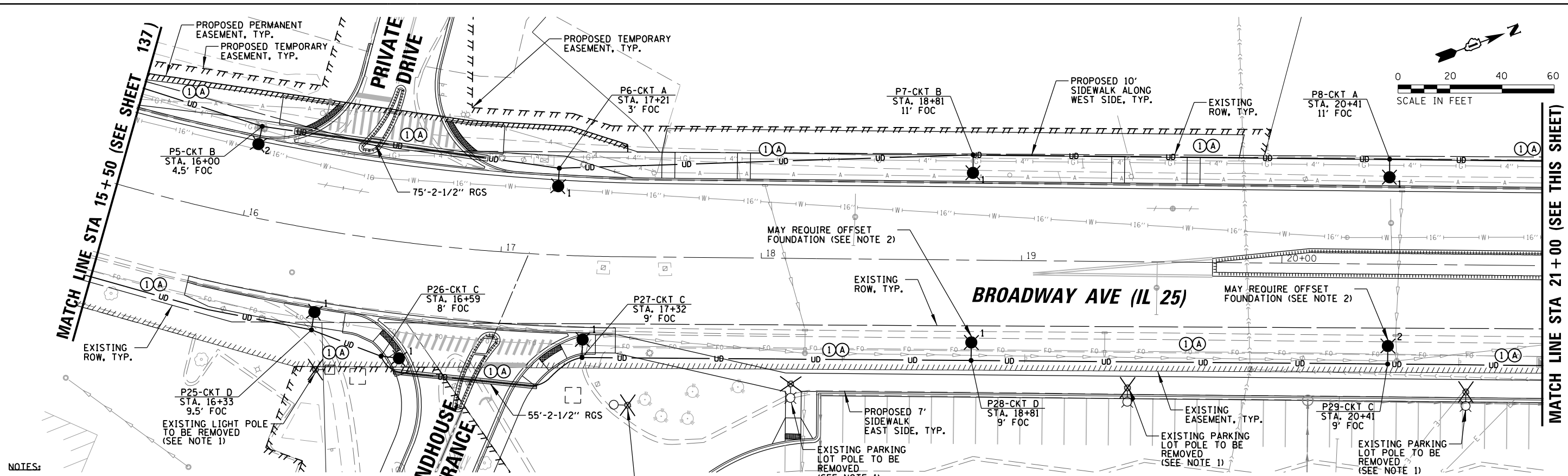
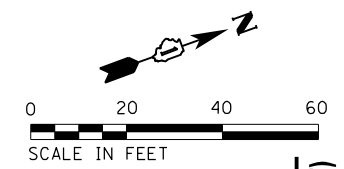

**NOTES:**

- SEE SITE LIGHTING PLAN.
- CONTRACTOR SHALL USE A STANDARD CONCRETE FOUNDATION WHEREVER POSSIBLE. IF UTILITY CONFLICTS PROHIBIT THE USE OF A STANDARD CONCRETE FOUNDATION, THE CONTRACTOR SHALL CONSULT WITH ENGINEER PRIOR TO THE USE OF AN OFFSET FOUNDATION.

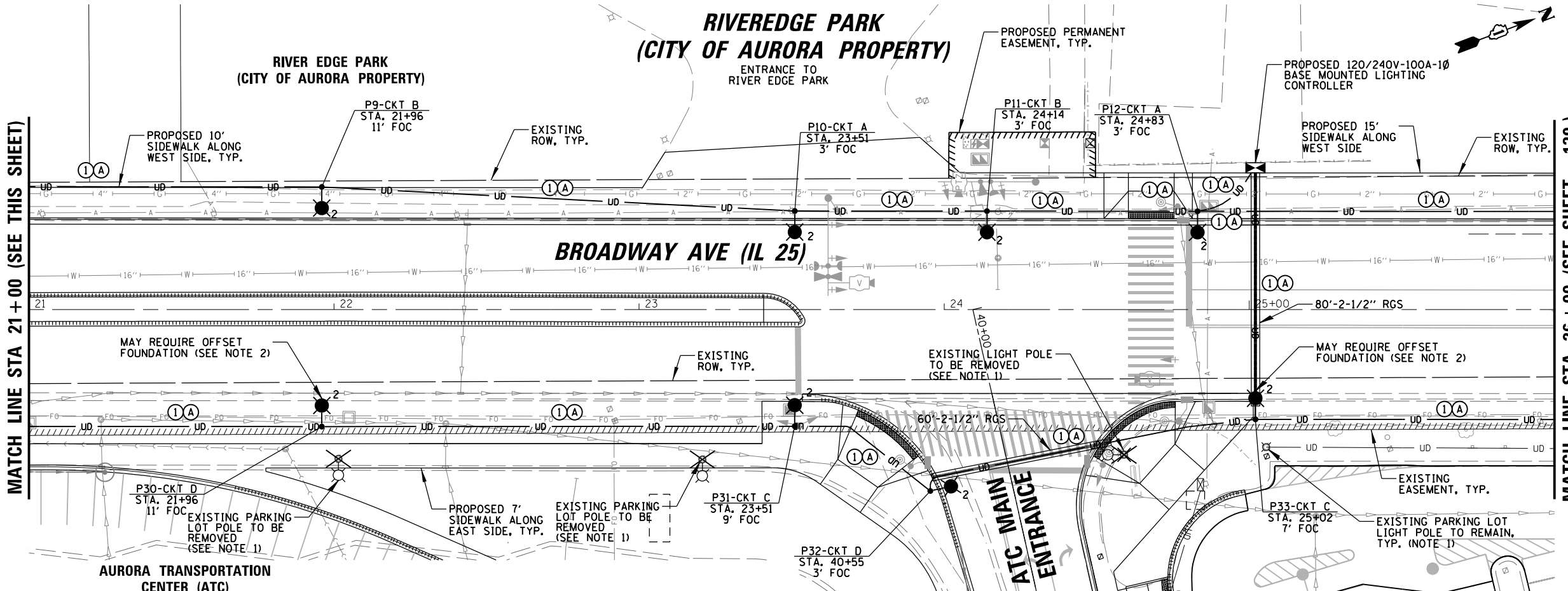

**CONDUCTOR SCHEDULE**

- ① 4/C #8 & 1/C #8 GND XLP-TYPE USE CABLES
- ② 2/C #8 & 1/C #8 GND XLP-TYPE USE CABLES

**CONDUIT SCHEDULE**

- Ⓐ 1-1/4" Ø SCH 40 HDPE CONDUIT

**LIGHTING LEGEND**

- 1 PROPOSED 175W LED TYPE LUMINAIRE WITH TYPE 2 OPTICS MOUNTED AT 40 FT ON A DECORATIVE STEEL LIGHT POLE WITH A 6 FT ARM AND BANNER ARMS
- 2 PROPOSED 175W LED TYPE LUMINAIRE WITH TYPE 2 OPTICS MOUNTED AT 40 FT ON A DECORATIVE STEEL LIGHT POLE WITH A 6 FT ARM AND WITHOUT BANNER ARMS
- ○ ○ ○ ○ EXISTING CITY OF AURORA OWNED & MAINTAINED ROADWAY LIGHT POLE
- ⊗ EXISTING 150W METAL HALIDE POST TOP ACORN TYPE LUMINAIRE MOUNTED ON A 12' DECORATIVE ALUMINUM LIGHT POLE
- ⊗ ○ ○ ○ ○ ○ EXISTING PRIVATELY OWNED & MAINTAINED PARKING LIGHT POLE
- ⊗ ○ ○ ○ ○ ○ EXISTING LIGHT POLE TO BE REMOVED
- ○ ○ ○ ○ LIGHT POLE IDENTIFIER
- ○ ○ ○ ○ ROADWAY LUMINAIRE CIRCUIT IDENTIFIER
- ○ ○ ○ ○ STATION
- ○ ○ ○ ○ SETBACK FROM FACE OF CURB (FOC) TO CENTER OF POLE
- UD — PROPOSED CONDUIT

FILE NAME =	USER NAME = bweilch	DESIGNED - AJD	REVISED -
N:\WBK\150077.2\Mech\LG1.150077.2.02.sht		DRAWN - JRB	REVISED -
Default		CHECKED - AJD	REVISED -
		DATE - 12/4/2017	REVISED -

**STATE OF ILLINOIS  
DEPARTMENT OF TRANSPORTATION**

**AURORA TRANSIT CENTER IMPROVEMENTS  
ROADWAY LIGHTING PLAN (2 OF 3)**

SCALE: N.T.S. SHEET OF 254 SHEETS STA. TO STA.

F.A.U. RTE.	SECTION	COUNTY	TOTAL SHEETS	SHEET NO.
2503	16-00313-00-MS	KANE	254	138
			CONTRACT NO. 61E18	
ILLINOIS FED. AID PROJECT				

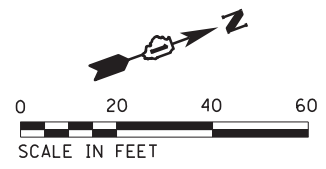

**LIGHTING LEGEND**

- 1 PROPOSED 175W LED TYPE LUMINAIRE WITH TYPE 2 OPTICS MOUNTED AT 40 FT ON A DECORATIVE STEEL LIGHT POLE WITH A 6 FT ARM AND BANNER ARMS
- 2 PROPOSED 175W LED TYPE LUMINAIRE WITH TYPE 2 OPTICS MOUNTED AT 40 FT ON A DECORATIVE STEEL LIGHT POLE WITH A 6 FT ARM AND WITHOUT BANNER ARMS
- EXISTING CITY OF AURORA OWNED & MAINTAINED ROADWAY LIGHT POLE
- ⊠ EXISTING 150W METAL HALIDE POST TOP ACORN TYPE LUMINAIRE MOUNTED ON A 12' DECORATIVE ALUMINUM LIGHT POLE
- ⊞ EXISTING PRIVATELY OWNED & MAINTAINED PARKING LIGHT POLE
- ⊗ EXISTING LIGHT POLE TO BE REMOVED
- LIGHT POLE IDENTIFIER
- PI-CKT A STA. 100+00 3.5' FOC ROADWAY LUMINAIRE CIRCUIT IDENTIFIER STATION
- SETBACK FROM FACE OF CURB (FOC) TO CENTER OF POLE
- UD — PROPOSED CONDUIT

MATCH LINE STA 26+00 (SEE SHEET 138)

MATCH LINE STA 30+50 (SEE THIS SHEET)

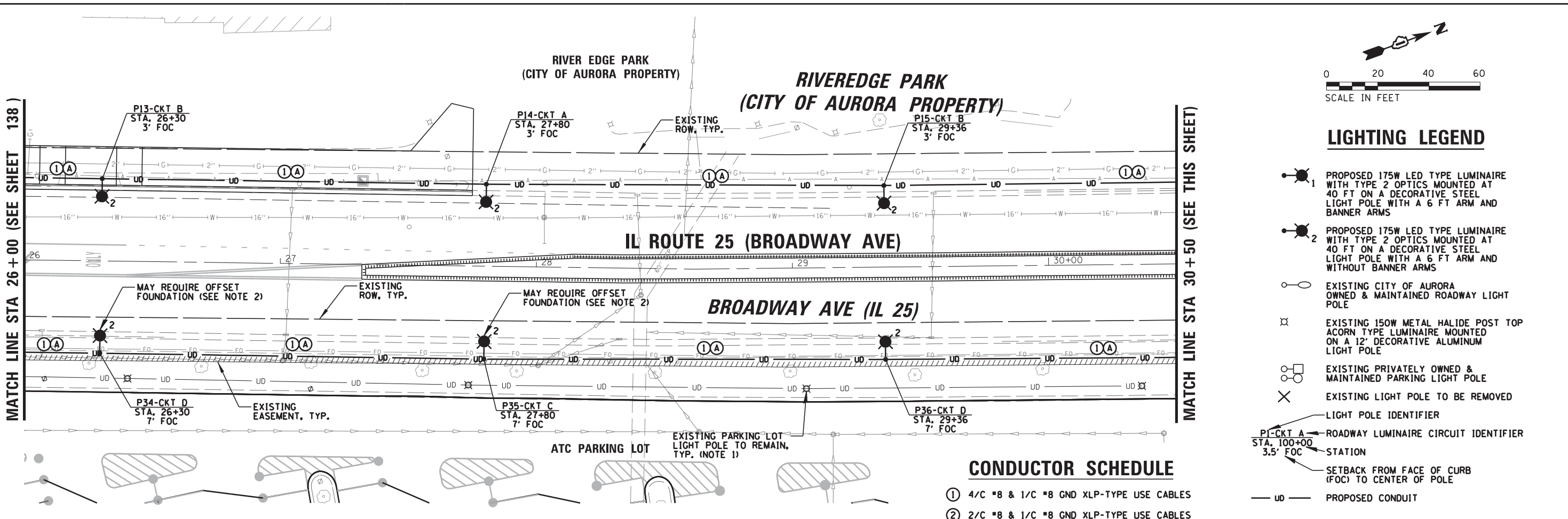

**CONDUCTOR SCHEDULE**

- ① 4/C #8 & 1/C #8 GND XLP-TYPE USE CABLES
- ② 2/C #8 & 1/C #8 GND XLP-TYPE USE CABLES

**CONDUIT SCHEDULE**

- Ⓐ 1-1/4" Ø SCH 40 HDPE CONDUIT

MATCH LINE STA 30+50 (SEE THIS SHEET)

MATCH LINE STA 35+00 (SEE THIS SHEET)

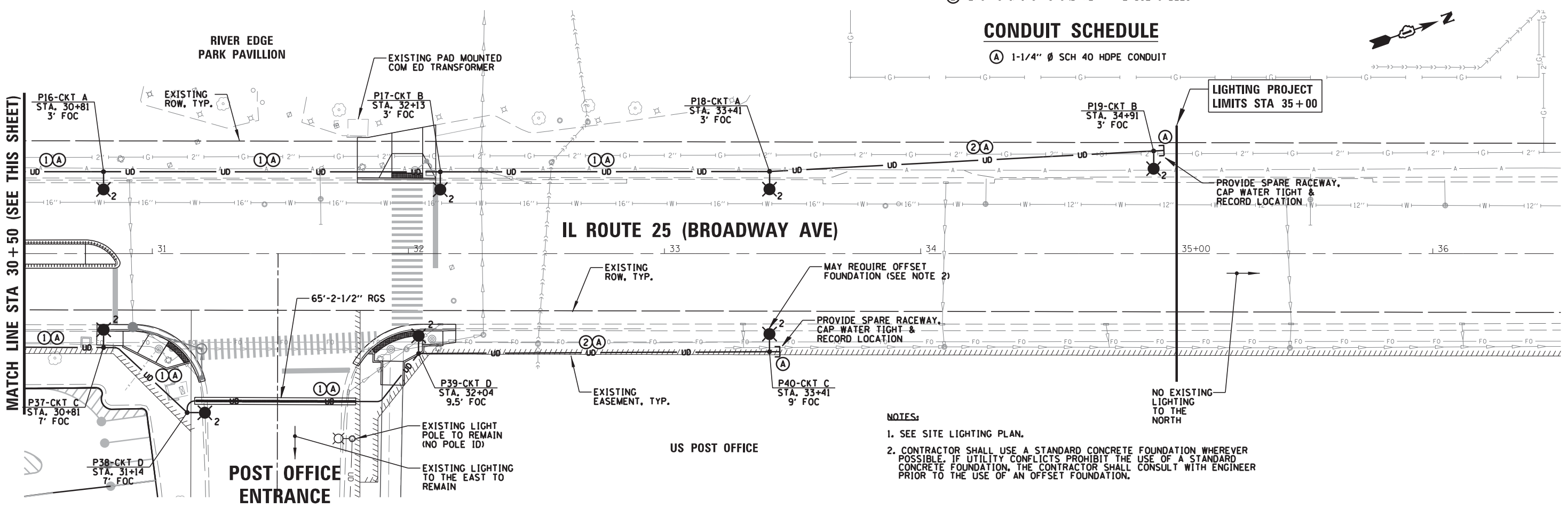

- NOTES:**
1. SEE SITE LIGHTING PLAN.
  2. CONTRACTOR SHALL USE A STANDARD CONCRETE FOUNDATION WHEREVER POSSIBLE. IF UTILITY CONFLICTS PROHIBIT THE USE OF A STANDARD CONCRETE FOUNDATION, THE CONTRACTOR SHALL CONSULT WITH ENGINEER PRIOR TO THE USE OF AN OFFSET FOUNDATION.

FILE NAME = N:\WBK\150077.2\Mech\LGT_150077.2.03.sht	USER NAME = adertico	DESIGNED - AJD	REVISED -	<b>STATE OF ILLINOIS DEPARTMENT OF TRANSPORTATION</b>	<b>AURORA TRANSIT CENTER IMPROVEMENTS ROADWAY LIGHTING PLAN (3 OF 3)</b>	F.A.U. RTE.	SECTION	COUNTY	TOTAL SHEETS	SHEET NO.	
Default	PLOT SCALE = 48"	CHECKED - AJD	REVISED -			2503	16-00313-00-MS	KANE	254	139	
	PLOT DATE = 10/16/2017	DATE - 10/16/2017	REVISED -			<b>CONTRACT NO. 61E18</b>					
						SCALE: N.T.S.	SHEET OF 254 SHEETS		STA. TO STA.	ILLINOIS FED. AID PROJECT	

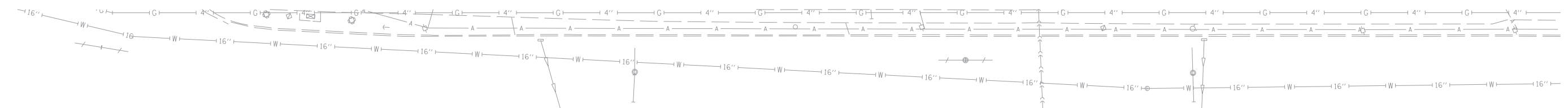
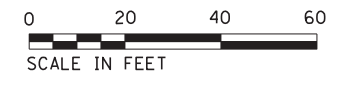

**BROADWAY AVE (IL 25)**

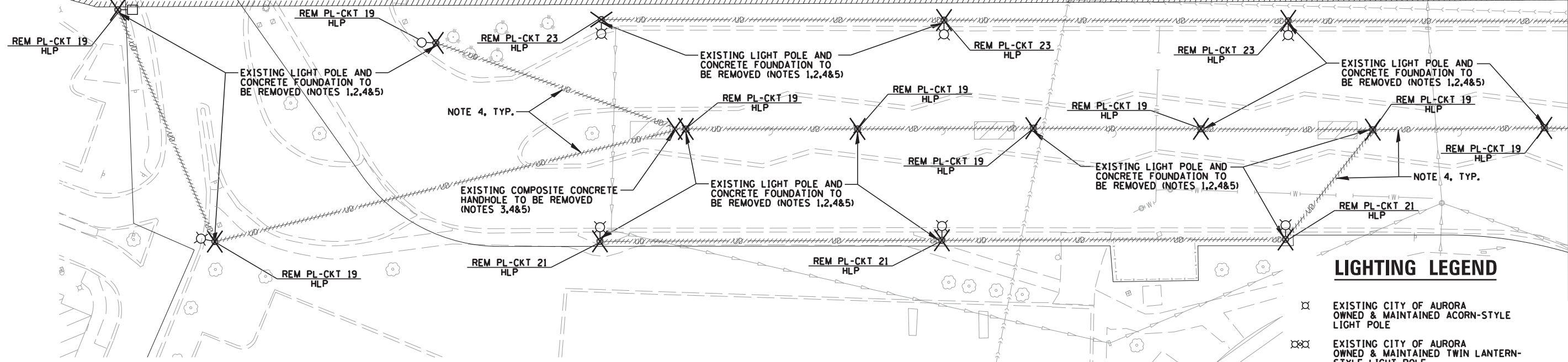

MATCH LINE SEE SHEET 141

**NOTES:**

1. CONTRACTOR SHALL REMOVE LIGHT POLES AT THE LOCATIONS SHOWN ON PLANS AND RETURN TO THE CITY OF AURORA PUBLIC WORKS. ALL ELECTRIC CABLES CONNECTED TO EXISTING LIGHT POLES SHALL BE DISCONNECTED AT POWER SOURCE AND ABANDONED IN THE CONDUIT.
2. EXISTING CONCRETE FOUNDATION SHALL BE REMOVED AND DISPOSED OF.
3. REMOVAL OF COMPOSITE HANDHOLE PAID FOR UNDER "REMOVE JUNCTION BOX", SEE SPECIAL PROVISION.
4. EXISTING CONDUIT & CABLES SHALL BE DISCONNECTED AND REMOVED TO 1 FT. BELOW GRADE AND ABANDONED IN ACCORDANCE WITH ARTICLE 842 OF THE STANDARD SPECIFICATIONS. THE CONTRACTOR MAY ELECT TO REMOVE EXISTING CABLES AND SALVAGE AT NO ADDITIONAL COST TO THE CONTRACT.
5. THE CONTRACTOR SHALL COORDINATE LIGHTING REMOVALS IN STAGES AS SHOWN IN PROPOSED CONSTRUCTION STAGING DRAWINGS. CONTRACTOR SHALL KEEP EXISTING LIGHTING OPERATIONAL IN EACH STAGE UNTIL PROPOSED LIGHTING INSTALLED IN THAT STAGE IS OPERATIONAL. MAINTAINING THE EXISTING LIGHTING SHALL BE PAID FOR UNDER "MAINTENANCE OF LIGHTING SYSTEM".

**LIGHTING LEGEND**

- EXISTING CITY OF AURORA OWNED & MAINTAINED ACORN-STYLE LIGHT POLE
- EXISTING CITY OF AURORA OWNED & MAINTAINED TWIN LANTERN-STYLE LIGHT POLE
- EXISTING CITY OF AURORA OWNED & MAINTAINED LANTERN-STYLE LIGHT POLE
- EXISTING CITY OF AURORA OWNED & MAINTAINED TWIN FLOOD LIGHT MOUNTED ON A 40 FT POLE
- EXISTING CITY OF AURORA OWNED & MAINTAINED LANTERN-STYLE LIGHT POLE
- EXISTING CITY OF AURORA OWNED & MAINTAINED TWIN PENDENT-STYLE LIGHT POLE
- EXISTING TO REMAIN REMOVE AND (SALVAGE OR RELOCATE)
- LIGHT POLE IDENTIFIER
- PARKING LOT LUMINAIRE CIRCUIT IDENTIFIER
- PANEL IDENTIFIER
- EXISTING PVC CONDUIT (SCH40 IN UNPAVED AREAS & SCH80 UNDER PAVED AREAS) FOR LIGHTING/ELECTRIC OR SECURITY CAMERAS
- EXISTING COMPOSITE CONCRETE HANDHOLE (SIZE AS SHOWN)
- EXISTING CONDUIT/WIRE TO BE ABANDONED

FILE NAME =	USER NAME = adericco	DESIGNED - AJD	REVISED -
N:\WBK\150077.2\Mech\RS\LG1-150077.2.01.sht		DRAWN - JRB	REVISED -
Default	PLOT SCALE = 48"	CHECKED - AJD	REVISED -
	PLOT DATE = 10/16/2017	DATE - 10/16/2017	REVISED -

**STATE OF ILLINOIS  
DEPARTMENT OF TRANSPORTATION**

**AURORA TRANSIT CENTER IMPROVEMENTS  
PARKING LOT LIGHTING REMOVAL PLAN (1 OF 4)**

SCALE: 48" SHEET OF 254 SHEETS STA. TO STA.

F.A.U. RTE.	SECTION	COUNTY	TOTAL SHEETS	SHEET NO.
2503	16-00313-00-MS	KANE	254	140
				CONTRACT NO. 61E18
ILLINOIS FED. AID PROJECT				



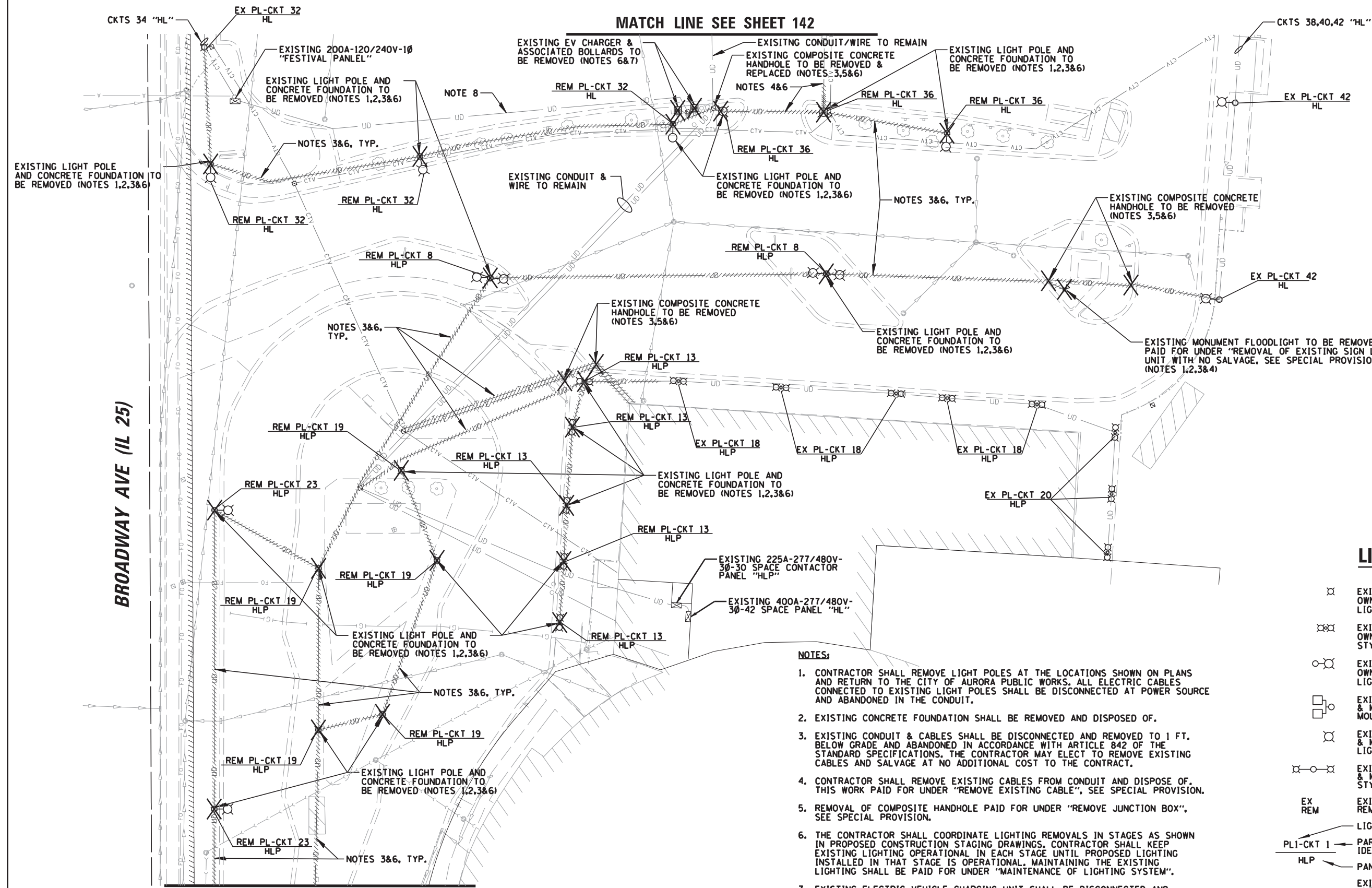

**LIGHTING LEGEND**

- EXISTING CITY OF AURORA OWNED & MAINTAINED ACORN-STYLE LIGHT POLE
- EXISTING CITY OF AURORA OWNED & MAINTAINED TWIN LANTERN-STYLE LIGHT POLE
- EXISTING CITY OF AURORA OWNED & MAINTAINED LANTERN-STYLE LIGHT POLE
- EXISTING CITY OF AURORA OWNED & MAINTAINED TWIN FLOOD LIGHT MOUNTED ON A 40 FT POLE
- EXISTING CITY OF AURORA OWNED & MAINTAINED LANTERN-STYLE LIGHT POLE
- EXISTING CITY OF AURORA OWNED & MAINTAINED PENDENT-STYLE LIGHT POLE
- EXISTING TO REMAIN REMOVE AND (SALVAGE OR RELOCATE) LIGHT POLE IDENTIFIER
- PL1-CKT 1 PARKING LOT LUMINAIRE CIRCUIT IDENTIFIER
- HLP PANEL IDENTIFIER
- UD EXISTING PVC CONDUIT (SCH40 IN UNPAVED AREAS & SCH80 UNDER PAVED AREAS) FOR LIGHTING/ELECTRIC OR SECURITY CAMERAS
- EXISTING COMPOSITE CONCRETE HANDHOLE (SIZE AS SHOWN)
- EXISTING CONDUIT/WIRE TO BE ABANDONED

**NOTES:**

1. CONTRACTOR SHALL REMOVE LIGHT POLES AT THE LOCATIONS SHOWN ON PLANS AND RETURN TO THE CITY OF AURORA PUBLIC WORKS. ALL ELECTRIC CABLES CONNECTED TO EXISTING LIGHT POLES SHALL BE DISCONNECTED AT POWER SOURCE AND ABANDONED IN THE CONDUIT.
2. EXISTING CONCRETE FOUNDATION SHALL BE REMOVED AND DISPOSED OF.
3. EXISTING CONDUIT & CABLES SHALL BE DISCONNECTED AND REMOVED TO 1 FT. BELOW GRADE AND ABANDONED IN ACCORDANCE WITH ARTICLE 842 OF THE STANDARD SPECIFICATIONS. THE CONTRACTOR MAY ELECT TO REMOVE EXISTING CABLES AND SALVAGE AT NO ADDITIONAL COST TO THE CONTRACT.
4. CONTRACTOR SHALL REMOVE EXISTING CABLES FROM CONDUIT AND DISPOSE OF. THIS WORK PAID FOR UNDER "REMOVE EXISTING CABLE", SEE SPECIAL PROVISION.
5. REMOVAL OF COMPOSITE HANDHOLE PAID FOR UNDER "REMOVE JUNCTION BOX", SEE SPECIAL PROVISION.
6. THE CONTRACTOR SHALL COORDINATE LIGHTING REMOVALS IN STAGES AS SHOWN IN PROPOSED CONSTRUCTION STAGING DRAWINGS. CONTRACTOR SHALL KEEP EXISTING LIGHTING OPERATIONAL IN EACH STAGE UNTIL PROPOSED LIGHTING INSTALLED IN THAT STAGE IS OPERATIONAL, MAINTAINING THE EXISTING LIGHTING SHALL BE PAID FOR UNDER "MAINTENANCE OF LIGHTING SYSTEM".
7. EXISTING ELECTRIC VEHICLE CHARGING UNIT SHALL BE DISCONNECTED AND RETURNED TO THE CITY OF AURORA PUBLIC WORKS. THIS WORK PAID FOR UNDER "ELECTRICAL EQUIPMENT REMOVAL AND SALVAGE", SEE SPECIAL PROVISION.
8. EXISTING UNDERGROUND WIRING FOR EV CHARGERS SHALL BE LEFT IN PLACE FOR THE CITY TO REUSE.

FILE NAME =	USER NAME = adericco	DESIGNED - AJD	REVISED -	<b>STATE OF ILLINOIS DEPARTMENT OF TRANSPORTATION</b>	<b>AURORA TRANSIT CENTER IMPROVEMENTS PARKING LOT LIGHTING REMOVAL PLAN (2 OF 4)</b>	F.A.U. RTE.	SECTION	COUNTY	TOTAL SHEETS	SHEET NO.	
N:\WBK\150077.2\Mech\RS\LG1-150077.2.02.sht	PLOT SCALE = 48"	DRAWN - JRB	REVISED -			2503	16-00313-00-MS	KANE	254	141	
Default	PLOT DATE = 10/16/2017	CHECKED - AJD	REVISED -			<b>CONTRACT NO. 61E18</b>					
		DATE - 10/16/2017	REVISED -			ILLINOIS FED. AID PROJECT					

SCALE: 48" SHEET OF 254 SHEETS STA. TO STA.

MATCH LINE SEE SHEET 143

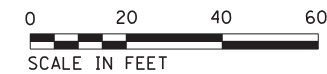
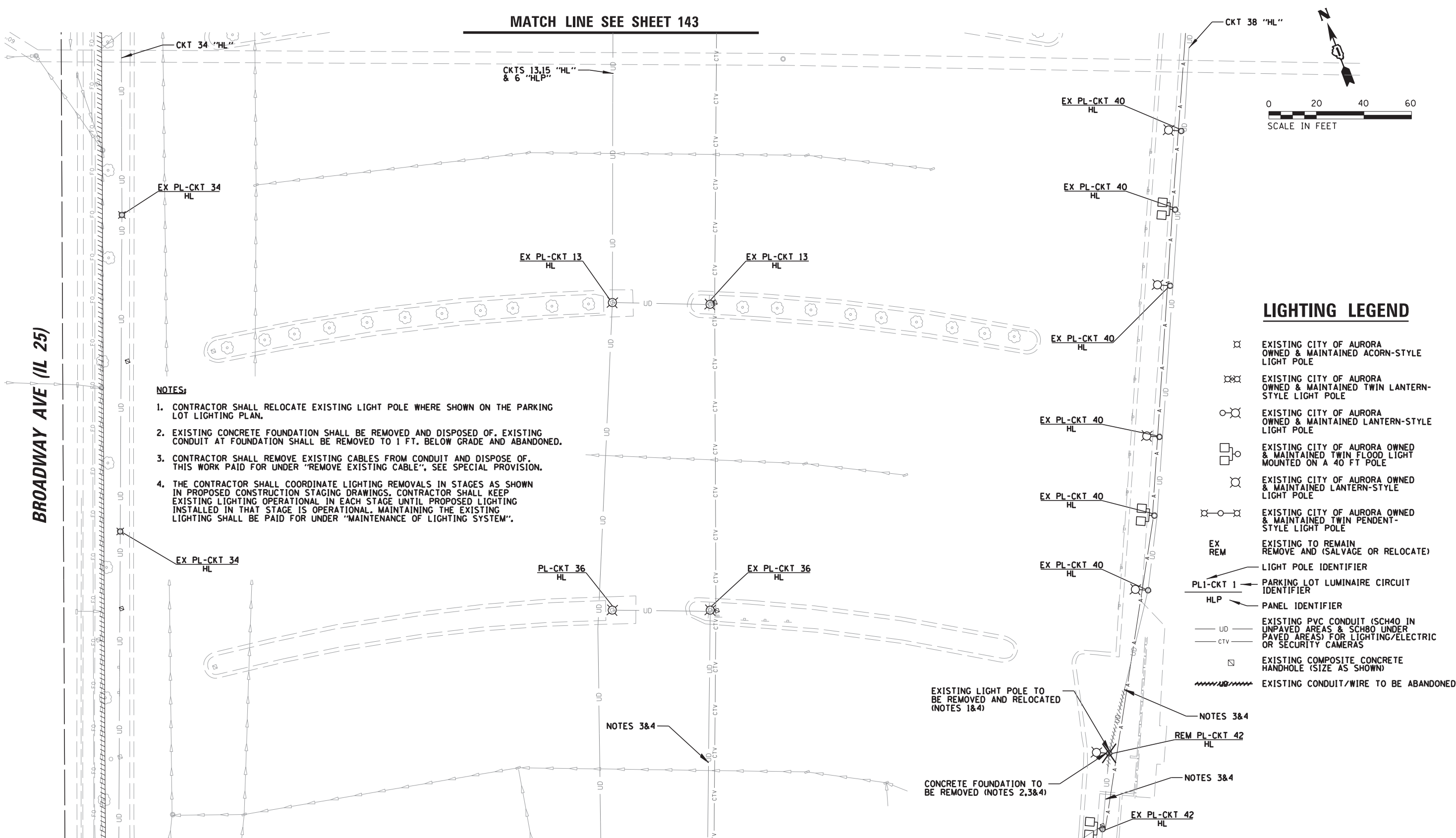

**LIGHTING LEGEND**

- EXISTING CITY OF AURORA OWNED & MAINTAINED ACORN-STYLE LIGHT POLE
- EXISTING CITY OF AURORA OWNED & MAINTAINED TWIN LANTERN-STYLE LIGHT POLE
- EXISTING CITY OF AURORA OWNED & MAINTAINED LANTERN-STYLE LIGHT POLE
- EXISTING CITY OF AURORA OWNED & MAINTAINED TWIN FLOOD LIGHT MOUNTED ON A 40 FT POLE
- EXISTING CITY OF AURORA OWNED & MAINTAINED LANTERN-STYLE LIGHT POLE
- EXISTING CITY OF AURORA OWNED & MAINTAINED PENDENT-STYLE LIGHT POLE
- EX REM EXISTING TO REMAIN REMOVE AND (SALVAGE OR RELOCATE)
- LIGHT POLE IDENTIFIER
- PL1-CKT 1 PARKING LOT LUMINAIRE CIRCUIT IDENTIFIER
- HLP PANEL IDENTIFIER
- UD EXISTING PVC CONDUIT (SCH40 IN UNPAVED AREAS & SCH80 UNDER PAVED AREAS) FOR LIGHTING/ELECTRIC OR SECURITY CAMERAS
- CTV EXISTING PVC CONDUIT (SCH40 IN UNPAVED AREAS & SCH80 UNDER PAVED AREAS) FOR LIGHTING/ELECTRIC OR SECURITY CAMERAS
- EXISTING COMPOSITE CONCRETE HANDHOLE (SIZE AS SHOWN)
- EXISTING CONDUIT/WIRE TO BE ABANDONED

- NOTES:**
- CONTRACTOR SHALL RELOCATE EXISTING LIGHT POLE WHERE SHOWN ON THE PARKING LOT LIGHTING PLAN.
  - EXISTING CONCRETE FOUNDATION SHALL BE REMOVED AND DISPOSED OF. EXISTING CONDUIT AT FOUNDATION SHALL BE REMOVED TO 1 FT. BELOW GRADE AND ABANDONED.
  - CONTRACTOR SHALL REMOVE EXISTING CABLES FROM CONDUIT AND DISPOSE OF. THIS WORK PAID FOR UNDER "REMOVE EXISTING CABLE", SEE SPECIAL PROVISION.
  - THE CONTRACTOR SHALL COORDINATE LIGHTING REMOVALS IN STAGES AS SHOWN IN PROPOSED CONSTRUCTION STAGING DRAWINGS. CONTRACTOR SHALL KEEP EXISTING LIGHTING OPERATIONAL IN EACH STAGE UNTIL PROPOSED LIGHTING INSTALLED IN THAT STAGE IS OPERATIONAL. MAINTAINING THE EXISTING LIGHTING SHALL BE PAID FOR UNDER "MAINTENANCE OF LIGHTING SYSTEM".

EXISTING LIGHT POLE TO BE REMOVED AND RELOCATED (NOTES 1&4)

CONCRETE FOUNDATION TO BE REMOVED (NOTES 2,3&4)

NOTES 3&4

NOTES 3&4

NOTES 3&4

MATCH LINE SEE SHEET 141

FILE NAME = N:\WBK\150077.2\Mech\RSLGT-150077.2_03.sht	USER NAME = odericco	DESIGNED - AJD	REVISED -	<b>STATE OF ILLINOIS DEPARTMENT OF TRANSPORTATION</b>	<b>AURORA TRANSIT CENTER IMPROVEMENTS PARKING LOT LIGHTING REMOVAL PLAN (3 OF 4)</b>	F.A.U. RTE. 2503	SECTION 16-00313-00-MS	COUNTY KANE	TOTAL SHEETS 254	SHEET NO. 142		
Default	PLOT SCALE = 48"	CHECKED - AJD	REVISED -			SCALE: 48"	SHEET OF 254 SHEETS	STA. TO STA.	CONTRACT NO. 61E18			
	PLOT DATE = 10/16/2017	DATE - 10/16/2017	REVISED -			ILLINOIS FED. AID PROJECT						

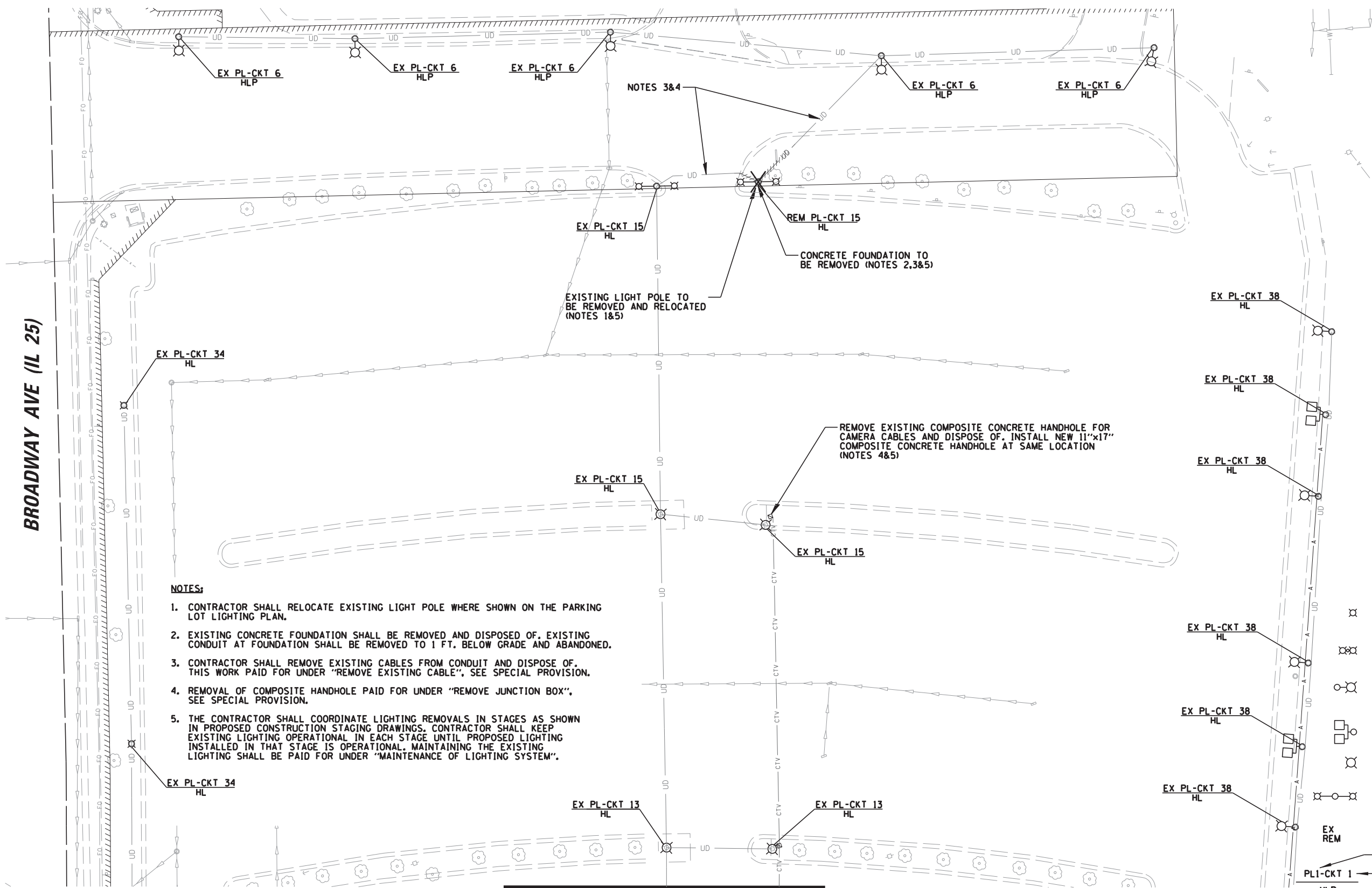
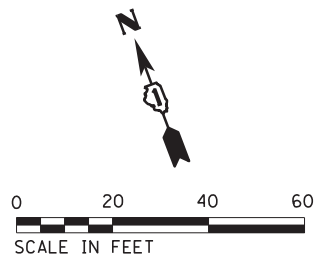

**NOTES:**

1. CONTRACTOR SHALL RELOCATE EXISTING LIGHT POLE WHERE SHOWN ON THE PARKING LOT LIGHTING PLAN.
2. EXISTING CONCRETE FOUNDATION SHALL BE REMOVED AND DISPOSED OF. EXISTING CONDUIT AT FOUNDATION SHALL BE REMOVED TO 1 FT. BELOW GRADE AND ABANDONED.
3. CONTRACTOR SHALL REMOVE EXISTING CABLES FROM CONDUIT AND DISPOSE OF. THIS WORK PAID FOR UNDER "REMOVE EXISTING CABLE", SEE SPECIAL PROVISION.
4. REMOVAL OF COMPOSITE HANDHOLE PAID FOR UNDER "REMOVE JUNCTION BOX". SEE SPECIAL PROVISION.
5. THE CONTRACTOR SHALL COORDINATE LIGHTING REMOVALS IN STAGES AS SHOWN IN PROPOSED CONSTRUCTION STAGING DRAWINGS. CONTRACTOR SHALL KEEP EXISTING LIGHTING OPERATIONAL IN EACH STAGE UNTIL PROPOSED LIGHTING INSTALLED IN THAT STAGE IS OPERATIONAL. MAINTAINING THE EXISTING LIGHTING SHALL BE PAID FOR UNDER "MAINTENANCE OF LIGHTING SYSTEM".

**MATCH LINE SEE SHEET 142**

**LIGHTING LEGEND**

- ⊗ EXISTING CITY OF AURORA OWNED & MAINTAINED ACORN-STYLE LIGHT POLE
- ⊗⊗ EXISTING CITY OF AURORA OWNED & MAINTAINED TWIN LANTERN-STYLE LIGHT POLE
- ⊗ EXISTING CITY OF AURORA OWNED & MAINTAINED LANTERN-STYLE LIGHT POLE
- ⊗ EXISTING CITY OF AURORA OWNED & MAINTAINED TWIN FLOOD LIGHT MOUNTED ON A 40 FT POLE
- ⊗ EXISTING CITY OF AURORA OWNED & MAINTAINED LANTERN-STYLE LIGHT POLE
- ⊗ EXISTING CITY OF AURORA OWNED & MAINTAINED TWIN PENDENT-STYLE LIGHT POLE
- EX REM EXISTING TO REMAIN REMOVE AND (SALVAGE OR RELOCATE)
- ⊗ LIGHT POLE IDENTIFIER
- PL1-CKT 1 PARKING LOT LUMINAIRE CIRCUIT IDENTIFIER
- HLP PANEL IDENTIFIER
- UD — EXISTING PVC CONDUIT (SCH40 IN UNPAVED AREAS & SCH80 UNDER PAVED AREAS) FOR LIGHTING/ELECTRIC OR SECURITY CAMERAS
- CTV — EXISTING COMPOSITE CONCRETE HANDHOLE (SIZE AS SHOWN)
- ⊗ EXISTING CONDUIT/WIRE TO BE ABANDONED

FILE NAME =	USER NAME = adericco	DESIGNED - AJD	REVISED -
N:\WBK\150077.2\Mech\RLS\LT-150077.2_04.sht		DRAWN - JRB	REVISED -
Default		CHECKED - AJD	REVISED -
	PLOT DATE = 10/16/2017	DATE - 10/16/2017	REVISED -

**STATE OF ILLINOIS  
DEPARTMENT OF TRANSPORTATION**

**AURORA TRANSIT CENTER IMPROVEMENTS  
PARKING LOT LIGHTING REMOVAL PLAN (4 OF 4)**

SCALE: 40' SHEET OF 254 SHEETS STA. TO STA.

F.A.U. RTE.	SECTION	COUNTY	TOTAL SHEETS	SHEET NO.
2503	16-00313-00-MS	KANE	254	143
CONTRACT NO. 61E18				
ILLINOIS FED. AID PROJECT				

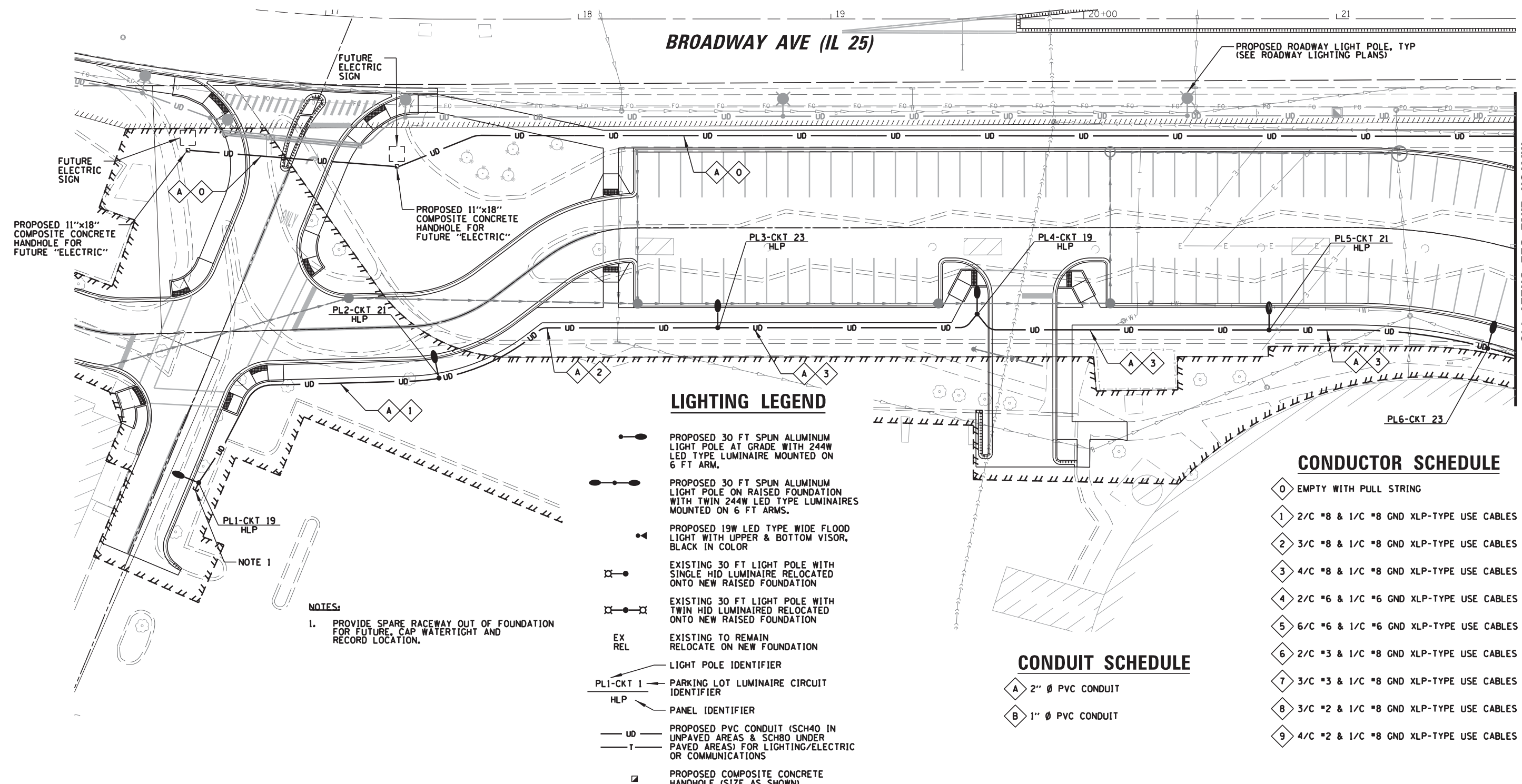
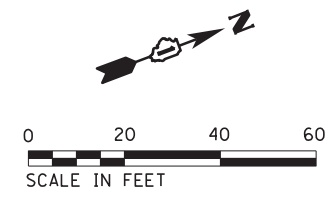

**BROADWAY AVE (IL 25)**

**LIGHTING LEGEND**

- PROPOSED 30 FT SPUN ALUMINUM LIGHT POLE AT GRADE WITH 244W LED TYPE LUMINAIRE MOUNTED ON 6 FT ARM.
- PROPOSED 30 FT SPUN ALUMINUM LIGHT POLE ON RAISED FOUNDATION WITH TWIN 244W LED TYPE LUMINAIRES MOUNTED ON 6 FT ARMS.
- PROPOSED 19W LED TYPE WIDE FLOOD LIGHT WITH UPPER & BOTTOM VISOR, BLACK IN COLOR.
- EXISTING 30 FT LIGHT POLE WITH SINGLE HID LUMINAIRE RELOCATED ONTO NEW RAISED FOUNDATION
- EXISTING 30 FT LIGHT POLE WITH TWIN HID LUMINAIRE RELOCATED ONTO NEW RAISED FOUNDATION
- EXISTING TO REMAIN
- RELOCATE ON NEW FOUNDATION
- LIGHT POLE IDENTIFIER
- PARKING LOT LUMINAIRE CIRCUIT IDENTIFIER
- PANEL IDENTIFIER
- PROPOSED PVC CONDUIT (SCH40 IN UNPAVED AREAS & SCH80 UNDER PAVED AREAS) FOR LIGHTING/ELECTRIC OR COMMUNICATIONS
- PROPOSED COMPOSITE CONCRETE HANDHOLE (SIZE AS SHOWN)

**CONDUCTOR SCHEDULE**

- 0 EMPTY WITH PULL STRING
- 1 2/C #8 & 1/C #8 GND XLP-TYPE USE CABLES
- 2 3/C #8 & 1/C #8 GND XLP-TYPE USE CABLES
- 3 4/C #8 & 1/C #8 GND XLP-TYPE USE CABLES
- 4 2/C #6 & 1/C #6 GND XLP-TYPE USE CABLES
- 5 6/C #6 & 1/C #6 GND XLP-TYPE USE CABLES
- 6 2/C #3 & 1/C #8 GND XLP-TYPE USE CABLES
- 7 3/C #3 & 1/C #8 GND XLP-TYPE USE CABLES
- 8 3/C #2 & 1/C #8 GND XLP-TYPE USE CABLES
- 9 4/C #2 & 1/C #8 GND XLP-TYPE USE CABLES

**CONDUIT SCHEDULE**

- A 2" Ø PVC CONDUIT
- B 1" Ø PVC CONDUIT

**NOTES:**  
 1. PROVIDE SPARE RACEWAY OUT OF FOUNDATION FOR FUTURE, CAP WATERTIGHT AND RECORD LOCATION.

MATCH LINE SEE SHEET 145

FILE NAME = N:\WBK\150077.2\Mech\SLGT-150077.2.01.sh	USER NAME = odericco	DESIGNED - AJD	REVISED -	<b>STATE OF ILLINOIS DEPARTMENT OF TRANSPORTATION</b>	<b>AURORA TRANSIT CENTER IMPROVEMENTS PARKING LOT LIGHTING PLAN (1 OF 4)</b>	F.A.U. RTE. 2503	SECTION 16-00313-00-MS	COUNTY KANE	TOTAL SHEETS 254	SHEET NO. 144	
Default	PLOT SCALE = 48"	CHECKED - AJD	REVISED -			SCALE: 48"	SHEET OF 254 SHEETS	STA. TO STA.	CONTRACT NO. 61E18		
	PLOT DATE = 10/16/2017	DATE - 10/16/2017	REVISED -			ILLINOIS FED. AID PROJECT					

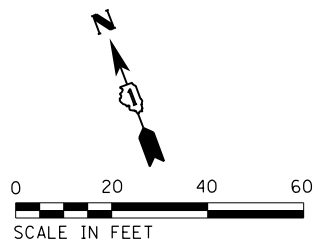

MATCH LINE SEE SHEET 146

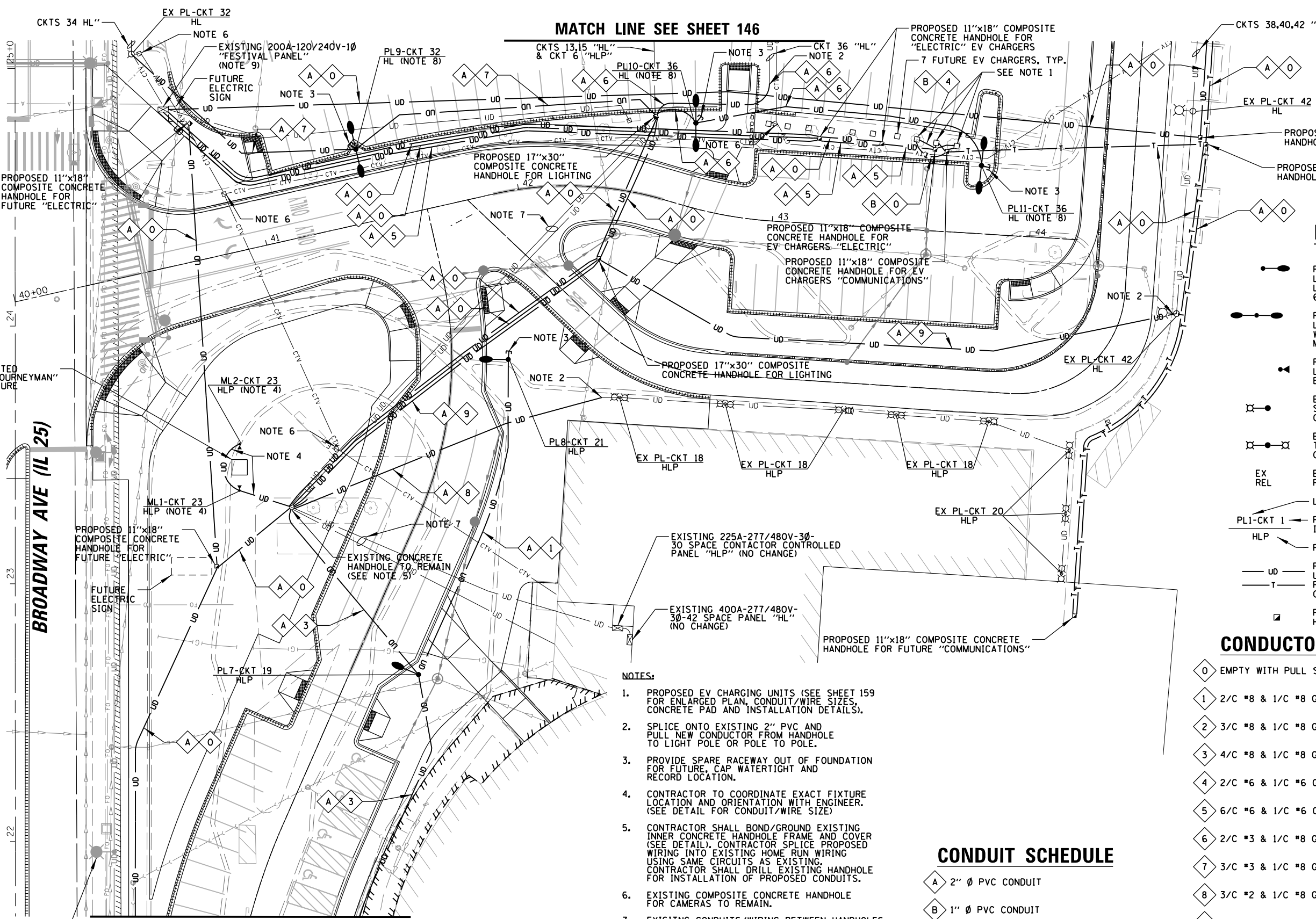

**LIGHTING LEGEND**

- PROPOSED 30 FT SPUN ALUMINUM LIGHT POLE AT GRADE WITH 244W LED TYPE LUMINAIRE MOUNTED ON 6 FT ARM.
- PROPOSED 30 FT SPUN ALUMINUM LIGHT POLE ON RAISED FOUNDATION WITH TWIN 244W LED TYPE LUMINAIRES MOUNTED ON 6 FT ARMS.
- PROPOSED 19W LED TYPE WIDE FLOOD LIGHT WITH UPPER & BOTTOM VISOR, BLACK IN COLOR
- EXISTING 30 FT LIGHT POLE WITH SINGLE HID LUMINAIRE RELOCATED ONTO NEW RAISED FOUNDATION
- EXISTING 30 FT LIGHT POLE WITH TWIN HID LUMINAIRES RELOCATED ONTO NEW RAISED FOUNDATION
- EX REL EXISTING TO REMAIN RELOCATE ON NEW FOUNDATION
- LIGHT POLE IDENTIFIER
- PL1-CKT 1 PARKING LOT LUMINAIRE CIRCUIT IDENTIFIER
- HLP PANEL IDENTIFIER
- UD PROPOSED PVC CONDUIT (SCH40 IN UNPAVED AREAS & SCH80 UNDER PAVED AREAS) FOR LIGHTING/ELECTRIC OR COMMUNICATIONS
- PROPOSED COMPOSITE CONCRETE HANDHOLE (SIZE AS SHOWN)

**CONDUCTOR SCHEDULE**

- 0 EMPTY WITH PULL STRING
- 1 2/C #8 & 1/C #8 GND XLP-TYPE USE CABLES
- 2 3/C #8 & 1/C #8 GND XLP-TYPE USE CABLES
- 3 4/C #8 & 1/C #8 GND XLP-TYPE USE CABLES
- 4 2/C #6 & 1/C #6 GND XLP-TYPE USE CABLES
- 5 6/C #6 & 1/C #6 GND XLP-TYPE USE CABLES
- 6 2/C #3 & 1/C #8 GND XLP-TYPE USE CABLES
- 7 3/C #3 & 1/C #8 GND XLP-TYPE USE CABLES
- 8 3/C #2 & 1/C #8 GND XLP-TYPE USE CABLES
- 9 4/C #2 & 1/C #8 GND XLP-TYPE USE CABLES

**CONDUIT SCHEDULE**

- A 2" Ø PVC CONDUIT
- B 1" Ø PVC CONDUIT

- NOTES:**
1. PROPOSED EV CHARGING UNITS (SEE SHEET 159 FOR ENLARGED PLAN, CONDUIT/WIRE SIZES, CONCRETE PAD AND INSTALLATION DETAILS).
  2. SPLICE ONTO EXISTING 2" PVC AND PULL NEW CONDUCTOR FROM HANDHOLE TO LIGHT POLE OR POLE TO POLE.
  3. PROVIDE SPARE RACEWAY OUT OF FOUNDATION FOR FUTURE, CAP WATERTIGHT AND RECORD LOCATION.
  4. CONTRACTOR TO COORDINATE EXACT FIXTURE LOCATION AND ORIENTATION WITH ENGINEER. (SEE DETAIL FOR CONDUIT/WIRE SIZE)
  5. CONTRACTOR SHALL BOND/GROUND EXISTING INNER CONCRETE HANDHOLE FRAME AND COVER (SEE DETAIL). CONTRACTOR SPLICE PROPOSED WIRING INTO EXISTING HOME RUN WIRING USING SAME CIRCUITS AS EXISTING. CONTRACTOR SHALL DRILL EXISTING HANDHOLE FOR INSTALLATION OF PROPOSED CONDUITS.
  6. EXISTING COMPOSITE CONCRETE HANDHOLE FOR CAMERAS TO REMAIN.
  7. EXISTING CONDUITS/WIRING BETWEEN HANDHOLES TO REMAIN.
  8. PROPOSED LIGHT POLE LOCATION IS DESIGNED TO EXPAND CONDUIT NORTH FOR FUTURE PARKING LOT LIGHTING IMPROVEMENTS.
  9. MODIFY EXISTING FESTIVAL PANEL TO ACCOMMODATE PROPOSED EV CHARGERS (SEE DETAIL)

MATCH LINE SEE SHEET 144

FILE NAME =	USER NAME = bweich	DESIGNED - AJD	REVISED -	<b>STATE OF ILLINOIS DEPARTMENT OF TRANSPORTATION</b>	<b>AURORA TRANSIT CENTER IMPROVEMENTS PARKING LOT LIGHTING PLAN (2 OF 4)</b>	F.A.U. R.T.E.	SECTION	COUNTY	TOTAL SHEETS	SHEET NO.
N:\WBK\150077.2\Mech\SLGT-150077.2.02.sh	PLOT SCALE = 48"	DRAWN - JRB	REVISED -			2503	16-00313-00-MS	KANE	254	145
Default	PLOT DATE = 12/4/2017	CHECKED - AJD	REVISED -			CONTRACT NO. 61E18				
				SCALE: 48"	SHEET OF 254 SHEETS	STA. TO STA.	ILLINOIS FED. AID PROJECT			

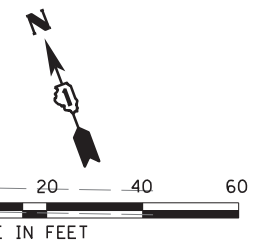

MATCH LINE SEE SHEET 147

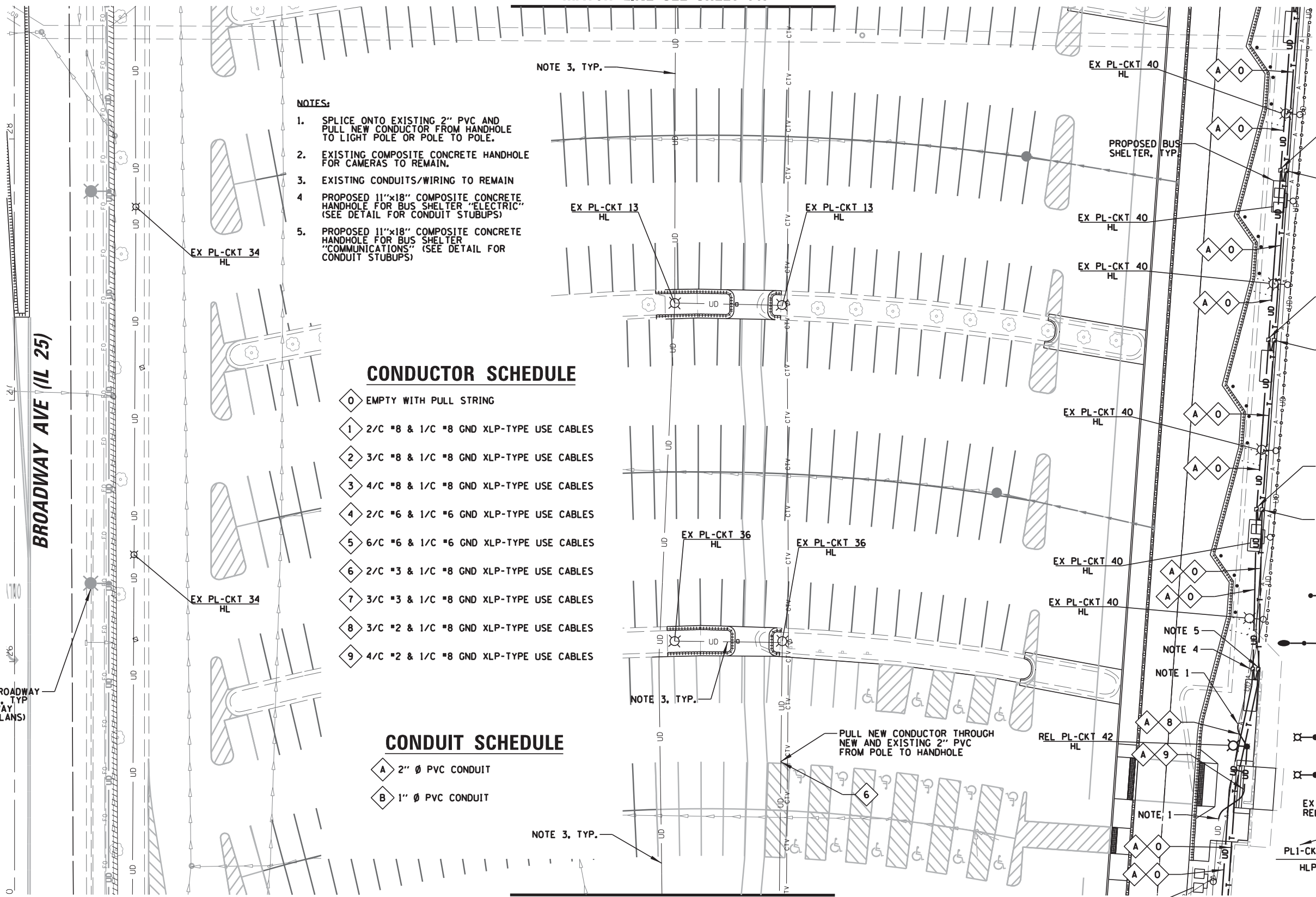

- NOTES:**
1. SPLICE ONTO EXISTING 2" PVC AND PULL NEW CONDUCTOR FROM HANDHOLE TO LIGHT POLE OR POLE TO POLE.
  2. EXISTING COMPOSITE CONCRETE HANDHOLE FOR CAMERAS TO REMAIN.
  3. EXISTING CONDUITS/WIRING TO REMAIN
  4. PROPOSED 11"x18" COMPOSITE CONCRETE HANDHOLE FOR BUS SHELTER "ELECTRIC" (SEE DETAIL FOR CONDUIT STUBUPS)
  5. PROPOSED 11"x18" COMPOSITE CONCRETE HANDHOLE FOR BUS SHELTER "COMMUNICATIONS" (SEE DETAIL FOR CONDUIT STUBUPS)

**CONDUCTOR SCHEDULE**

- 0 EMPTY WITH PULL STRING
- 1 2/C #8 & 1/C #8 GND XLP-TYPE USE CABLES
- 2 3/C #8 & 1/C #8 GND XLP-TYPE USE CABLES
- 3 4/C #8 & 1/C #8 GND XLP-TYPE USE CABLES
- 4 2/C #6 & 1/C #6 GND XLP-TYPE USE CABLES
- 5 6/C #6 & 1/C #6 GND XLP-TYPE USE CABLES
- 6 2/C #3 & 1/C #8 GND XLP-TYPE USE CABLES
- 7 3/C #3 & 1/C #8 GND XLP-TYPE USE CABLES
- 8 3/C #2 & 1/C #8 GND XLP-TYPE USE CABLES
- 9 4/C #2 & 1/C #8 GND XLP-TYPE USE CABLES

**CONDUIT SCHEDULE**

- A 2" Ø PVC CONDUIT
- B 1" Ø PVC CONDUIT

**LIGHTING LEGEND**

- PROPOSED 30 FT SPUN ALUMINUM LIGHT POLE AT GRADE WITH 244W LED TYPE LUMINAIRE MOUNTED ON 6 FT ARM.
- PROPOSED 30 FT SPUN ALUMINUM LIGHT POLE ON RAISED FOUNDATION WITH TWIN 244W LED TYPE LUMINAIRES MOUNTED ON 6 FT ARMS.
- PROPOSED 19W LED TYPE WIDE FLOOD LIGHT WITH UPPER & BOTTOM VISOR, BLACK IN COLOR
- EXISTING 30 FT LIGHT POLE WITH SINGLE HID LUMINAIRE RELOCATED ONTO NEW RAISED FOUNDATION
- EXISTING 30 FT LIGHT POLE WITH TWIN HID LUMINAIRES RELOCATED ONTO NEW RAISED FOUNDATION
- EXISTING TO REMAIN RELOCATE ON NEW FOUNDATION
- LIGHT POLE IDENTIFIER
- PL1-CKT 1 - PARKING LOT LUMINAIRE CIRCUIT IDENTIFIER
- HLP - PANEL IDENTIFIER
- UD - PROPOSED PVC CONDUIT (SCH40 IN UNPAVED AREAS & SCH80 UNDER PAVED AREAS) FOR LIGHTING/ELECTRIC OR COMMUNICATIONS
- PROPOSED COMPOSITE CONCRETE HANDHOLE (SIZE AS SHOWN)

PROPOSED ROADWAY LIGHT POLE, TYP (SEE ROADWAY LIGHTING PLANS)

MATCH LINE SEE SHEET 145

FILE NAME =	USER NAME = adericco	DESIGNED - AJD	REVISED -	<b>STATE OF ILLINOIS DEPARTMENT OF TRANSPORTATION</b>	<b>AURORA TRANSIT CENTER IMPROVEMENTS PARKING LOT LIGHTING PLAN (3 OF 4)</b>	F.A.U. RTE.	SECTION	COUNTY	TOTAL SHEETS	SHEET NO.
N:\WBK\150077.2\Mech\SLGT-150077.2.03.sh	PLOT SCALE = 48"	DRAWN - JRB	REVISED -			2503	16-00313-00-MS	KANE	254	146
Default	PLOT DATE = 10/16/2017	CHECKED - AJD	REVISED -			CONTRACT NO. 61E18				
		DATE - 10/16/2017	REVISED -			ILLINOIS FED. AID PROJECT				

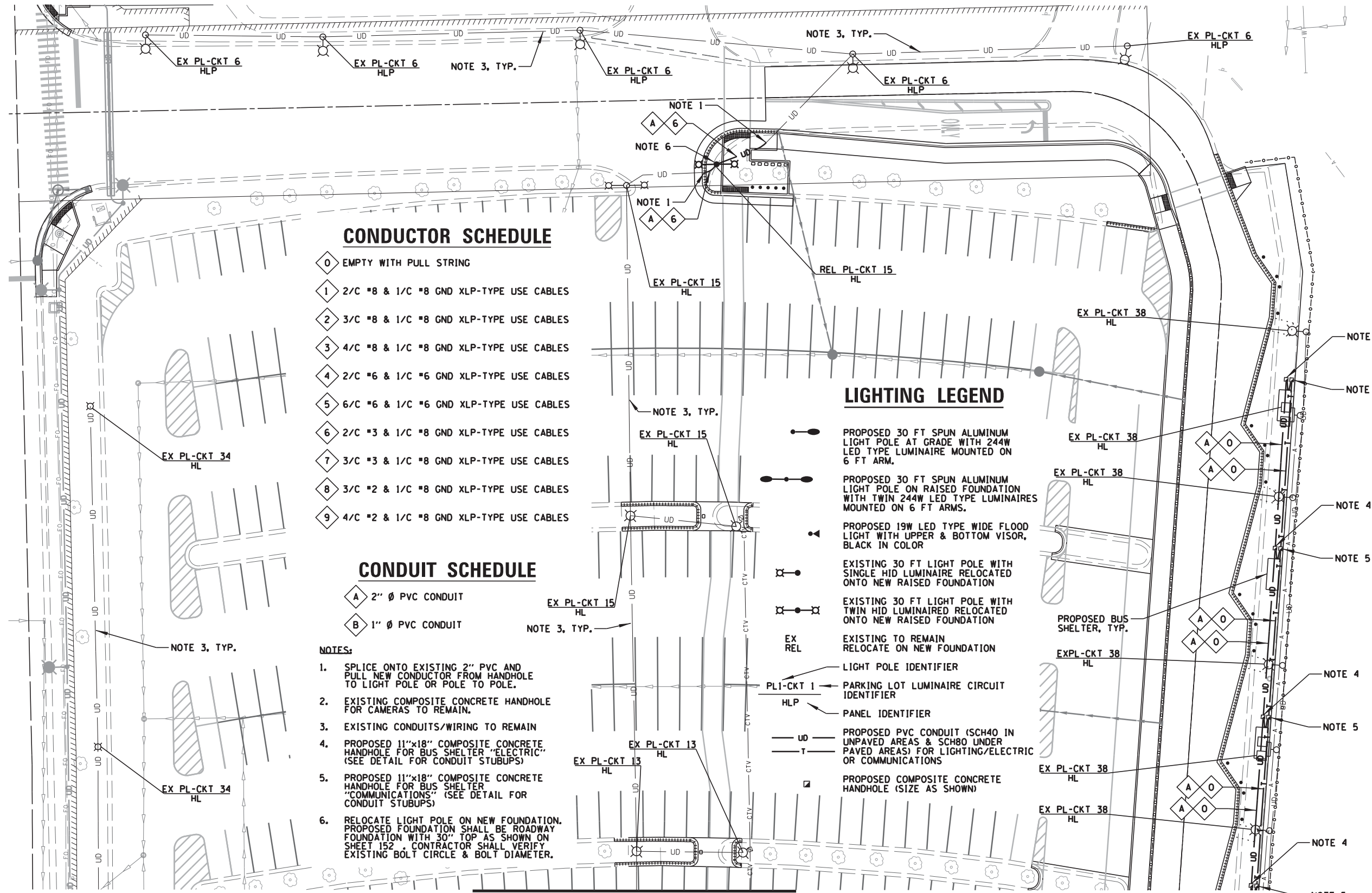
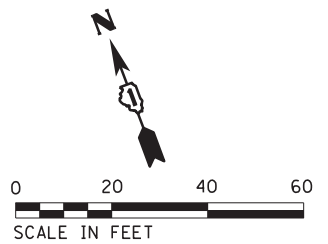

**CONDUCTOR SCHEDULE**

- 0 EMPTY WITH PULL STRING
- 1 2/C #8 & 1/C #8 GND XLP-TYPE USE CABLES
- 2 3/C #8 & 1/C #8 GND XLP-TYPE USE CABLES
- 3 4/C #8 & 1/C #8 GND XLP-TYPE USE CABLES
- 4 2/C #6 & 1/C #6 GND XLP-TYPE USE CABLES
- 5 6/C #6 & 1/C #6 GND XLP-TYPE USE CABLES
- 6 2/C #3 & 1/C #8 GND XLP-TYPE USE CABLES
- 7 3/C #3 & 1/C #8 GND XLP-TYPE USE CABLES
- 8 3/C #2 & 1/C #8 GND XLP-TYPE USE CABLES
- 9 4/C #2 & 1/C #8 GND XLP-TYPE USE CABLES

**CONDUIT SCHEDULE**

- A 2" Ø PVC CONDUIT
- B 1" Ø PVC CONDUIT

**NOTES:**

1. SPLICE ONTO EXISTING 2" PVC AND PULL NEW CONDUCTOR FROM HANDHOLE TO LIGHT POLE OR POLE TO POLE.
2. EXISTING COMPOSITE CONCRETE HANDHOLE FOR CAMERAS TO REMAIN.
3. EXISTING CONDUITS/WIRING TO REMAIN
4. PROPOSED 11"x18" COMPOSITE CONCRETE HANDHOLE FOR BUS SHELTER "ELECTRIC" (SEE DETAIL FOR CONDUIT STUBUPS)
5. PROPOSED 11"x18" COMPOSITE CONCRETE HANDHOLE FOR BUS SHELTER "COMMUNICATIONS" (SEE DETAIL FOR CONDUIT STUBUPS)
6. RELOCATE LIGHT POLE ON NEW FOUNDATION. PROPOSED FOUNDATION SHALL BE ROADWAY FOUNDATION WITH 30" TOP AS SHOWN ON SHEET 152. CONTRACTOR SHALL VERIFY EXISTING BOLT CIRCLE & BOLT DIAMETER.

**LIGHTING LEGEND**

- PROPOSED 30 FT SPUN ALUMINUM LIGHT POLE AT GRADE WITH 244W LED TYPE LUMINAIRE MOUNTED ON 6 FT ARM.
- PROPOSED 30 FT SPUN ALUMINUM LIGHT POLE ON RAISED FOUNDATION WITH TWIN 244W LED TYPE LUMINAIRES MOUNTED ON 6 FT ARMS.
- ◐ PROPOSED 19W LED TYPE WIDE FLOOD LIGHT WITH UPPER & BOTTOM VISOR, BLACK IN COLOR
- ◑ EXISTING 30 FT LIGHT POLE WITH SINGLE HID LUMINAIRE RELOCATED ONTO NEW RAISED FOUNDATION
- ◒ EXISTING 30 FT LIGHT POLE WITH TWIN HID LUMINAIRE RELOCATED ONTO NEW RAISED FOUNDATION
- EX REL EXISTING TO REMAIN RELOCATE ON NEW FOUNDATION
- LIGHT POLE IDENTIFIER
- PLI-CKT 1 PARKING LOT LUMINAIRE CIRCUIT IDENTIFIER
- HLP PANEL IDENTIFIER
- UD PROPOSED PVC CONDUIT (SCH40 IN UNPAVED AREAS & SCH80 UNDER PAVED AREAS) FOR LIGHTING/ELECTRIC OR COMMUNICATIONS
- T
- PROPOSED COMPOSITE CONCRETE HANDHOLE (SIZE AS SHOWN)

MATCH LINE SEE SHEET 146

FILE NAME =	USER NAME = adericco	DESIGNED -	REVISED -	<b>STATE OF ILLINOIS DEPARTMENT OF TRANSPORTATION</b>	<b>AURORA TRANSIT CENTER IMPROVEMENTS PARKING LOT LIGHTING PLAN (4 OF 4)</b>	F.A.U. RTE.	SECTION	COUNTY	TOTAL SHEETS	SHEET NO.	
N:\WBK\150077.2\Mech\SLGT-150077.2.04.sh	PLOT SCALE = 48"	DRAWN -	REVISED -			2503	16-00313-00-MS	KANE	254	147	
Default	PLOT DATE = 10/16/2017	CHE@BDD -	REVISED -			<b>CONTRACT NO. 61E18</b>					
		DATE - 10/16/2017	REVISED -			ILLINOIS FED. AID PROJECT					

ITEM	SPECIFICATION
① MAIN CIRCUIT BREAKER	100 AMPERE, 2P, 240V SERVICE RATING, 22KAIC
② LAMPHOLDER CIRCUIT BREAKER	20 AMPERE, 1P, 120V RATING, 22KAIC
③ PHOTOELECTRIC CONTROL CIRCUIT BREAKER	15 AMPERE, 1P, 120V RATING, 22KAIC
④ AUXILIARY RELAY	120 V OPERATED DPDT 60 HZ COIL 2 NO & 2 NC CONTACTS
⑤ CABINET RECEPTACLE AND BOX	COMMERCIAL GRADE GFCI 20A/120V, MOUNTED IN A WEATHERPROOF CAST ALUMINUM SINGLE GANG BOX WITH WEATHERPROOF COVER
⑥ CABINET LIGHT	5 WATT LED STRIP LIGHT, 60K HOUR RATING, 65K COLOR TEMPERATURE, DOOR SWITCH CONTROLLED, FASTENED TO TOP OF CABINET
⑦ CONTACTOR	100 AMPERE, 2P, 120V COIL, MECHANICALLY HELD
⑧ BRANCH LINE CIRCUIT BREAKERS	(6) 20A, 2P, 240V RATING, 22KAIC
⑨ POWER DISTRIBUTION BLOCK	600 VOLT, INSULATED, SIZE AS REQ'D, 22KAIC
⑩ SERVICE CABLES	3-600V (XLP-TYPE USE) NO. #2
⑪ LAMPHOLDER WIRE	2-600V XLP NO. 12
⑫ CONTROL WIRE	2-600V XLP NO. 12
⑬ SURGE ARRESTOR	10 K AMPERE RATING
⑭ PHOTOELECTRIC CONTROL WIRE	3-600V XLP NO. 12
⑮ DOOR SWITCH	20A/120V, DOOR MOUNTED SNAP ACTION TYPE PLUNGER SWITCH
⑯ HAND-AUTO-OFF CONTROL SWITCH	20A, 3 POS. MTD IN CAST ALUM. ENCLOSURE
⑰ PHOTOCCELL	120V, MTD. ON CABINET, DELAY TYPE, SPST-NC
⑱ TERMINAL BLOCK	3 TERMINAL, SCREW TYPE, MAX. #10 WIRE SIZE
⑲ CIRCUIT BREAKER DIST. BLOCKS	30A, 600V, 22 KAIC - WIRE RANGE: LINE SIDE LUG (1) #2/0-#14 AWG. LOAD SIDE LUGS (2) #4-#14 AWG

**NOTES:**

- ALL ITEMS LISTED IN LIGHTING CONTROLLER COMPONENT SCHEDULE SHALL BE CONSIDERED INCIDENTAL TO THE PRICE BID FOR "LIGHTING CONTROLLER, BASE MOUNTED, 240 VOLT, 100 AMP" INCLUDING CABINET AND FOUNDATION.
- THE LIGHTING CONTROLLER TOGETHER WITH ALL OF ITS COMPONENTS SHALL BE UL LISTED AS AN "ENCLOSED INDUSTRIAL CONTROL PANEL" UNDER UL508A.
- CONNECTION OF SURGE ARRESTOR TO LINE SIDE OF MAIN CIRCUIT BREAKER SHALL NOT BE "DOUBLE LUGGED."
- THE MAIN CIRCUIT BREAKER SHALL BE LABELED "SERVICE DISCONNECT".
- ALL SWITCHES AND CONTROLS SHALL BE IDENTIFIED USING TWO COLOR ENGRAVED NAMEPLATES.
- THE PANEL MANUFACTURER SHALL LABEL THE CABINET WITH THE APPROPRIATE ARC FLASH WARNING AND PERSONNEL PROTECTION EQUIPMENT REQUIRED FOR SERVICING.
- ALL EXPOSED BUS BARS SHALL BE INSULATED.
- ALL WIRING SHALL BE COPPER.

**LIGHTING CONTROLLER COMPONENT SCHEDULE**

LIGHTING CONTROLLER CIRCUIT LOADS				
CIRCUIT ID	109W ROADWAY LUMINAIRE		TOTAL CIRCUIT LOAD	
	QTY.	LOAD/FIXT. (WATTS)	(WATTS)	AMPS (VOLTS)
A	9	175 W	1575	6.6 A (240V)
B	10	175 W	1750	7.3 A (240V)
C	11	175 W	1925 W	8.0 A (240V)
D	10	175 W	1750 W	7.3 A (240V)
TOTAL	40	N/A	7000 W	29.2 A (240V)

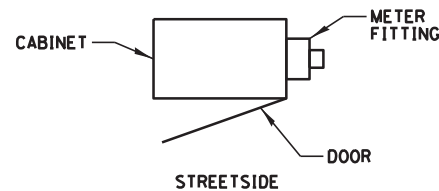

**CABINET METER FITTING & DOOR ORIENTATION**

N.T.S.

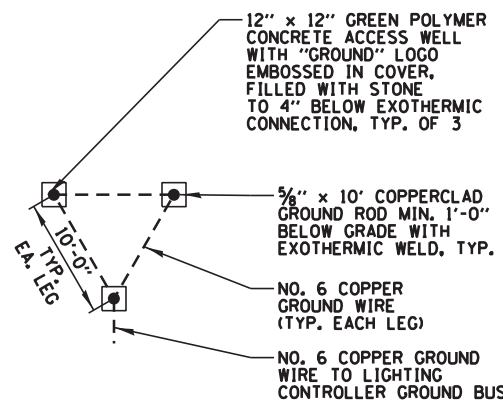

**GROUND FIELD DETAIL (TYP.)**

N.T.S.

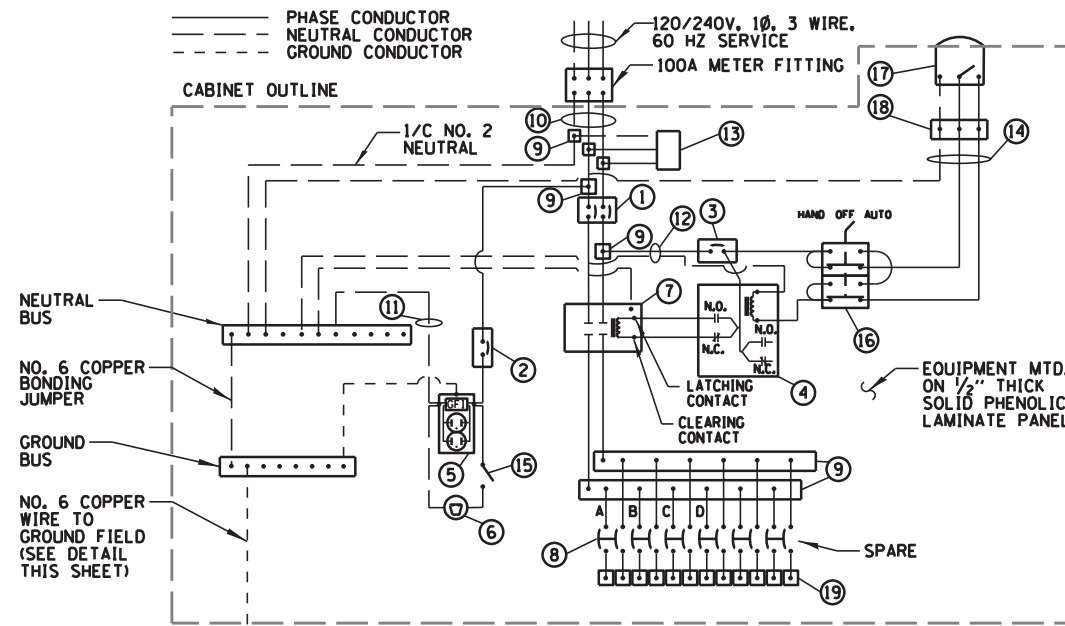

**NOTES:**

- ALL GROUND CONDUCTORS SHALL BE GREEN AND NEUTRAL CONDUCTORS SHALL BE WHITE. PHASE CONDUCTORS SHALL BE COLOR CODED IN ACCORDANCE WITH SECTION 1066.02 OF THE STANDARD SPECIFICATIONS. CONTRACTOR SHALL ONLY USE SOLID COLOR CODED INSULATIONS. COLOR STRIPPING OF PHASE CONDUCTORS SHALL NOT BE ALLOWED.
- IN ADDITION TO THE TERMINATIONS SHOWN, THE NEUTRAL AND GROUND BUS BARS SHALL EACH ACCOMMODATE A MINIMUM OF 8 ADDITIONAL TERMINATIONS (#2-#14).

**LIGHTING CONTROLLER WIRING DETAIL**

N.T.S.

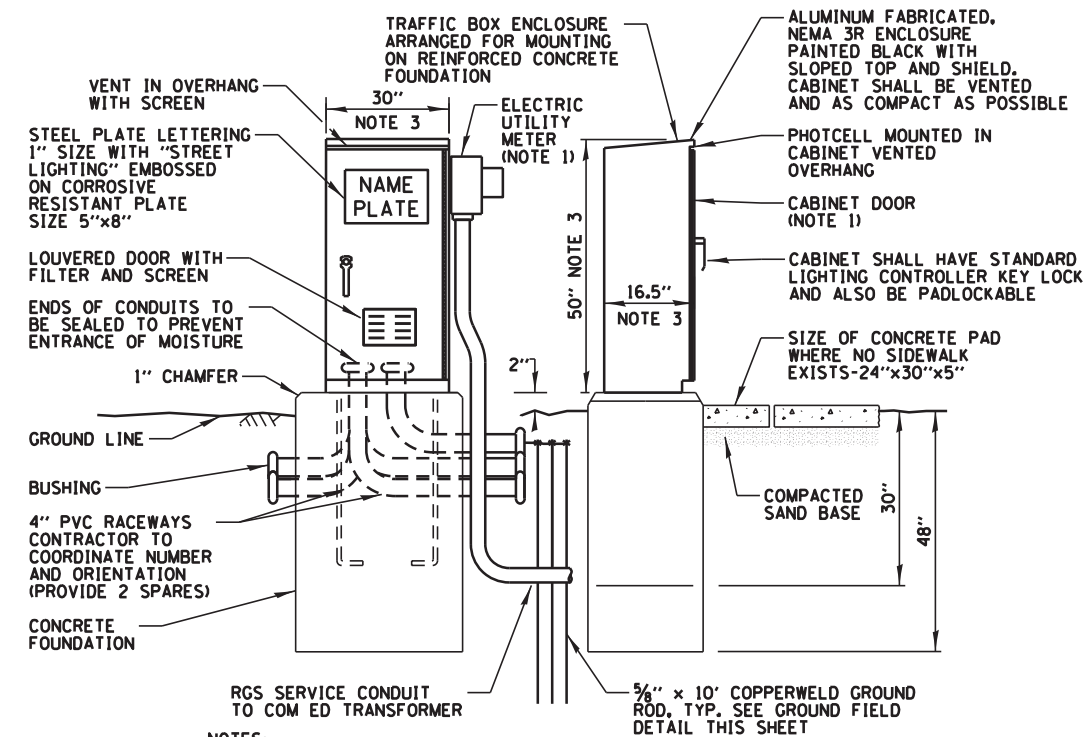

**NOTES:**

- SEE CABINET METER FITTING AND DOOR ORIENTATION DETAIL FOR METER AND DOOR ORIENTATION.
- ALL ITEMS SHOWN ABOVE (INCLUDING FOUNDATION & GROUND FIELD) SHALL BE INCLUDED IN THE PRICE BID FOR "LIGHTING CONTROLLER, BASE MOUNTED, 240VOLT, 100AMP", EXCEPT FOR THE SERVICE CONDUIT WHICH WILL BE PAID FOR SEPARATELY.
- CABINET DIMENSIONS SHOWN ARE APPROXIMATE, CABINET SHALL BE AS COMPACT AS POSSIBLE, CONTRACTOR TO COORDINATE.

**LIGHTING CONTROLLER CABINET AND FOUNDATION**

N.T.S.



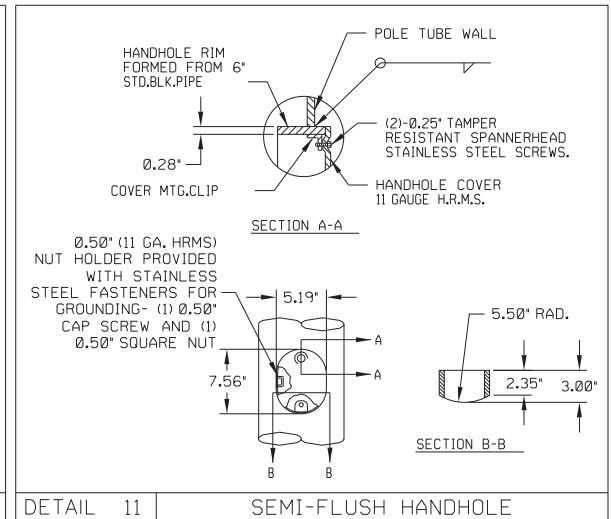
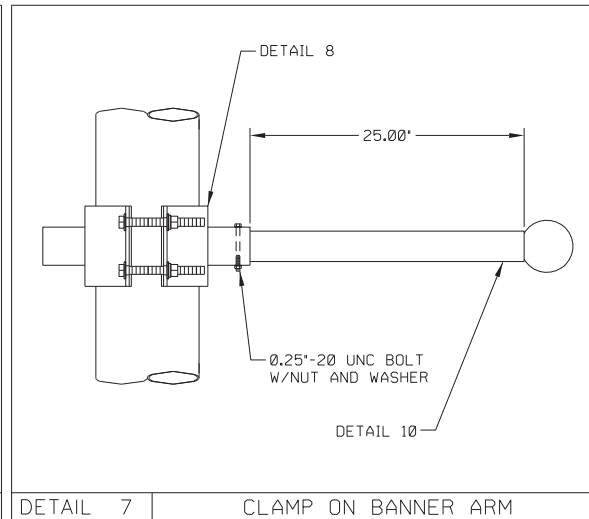
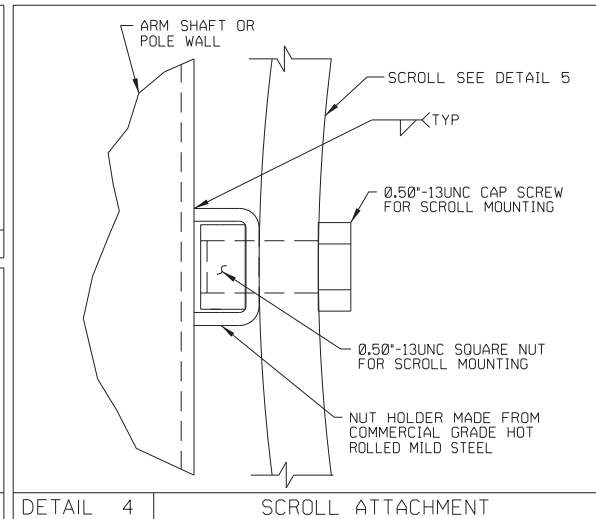
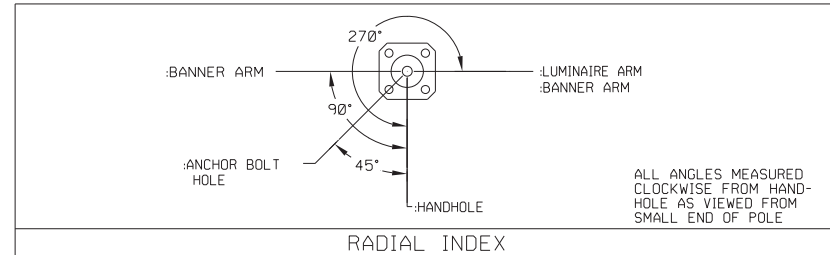
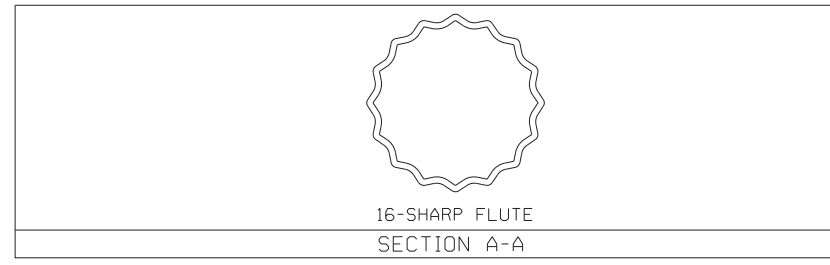
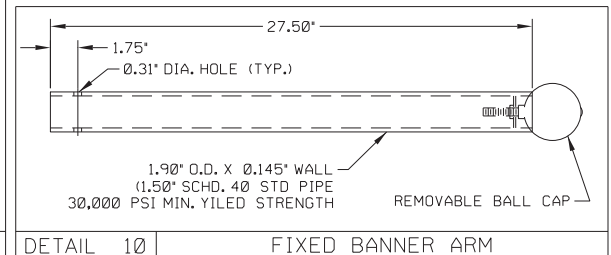
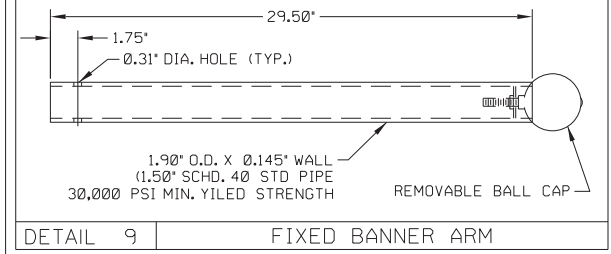
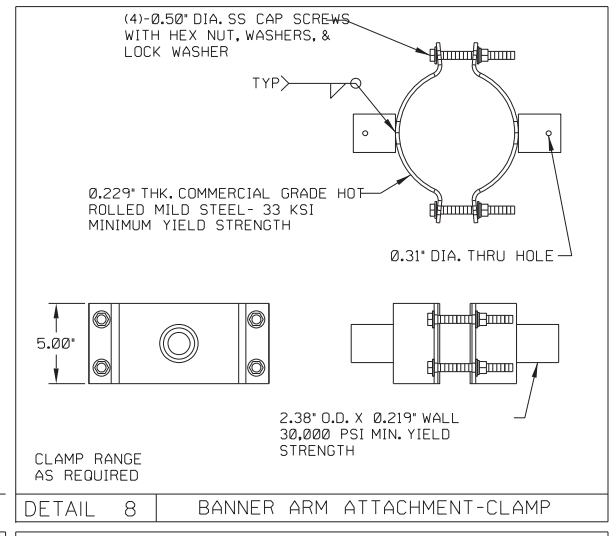
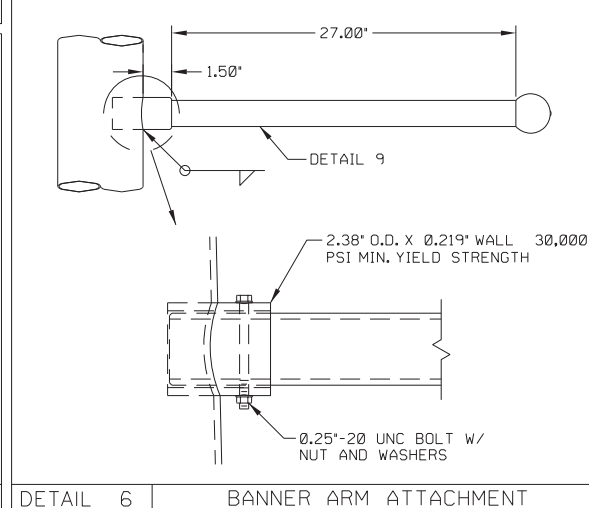
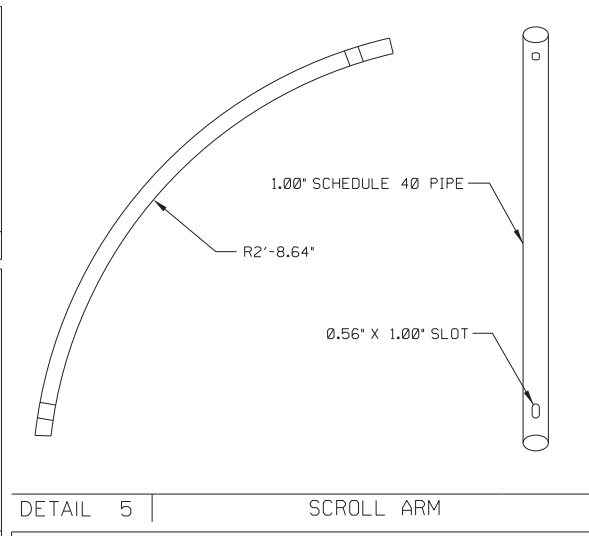
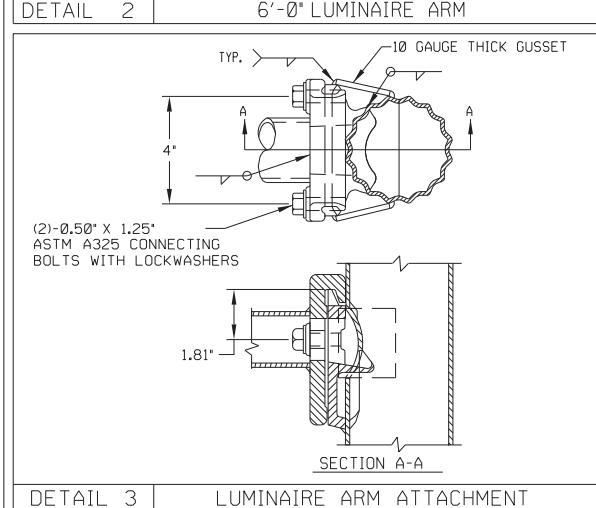
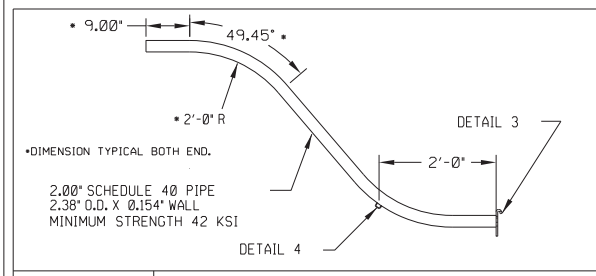
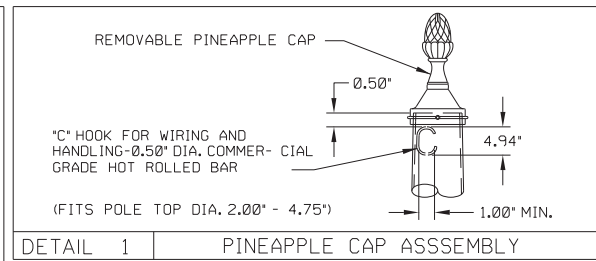
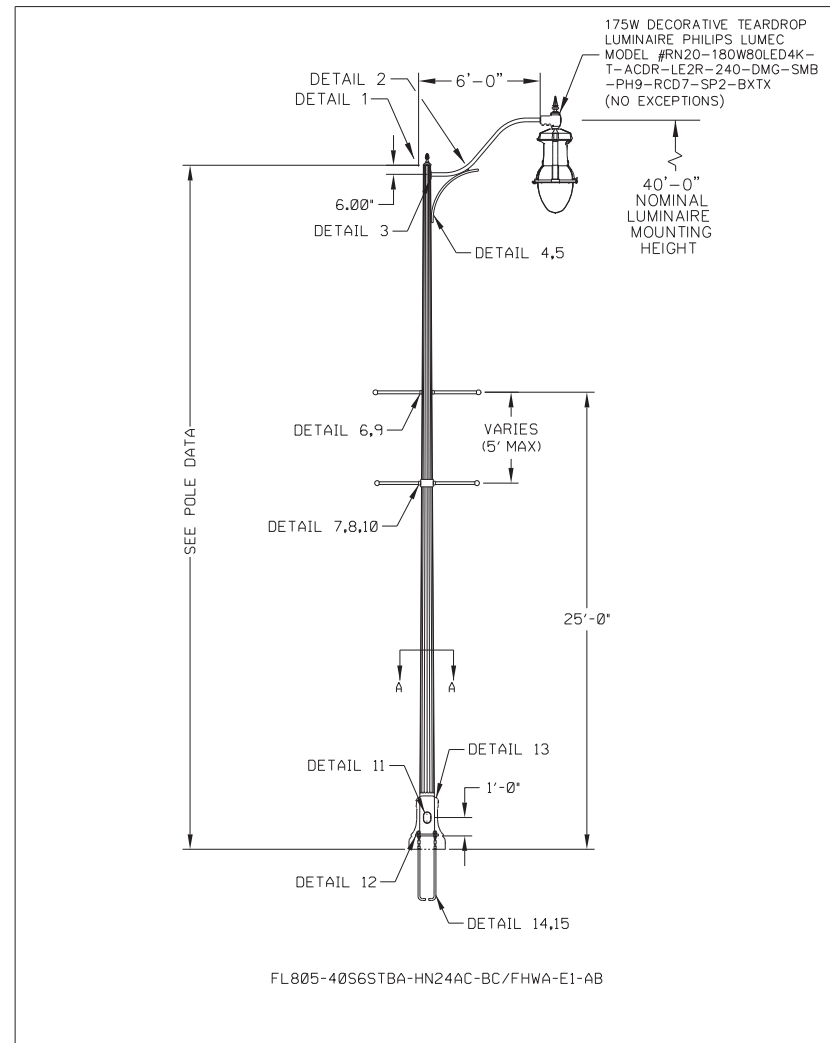

PAID FOR UNDER "ORNAMENTAL LIGHT UNIT COMPLETE" (SEE SPECIAL PROVISION).

FILE NAME =	USER NAME = adericco	DESIGNED - AJD	REVISED -
N:\WBK\150077.2\Mech\LDT_150077.2-02.sht		DRAWN - JRB	REVISED -
Default		CHECKED - AJD	REVISED -
	PLOT DATE = 10/16/2017	DATE - 10/16/2017	REVISED -

STATE OF ILLINOIS  
DEPARTMENT OF TRANSPORTATION

AURORA TRANSIT CENTER IMPROVEMENTS  
ROADWAY LIGHTING DETAILS (2 OF 8)

SCALE: N.T.S. SHEET OF 254 SHEETS STA. TO STA.

F.A.U. RTE.	SECTION	COUNTY	TOTAL SHEETS	SHEET NO.
2503	16-00313-00-MS	KANE	254	149
CONTRACT NO. 61E18				
ILLINOIS FED. AID PROJECT				

POLE AND LUMINAIRE ARM DATA

ITEM	QTY.	POLE TUBE				POLE BASE				ANCHOR BOLT				LUMINAIRE ARM TUBE	
		BASE DIA. (IN)	TOP DIA. (IN)	LENGTH (FT)	GAUGE OR THK. (IN)	SQUARE "S" (IN)	BOLT CIRCLE "Y" (IN)	THK. "M" (IN)	HOLE / SLOT "Z" (IN)	DIA. "K" (IN)	LENGTH "J" (IN)	HOOK "H" (IN)	THREAD LENGTH "U" (IN)	PIPE OUTSIDE DIA. (IN)	WALL THICKNESS (IN)
FL805-40S6STBA-HN24AC-BC/FHWA-E1-AB	40	8.50	3.25	37.50	7	13.00	13.00	1.25	1.38 x 1.94	1.25	42.00	6.00	6.00	2.38	0.154

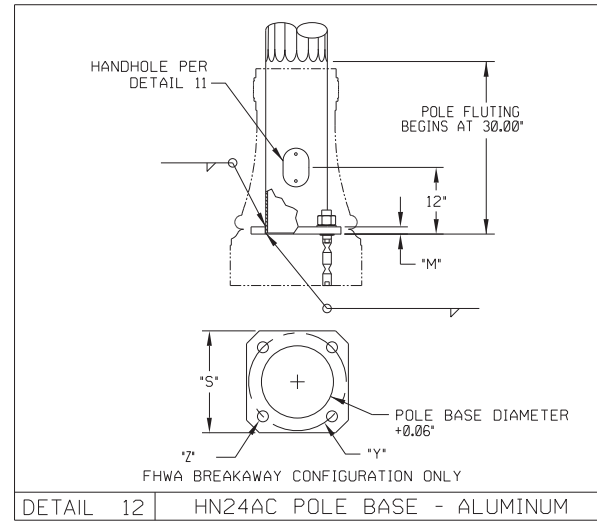

DETAIL 12 HN24AC POLE BASE - ALUMINUM

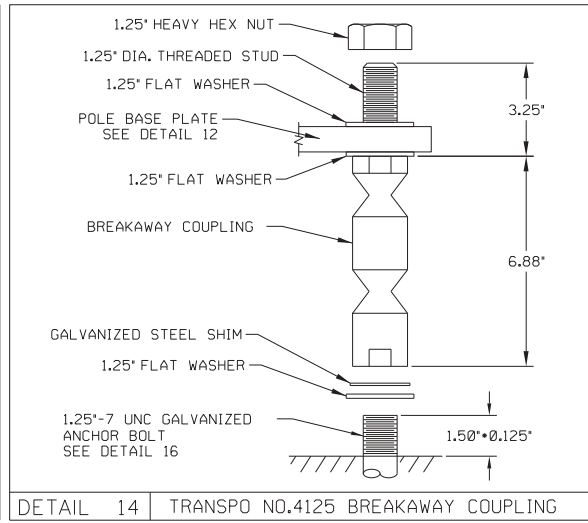

DETAIL 14 TRANSPONER NO.4125 BREAKAWAY COUPLING

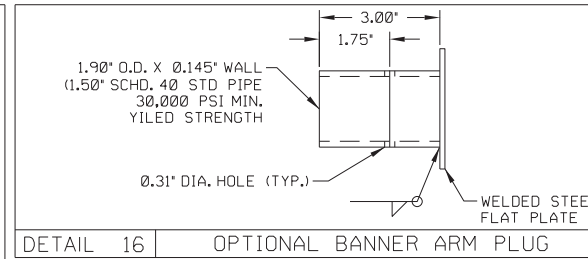

DETAIL 16 OPTIONAL BANNER ARM PLUG

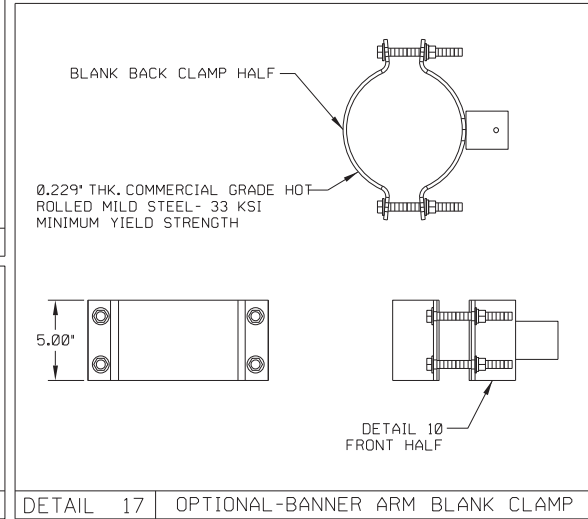

DETAIL 17 OPTIONAL-BANNER ARM BLANK CLAMP

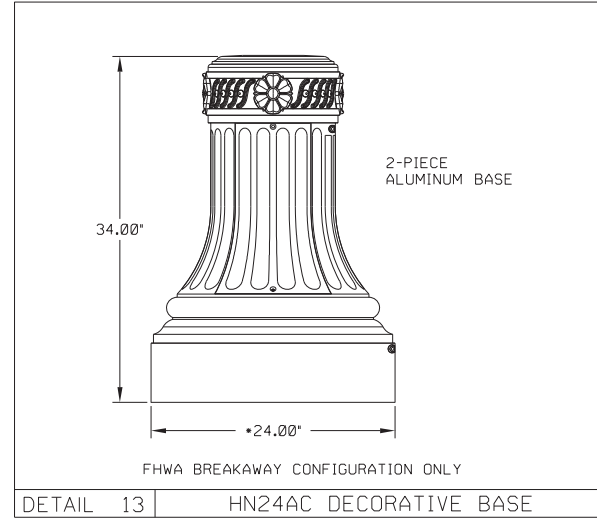

DETAIL 13 HN24AC DECORATIVE BASE

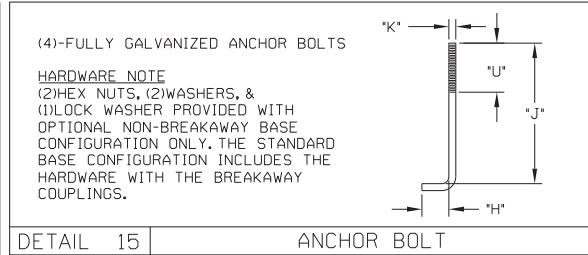

DETAIL 15 ANCHOR BOLT

NOTES:

- POLE SHAFTS SHALL CONFORM TO ASTM A595 GRA WITH 55,000 P.S.I. MINIMUM YIELD STRENGTH. LINEAR TAPER OF 0.14"/FT.
- BASE PLATE CONFORMS TO ASTM: A709 GR.50.
- ANCHOR BOLTS-ALL STRUCTURES:ASTM F1554 GR.55 55,000 P.S.I. MINIMUM YIELD STRENGTH.
- CAST POLE TOP CAP-SECURED IN PLACE WITH 3 STAINLESS STEEL SET SCREWS.
- ALL NON-STAINLESS THREADED FASTENERS TO BE HOT DIP GALVANIZED TO ASTM DESIGNATION: A153 (AASHTO M232).
- LUMINAIRE ARM SHAFT CONFORMS TO 2" SCHED. 40 PIPE WITH 42,000 P.S.I. MINIMUM YIELD STRENGTH.
- LUMINAIRE ATTACHMENT CONFORMS TO ASTM A27 GR. 65-35.
- SHAFT GAUGE OR THICKNESS ARE AS FOLLOWS:7 GA.= 0.1793".

LOADING AND ALLOWABLE STRESS CRITERIA: 1994 AASHTO "STANDARD SPECIFICATIONS FOR STRUCTURAL SUPPORTS FOR SIGNS, LUMINAIRES AND TRAFFIC SIGNALS".

STATE OF ILLINOIS

GENERAL NOTES

FINISH DATA

SYSTEM: V-PRO54 (VP54)  
 BASE COAT: HOT DIP GALVANIZE TO ASTM A123  
 PRIME COAT: HIGH BUILD EPOXY POWDER  
 FINISH COAT: SUPER DURABLE POWDER  
 COLOR: AURORA BLACK  
 VALMONT SPEC: F-573A (5 YEAR WARRANTY SPEC.)

- NOTES:
- ANTI SEIZE FOR HANDHOLE COVER SCREWS PROVIDED BY CONTRACTOR DURING INSTALLATION.
  - ALL ORIENTATIONS MUST BE VERIFIED PRIOR TO RELEASE FOR PRODUCTION.
  - OPTIONAL BANNER ARM PLUGS WITH WELDED FLAT PLATE CAN BE PROVIDED (DETAIL 15).
  - OPTIONAL BLANK BACK HALF CLAMP CAN BE PROVIDED IF A SINGLE BANNER ARM IS USED (DETAIL 16).
  - SYSTEM INCLUSIVE OF POLE, COUPLINGS, AND VALMONT DECORATIVE CLAM SHELL BASE SHALL CARRY FHWA BREAKAWAY RATING AND BE LISTED AS SUCH.
  - PAID FOR UNDER "ORNAMENTAL LIGHT UNIT, COMPLETE" (SEE SPECIAL PROVISIONS). THIS IS A PROPRIETARY ITEM.

PAID FOR UNDER "ORNAMENTAL LIGHT UNIT COMPLETE" (SEE SPECIAL PROVISION).

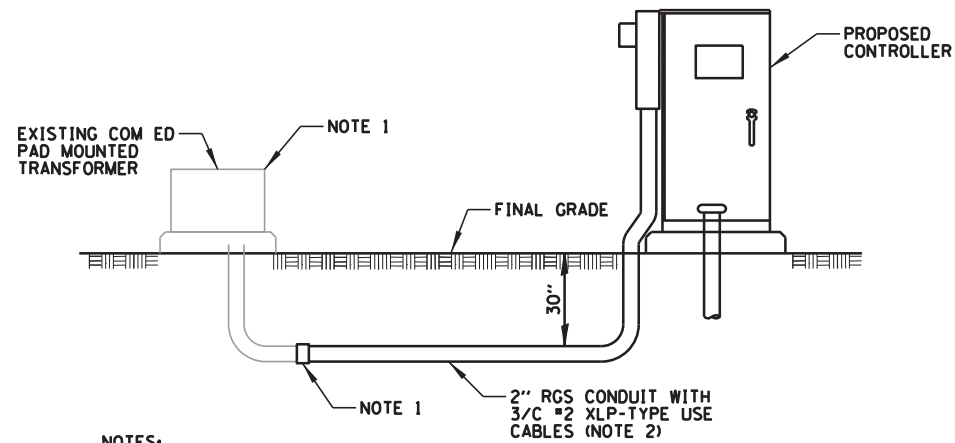

**NOTES:**

1. CONNECT SERVICE CONDUIT TO EXISTING 2" CONDUIT STUB OUT OF TRANSFORMER. PROVIDE ADEQUATE SLACK CABLE COILED UP FOR COM ED TO CONNECT. CONTRACTOR TO SCHEDULE & COORDINATE ALL WORK WITH COM ED.
2. THIS WORK PAID FOR UNDER "ELECTRIC SERVICE INSTALLATION". THE HORIZONTAL SERVICE CONDUIT & WIRE FROM THE TRANSFORMER TO THE CONTROLLER PAID FOR SEPARATELY.

**ELECTRIC SERVICE UNDERGROUND CONNECTION TO TRANSFORMER**  
N.T.S.

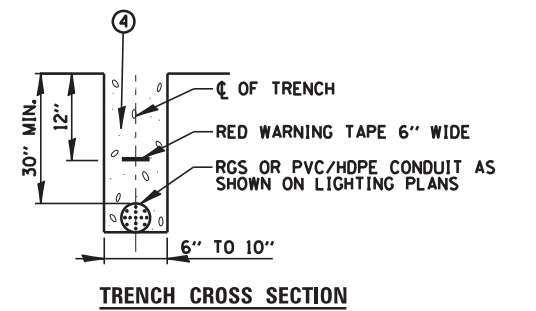
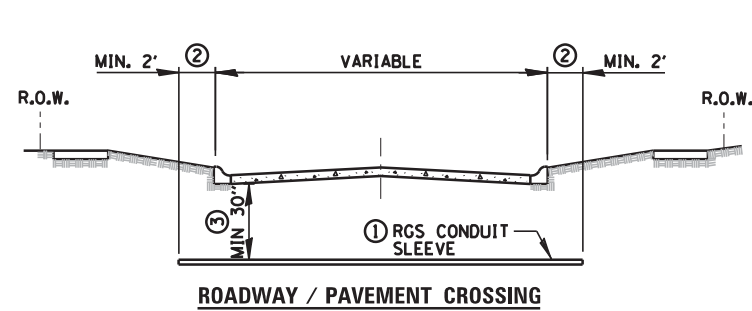

- ① SLEEVE SHALL BE HEAVY WALL RIGID GALVANIZED STEEL (RGS) CONDUIT.
- ② SLEEVE SHALL EXTEND A MINIMUM OF 2 FT. BEYOND BACK OF CURB.
- ③ SLEEVE SHALL BE A MINIMUM OF 30" BELOW ROADWAY OR CURB BOTTOM.
- ④ BACKFILL MATERIAL FOR TRENCHES IN THE SUBGRADE OF THE PROPOSED IMPROVEMENT, AND FOR TRENCHES OUTSIDE OF THE SUBGRADE WHERE THE INNER EDGE OF THE TRENCH IS WITHIN 2 FT OF THE EDGE OF THE PAVEMENT, CURB, GUTTER, CURB AND GUTTER, STABILIZED SHOULDER, OR SIDEWALK SHALL BE TRENCH BACKFILL.

**ELECTRIC CONDUIT INSTALLATION**  
N.T.S.

—— PHASE CONDUCTOR  
- - - - GROUND CONDUCTOR

TO 240V ROADWAY LUMINAIRE

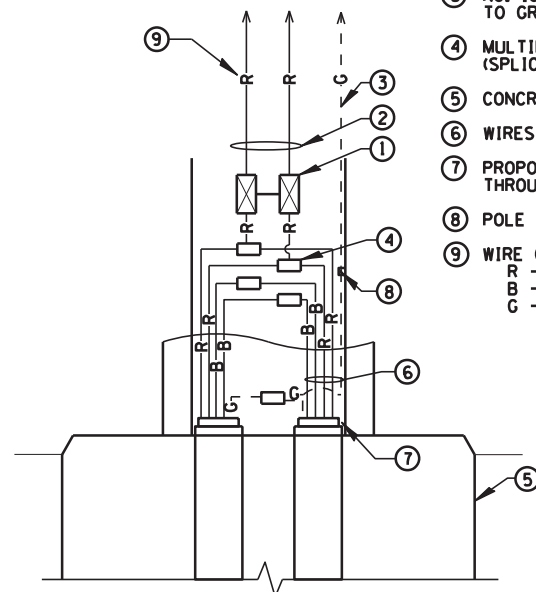

**HANDHOLE WIRING DIAGRAM**  
N.T.S.

- ① 3A TIME-DELAY TYPE FUSE INSIDE A 2-POLE BREAKAWAY WATERPROOF FUSE HOLDER & INSULATING BOOTS
- ② NO. 10 POLE WIRES TO LUMINAIRE COLOR TO MATCH BRANCH WIRING
- ③ NO. 10 GROUND WIRE CONNECTED TO GROUND LUG IN LUMINAIRE
- ④ MULTIPLE COMPRESSION FITTINGS (SPICE), TYP.
- ⑤ CONCRETE FOUNDATION
- ⑥ WIRES AS SHOWN ON PLANS
- ⑦ PROPOSED LIGHTING CONDUIT PULLED THROUGH PVC RACEWAY
- ⑧ POLE GROUND LUG
- ⑨ WIRE COLOR  
R - RED  
B - BLACK  
G - GREEN

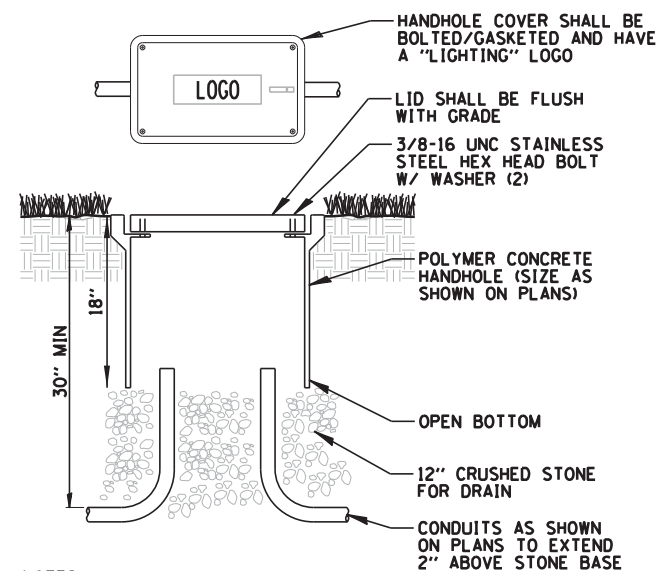

**NOTES:**

1. NO SPLICES ALLOWED IN HANDHOLE.
2. POLYMER CONCRETE HANDHOLE AND LID SHALL BE GRAY.
3. BOX & LID SHALL MEET/EXCEED ANSI TIER 15 LOADING REQUIREMENTS, AND BE TESTED IN ACCORDANCE WITH THE LATEST EDITION OF THE ANSI/SCTE 77 "SPECIFICATION FOR UNDERGROUND ENCLOSURE INTEGRITY", AND THE PROVISIONS OF PARAGRAPHS 5.2.3 AND 5.2.4 OF WESTERN UNDERGROUND COMMITTEE GUIDE 3.6.
4. PAID FOR UNDER "HANDHOLE, COMPOSITE CONCRETE" (SEE SPECIAL PROVISION).

**COMPOSITE CONCRETE HANDHOLE**  
N.T.S.

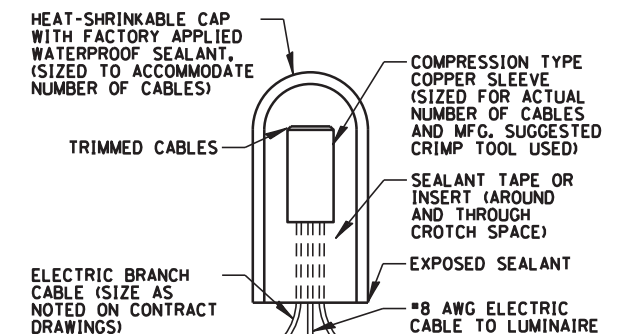

**SPLICING ELECTRIC CABLE**  
N.T.S.

FILE NAME =	USER NAME = adericco	DESIGNED - AJD	REVISED -
N:\WBK\150077.2\Mech\LD1_150077.2-04.sht		DRAWN - JRB	REVISED -
Default	PLOT SCALE = 2"	CHECKED - AJD	REVISED -
	PLOT DATE = 10/16/2017	DATE - 10/16/2017	REVISED -

STATE OF ILLINOIS  
DEPARTMENT OF TRANSPORTATION

AURORA TRANSIT CENTER IMPROVEMENTS  
ROADWAY LIGHTING DETAILS (4 OF 8)

SCALE: N.T.S. SHEET OF 254 SHEETS STA. TO STA.

F.A.U. RTE.	SECTION	COUNTY	TOTAL SHEETS	SHEET NO.
2503	16-00313-00-MS	KANE	254	151
CONTRACT NO. 61E18				
ILLINOIS FED. AID PROJECT				

**LIGHT POLE FOUNDATION DEPTH TABLE**  
40 FT. (12.192 m) TO 47.5 FT. (14.478 m) MOUNTING HEIGHT

SOIL CONDITIONS	DESIGN DEPTH "D" OF FOUNDATION	
	SINGLE ARM POLE	TWIN ARM POLE
SOFT CLAY Ou = 0.375 TON/SO. FT.	13'-0" (3.96 m)	15'-0" (4.57 m)
MEDIUM CLAY Ou = 0.75 TON/SO. FT.	9'-6" (2.93 m)	10'-9" (3.23 m)
STIFF CLAY Ou = 1.50 TON/SO. FT.	7'-0" (2.13 m)	8'-0" (2.44 m)
LOOSE SAND φ = 34°	9'-0" (2.74 m)	10'-0" (3.05 m)
MEDIUM SAND φ = 37.5°	8'-3" (2.52 m)	9'-0" (2.74 m)
DENSE SAND φ = 40°	7'-9" (2.36 m)	9'-0" (2.74 m)

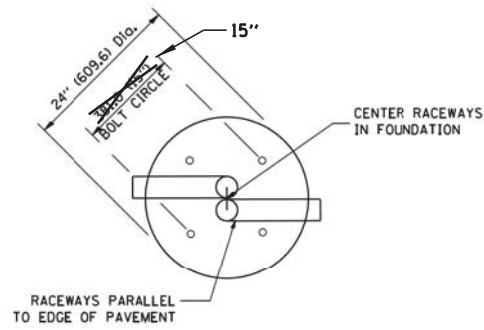

**TOP VIEW**

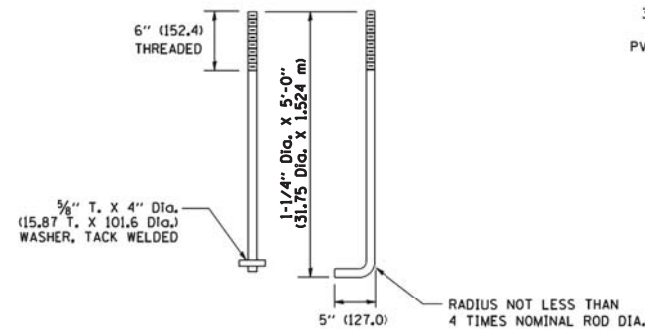

**ANCHOR ROD DETAIL**

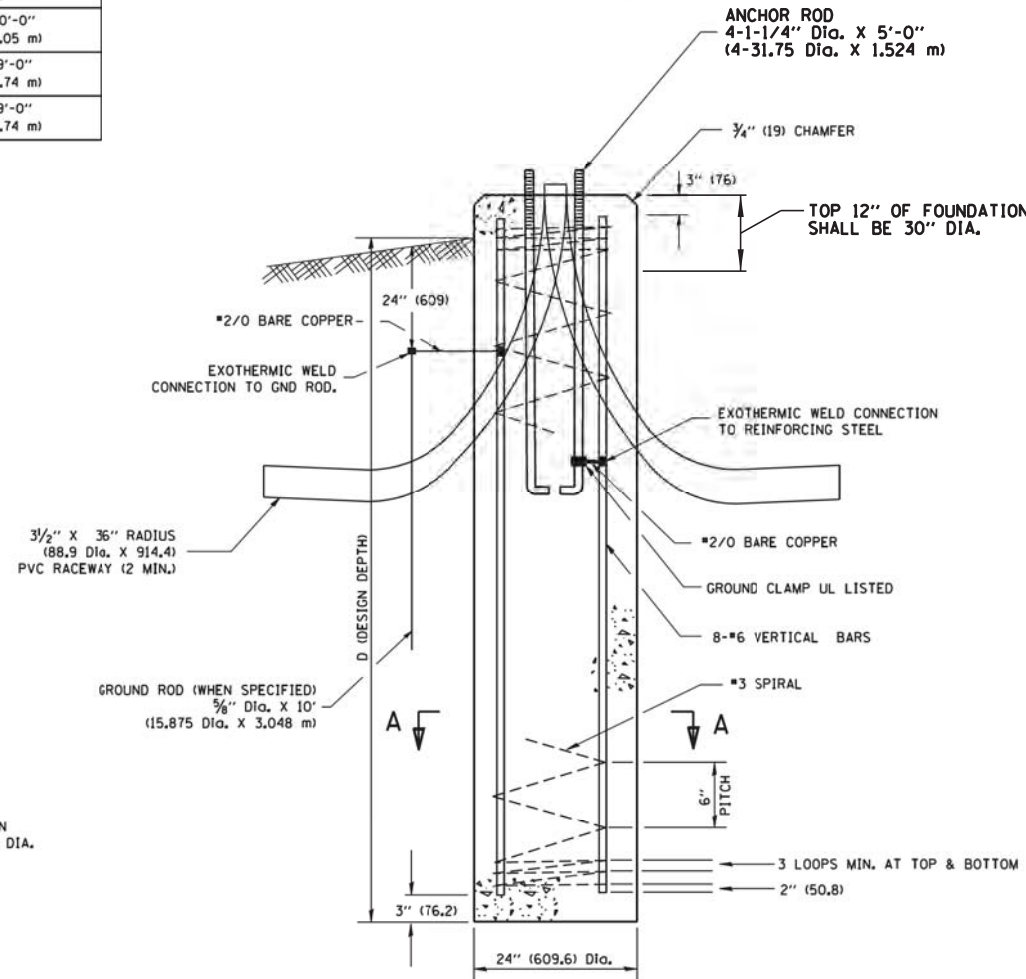

**FOUNDATION DETAIL**

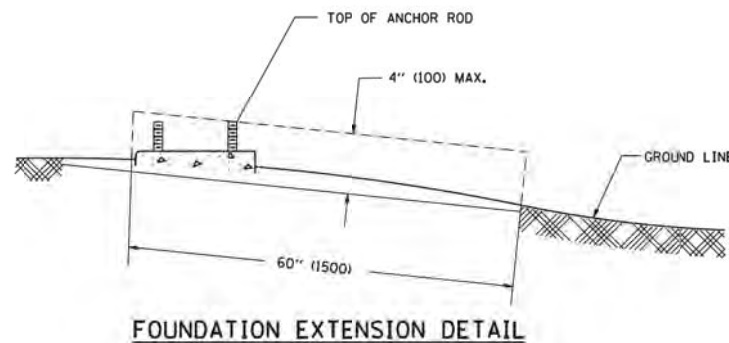

**FOUNDATION EXTENSION DETAIL**

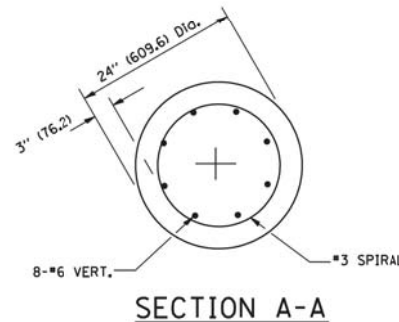

**SECTION A-A**

**NOTES**

- ALL DIMENSIONS ARE IN INCHES (MILLIMETERS) UNLESS OTHERWISE SHOWN.
- THE ANCHOR RODS AND RACEWAYS SHALL BE PROPERLY SECURED IN PLACE BEFORE THE CONCRETE IS PLACED.
- THE FOUNDATION SHALL NOT PROTRUDE MORE THAN 100MM (4 IN.) ABOVE THE FINISHED GRADE WITHIN A 60 IN. (1.5 m) CHORD ACROSS THE FOUNDATION, WITH ANCHOR RODS INCLUDED. IN ACCORDANCE WITH AASHTO GUIDELINES, IF THE FOUNDATION HEIGHT, INCLUDING ANCHOR RODS, EXTENDS BEYOND THESE SPECIFIED LIMITS, THE FOUNDATION SHALL BE REPLACED AT THE CONTRACTOR'S EXPENSE. SEE FOUNDATION EXTENSION DETAIL.
- THE HOLE FOR THE FOUNDATION SHALL BE MADE BY DRILLING WITH AN AUGER, OF THE SAME DIAMETER AS THE FOUNDATION. IF SOIL CONDITIONS REQUIRE THE USE OF A LINER TO FORM THE HOLE, THE LINER SHALL BE WITHDRAWN AS THE CONCRETE IS DEPOSITED.
- THE TOP OF THE FOUNDATION SHALL BE CONSTRUCTED LEVEL. A LINER OR FORM SHALL BE USED TO PRODUCE A UNIFORM SMOOTH SIDE TO THE TOP OF THE FOUNDATION. FOUNDATION TOP SHALL BE CHAMFERED 3/4-IN. (20 mm).
- THE CONCRETE SHALL BE CLASS S1. CONCRETE SHALL CURE ACCORDING TO ARTICLE 1020.13 BEFORE LIGHT POLES ARE INSTALLED.
- THE ANCHOR ROD SHALL BE A HOOK ROD TYPE. COLD BENDING OF THE ANCHOR ROD WILL NOT BE ALLOWED. THE RADIUS OF THE HOOK BEND SHALL NOT BE LESS THAN 4 TIMES THE NOMINAL DIAMETER OF THE ANCHOR ROD. A TACK WELDED ANCHOR ROD MAY BE SUBSTITUTED WITH THE APPROVAL OF THE ENGINEER.
- THE ANCHOR RODS SHALL BE ACCORDING TO ASTM F1554 GRADE 725 (GRADE 105). NUTS SHALL BE HEXAGON NUTS ACCORDING TO ASTM A 194 2H OR ASTM A 563 DH, AND WASHERS SHALL BE ACCORDING TO ASTM F 436.
- ANCHOR RODS, NUTS AND WASHERS SHALL BE COMPLETELY GALVANIZED BY EITHER THE HOT-DIPPED PROCESS CONFORMING WITH AASHTO M 232, THE MECHANICAL PLATING METHOD CONFORMING TO AASHTO M 298, CLASS 50 WITH A MAXIMUM COATING THICKNESS OF 150 UM(6 MILS) OR THE ELECTROLYTIC PROCESS ACCORDING TO ASTM F 1136.
- THE ANCHOR RODS SHALL BE THREADED A MINIMUM OF 6 INCHES (150 mm) WITH A MINIMUM OF 3 INCHES (75 mm) OF THREADED ANCHOR ROD EMBEDDED IN THE FOUNDATION.
- ANCHOR RODS SHALL PROJECT 2 3/4" (69.9 mm) ABOVE THE TOP OF THE FOUNDATION. IF BREAKAWAY COUPLINGS ARE SPECIFIED, THE CONTRACTOR SHALL CAREFULLY COORDINATE THE ANCHOR ROD PROJECTION WITH THE INSTALLATION REQUIREMENTS OF THE BREAKAWAY COUPLINGS.
- THE CONTRACTOR SHALL USE A #3 SPIRAL AT 6" (152.4 mm) PITCH OR MAY SUBSTITUTE #3 TIES AT 12" (304.8 mm) O.C. WITH THE APPROVAL OF THE ENGINEER.
- THE CABLE TRENCHES AND FOUNDATION SHALL BE BACK FILLED AND COMPACTED AS SPECIFIED BEFORE THE LIGHT POLE IS ERECTED.
- THE RACEWAYS SHALL PROJECT 1" (25.4 mm) ABOVE THE TOP OF THE FOUNDATION.

PAID FOR UNDER "LIGHT POLE FOUNDATION, 24" DIAMETER, SPECIAL" (SEE SPECIAL PROVISION).

**IDOT STANDARD BE-301**

FOUNDATION DESIGN TABLE

TYPE OF SOIL	DESIGN DEPTH OF FOUNDATION		REINFORCEMENT IN FOUNDATION			
	SINGLE ARM D	TWIN ARM D	SINGLE ARM		TWIN ARM	
			VERT BARS	SPIRAL	VERT BARS	SPIRAL
SOFT CLAY	13'-0" (3.962 m)	15'-0" (4.572 m)	8-#6X12'-6" (3.810 m)	#3X122' (37.186 m)	8-#6X14'-3" (4.343 m)	#3X141' (42.977 m)
MEDIUM CLAY	9'-6" (2.896 m)	10'-9" (3.277 m)	8-#6X9'-0" (2.743 m)	#3X90' (27.432 m)	8-#6X10'-0" (3.048 m)	#3X100' (30.480 m)
STIFF CLAY	7'-0" (2.134 m)	8'-0" (2.438 m)	8-#6X6'-6" (1.981 m)	#3X66' (20.112 m)	8-#6X7'-6" (2.286 m)	#3X76' (23.165 m)
LOOSE SAND	9'-0" (2.743 m)	10'-0" (3.048 m)	8-#6X8'-6" (2.591 m)	#3X85' (25.908 m)	8-#6X9'-6" (2.896 m)	#3X94' (28.651 m)
MEDIUM SAND	8'-3" (2.515 m)	9'-0" (2.743 m)	8-#6X8'-0" (2.438 m)	#3X78' (23.774 m)	8-#6X8'-6" (2.591 m)	#3X85' (25.908 m)
DENSE SAND	7'-9" (2.362 m)	9'-0" (2.743 m)	8-#6X7'-6" (2.286 m)	#3X73' (22.250 m)	8-#6X8'-6" (2.591 m)	#3X85' (25.908 m)
ROCK OR SOLIDIFIED SLAG	5'-0" (1.524 m)	5'-0" (1.524 m)	NONE	NONE	NONE	NONE

CONTRACTOR SHALL USE A STANDARD CONCRETE FOUNDATION WHEREVER POSSIBLE. IF UTILITY CONFLICTS PROHIBIT THE USE OF A STANDARD CONCRETE FOUNDATION, THE CONTRACTOR SHALL CONSULT WITH OWNER'S REPRESENTATIVE PRIOR TO THE USE OF AN OFFSET FOUNDATION.

NOTES

- ALL DIMENSIONS ARE IN INCHES (MILLIMETERS) UNLESS OTHERWISE SHOWN.
- THE ENGINEER SHALL DETERMINE THE CLASS OF SOIL DURING EXCAVATION AND SELECT THE DESIGN DEPTH OF FOUNDATION FROM THE DESIGN TABLE.
- EXCAVATION OF THE POLE FOUNDATION SHALL BE MADE WITH AN AUGER, 24" (609.6 mm) OR 30" (762.0 mm) IN DIAMETER.
- THE ANCHOR ROD SHALL BE A HOOK ROD TYPE. COLD BENDING OF THE ANCHOR ROD WILL NOT BE ALLOWED. THE RADIUS OF THE HOOK BEND SHALL NOT BE LESS THAN 4 TIMES THE NOMINAL DIAMETER OF THE ANCHOR ROD. A TACK WELDED ANCHOR ROD MAY BE SUBSTITUTED WITH THE APPROVAL OF THE ENGINEER.
- THE ANCHOR BOLTS AND RACEWAYS SHALL BE PROPERLY SECURED IN PLACE BEFORE THE CONCRETE IS PLACED IN THE FORM.
- THE ANCHOR RODS SHALL BE ACCORDING TO ASTM F1554 GRADE 725 (GRADE 105). NUTS SHALL BE HEXAGON NUTS ACCORDING TO ASTM A 194 2H OR ASTM A 563 DH, AND WASHERS SHALL BE ACCORDING TO ASTM F 436.
- THE CONTRACTOR SHALL COORDINATE EXTENSION OF ANCHOR BOLTS ABOVE TOP OF FOUNDATION WITH THE BREAKAWAY DEVICE MANUFACTURER'S REQUIREMENTS. IF LIGHT POLE IS MOUNTED WITHOUT BREAKAWAY DEVICE, ANCHOR BOLTS SHALL PROJECT 2 3/4" (69.9 mm) ABOVE TOP OF THE FOUNDATION. THE CONTRACTOR SHALL CONFIRM ANCHOR BOLT EXTENTION WITH ENGINEER.
- RACEWAYS SHALL PROJECT 1" (25.4 mm) ABOVE THE TOP OF THE FOUNDATION.
- THE CABLE TRENCH SHALL BE BACKFILLED AND FIRMLY COMPACTED BEFORE THE LIGHT IS ERRECTED.

PAID FOR UNDER "LIGHT POLE FOUNDATION, 24" DIAMETER, OFFSET" (SEE SPECIAL PROVISION).

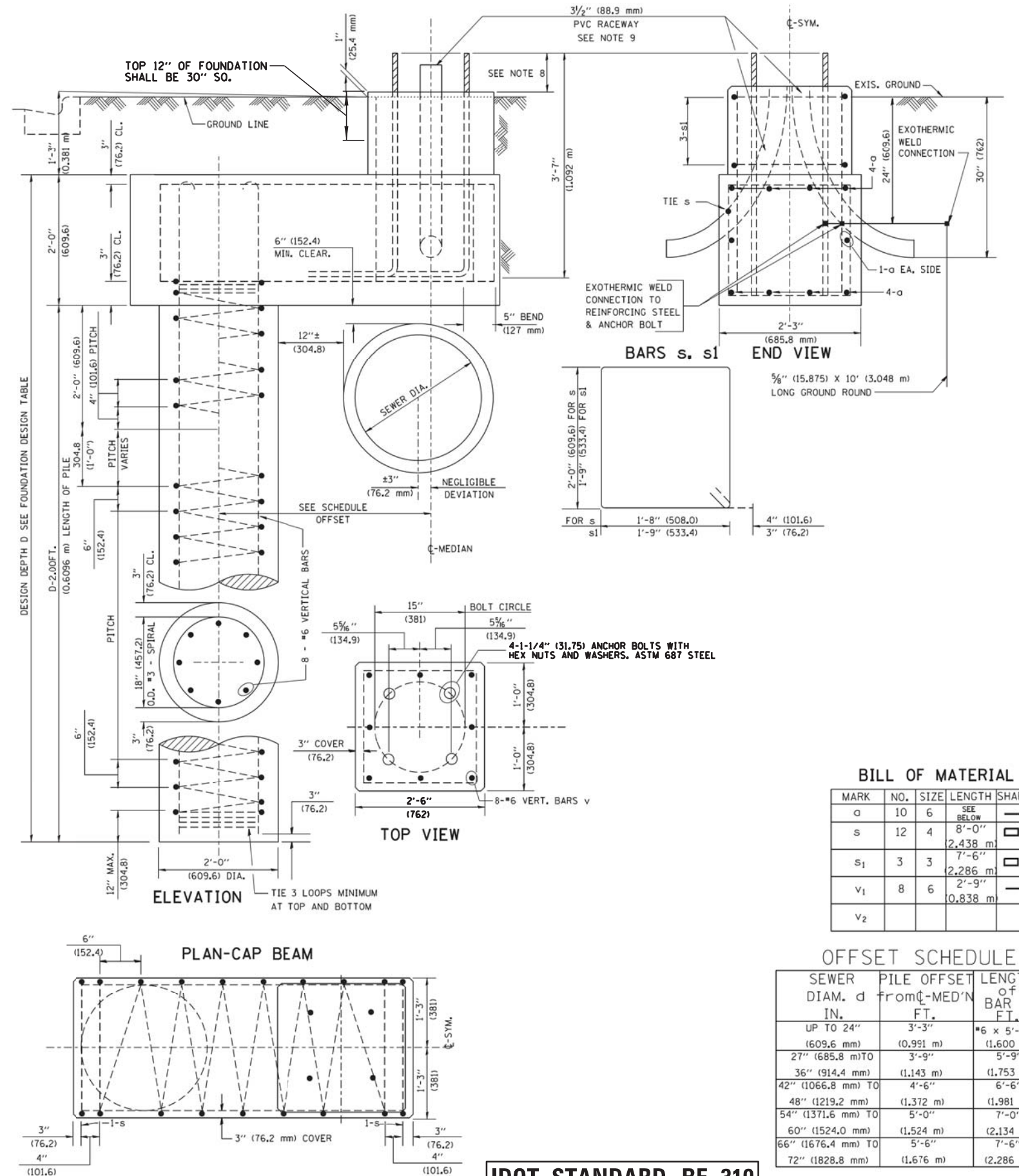

BILL OF MATERIAL

MARK	NO.	SIZE	LENGTH	SHAPE
a	10	6	SEE BELOW	—
s	12	4	8'-0" (2,438 m)	□
s <sub>1</sub>	3	3	7'-6" (2,286 m)	□
v <sub>1</sub>	8	6	2'-9" (0,838 m)	—
v <sub>2</sub>				

OFFSET SCHEDULE

SEWER DIAM. d IN.	PILE OFFSET from C-MED'N FT.	LENGTH of BAR a FT.
UP TO 24" (609.6 mm)	3'-3" (0.991 m)	#6 x 5'-3" (1,600 m)
27" (685.8 mm) TO	3'-9" (1.143 m)	5'-9" (1,753 m)
36" (914.4 mm)	4'-6" (1,372 m)	6'-6" (1,981 m)
42" (1066.8 mm) TO	5'-0" (1,524 m)	7'-0" (2,134 m)
48" (1219.2 mm)	5'-6" (1,676.4 mm)	7'-6" (2,286 m)
54" (1371.6 mm) TO	6'-0" (1,828.8 mm)	
60" (1524.0 mm)		
66" (1676.4 mm) TO		
72" (1828.8 mm)		

IDOT STANDARD BE-310

FILE NAME -	USER NAME - aderico	DESIGNED - AJD	REVISED -
N:\WBK\150077.2\Mech\LD1.150077.2-06.sht		DRAWN - JRB	REVISED -
Default		CHECKED - AJD	REVISED -
		DATE - 10/16/2017	REVISED -

STATE OF ILLINOIS  
DEPARTMENT OF TRANSPORTATION

AURORA TRANSIT CENTER IMPROVEMENTS  
ROADWAY LIGHTING DETAILS (6 OF 8)

SCALE: N.T.S. SHEET OF 254 SHEETS STA. TO STA.

F.A.U. RTE.	SECTION	COUNTY	TOTAL SHEETS	SHEET NO.
2503	16-00313-00-MS	KANE	254	153
CONTRACT NO. 61E18				
ILLINOIS FED. AID PROJECT				

Anthony Dericco

From: Anthony Dericco
Sent: Friday, May 26, 2017 1:08 PM
To: Beth Moesch Chiquito (elizabethn.moesch@comed.com)
Subject: Broadway Ave (IL25)/ATC Aurora
Attachments: ComEdServiceApplication.doc

Beth,

It was a pleasure meeting you on site yesterday to confirm the proposed single phase service location for the proposed street lighting controller.

Just as a recap, a new single phase 100A-120/240V service is available at the northwest corner of Broadway Ave and the main entrance into the Aurora Transportation Center to power a proposed lighting controller to be installed in Spring 2018.

At this location is an existing transformer pole #46222E1. As discussed, the existing overhead electric lines along the west side of Broadway are proposed to be undergrounded later this year. We understand that since our project will be constructed after the undergrounding, further coordination with ComEd's undergrounding designers will need to be performed to accommodate (and provide provisions for) the proposed lighting service.

Attached is the Service and Meter Application for the proposed lighting for your use.

Also, you should receive notice from ComEd New Business soon for a proposed single phase traffic signal service at that same location that will be constructed along with the street lighting improvements. We understand that the proposed service for the traffic signal will be from the same transformer as the lighting.

Thanks, Tony

Anthony J. DeRicco, PE, LEED AP, LC
Head, Electrical Section
Christopher B. Burke Engineering, Ltd.
9575 W. Higgins Road, Suite 600 Rosemont, IL 60018
Phone: (847) 823-0500 Fax: (847) 939-5214
E-Mail: adericco@cbbel.com
www.cbbel.com

COMED CONTACT:

The information contained in this e-mail is intended only for the individual or entity to whom it is addressed and should not be opened, read or utilized by any other party. This message shall not be construed as official project information or as direction except as expressly provided in the contract document. Its contents (including any attachments) may contain confidential and/or privileged information. If you are not an intended recipient you must not use, disclose, disseminate, copy or print its contents. If you receive this e-mail in error, please notify the sender by reply e-mail and delete and destroy the message.

BETH MOESCH CHIQUITO
ELIZABETHN.MOESCH@COMED.COM

COM ED CORRESPONDENCE



Service and Meter Application
Switch and Load Information Sheet

Please complete a separate sheet for each switch - existing or new:

Project Name: Broadway Ave. (IL25) Street Lighting Improvements
Site Address: 360 N. Broadway Ave., Aurora, IL 60505
Switch Name and Location:

Service Voltage (check one):
[ ] 120/240V 1-phase, 3-wire [ ] 277/480V 3-phase, 4-wire
[ ] 120/240V 3-phase, 4-wire [ ] 480V 3-phase 3-wire (B-phase Grounded)
[ ] 120/208V 3-phase, 4-wire [ ] 480V 3-phase 3-wire (Ungrounded - requires ground detection equip.)
[ ] Other:
[ ] 4kV [ ] 12kV [ ] 34kV 3-phase, 3-wire
[ ] 4kV [ ] 12kV [ ] 3-phase, 4-wire

Other Items (check all that apply):
[ ] New Construction Sq. Ft. [ ] Underground Service
[ ] Building Addition Sq. Ft. [ ] Overhead Service
[ ] Relocating Existing Service Entrance Commercial - No. of units Sq. Ft.
[ ] Hi-Rise/ Vault Service Residential - No. of units Sq. Ft.

Date of Ground Breaking (est.): Date to Final Grade (est.): October 1, 2015
Date to Energize: March, 1, 2018 Hours of Operation Per Day: [ ] 3 [ ] 12 [ ] 16 [ ] 24

Switch Size (amps): 100 (If switchgear is 1,200 Amps or larger, customer must submit drawings for ComEd approval)
Switch Rating (percentage): 80%
Secondary Conductors: 1 Sets of 3 /C #2 [ ] CU or [ ] AL
(No. of conductors) (Size) (Type)

Table with 3 columns: (KW or HP), Description, Connected Load (1-phase, 3-phase). Rows include Lighting, VAC, Receptacle, Process Heat, Water Heat, Space Heat, Motors, Welders, and TOTAL LOAD.

Table with 8 columns: Description, Quantity, Size (HP), Efficiency Rating, Phase / Voltage, Nema Code, Starts Per Hr. or Day, Starting Amps, Use.

Table with 8 columns: Description, Quantity, Size (kVA), Type, Max. Inst. Demand, P.F. at Peak, Welds Per Minute, Cycles Per Weld, Hours Per Day Use.



Service and Meter Application
Project Information Sheet

Project Name: Broadway Ave. (IL25) Lighting Improvements
Site Address: 360 N. Broadway Ave(IL25) City: Aurora Zip: 60505

Total Number of Service Entrance Locations (meters/switches) Requested: 1

Legal Name of Entity (Electric Consumer): Village of Rosemont
[ ] Corporation [ ] Partnership [ ] Sole Proprietor [ ] Other: Municipality
Tax I.D.: Existing Account Number: 2733067271

Principle(s) to Sign Contracts For Service, Easements, Etc.:

Property Owner: Phone:
Building Owner: Phone:
Building Manager: Scott Miller Phone: 630-256-3821

Mailing Address For Contracts:

Company: City of Aurora Phone: 630-256-3200 Fax:
Address: 44 E. Downer Place City: Aurora Zip: 60505

Mailing Address For Electric Bills:

Company: City of Aurora Phone: 630-256-3200 Fax:
Address: 44 E. Downer Place City: Aurora Zip: 60505

Project Contacts:

Consulting Engineer: Anthony DeRicco E-mail: adericco@cbbel.com
Firm Name: Christopher Burke Engineering, Ltd. Phone: (847) 823-0500 Fax: (847) 823-0520
Address: 9575 W. Higgins Road, Suite 600 City: Rosemont Zip: 60018

Electrical Contractor:

Consulting Engineer: E-mail:
Firm Name: Phone: Fax:
Address: City: Zip:

Other:

Consulting Engineer: E-mail:
Firm Name: Phone: Fax:
Address: City: Zip:

The Following Documents May Be Required:

- 1. Plat of Survey with legal description of property (for easement, if required)
2. Site Plan showing building relative to property lines - mark service entrance location(s)
3. Civil drawings (showing water, sewer, gas, phone, electric, pavement, grading, etc.)
4. Complete electrical drawings and/or load detail sheets

Information Provided By:

Print Name: Anthony DeRicco
Signature:
Date: May 26, 2017

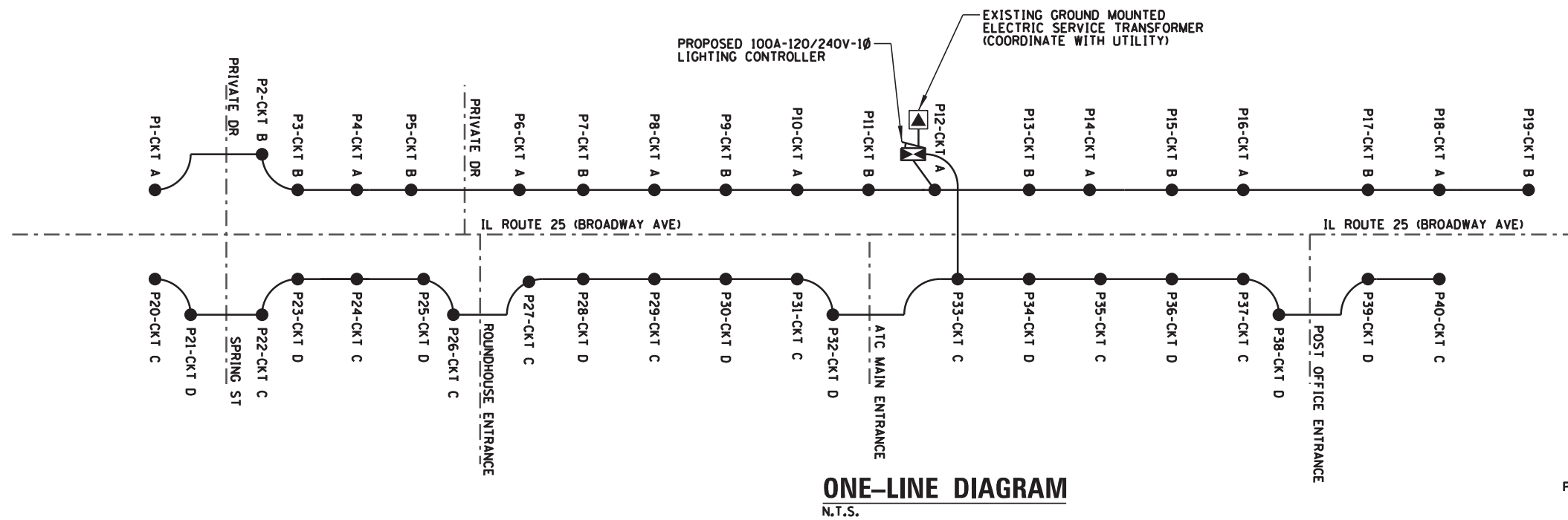

**ONE-LINE DIAGRAM**  
N.T.S.

**ONE-LINE LEGEND**

- PROPOSED LIGHT POLE
- ELECTRIC CABLE IN CONDUIT
- ⊞ LIGHTING CONTROLLER
- ⊠ ELECTRIC SERVICE TRANSFORMER
- HANDHOLE
- POLE NUMBER
- P1-CKT A — ROADWAY CIRCUIT IDENTIFIER
- - - CENTERLINE OF ROADWAY

FILE NAME = N:\WBK\150077.2\Mech\LD1.150077.2-08.sht	USER NAME = odericco	DESIGNED - AJD	REVISED -
Default	PLOT SCALE = 2'	CHECKED - AJD	REVISED -
	PLOT DATE = 10/16/2017	DATE - 10/16/2017	REVISED -

**STATE OF ILLINOIS  
DEPARTMENT OF TRANSPORTATION**

**AURORA TRANSIT CENTER IMPROVEMENTS  
ROADWAY LIGHTING DETAILS (8 OF 8)**

SCALE: **N.T.S.** SHEET OF 254 SHEETS STA. TO STA.

F.A.U. RTE.	SECTION	COUNTY	TOTAL SHEETS	SHEET NO.
2503	16-00313-00-MS	KANE	254	155
<b>CONTRACT NO. 61E18</b>				
ILLINOIS FED. AID PROJECT				

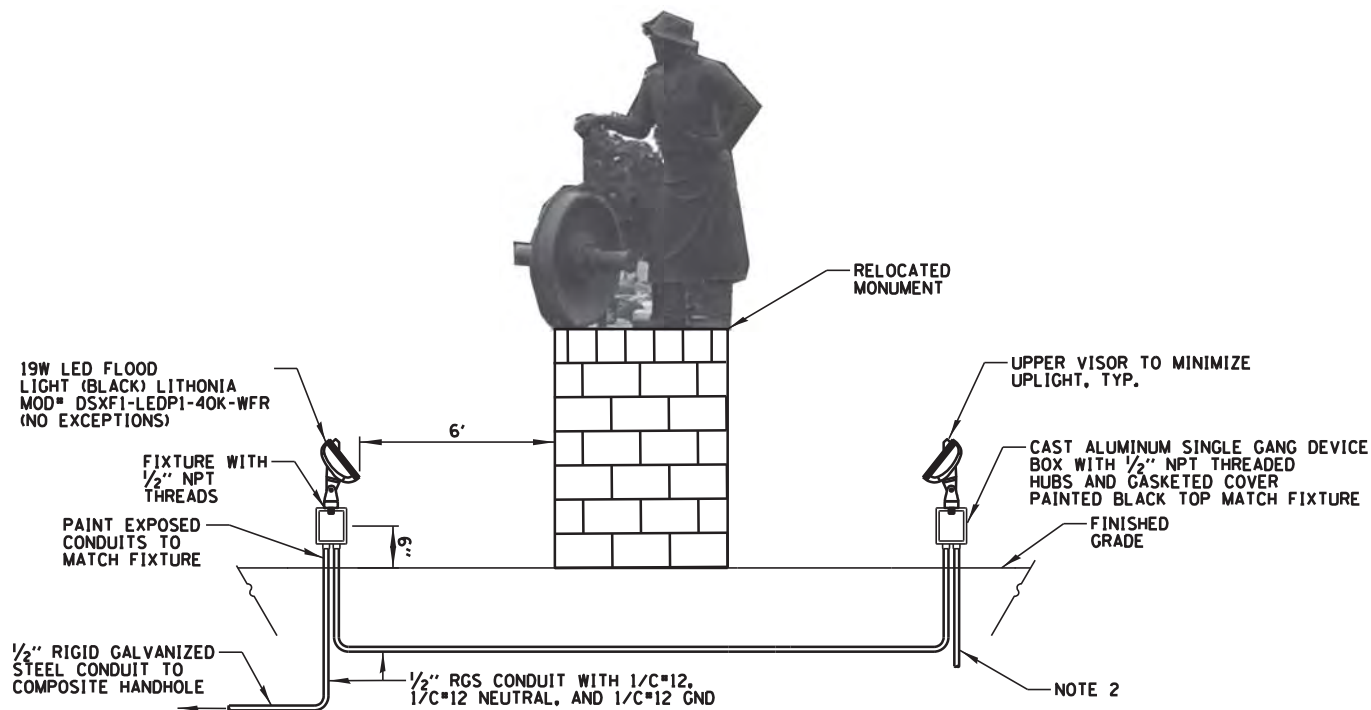

**NOTES:**

1. CONTRACTOR SHALL COORDINATE FIXTURE AIMING WITH OWNER.
2. END OF RUN BOXES HAVE A VERTICAL 1/2" RGS CONDUIT EMBEDDED A MINIMUM OF 30" BELOW GRADE FOR STABILIZATION.
3. LIGHT FIXTURES, JUNCTION BOXES, RIGID GALVANIZED STEEL CONDUITS & #12 AWG WIRING PAID FOR UNDER "SIGN LIGHTING UNIT COMPLETE", SEE SPECIAL PROVISION.

**MONUMENT FLOOD LIGHT DETAIL**

N.T.S.

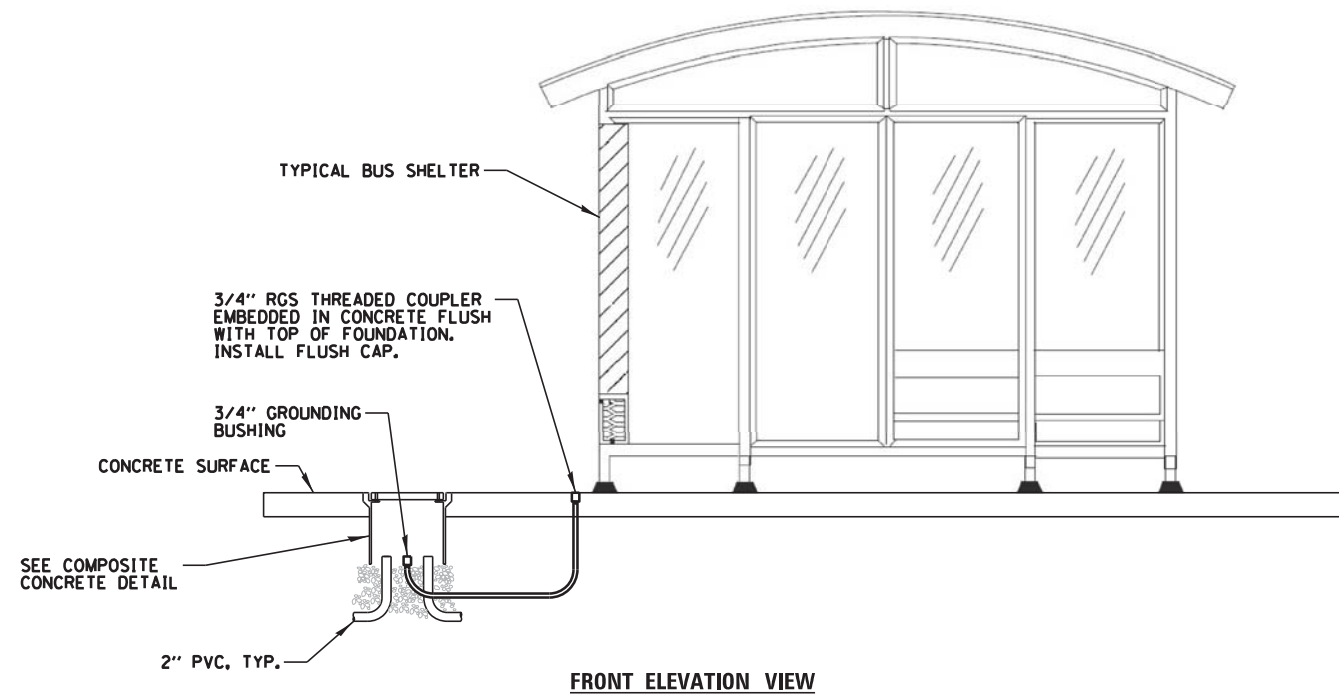

**FRONT ELEVATION VIEW**

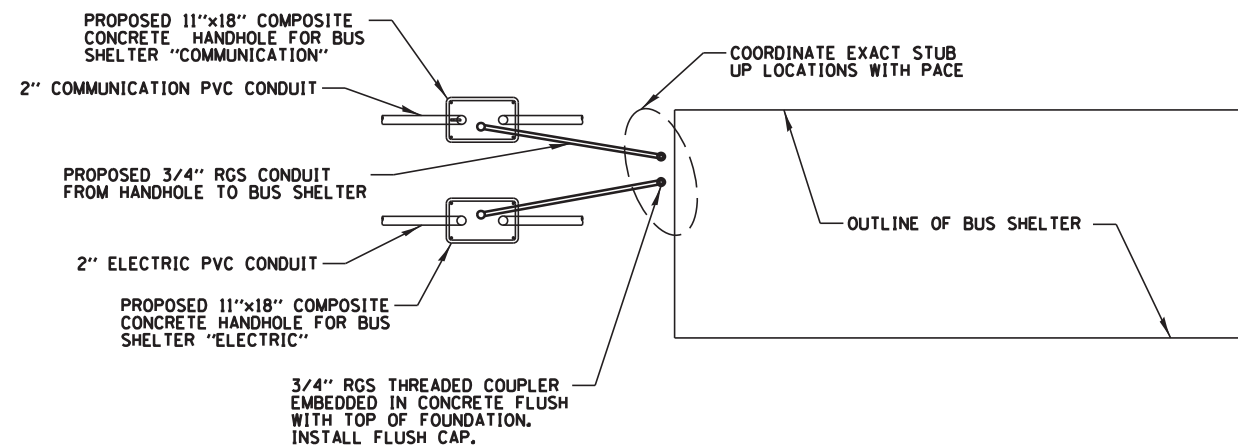

**PLAN VIEW**

**NOTES:**

1. THE RIGID GALVANIZED STEEL CONDUITS (AND FITTINGS) FROM HANDHOLE TO SHELTER SHALL BE PAID FOR UNDER "MISCELLANEOUS ELECTRICAL WORK" (SEE SPECIAL PROVISION.) THE HANDHOLES AND PVC CONDUITS SHALL BE PAID FOR SEPARATELY.

**BUS SHELTER CONDUIT DETAIL**

N.T.S.

FILE NAME =	USER NAME = aderico	DESIGNED -	AJD	REVISED -	
N:\WBK\150077.2\Mech\SLDT_150077.2-01.sh		DRAWN -	JRB	REVISED -	
Default	PLOT SCALE = 4'	CHECKED -	AJD	REVISED -	
	PLOT DATE = 10/16/2017	DATE -	10/16/2017	REVISED -	

STATE OF ILLINOIS  
DEPARTMENT OF TRANSPORTATION

AURORA TRANSIT CENTER IMPROVEMENTS  
PARKING LOT LIGHTING - ELECTRICAL DETAILS (1 OF 4)

SCALE: N.T.S. SHEET OF 254 SHEETS STA. TO STA.

F.A.U. RTE.	SECTION	COUNTY	TOTAL SHEETS	SHEET NO.
2503	16-00313-00-MS	KANE	254	156
CONTRACT NO. 61E18				
ILLINOIS FED. AID PROJECT				



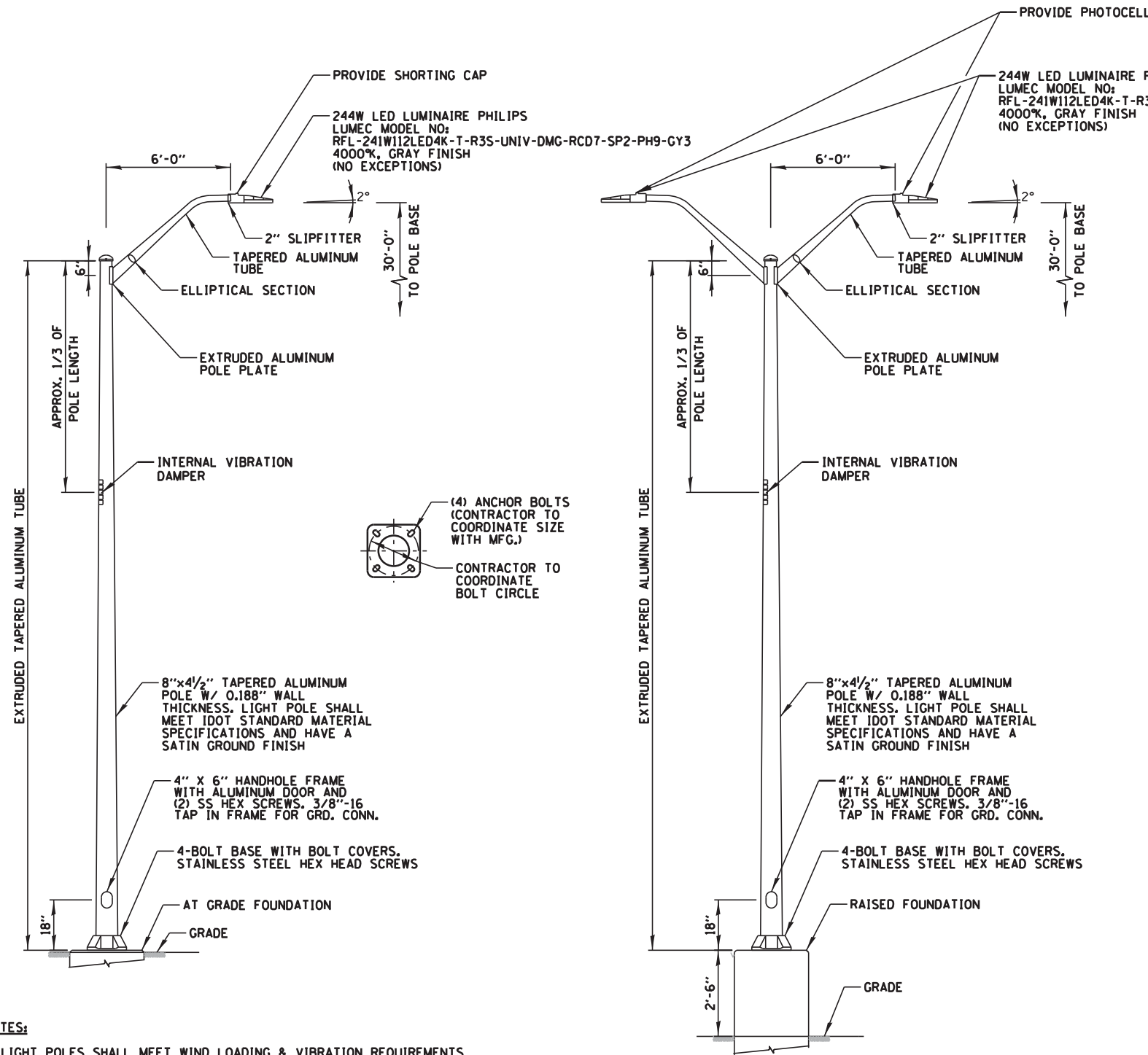

- NOTES:**
1. LIGHT POLES SHALL MEET WIND LOADING & VIBRATION REQUIREMENTS ACCORDING TO THE LATEST AASHTO STANDARDS AND ARTICLE 1069.01 IN STANDARD SPECIFICATIONS FOR ROAD AND BRIDGE CONSTRUCTION.
  2. POLE HANDHOLE SHALL FACE AWAY FROM TRAFFIC.
  3. POLE PAID FOR UNDER "LIGHTPOLE, ALUMINUM, 30 FT. M.H., 6 FT. MAST ARM". LED LUMINAIRE PAD FOR UNDER "LUMINAIRE, LED, HORIZONTAL MOUNT, HIGH WATTAGE", SEE SPECIAL PROVISION.

**LIGHTING UNIT TYPE "1"**  
N.T.S.

- NOTES:**
1. LIGHT POLES SHALL MEET WIND LOADING & VIBRATION REQUIREMENTS ACCORDING TO THE LATEST AASHTO STANDARDS AND ARTICLE 1069.01 IN STANDARD SPECIFICATIONS FOR ROAD AND BRIDGE CONSTRUCTION.
  2. POLE HANDHOLE SHALL FACE AWAY FROM TRAFFIC.
  3. POLE PAID FOR UNDER "LIGHT POLE, SPECIAL, 30'", LED LUMINAIRE PAD FOR UNDER "LUMINAIRE, LED, HORIZONTAL MOUNT, HIGH WATTAGE", SEE SPECIAL PROVISION.

**LIGHTING UNIT TYPE "2"**  
N.T.S.

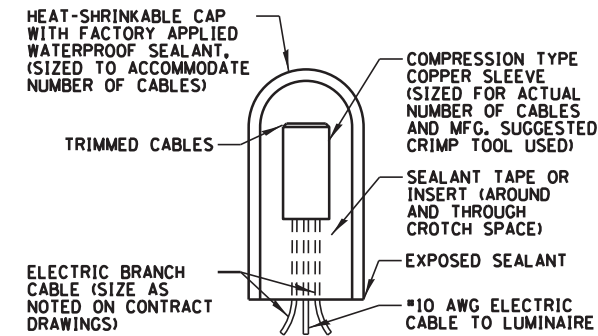

**SPlicing ELECTRIC CABLE**  
N.T.S.

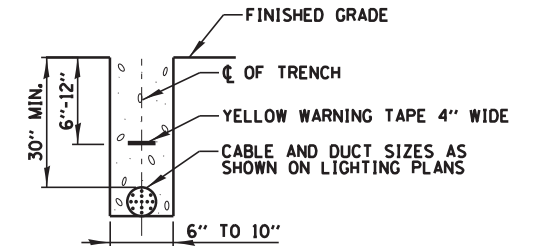

**TRENCH CROSS SECTION**  
N.T.S.

- PHASE CONDUCTOR
- - - GROUND CONDUCTOR
- - - NEUTRAL CONDUCTOR

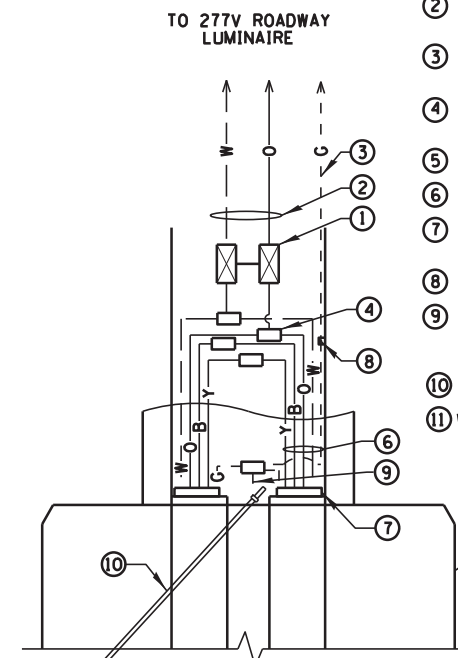

**PARKING LOT LIGHT POLE  
HANDHOLE WIRING DIAGRAM**  
N.T.S.

- 1 5A TIME-DELAY TYPE FUSE INSIDE A 2-POLE WATERPROOF FUSE HOLDER & INSULATING BOOTS (NEUTRAL SHALL BE NON-FUSED) FOR TWIN LUMINAIRES, EACH LUMINAIRE SHALL BE SEPARATELY FUSED
- 2 NO. 10 POLE WIRES TO LUMINAIRE COLOR TO MATCH BRANCH WIRING
- 3 NO. 10 GROUND WIRE CONNECTED TO GROUND LUG IN LUMINAIRE
- 4 MULTIPLE COMPRESSION FITTINGS (SPlice), TYP.
- 5 CONCRETE FOUNDATION
- 6 WIRES AS SHOWN ON PLANS
- 7 PROPOSED LIGHTING DUCT PULLED THROUGH PVC RACEWAY
- 8 POLE GROUND LUG
- 9 NO. 6 GROUND WIRE MECHANICALLY CLAMPED TO GROUND ROD
- 10 GROUND ROD
- 11 WIRE COLOR:  
O - ORANGE  
B - BROWN  
Y - YELLOW  
W - WHITE  
G - GREEN

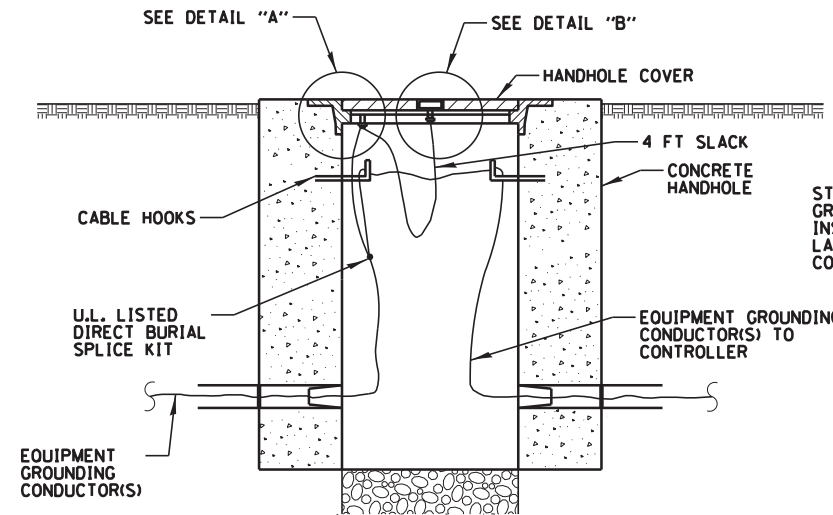

**NOTES:**

1. LIGHTING CONDUCTORS NOT SHOWN FOR CLARITY.
2. BONDING COVER AND FRAME SHALL BE PAID FOR UNDER "GROUNDING EXISTING HANDHOLE FRAME AND COVER."

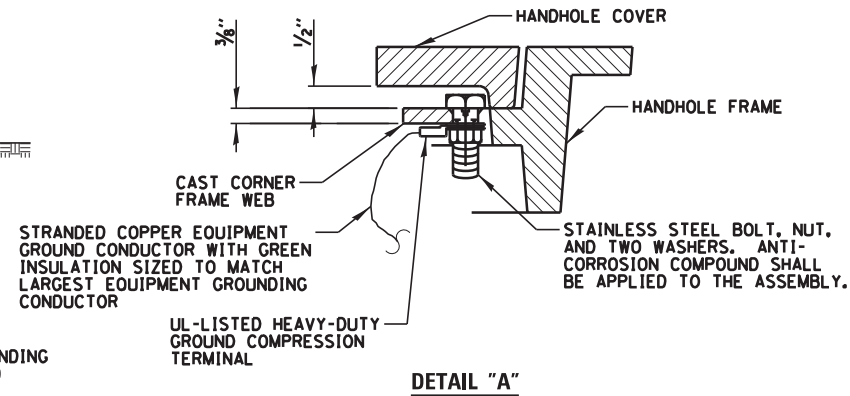

**DETAIL "A"**

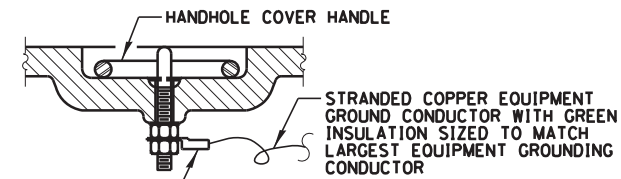

**DETAIL "B"**

UL-LISTED HEAVY-DUTY GROUND COMPRESSION TERMINAL WITH STAINLESS STEEL NUT. ANTI-CORROSION COMPOUND SHALL BE APPLIED TO THE ASSEMBLY.

**BONDING CONCRETE HANDHOLE COVER & FRAME**

N.T.S.

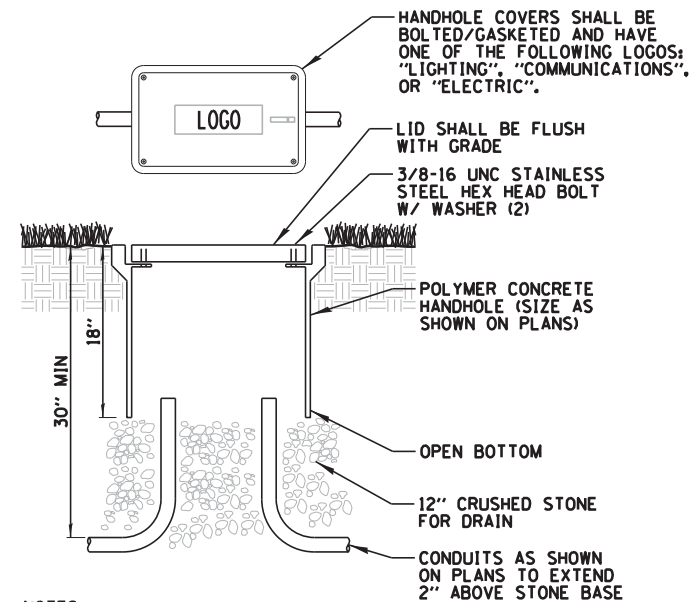

**NOTES:**

1. SPLICES IN HANDHOLE SHALL BE WATERPROOF (SEE DETAIL).
2. POLYMER CONCRETE HANDHOLE AND LID SHALL BE GRAY.
3. BOX & LID SHALL MEET/EXCEED ANSI TIER 15 LOADING REQUIREMENTS, AND BE TESTED IN ACCORDANCE WITH THE LATEST EDITION OF THE ANSI/SCTE 77 "SPECIFICATION FOR UNDERGROUND ENCLOSURE INTEGRITY", AND THE PROVISIONS OF PARAGRAPHS 5.2.3 AND 5.2.4 OF WESTERN UNDERGROUND COMMITTEE GUIDE 3.6.
4. 11"x18"x18" DEEP HANDHOLE PAID FOR UNDER "HANDHOLE, COMPOSITE CONCRETE". (SEE SPECIAL PROVISION)
5. 17"x30"x18" DEEP HANDHOLE PAID FOR UNDER "HANDHOLE, COMPOSITE CONCRETE (SPECIAL)". (SEE SPECIAL PROVISION)

**COMPOSITE CONCRETE HANDHOLE**

N.T.S.

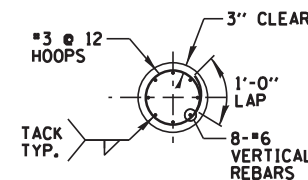

**SECTION A-A**

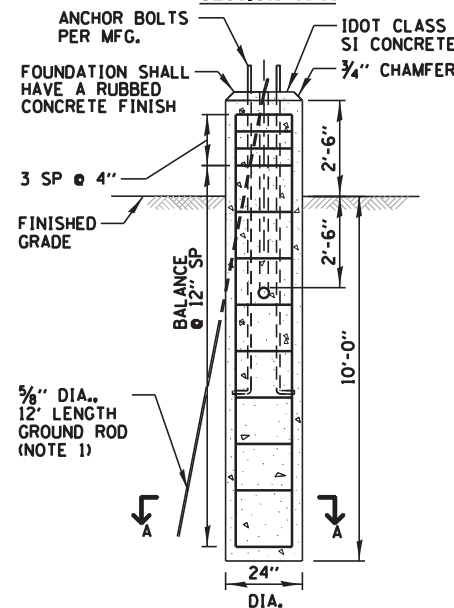

**RAISED FOUNDATION**

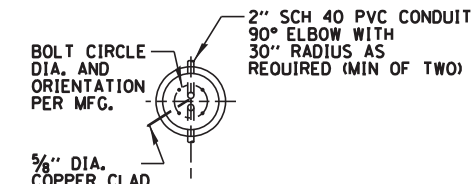

**PLAN**

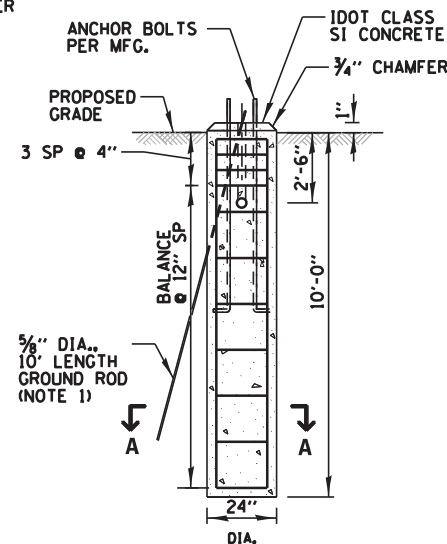

**AT GRADE FOUNDATION**

**NOTES:**

1. GROUND ROD SHALL BE CAST INTO CONCRETE FOUNDATION WITH 8 FEET IN CONTACT WITH SOIL.
2. FOUNDATIONS SHALL BE VIBRATED IN ACCORDANCE WITH IDOT STANDARD PRACTICES.
3. PAID FOR UNDER "LIGHT POLE FOUNDATION, 24" DIAMETER".

**CONCRETE FOUNDATION DETAIL**

N.T.S.

FILE NAME =	USER NAME = adericco	DESIGNED - AJD	REVISED -
N:\WBK\150077.2\Mech\SLDT_150077.2-03.sh		DRAWN - JRB	REVISED -
Default	PLOT SCALE = 2"	CHECKED - AJD	REVISED -
	PLOT DATE = 10/16/2017	DATE - 10/16/2017	REVISED -

STATE OF ILLINOIS  
DEPARTMENT OF TRANSPORTATION

AURORA TRANSIT CENTER IMPROVEMENTS  
PARKING LOT LIGHTING - ELECTRICAL DETAILS (3 OF 4)

SCALE: N.T.S. SHEET OF 254 SHEETS STA. TO STA.

F.A.U. RTÉ.	SECTION	COUNTY	TOTAL SHEETS	SHEET NO.
2503	16-00313-00-MS	KANE	254	158
CONTRACT NO. 61E18				
ILLINOIS FED. AID PROJECT				

EXISTING FESTIVAL PANELBOARD SCHEDULE											
FED FROM: MAIN PB					TOT 'A' PHASE					7200	VA
VOLTAGE: 120/240V, 1 PH, 3W					TOT 'B' PHASE					7200	VA
BUS SIZE: 225					TOTAL 'A' + 'B':					14400	VA
MAINS: 200					TOTAL AMPS:					60.0	A
SPACES: 24											
SHORT CKT RATING: 10KAIC											
BONDING JUMPER: YES											
MOUNTING: SURFACE											
CKT #	CB/ POLES	DESCRIPTION	A PH VA	B PH VA	A PH VA	B PH VA	DESCRIPTION	CB/ POLES	CKT #		
1	100A-2P	DUAL EV CHARGER	3600		3600		DUAL EV CHARGER	100A-2P	2		
3		SPACE		3600		3600	SPACE		4		
5		SPACE					SPACE		6		
7		SPACE					SPACE		8		
9		SPACE					SPACE		10		
11		SPACE					SPACE		12		
13		SPACE					SPACE		14		
15		SPACE					SPACE		16		
17		SPACE					SPACE		18		
19		SPACE					SPACE		20		
21		SPACE					SPACE		22		
23		SPACE					SPACE		24		
SUBTOTALS:			3600	3600	3600	3600					

PROPOSED FESTIVAL PANELBOARD SCHEDULE											
FED FROM: MAIN PB					TOT 'A' PHASE					10800	VA
VOLTAGE: 120/240V, 1 PH, 3W					TOT 'B' PHASE					10800	VA
BUS SIZE: 225					TOTAL 'A' + 'B':					21600	VA
MAINS: 200					TOTAL AMPS:					90.0	A
SPACES: 24											
SHORT CKT RATING: 10KAIC											
BONDING JUMPER: YES											
MOUNTING: SURFACE											
CKT #	CB/ POLES	DESCRIPTION	A PH VA	B PH VA	A PH VA	B PH VA	DESCRIPTION	CB/ POLES	CKT #		
1	40A-2P	EV CHARGER #1	3600		3600		EV CHARGER #2	40A-2P	2		
3		SPACE		3600		3600	SPACE		4		
5	40A-2P	EV CHARGER #3	3600				SPACE		6		
7		SPACE		3600			SPACE		8		
9		SPACE					SPACE		10		
11		SPACE					SPACE		12		
13		SPACE					SPACE		14		
15		SPACE					SPACE		16		
17		SPACE					SPACE		18		
19		SPACE					SPACE		20		
21		SPACE					SPACE		22		
23		SPACE					SPACE		24		
SUBTOTALS:			7200	7200	3600	3600					

**NOTES:**

- REMOVE THE TWO EXISTING 100A-2P CIRCUIT BREAKERS AND DISPOSE OF.
- FURNISH AND INSTALL THREE 40A-2P CIRCUIT BREAKERS.
- FOUR NEW 2" PVC CONDUITS ARE PROPOSED TO BE CONNECTED TO THIS PANEL. THIS WORK SHALL INCLUDE THE RGS (ABOVE GRADE) PORTION THAT CONNECTS TO THIS PANEL.
- THIS WORK SHALL BE PAID FOR UNDER "MODIFY EXISTING CABINET EQUIPMENT AND APPURTENANCES", (SEE SPECIAL PROVISION).

**FESTIVAL PANEL UPGRADES**

N.T.S.

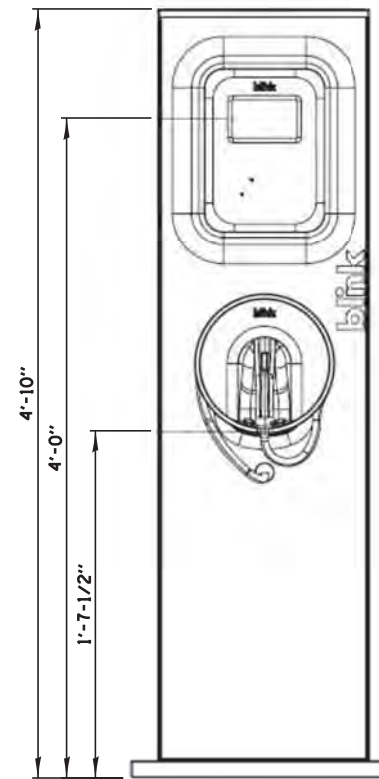
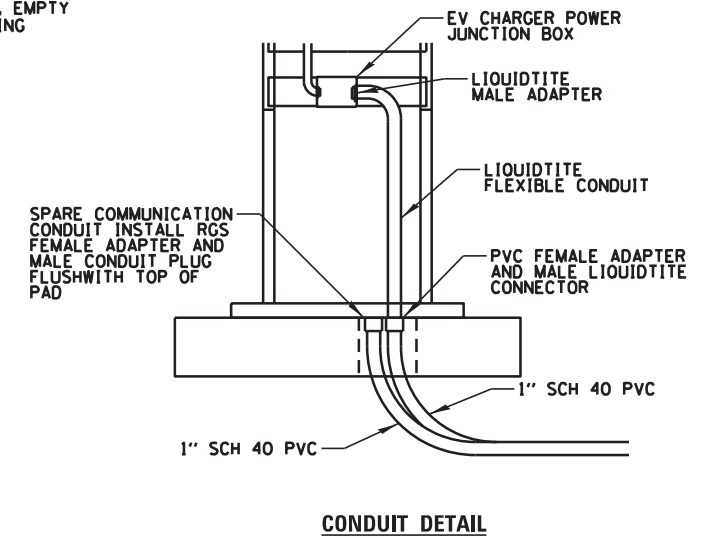
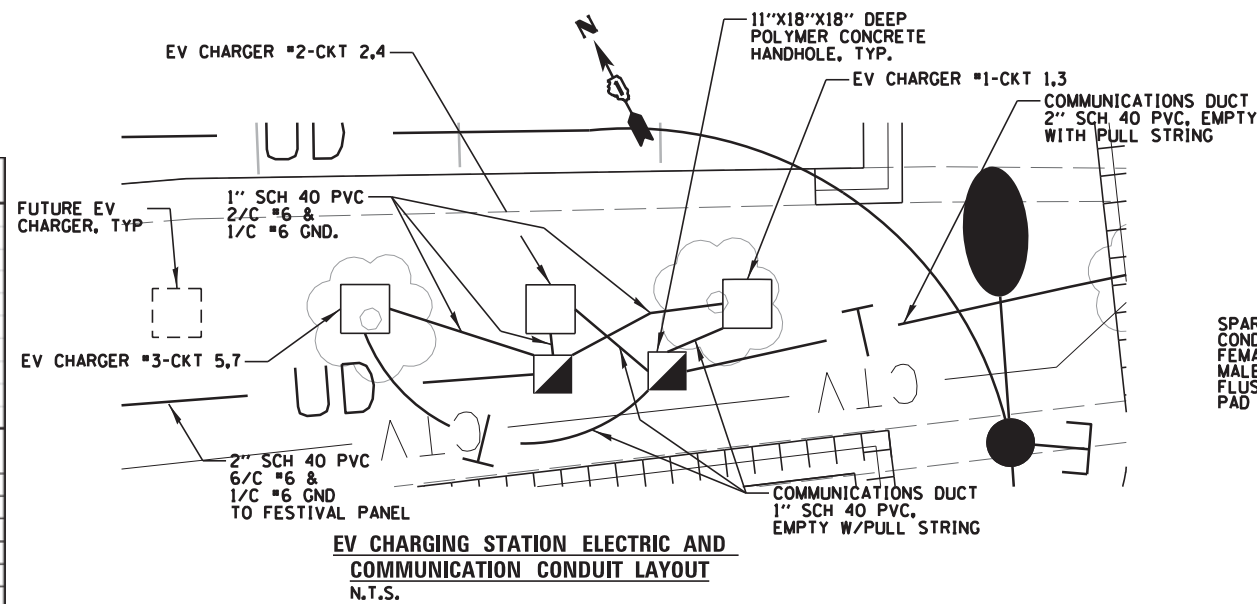

EV CHARGING STATION PROFILE

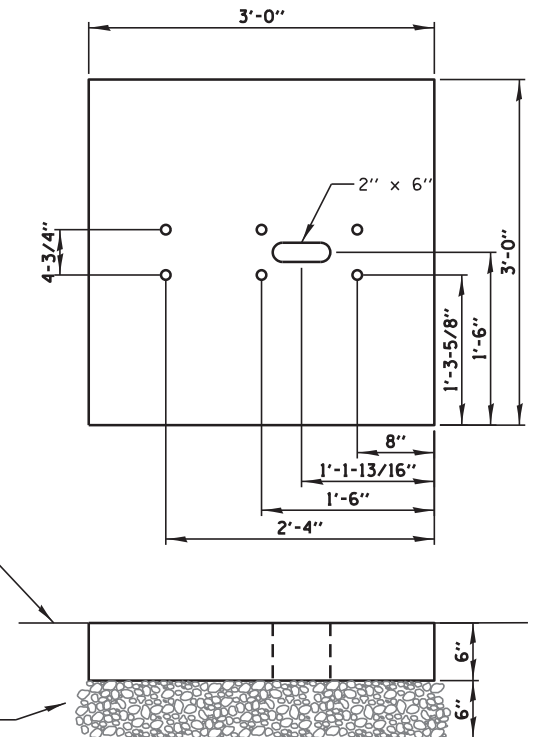

EV CHARGER CONCRETE PAD

**NOTES:**

- EV CHARGER SHALL BE LEVEL 2 COMMERCIAL 48" HIGH PEDESTAL TYPE BLINK MODEL NO. PE-30KICE48.
- CHARGER SHALL BE CONNECTED TO THE BLINK NETWORK VIA CELLULAR MODEM.
- THIS WORK SHALL INCLUDE ALL WORK SHOWN ABOVE (INCLUDING EV CHARGER, CONCRETE PAD, HARDWARE, FASTENERS, INTERIOR CONDUIT/CONNECTORS, ETC).
- THIS WORK SHALL BE PAID FOR UNDER "POWER PEDESTALS", (SEE SPECIAL PROVISION).

**EV CHARGING STATION DETAILS**

N.T.S.

NOTES:

1. ALL STATION AND OFFSETS ARE REFERENCED TO THE PARKING LOT X BASELINE UNLESS OTHERWISE NOTED.
2. SEE DETAIL SHEET 241 FOR LIGHT POLE FOUNDATION, SPECIAL DETAIL.

**CONDUCTOR SCHEDULE**

2 3/C #8 & 1/C #8 GND XLP-TYPE USE CABLES

**CONDUIT SCHEDULE**

A 2" Ø SCH 80 PVC OR HDPE CONDUIT

C 2 1/2" Ø SCH 80 PVC OR HDPE CONDUIT

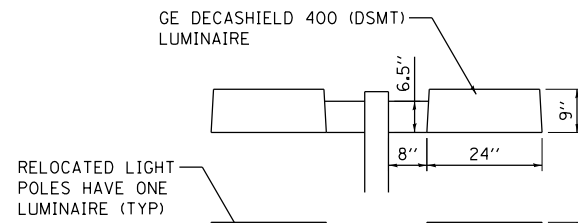

RELOCATED LIGHT POLES HAVE ONE LUMINAIRE (TYP)

**LUMINAIRE**

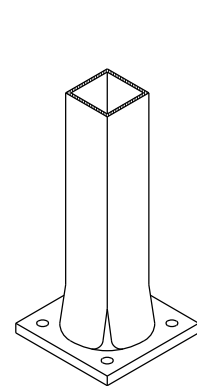

**ISOMETRIC VIEW**

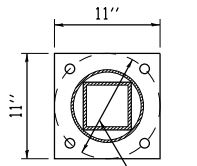

**TOP VIEW**

BOLT CIRCLE

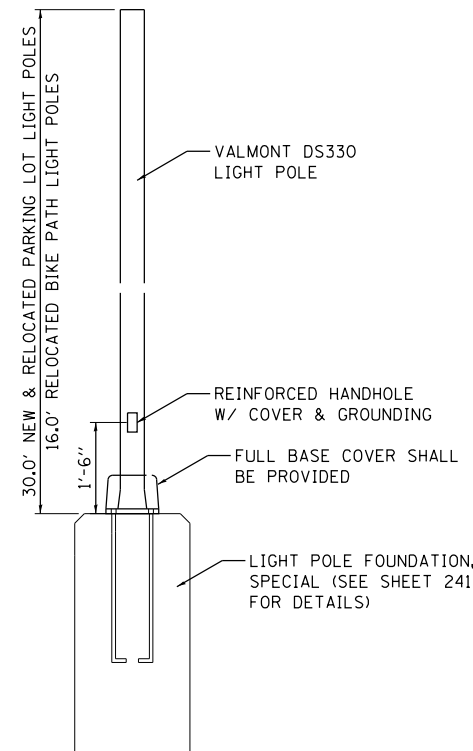

**ELEVATION VIEW**

NOTES

1. ALL LIGHT POLES (NEW AND RELOCATED) SHALL BE INSTALLED ON NEW LIGHT POLE FOUNDATION. SEE DETAIL SHEET 241.
2. THE CONSTRUCTOR SHALL INSTALL THE LIGHT POLES AND LUMINAIRES PER MANUFACTURER SPECIFICATIONS.

**LIGHT POLE, SPECIAL DETAIL**

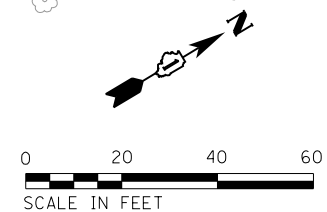
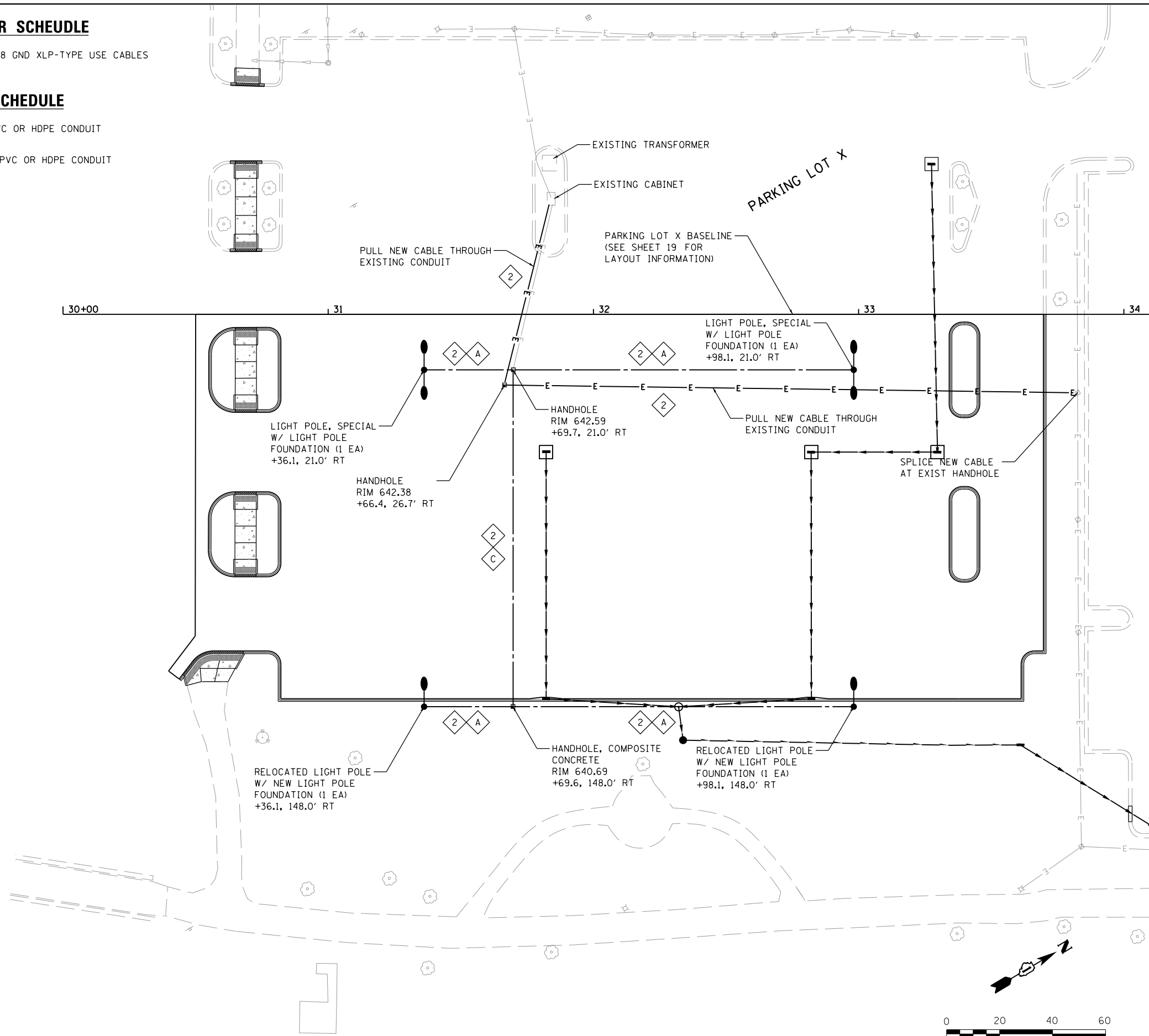

FILE NAME = W:\Projects\2016\160194\_ATCPhaseII\Cadd\Civil\Dgn\Shd\LT\_01.dgn

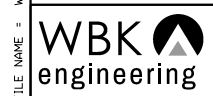

**WBK ENGINEERING, LLC**  
116 WEST MAIN STREET, SUITE 201  
ST. CHARLES, ILLINOIS 60174  
(630) 443-7755

USER NAME = nparris  
PLOT SCALE = 1:40  
PLOT DATE = 11/8/2017

DESIGNED - MNB	REVISED -
DRAWN - NDP	REVISED -
CHECKED - MNB	REVISED -
DATE - 10/18/17	REVISED -

**STATE OF ILLINOIS  
DEPARTMENT OF TRANSPORTATION**

**PARKING LOT X  
LIGHTING PLAN**  
SCALE: 1"=20'  
SHEET NO. 25 OF 26 SHEETS STA. TO STA.

F.A.U. RTE.	SECTION	COUNTY	TOTAL SHEETS	SHEET NO.
2503	16-00313-00-MS	KANE	254	160
CONTRACT NO. 61E18				
ILLINOIS FED. AID PROJECT				

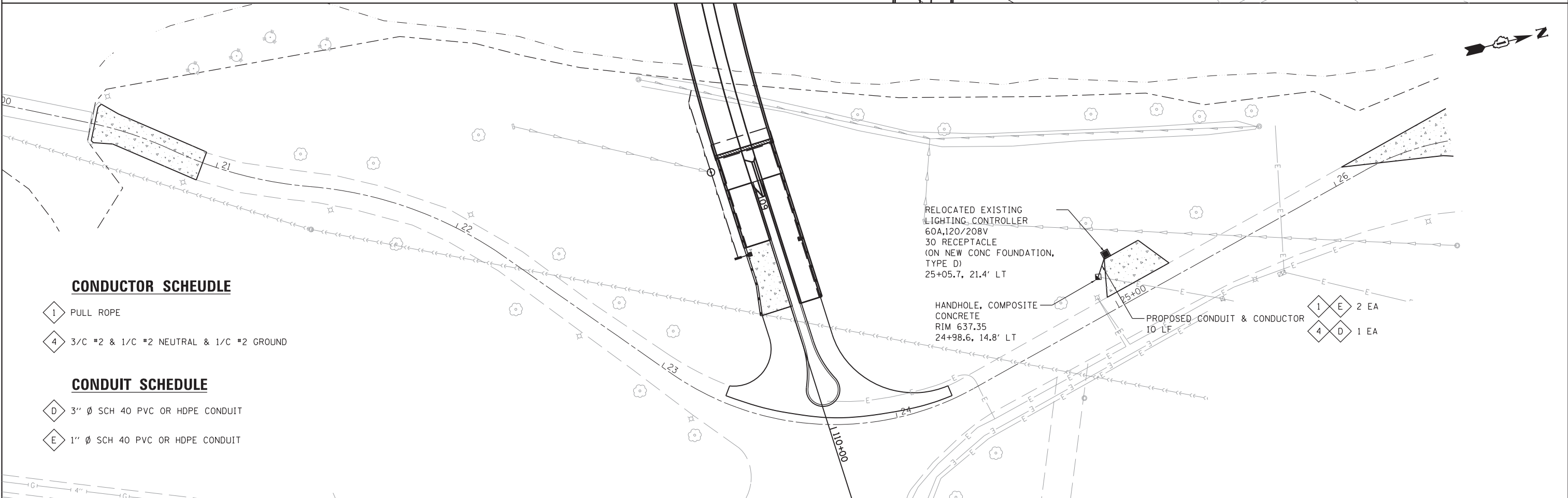
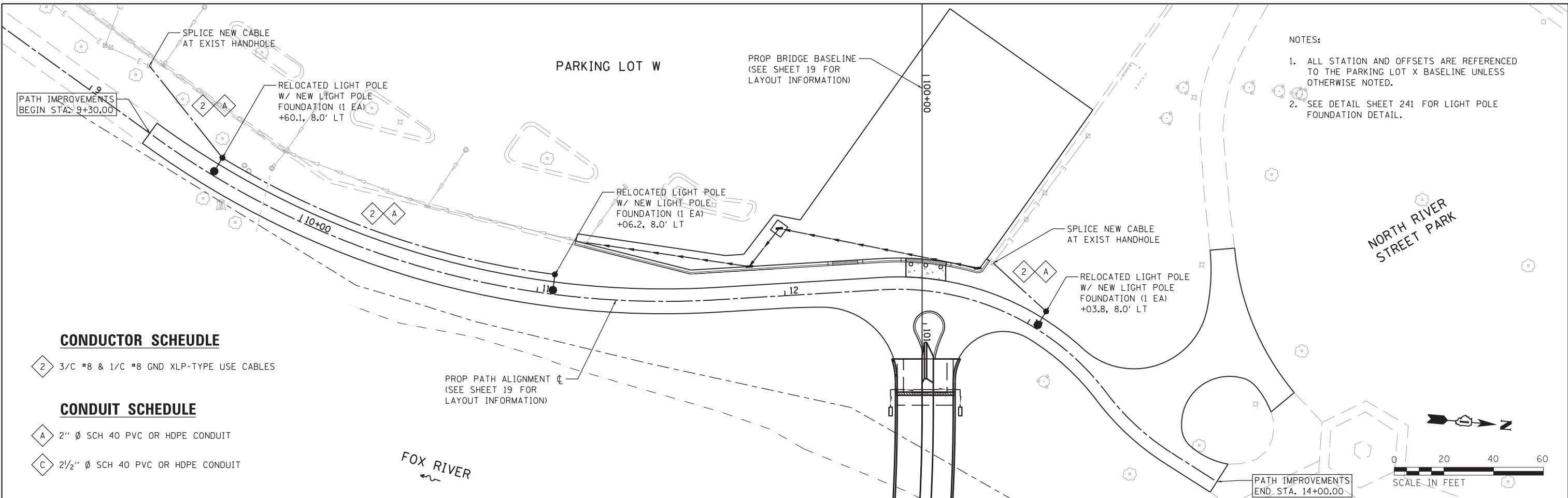

	WBK ENGINEERING, LLC 116 WEST MAIN STREET, SUITE 201 ST. CHARLES, ILLINOIS 60174 (630) 443-7755	USER NAME = nparris PLOT SCALE = 1/4"=1'-0" PLOT DATE = 10/17/2017	DESIGNED - MNB DRAWN - NDP CHECKED - MNB DATE - 10/18/17	REVISED - REVISED - REVISED - REVISED -	STATE OF ILLINOIS DEPARTMENT OF TRANSPORTATION	MULTI-USE PATH LIGHTING PLAN SCALE: 1"=20' SHEET NO. 2 OF 2 SHEETS STA. TO STA.	F.A.U. RTE. 2503 SECTION 16-00313-00-MS COUNTY KANE TOTAL SHEETS 254 SHEET NO. 161 CONTRACT NO. 61E18 ILLINOIS FED. AID PROJECT
--	--	--	---	--	---	---	---

Bench Mark: Aurora Benchmark #13N. N: 1857347.747, E: 991419.405; Elev. = 638.39

Existing Structure: None

**DESIGN STRESSES**

FIELD UNITS:  
 f'c = 6,000 psi (Superstructure)  
 f'c = 4,000 psi (Substructure)  
 fy = 60,000 psi (Reinforcement)

**DESIGN LOADING**

Pedestrian Live Load: 90 PSF  
 Truck Loads: H-10  
 Future Wearing Surface: 12.5 PSF  
 Snow Load: 4' @ 20 PCF  
 Ice Flow: 18" Depth  
 Temp. Range = 0° F - 80° F  
 Ambient Temp. = 50° F

**DESIGN SPECIFICATIONS**

2014 AASHTO LRFD Bridge Design Specifications 7th Ed., with 2015 and 2016 Interims.  
 2009 AASHTO LRFD Guide Specifications for Design of Pedestrian Bridges, with 2015 Interims.  
 Ductility Factor:  $\eta_D = 1.0$   
 Importance Factor:  $\eta_I = 0.95$   
 Redundancy Factor:  $\eta_R = 1.05$

**SEISMIC DATA**

Seismic Performance Zone (SPZ) = 1  
 Design Spectral Acceleration at 1.0 sec. ( $S_{D1}$ ) = 0.064  
 Design Spectral Acceleration at 0.2 sec. ( $S_{D5}$ ) = 0.123  
 Soil Site Class = C

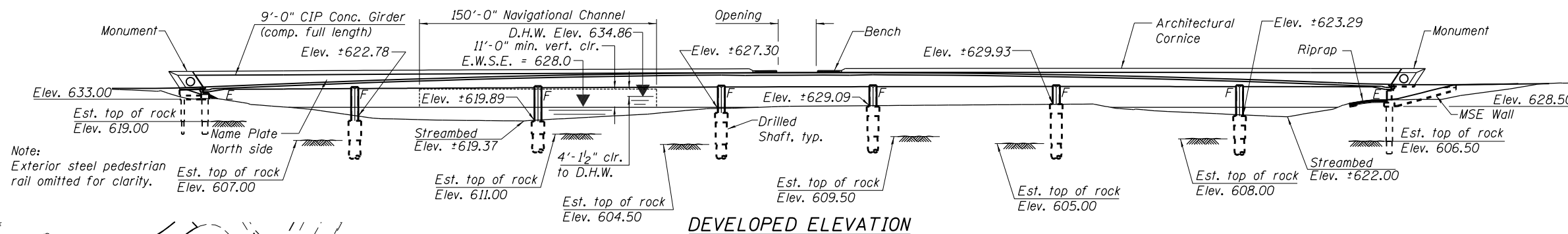

Note:  
 Exterior steel pedestrian rail omitted for clarity.

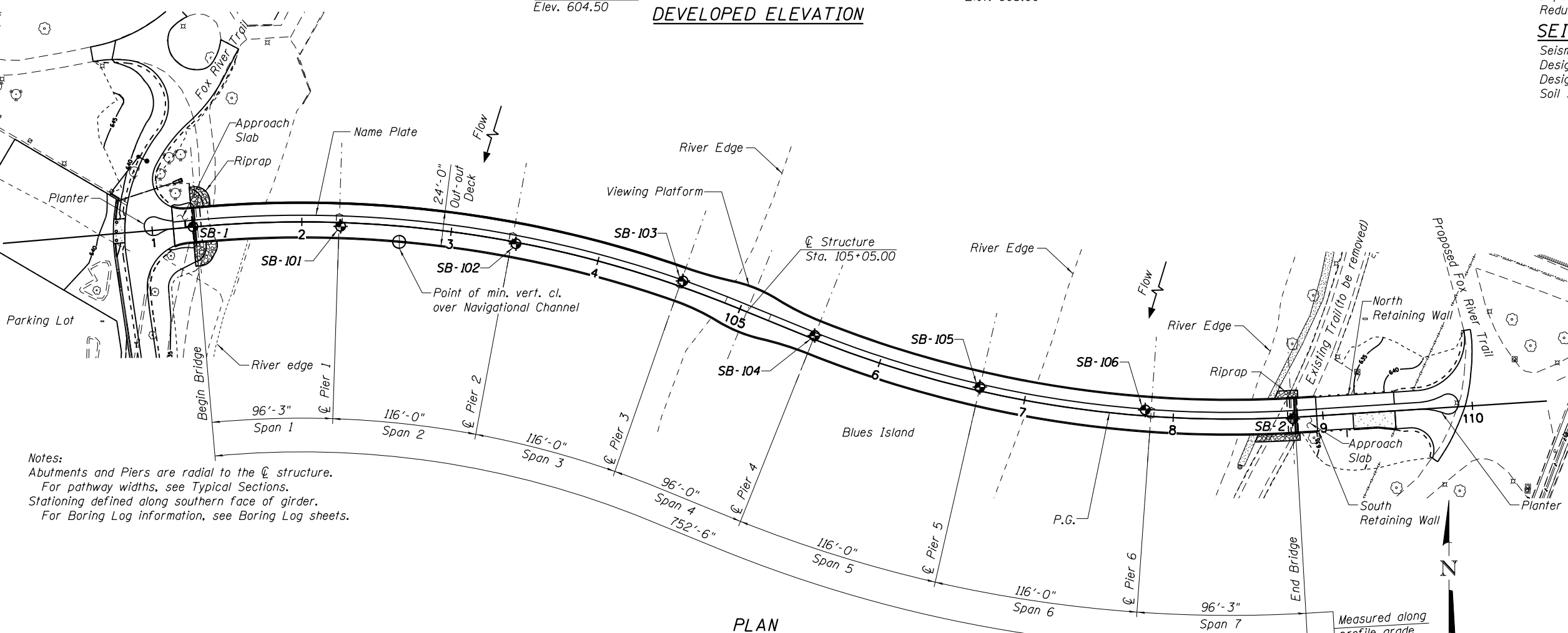

Notes:  
 Abutments and Piers are radial to the  $\odot$  structure.  
 For pathway widths, see Typical Sections.  
 Stationing defined along southern face of girder.  
 For Boring Log information, see Boring Log sheets.

**DESIGN SCOUR ELEVATION TABLE**

Event/Limit State	Design Scour Elevations (ft.)								Item 113
	W. Abut.	Pier 1	Pier 2	Pier 3	Pier 4	Pier 5	Pier 6	E. Abut.	
Q100									5
Q500	623.90	619.50	619.00	617.50	618.00	619.00	612.50	619.50	
Design Check									

Pier scour elevations are to top of weathered rock.  
 Top of rock elevation shown in elevation view is to top of competent rock.

**WATERWAY INFORMATION**

Drainage Area = 1,705 mi <sup>2</sup>		Exist. Low Grade Elev. N/A @ Sta. 105+05.00		Prop. Low Grade Elev. 639.38 @ Sta. 102+66.00					
Flood	Freq. Yr.	Q C.F.S.	Opening Sq. Ft.		Head - Ft.		Headwater El.		
			Exist.	Prop.	Exist.	Prop.	Exist.	Prop.	
	10	12,100	-	5,353	633.60	-	0.04	-	633.64
	30	15,000	-	5,903	634.34	-	0.04	-	633.38
Design	50	17,000	-	6,289	634.86	-	0.04	-	634.90
Base	100	18,600	-	6,594	635.27	-	0.04	-	635.31
Max. Calc.	500	24,100	-	7,580	636.34	-	0.04	-	636.38

10 year velocity through existing bridge = N/A  
 10 year velocity through prop. bridge = 1.32 fps

I certify that to the best of my knowledge, information, and belief, this bridge design is structurally adequate for the design loading shown on the plans. The design complies with requirements of the current "AASHTO LRFD Bridge Design Specifications".



Signed *Phillip D. Frey*  
 Phillip D. Frey, S.E. II, Lic. No. 081-004826  
 Expires 11-30-2018  
 Date 10/12/2017

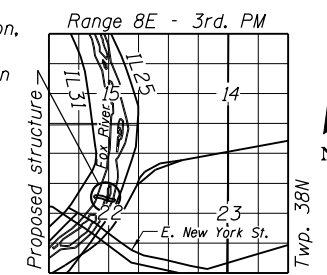

FILE NAME = 045P008-XXXX-001-CENPLAN&E.L.dgn

**GENERAL NOTES**

All reinforcement bars shall be epoxy coated. Reinforcement bars shall conform to the requirements of AASHTO M-31 (ASTM A706, Grade 60, Deformed bars).

All structural steel shall be AASHTO M 270 Grade 50W except expansion joint which shall be AASHTO M 270 Grade 50.

Layout of the slope protection system may be varied to suit ground conditions in the field as directed by the Engineer.

The Contractor shall obtain a construction permit from the Illinois Department of Natural Resources (IDNR), Office of Water Resources for any temporary construction activity placed in the water except cofferdams. This shall include the placement of material for run-arounds, causeways, etc. Any permit application by the Contractor shall refer to the IDNR 3704 Floodway Construction permit number allowing permanent construction as shown in the contract plans.

The Contractor shall make allowance for the deflection of forms, shrinkage and settlement of falsework, in addition to allowance for dead load deflection. Forms for deck slab shall be removed prior to placement of bridge approach slab.

Fasteners shall be ASTM A325 Type 1, mechanically galvanized bolts.

No field welding is permitted except as specified in the contract documents.

The organic Zinc Rich Primer/ Epoxy/ Urethane Paint System shall be used for painting of railing components and expansion joint cover plate. The entire system shall be shop applied, with the exception of masked off connection surfaces, field installed fasteners and damaged areas shall be touched up in the field. The color of the final finish coat for all steel components shall be blue gray Federal Color No. 25042.

Reinforcement bar bending details shall be in accordance with the latest ACI Manual of Concrete Practice.

Reinforcement bar bending dimensions are out to out.

Cover from the face of concrete to face of reinforcement bars shall be 3" for surfaces formed against earth and 2 inches for all other surfaces unless otherwise shown.

Bridge seat reinforcements shall be carefully placed as detailed in the plans to avoid interference with drilling holes for anchor rods.

Painting of new structural steel shall be accomplished in accordance with Section 506 of the Standard Specifications except field-applying intermediate and final coats of paint on new steel shall not be allowed.

Prior to placement of the joint block-out, the contractor shall coordinate with the Modular Joint Manufacturer to ensure the joint will be properly supported and the reinforcement bars will not interfere with the joint components. Any necessary adjustments to the reinforcement layout shall be submitted to the Engineer for approval.

Contractor shall not scale dimension from the Contract Plans for construction purposes. Scales shown are for information only.

No construction joints except those shown on the plans will be allowed unless approved by the Engineer.

It shall be the Contractors responsibility to verify the location of all utilities prior to starting construction. Contact J.U.L.I.E. 800-892-0123

The soil boring logs represent point information. Presentation of the information in no way implies that subsurface conditions are the same at locations other than the exact location of the boring.

**REBAR DESIGNATION**

aa ### (E) (V)  
① ② ③ ④

- ① REBAR TYPE CODE. One or two letters designating bar type or location.
- ② Unique number. One, two, or three digit bar identification code. Unique for each set of bars within each type code.
- ③ Epoxy designator. Optional, indicates bars to be epoxy coated.
- ④ Variable dimension designator. Optional, indicates one or more dimensions of the bar shape is variable within the group. When this occurs the bar list will contain two entries, one for the minimum length and one for the maximum length. the number of bars assigned to each will be proportioned such that the total length is accurate.

**REBAR TYPE CODES**

- a- Transverse Deck Reinforcement
- at- Additional Top Reinforcement
- ab- Additional Bottom Reinforcement
- b- Longitudinal Deck Reinforcement
- d- Dowel
- g- Longitudinal Girder Reinforcement
- h- Horizontal Bar
- ht- Horizontal Ties
- s- Stirrups
- sp- Spiral
- t- Ties
- u- U-shaped Bars
- v- Vertical Bar
- vt- Vertical Ties

**INDEX OF SHEETS**

- S-1 General Plan & Elevation
- S-2 General Data 1
- S-3 General Data 2
- S-4 Geometry Data
- S-5 Deck Contours
- S-6 Footing Layout
- S-7 Temporary Access Causeway
- S-8 Recommended Construction Sequence 1
- S-9 Recommended Construction Sequence 2
- S-10 Recommended Construction Sequence 3
- S-11 Recommended Construction Sequence 4
- S-12 Superstructure 1
- S-13 Superstructure 2
- S-14 Superstructure Details 1
- S-15 Superstructure Details 2
- S-16 Superstructure Details 3
- S-17 Superstructure Details 4
- S-18 Superstructure Details 5
- S-19 Superstructure Details 6
- S-20 Diaphragm Details 1
- S-21 Diaphragm Details 2
- S-22 Bent Cap Details 1
- S-23 Bent Cap Details 2
- S-24 West Bridge Approach Slab
- S-25 East Bridge Approach Slab
- S-26 Expansion Joint Details 1
- S-27 Expansion Joint Details 2
- S-28 Bearing Details
- S-29 West Abutment Layout
- S-30 West Abutment Details 1
- S-31 West Abutment Details 2
- S-32 East Abutment Layout
- S-33 East Abutment Details 1
- S-34 East Abutment Details 2
- S-35 Pier 1 Details
- S-36 Pier 2 Details
- S-37 Pier 3 Details
- S-38 Pier 4 Details
- S-39 Pier 5 Details
- S-40 Pier 6 Details
- S-41 Bar Splice Assembly & Mechanical Splicer Details
- S-42 Deck Drain Details
- S-43 Railing Layout
- S-44 Railing Details 1
- S-45 Railing Details 2
- S-46 Railing Details 3
- S-47 Railing Details 4
- S-48 Future Utility Details 1
- S-49 Future Utility Details 2
- S-50 Architectural Details 1
- S-51 Architectural Details 2
- S-52 Architectural Details 3
- S-53 Architectural Details 4
- S-54 Bench Details
- S-55 Cornice Details
- S-56 Boring Logs 1
- S-57 Boring Logs 2
- S-58 Boring Logs 3
- S-59 Boring Logs 4
- S-60 Bridge Electric - General Notes
- S-61 Bridge Electric - General Plan
- S-62 Bridge Electric - Schematic Plan
- S-63 Bridge Electric - Controllers and Underground Plan
- S-64 Bridge Electric - Lighting Plan
- S-65 Bridge Electric - Single Line Diagram
- S-66 Bridge Electric - Conduit Details
- S-67 Bridge Electric - Controller Details
- S-68 BE-220. Electric Service Installation Aerial, Remote Disconnect (District 1)
- S-69 BE-702. Misc. Electrical Details Sheet A. (District 1)

**TOTAL BILL OF MATERIAL**

PAY ITEM	UNIT	SUB	SUPER	TOTAL
POROUS GRANULAR BACKFILL	CU YD	53		53
STRUCTURE EXCAVATION	CU YD	68		68
FLOOR DRAINS	EACH		30	30
CONCRETE STRUCTURES	CU YD	173		173
CONCRETE SUPERSTRUCTURE	CU YD		1567	1567
FORM LINER TEXTURED SURFACE	SQ FT	1062		1062
CONCRETE SUPERSTRUCTURE (APPROACH SLAB)	CU YD		33	33
REINFORCEMENT BARS, EPOXY COATED	POUND	161657	427575	589232
BAR SPLICERS	EACH	72		72
PEDESTRIAN RAILING	FOOT		1279	1279
NAME PLATES	EACH		1	1
PERMANENT CASING	FOOT	99		99
DRILLED SHAFT IN SOIL	CU YD	197		197
DRILLED SHAFT IN ROCK	CU YD	153		153
ANCHOR BOLTS, 1"	EACH	16		16
GEOCOMPOSITE WALL DRAIN	SQ YD	44		44
PIPE UNDERDRAINS 4"	FOOT	138		138
ELECTRIC UTILITY SERVICE CONNECTION	LSUM		1	1
SERVICE INSTALLATION, GROUND MOUNTED	EACH		2	2
UNDERGROUND CONDUIT, GALVANIZED STEEL, 1" DIA	FOOT		65	65
UNDERGROUND CONDUIT, GALVANIZED STEEL, 2" DIA	FOOT		570	570
UNDERGROUND CONDUIT, GALVANIZED STEEL, 4" DIA	FOOT		200	200
UNDERGROUND CONDUIT, PVC, 1" DIA	FOOT		275	275
UNDERGROUND CONDUIT, PVC, 2" DIA	FOOT		525	525
UNDERGROUND CONDUIT, PVC, 4" DIA	FOOT		280	280
CONDUIT EMBEDDED IN STRUCTURE, 1" DIA, PVC	FOOT		520	520
CONDUIT EMBEDDED IN STRUCTURE, 2" DIA, PVC	FOOT		2700	2700
CONDUIT EMBEDDED IN STRUCTURE, 4" DIA, PVC	FOOT		3520	3520
JUNCTION BOX EMBEDDED IN STRUCTURE, 18"x6"x6"	EACH		26	26
HANDHOLE	EACH		5	5
GULFBOX JUNCTION	EACH		2	2
ELECTRIC CABLE IN CONDUIT, 600V, (XLP-TYPE USE) 1/C NO. 10	FOOT		975	975
ELECTRIC CABLE IN CONDUIT, 600V, (XLP-TYPE USE) 1/C NO. 8	FOOT		5850	5850
ELECTRIC CABLE IN CONDUIT, 600V, (XLP-TYPE USE) 1/C NO. 6	FOOT		215	215
ELECTRIC CABLE IN CONDUIT, 600V, (XLP-TYPE USE) 1/C NO. 3	FOOT		430	430
LIGHTING CONTROLLER, BASE MOUNTED, 240V, 200AMP	EACH		2	2
CROSSHOLE SONIC LOGGING ACCESS TUBE	FOOT	305		305
CROSSHOLE SONIC LOGGING TESTING	EACH	3		3
ANTI GRAFFITI PROTECTION SYSTEM	SQ FT	264		264
PEDESTRIAN BRIDGE LIGHTING SYSTEM	LSUM		1	1
PEDESTRIAN RAIL (SPECIAL)	FOOT		276	276
HIGH LOAD MULTI-ROTATIONAL BEARINGS, GUIDED EXPANSION, 300K	EACH	4		4
JUNCTION BOX EMBEDDED IN STRUCTURE, (SPECIAL)	EACH		7	7
LUMINAIRE, LED, HORIZONTAL MOUNT, (SPECIAL)	EACH		1	1
LIGHTING UNIT COMPLETE, (SPECIAL)	EACH		1	1
MODULAR EXPANSION JOINT 6"	FOOT		39	39
TEMPORARY ACCESS CAUSEWAY	LSUM	1		1
ANTI GRAFFITI COATING	SQ FT		25155	25155
TEMPORARY BRIDGE	LSUM	1		1
BRIDGE DECK WEARING SURFACE	SQ YD		1541	1541

**ABBREVIATIONS**

Abut.	Abutment	Mat'l.	Material
Alt.	Alternate	Max.	Maximum
Const.	Construction	Min.	Minimum
Cts.	Centers	No.	Number
BB	Begin Bridge	Pc	Piece
Brg.	Bearing	P.G.	Proposed Grade
Btm.	Bottom	P.JF	Preformed Joint Filler
CL	Centerline	PL	Plate
Conc.	Concrete	PCC	Point of Compound Curvature
Dia	Diameter	PRC	Point of Reversing Curvature
(E)	Epoxy Coated	Prop.	Proposed
Ea	Each	R	Radius
EB	End Bridge	Rt.	Right
EF	Each Face	Sim.	Similar
EJF	Expansion Joint Filler	Spa.	Spacing
Elev.	Elevation	Spcs.	Spaces
Est.	Estimated	Sta.	Station
Exist.	Existing	TBD	To Be Determined
Exp.	Expansion	TOB	Top of Box
Jt.	Joint	Tot.	Total
HLMR	High Load Multi Rotational	Typ.	Typical
Horiz.	Horizontal	(V)	Varies
EOD	Edge of Deck	Var.	Varies
Lt.	Left	Vert.	Vertical
		WP	Work Point

STATION 101+28.75  
BUILT 20-- BY  
CITY OF AURORA  
LOADING H-10  
STR. NO. 045-P008

**NAME PLATE**  
See Std. 515001

FILE NAME = 045P008-XXXX-002-GENDATA1.dgn

	USER NAME = RSTONE	DESIGNED - B. Sokolowski	REVISED - -	<b>STATE OF ILLINOIS</b> <b>DEPARTMENT OF TRANSPORTATION</b>	<b>GENERAL DATA 1</b> <b>STRUCTURE NO. 045-P008</b>	F.A.U. RT.E.	SECTION	COUNTY	TOTAL SHEETS	SHEET NO.
	CHECKED - P. Frey	REVISIED - -	2503			16-00313-00-MS	KANE	254	163	
PLOT SCALE = NO SCALE	DRAWN - I. Martin	REVISED - -				CONTRACT NO.		61E18		
PLOT DATE = 10/19/2017	CHECKED - D. Fitzwilliam	REVISED - -				ILLINOIS FED. AID PROJECT				

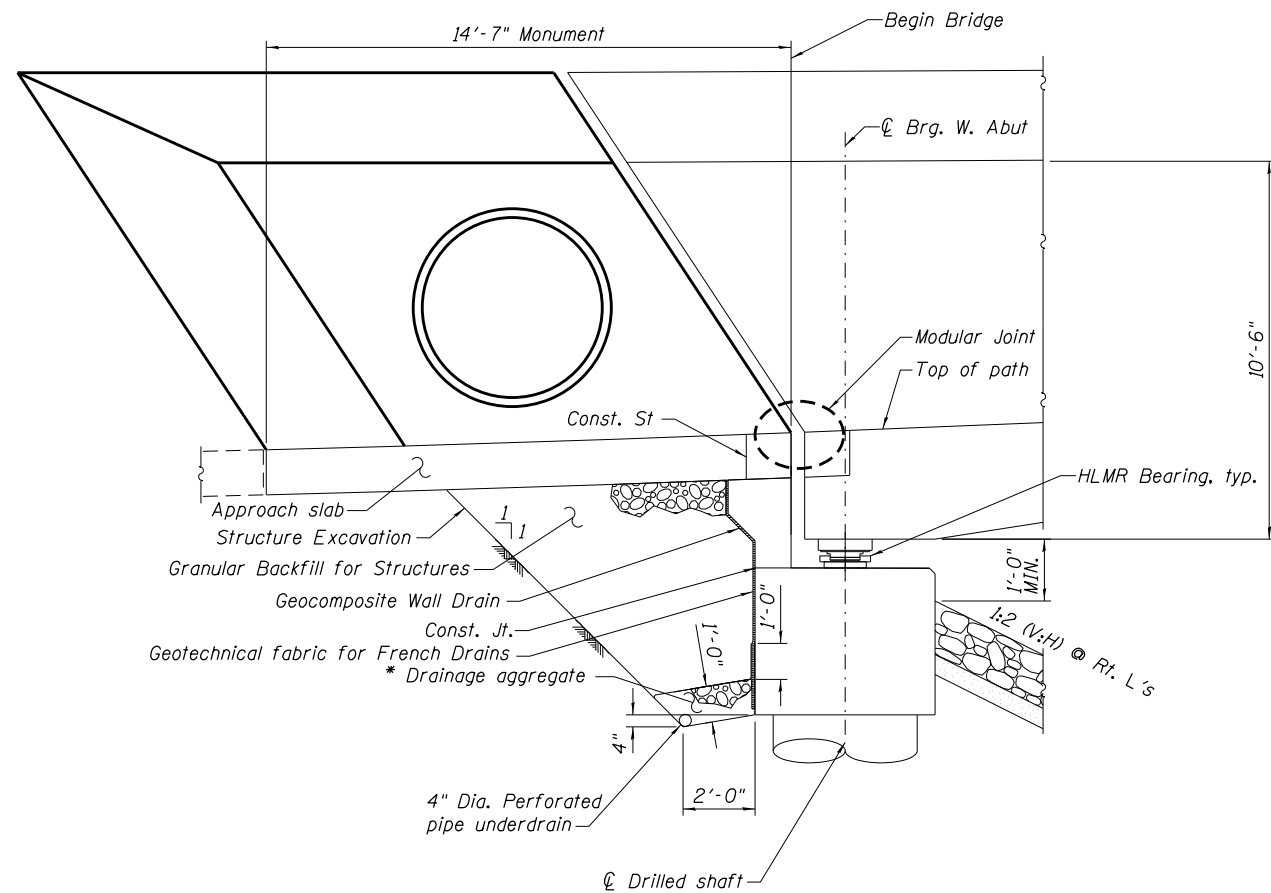

Notes:  
 \* Included in the cost of pipe under drain for structures.  
 All drainage system components shall extend 2'-0" from the end of each wingwall with the exception of the drainage pipe which shall extend until it intersects with the side slopes.  
 The pipes shall drain into the slope protection.

**SECTION THROUGH WEST ABUTMENT**

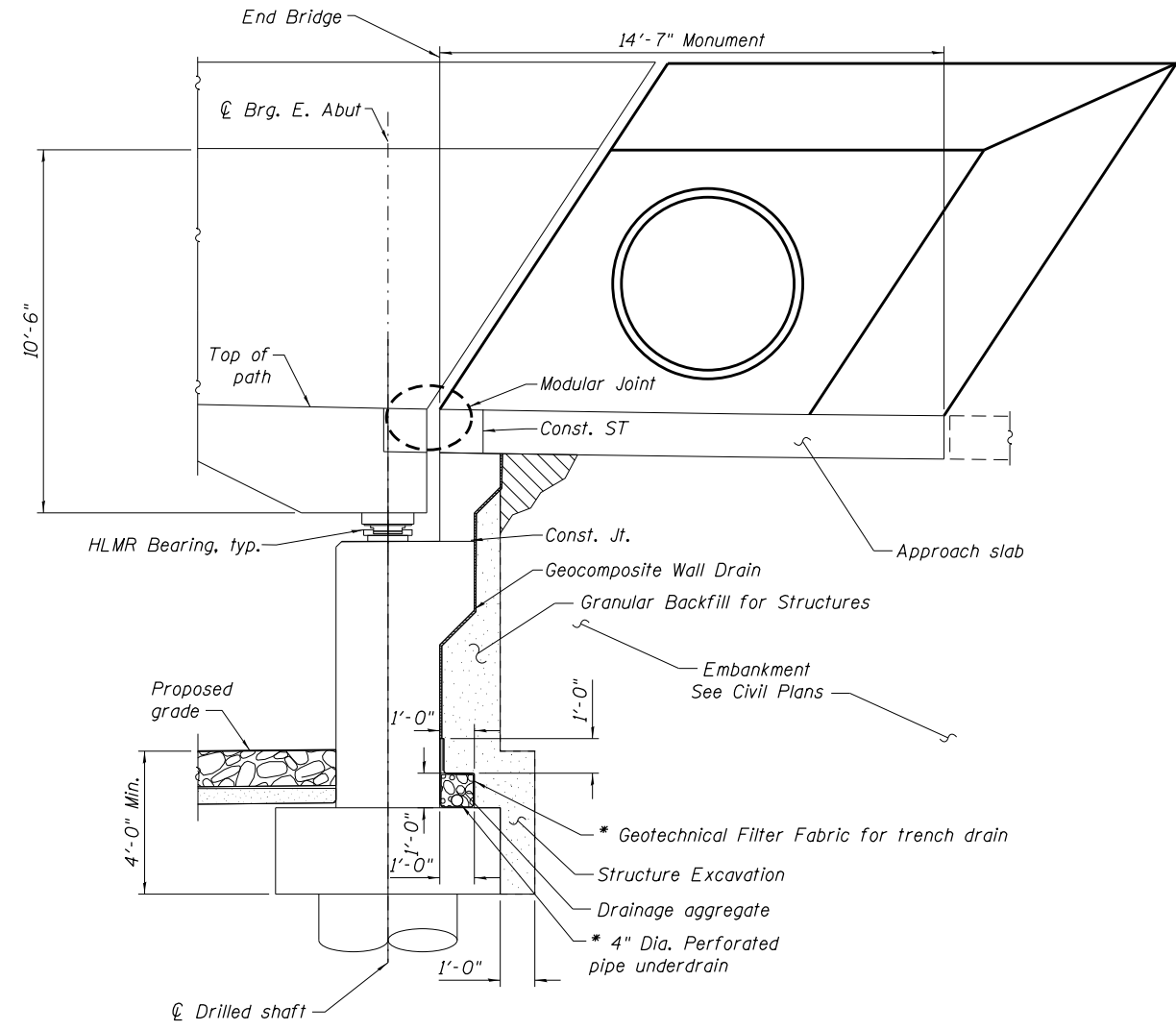

**SECTION THROUGH EAST ABUTMENT**

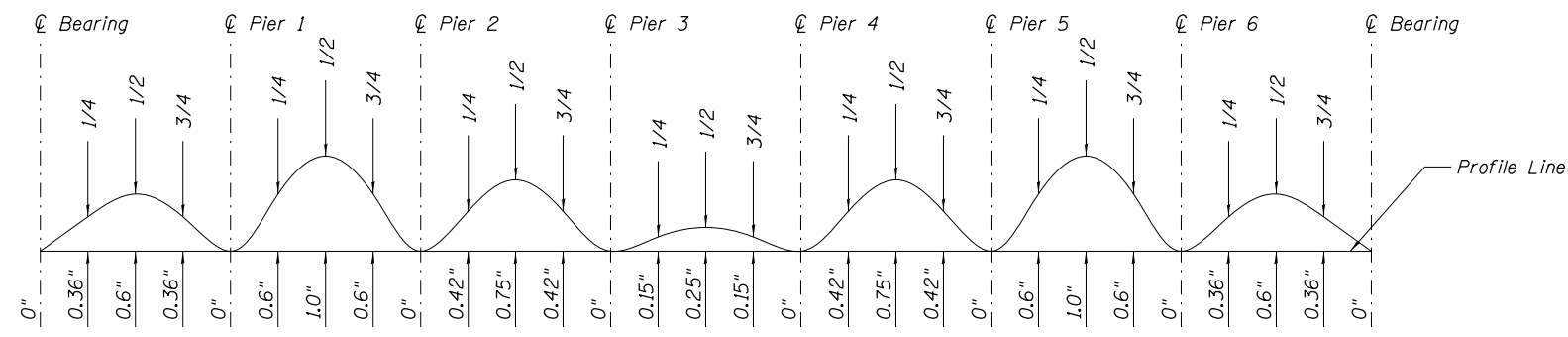

**CAMBER DIAGRAM**  
No Scale

**NOTE:**  
 1. Camber diagram does not include allowance for falsework settlement.

FILE NAME = 045P008-XXXX-003-GENDATA2.dgn

<b>TY-LIN INTERNATIONAL</b>	USER NAME = RSTONE	DESIGNED - B. Sokolowski	REVISED - -	<b>STATE OF ILLINOIS</b> <b>DEPARTMENT OF TRANSPORTATION</b>	<b>GENERAL DATA 2</b> <b>STRUCTURE NO. 045-P008</b>	F.A.U. RTE.	SECTION	COUNTY	TOTAL SHEETS	SHEET NO.
	PLOT SCALE = NO SCALE	CHECKED - P. Frey	REVISED - -			2503	16-00313-00-MS	KANE	254	164
	PLOT DATE = 10/19/2017	DRAWN - I. Martin	REVISED - -			CONTRACT NO.		61E18		
		CHECKED - D. Fitzwilliam	REVISED - -			ILLINOIS FED. AID PROJECT				



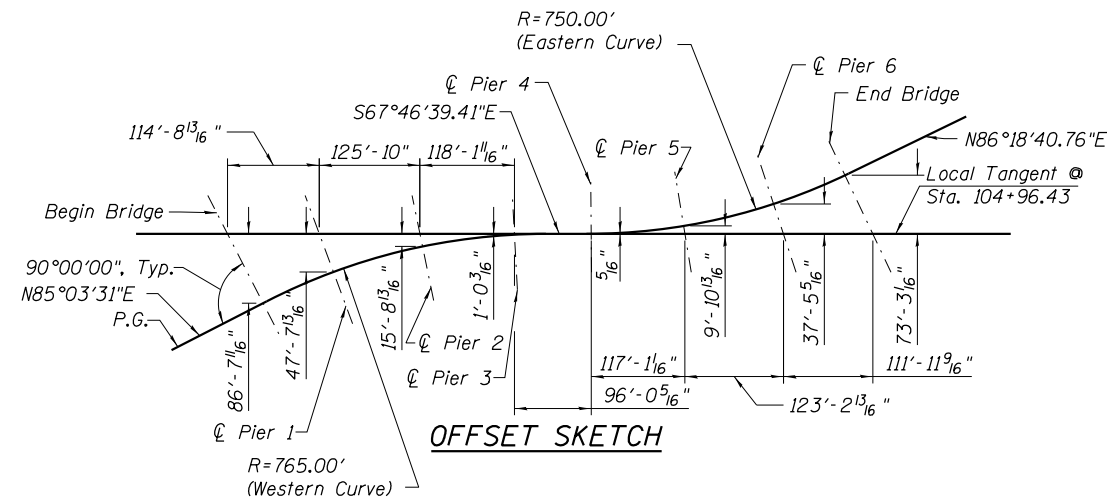

CURVE DATA		CURVE DATA	
(Western Curve)		(Eastern Curve)	
P.I. Sta. = 103+18.56	$\Delta = 27^\circ 09' 50"$	P.I. Sta. = 107+19.54	$\Delta = 25^\circ 54' 40"$
$D = 7^\circ 29' 23"$	$R = 765.00'$	$D = 7^\circ 38' 22"$	$R = 750.00'$
$T = 184.82'$	$L = 362.68'$	$T = 172.54'$	$L = 339.18'$
$E = 22.01'$	$T.R. = NA$	$E = 19.59'$	$T.R. = NA$
S.E. Run = NA		S.E. Run = NA	
P.C. Sta. = 101+33.74		P.C. Sta. = 105+47.00	
P.T. Sta. = 104+96.43		P.T. Sta. = 108+86.18	

**CURVE DATA TABLE**

Curve	R	$\Delta$	T	L
(A)	270.79	$6^\circ 54' 37.62"$	16.35	32.66
(B)	94.02	$19^\circ 38' 27.46"$	16.27	32.23
(C)	180.00	$10^\circ 14' 12.65"$	16.12	32.16
(D)	150.00	$12^\circ 11' 5.65"$	16.01	31.90
(E)	96.84	$18^\circ 27' 34.59"$	15.74	31.20
(F)	214.50	$8^\circ 46' 19.19"$	16.45	32.84

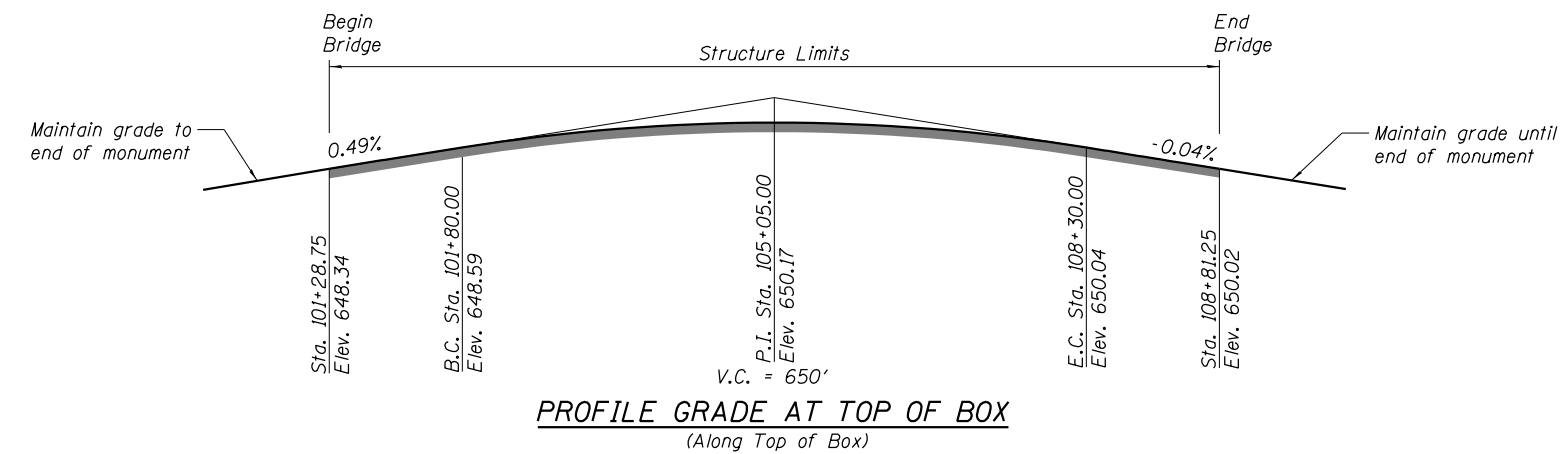
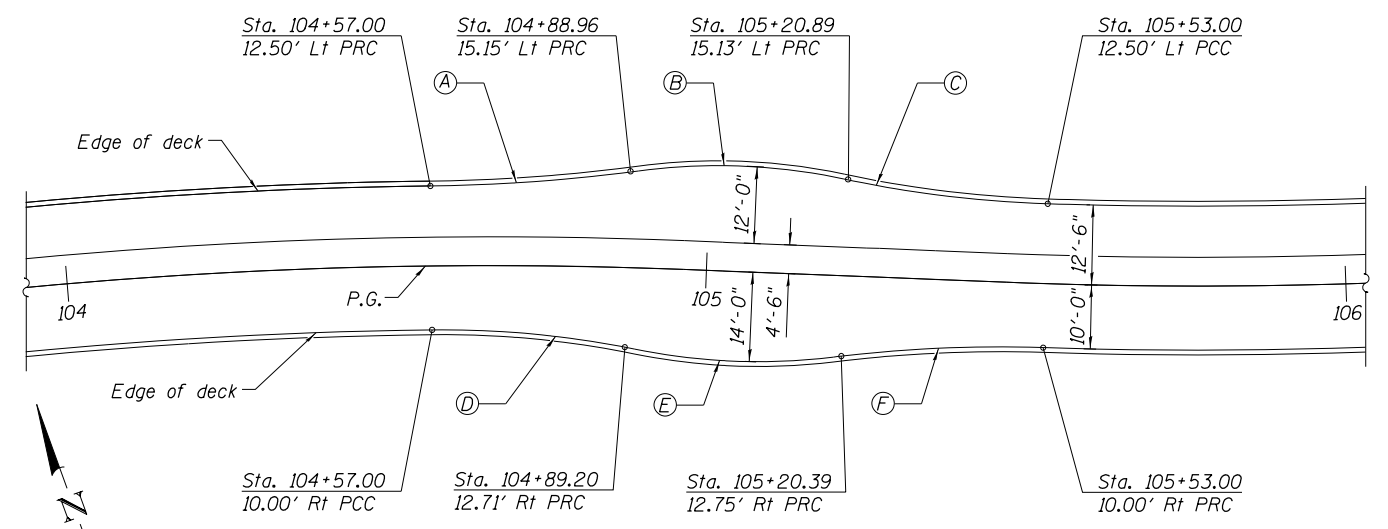
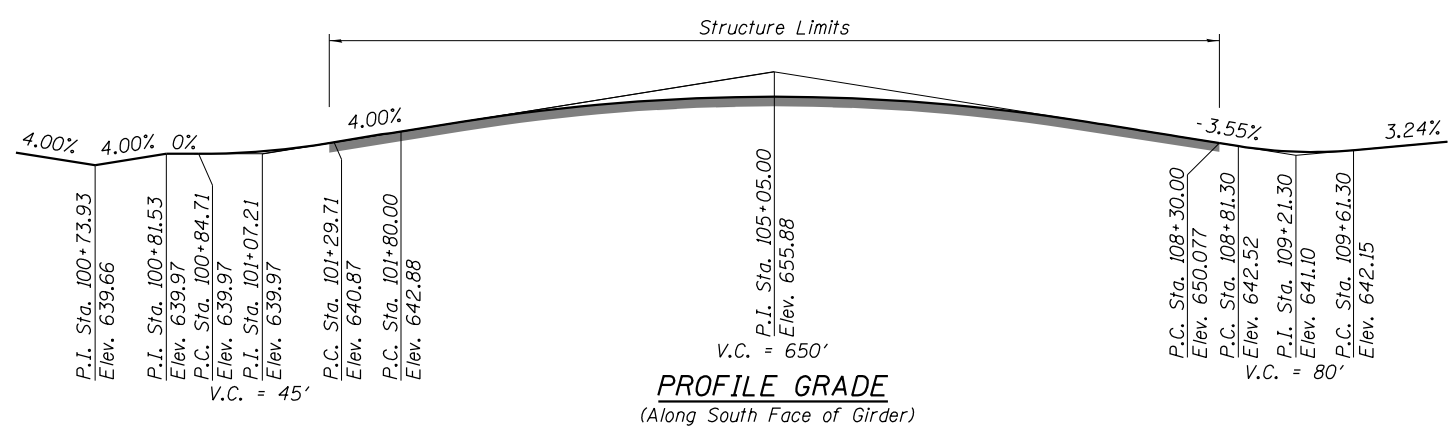

FILE NAME = 045P008-XXXX-004-GEOMDATA.dgn



USER NAME = RSTONE	DESIGNED - B. Sokolowski	REVISED - -
PLOT SCALE = NO SCALE	CHECKED - P. Frey	REVISED - -
PLOT DATE = 10/19/2017	DRAWN - I. Martin	REVISED - -
	CHECKED - D. Fitzwilliam	REVISED - -

**STATE OF ILLINOIS**  
**DEPARTMENT OF TRANSPORTATION**

**GEOMETRY DATA**  
**STRUCTURE NO. 045-P008**

F.A.U. RTE.	SECTION	COUNTY	TOTAL SHEETS	SHEET NO.
2503	16-00313-00-MS	KANE	254	165
CONTRACT NO.			61E18	

SHEET NO. 5-4 OF 5-69 SHEETS

ILLINOIS FED. AID PROJECT

**DECK GRADES**

Location	Station	P.G. Elev	P.G. TOB Elev	Rt. EOD Elev	Lt. EOD Elev
BB	101+28.75	640.84	648.34	640.74	640.76
Span 1	101+30.00	640.88	648.35	640.78	640.80
Span 1	101+35.00	641.08	648.37	640.98	641.00
Span 1	101+40.00	641.28	648.40	641.18	641.20
Span 1	101+45.00	641.48	648.42	641.38	641.40
Span 1	101+50.00	641.68	648.44	641.58	641.60
Span 1	101+55.00	641.88	648.47	641.78	641.80
Span 1	101+60.00	642.08	648.49	641.98	642.00
Span 1	101+65.00	642.28	648.52	642.18	642.20
Span 1	101+70.00	642.48	648.54	642.38	642.40
Span 1	101+75.00	642.68	648.57	642.58	642.60
Span 1	101+80.00	642.88	648.59	642.78	642.80
Span 1	101+85.00	643.08	648.61	642.98	643.00
Span 1	101+90.00	643.27	648.64	643.17	643.19
Span 1	101+95.00	643.47	648.66	643.37	643.39
Span 1	102+00.00	643.66	648.69	643.56	643.58
Span 1	102+05.00	643.84	648.71	643.74	643.76
Span 1	102+10.00	644.03	648.73	643.93	643.95
Span 1	102+15.00	644.21	648.76	644.11	644.13
Span 1	102+20.00	644.39	648.78	644.29	644.31
☉ Pier 1	102+25.00	644.56	648.80	644.46	644.48
Span 2	102+30.00	644.73	648.82	644.63	644.65
Span 2	102+35.00	644.90	648.85	644.80	644.82
Span 2	102+40.00	645.07	648.87	644.97	644.99
Span 2	102+45.00	645.23	648.89	645.13	645.15
Span 2	102+50.00	645.40	648.91	645.30	645.32
Span 2	102+55.00	645.55	648.93	645.45	645.47
Span 2	102+60.00	645.71	648.96	645.61	645.63
Span 2	102+65.00	645.86	648.98	645.76	645.78
Span 2	102+70.00	646.01	649.00	645.91	645.93
Span 2	102+75.00	646.16	649.02	646.06	646.08
Span 2	102+80.00	646.30	649.04	646.20	646.22
Span 2	102+85.00	646.44	649.06	646.34	646.36
Span 2	102+90.00	646.58	649.08	646.48	646.50
Span 2	102+95.00	646.71	649.10	646.61	646.63
Span 2	103+00.00	646.84	649.12	646.74	646.76
Span 2	103+05.00	646.97	649.14	646.87	646.89
Span 2	103+10.00	647.10	649.16	647.00	647.02
Span 2	103+15.00	647.22	649.18	647.12	647.14
Span 2	103+20.00	647.34	649.20	647.24	647.26
Span 2	103+25.00	647.46	649.21	647.36	647.38
Span 2	103+30.00	647.57	649.23	647.47	647.49
Span 2	103+35.00	647.68	649.25	647.58	647.60
Span 2	103+40.00	647.79	649.27	647.69	647.71
☉ Pier 2	103+41.00	647.81	649.27	647.71	647.73
Span 3	103+45.00	647.90	649.29	647.80	647.82
Span 3	103+50.00	648.00	649.31	647.90	647.92
Span 3	103+55.00	648.10	649.32	648.00	648.02
Span 3	103+60.00	648.20	649.34	648.10	648.12
Span 3	103+65.00	648.29	649.36	648.19	648.21
Span 3	103+70.00	648.38	649.37	648.28	648.30
Span 3	103+75.00	648.47	649.39	648.37	648.39
Span 3	103+80.00	648.56	649.41	648.46	648.48
Span 3	103+85.00	648.64	649.42	648.54	648.56
Span 3	103+90.00	648.72	649.44	648.62	648.64
Span 3	103+95.00	648.80	649.46	648.70	648.72
Span 3	104+00.00	648.87	649.47	648.77	648.79
Span 3	104+05.00	648.94	649.49	648.84	648.86
Span 3	104+10.00	649.01	649.50	648.91	648.93
Span 3	104+15.00	649.07	649.52	648.97	648.99
Span 3	104+20.00	649.13	649.53	649.03	649.05
Span 3	104+25.00	649.19	649.55	649.09	649.11
Span 3	104+30.00	649.25	649.56	649.15	649.17
Span 3	104+35.00	649.30	649.57	649.20	649.22
Span 3	104+40.00	649.35	649.59	649.25	649.27
Span 3	104+45.00	649.40	649.60	649.30	649.32
Span 3	104+50.00	649.45	649.62	649.35	649.37
Span 3	104+55.00	649.49	649.63	649.39	649.41

**DECK GRADES**

Location	Station	P.G. Elev	P.G. TOB Elev	Rt. EOD Elev	Lt. EOD Elev
☉ Pier 3	104+57.00	649.50	649.63	649.40	649.42
Span 4	104+60.00	649.53	649.64	649.43	649.45
Span 4	104+65.00	649.56	649.66	649.46	649.48
Span 4	104+70.00	649.60	649.67	649.49	649.51
Span 4	104+75.00	649.63	649.68	649.52	649.54
Span 4	104+80.00	649.65	649.69	649.54	649.56
Span 4	104+85.00	649.68	649.71	649.56	649.58
Span 4	104+90.00	649.70	649.72	649.57	649.59
Span 4	104+95.00	649.72	649.73	649.58	649.60
Span 4	105+00.00	649.73	649.74	649.59	649.61
Mid Bridge	105+05.00	649.75	649.75	649.61	649.63
Span 4	105+10.00	649.76	649.76	649.62	649.64
Span 4	105+15.00	649.76	649.77	649.63	649.65
Span 4	105+20.00	649.77	649.78	649.64	649.66
Span 4	105+25.00	649.77	649.80	649.65	649.67
Span 4	105+30.00	649.77	649.81	649.65	649.67
Span 4	105+35.00	649.76	649.82	649.65	649.67
Span 4	105+40.00	649.75	649.83	649.65	649.67
Span 4	105+45.00	649.74	649.84	649.64	649.66
Span 4	105+50.00	649.73	649.84	649.63	649.65
☉ Pier 4	105+53.00	649.72	649.85	649.62	649.64
Span 5	105+55.00	649.71	649.85	649.61	649.63
Span 5	105+60.00	649.69	649.86	649.59	649.61
Span 5	105+65.00	649.67	649.87	649.57	649.59
Span 5	105+70.00	649.65	649.88	649.55	649.57
Span 5	105+75.00	649.62	649.89	649.52	649.54
Span 5	105+80.00	649.59	649.90	649.49	649.51
Span 5	105+85.00	649.55	649.91	649.45	649.47
Span 5	105+90.00	649.52	649.91	649.42	649.44
Span 5	105+95.00	649.48	649.92	649.38	649.40
Span 5	106+00.00	649.44	649.93	649.34	649.36
Span 5	106+05.00	649.39	649.94	649.29	649.31
Span 5	106+10.00	649.34	649.94	649.24	649.26
Span 5	106+15.00	649.29	649.95	649.19	649.21
Span 5	106+20.00	649.24	649.96	649.14	649.16
Span 5	106+25.00	649.18	649.96	649.08	649.10
Span 5	106+30.00	649.12	649.97	649.02	649.04
Span 5	106+35.00	649.06	649.98	648.96	648.98
Span 5	106+40.00	648.99	649.98	648.89	648.91
Span 5	106+45.00	648.92	649.99	648.82	648.84
Span 5	106+50.00	648.85	649.99	648.75	648.77
Span 5	106+55.00	648.78	650.00	648.68	648.70
Span 5	106+60.00	648.70	650.00	648.60	648.62
Span 5	106+65.00	648.62	650.01	648.52	648.54

**DECK GRADES**

Location	Station	P.G. Elev	P.G. TOB Elev	Rt. EOD Elev	Lt. EOD Elev
☉ Pier 5	106+69.00	648.55	650.01	648.45	648.47
Span 6	106+70.00	648.54	650.01	648.44	648.46
Span 6	106+75.00	648.45	650.02	648.35	648.37
Span 6	106+80.00	648.36	650.02	648.26	648.28
Span 6	106+85.00	648.27	650.02	648.17	648.19
Span 6	106+90.00	648.17	650.03	648.07	648.09
Span 6	106+95.00	648.08	650.03	647.98	648.00
Span 6	107+00.00	647.98	650.04	647.88	647.90
Span 6	107+05.00	647.87	650.04	647.77	647.79
Span 6	107+10.00	647.77	650.04	647.67	647.69
Span 6	107+15.00	647.66	650.04	647.56	647.58
Span 6	107+20.00	647.54	650.05	647.44	647.46
Span 6	107+25.00	647.43	650.05	647.33	647.35
Span 6	107+30.00	647.31	650.05	647.21	647.23
Span 6	107+35.00	647.19	650.05	647.09	647.11
Span 6	107+40.00	647.07	650.06	646.97	646.99
Span 6	107+45.00	646.94	650.06	646.84	646.86
Span 6	107+50.00	646.81	650.06	646.71	646.73
Span 6	107+55.00	646.68	650.06	646.58	646.60
Span 6	107+60.00	646.54	650.06	646.44	646.46
Span 6	107+65.00	646.40	650.06	646.30	646.32
Span 6	107+70.00	646.26	650.06	646.16	646.18
Span 6	107+75.00	646.12	650.06	646.02	646.04
Span 6	107+80.00	645.97	650.06	645.87	645.89
☉ Pier 6	107+85.00	645.82	650.06	645.72	645.74
Span 7	107+90.00	645.67	650.06	645.57	645.59
Span 7	107+95.00	645.51	650.06	645.41	645.43
Span 7	108+00.00	645.36	650.06	645.26	645.28
Span 7	108+05.00	645.19	650.06	645.09	645.11
Span 7	108+10.00	645.03	650.06	644.93	644.95
Span 7	108+15.00	644.86	650.06	644.76	644.78
Span 7	108+20.00	644.69	650.06	644.59	644.61
Span 7	108+25.00	644.52	650.05	644.42	644.44
Span 7	108+30.00	644.34	650.04	644.24	644.26
Span 7	108+35.00	644.16	650.04	644.06	644.08
Span 7	108+40.00	643.99	650.04	643.89	643.91
Span 7	108+45.00	643.81	650.03	643.71	643.73
Span 7	108+50.00	643.63	650.03	643.53	643.55
Span 7	108+55.00	643.45	650.03	643.35	643.37
Span 7	108+60.00	643.28	650.03	643.18	643.20
Span 7	108+65.00	643.10	650.03	643.00	643.02
Span 7	108+70.00	642.92	650.02	642.82	642.84
Span 7	108+75.00	642.74	650.02	642.64	642.66
Span 7	108+80.00	642.57	650.02	642.47	642.49
EB	108+81.25	642.52	650.02	642.42	642.44

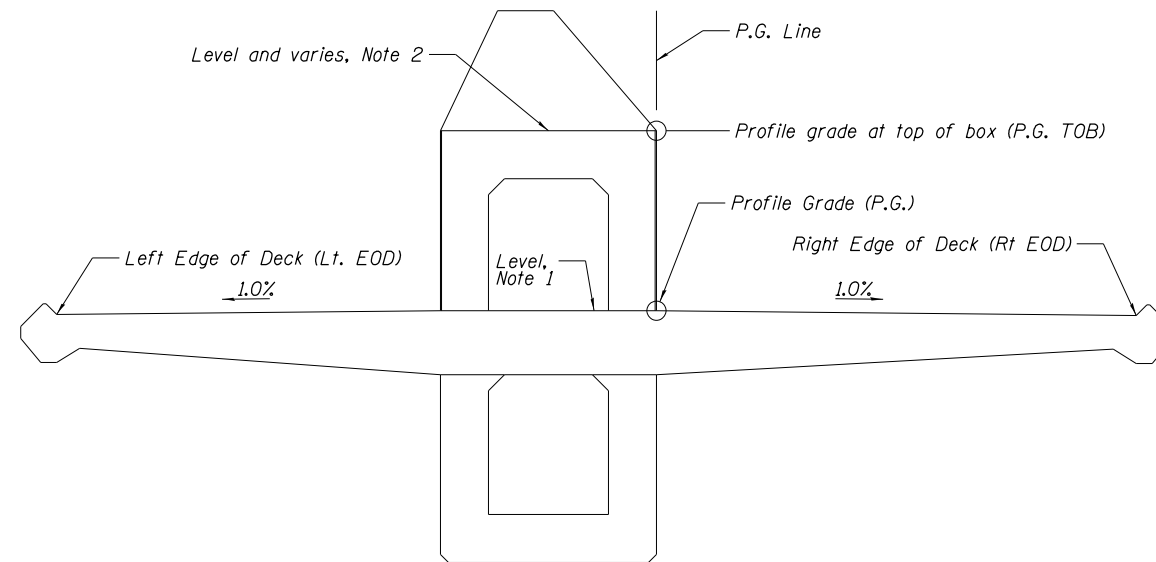

- NOTES:  
 1. Deck is level from P.G. to outside face of opposite girder.  
 2. Top of box is level except in Span 4.  
 See "BENCH DETAILS" sheet

**TYPICAL SECTION**  
Looking Upstation

FILE NAME = 045P008-XXXX-005-DECKCONTOURS.dgn



USER NAME = RSTONE	DESIGNED - B. Sokolowski	REVISED - -
	CHECKED - P. Frey	REVISED - -
PLOT SCALE = NO SCALE	DRAWN - I. Martin	REVISED - -
PLOT DATE = 10/19/2017	CHECKED - D. Fitzwilliam	REVISED - -

**STATE OF ILLINOIS**  
**DEPARTMENT OF TRANSPORTATION**

**DECK CONTOURS**<

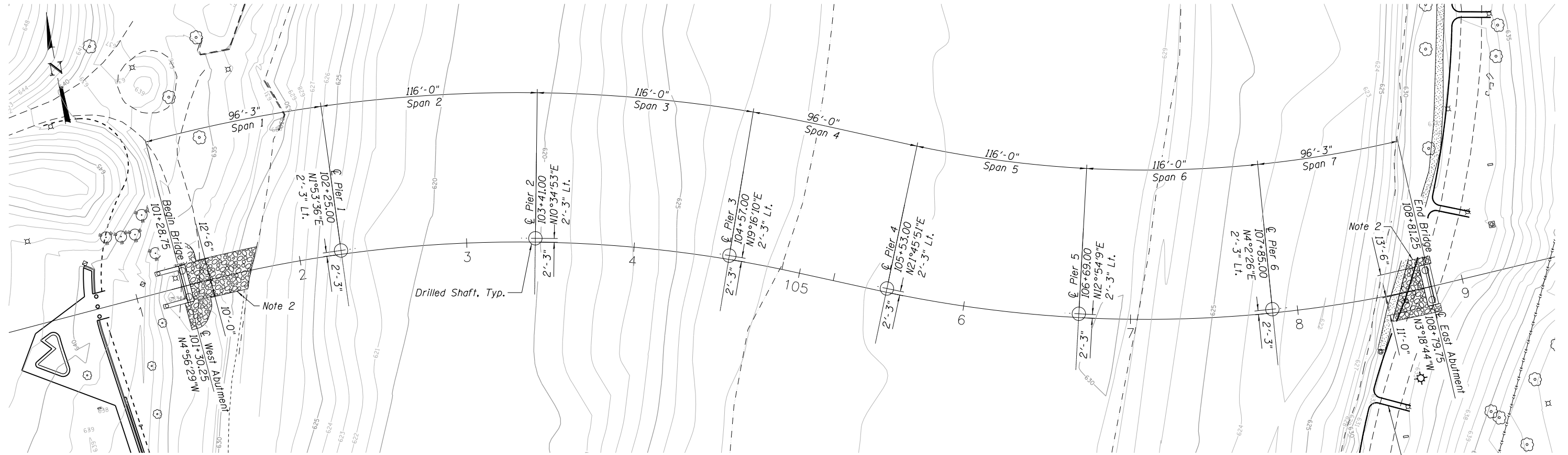

**FOOTING LAYOUT**

Existing electrical conduit

- NOTE:**
1. For drilled shaft dimensions see, "PIER DETAILS 1-6" sheets.
  2. For Riprap details see "LANDSCAPE PLANS"

FILE NAME = 045P008-XXXXX-006-FTGLAYOUT.dgn



USER NAME = RSTONE	DESIGNED - B. Sokolowski	REVISED - -
PLOT SCALE = NO SCALE	CHECKED - P. Frey	REVISED - -
PLOT DATE = 10/19/2017	DRAWN - O. Colcol	REVISED - -
	CHECKED - D. Fitzwilliam	REVISED - -

**STATE OF ILLINOIS  
DEPARTMENT OF TRANSPORTATION**

**FOOTING LAYOUT  
STRUCTURE NO. 045-P008**

SHEET NO. S-6 OF S-69 SHEETS

F.A.U. RT.E.	SECTION	COUNTY	TOTAL SHEETS	SHEET NO.
2503	16-00313-00-MS	KANE	254	167
CONTRACT NO.			61E18	

ILLINOIS FED. AID PROJECT

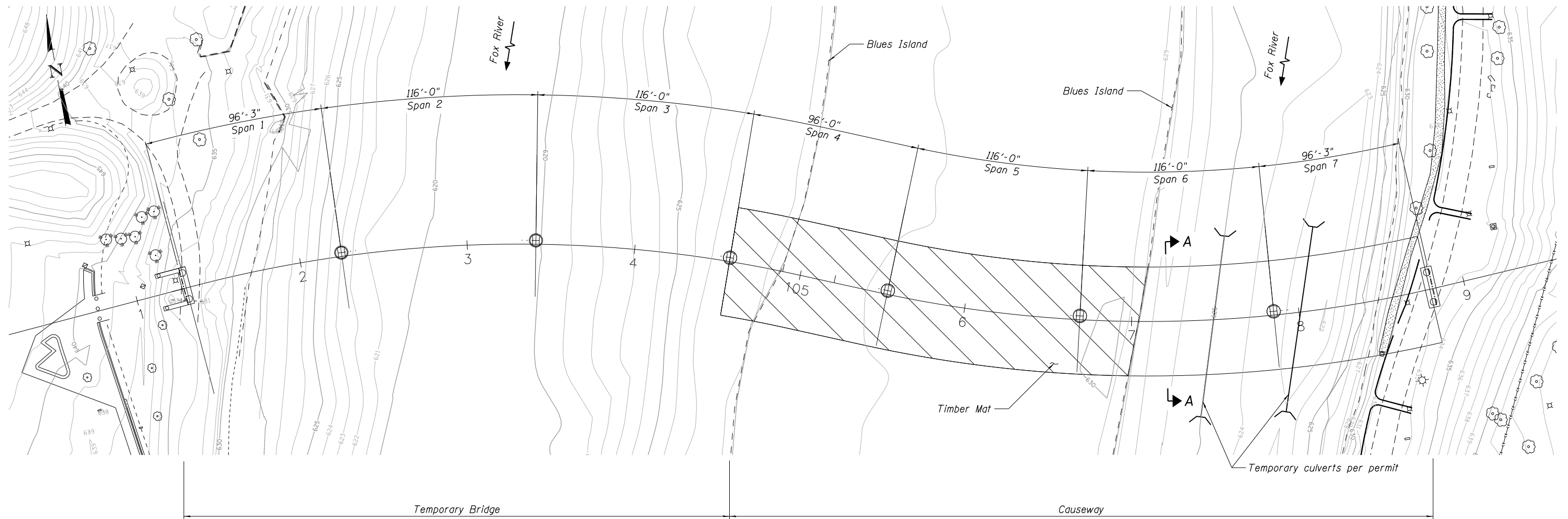

**CAUSEWAY LAYOUT**

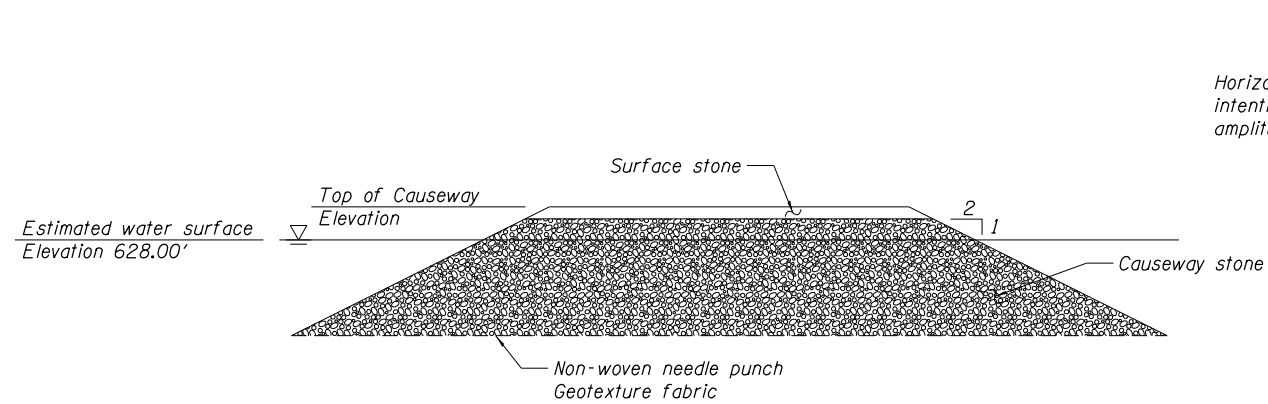

**SECTION A-A**  
Review permit for causeway requirements.

Horizontal Construction Joints shall be intentionally roughened to 1/4" amplitude.

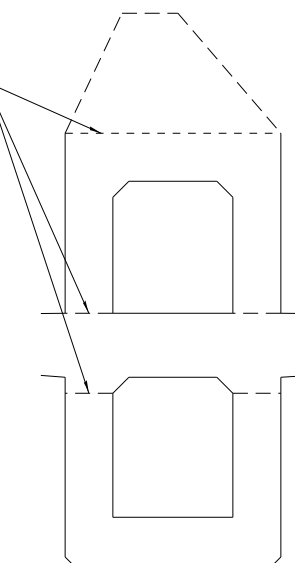

**HORIZONTAL JOINTS**

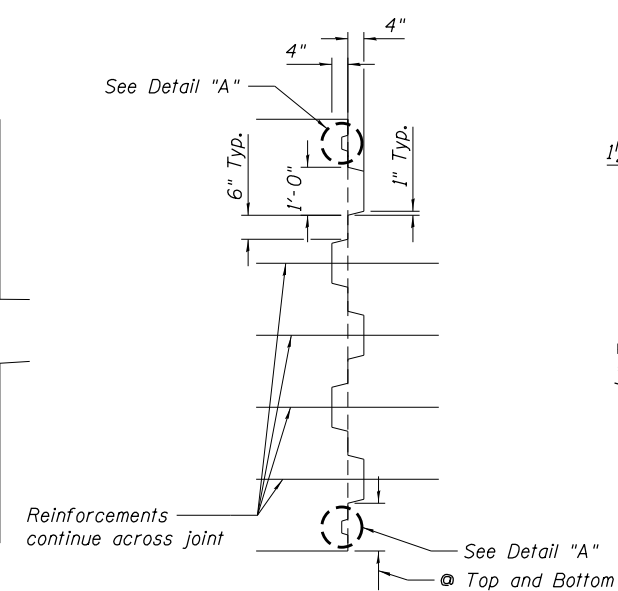

**LONGITUDINAL JOINTS**

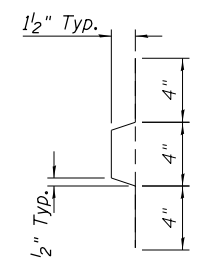

**DETAIL A**

**CONSTRUCTION JOINT DETAILS**

FILE NAME = 045P008-XXXX-007-TMPACASWY.dgn

**TY-LIN INTERNATIONAL**

USER NAME = RSTONE	DESIGNED - B. Sokolowski	REVISED - -
	CHECKED - P. Frey	REVISED - -
PLOT SCALE = NO SCALE	DRAWN - I. Martin	REVISED - -
PLOT DATE = 10/19/2017	CHECKED - D. Fitzwilliam	REVISED - -

**STATE OF ILLINOIS  
DEPARTMENT OF TRANSPORTATION**

**TEMPORARY ACCESS CAUSEWAY  
STRUCTURE NO. 045-P008**

SHEET NO. 5-7 OF 5-69 SHEETS

F.A.U. RTE.	SECTION	COUNTY	TOTAL SHEETS	SHEET NO.
2503	16-00313-00-MS	KANE	254	168
CONTRACT NO.			61E18	

ILLINOIS FED. AID PROJECT

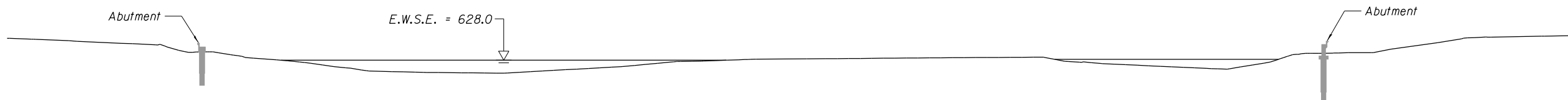

**CONSTRUCTION SEQUENCE 1**  
 1.1 Construct East and West abutments.

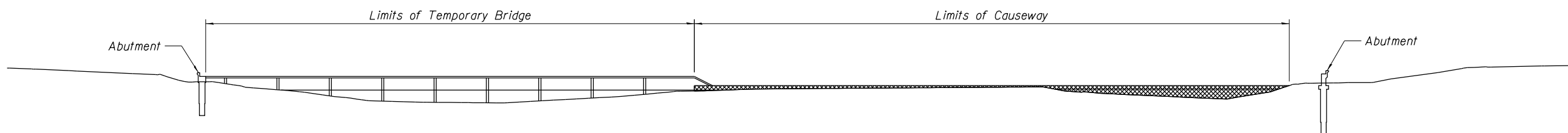

**CONSTRUCTION SEQUENCE 2**  
 2.1 Construct Causeway.  
 2.2 Construct temporary bridge.  
 Note: Check permit for restrictions on in water work.

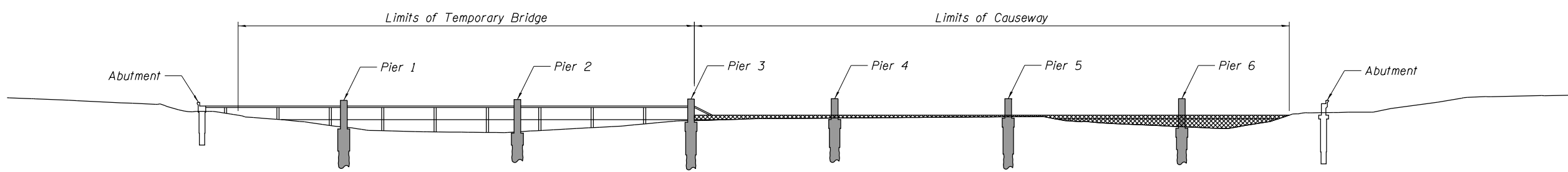

**CONSTRUCTION SEQUENCE 3**  
 3.1 Construct Piles  
 3.2 Construct Columns  
 Note: Check permit for restrictions on in water work.

- NOTES:
1. Recommended construction sequence. Alternatives shall be approved by the engineer.
  2. Temporary bridge shown is schematic.
  3. Horizontal temporary bridge elements shall be placed above 100-year flood elevation.

FILE NAME = 045P008-XXXX-008-CNST5E001.dgn

	USER NAME = RSTONE	DESIGNED - B. Sokolowski	REVISED - -	<b>STATE OF ILLINOIS</b> <b>DEPARTMENT OF TRANSPORTATION</b>	<b>RECOMMENDED CONSTRUCTION SEQUENCE 1</b> <b>STRUCTURE NO. 045-P008</b>	F.A.U. RTE.	SECTION	COUNTY	TOTAL SHEETS	SHEET NO.
	PLOT SCALE = NO SCALE	CHECKED - P. Frey	REVISED - -			2503	16-00313-00-MS	KANE	254	169
	PLOT DATE = 10/19/2017	DRAWN - I. Martin	REVISED - -			CONTRACT NO.		61E18		
	CHECKED - D. Fitzwilliam	REVISED - -		SHEET NO. 5-8 OF 5-69 SHEETS		ILLINOIS FED. AID PROJECT				

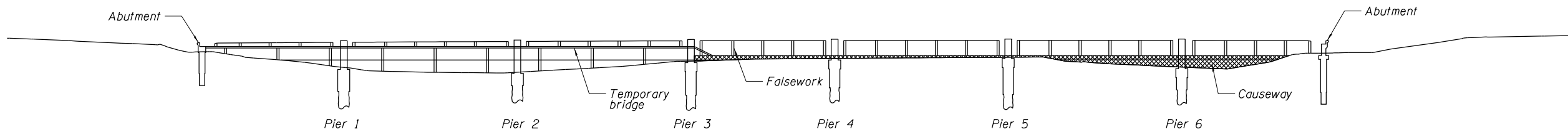

**CONSTRUCTION SEQUENCE 4**  
4.1 Construct falsework for superstructure.

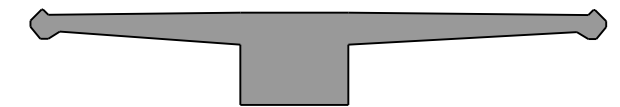

**SECTION A5-A5**

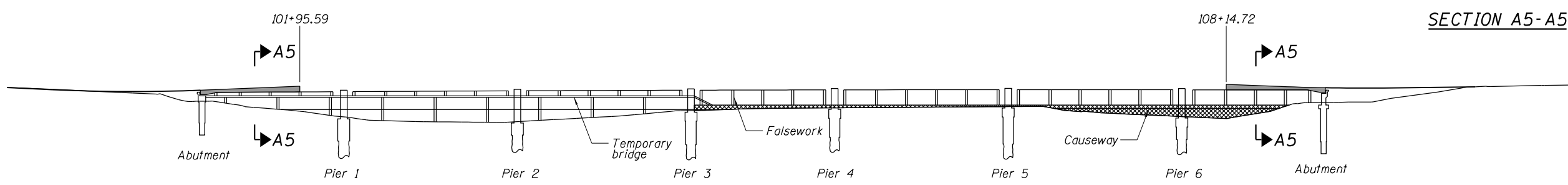

**CONSTRUCTION SEQUENCE 5**  
5.1 Pour concrete for end regions.  
5.2 Begin bridge lighting conduit installation.

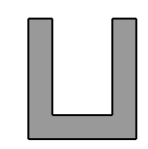

**SECTION B6-B6**

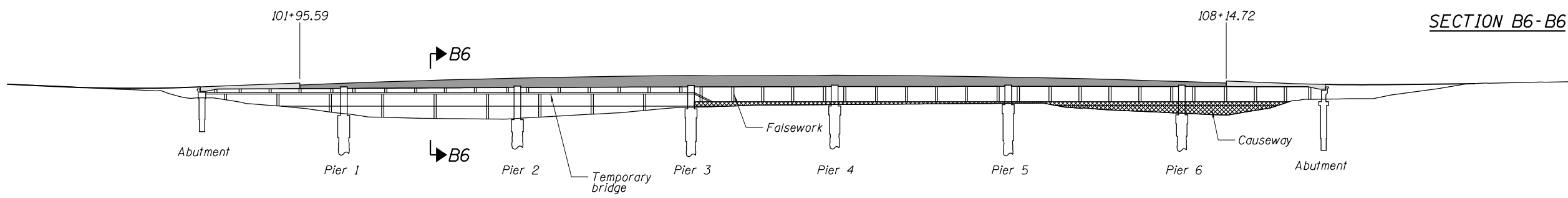

**CONSTRUCTION SEQUENCE 6**  
6.1 Pour concrete for lower portion of box.  
6.2 Begin installation of conduit for future utilities.

- NOTES:**
1. Recommended construction sequence. Alternatives shall be approved by the engineer.
  2. For future utilities details, see "FUTURE UTILITIES" sheet.
  3. For Bridge lighting conduit details see "BRIDGE LIGHTING DETAILS" sheet.
  4. Temporary bridge and falsework shown are schematic.
  5. Horizontal temporary bridge elements shall be placed above 100-year flood elevation.

FILE NAME = 045P008-XXXX-009-CNS15E002.dgn

	USER NAME = RSTONE	DESIGNED - B. Sokolowski	REVISED - -	<b>STATE OF ILLINOIS</b> <b>DEPARTMENT OF TRANSPORTATION</b>	<b>RECOMMENDED CONSTRUCTION SEQUENCE 2</b> <b>STRUCTURE NO. 045-P008</b>	F.A.U. RTE.	SECTION	COUNTY	TOTAL SHEETS	SHEET NO.
	PLOT SCALE = NO SCALE	CHECKED - P. Frey	REVISED - -			2503	16-00313-00-MS	KANE	254	170
	PLOT DATE = 10/19/2017	DRAWN - I. Martin	REVISED - -			CONTRACT NO.		61E18		
	CHECKED - D. Fitzwilliam	REVISED - -				ILLINOIS FED. AID PROJECT				

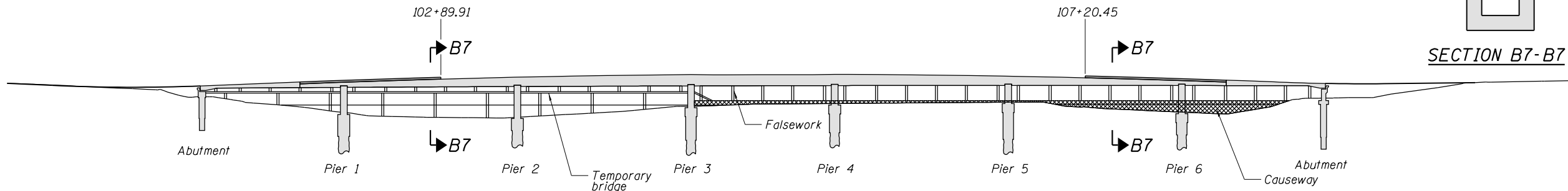
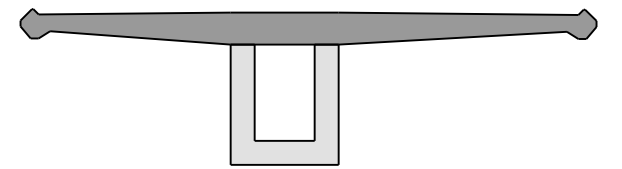

**CONSTRUCTION SEQUENCE 7**  
 7.1 Pour partial deck.  
 7.2 Continue future utility conduit installation.  
 7.3 Continue bridge lighting conduit installation

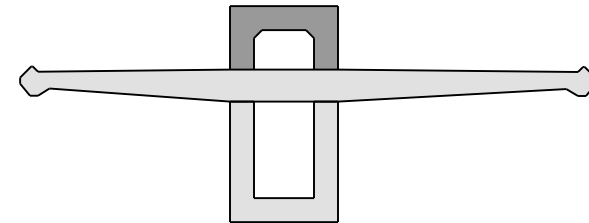
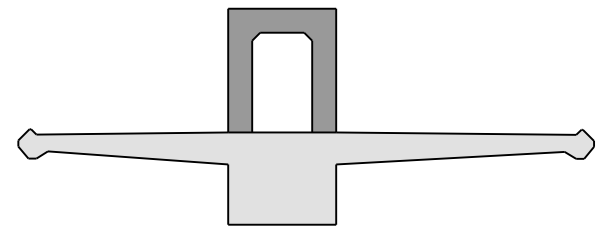

**SECTION A8-A8**

**SECTION B8-B8**

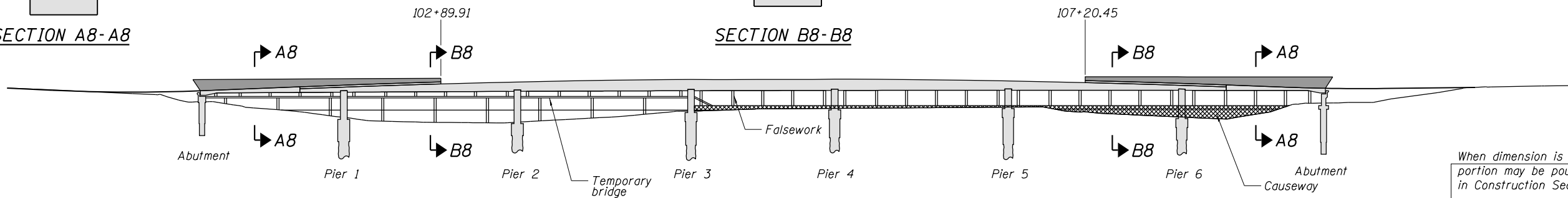

**CONSTRUCTION SEQUENCE 8**  
 8.1 Pour above deck at end regions.  
 8.2 Complete future utility conduit installation.  
 8.3 Continue bridge lighting conduit installation

When dimension is less than 3 1/2"  
 portion may be poured with cornice  
 in Construction Sequence 11.

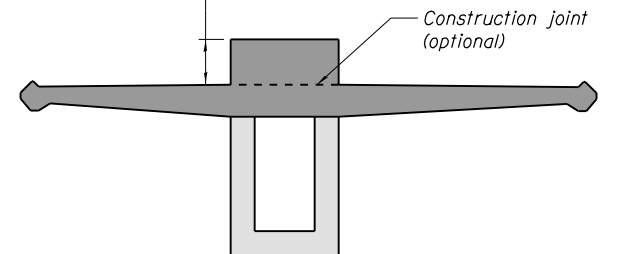

**SECTION C9-C9**

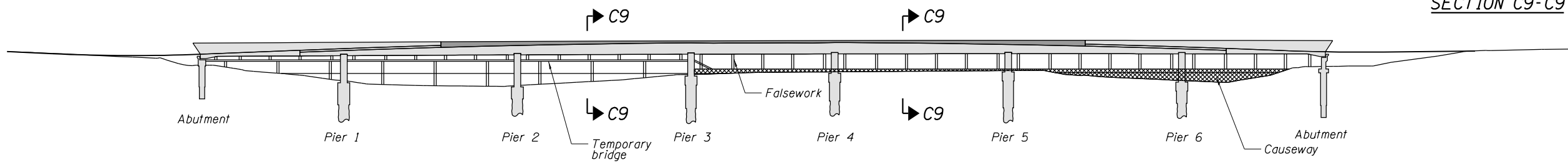

**CONSTRUCTION SEQUENCE 9**  
 9.1 Complete superstructure pours.  
 9.2 Continue bridge lighting conduit installation.

- NOTES:**
1. Recommended construction sequence. Alternatives shall be approved by the engineer.
  2. For future utilities details, see "FUTURE UTILITIES" sheet.
  3. For Bridge lighting conduit details see "BRIDGE LIGHTING DETAILS" sheet.
  4. Temporary bridge and falsework shown are schematic.
  5. Horizontal temporary bridge elements shall be placed above 100-year flood elevation.

FILE NAME = 045P008-XXXX-010-CNSTSE003.dgn

**TY-LIN INTERNATIONAL**

USER NAME = RSTONE	DESIGNED - B. Sokolowski	REVISED - -
	CHECKED - P. Frey	REVISED - -
PLOT SCALE = NO SCALE	DRAWN - I. Martin	REVISED - -
PLOT DATE = 10/19/2017	CHECKED - D. Fitzwilliam	REVISED - -

**STATE OF ILLINOIS  
 DEPARTMENT OF TRANSPORTATION**

**RECOMMENDED CONSTRUCTION SEQUENCE 3  
 STRUCTURE NO. 045-P008**

SHEET NO. S-10 OF S-69 SHEETS

F.A.U. RTE.	SECTION	COUNTY	TOTAL SHEETS	SHEET NO.
2503	16-00313-00-MS	KANE	254	171
CONTRACT NO.				61E18

ILLINOIS FED. AID PROJECT

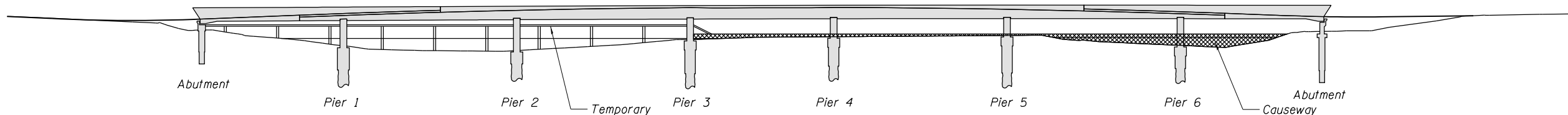

**CONSTRUCTION SEQUENCE 10**

Removal of falsework  
10.1 Release superstructure from falsework support.

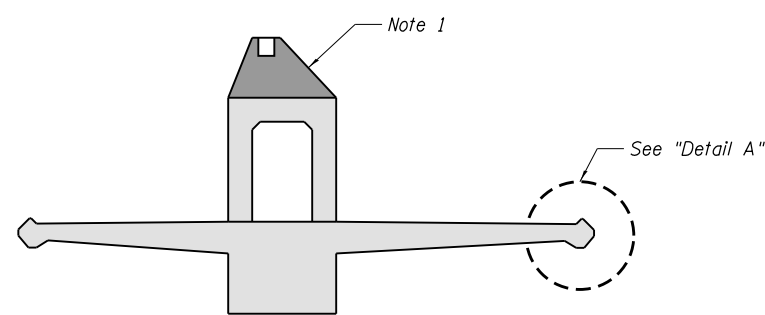

**SECTION A11-A11**

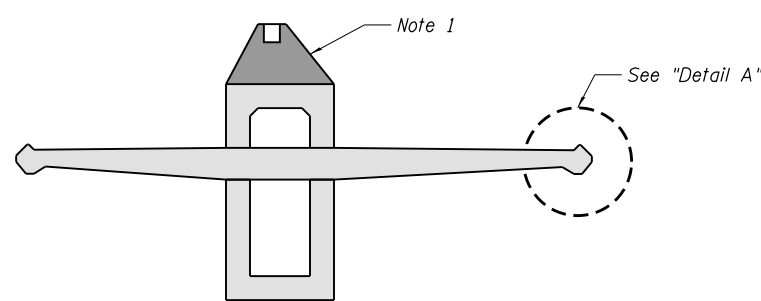

**SECTION B11-B11**

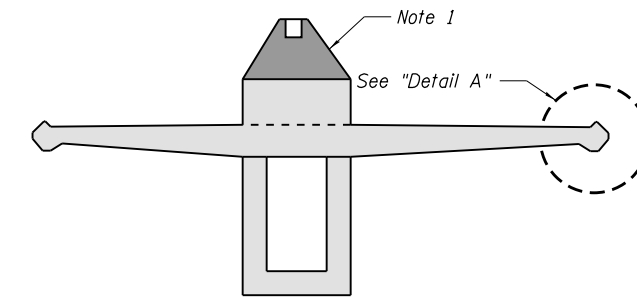

**SECTION C11-C11**

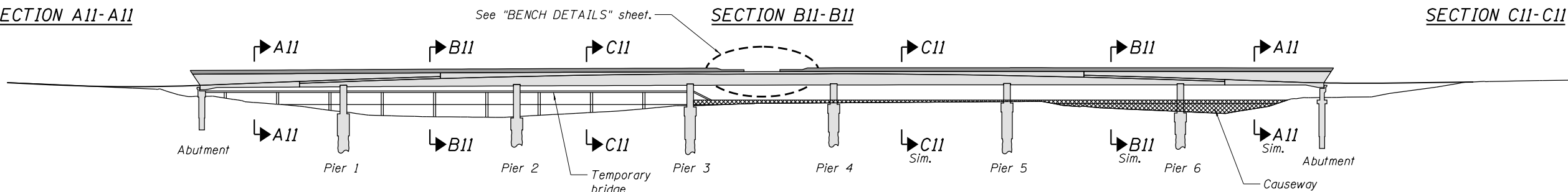

**CONSTRUCTION SEQUENCE 11**

11.1 Pour architectural cornice and bench.  
11.2 Complete bridge lighting conduit installation.

Portion may be poured during Construction Sequence 11. See "SUPERSTRUCTURE 1" Sheet for Joint Dimensions.

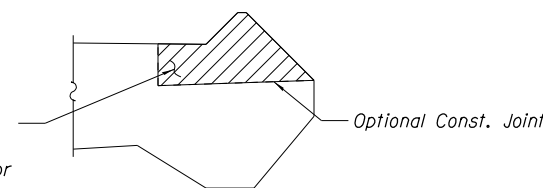

**DETAIL A**

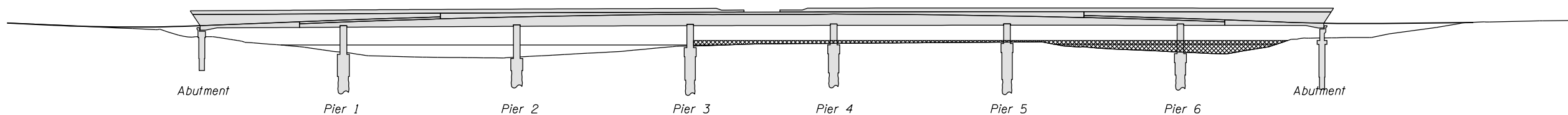

**CONSTRUCTION SEQUENCE 12**

Removal of Temporary Bridge and berm  
12.1 Deck architectural treatment.  
12.2 Remove causeway and temporary bridge.  
12.3 Install railing.

**NOTES:**

1. Recommended construction sequence. Alternatives shall be approved by the engineer.
2. For future utilities details, see "FUTURE UTILITIES" sheet.
3. For Bridge lighting conduit details see "BRIDGE LIGHTING DETAILS" sheet.
4. Architectural cornice geometry varies, see "ARCHITECTURAL CORNICE DETAILS" sheet.
5. False work must be released prior to pouring architectural cornice.
6. Temporary bridge shown is schematic.
7. Horizontal temporary bridge elements shall be placed above 100-year flood elevation.

FILE NAME = 045P008-XXXX-011-CNSTSE004.dgn

**TY-LIN INTERNATIONAL**

USER NAME = RSTONE	DESIGNED - B. Sokolowski	REVISED - -
	CHECKED - P. Frey	REVISED - -
PLOT SCALE = NO SCALE	DRAWN - I. Martin	REVISED - -
PLOT DATE = 10/19/2017	CHECKED - D. Fitzwilliam	REVISED - -

**STATE OF ILLINOIS  
DEPARTMENT OF TRANSPORTATION**

**RECOMMENDED CONSTRUCTION SEQUENCE NO.4  
STRUCTURE NO. 045-P008**

SHEET NO. S-11 OF S-69 SHEETS

F.A.U. RTE.	SECTION	COUNTY	TOTAL SHEETS	SHEET NO.
2503	16-00313-00-MS	KANE	254	172
CONTRACT NO.			61E18	

ILLINOIS FED. AID PROJECT



- NOTES:
- Deck depth varies in span 4 only. Depth is 1'-4" at  $\bar{C}$  Pier 3 and  $\bar{C}$  Pier 4. Depth is 1'-7" at Mid Bridge Station 105+05. Depth varies linearly in between.
  - Width varies in span 4 only. see "OVERLOOK DETAIL" on "GEOMETRY DATA" sheet for more details.
  - All b and g reinforcement shall be made continuous with staggered lap slices. Stagger shall be separated by one lap length between bar terminations. #8 b reinforcement shall be lapped 4'-9". #5 b reinforcement shall be lapped 3'-0". #6 g reinforcement shall be lapped 3'-6".
  - Bars s<sub>8</sub>, s<sub>9</sub>, s<sub>10</sub>, and s<sub>11</sub> shall be spaced along with vertical stirrups s<sub>1</sub>-s<sub>7</sub>.
  - See Soffit Vent Detail on "SUPERSTRUCTURE DETAILS 3" sheet.

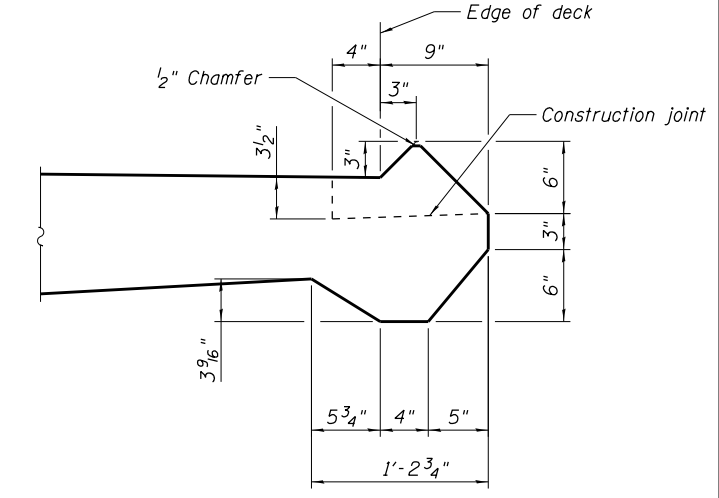
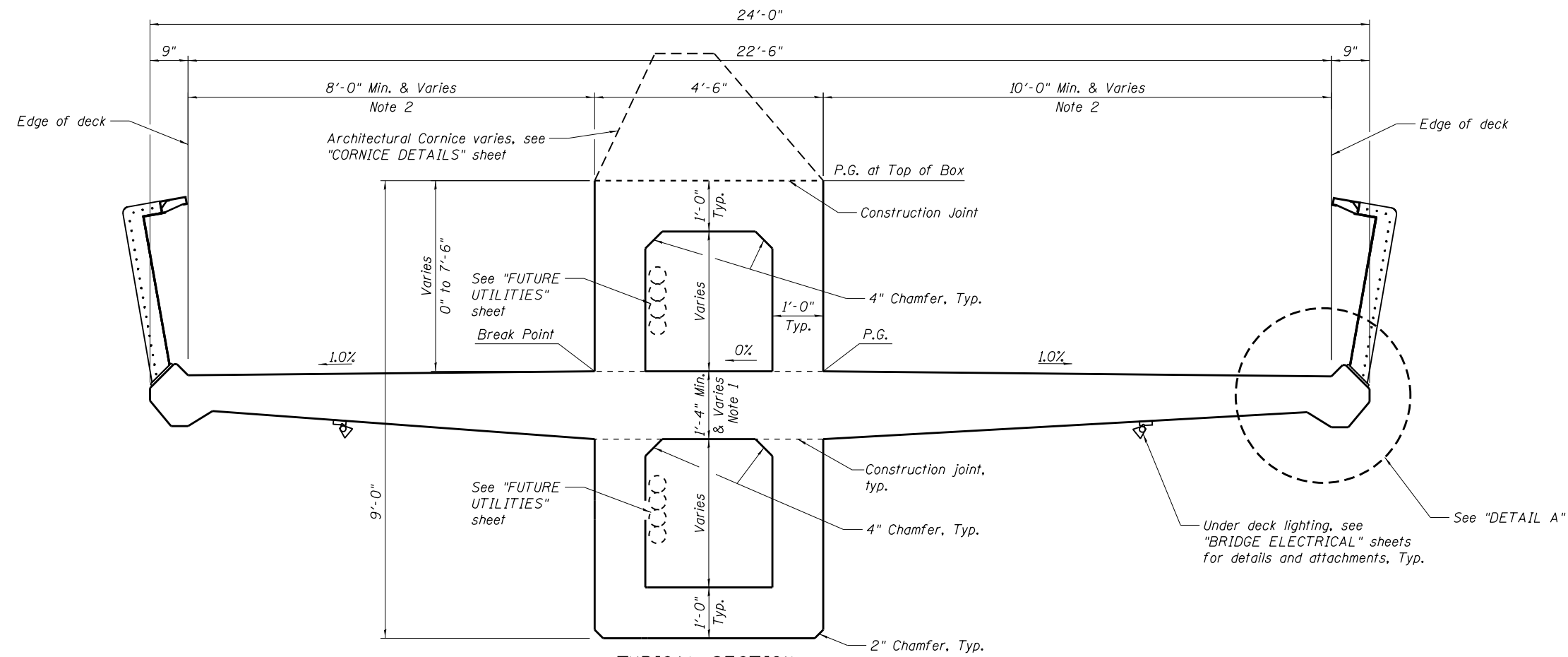

**DETAIL A**

**TYPICAL SECTION**

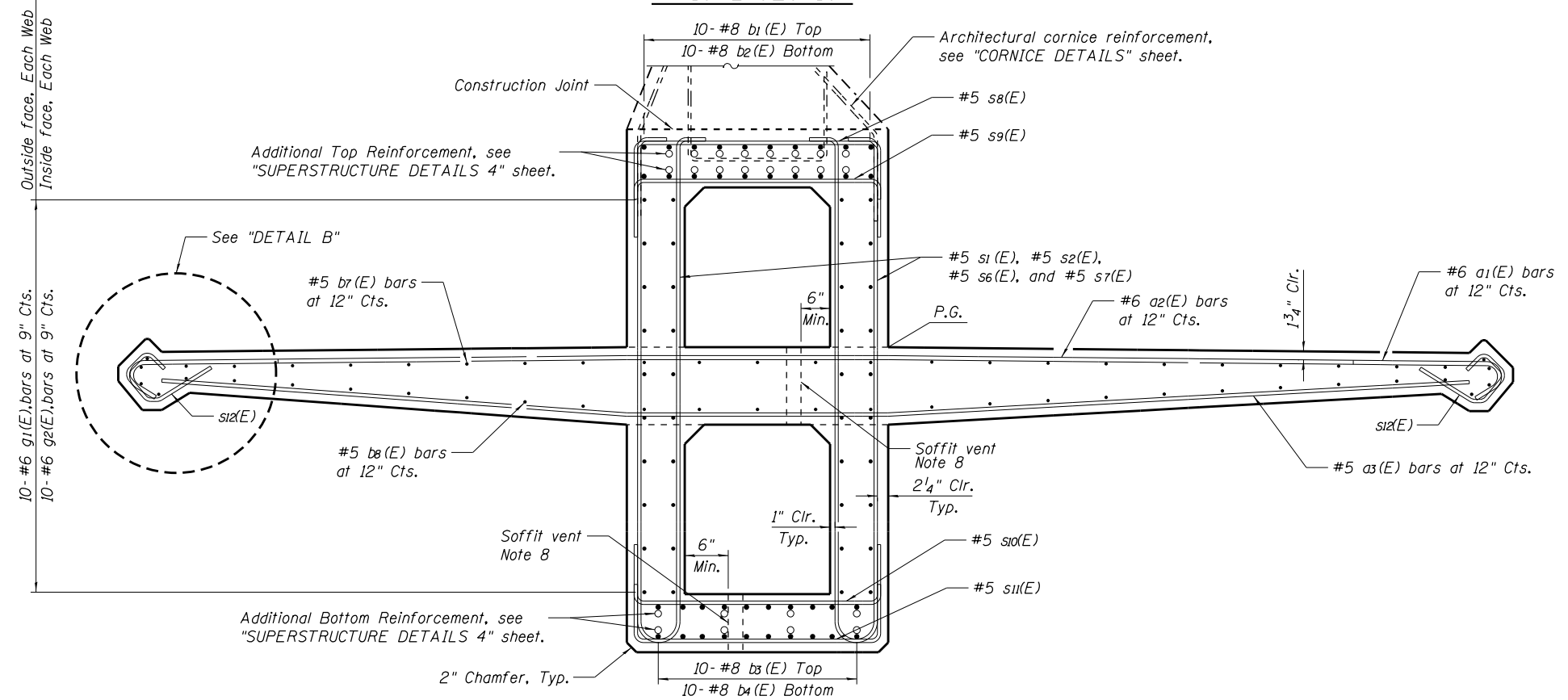

**SECTION - REINFORCEMENT**

Stations: 101+95.59 to 102+89.91  
107+20.45 to 108+14.72

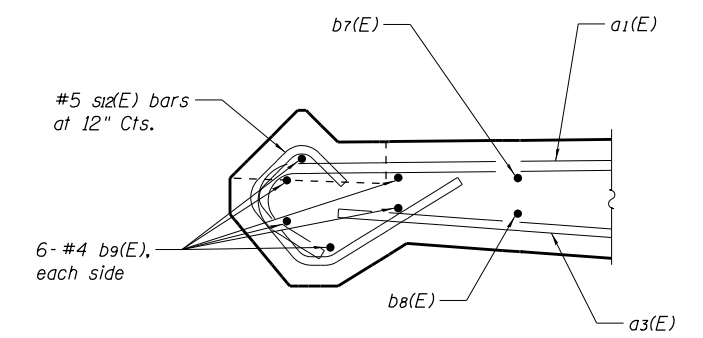

**DETAIL B**

FILE NAME = 045P008-XXXX-012-SUPERSTR01.dgn

	USER NAME = RSTONE	DESIGNED - B. Sokolowski	REVISED - -	<b>STATE OF ILLINOIS</b> <b>DEPARTMENT OF TRANSPORTATION</b>	<b>SUPERSTRUCTURE 1</b> <b>STRUCTURE NO. 045-P008</b>	F.A.U. R.T.E.	SECTION	COUNTY	TOTAL SHEETS	SHEET NO.
	PLOT SCALE = NO SCALE	CHECKED - P. Frey	REVISED - -			2503	16-00313-00-MS	KANE	254	173
	PLOT DATE = 10/19/2017	DRAWN - O. Colcol	REVISED - -			CONTRACT NO.		61E18		

ILLINOIS FED. AID PROJECT

FILE NAME = 045P008-XXXX-013-SUPERSTR02.dgn

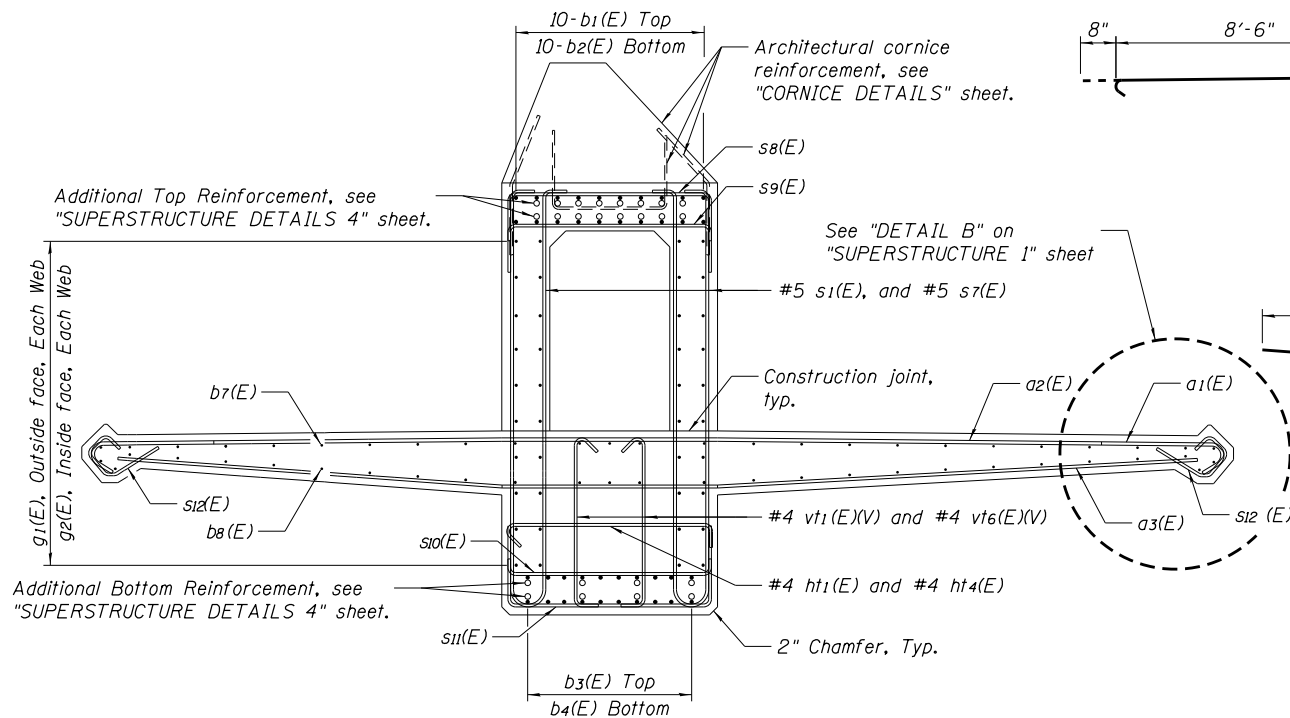

**SECTION - REINFORCEMENT**  
Stations: 101+42.75 to 101+95.59  
108+14.72 to 108+67.25

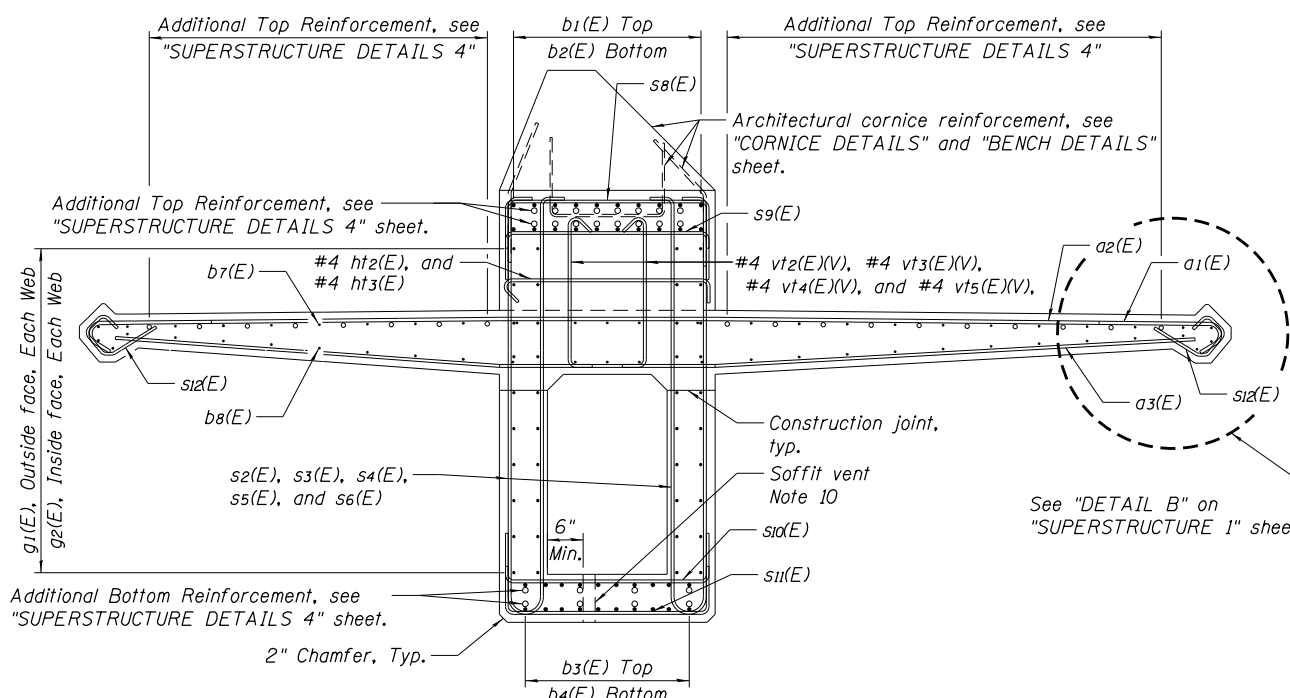

**SECTION - REINFORCEMENT**  
Stations: 102+89.91 to 104+29.27  
105+79.14 to 107+20.45

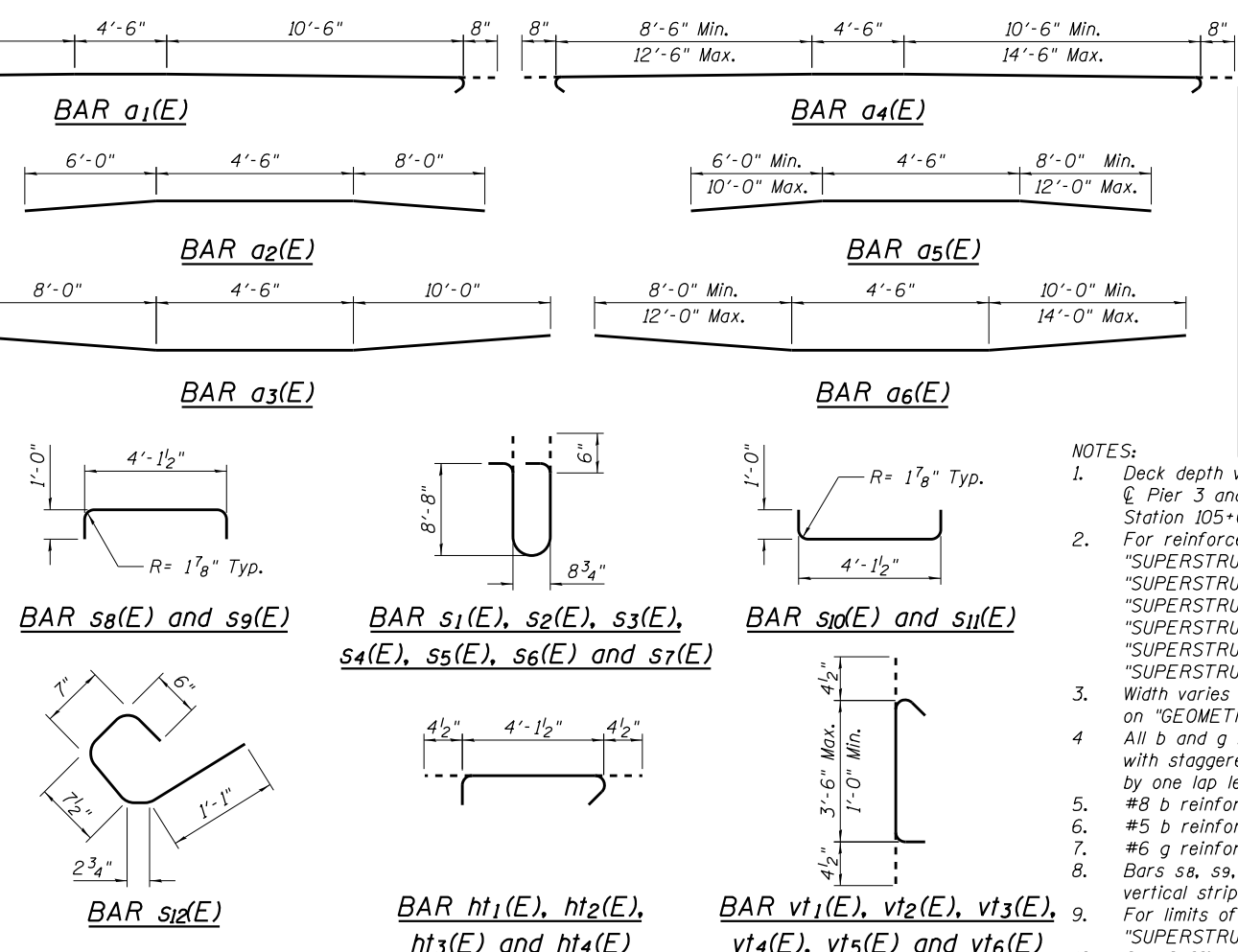

**SUPERSTRUCTURE BILL OF MATERIAL**

Bar	No.	Size	Length	Shape	
b <sub>1</sub> (E)	170	#8	40'-0"	—	
b <sub>2</sub> (E)	150	#8	40'-0"	—	
b <sub>3</sub> (E)	210	#8	40'-0"	—	
b <sub>4</sub> (E)	210	#8	40'-0"	—	
b <sub>5</sub> (E)	80	#8	40'-0"	—	
b <sub>6</sub> (E)	50	#8	40'-0"	—	
b <sub>7</sub> (E)	441	#5	40'-0"	—	
b <sub>8</sub> (E)	441	#5	40'-0"	—	
b <sub>9</sub> (E)	252	#4	40'-0"	—	
g <sub>1</sub> (E)	420	#6	40'-0"	—	
g <sub>2</sub> (E)	420	#6	40'-0"	—	
Reinforcement Bars, Epoxy Coated				Lbs.	186,914

- NOTES:**
- Deck depth varies in span 4 only. Depth is 1'-4" at C/Pier 3 and C/Pier 4. Depth is 1'-7" at Mid Bridge Station 105+05. Depth varies linearly in between.
  - For reinforcement extents not shown, see "SUPERSTRUCTURE DETAILS 1", "SUPERSTRUCTURE DETAILS 2", "SUPERSTRUCTURE DETAILS 3", "SUPERSTRUCTURE DETAILS 4", "SUPERSTRUCTURE DETAILS 5" and "SUPERSTRUCTURE DETAILS 6".
  - Width varies in span 4 only. see "OVERLOOK DETAIL" on "GEOMETRY DATA" sheet for more details.
  - All b and g reinforcement shall be made continuous with staggered lap slices. Stagers shall be separated by one lap length between bar terminations.
  - #8 b reinforcement shall be lapped 4'-9".
  - #5 b reinforcement shall be lapped 3'-0".
  - #6 g reinforcement shall be lapped 3'-6".
  - Bars s<sub>8</sub>, s<sub>9</sub>, s<sub>10</sub> and s<sub>11</sub> shall be spaced along with vertical stripes s<sub>1</sub>-s<sub>7</sub>.
  - For limits of s<sub>9</sub> bars not shown, see "SUPERSTRUCTURE DETAILS 1 & 2" sheets.
  - See Soffit Vent Detail on "SUPERSTRUCTURE DETAILS 3" sheet.

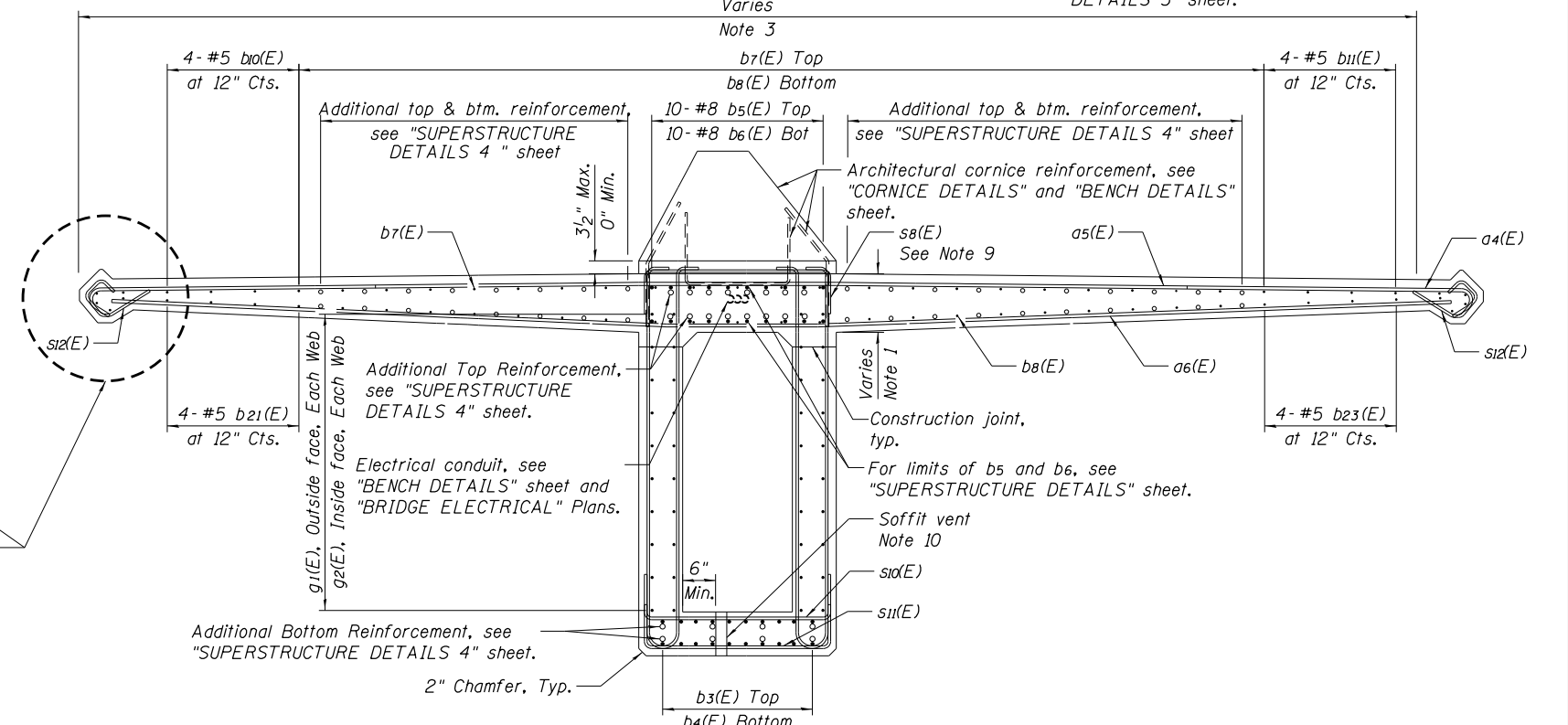

**SECTION - REINFORCEMENT**  
Stations: 104+29.27 to 105+79.14

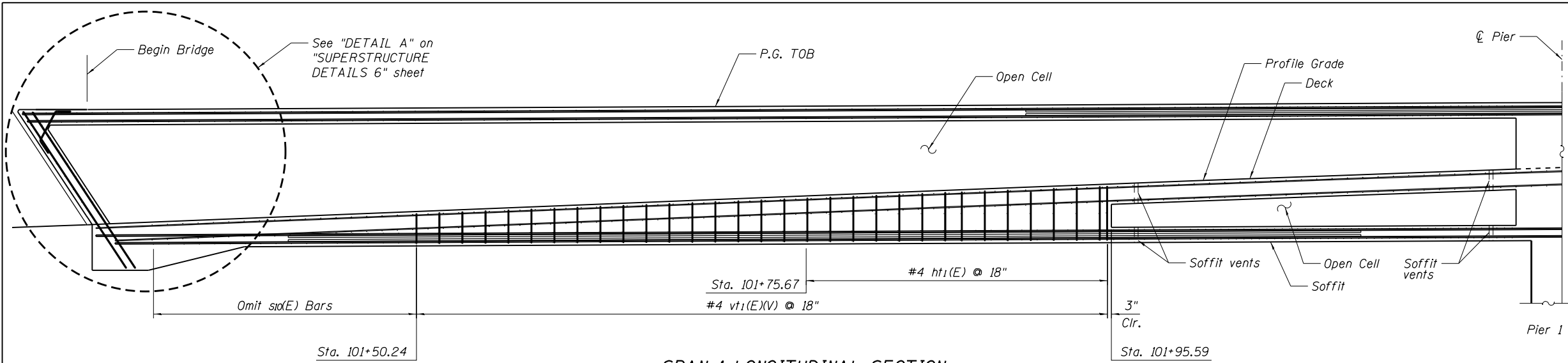

**SPAN 1 LONGITUDINAL SECTION**

**SUPERSTRUCTURE BILL OF MATERIAL**

Bar	No.	Size	Length	Shape
vt <sub>1</sub> (E) Max	32	#4	4'-3"	U
vt <sub>1</sub> (E) Min	30	#4	1'-9"	U
vt <sub>2</sub> (E) Max	34	#4	4'-3"	U
vt <sub>2</sub> (E) Min	32	#4	2'-3"	U
vt <sub>3</sub> (E) Max	18	#4	2'-3"	U
vt <sub>3</sub> (E) Min	16	#4	1'-9"	U
ht <sub>1</sub> (E)	14	#4	4'-10½"	U
ht <sub>2</sub> (E)	23	#4	4'-10½"	U
Reinforcement Bars, Epoxy Coated			Lbs.	437

NOTE:  
1. For details not shown, see "SUPERSTRUCTURE 1" and "SUPERSTRUCTURE 2" sheets.

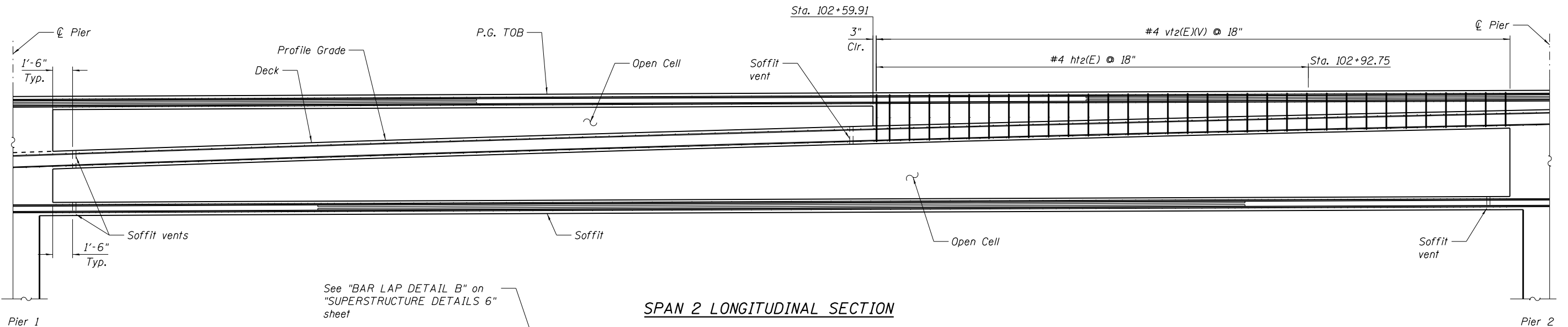

**SPAN 2 LONGITUDINAL SECTION**

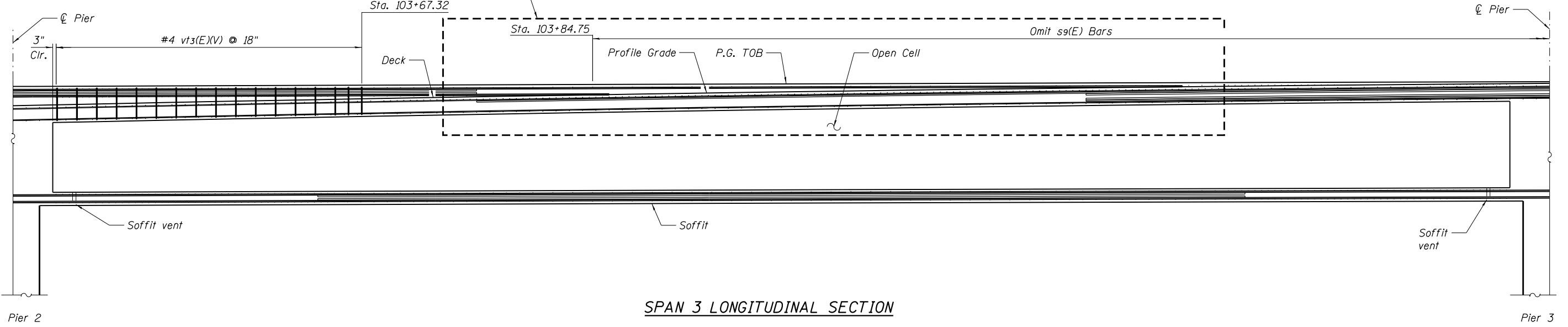

**SPAN 3 LONGITUDINAL SECTION**

FILE NAME = 045P008-XXXX-014-SUPERSTRDE101.dgn

<b>TY-LIN INTERNATIONAL</b>	USER NAME = RSTONE	DESIGNED - B. Sokolowski	REVISED - -	<b>STATE OF ILLINOIS DEPARTMENT OF TRANSPORTATION</b>	<b>SUPERSTRUCTURE DETAILS 1 STRUCTURE NO. 045-P008</b>	F.A.U. RTE. 2503	SECTION 16-00313-00-MS	COUNTY KANE	TOTAL SHEETS 254	SHEET NO. 175
	PLOT SCALE = NO SCALE	DRAWN - I. Martin	REVISED - -			CONTRACT NO. 61E18				
	PLOT DATE = 10/19/2017	CHECKED - D. Fitzwilliam	REVISED - -			ILLINOIS FED. AID PROJECT				
	SHEET NO. S-14 OF S-69 SHEETS									

**SUPERSTRUCTURE  
BILL OF MATERIAL**

Bar	No.	Size	Length	Shape
vt <sub>4</sub> (E) Max	16	#4	2'-3"	⌒
vt <sub>4</sub> (E) Min	16	#4	1'-9"	⌒
vt <sub>5</sub> (E) Max	34	#4	4'-3"	⌒
vt <sub>5</sub> (E) Min	32	#4	1'-9"	⌒
ht <sub>3</sub> (E)	27	#4	4'-10½"	⌒
Reinforcement Bars, Epoxy Coated			Lbs.	265

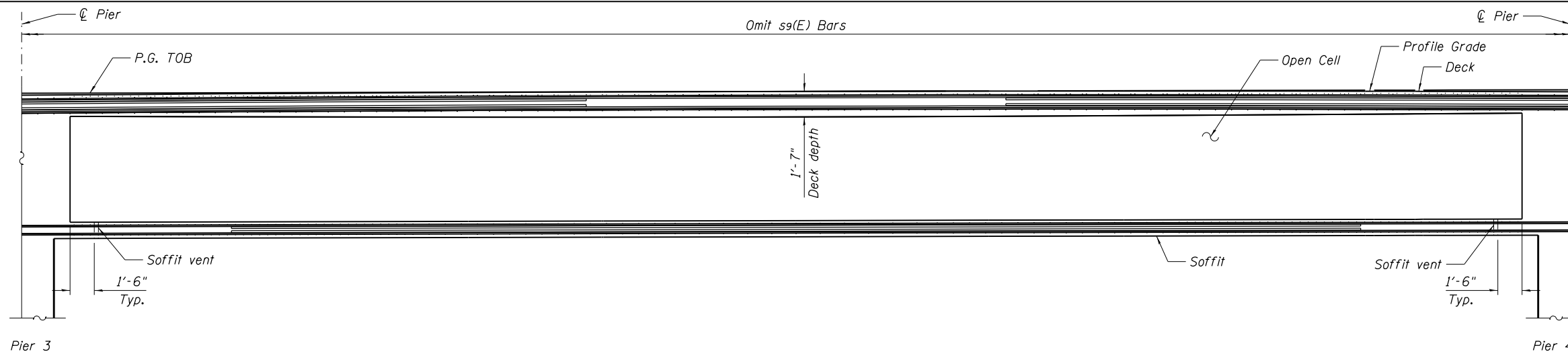

**MID SPAN LONGITUDINAL SECTION**

NOTE:  
1. For details not shown, see "SUPERSTRUCTURE 1" and "SUPERSTRUCTURE 2" sheets.

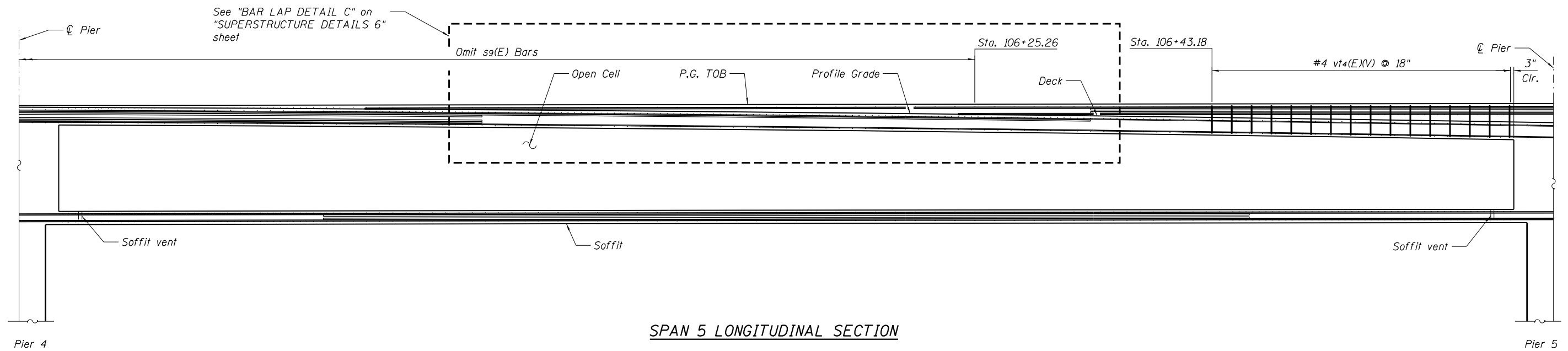

**SPAN 5 LONGITUDINAL SECTION**

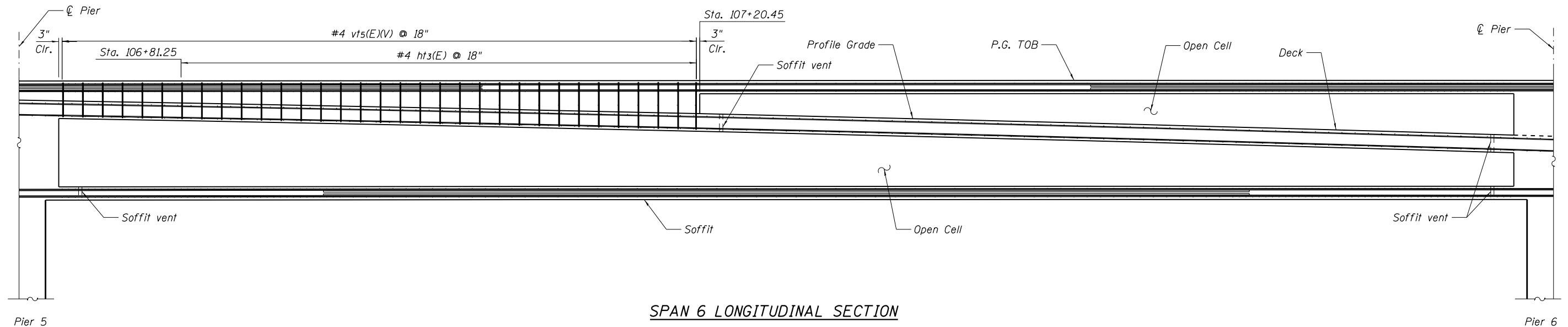

**SPAN 6 LONGITUDINAL SECTION**

FILE NAME = 045P008-XXXX-015-SUPERSTRDE102.dgn

**TY-LIN INTERNATIONAL**

USER NAME = RSTONE	DESIGNED - B. Sokolowski	REVISED - -
PLOT SCALE = NO SCALE	CHECKED - P. Frey	REVISED - -
PLOT DATE = 10/19/2017	DRAWN - I. Martin	REVISED - -
	CHECKED - D. Fitzwilliam	REVISED - -

**STATE OF ILLINOIS  
DEPARTMENT OF TRANSPORTATION**

**SUPERSTRUCTURE DETAILS 2  
STRUCTURE NO. 045-P008**

SHEET NO. S-15 OF S-69 SHEETS

F.A.U. RTE.	SECTION	COUNTY	TOTAL SHEETS	SHEET NO.
2503	16-00313-00-MS	KANE	254	176
CONTRACT NO.			61E18	
ILLINOIS FED. AID PROJECT				

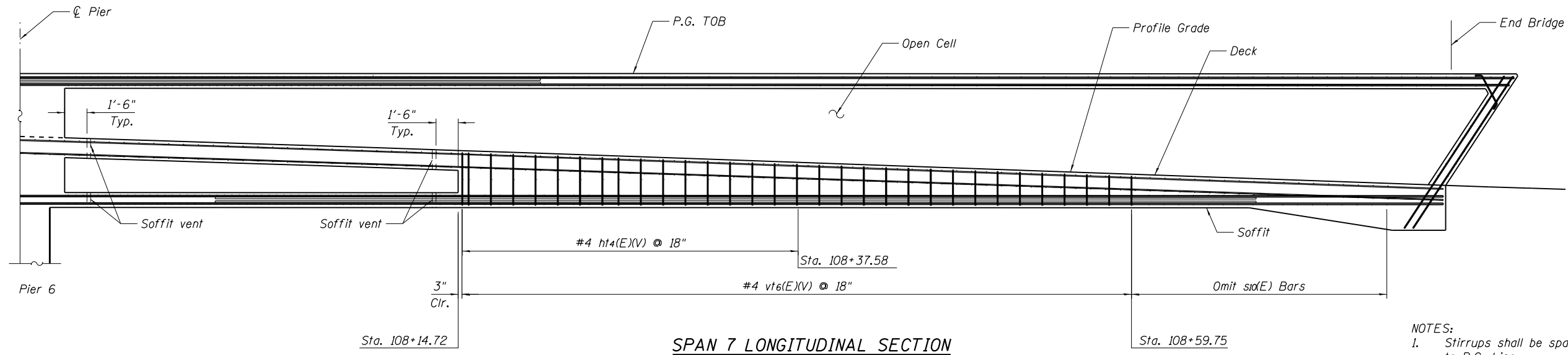

- NOTES:
1. Stirrups shall be spaced along and placed perpendicular to P.G. Line
  2. For details not shown, see "SUPERSTRUCTURE 1" and "SUPERSTRUCTURE 2" sheets.

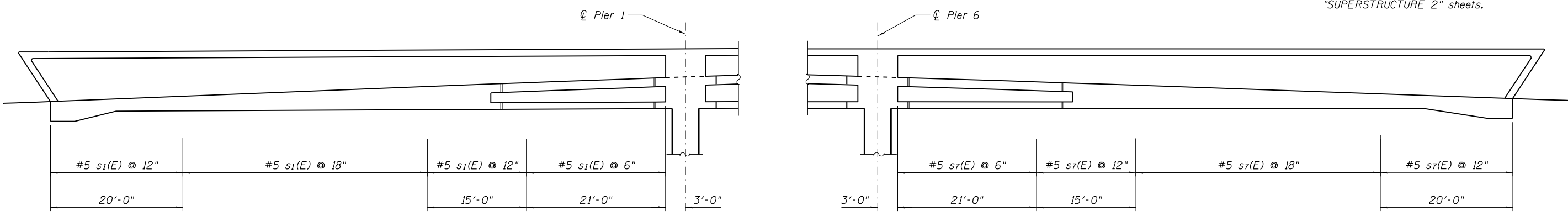

SHEAR STIRRUP SCHEDULE

SHEAR STIRRUP SCHEDULE

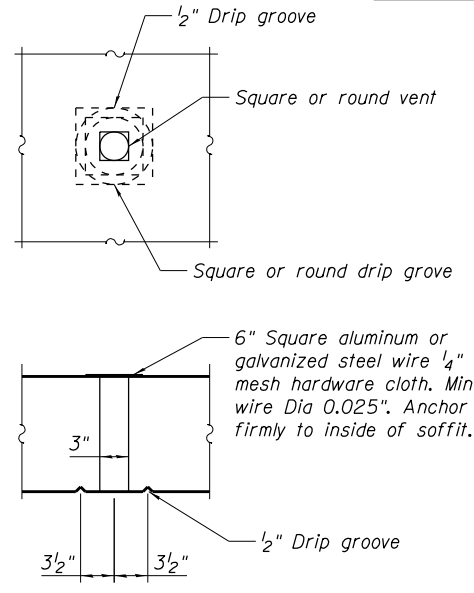

SOFFIT VENT DETAIL

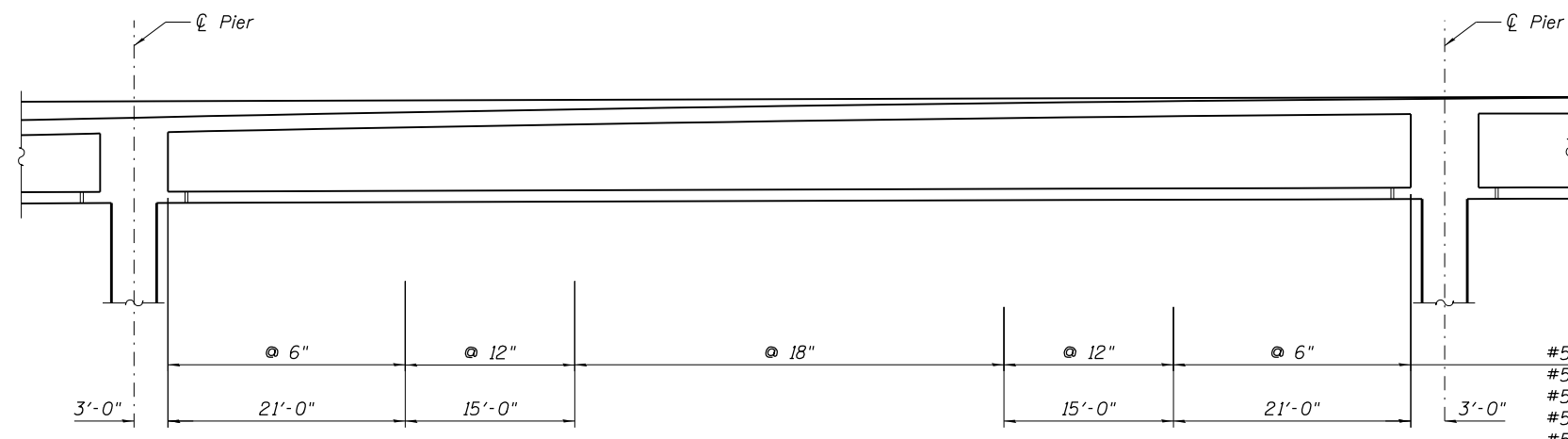

SHEAR STIRRUP SCHEDULE

SUPERSTRUCTURE BILL OF MATERIAL

Bar	No.	Size	Length	Shape
s <sub>1</sub> (E)	208	#5	18'-9"	U
s <sub>2</sub> (E)	282	#5	18'-9"	U
s <sub>3</sub> (E)	282	#5	18'-9"	U
s <sub>4</sub> (E)	256	#5	18'-9"	U
s <sub>5</sub> (E)	282	#5	18'-9"	U
s <sub>6</sub> (E)	282	#5	18'-9"	U
s <sub>7</sub> (E)	208	#5	18'-9"	U
s <sub>8</sub> (E)	900	#5	6'-1 1/2"	U
s <sub>9</sub> (E)	614	#5	6'-1 1/2"	U
s <sub>10</sub> (E)	848	#5	6'-1 1/2"	U
s <sub>11</sub> (E)	900	#5	6'-1 1/2"	U
s <sub>12</sub> (E)	1450	#5	3'-1 1/2"	U
vt <sub>6</sub> (E) Max	32	#4	4'-3"	U
vt <sub>6</sub> (E) Min	30	#4	1'-9"	U
ht <sub>4</sub> (E)	15	#4	4'-10 1/2"	U
Reinforcement Bars, Epoxy Coated		Lbs.		60,813
Concrete Superstructure		Cu. Yds.		1,356

FILE NAME = 045P008-XXXX-016-SUPERSTRDE103.dgn

8-#5 d121(E),  
place between  
b7(E) bars in deck  
(at Pier 2)  
8-#5 d151(E),  
place between  
b7(E) bars in deck  
(at Pier 5)

10-#5 d122(E),  
place between  
b7(E) bars in deck  
(at Pier 2)  
10-#5 d152(E),  
place between  
b7(E) bars in deck  
(at Pier 5)

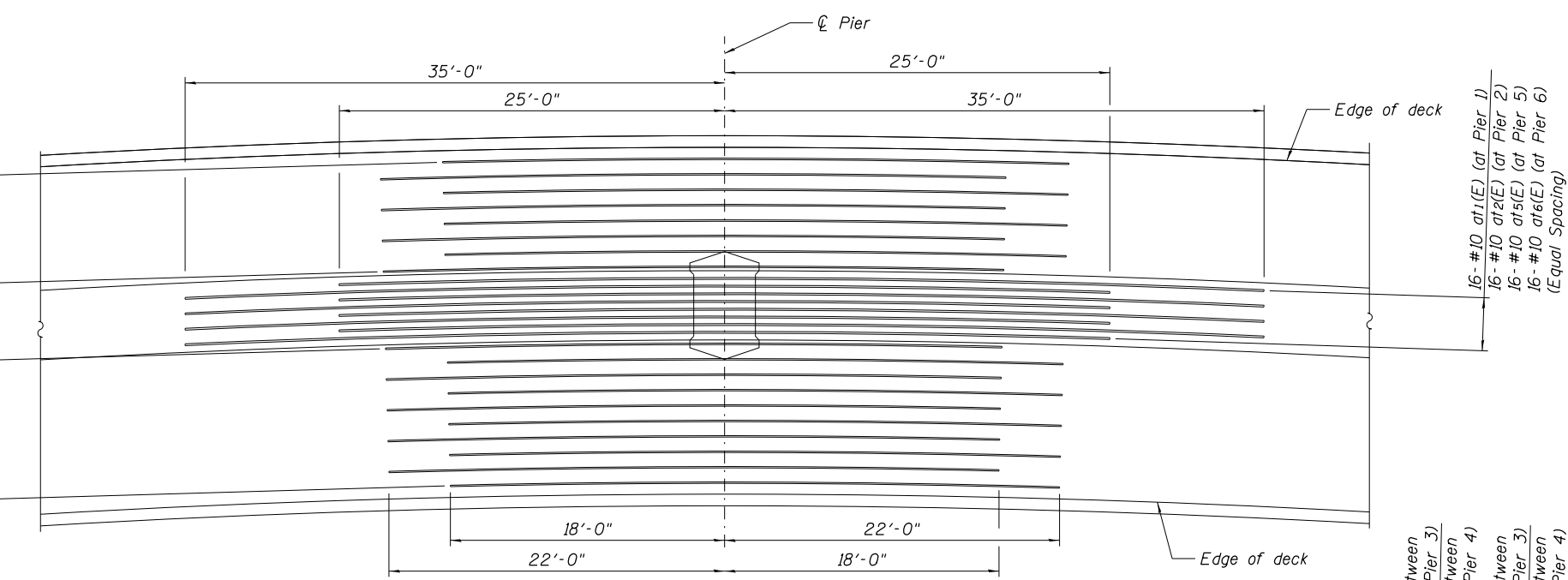
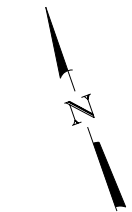

**ADDITIONAL TOP REINFORCEMENT AT PIERS 1, 2, 5 & 6**

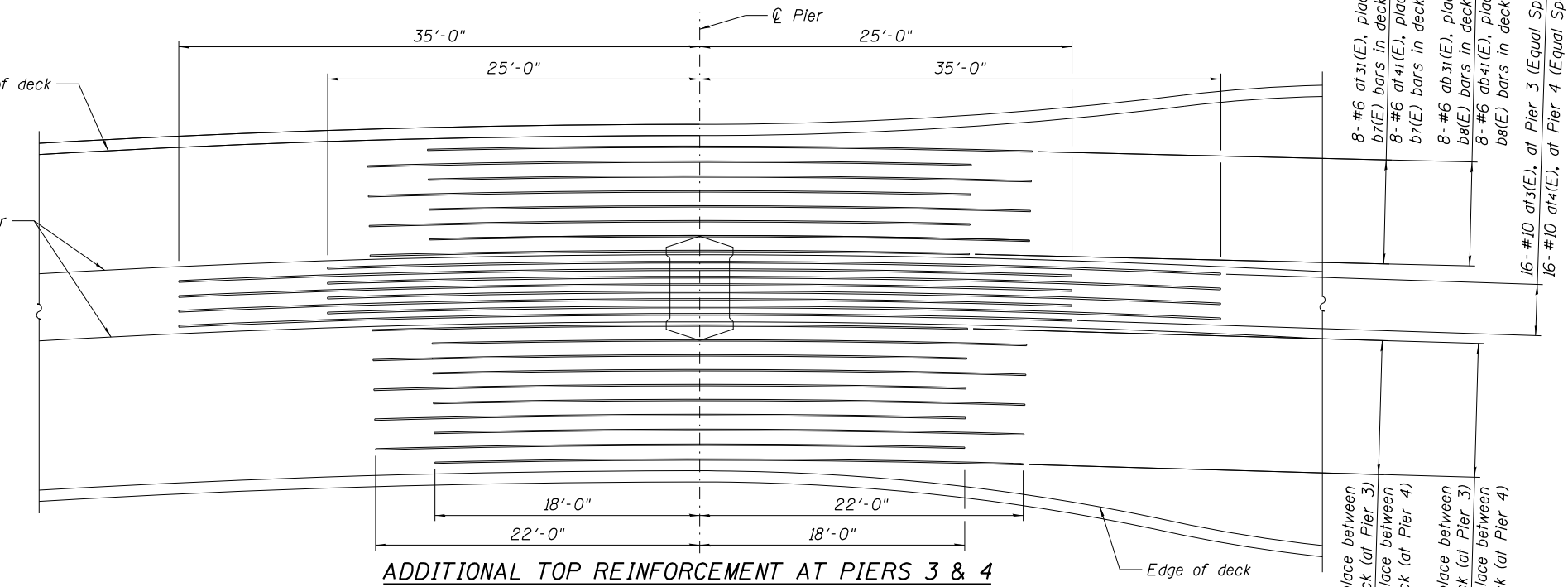

**ADDITIONAL TOP REINFORCEMENT AT PIERS 3 & 4**

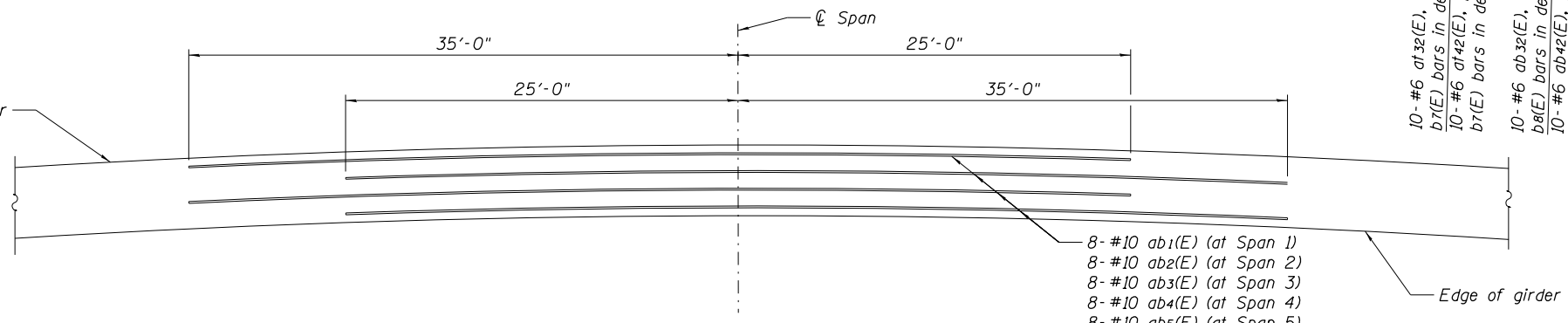

**ADDITIONAL BOTTOM REINFORCEMENT SPANS 1 - 7**

8-#10 ab1(E) (at Span 1)  
8-#10 ab2(E) (at Span 2)  
8-#10 ab3(E) (at Span 3)  
8-#10 ab4(E) (at Span 4)  
8-#10 ab5(E) (at Span 5)  
8-#10 ab6(E) (at Span 6)  
8-#10 ab7(E) (at Span 7)  
(Equal Spacing)

- NOTES:
1. Typical reinforcement omitted for clarity.
  2. For typical section, see "SUPERSTRUCTURE 1" and "SUPERSTRUCTURE 2" sheets.
  3. Additional reinforcement shall be continuous bars.
  4. Additional reinforcement shall be placed as shown on "SUPERSTRUCTURE DETAIL No. 1".

**ADDITIONAL SUPERSTRUCTURE  
BILL OF MATERIAL**

Bar	No.	Size	Length	Shape
at1(E)	16	#10	60'-0"	—
at2(E)	16	#10	60'-0"	—
at3(E)	16	#10	60'-0"	—
at4(E)	16	#10	60'-0"	—
at5(E)	16	#10	60'-0"	—
at6(E)	16	#10	60'-0"	—
ab1(E)	8	#10	60'-0"	—
ab2(E)	8	#10	60'-0"	—
ab3(E)	8	#10	60'-0"	—
ab4(E)	8	#10	60'-0"	—
ab5(E)	8	#10	60'-0"	—
ab6(E)	8	#10	60'-0"	—
ab7(E)	8	#10	60'-0"	—
ab31(E)	8	#6	40'-0"	—
ab41(E)	8	#6	40'-0"	—
ab32(E)	10	#6	40'-0"	—
ab42(E)	10	#6	40'-0"	—
at21(E)	8	#5	40'-0"	—
at31(E)	8	#6	40'-0"	—
at41(E)	8	#6	40'-0"	—
at51(E)	8	#5	40'-0"	—
at22(E)	10	#5	40'-0"	—
at32(E)	10	#6	40'-0"	—
at42(E)	10	#6	40'-0"	—
at52(E)	10	#5	40'-0"	—
Reinforcement Bars, Epoxy Coated			Lbs.	45,072

FILE NAME = 045P008-XXXX-017-SUPERSTRDE104.dgn

<b>TYLIN</b> INTERNATIONAL	USER NAME = RSTONE	DESIGNED - B. Sokolowski	REVISED - -
	PLOT SCALE = NO SCALE	CHECKED - P. Frey	REVISED - -
	PLOT DATE = 10/19/2017	DRAWN - I. Martin	REVISED - -
		CHECKED - D. Fitzwilliam	REVISED - -

**STATE OF ILLINOIS  
DEPARTMENT OF TRANSPORTATION**

**SUPERSTRUCTURE DETAILS 4  
STRUCTURE NO. 045-P008**

SHEET NO. S-17 OF S-69 SHEETS

F.A.U. RT.E.	SECTION	COUNTY	TOTAL SHEETS	SHEET NO.
2503	16-00313-00-MS	KANE	254	178
ILLINOIS FED. AID PROJECT			CONTRACT NO.	61E18

- NOTES:
1. Transverse bars shall be spaced along and placed perpendicular or P.G. Line.
  2. All b reinforcement shall be made continuous through staggered lap splices.
  3. Not all reinforcement shown, see "SUPERSTRUCTURE 1" AND SUPERSTRUCTURE 2" for details not shown.

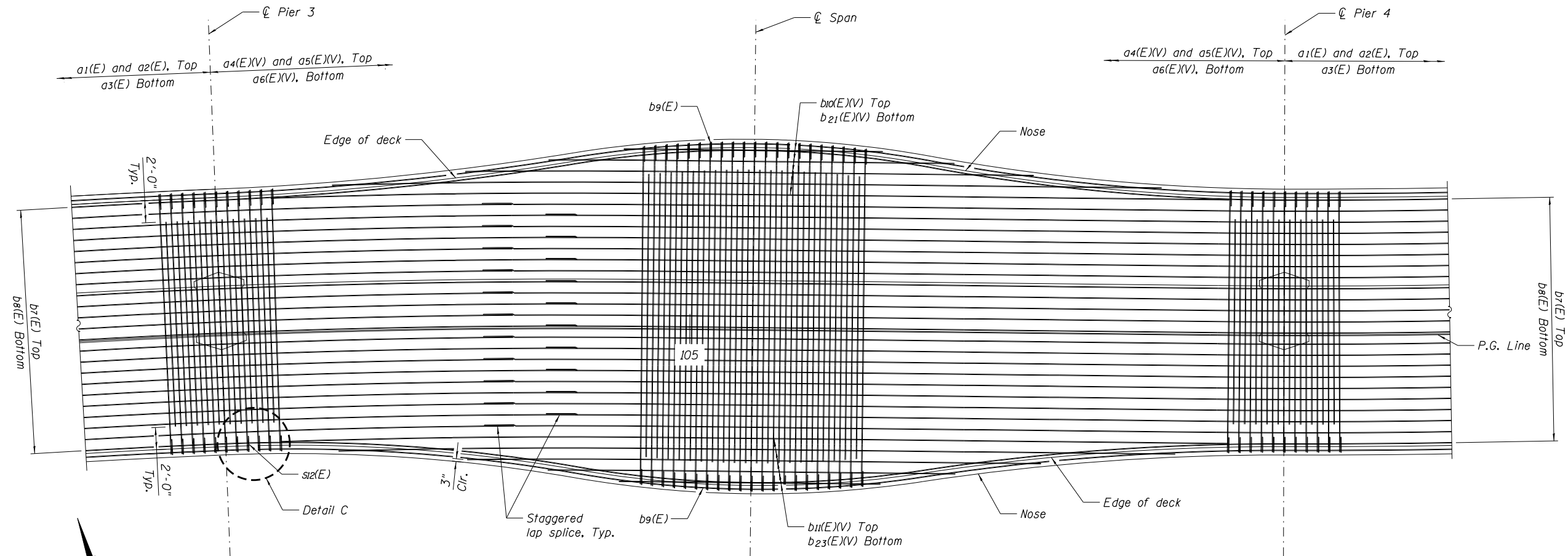

**MID SPAN REINFORCEMENT**

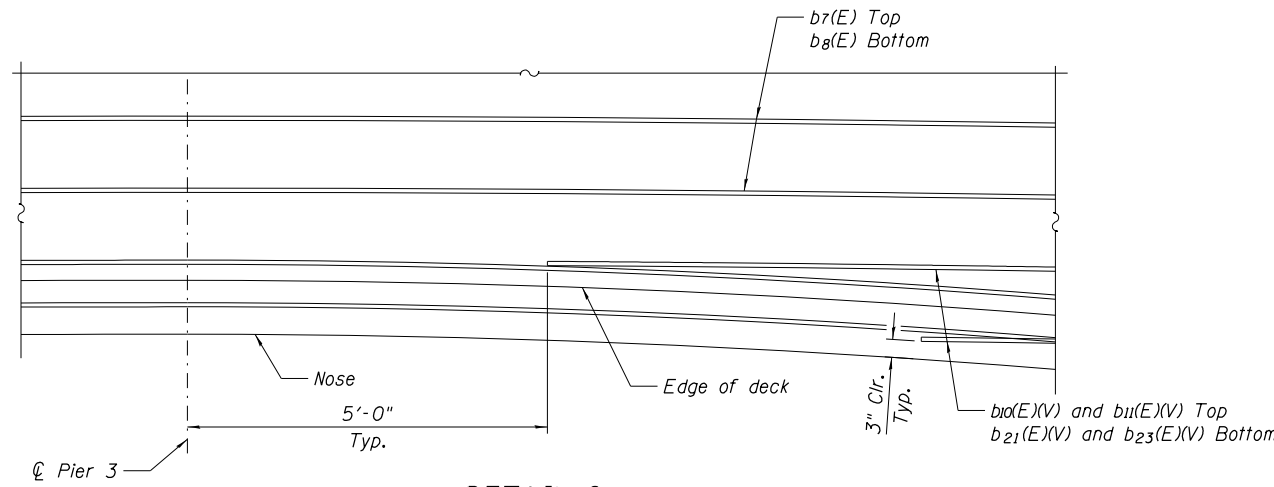

**DETAIL C**  
(Transverse reinforcement not shown for clarity)

**SUPERSTRUCTURE  
BILL OF MATERIAL**

Bar	No.	Size	Length	Shape
a <sub>1</sub> (E)	650	#6	24'-10"	┌───┐
a <sub>2</sub> (E)	650	#6	18'-6"	┌───┐
a <sub>3</sub> (E)	650	#5	22'-6"	┌───┐
a <sub>4</sub> (E) Max	46	#6	32'-10"	┌───┐
a <sub>4</sub> (E) Min	48	#6	24'-10"	┌───┐
a <sub>5</sub> (E) Max	46	#6	26'-6"	┌───┐
a <sub>5</sub> (E) Min	48	#6	18'-6"	┌───┐
a <sub>6</sub> (E) Max	46	#6	30'-6"	┌───┐
a <sub>6</sub> (E) Min	48	#6	22'-6"	┌───┐
b <sub>10</sub> (E) Max	6	#5	40'-0"	───
b <sub>10</sub> (E) Min	3	#5	24'-0"	───
b <sub>11</sub> (E) Max	6	#5	40'-0"	───
b <sub>11</sub> (E) Min	3	#5	24'-0"	───
b <sub>21</sub> (E) Max	6	#5	40'-0"	───
b <sub>21</sub> (E) Min	3	#5	24'-0"	───
b <sub>23</sub> (E) Max	6	#5	40'-0"	───
b <sub>23</sub> (E) Min	3	#5	24'-0"	───
Reinforcement Bars, Epoxy Coated			Lbs.	68,683

FILE NAME = 045P008-XXXX-018-SUPERSTRDE105.dgn

**TYLIN** INTERNATIONAL

USER NAME = RSTONE	DESIGNED - B. Sokolowski	REVISED - -
PLOT SCALE = NO SCALE	CHECKED - P. Frey	REVISED - -
PLOT DATE = 10/19/2017	DRAWN - I. Martin	REVISED - -
	CHECKED - D. Fitzwilliam	REVISED - -

**STATE OF ILLINOIS  
DEPARTMENT OF TRANSPORTATION**

**SUPERSTRUCTURE DETAILS 5  
STRUCTURE NO. 045-P008**

SHEET NO. S-18 OF S-69 SHEETS

F.A.U. RTE.	SECTION	COUNTY	TOTAL SHEETS	SHEET NO.
2503	16-00313-00-MS	KANE	254	179
ILLINOIS FED. AID PROJECT			CONTRACT NO.	61E18

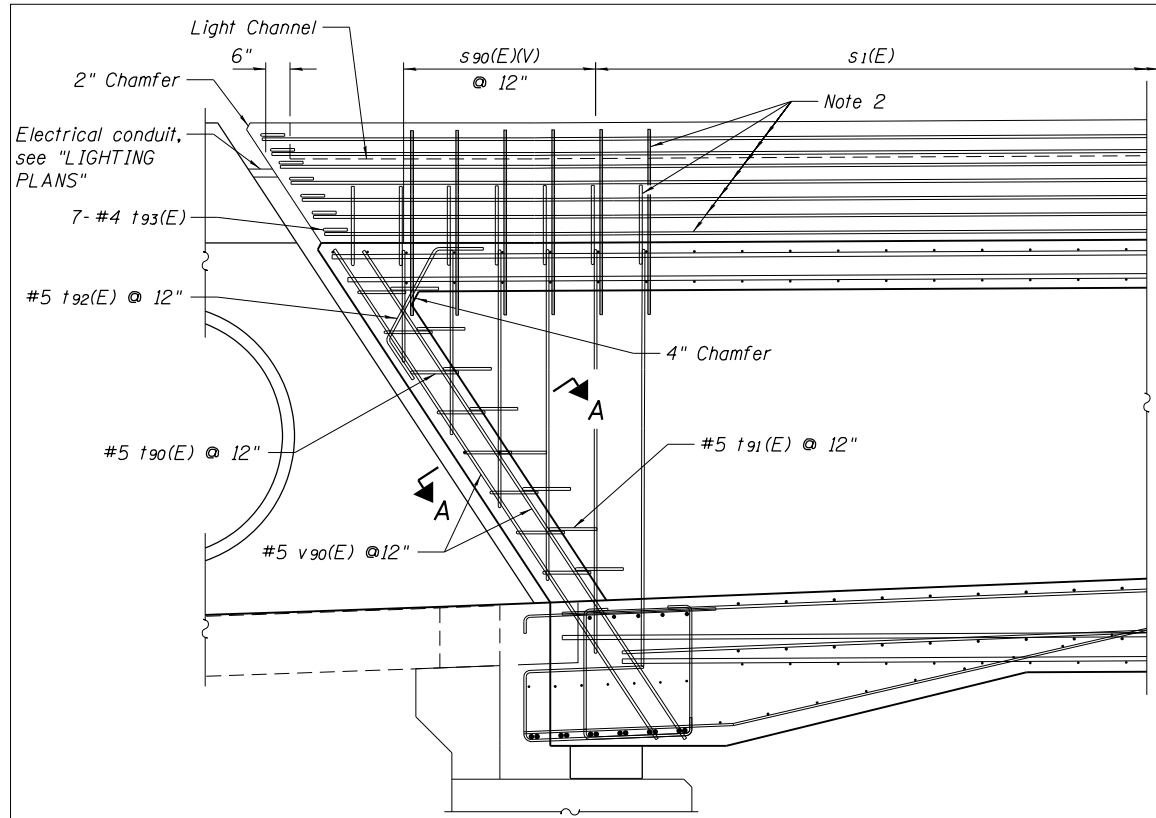

**DETAIL A**  
(West abutment shown East abutment similar)

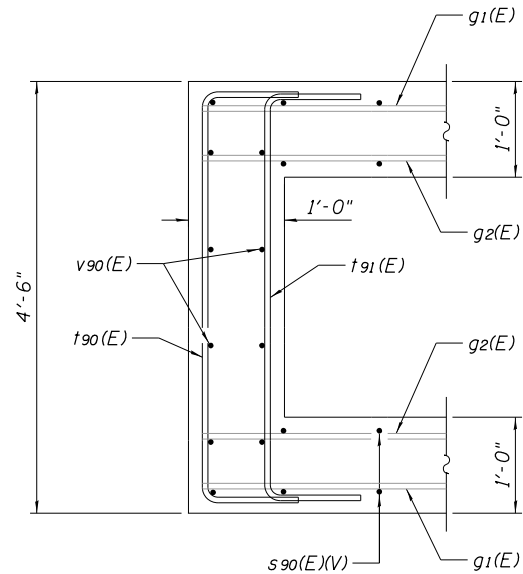

**SECTION A-A**

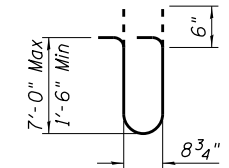

**BAR s90(E)(V)**

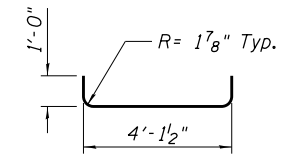

**BAR t90(E) and t91(E)**

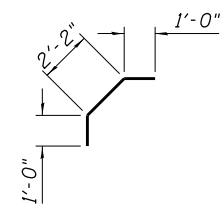

**BAR t92(E)**

- NOTE:**
- For information not shown, see "SUPERSTRUCTURE DETAILS 1", "SUPERSTRUCTURE DETAILS 2", "SUPERSTRUCTURE DETAILS 3", "SUPERSTRUCTURE DETAILS 4" and "SUPERSTRUCTURE DETAILS 5", sheet.
  - Cornice reinforcement, see "CORNICER DETAILS" sheet.

**SUPERSTRUCTURE  
BILL OF MATERIAL**

Bar	No.	Size	Length	Shape
v90(E)	20	#5	10'-0"	—
s90(E) Max	8	#5	15'-6"	U
s90(E) Min	8	#5	4'-6"	U
t90(E)	16	#5	6'-1 1/2"	┌
t91(E)	16	#5	5'-5"	┌
t92(E)	10	#5	4'-2"	┌
t93(E) Max	7	#4	5'-2"	┌
t93(E) Max	7	#4	1'-10"	┌
Reinforcement Bars, Epoxy Coated			Lbs.	644

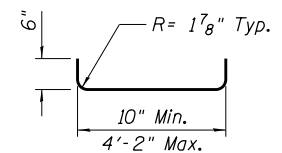

**BAR t93(E)(V)**

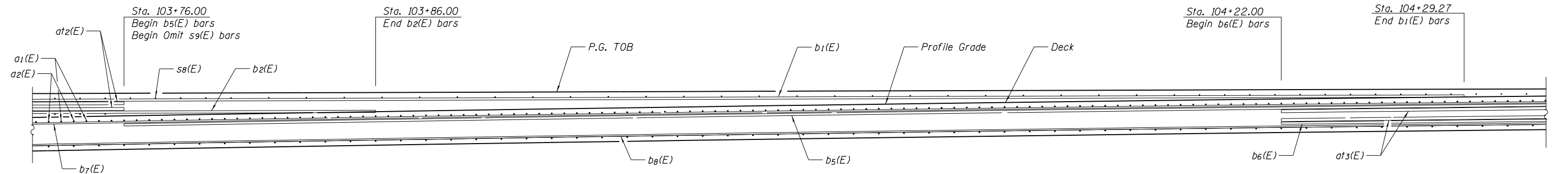

**BAR LAP DETAIL B**

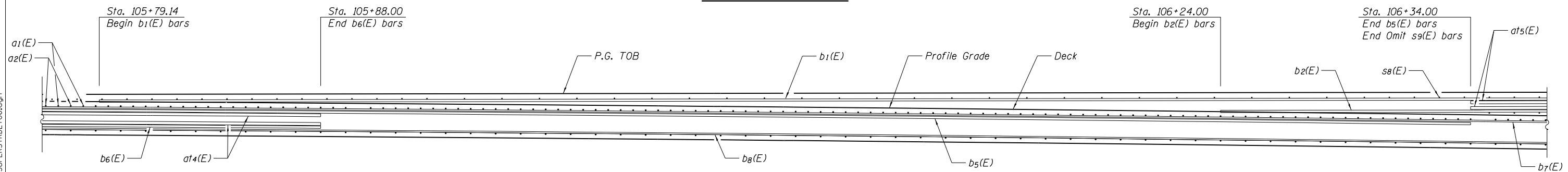

**BAR LAP DETAIL C**

FILE NAME = 045P008-XXXX-019-SUPERSTRDE106.dgn



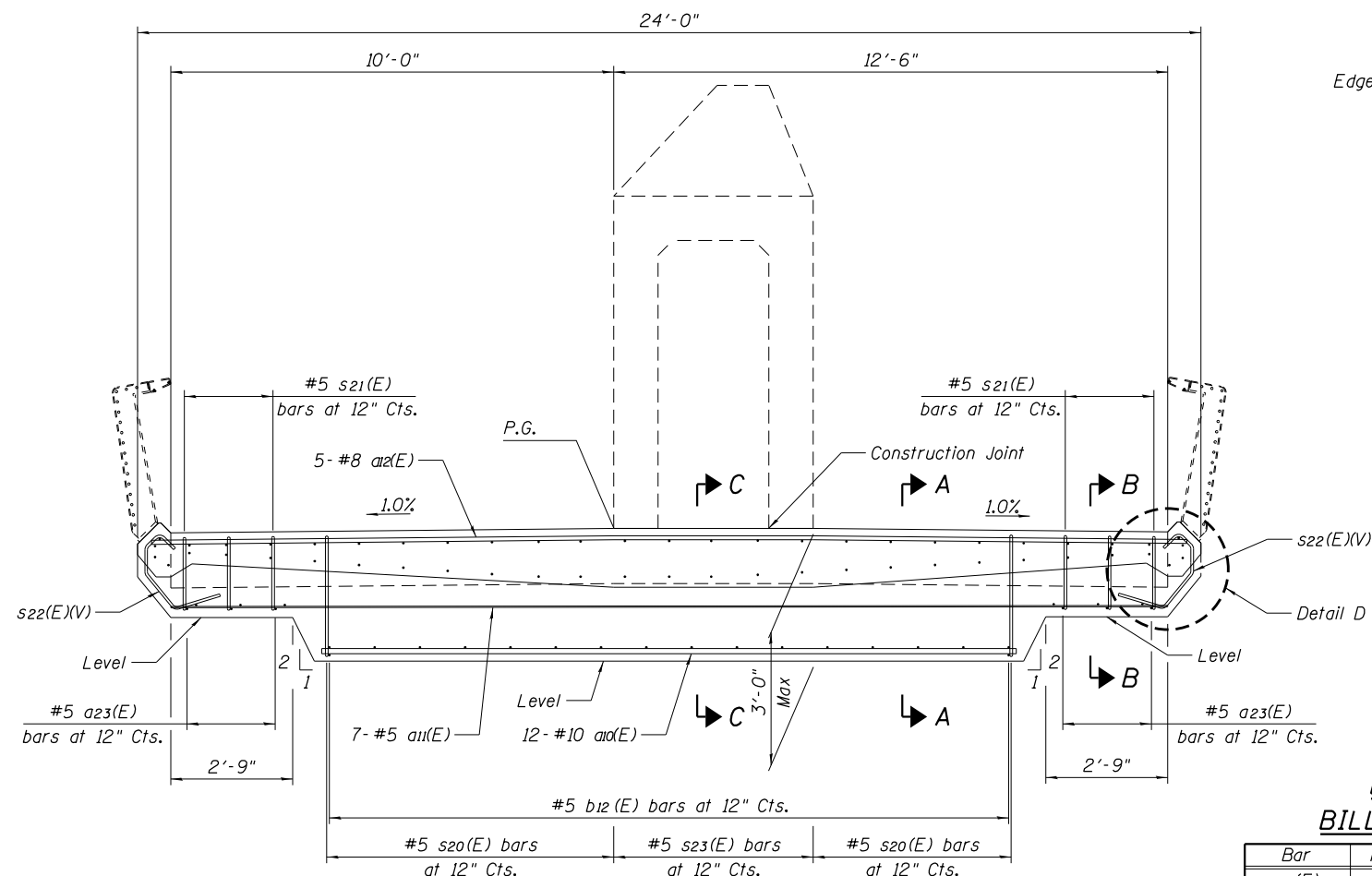

**DIAPHRAGM ELEVATION  
AT WEST ABUTMENT**  
(Looking down station)

**DIAPHRAGM  
BILL OF MATERIAL**

Bar	No.	Size	Length	Shape
a10(E)	24	#10	15'-3"	—
a11(E)	14	#5	22'-6"	—
a12(E)	10	#8	23'-4"	—
a20(E)	18	#5	29'-11"	—
a21(E)	2	#5	4'-6"	—
b12(E)	44	#5	15'-3"	—
b13(E)	32	#4	4'-6"	—
s20(E)	24	#5	16'-4"	□
s21(E)	12	#5	13'-3"	□
s22(E) Max	22	#5	3'-10"	↘
s22(E) Min	22	#5	3'-2"	↗
s23(E)	10	#5	9'-10"	□
Reinforcement Bars, Epoxy Coated			Lbs.	4,802

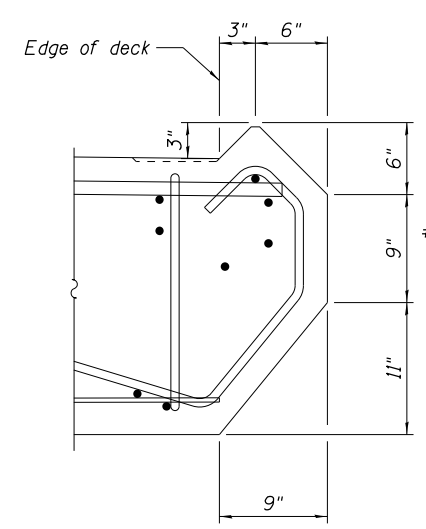
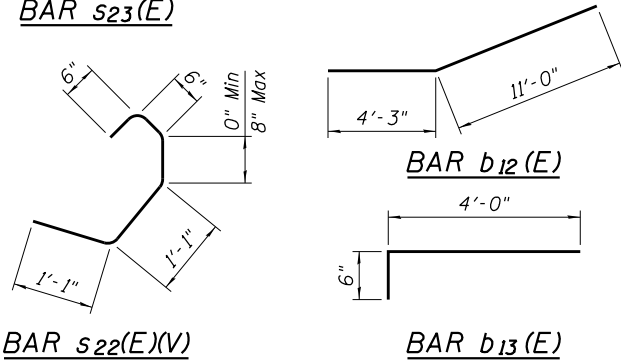
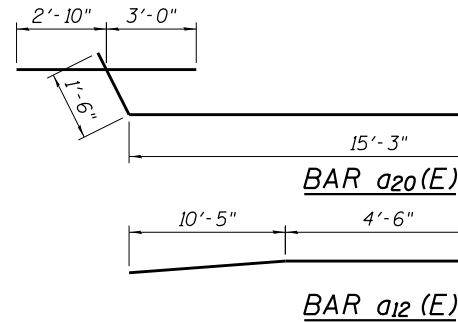
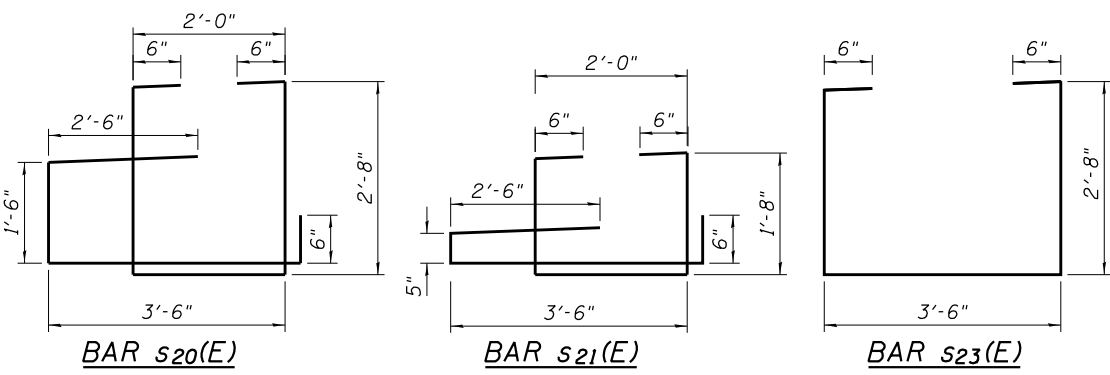

**DETAIL D**

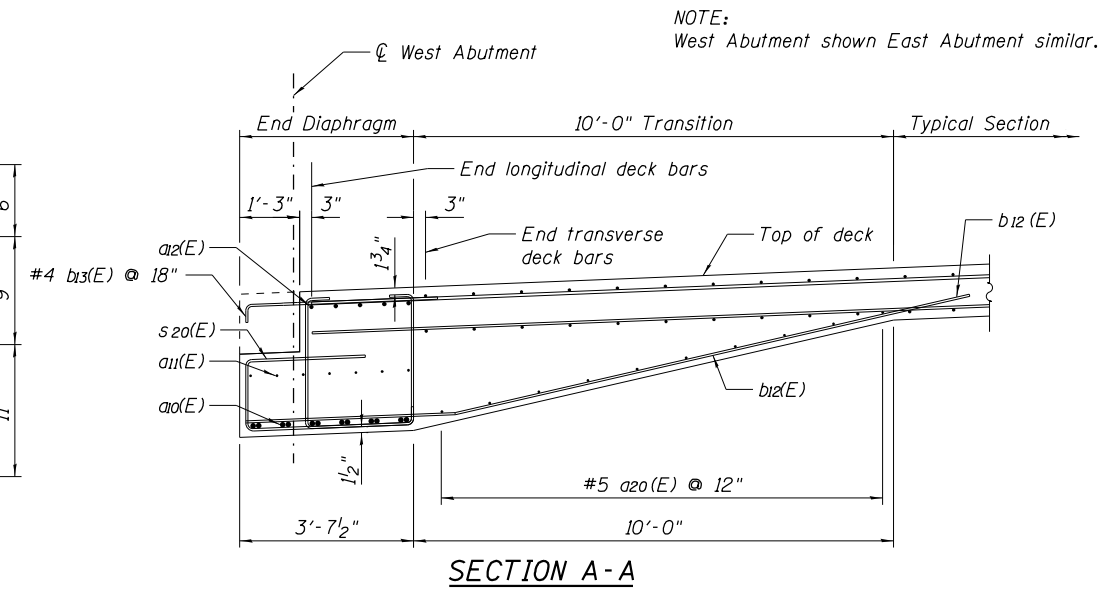

**SECTION A-A**

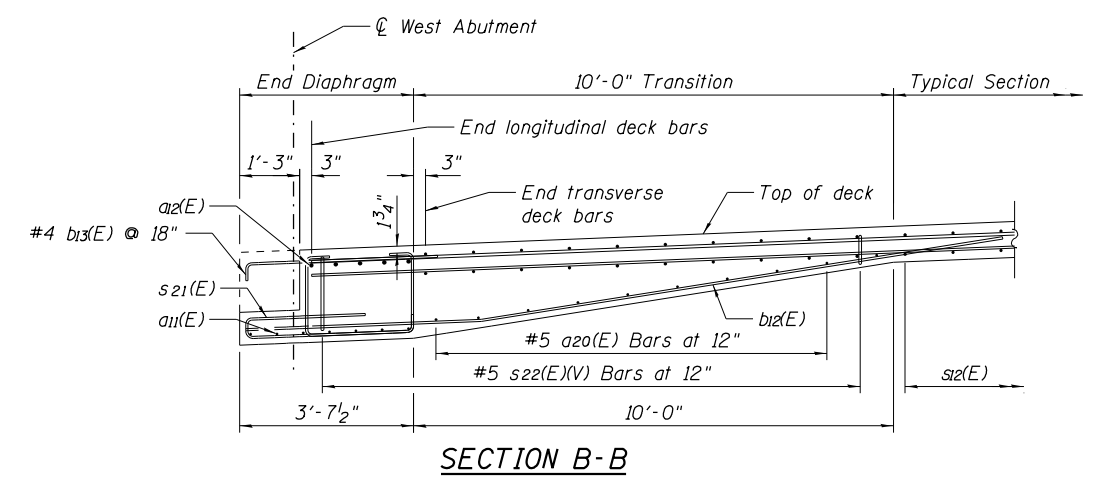

**SECTION B-B**

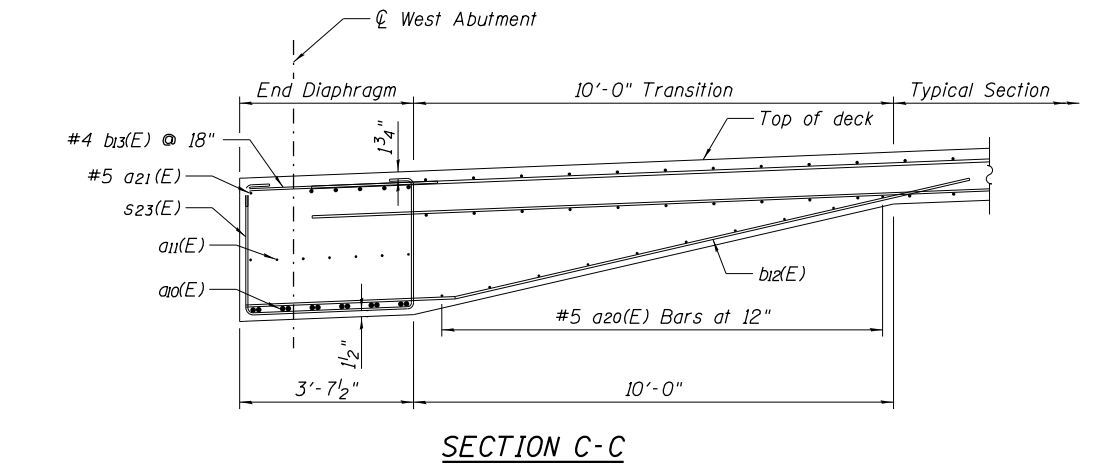

**SECTION C-C**

NOTE:  
West Abutment shown East Abutment similar.

FILE NAME = 045P008-XXXX-020-DIAPHDET01.dgn

FILE NAME = 045P008-XXXX-021-DIAPHDET02.dgn

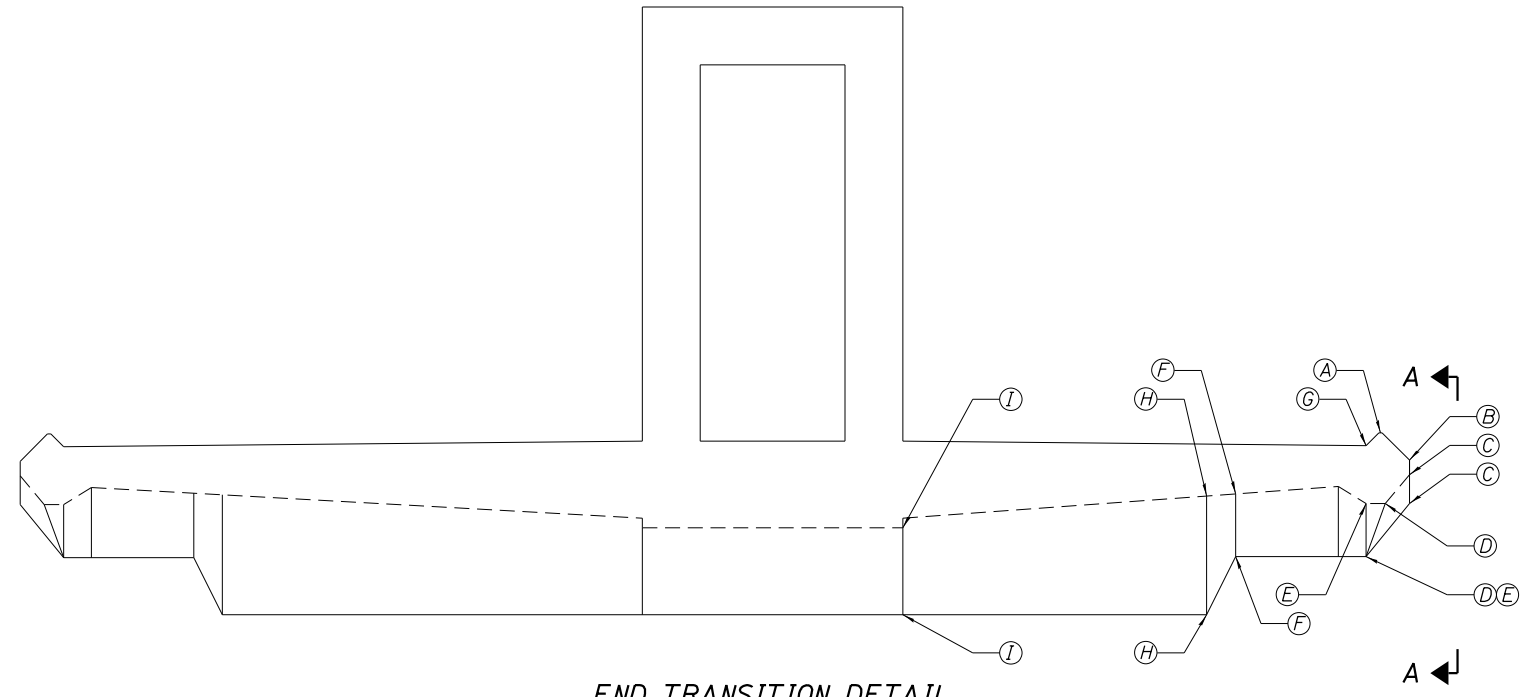

**END TRANSITION DETAIL**

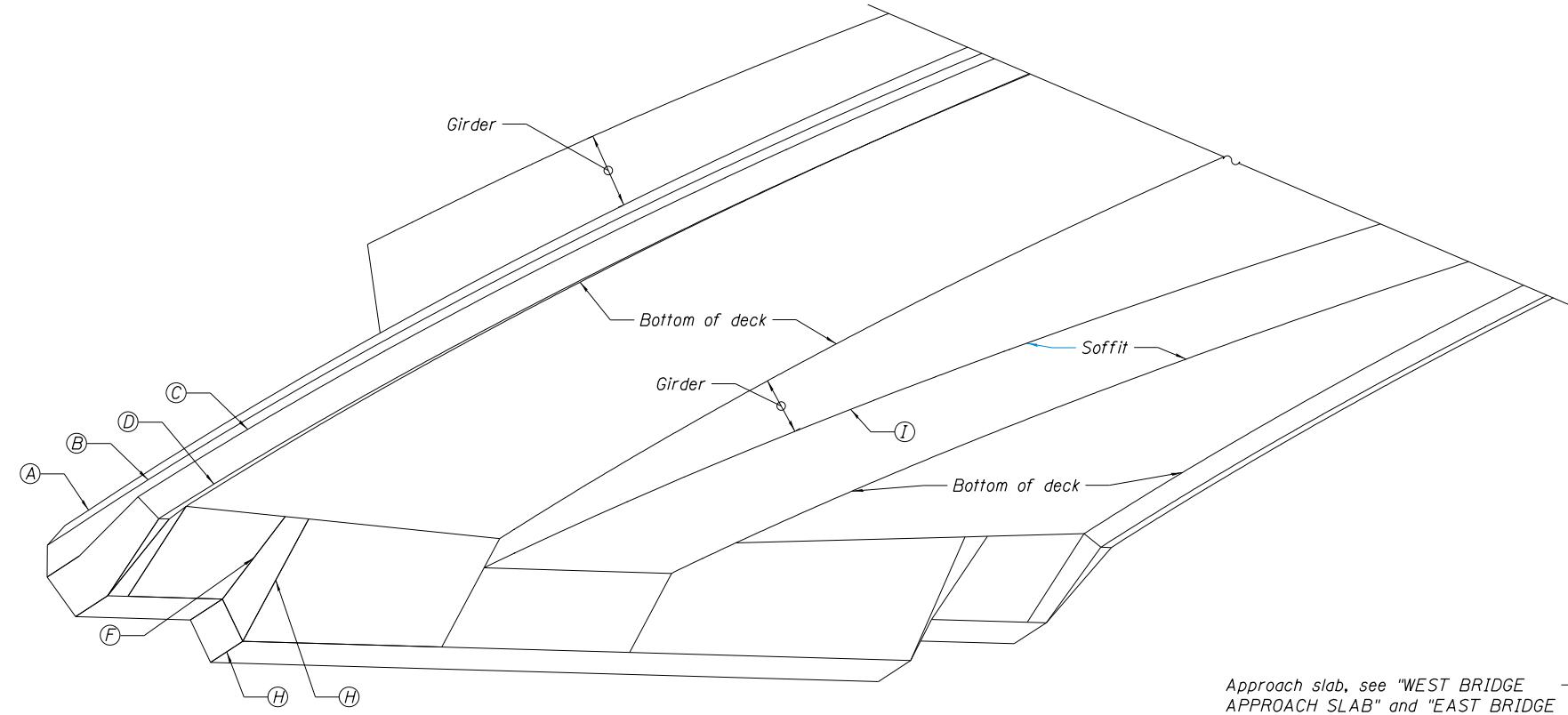

**END TRANSITION ISOMETRIC**  
West Abutment Looking West from under Bridge.  
Abutment not shown

Approach slab, see "WEST BRIDGE APPROACH SLAB" and "EAST BRIDGE APPROACH SLAB" sheet for details

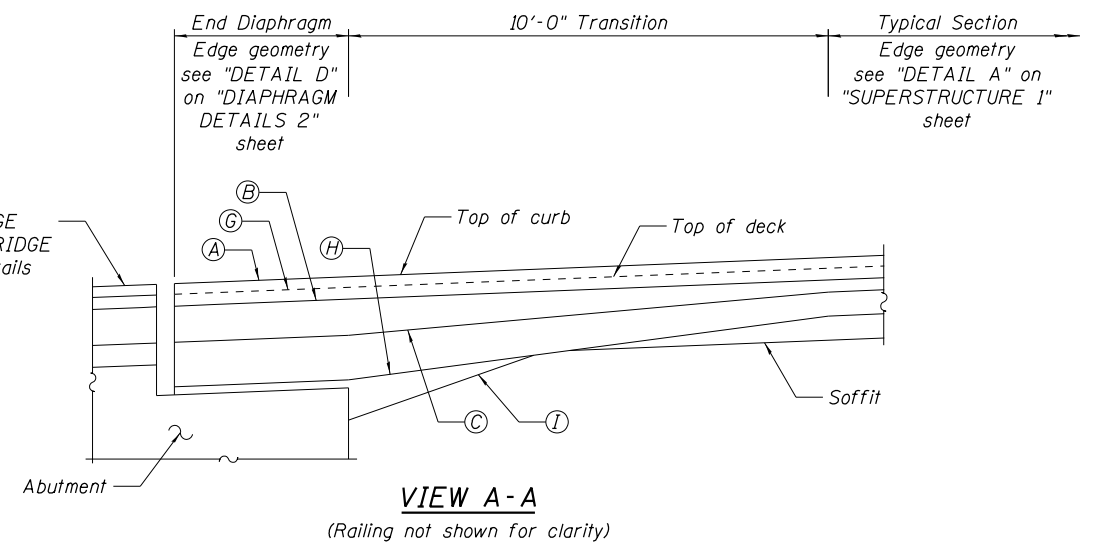

**VIEW A-A**  
(Railing not shown for clarity)

**TY-LIN INTERNATIONAL**

USER NAME = RSTONE	DESIGNED - B. Sokolowski	REVISED - -
	CHECKED - P. Frey	REVISED - -
PLOT SCALE = NO SCALE	DRAWN - I. Martin	REVISED - -
PLOT DATE = 10/19/2017	CHECKED - D. Fitzwilliam	REVISED - -

**STATE OF ILLINOIS  
DEPARTMENT OF TRANSPORTATION**

**DIAPHRAGM DETAILS 2  
STRUCTURE NO. 045-P008**

SHEET NO. S-21 OF S-69 SHEETS

F.A.U. RTE.	SECTION	COUNTY	TOTAL SHEETS	SHEET NO.
2503	16-00313-00-MS	KANE	254	182
CONTRACT NO.			61E18	

ILLINOIS FED. AID PROJECT

- NOTES:
1. For details not shown, refer to pier detail sheets.
  2. For Section A-A, B-B and C-C, see "BENT CAP DETAILS 2" sheet.
  3. Column hoops may be adjusted to avoid deck reinforcement and longitudinal superstructure reinforcement.

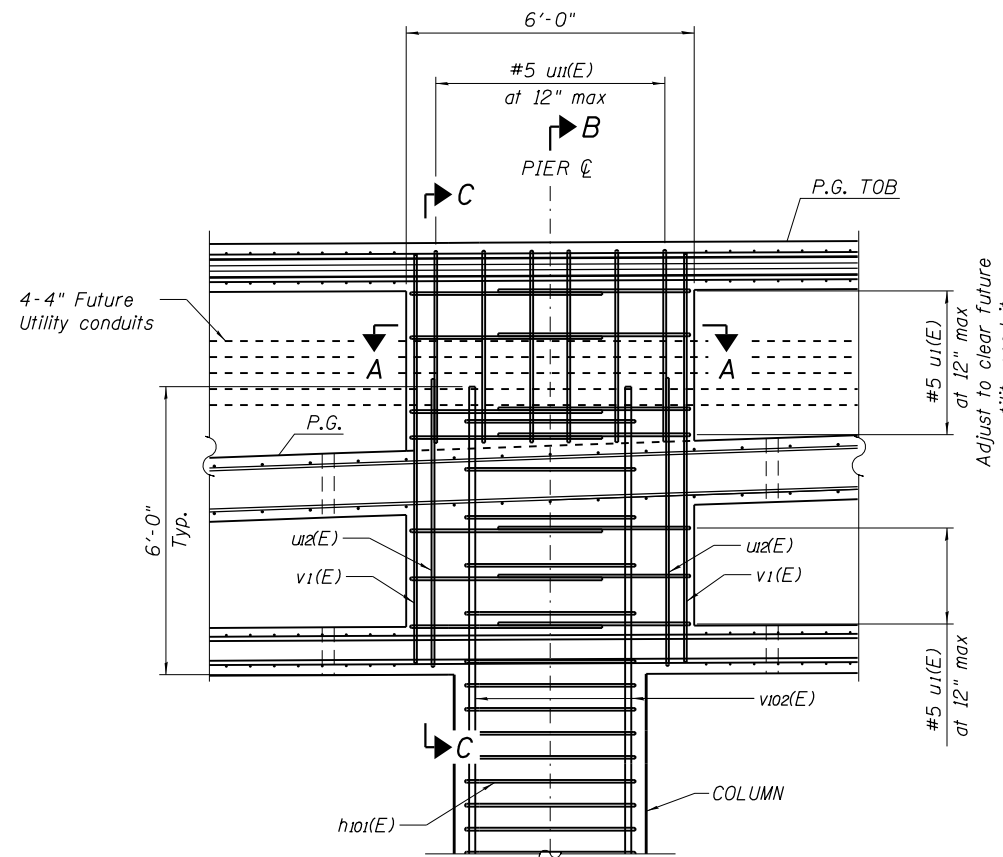

PIER 1 SECTION

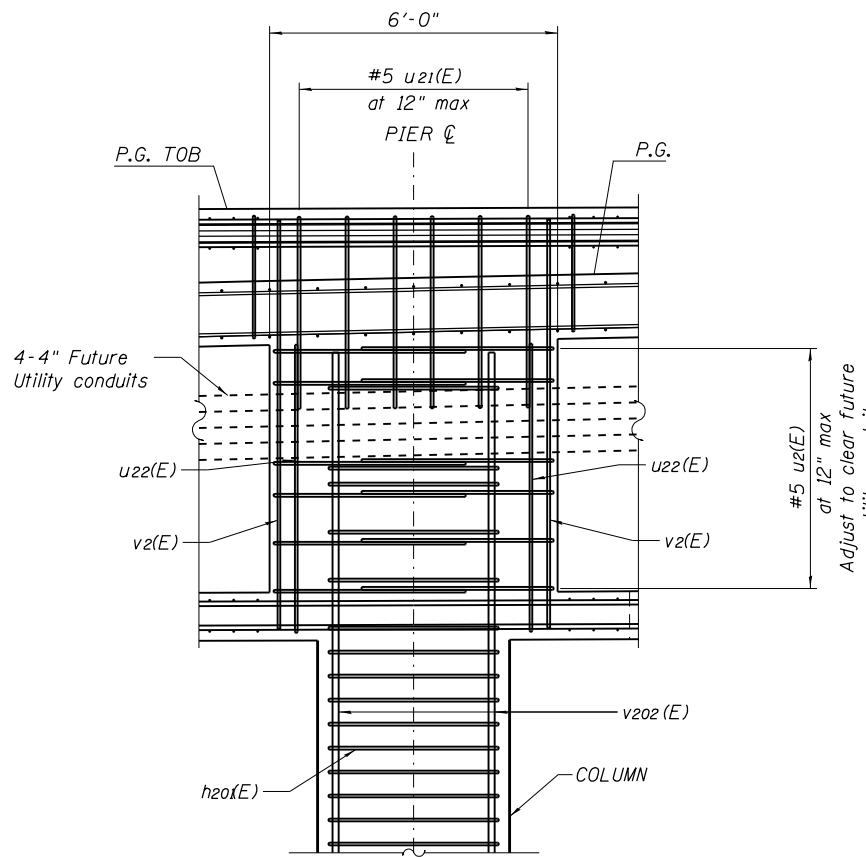

PIER 2 SECTION

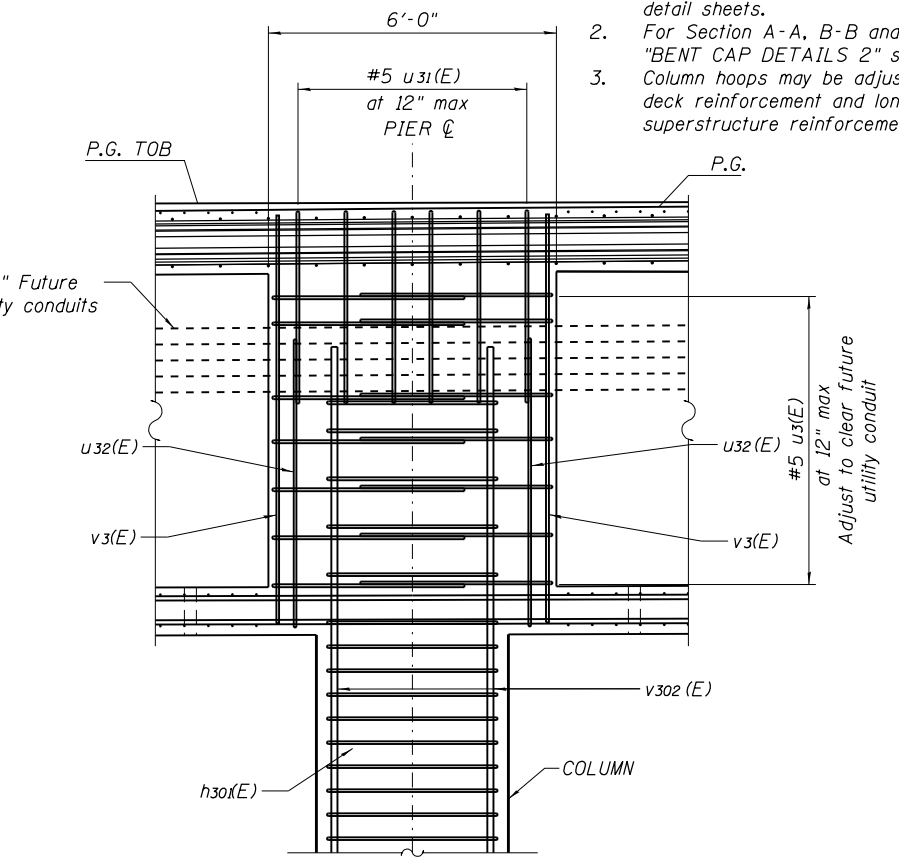

PIER 3 SECTION

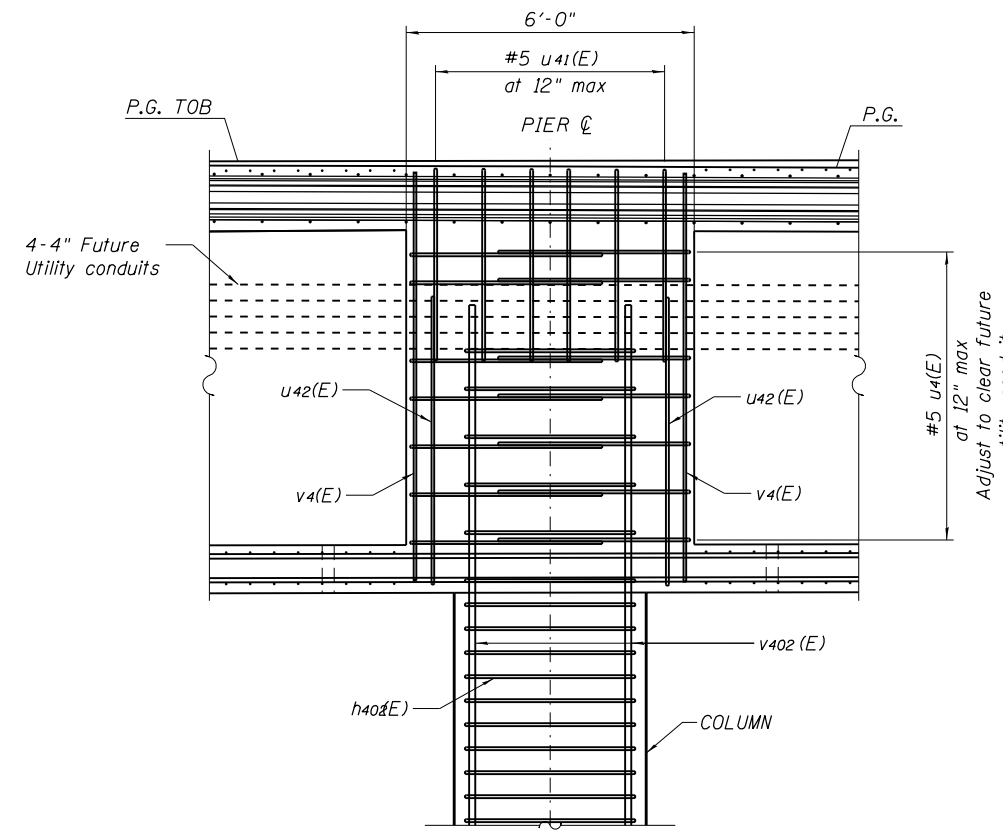

PIER 4 SECTION

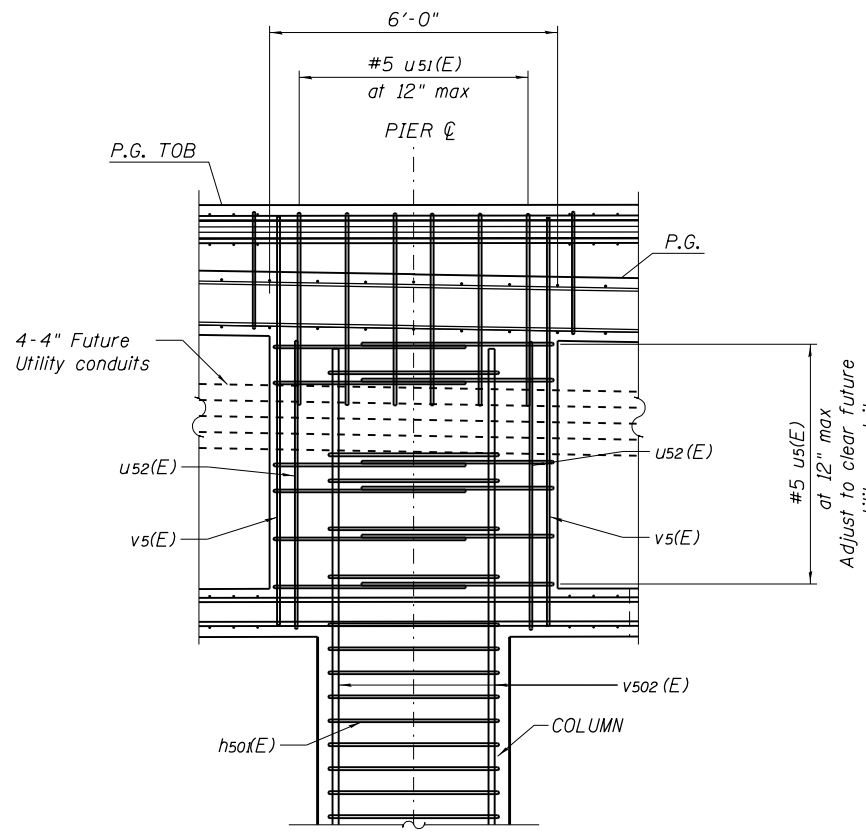

PIER 5 SECTION

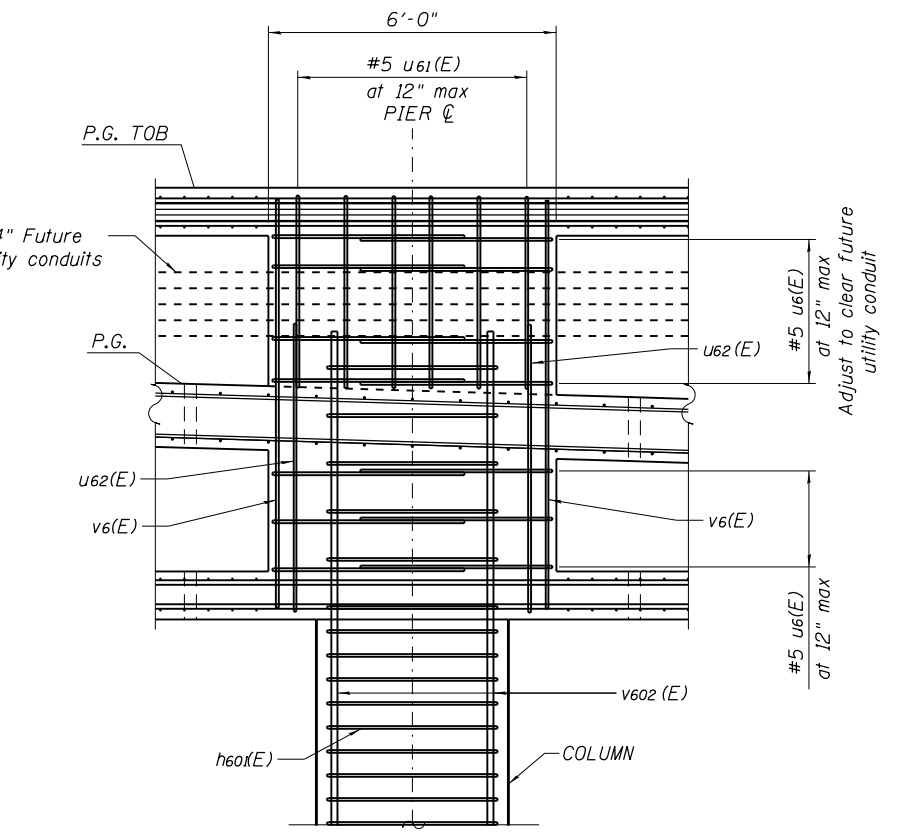

PIER 6 SECTION

FILE NAME = 045P008-XXXX-022-BENTCAPDET01.dgn

TYLIN INTERNATIONAL

USER NAME = RSTONE	DESIGNED - B. Sokolowski	REVISED - -
PLOT SCALE = NO SCALE	CHECKED - P. Frey	REVISED - -
PLOT DATE = 10/19/2017	DRAWN - I. Martin	REVISED - -
	CHECKED - D. Fitzwilliam	REVISED - -

STATE OF ILLINOIS  
DEPARTMENT OF TRANSPORTATION

BENT CAP DETAILS 1  
STRUCTURE NO. 045-P008

SHEET NO. S-22 OF S-69 SHEETS

F.A.U. RTE.	SECTION	COUNTY	TOTAL SHEETS	SHEET NO.
2503	16-00313-00-MS	KANE	254	183
CONTRACT NO.			61E18	

ILLINOIS FED. AID PROJECT

NOTE:  
1. For section callout, see "BENT CAP DETAILS No. 1".

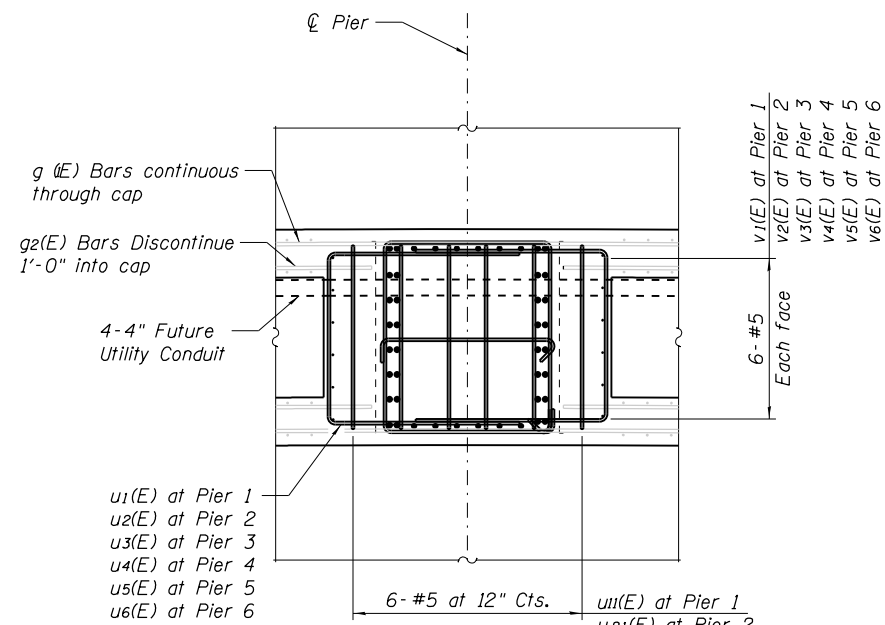

**SECTION A-A**

(Pier 1 shown Piers 2, 3, 4, 5 and 6 similar)

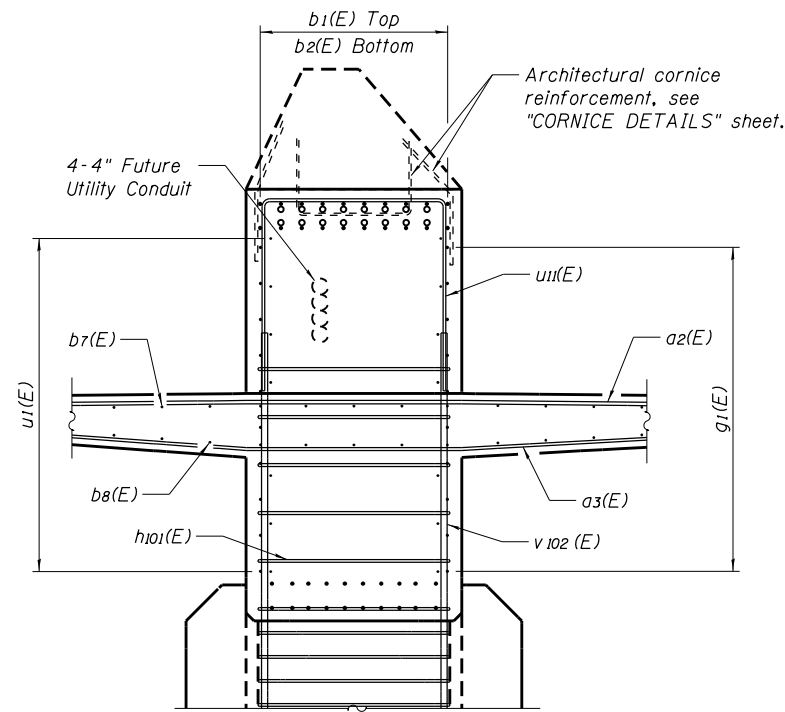

**SECTION B-B**

(Pier 1 shown Piers 2, 3, 4, 5 and 6 similar)

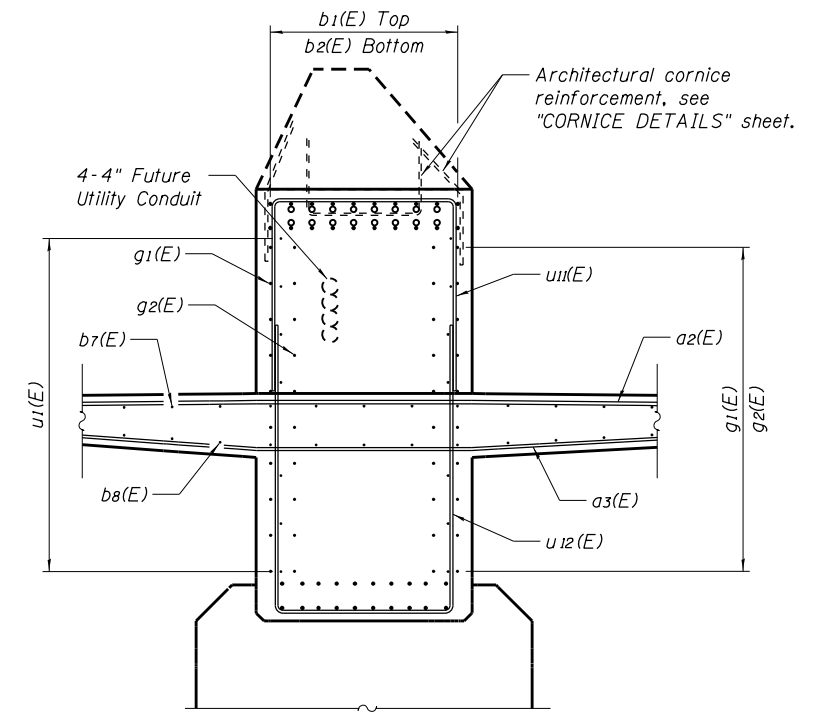

**SECTION C-C**

(Pier 1 shown Piers 2, 3, 4, 5 and 6 similar)

**SUPERSTRUCTURE  
BILL OF MATERIAL**

Bar	No.	Size	Length	Shape
v <sub>1</sub> (E)	12	#5	8'-6"	—
v <sub>2</sub> (E)	12	#5	8'-6"	—
v <sub>3</sub> (E)	12	#5	8'-6"	—
v <sub>4</sub> (E)	12	#5	8'-6"	—
v <sub>5</sub> (E)	12	#5	8'-6"	—
v <sub>6</sub> (E)	12	#5	8'-6"	—
u <sub>1</sub> (E)	14	#5	11'-6"	□
u <sub>2</sub> (E)	12	#5	11'-6"	□
u <sub>3</sub> (E)	14	#5	11'-6"	□
u <sub>4</sub> (E)	14	#5	11'-6"	□
u <sub>5</sub> (E)	12	#5	11'-6"	□
u <sub>6</sub> (E)	14	#5	11'-6"	□
u <sub>11</sub> (E)	6	#5	11'-10"	□
u <sub>21</sub> (E)	6	#5	11'-10"	□
u <sub>31</sub> (E)	6	#5	11'-10"	□
u <sub>41</sub> (E)	6	#5	11'-10"	□
u <sub>51</sub> (E)	6	#5	11'-10"	□
u <sub>61</sub> (E)	6	#5	11'-10"	□
u <sub>12</sub> (E)	2	#5	19'-10"	□
u <sub>22</sub> (E)	2	#5	19'-10"	□
u <sub>32</sub> (E)	2	#5	19'-10"	□
u <sub>42</sub> (E)	2	#5	19'-10"	□
u <sub>52</sub> (E)	2	#5	19'-10"	□
u <sub>62</sub> (E)	2	#5	19'-10"	□
Reinforcement Bars, Epoxy Coated			Lbs.	2,291

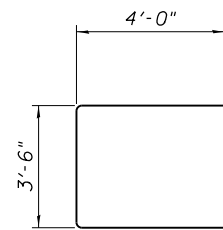

**BAR u<sub>1</sub>(E), u<sub>2</sub>(E),  
u<sub>3</sub>(E), u<sub>4</sub>(E),  
u<sub>5</sub>(E) and u<sub>6</sub>(E)**

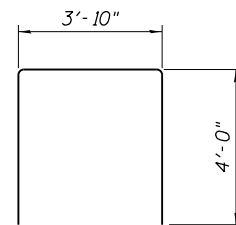

**BAR u<sub>11</sub>(E), u<sub>21</sub>(E),  
u<sub>31</sub>(E), u<sub>41</sub>(E),  
u<sub>51</sub>(E) and u<sub>61</sub>(E)**

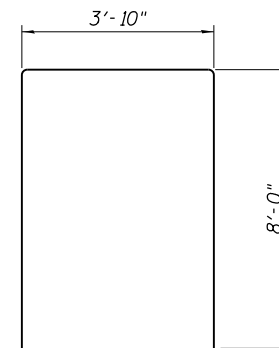

**BAR u<sub>12</sub>(E), u<sub>22</sub>(E),  
u<sub>32</sub>(E), u<sub>42</sub>(E),  
u<sub>52</sub>(E) and u<sub>62</sub>(E)**

FILE NAME = 045P008-XXXX-023-BENTCAPDET02.dgn

**TY-LIN INTERNATIONAL**

USER NAME = RSTONE	DESIGNED - B. Sokolowski	REVISED - -
	CHECKED - P. Frey	REVISED - -
PLOT SCALE = NO SCALE	DRAWN - I. Martin	REVISED - -
PLOT DATE = 10/19/2017	CHECKED - D. Fitzwilliam	REVISED - -

**STATE OF ILLINOIS  
DEPARTMENT OF TRANSPORTATION**

**BENT CAP DETAILS 2  
STRUCTURE NO. 045-P008**

SHEET NO. S-23 OF S-69 SHEETS

F.A.U. RTE.	SECTION	COUNTY	TOTAL SHEETS	SHEET NO.
2503	16-00313-00-MS	KANE	254	184
CONTRACT NO.			61E18	
ILLINOIS FED. AID PROJECT				

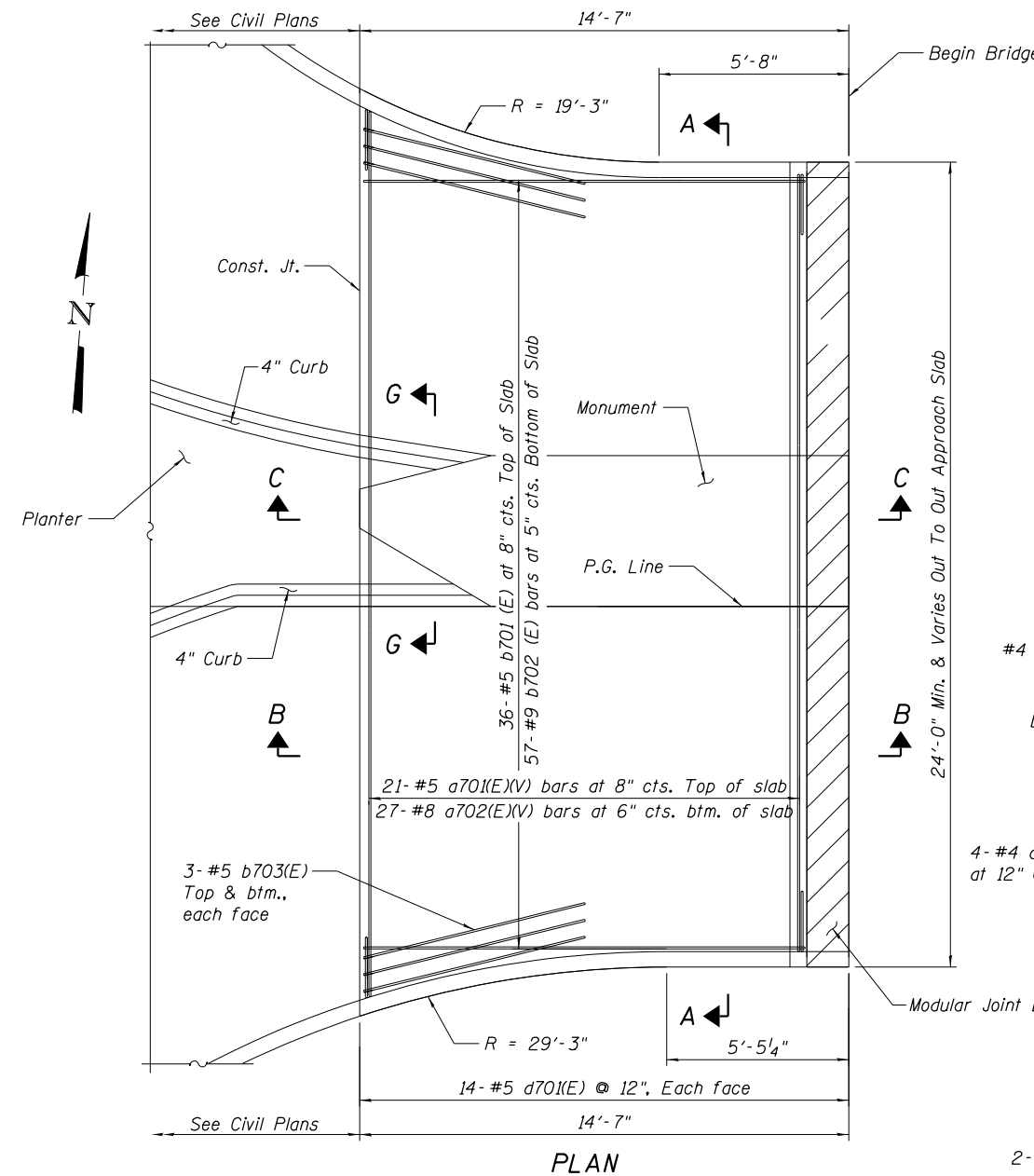

NOTES:  
 1. For modular joint blockout details, see "EXPANSION JOINT DETAILS 1" sheet.  
 2. For Monument details, see "ARCHITECTURAL DETAILS 3" sheet.

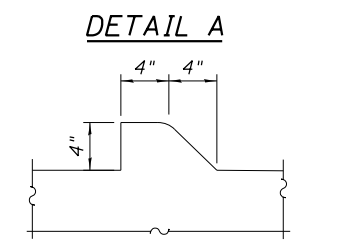
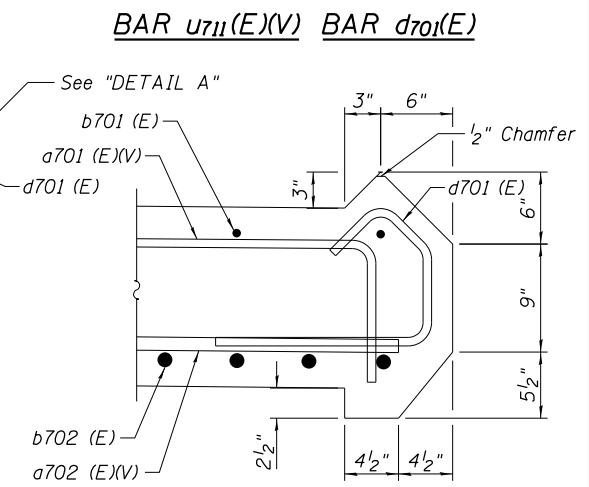
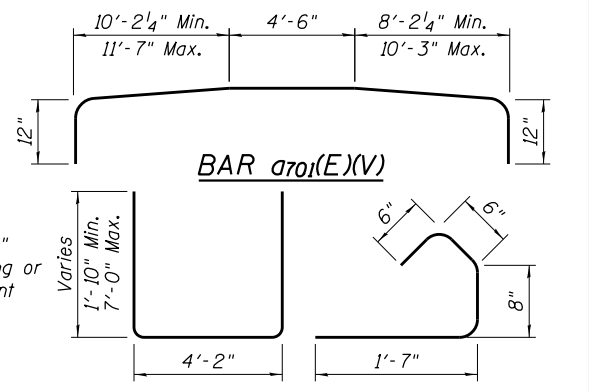
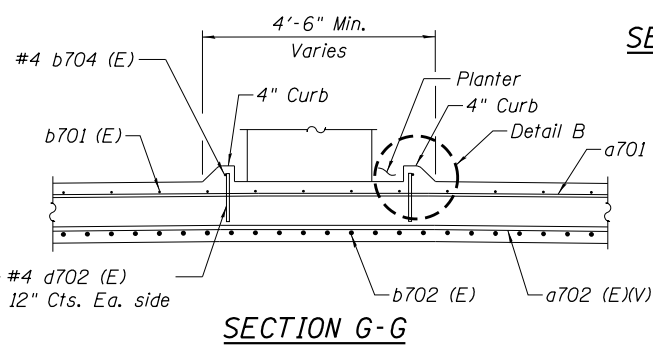
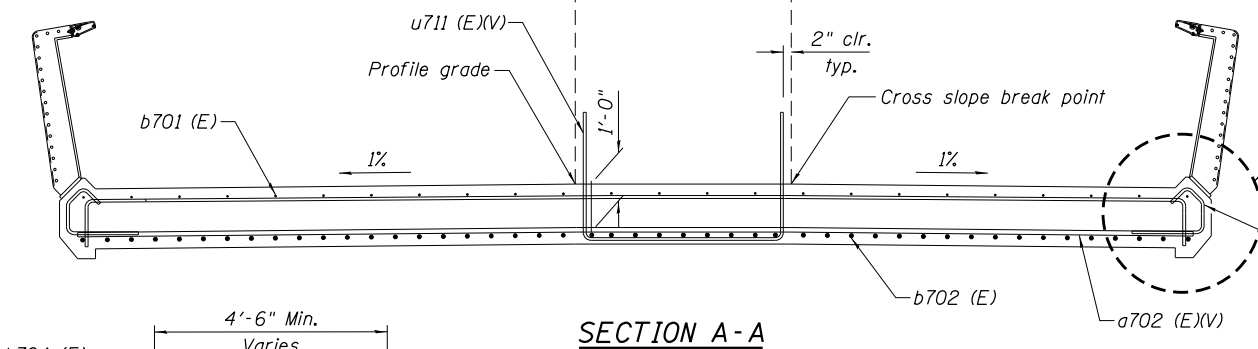

**WEST APPROACH SLAB**  
**BILL OF MATERIAL**

Bar	No.	Size	Length	Shape
a701(E) Min	21	#5	24'-11"	[ ]
a701(E) Max	21	#5	28'-4"	[ ]
a702(E) Min	27	#8	23'-6"	[ ]
a702(E) Max	27	#8	26'-5"	[ ]
b701(E)	36	#5	12'-10"	[ ]
b702(E)	57	#9	12'-10"	[ ]
b703(E)	12	#5	6'-0"	[ ]
b704(E)	2	#4	3'-2"	[ ]
d701(E)	28	#5	3'-3"	[ ]
d702(E)	8	#4	1'-0"	[ ]
u711(E) Min	10	#5	7'-10"	[ ]
u711(E) Max	10	#5	22'-4"	[ ]
v711(E)	2	#5	12'-10"	[ ]
v712(E) Min	6	#5	12'-9"	[ ]
v712(E) Max	6	#5	13'-1"	[ ]
v713(E)	2	#5	13'-0"	[ ]
Concrete Superstructure (Approach Slab)			Cu. Yd.	16.82
Reinforcement Bars, Epoxy Coated			Pound	5,720

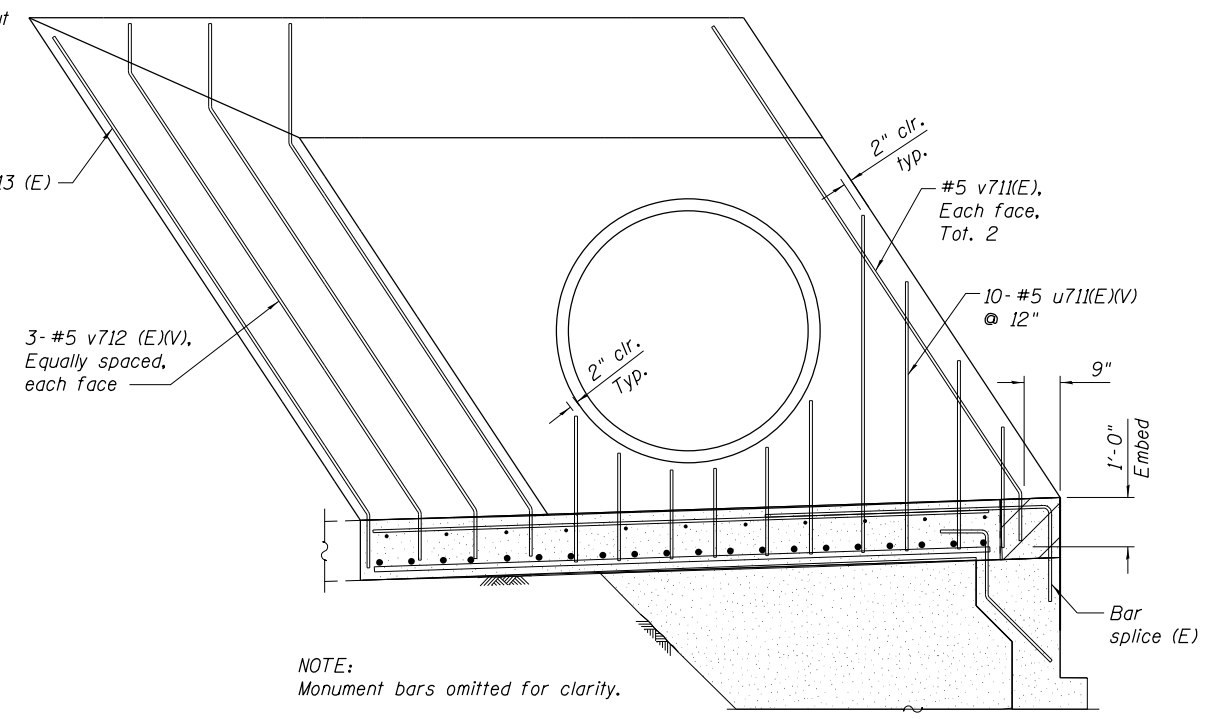
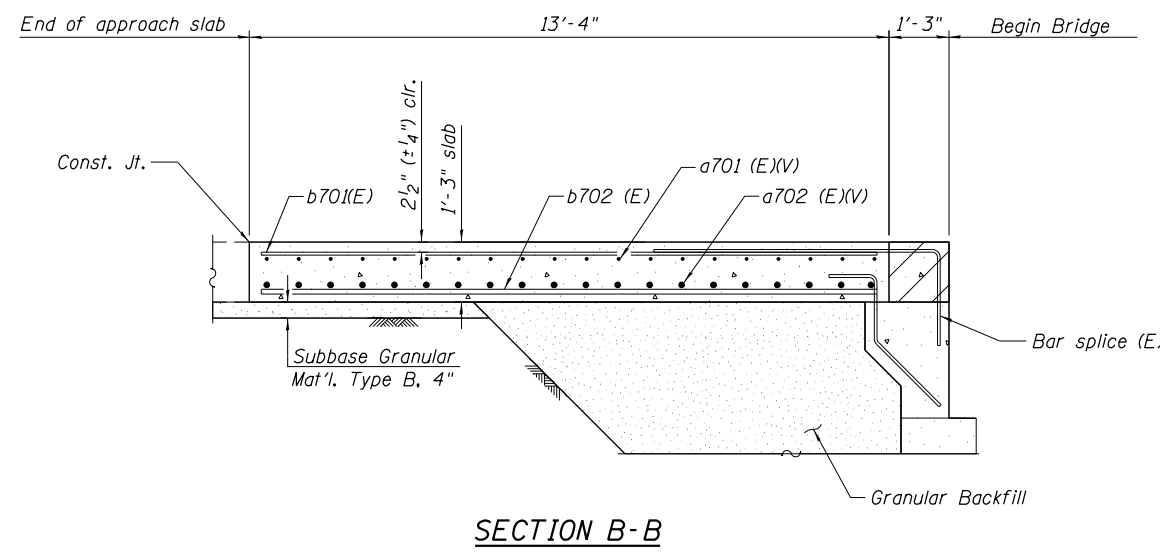

NOTE:  
 Monument bars omitted for clarity.

FILE NAME = 045P008-XXXX-024-APPSLBDE1.dgn

**TYLIN INTERNATIONAL**

USER NAME = RSTONE	DESIGNED - E. Modarres	REVISED - -
PLOT SCALE = NO SCALE	CHECKED - P. Frey	REVISED - -
PLOT DATE = 10/19/2017	DRAWN - O. Colcol	REVISED - -
	CHECKED - D. Fitzwilliam	REVISED - -

**STATE OF ILLINOIS**  
**DEPARTMENT OF TRANSPORTATION**

**WEST BRIDGE APPROACH SLAB**  
**STRUCTURE NO. 045-P008**

SHEET NO. S-24 OF S-69 SHEETS

F.A.U. RT.E.	SECTION	COUNTY	TOTAL SHEETS	SHEET NO.
2503	16-00313-00-MS	KANE	254	185
CONTRACT NO.			61E18	
ILLINOIS FED. AID PROJECT				

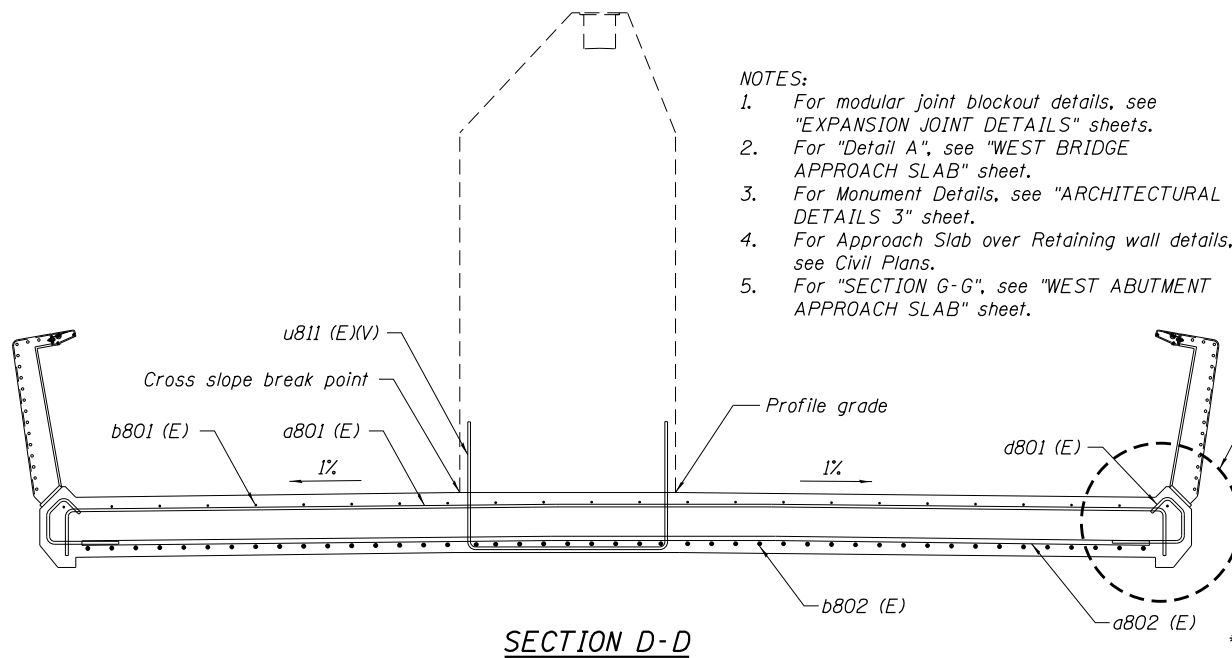
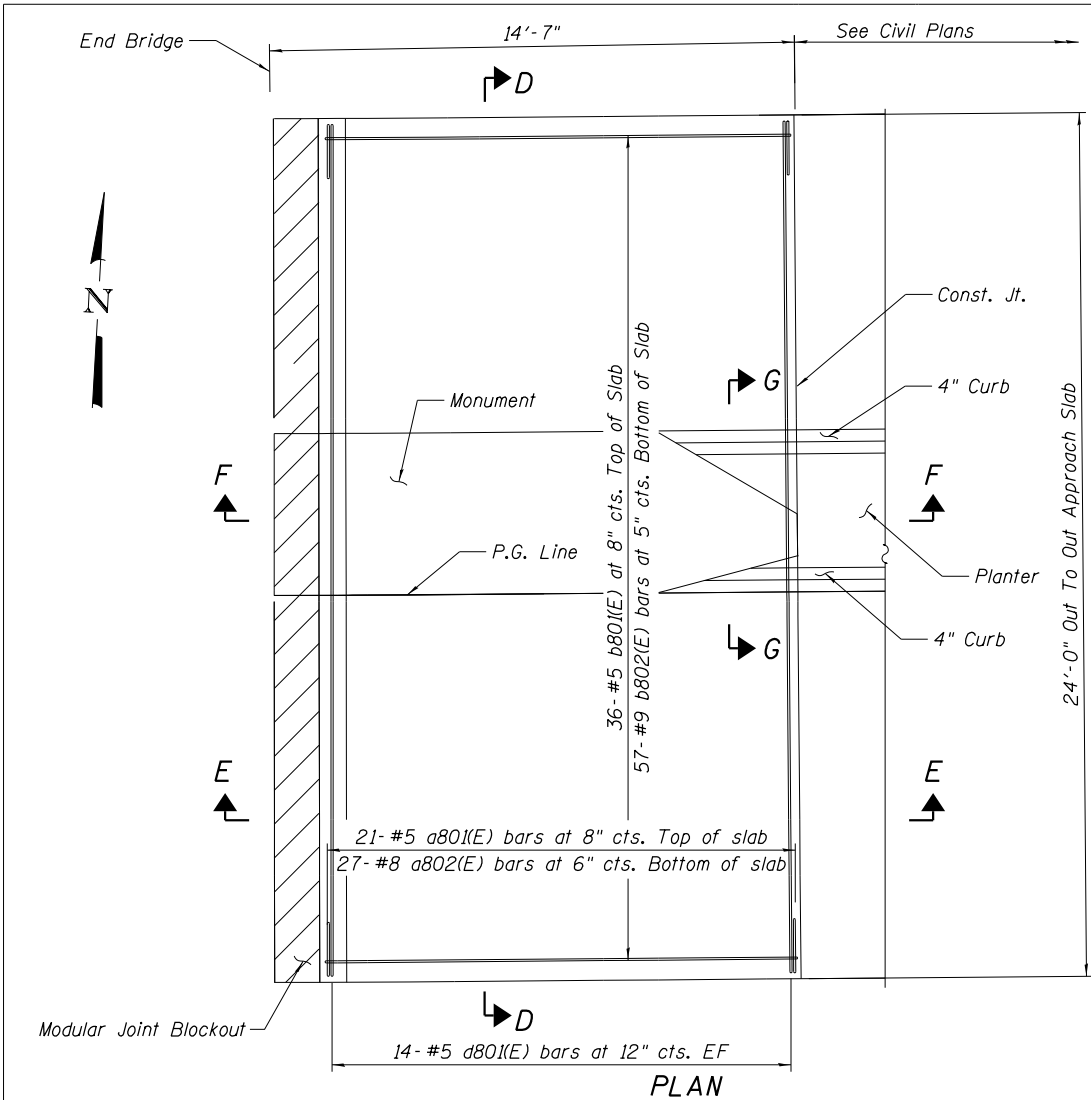

- NOTES:**
1. For modular joint blockout details, see "EXPANSION JOINT DETAILS" sheets.
  2. For "Detail A", see "WEST BRIDGE APPROACH SLAB" sheet.
  3. For Monument Details, see "ARCHITECTURAL DETAILS 3" sheet.
  4. For Approach Slab over Retaining wall details, see Civil Plans.
  5. For "SECTION G-G", see "WEST ABUTMENT APPROACH SLAB" sheet.

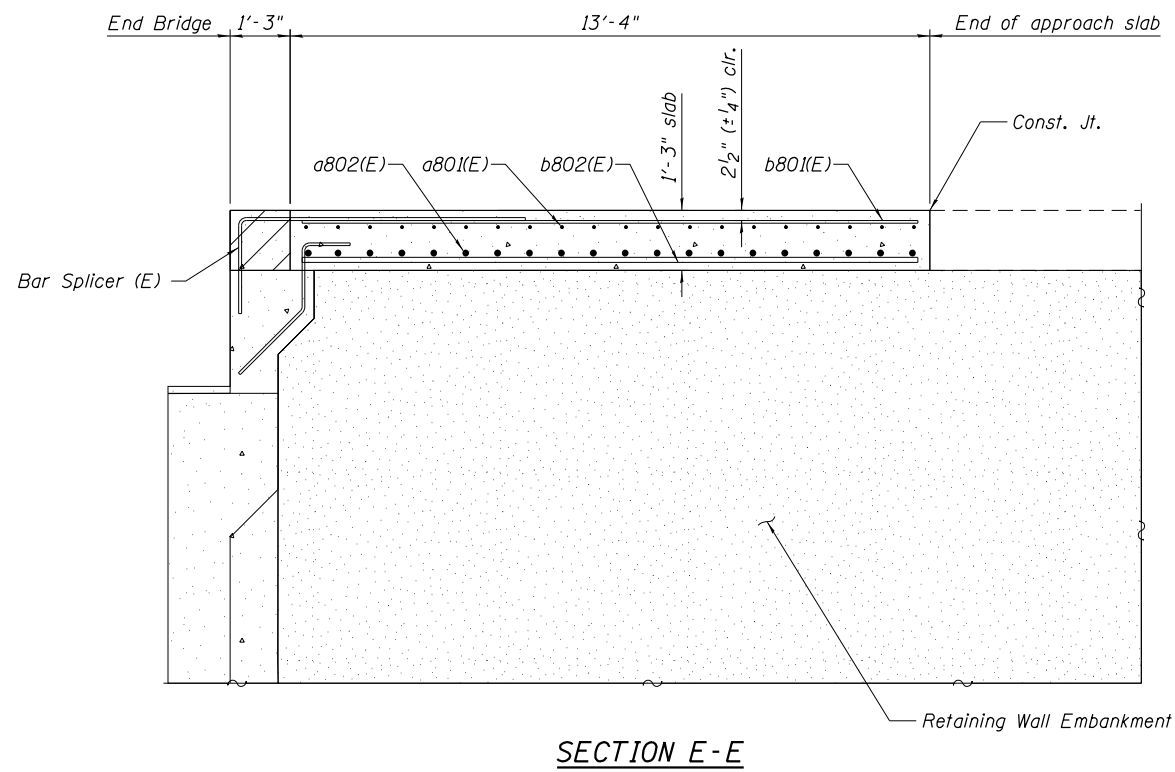
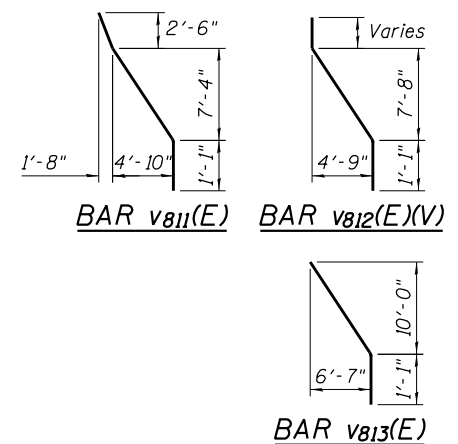
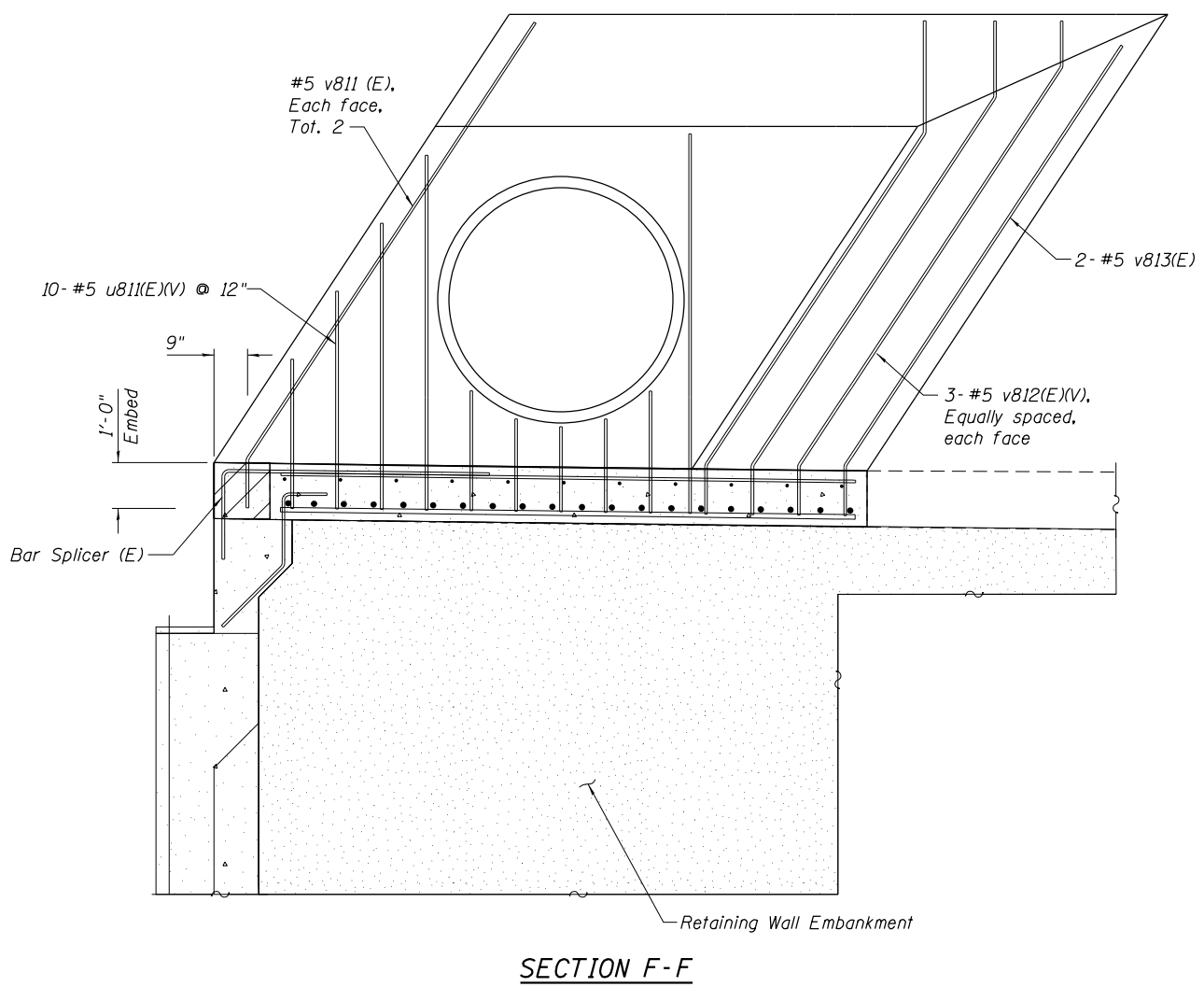
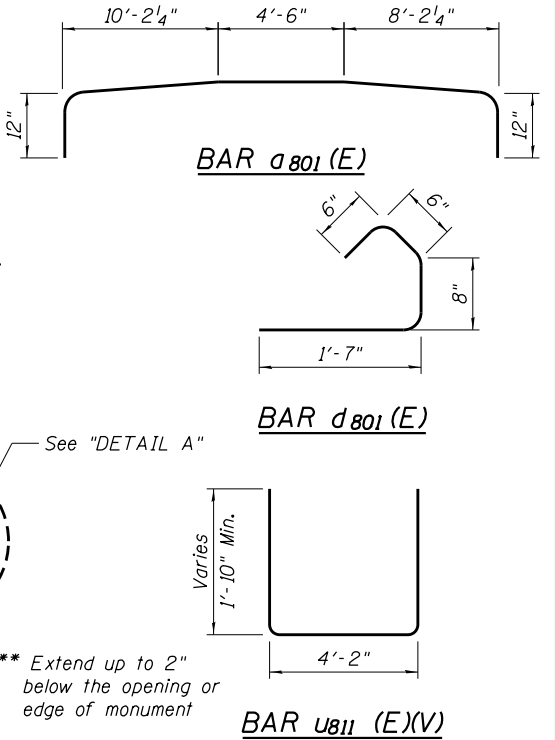

**EAST APPROACH SLAB  
BILL OF MATERIAL**

Bar	No.	Size	Length	Shape
a801 (E)	21	#5	24'-11"	⌋
a802 (E)	27	#8	23'-6"	⌋
b704 (E)	2	#4	3'-2"	⌋
b801 (E)	36	#5	12'-10"	⌋
b802 (E)	57	#9	12'-10"	⌋
d702 (E)	8	#4	1'-0"	⌋
d801 (E)	28	#5	3'-3"	⌋
u811 (E) Min	10	#5	7'-10"	⌋
u811 (E) Max	10	#5	22'-4"	⌋
v811 (E)	2	#5	12'-10"	⌋
v812 (E) Min	6	#5	13'-1"	⌋
v812 (E) Max	6	#5	12'-9"	⌋
v813 (E)	2	#5	13'-0"	⌋
Concrete Superstructure (Approach Slab)			Cu. Yd.	16.31
Reinforcement Bars, Epoxy Coated			Pound	5,567

FILE NAME = 045P008-XXXX-025-APPSLBDET2.dgn

<b>TYLIN INTERNATIONAL</b>	USER NAME = RSTONE	DESIGNED - E. Modarres	REVISED - -
	PLOT SCALE = NO SCALE	CHECKED - P. Frey	REVISED - -
	PLOT DATE = 10/19/2017	DRAWN - O. Colcol	REVISED - -
		CHECKED - D. Fitzwilliam	REVISED - -

**STATE OF ILLINOIS  
DEPARTMENT OF TRANSPORTATION**

**EAST BRIDGE APPROACH SLAB  
STRUCTURE NO. 045-P008**

SHEET NO. S-25 OF S-69 SHEETS

F.A.U. RTE.	SECTION	COUNTY	TOTAL SHEETS	SHEET NO.
2503	16-00313-00-MS	KANE	254	186
CONTRACT NO.			61E18	
ILLINOIS FED. AID PROJECT				

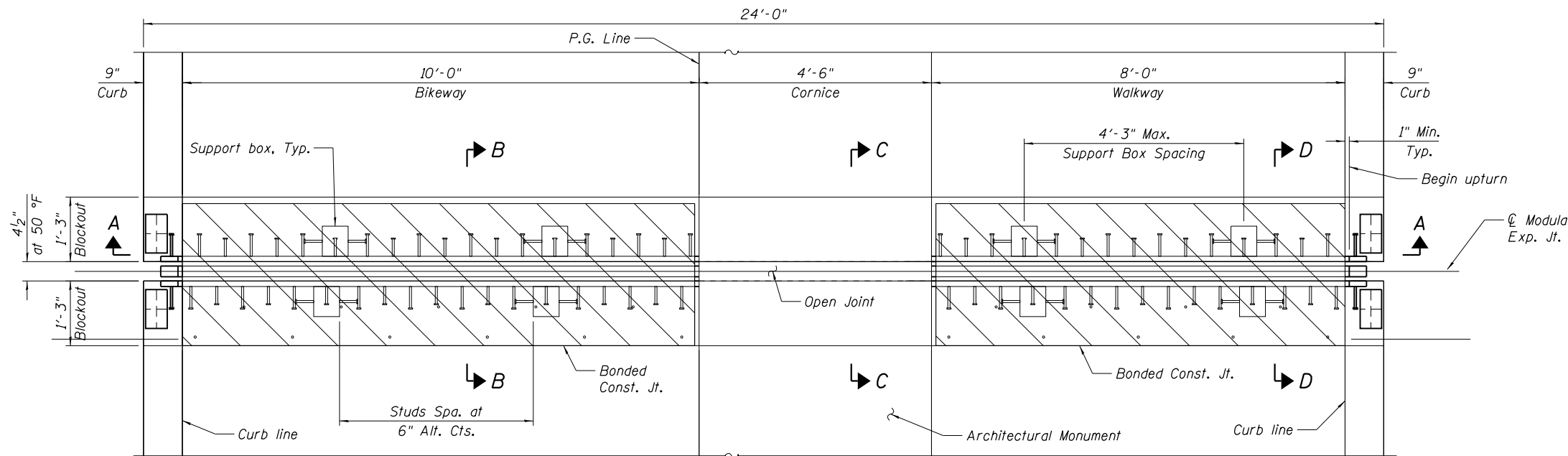

**PLAN - MODULAR EXPANSION JOINT**

(West Abutment Expansion Joint shown, East Abutment Expansion Joint similar.)

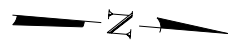

**NOTES:**

1. For "SECTION B-B", "SECTION C-C", "SECTION D-D", see "EXPANSION JOINT DETAILS 2" sheet.
2. Joint shall be fabricated and installed according to the manufacturer's recommendations and as specified in the special provisions for a modular joint system and as approved by the engineer.
3. Joint shall be fabricated to conform to the path profile and cross-slope.
4. The expansion joint assembly shall be hot dip galvanized in accordance with AASHTO M111 or M232 after fabrication.
5. Modular expansion joints shall be shipped in one piece unless noted.
6. No aluminum components shall be allowed.
7. All splices of center beams and edge beams located in the pathway shall be full penetration welds. (Upturn splices may be partial penetration welds)
8. Checkered plate assemblies as shown shall be provided for the Expansion Joint. The cost of furnishing and installing checkered plate assemblies including the checkered plate around and over the monument shall be included with Modular Expansion Joint, 6" pay item.
9. Coordinate block out dimensions, pocket locations and reinforcement bar layout with Joint Manufacturer. Block out area to be poured after expansion assemblies have been adjusted.
10. The manufacturer's recommended installation methods shall be followed.
11. The modular expansion joint system, including anchorages and support bar boxes shall be supplied by the approved chosen manufacturer.
12. The details shown are intended to be schematic. The actual components of the expansion joint system may vary from those shown. This includes, but is not limited to the number of cells, number of support bars, support bar spacing, and support bar box size. However, the total required range of expansion remains unchanged regardless of manufacturer chosen.
13. The modular expansion joint system shall accommodate 4 1/2" total longitudinal movement.
14. Coordinate joint upturns with the Railing Connection.

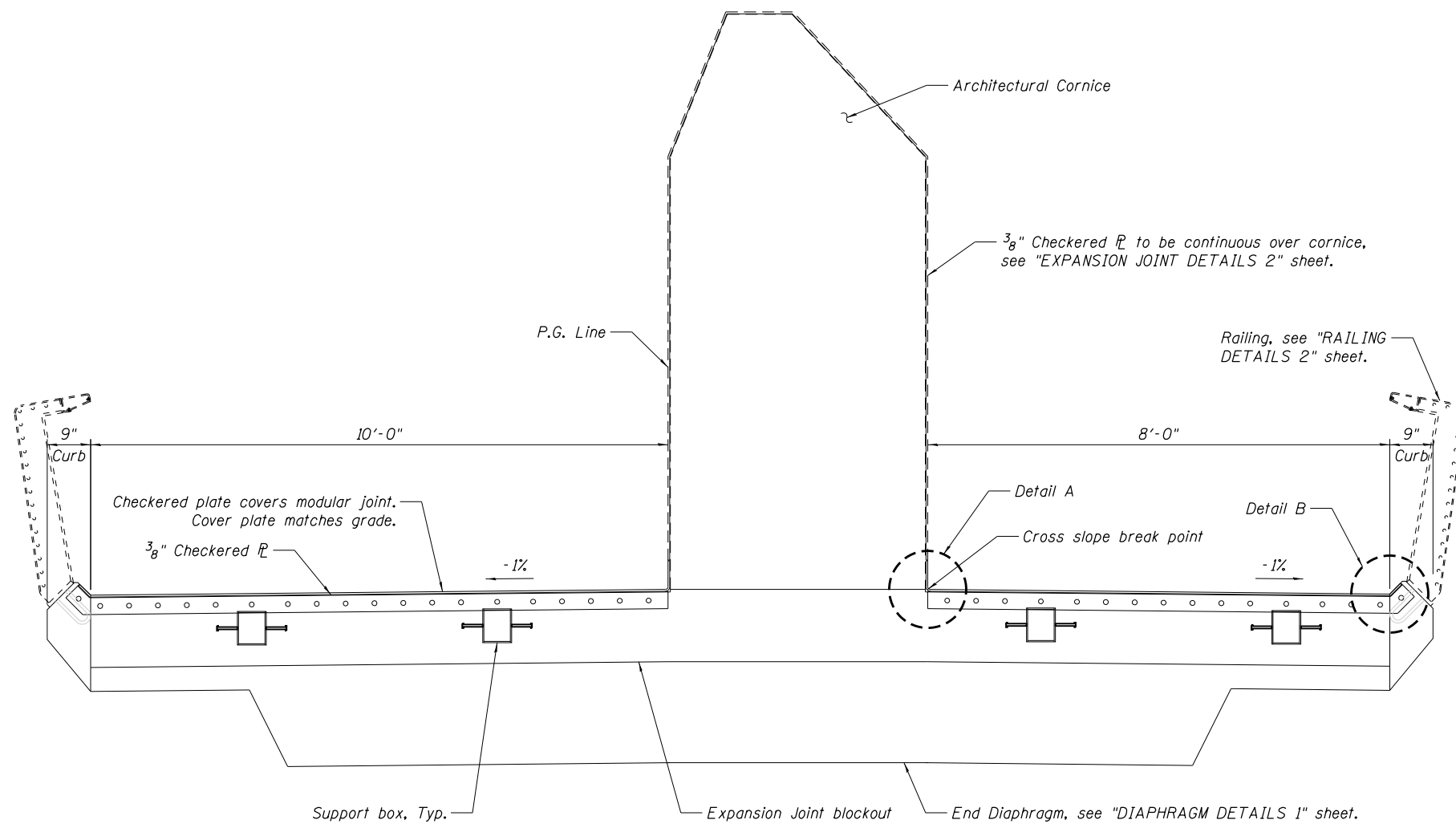

**SECTION A-A**

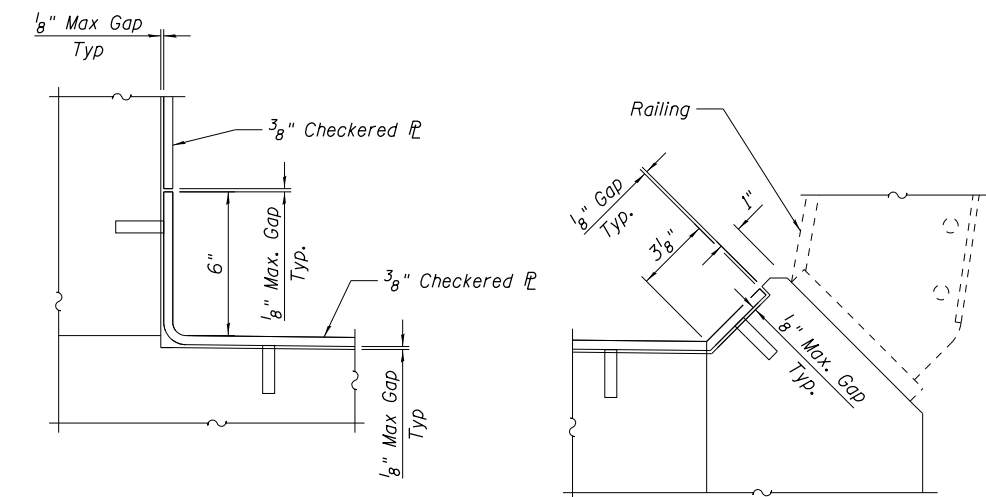

**DETAIL A**

**DETAIL B**

**BILL OF MATERIAL**

ITEM	UNIT	TOTAL
Modular Expansion Joint 6"	Foot	39'-0"

FILE NAME = 045P008-XXXX-026-EXPJTDET1.dgn

**TY-LIN INTERNATIONAL**

USER NAME = RSTONE	DESIGNED - E. Modarres	REVISED - -
	CHECKED - P. Frey	REVISED - -
PLOT SCALE = NO SCALE	DRAWN - I. Martin	REVISED - -
PLOT DATE = 10/19/2017	CHECKED - D. Fitzwilliam	REVISED - -

**STATE OF ILLINOIS  
DEPARTMENT OF TRANSPORTATION**

**EXPANSION JOINT DETAILS 1  
STRUCTURE NO. 045-P008**

SHEET NO. S-26 OF S-69 SHEETS

F.A.U. RT.E.	SECTION	COUNTY	TOTAL SHEETS	SHEET NO.
2503	16-00313-00-MS	KANE	254	187
CONTRACT NO.			61E18	

ILLINOIS FED. AID PROJECT

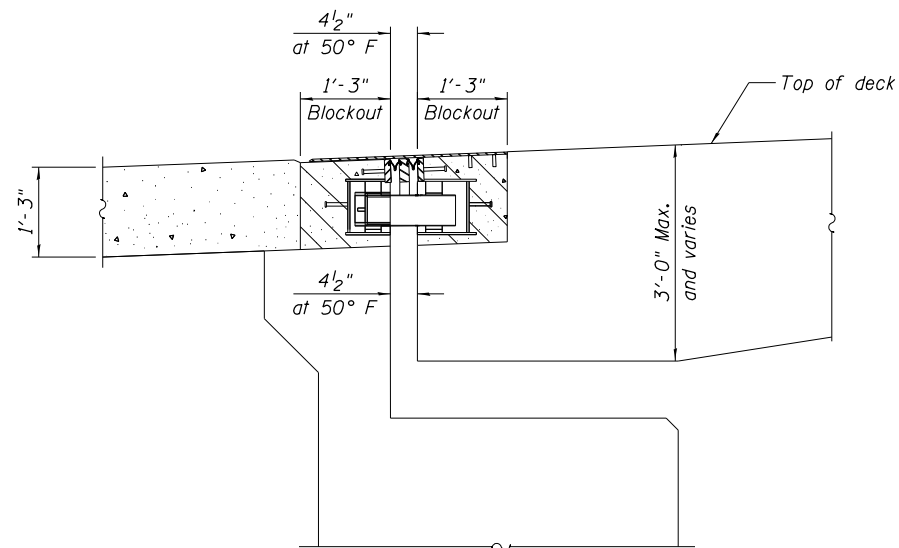

SECTION B-B

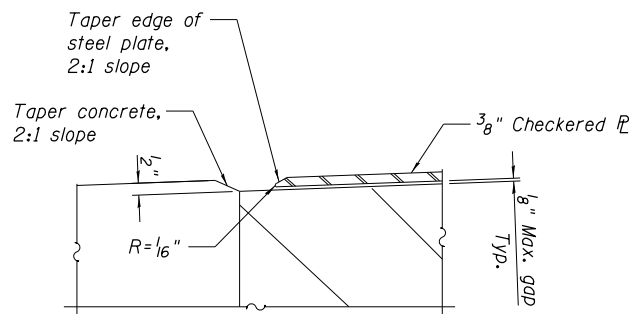

DETAIL C

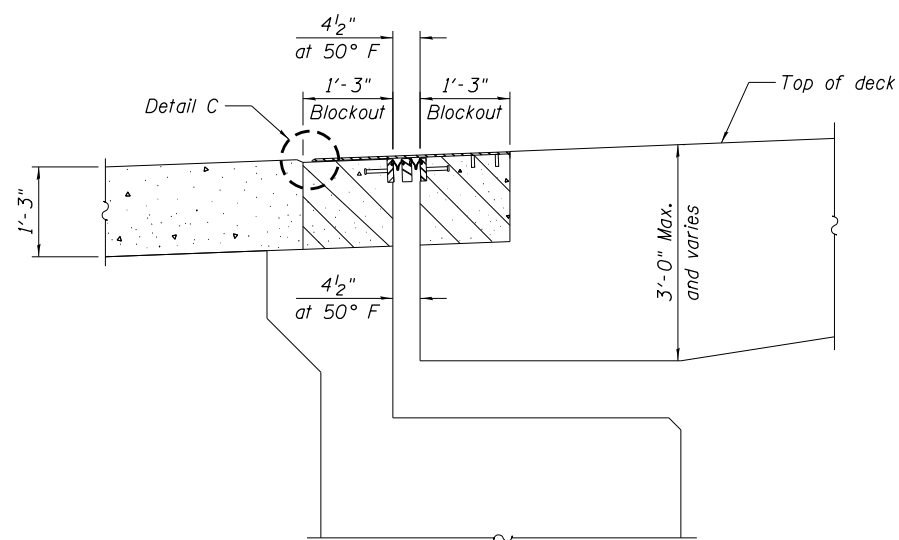

SECTION C-C

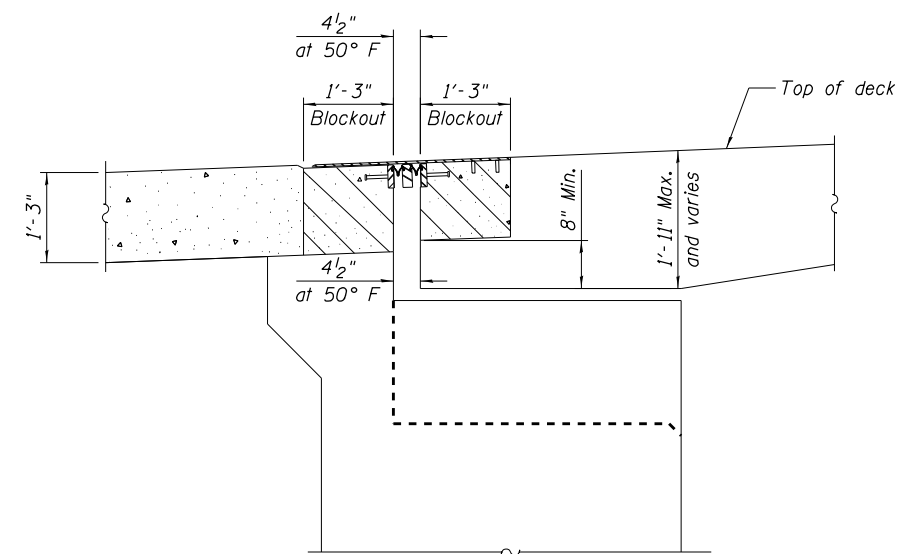

SECTION D-D

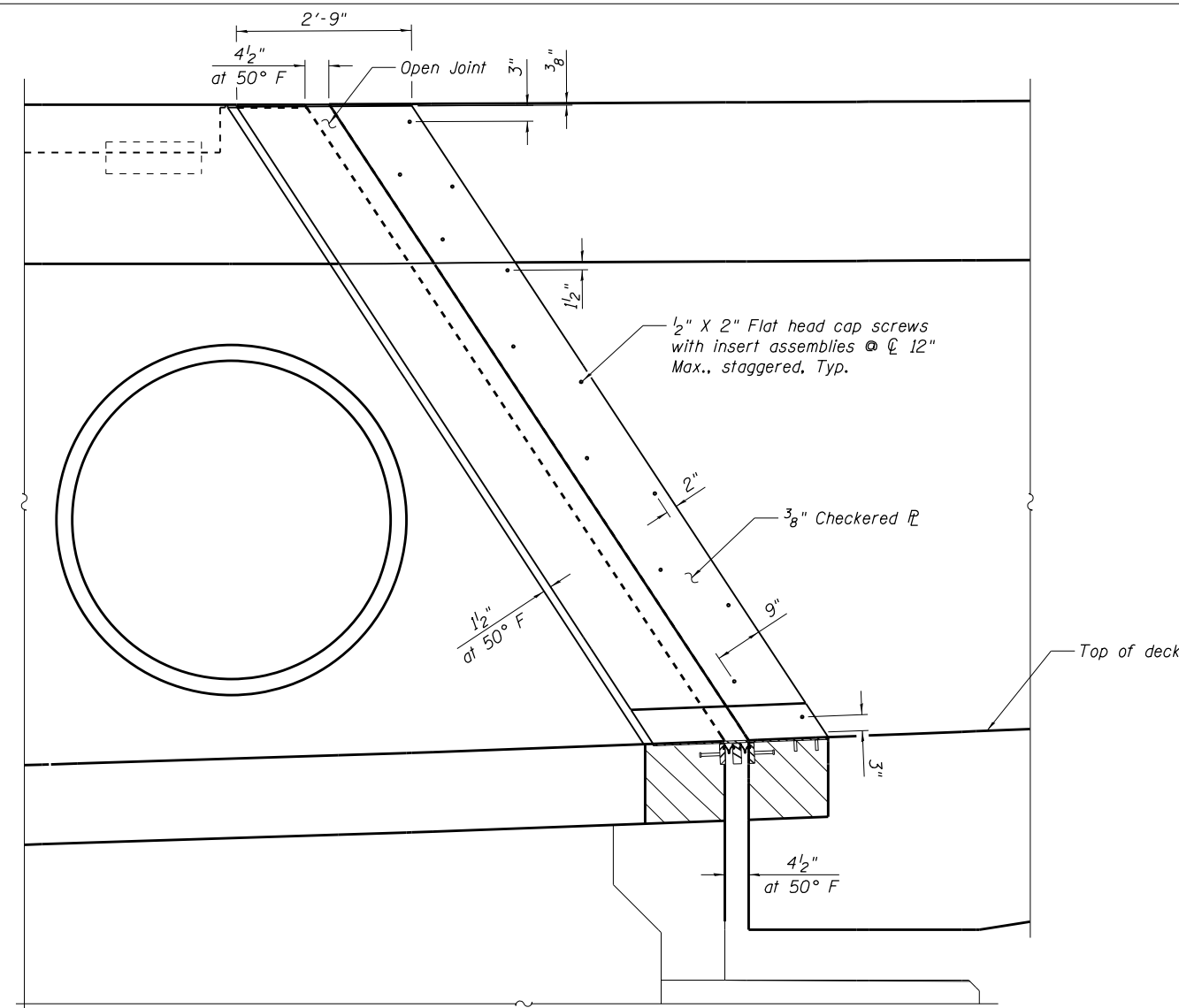

CORNICE ELEVATION - MODULAR EXPANSION JOINT  
(West Abutment Expansion Joint shown, East Abutment Expansion Joint similar.)  
(All dimensions are @ 50°F)

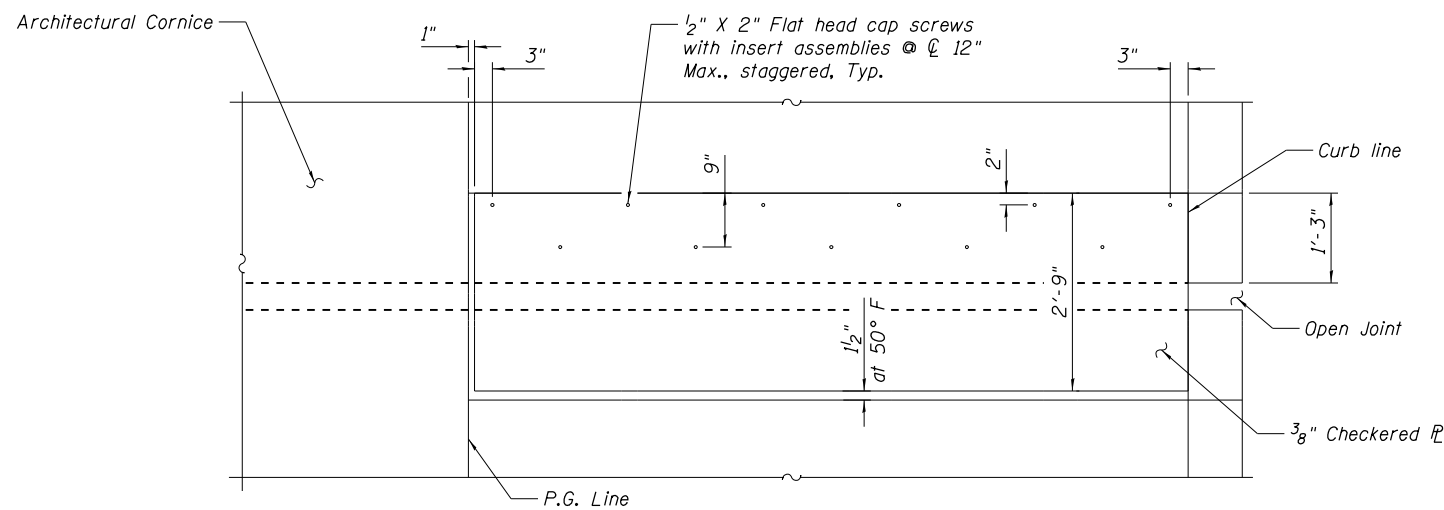

PLAN - MODULAR EXPANSION JOINT COVER PLATE  
(West Abutment Expansion Joint shown, East Abutment Expansion Joint similar)

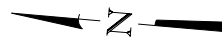

FILE NAME = 045P008-XXXX-027-EXPJTDET2.dgn

TYLIN INTERNATIONAL

USER NAME = RSTONE	DESIGNED - E. Modarres	REVISED - -
PLOT SCALE = NO SCALE	CHECKED - P. Frey	REVISED - -
PLOT DATE = 10/19/2017	DRAWN - I. Martin	REVISED - -
	CHECKED - D. Fitzwilliam	REVISED - -

STATE OF ILLINOIS  
DEPARTMENT OF TRANSPORTATION

EXPANSION JOINT DETAILS 2  
STRUCTURE NO. 045-P008

SHEET NO. S-27 OF S-69 SHEETS

F.A.U. RTE.	SECTION	COUNTY	TOTAL SHEETS	SHEET NO.
2503	16-00313-00-MS	KANE	254	188
CONTRACT NO.			61E18	

ILLINOIS FED. AID PROJECT



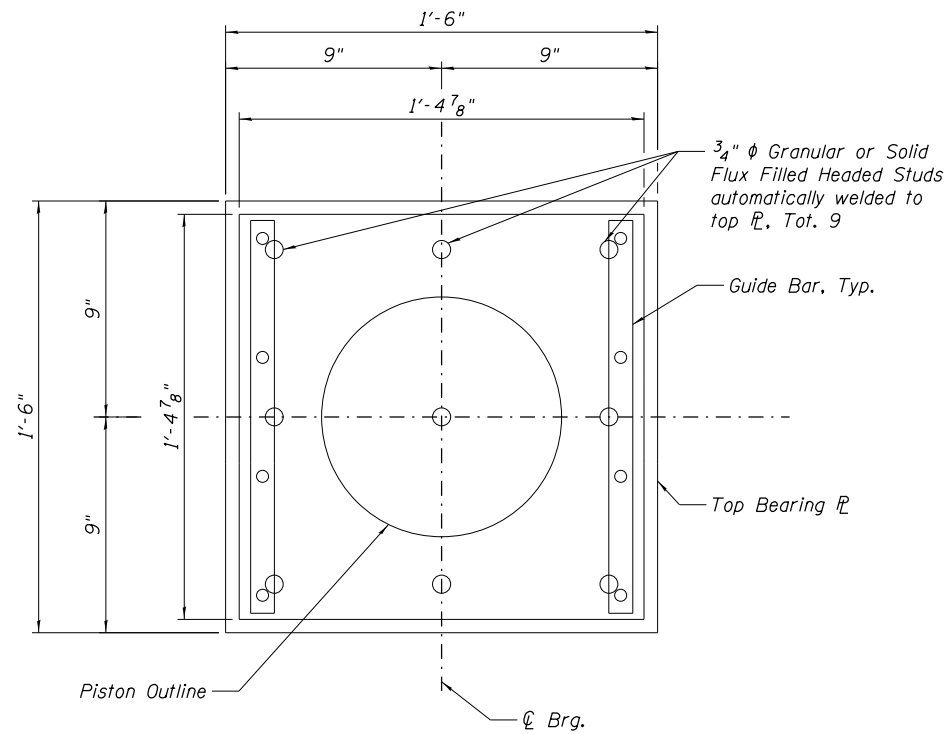

**TOP BEARING PLATE AND BASE PISTON PLAN**

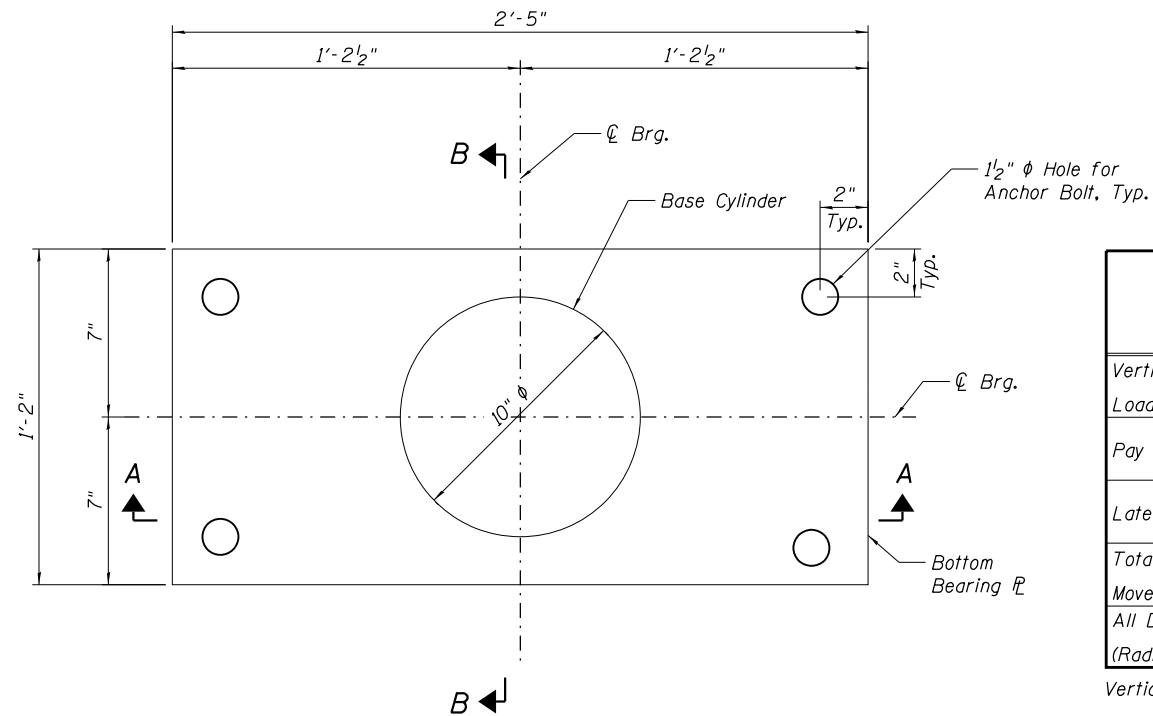

**BOTTOM BEARING PLATE AND BASE CYLINDER PLAN**

**BEARING DESIGN INFORMATION**

Design Information	Location	
	W. Abut.	E. Abut.
Vertical Design Load (Kips)	284	267
Pay Item Size (Kips)	300	300
Lateral Load (Kips)	57	53
Total Required Movement (in)	5	5
All Design Rotation (Radians) **	0.02	0.02

Vertical Design Load = Total Vertical Dead Load + Live Load (No Impact)

Lateral Design Load = Larger of factored ultimate strength design lateral load or 20% of the vertical service

\*\* Includes maximum factored ultimate strength design rotation plus allowances for fabrication tolerances (.005 radians) and installation uncertainties (.005 radians)

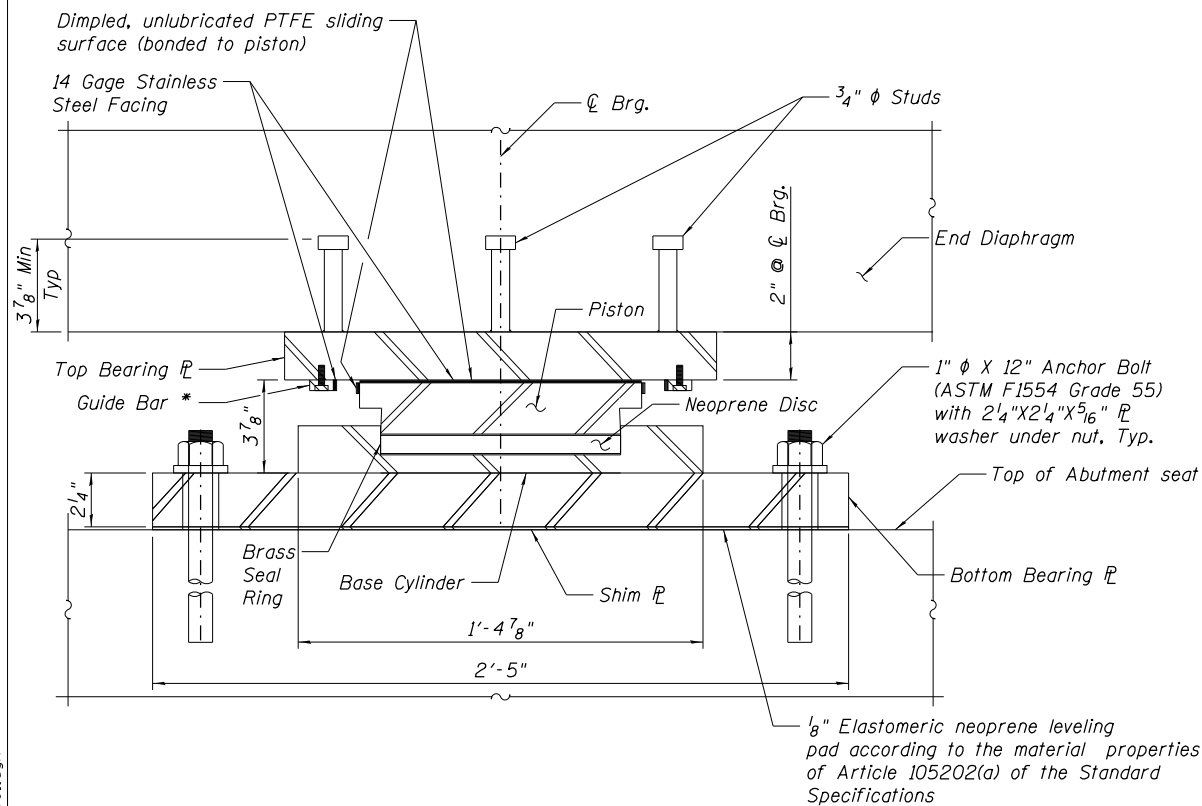

**SECTION A-A**

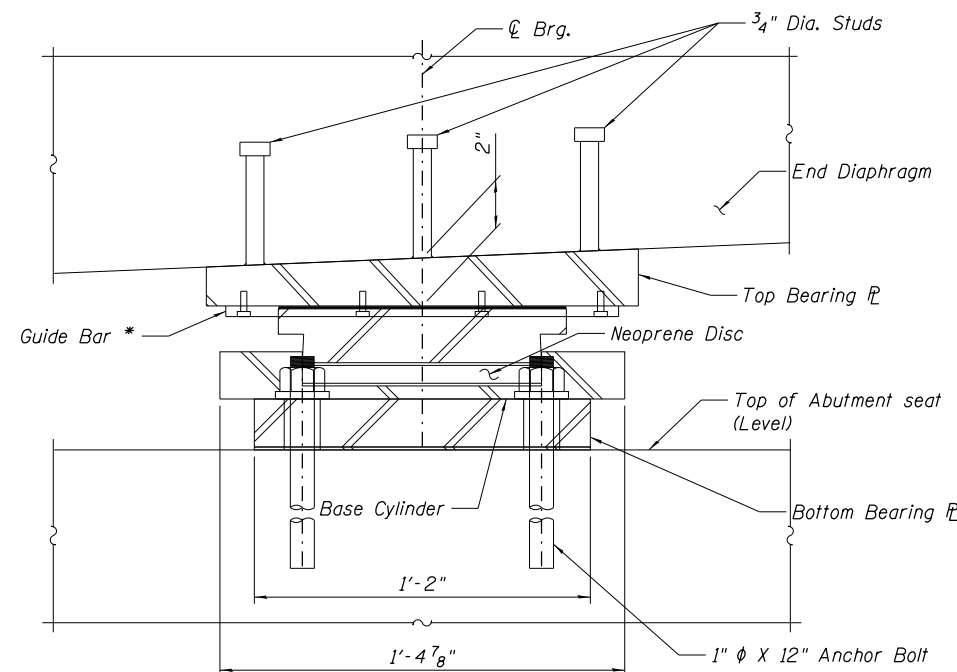

**SECTION B-B**

**Notes:**

- Anchor Bolts shall be ASTM F1554 all-thread (or an Engineer - approved alternate material) of the grade(s) and diameter(s) specified. The corresponding specified grade of AASHTO M314 anchor bolts may be used in lieu of ASTM F1554.
- Drilled and set anchor bolts shall be installed according to Article 521.06 of the Standard Specifications.
- The PTFE sheet shall be bonded directly to the piston with a two-component, medium viscosity epoxy resin, conforming to the requirements of the Federal Specification MMM-A-134, Type 1. The bond agent shall be applied on the full area of the contact surfaces.
- Bonding of PTFE sheet during vulcanizing process will be permitted provided the process and method of adjusting assembly height is approved by the Engineer.
- The structural steel plates of the Bearing Assembly shall conform to the requirements of AASHTO M 270 Grade 50W.
- Two 3/8 in. adjusting shims shall be provided for each bearing in addition to all other plates or shims and placed as shown on bearing details.
- Total bearing height is estimated based on manufacturer data. Actual bearing height may differ from contract plans. The Contractor shall be responsible for verifying bearing heights and adjusting seat elevations, if required, prior to placing abutment concrete. Total bearing height is taken at the center of bearing for beveled top plates.

**BILL OF MATERIAL**

Item	Unit	Total
High Load Multi-Rotational Bearing, Expansion - 300 Kips	Each	4
Anchor Bolts, 1"	Each	16

FILE NAME = 045P008-XXXX-028-BRGDET01.dgn

<b>TYLIN INTERNATIONAL</b>	USER NAME = RSTONE	DESIGNED - E. Modarres	REVISED - -
	PLOT SCALE = NO SCALE	CHECKED - P. Frey	REVISED - -
	PLOT DATE = 10/19/2017	DRAWN - O. Colcol	REVISED - -
		CHECKED - D. Fitzwilliam	REVISED - -

**STATE OF ILLINOIS  
DEPARTMENT OF TRANSPORTATION**

**BEARING DETAILS  
STRUCTURE NO. 045-P008**

SHEET NO. S-28 OF S-69 SHEETS

F.A.U. RTE.	SECTION	COUNTY	TOTAL SHEETS	SHEET NO.
2503	16-00313-00-MS	KANE	254	189
CONTRACT NO.			61E18	
ILLINOIS FED. AID PROJECT				

- NOTES:
1. For approach slab details, see "WEST BRIDGE APPROACH SLAB" sheet.
  2. For pile cap layout, see "WEST ABUTMENT DETAILS" sheet.
  3. Reinforcement spacing in the cap shall be adjusted to maintain 4" clear spacing to anchor bolts.
  4. For exp. joint details, see "EXPANSION JOINT DETAILS 1" sheet.
  5. For architectural monument details, see "ARCHITECTURAL DETAILS 3" sheet.

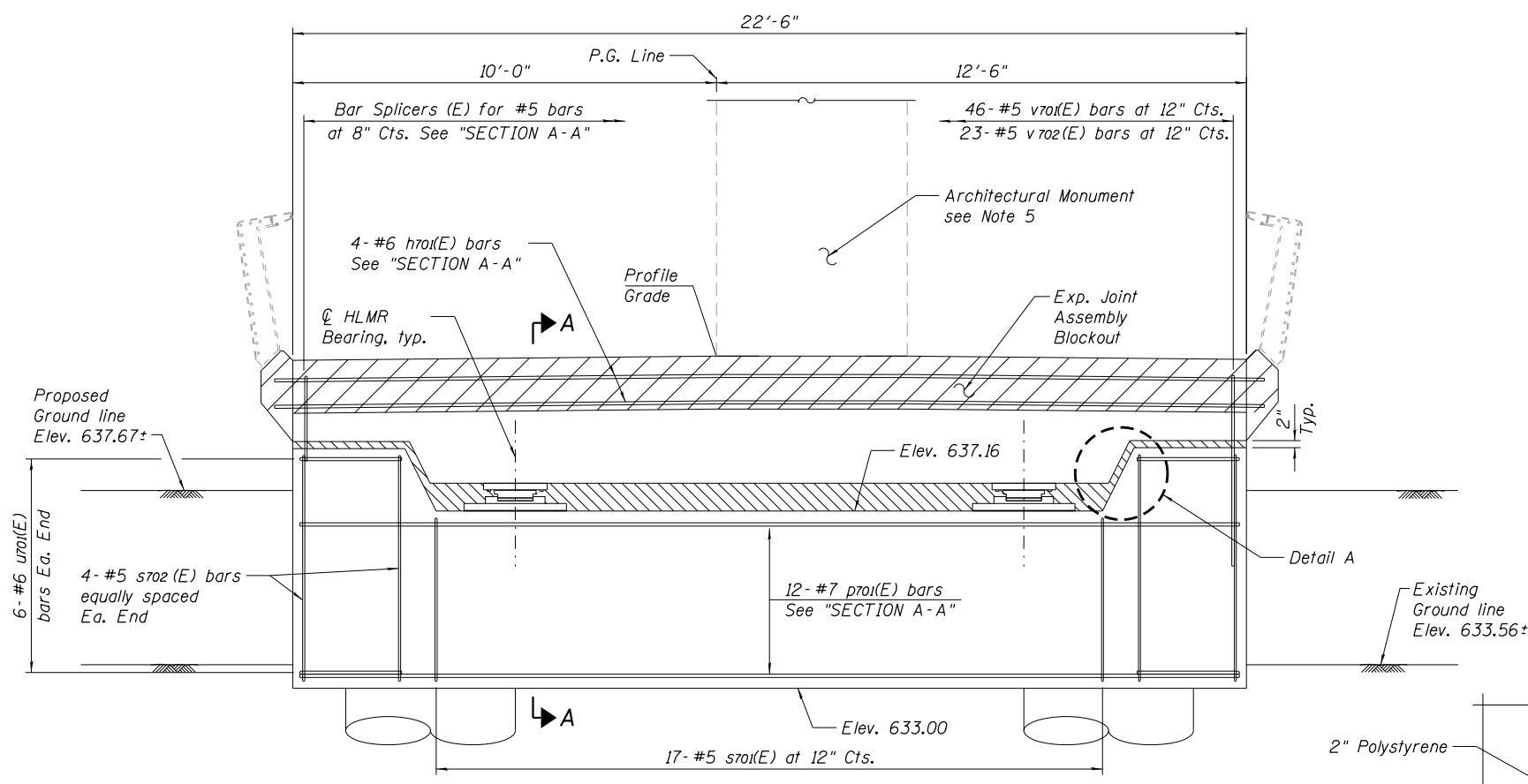

**ELEVATION**  
(Looking West)

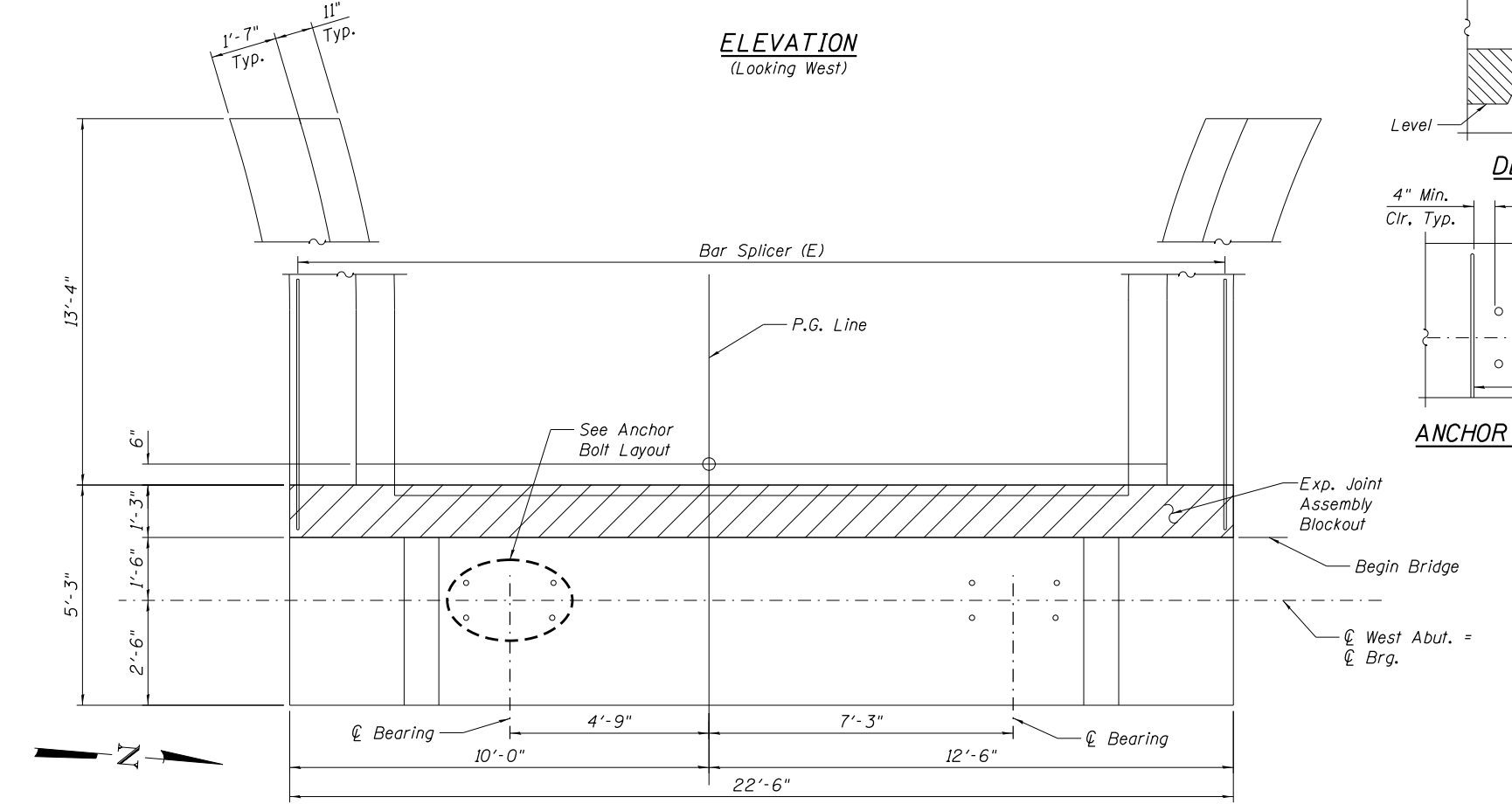

**TOP VIEW**

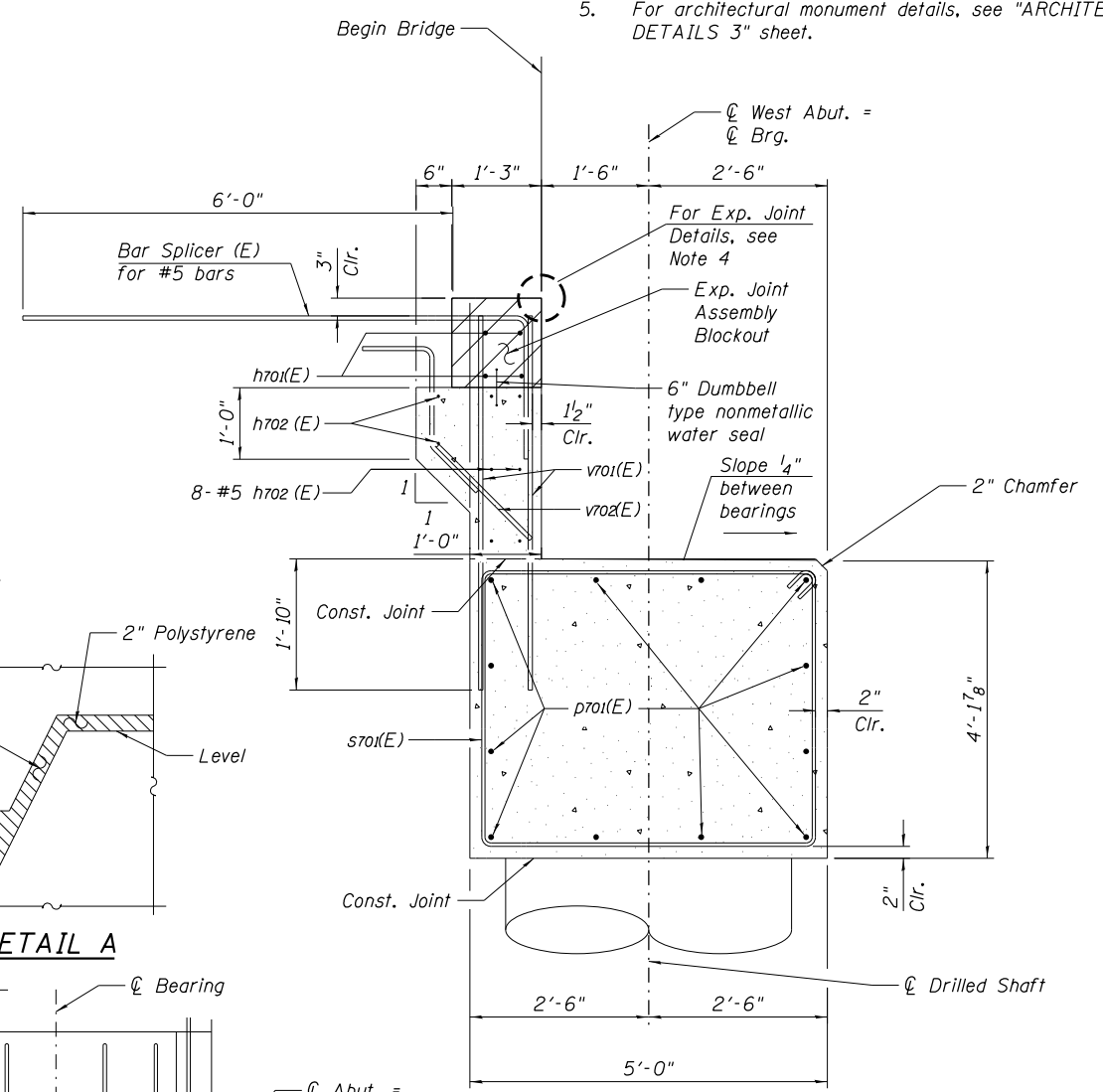

**SECTION A-A**

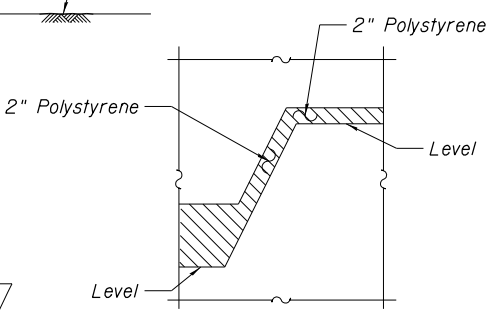

**DETAIL A**

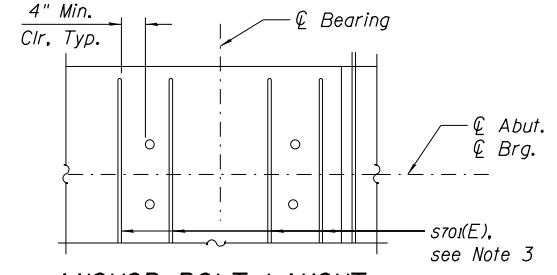

**ANCHOR BOLT LAYOUT**

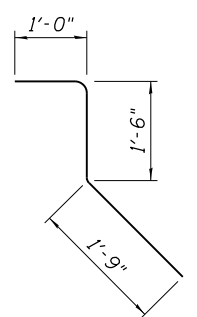

**BAR v702 (E)**

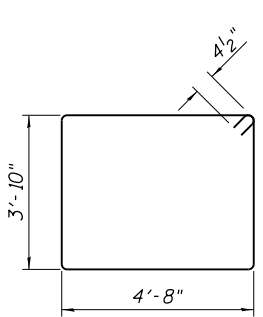

**BAR s701 (E)**

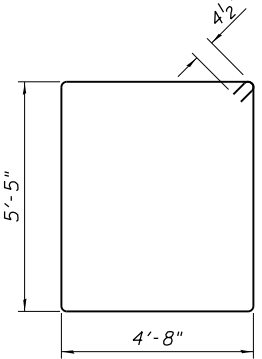

**BAR s702 (E)**

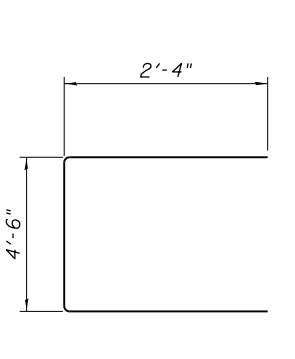

**BAR u701 (E)**

FILE NAME = 045P008-XXXX-029-WESTABUT01.dgn

**TYLIN INTERNATIONAL**

USER NAME = RSTONE	DESIGNED - E. Modarres	REVISED - -
CHECKED - P. Frey	REVISIONS - -	
PLOT SCALE = NO SCALE	DRAWN - I. Martin	REVISED - -
PLOT DATE = 10/19/2017	CHECKED - D. Fitzwilliam	REVISED - -

**STATE OF ILLINOIS  
DEPARTMENT OF TRANSPORTATION**

**WEST ABUTMENT LAYOUT  
STRUCTURE NO. 045-P008**

SHEET NO. S-29 OF S-69 SHEETS

F.A.U. RT.E.	SECTION	COUNTY	TOTAL SHEETS	SHEET NO.
2503	16-00313-00-MS	KANE	254	190
CONTRACT NO.			61E18	
ILLINOIS FED. AID PROJECT				

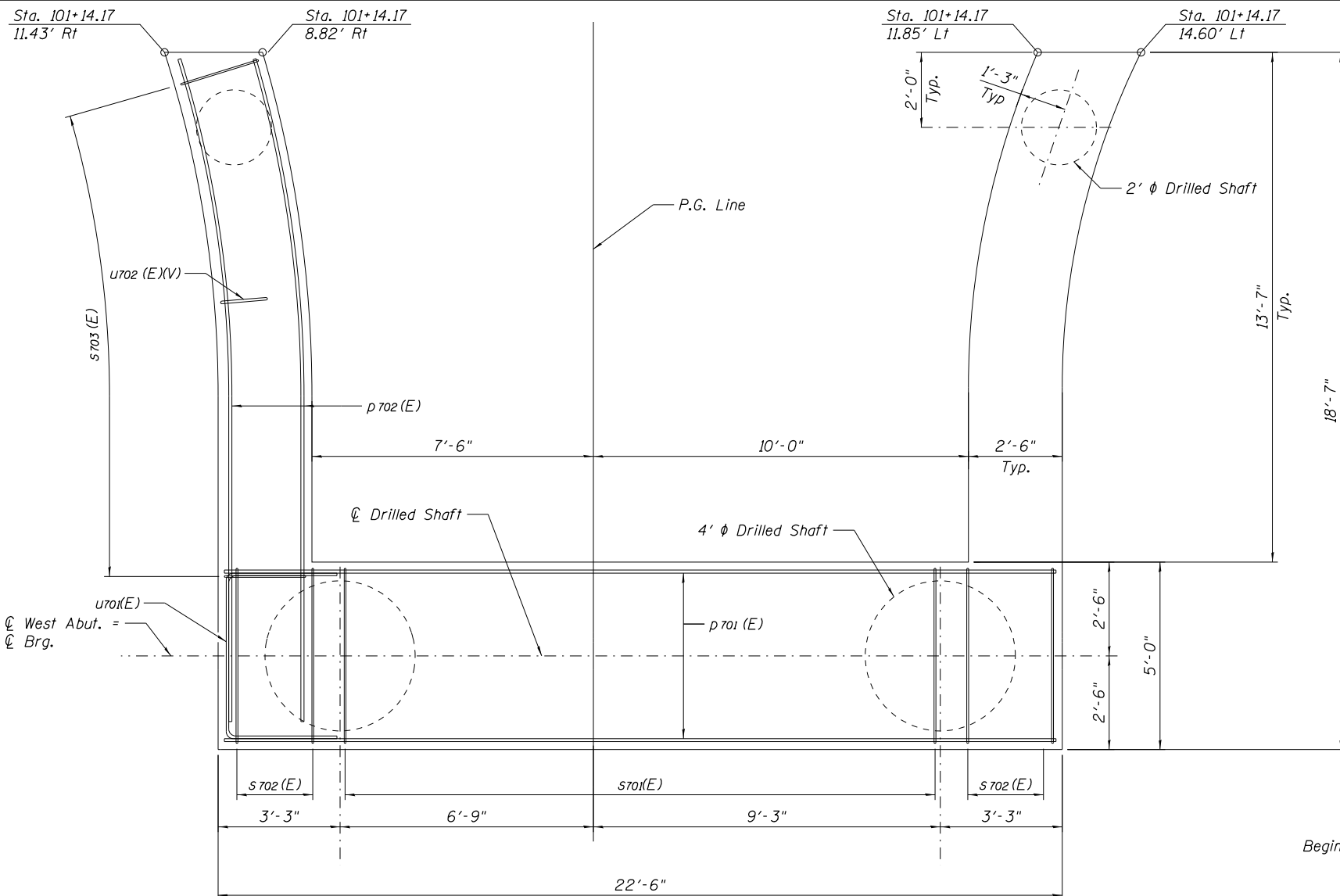

- NOTES:
1. For approach slab details, see "WEST BRIDGE APPROACH SLAB" sheet.
  2. For drilled shaft details, see "WEST ABUTMENT DETAILS 2" sheet.
  3. For details of Bar Splicers, see "BAR SPLICE ASSEMBLY & MECHANICAL SPLICER DETAILS" sheet.

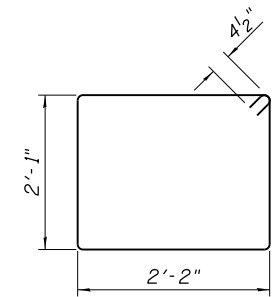

BAR s703 (E)

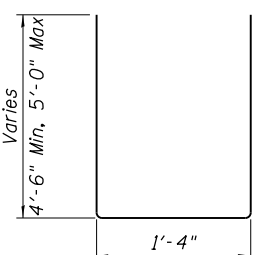

BAR u702 (E)(V)

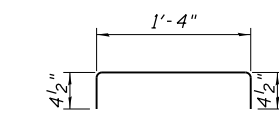

BAR u703 (E)

**WEST ABUTMENT  
BILL OF MATERIAL**

Bar	No.	Size	Length	Shape
h701 (E)	4	#6	23'-6"	—
h702 (E)	8	#5	22'-0"	—
h703 (E)	4	#5	17'-6"	—
h704 (E)	12	#5	17'-6"	—
p701 (E)	12	#7	22'-0"	—
p702 (E)	16	#7	17'-6"	—
s701 (E)	17	#5	17'-9"	□
s702 (E)	8	#5	20'-11"	□
s703 (E)	30	#5	9'-3"	□
sp701 (E)	2	#6	22'-0"*	—
sp702 (E)	2	#4	18'-0"*	—
u701 (E)	12	#6	9'-2"	—
u702 (E) Min	30	#6	10'-4"	—
u702 (E) Max	30	#6	11'-4"	—
u703 (E)	30	#4	2'-1"	—
v701 (E)	46	#5	5'-3"	—
v702 (E)	23	#5	4'-3"	—
v703 (E)	44	#8	24'-10"	—
v704 (E)	20	#8	20'-1"	—
Structure Excavation			Cu. Yd.	23
Concrete Structures			Cu. Yd.	34.6
Reinforcement Bars, Epoxy Coated			Pound	9102
Drilled Shaft in Soil			Cu. Yd.	16.3
Drilled Shaft in Rock			Cu. Yd.	6.2
Granular Backfill for Structures			Cu. Yd.	35
Crosshole Sonic Logging Access Duct			Foot	44
Pipe Underdrain for Structures 4"			Foot	58
Geocomposite Wall Drain			Sq. Yd.	17

\* Length is height of spiral

**PLAN - PILE CAP**

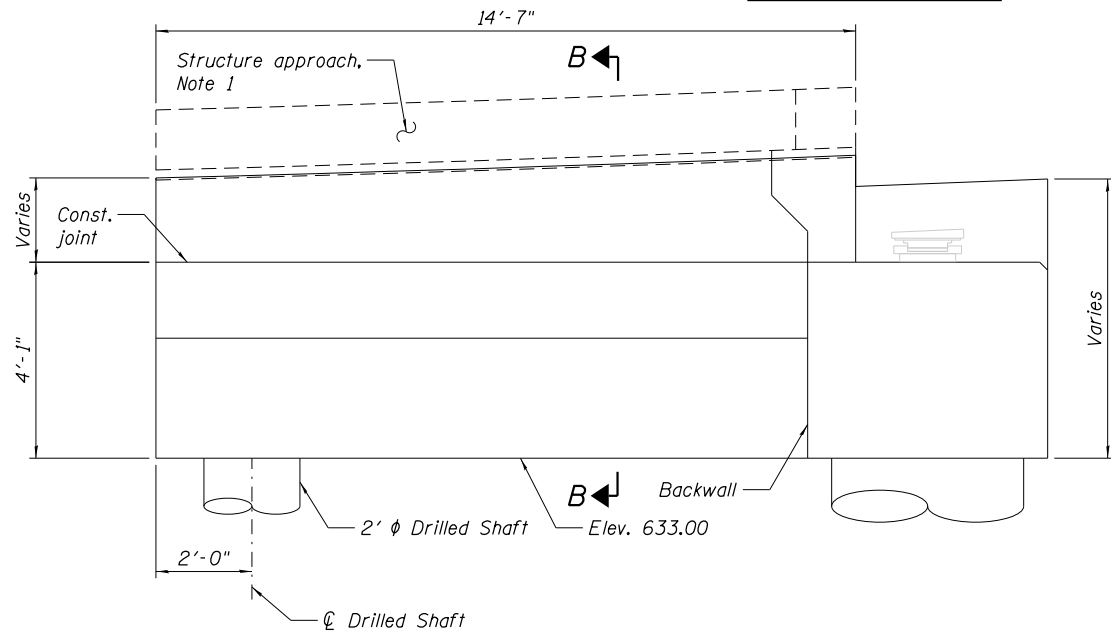

WINGWALL ELEVATION  
(Showing dimensions)

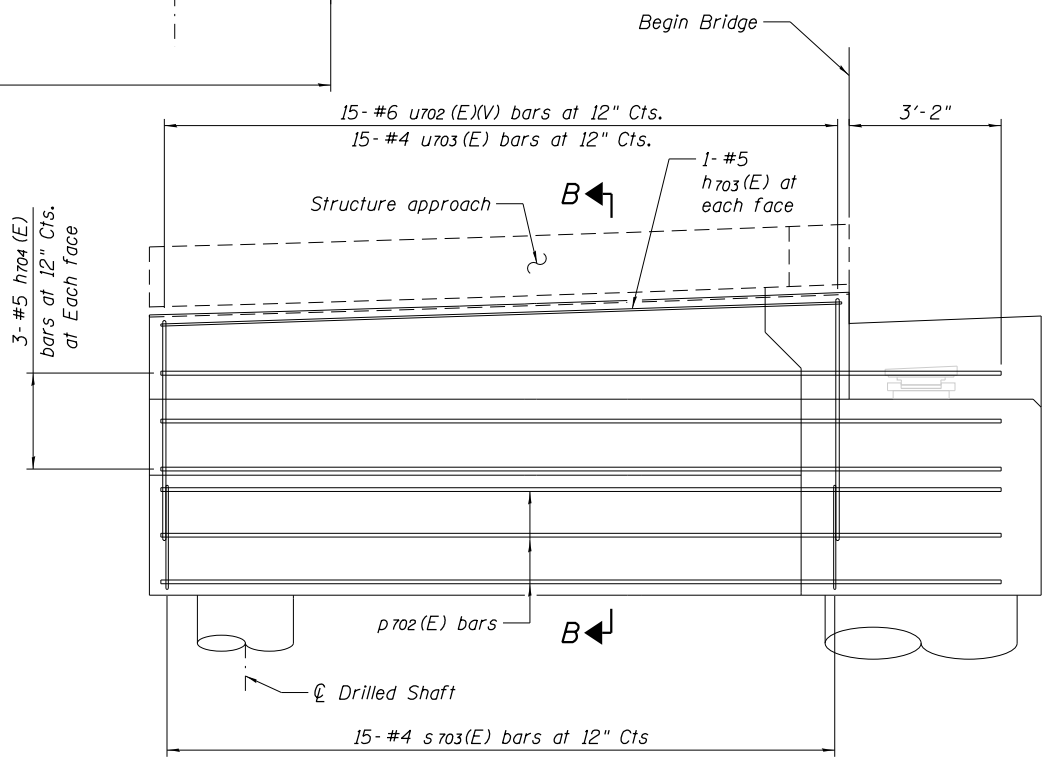

WINGWALL ELEVATION  
(Showing Reinforcement)

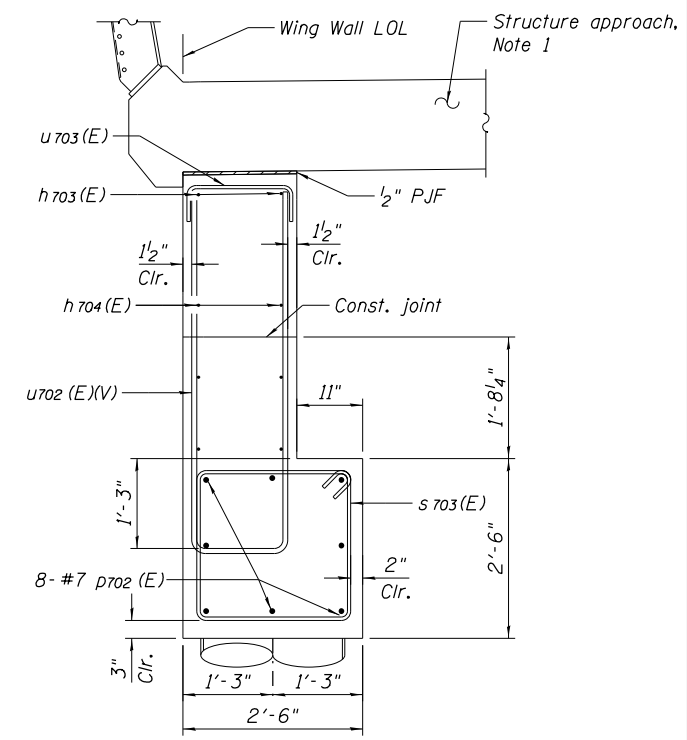

SECTION B-B

FILE NAME = 045P008-XXXX-030-WESTABUT02.dgn

<b>TYLIN INTERNATIONAL</b>	USER NAME = RSTONE	DESIGNED - E. Modarres	REVISED - -
	PLOT SCALE = NO SCALE	CHECKED - P. Frey	REVISED - -
	PLOT DATE = 10/19/2017	DRAWN - I. Martin	REVISED - -
		CHECKED - D. Fitzwilliam	REVISED - -

STATE OF ILLINOIS  
DEPARTMENT OF TRANSPORTATION

WEST ABUTMENT DETAILS 1  
STRUCTURE NO. 045-P008

SHEET NO. S-30 OF S-69 SHEETS

F.A.U. RTE.	SECTION	COUNTY	TOTAL SHEETS	SHEET NO.
2503	16-00313-00-MS	KANE	254	191
CONTRACT NO.			61E18	

ILLINOIS FED. AID PROJECT

FILE NAME = 045P008-XXXX-031-WESTABUT03.dgn

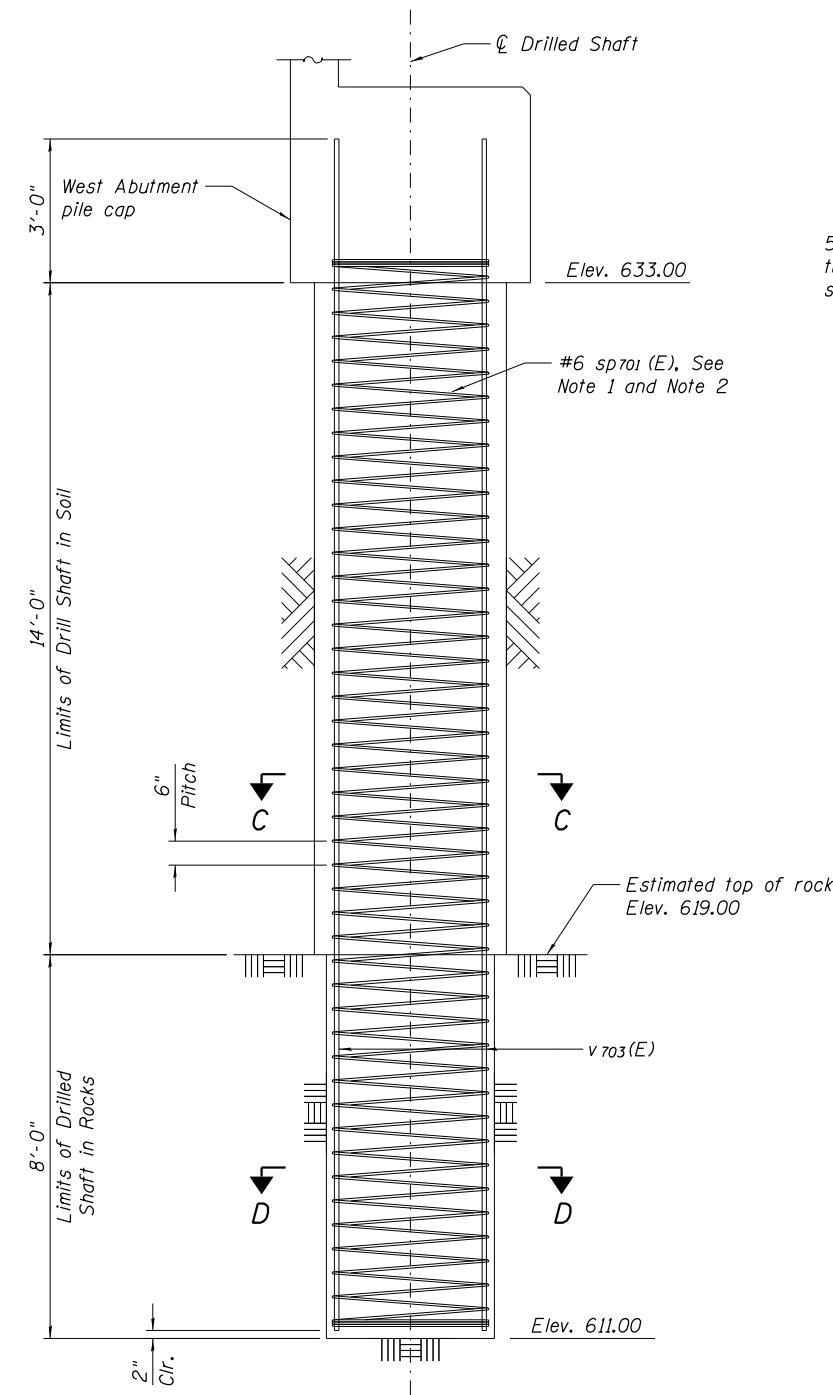

**DRILLED SHAFT DETAIL**

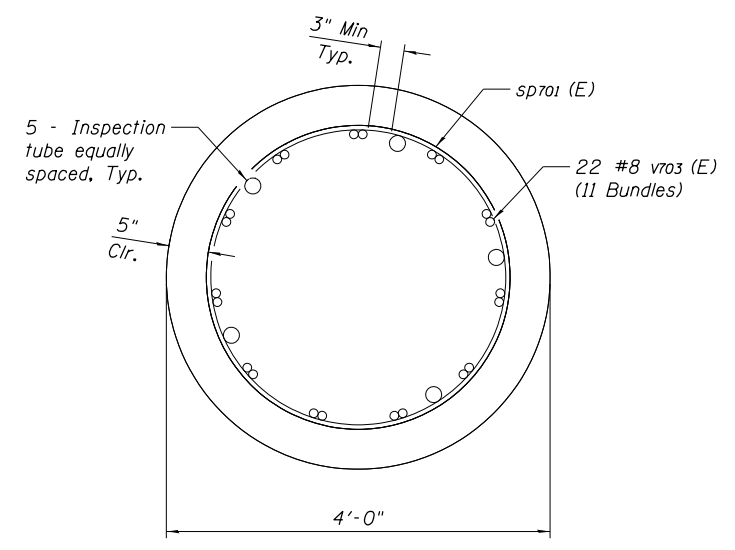

**C-C PILE SECTION**

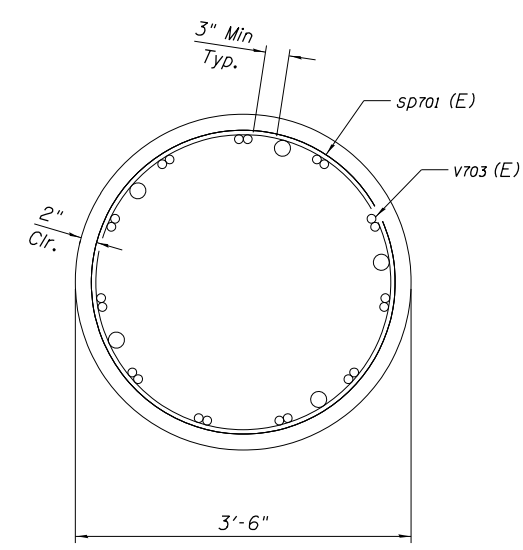

**D-D ROCK SOCKET**

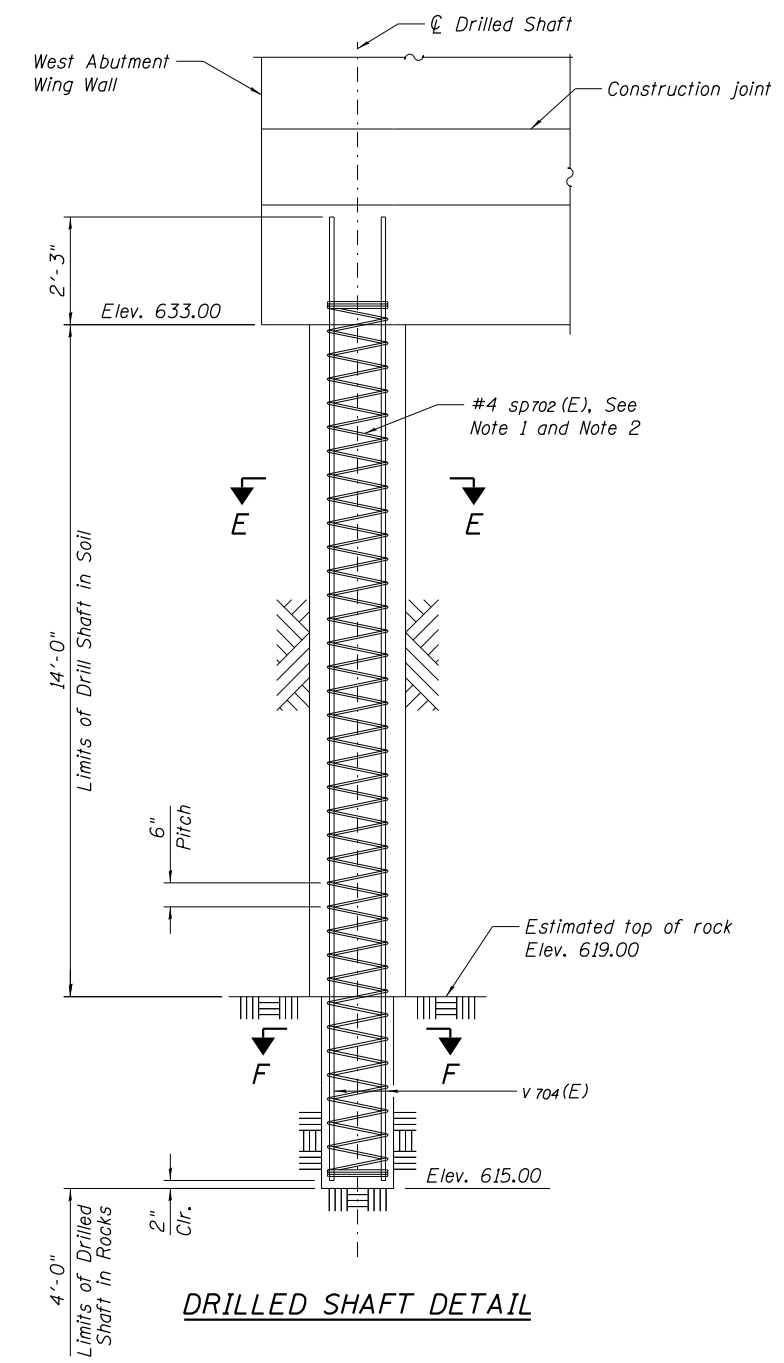

**DRILLED SHAFT DETAIL**

- NOTES:**
1. Provide 1/2 extra turns, shop welded together per AWS D1.4 top and bottom. Extend spiral 2" into abutment cap. Provide 4- #4 spacers or equivalent.
  2. When splicing spiral reinforcement is necessary, the spiral shall be provided with 1/2 extra turns at the ends to be spliced. these additional turns shall be welded together according to AWS D1.4.

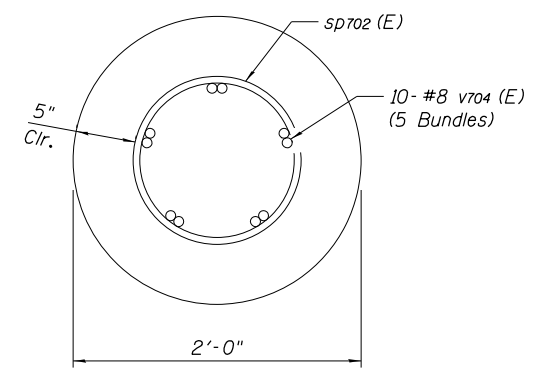

**E-E PILE SECTION**

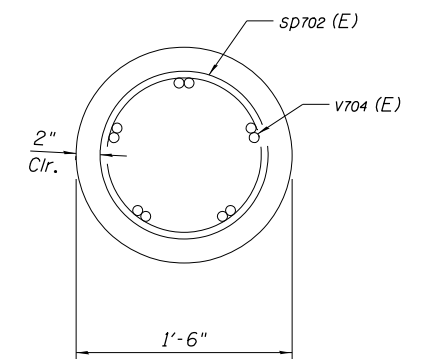

**F-F ROCK SOCKET**



USER NAME = RSTONE	DESIGNED - E. Modarres	REVISED - -
	CHECKED - P. Frey	REVISED - -
PLOT SCALE = NO SCALE	DRAWN - I. Martin	REVISED - -
PLOT DATE = 10/19/2017	CHECKED - D. Fitzwilliam	REVISED - -

**STATE OF ILLINOIS  
DEPARTMENT OF TRANSPORTATION**

**WEST ABUTMENT DETAILS 2  
STRUCTURE NO. 045-P008**

SHEET NO. S-31 OF S-69 SHEETS

F.A.U. RE.	SECTION	COUNTY	TOTAL SHEETS	SHEET NO.
2503	16-00313-00-MS	KANE	254	192
CONTRACT NO.			61E18	

ILLINOIS FED. AID PROJECT

FILE NAME = 045P008-XXXX-032-EASTABUT01.dgn

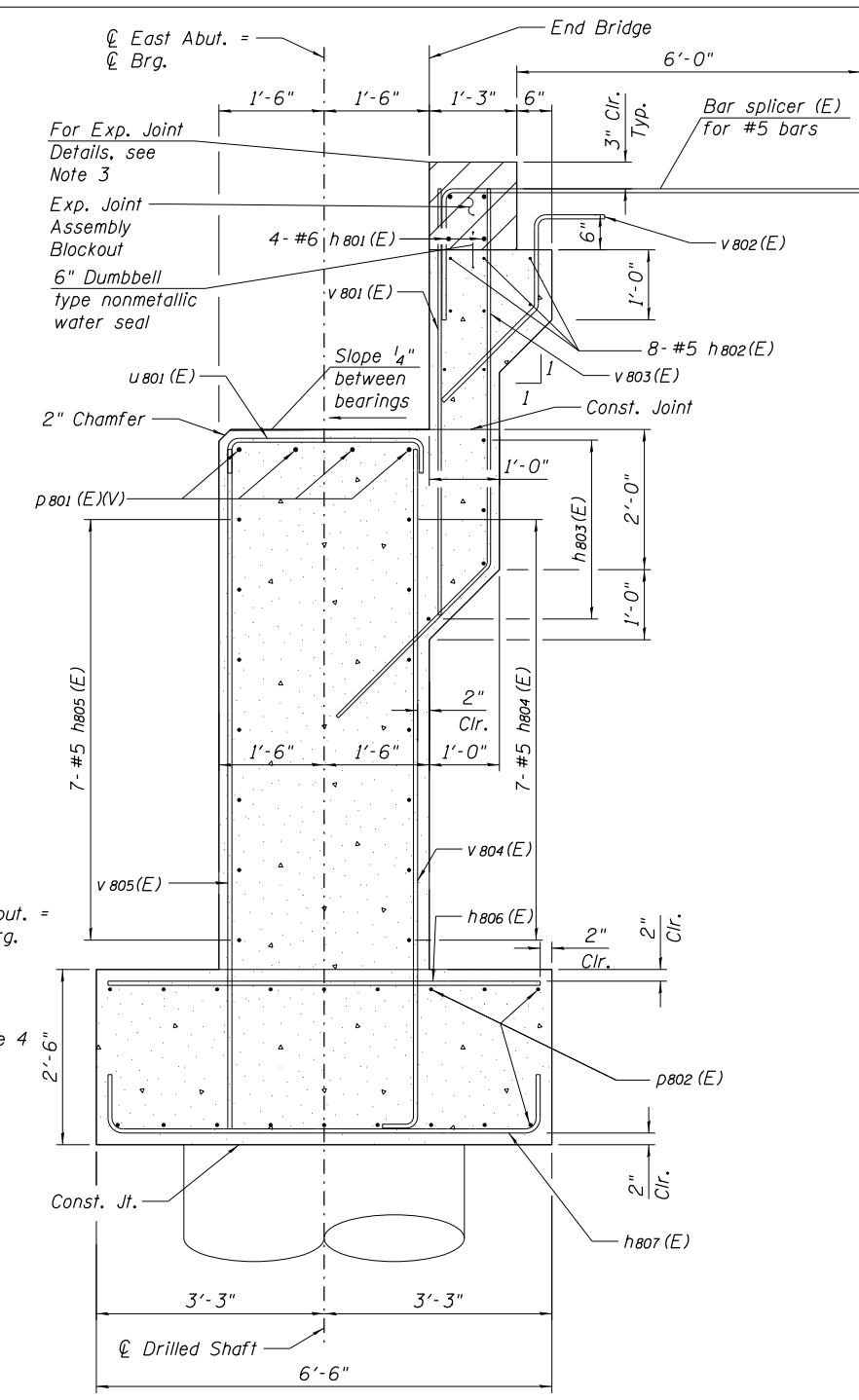
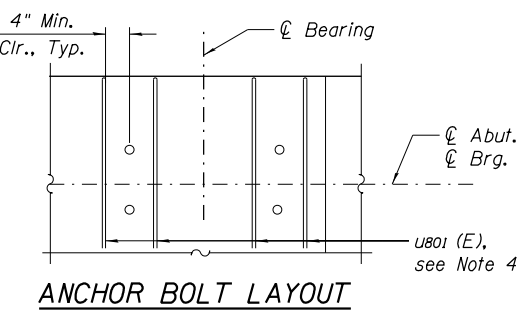
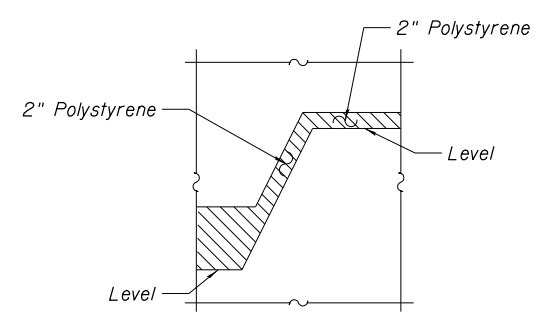
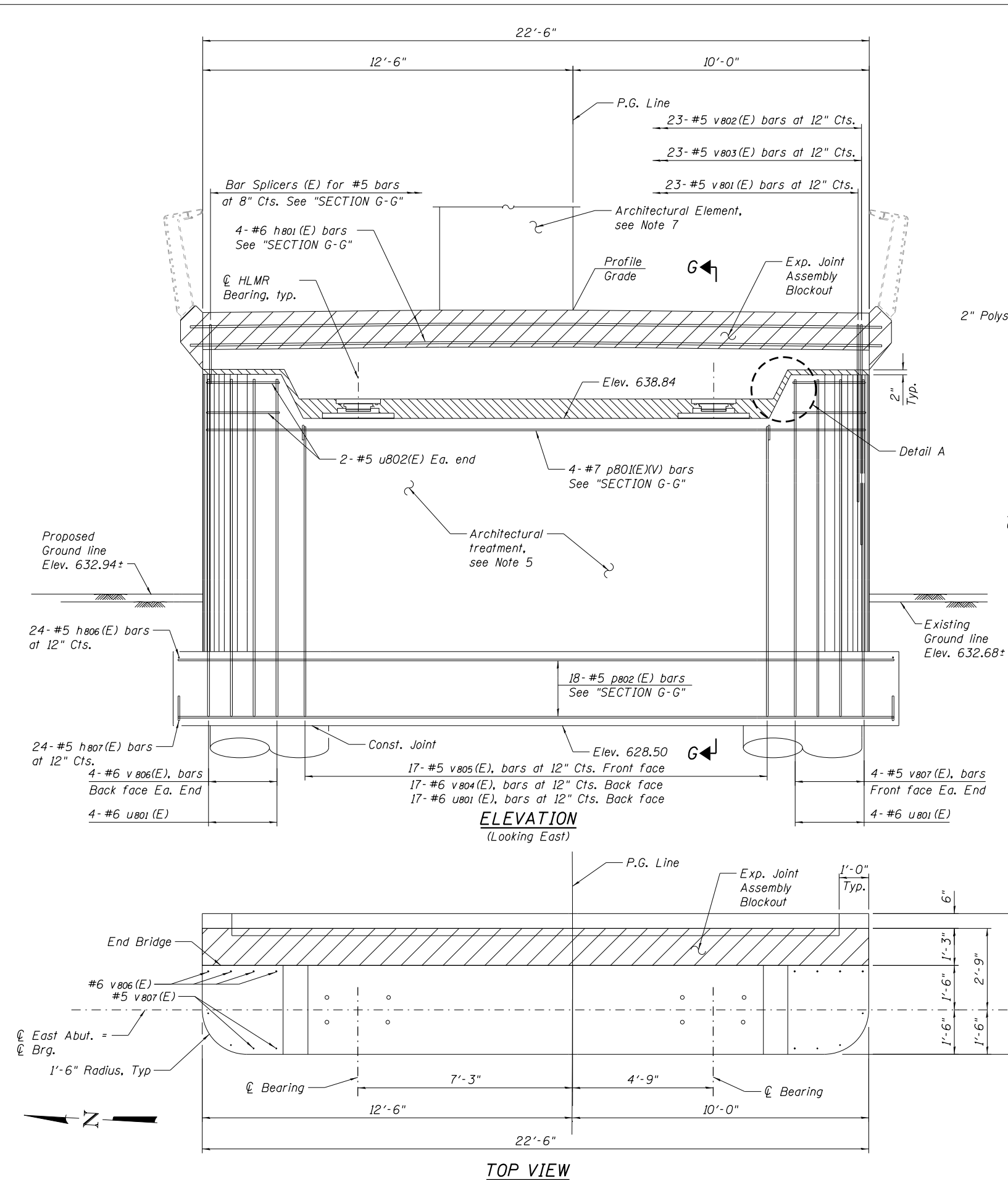

- NOTES:**
1. For approach slab details, see "EAST BRIDGE APPROACH SLABS" sheet.
  2. For pile cap layout, see "EAST ABUTMENT DETAILS 1" sheet.
  3. For exp. jt. details, see "EXPANSION JOINT DETAILS 1" sheet.
  4. Reinforcement spacing in the cap should be adjusted to maintain 4" clear spacing to anchor bolts.
  5. For architectural treatment of abutment and stubwall, see "ARCHITECTURAL DETAILS 4" sheet.
  6. For bar shapes, see "EAST ABUTMENT DETAILS 2" sheet.
  7. For architectural monument details, see "ARCHITECTURAL DETAILS 3" sheet.

	USER NAME = RSTONE	DESIGNED - E. Modarres	REVISED - -	<b>STATE OF ILLINOIS</b> <b>DEPARTMENT OF TRANSPORTATION</b>	<b>EAST ABUTMENT LAYOUT</b> <b>STRUCTURE NO. 045-P008</b>	F.A.U. RTE.	SECTION	COUNTY	TOTAL SHEETS	SHEET NO.
	PLOT SCALE = NO SCALE	CHECKED - P. Frey	REVISED - -			2503	16-00313-00-MS	KANE	254	193
	PLOT DATE = 10/19/2017	DRAWN - I. Martin	REVISED - -			CONTRACT NO.		61E18		

ILLINOIS FED. AID PROJECT

**EAST ABUTMENT  
BILL OF MATERIAL**

Bar	No.	Size	Length	Shape
h801(E)	4	#6	23'-6"	—
h802(E)	8	#5	22'-0"	—
h803(E)	4	#5	22'-0"	—
h804(E)	7	#5	22'-0"	—
h805(E)	7	#5	26'-4"	—
h806(E)	24	#5	6'-2"	—
h807(E)	24	#5	8'-2"	—
h808(E)	36	#4	3'-1"	—
h809(E)	4	#4	1'-5"	—
D801(E) Max	2	#7	22'-0"	—
D801(E) Min	2	#7	19'-0"	—
D802(E)	18	#5	23'-6"	—
U801(E)	25	#6	4'-8"	—
U802(E)	4	#5	7'-1"	—
V801(E)	23	#5	6'-2"	—
V802(E)	23	#5	4'-3"	—
V803(E)	23	#5	8'-5"	—
V804(E)	17	#6	10'-11"	—
V805(E)	17	#5	9'-11"	—
V806(E)	8	#6	12'-6"	—
V807(E)	8	#5	11'-6"	—
V808(E)	8	#5	11'-11"	—
V809(E)	44	#8	33'-0"	—
SP801(E)	2	#4	30'-6"	—
Structure Excavation			Cu. Yd.	45
Concrete Structures			Cu. Yd.	41
Reinforcement Bars, Epoxy Coated			Pound	8168
Drilled Shaft in Soil			Cu. Yd.	20.5
Drilled Shaft in Rock			Cu. Yd.	5.7
Granular Backfill for Structures			Cu. Yd.	18
Crosshole Sonic Logging Access Duct			Foot	60
Pipe Underdrain for Structures 4"			Foot	80
Geocomposite Wall Drain			Sq. Yd.	27

\* Length is height of spiral

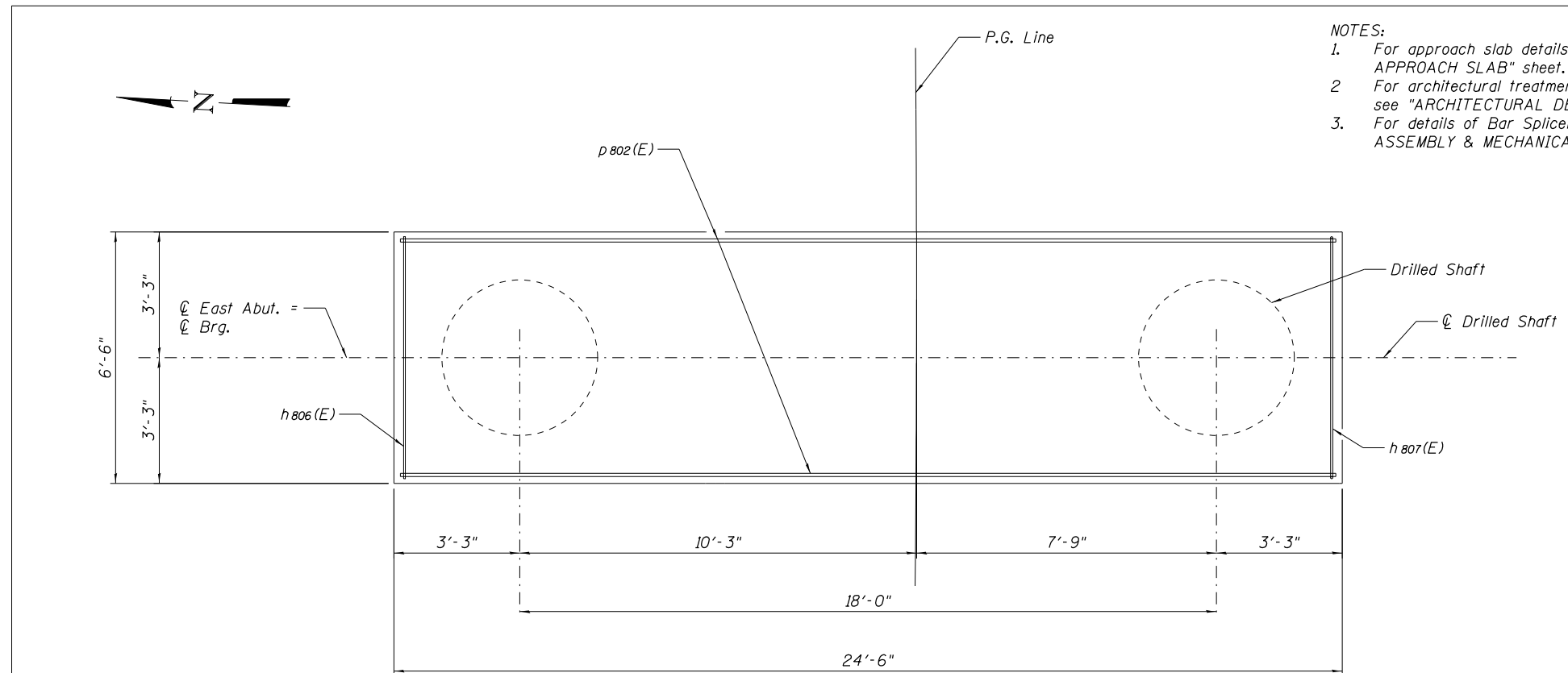

**PLAN - PILE CAP**

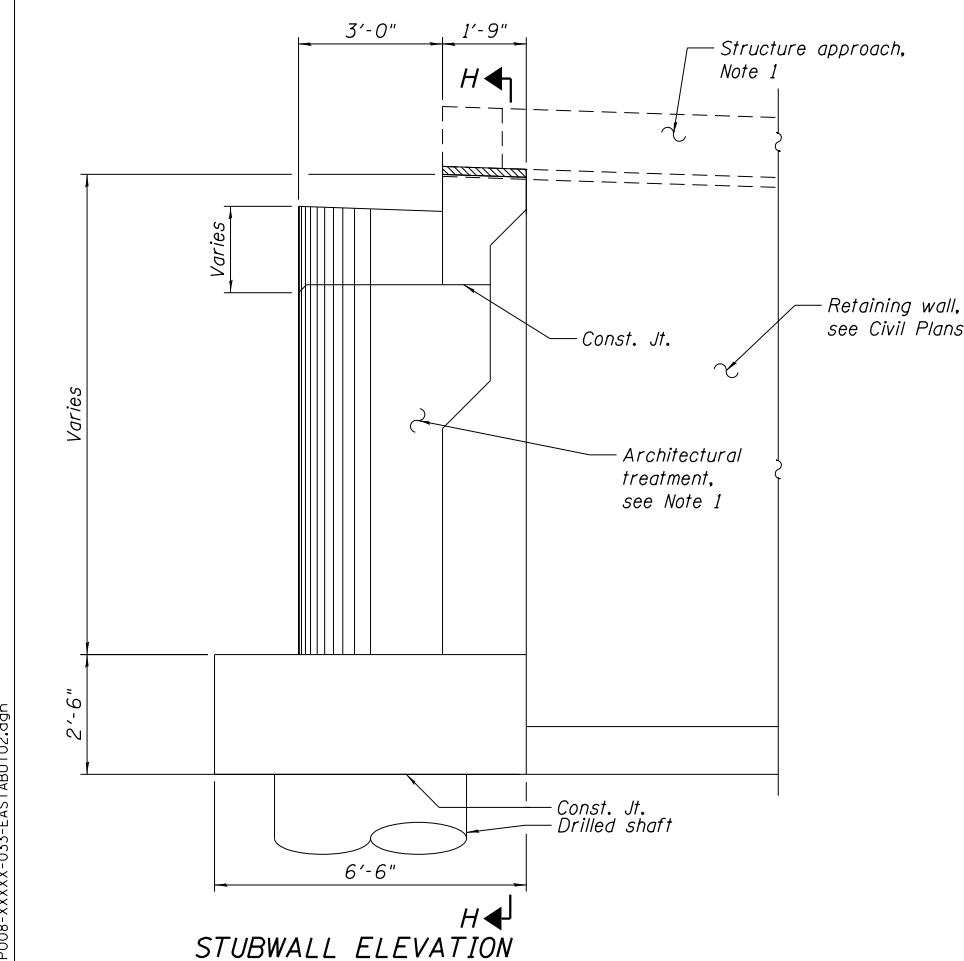

**STUBWALL ELEVATION**

(Showing dimensions)

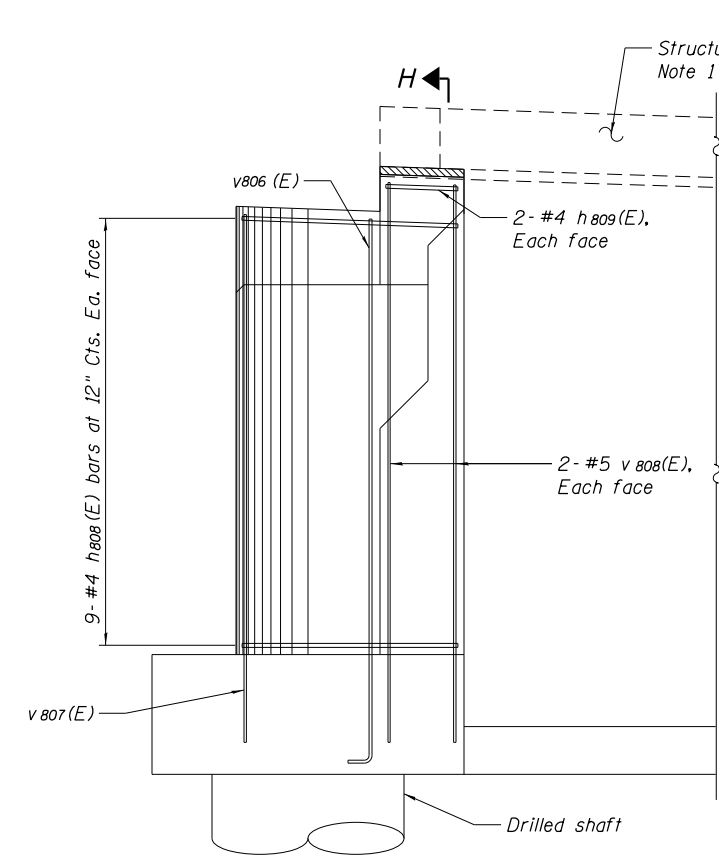

**STUBWALL ELEVATION - REINFORCEMENT**

(Showing Reinforcement)

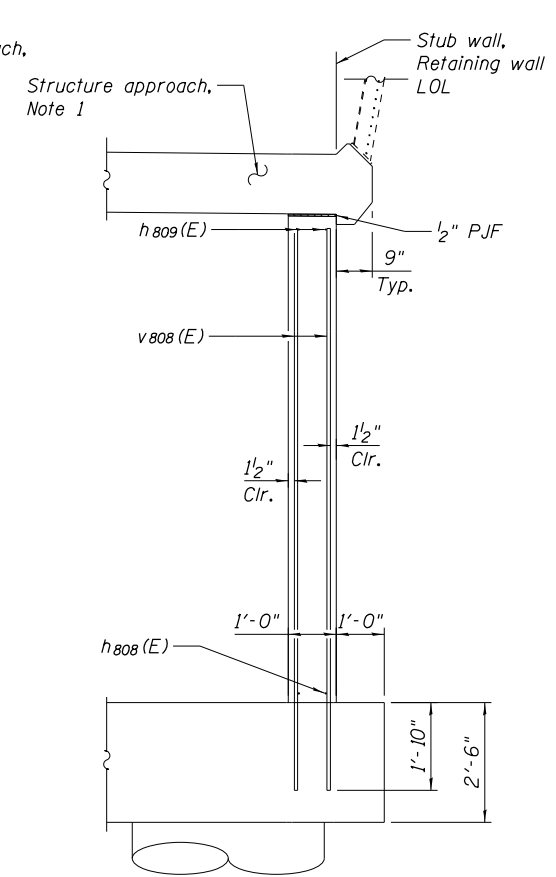

**H-H STUBWALL SECTION**

FILE NAME = 045P008-XXXX-033-EASTABUT02.dgn

**TYLIN INTERNATIONAL**

USER NAME = RSTONE	DESIGNED - E. Modarres	REVISED - -
PLOT SCALE = NO SCALE	CHECKED - P. Frey	REVISED - -
PLOT DATE = 10/19/2017	DRAWN - I. Martin	REVISED - -
	CHECKED - D. Fitzwilliam	REVISED - -

**STATE OF ILLINOIS  
DEPARTMENT OF TRANSPORTATION**

**EAST ABUTMENT DETAILS 1  
STRUCTURE NO. 045-P008**

SHEET NO. S-33 OF S-69 SHEETS

F.A.U. RTE.	SECTION	COUNTY	TOTAL SHEETS	SHEET NO.
2503	16-00313-00-MS	KANE	254	194
CONTRACT NO.			61E18	

ILLINOIS FED. AID PROJECT

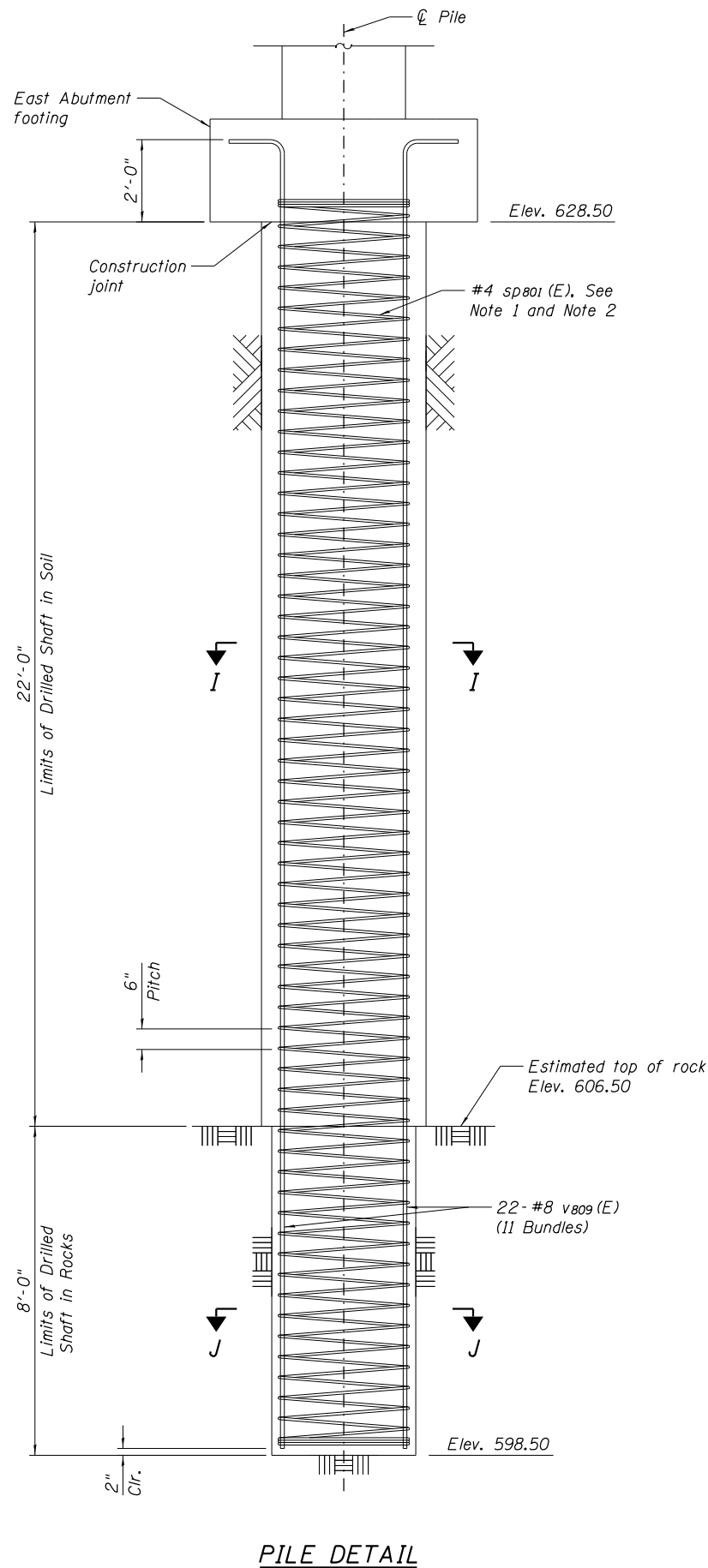

**PILE DETAIL**

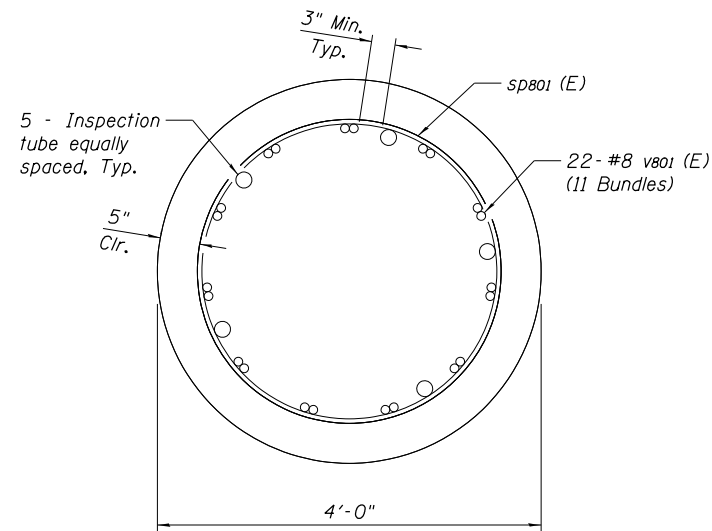

**I-I PILE SECTION**

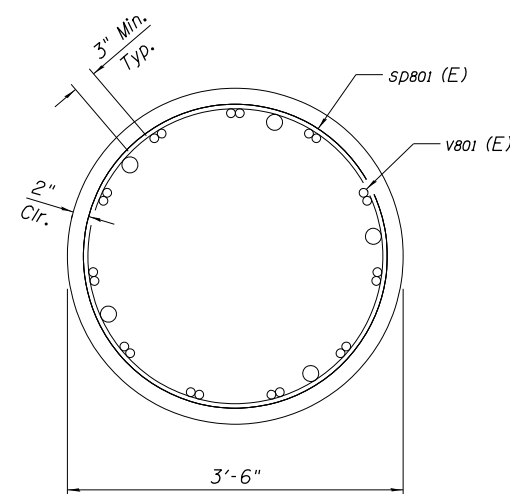

**J-J ROCK SOCKET**

- NOTES:**
1. Provide 1/2 extra turns, shop welded together per AWS D1.4 top and bottom. Extend spiral 2" into abutment cap. Provide 4- #4 spacers or equivalent.
  2. When splicing spiral reinforcement is necessary, the spiral shall be provided with 1/2 extra turns at the ends to be spliced. these additional turns shall be welded together according to AWS D1.4.

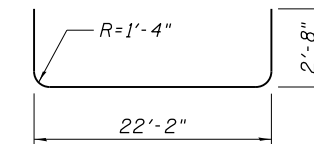

**BAR h805 (E)**

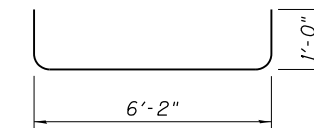

**BAR h807 (E)**

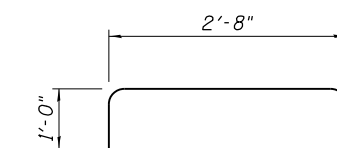

**BAR u801 (E)**

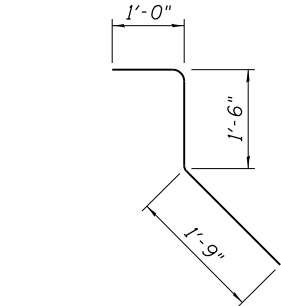

**BAR v802 (E)**

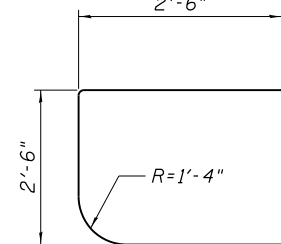

**BAR u802 (E)**

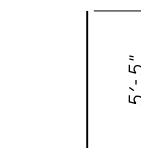

**BAR v803 (E)**

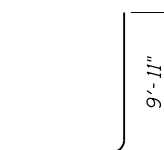

**BAR v804 (E)**



**BAR v806 (E)**

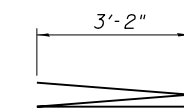

**BAR sp801 (E)**

FILE NAME = 045P008-XXXX-034-EASTABUT03.dgn

**TY-LIN INTERNATIONAL**

USER NAME = RSTONE	DESIGNED - E. Modarres	REVISED - -
PLOT SCALE = NO SCALE	CHECKED - P. Frey	REVISED - -
PLOT DATE = 10/19/2017	DRAWN - I. Martin	REVISED - -
	CHECKED - D. Fitzwilliam	REVISED - -

**STATE OF ILLINOIS  
DEPARTMENT OF TRANSPORTATION**

**EAST ABUTMENT DETAILS 2  
STRUCTURE NO. 045-P008**

SHEET NO. S-34 OF S-69 SHEETS

F.A.U. R.T.E.	SECTION	COUNTY	TOTAL SHEETS	SHEET NO.
2503	16-00313-00-MS	KANE	254	195
CONTRACT NO.			61E18	

ILLINOIS FED. AID PROJECT

FILE NAME = 045P008-XXXX-035-PIEROIDET.dgn

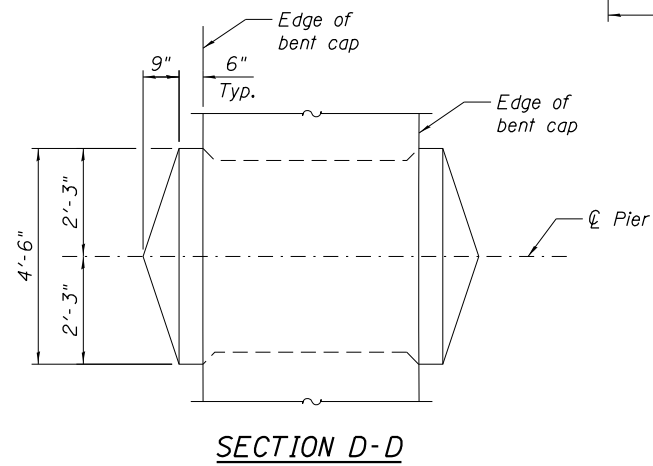
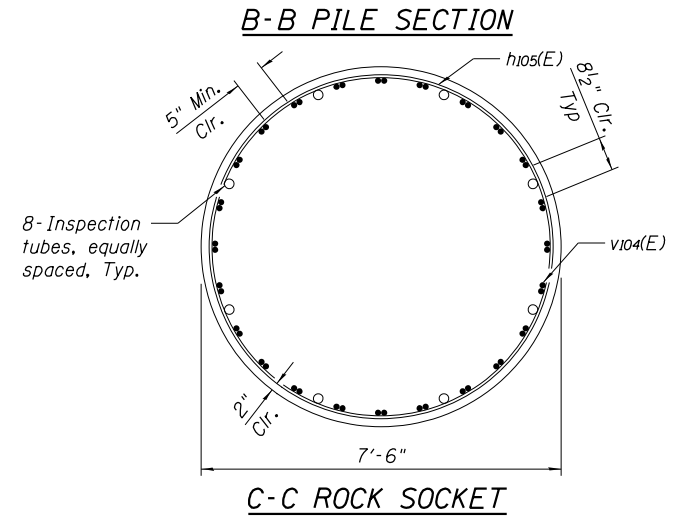
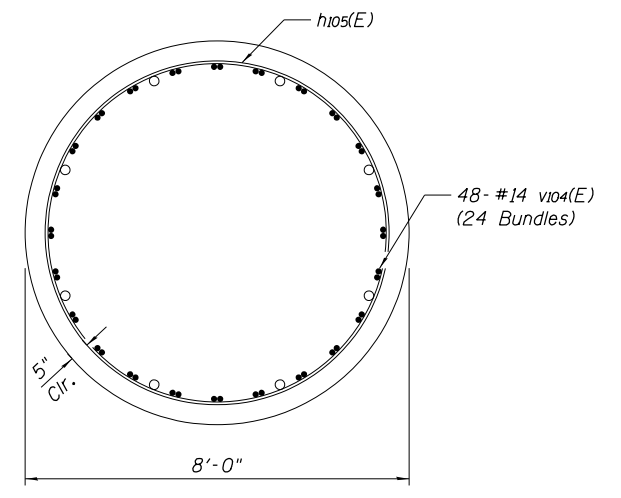
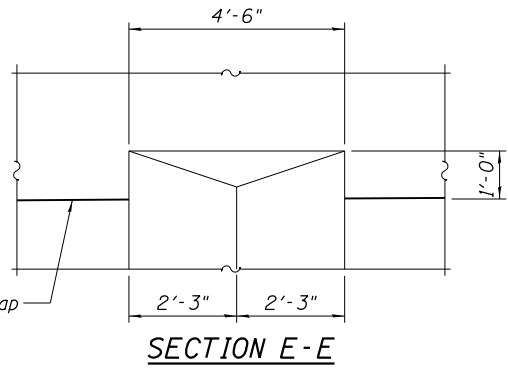
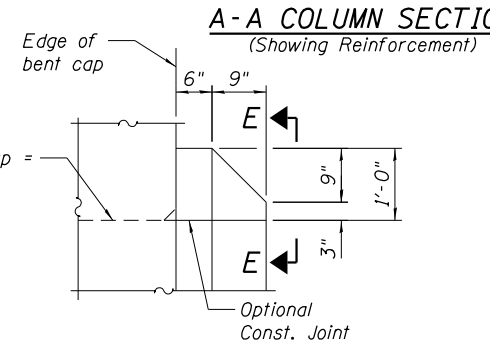
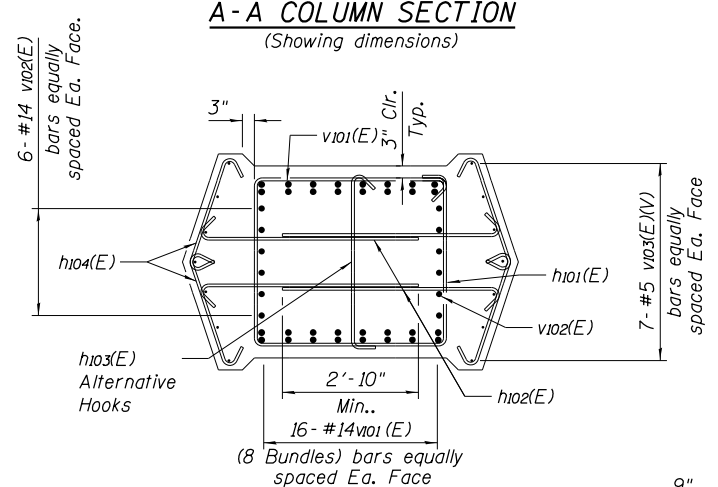
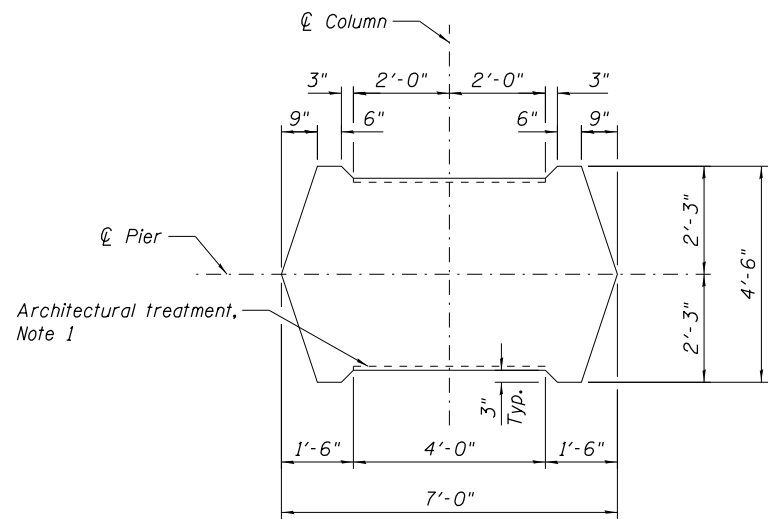
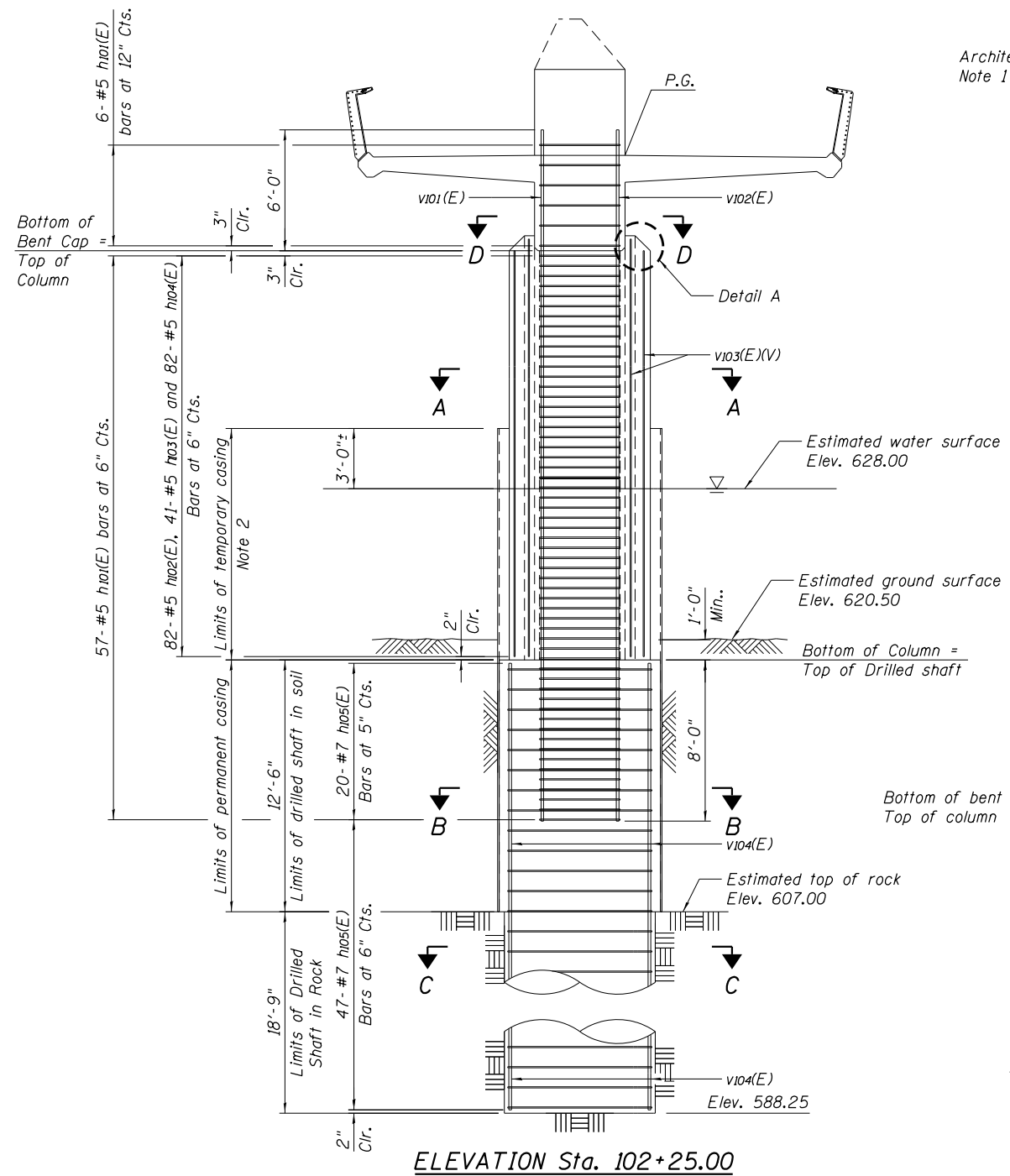

- NOTES:
- For Architectural treatment details and limits, see "ARCHITECTURAL DETAILS 4" sheet.
  - Temporary casing shall be removed after column concrete is set.
  - For bar shapes, see "PIER 2 DETAILS" sheet.

**PIER 1 BILL OF MATERIAL**

Bar	No.	Size	Length	Shape
h101(E)	63	#5	15'-9"	□
h102(E)	82	#5	9'-7"	┌┐
h103(E)	41	#5	4'-3"	┌┐
h104(E)	82	#5	6'-0"	┌┐
h105(E)	67	#7	22'-4"	○
v101(E)	32	#14	34'-4"	—
v102(E)	12	#14	34'-4"	—
v103(E) Min.	14	#5	20'-4"	—
v103(E) Max.	14	#5	20'-11"	—
v104(E)	48	#14	30'-11"	—
Concrete Structures			Cu. Yd.	19.8
Reinforcement Bars, Epoxy Coated			Pound	28,814
Drilled Shaft in Soil			Cu. Yd.	23.3
Drilled Shaft in Rock			Cu. Yd.	30.7
Permanent Casing			Foot	12.5
Crosshole Sonic Logging Testing			Each	1
Crosshole Sonic Logging Access Duct			Foot	31

USER NAME = RSTONE	DESIGNED - E. Modarres	REVISED - -
PLOT SCALE = NO SCALE	CHECKED - P. Frey	REVISED - -
PLOT DATE = 10/19/2017	DRAWN - I. Martin	REVISED - -
	CHECKED - D. Fitzwilliam	REVISED - -

STATE OF ILLINOIS  
DEPARTMENT OF TRANSPORTATION

PIER 1 DETAILS  
STRUCTURE NO. 045-P008

SHEET NO. S-35 OF S-69 SHEETS

F.A.U. R.T.E.	SECTION	COUNTY	TOTAL SHEETS	SHEET NO.
2503	16-00313-00-MS	KANE	254	196
CONTRACT NO.			61E18	
ILLINOIS FED. AID PROJECT				



FILE NAME = 045P008-XXXX-036-PIER2DET.dgn

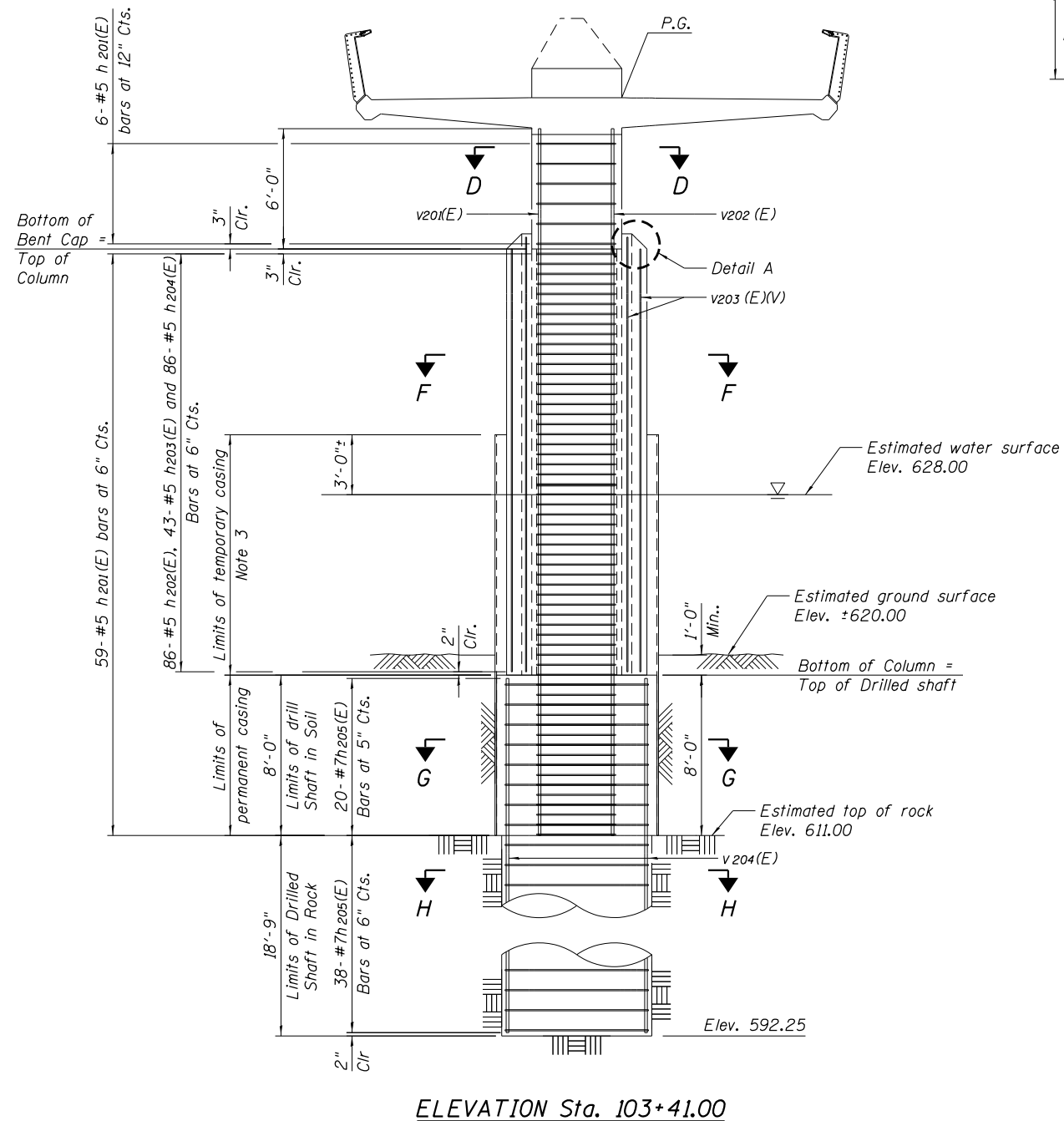

**ELEVATION Sta. 103+41.00**

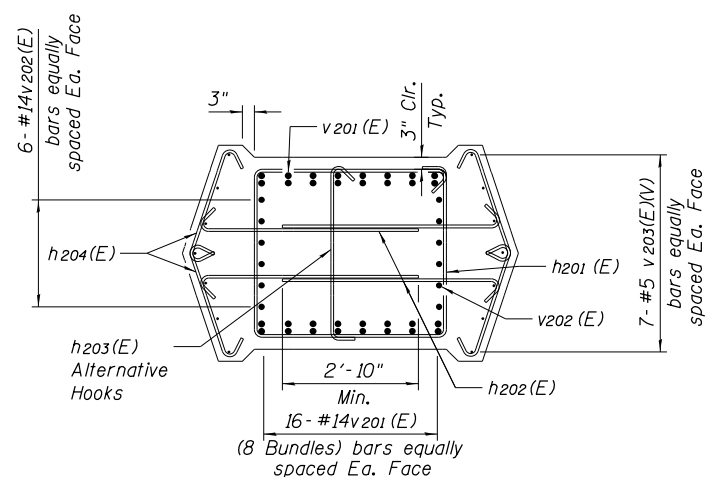

**F-F COLUMN SECTION**

Note 1

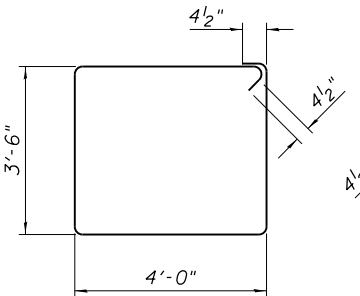

**BAR h101(E), h201(E),  
h301(E), h401(E),  
h501(E) and h601(E)**

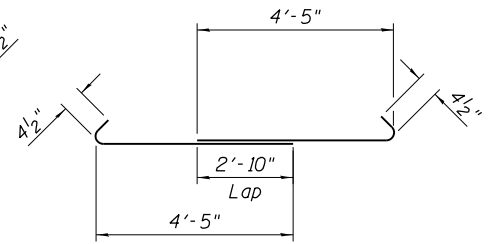

**BAR h102(E), h202(E),  
h302(E), h402(E),  
h502(E) and h602(E)**

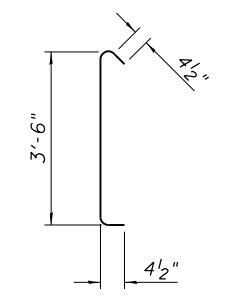

**BAR h103(E), h203(E),  
h303(E), h403(E),  
h503(E) and h603(E)**

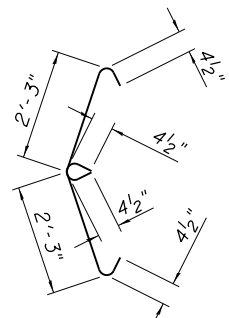

**BAR h104(E), h204(E),  
h304(E), h404(E),  
h504(E) and h604(E)**

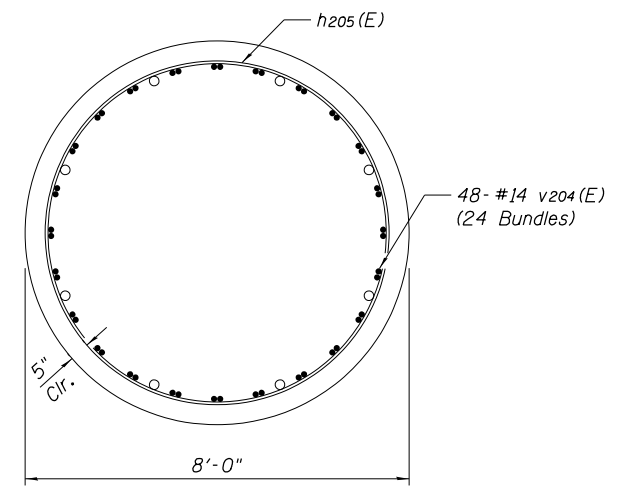

**G-G PILE SECTION**

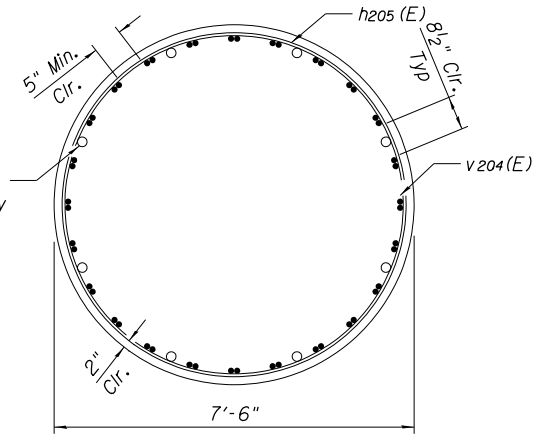

**H-H ROCK SOCKET**

**PIER 2 BILL OF MATERIAL**

Bar	No.	Size	Length	Shape
h201(E)	65	#5	15'-9"	□
h202(E)	86	#5	9'-7"	—
h203(E)	43	#5	4'-3"	—
h204(E)	86	#5	6'-0"	—
h205(E)	58	#7	22'-4"	○
v201(E)	32	#14	35'-3"	—
v202(E)	12	#14	35'-3"	—
v203(E) Min	14	#5	21'-3"	—
v203(E) Max	14	#5	21'-10"	—
v204(E)	48	#14	26'-5"	—
Concrete Structures			Cu. Yd.	20.7
Reinforcement Bars, Epoxy Coated			Pound	27,181
Drilled Shaft in Soil			Cu. Yd.	14.9
Drilled Shaft in Rock			Cu. Yd.	30.7
Permanent Casing			Foot	8.0
Crosshole Sonic Logging Testing			Each	1
Crosshole Sonic Logging Access Duct			Foot	27

- NOTES:
- For "F-F COLUMN SECTION" dimensions, "DETAIL A" and "SECTION D-D", see "PIER 1 DETAILS" sheet.
  - For Architectural treatment details and limits, see "ARCHITECTURAL DETAILS 4" sheet.
  - Temporary casing shall be removed after column concrete is set.



USER NAME = RSTONE	DESIGNED - E. Modarres	REVISED - -
	CHECKED - P. Frey	REVISED - -
PLOT SCALE = NO SCALE	DRAWN - I. Martin	REVISED - -
PLOT DATE = 10/19/2017	CHECKED - D. Fitzwilliam	REVISED - -

**STATE OF ILLINOIS  
DEPARTMENT OF TRANSPORTATION**

**PIER 2 DETAILS  
STRUCTURE NO. 045-P008**

SHEET NO. S-36 OF S-69 SHEETS

F.A.U. RT.E.	SECTION	COUNTY	TOTAL SHEETS	SHEET NO.
2503	16-00313-00-MS	KANE	254	197
		CONTRACT NO.		61E18

ILLINOIS FED. AID PROJECT

FILE NAME = 045P008-XXXX-037-PIER3DET.dgn

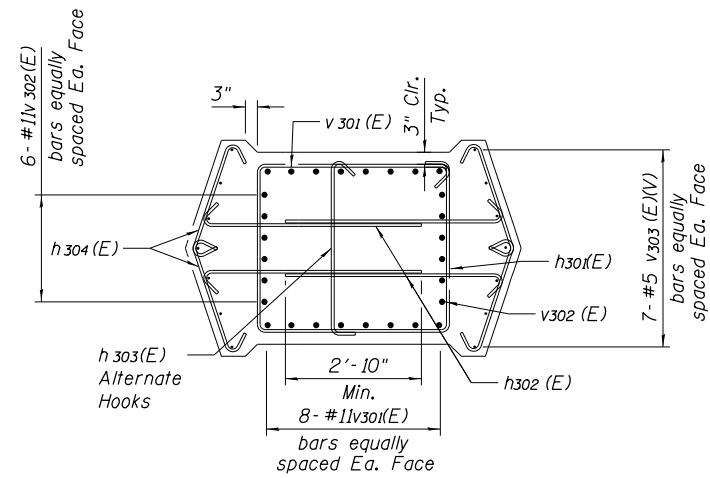
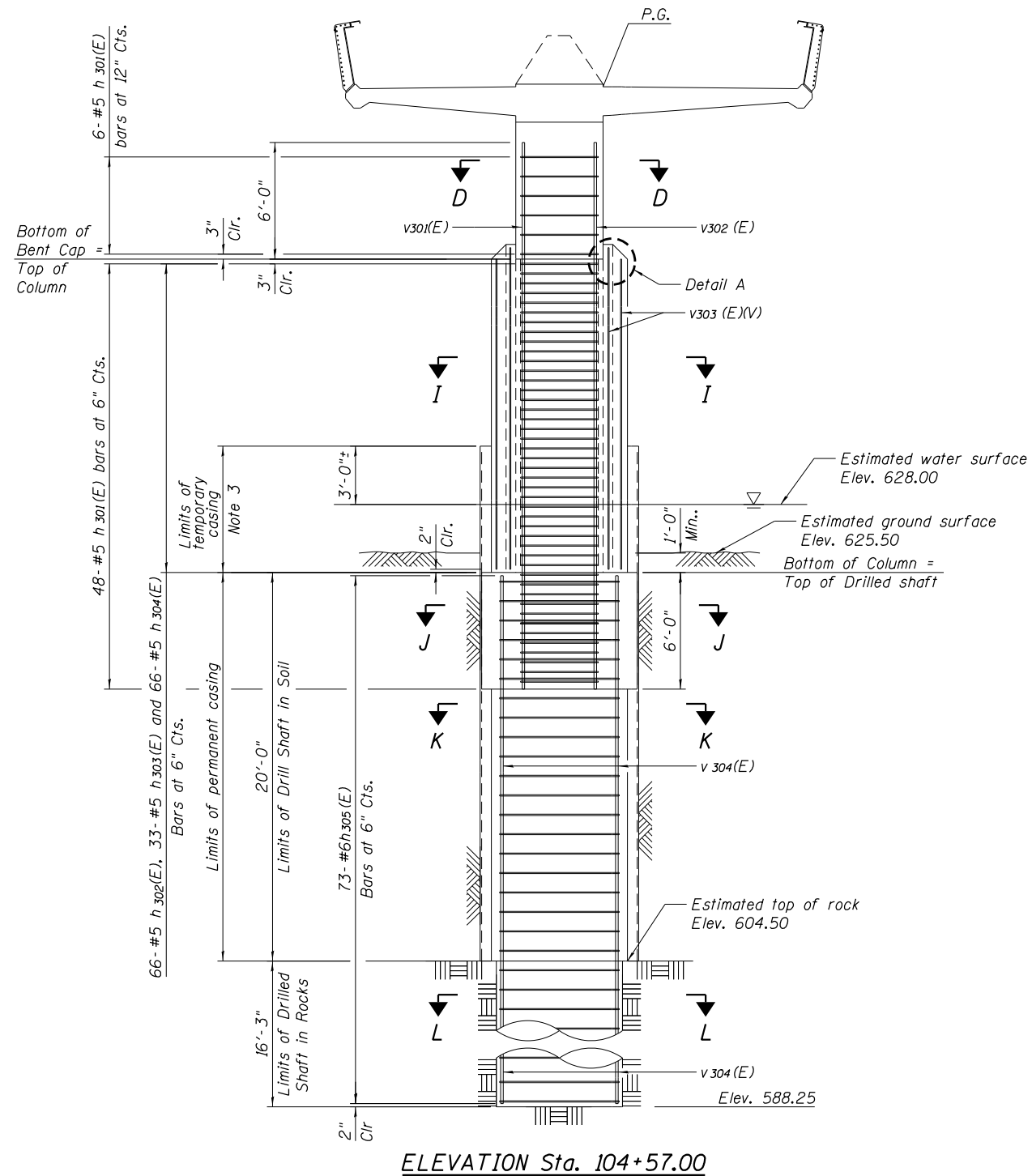

I-I COLUMN SECTION

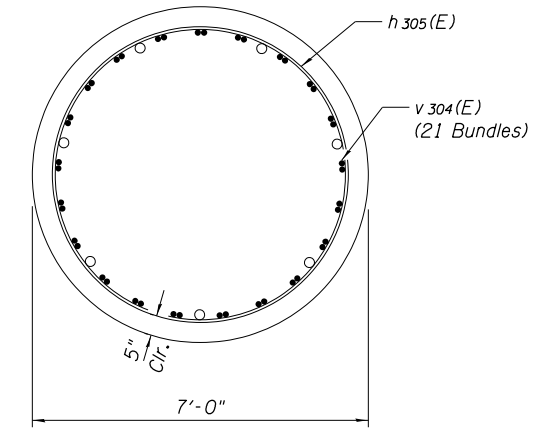

K-K LOWER PILE SECTION

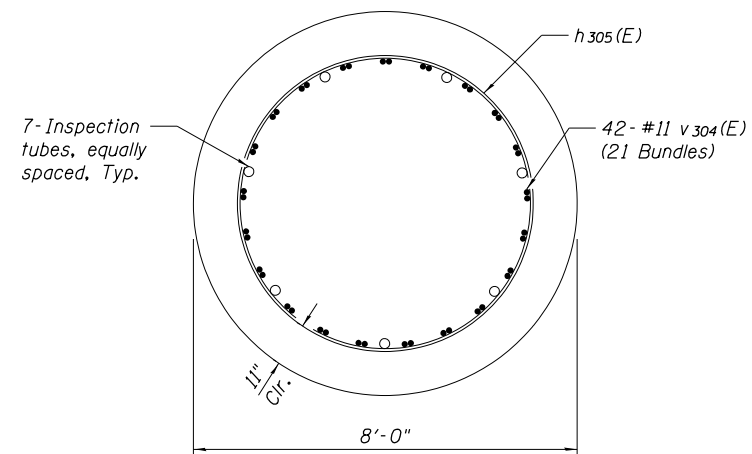

J-J UPPER PILE SECTION

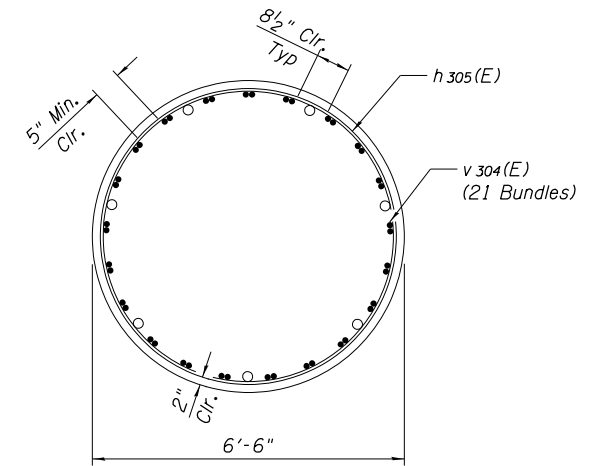

L-L ROCK SOCKET

NOTES:

- For "I-I COLUMN SECTION" dimensions, "DETAIL A" and "SECTION D-D", see "PIER 1 DETAILS" sheet.
- For Architectural treatment details and limits, see "ARCHITECTURAL DETAILS 4" sheet.
- Temporary casing shall be removed after column concrete is set.
- For bar shapes, see "PIER 2 DETAILS" sheet.

PIER 3 BILL OF MATERIAL

Bar	No.	Size	Length	Shape
h 301(E)	52	#5	15'-9"	□
h 302(E)	66	#5	9'-7"	U
h 303(E)	33	#5	4'-3"	U
h 304(E)	66	#5	6'-0"	U
h 305(E)	73	#6	19'-2"	○
v 301(E)	16	#11	28'-2"	—
v 302(E)	12	#11	28'-2"	—
v 303(E) Min	14	#5	16'-2"	—
v 303(E) Max	14	#5	16'-9"	—
v 304(E)	42	#11	35'-11"	—
Concrete Structures			Cu. Yd.	15.8
Reinforcement Bars, Epoxy Coated			Pound	16,617
Drilled Shaft in Soil			Cu. Yd.	31.1
Drilled Shaft in Rock			Cu. Yd.	20.0
Permanent Casing			Foot	20.0
Crosshole Sonic Logging Access Duct			Foot	36

TYLIN INTERNATIONAL

USER NAME = RSTONE	DESIGNED - E. Modarres	REVISED - -
PLOT SCALE = NO SCALE	CHECKED - P. Frey	REVISED - -
PLOT DATE = 10/19/2017	DRAWN - I. Martin	REVISED - -
	CHECKED - D. Fitzwilliam	REVISED - -

STATE OF ILLINOIS  
DEPARTMENT OF TRANSPORTATION

PIER 3 DETAILS  
STRUCTURE NO. 045-P008

SHEET NO. S-37 OF S-69 SHEETS

F.A.U. RTE.	SECTION	COUNTY	TOTAL SHEETS	SHEET NO.
2503	16-00313-00-MS	KANE	254	198
CONTRACT NO.			61E18	
ILLINOIS FED. AID PROJECT				

FILE NAME = 045P008-XXXX-038-PIER04DET.dgn

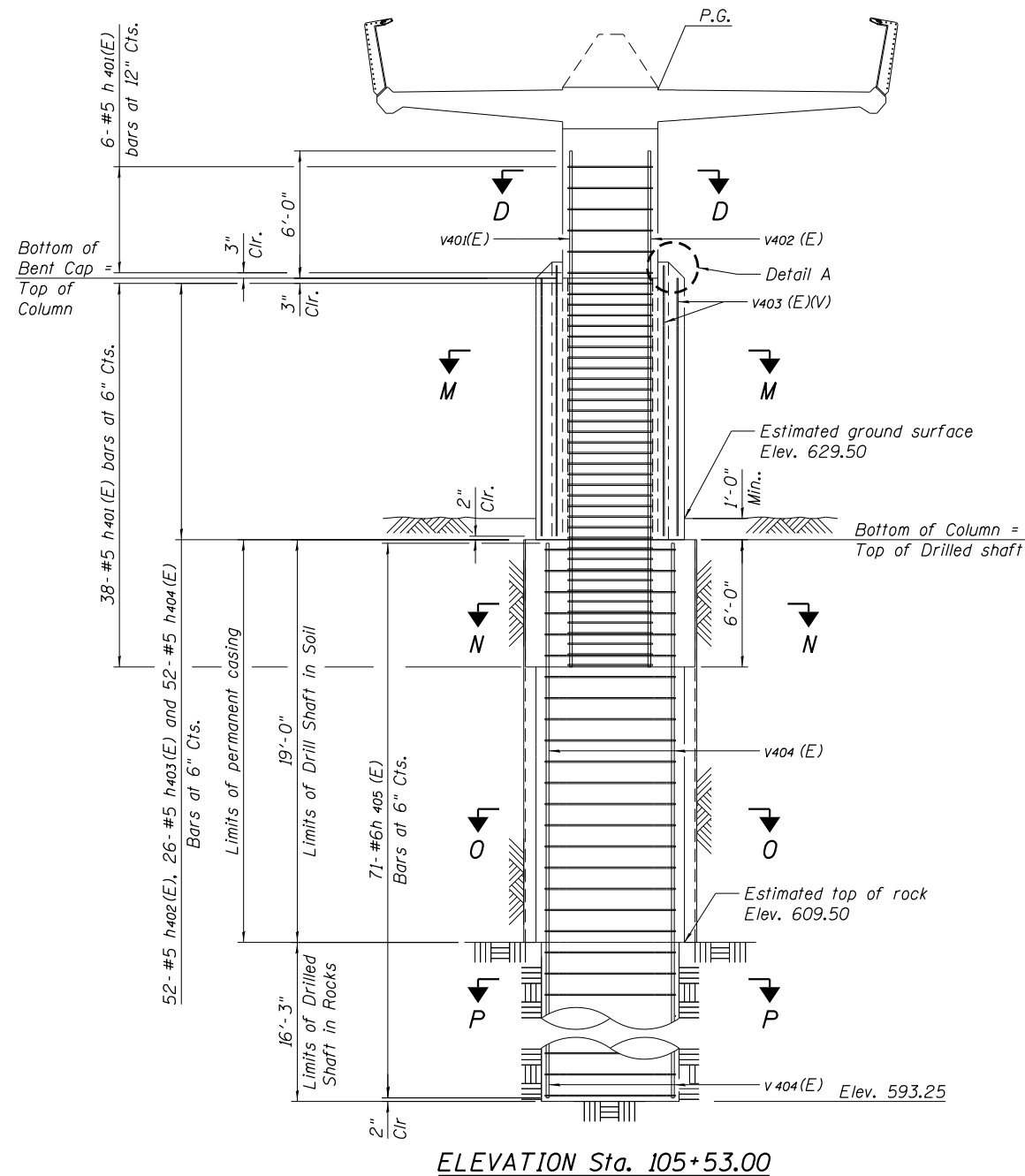

ELEVATION Sta. 105+53.00

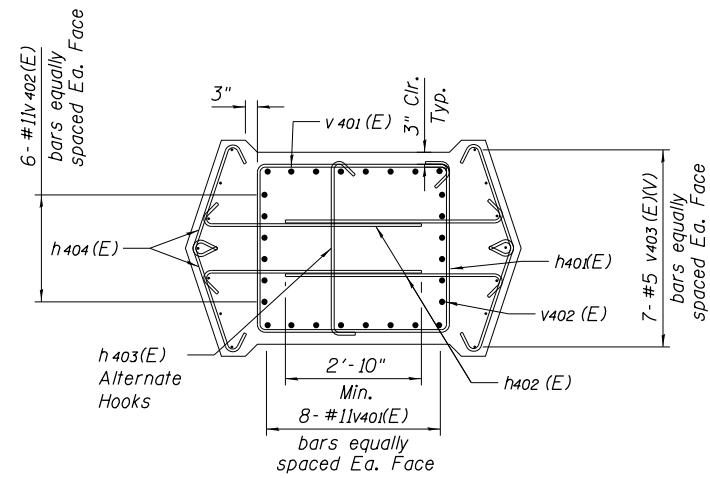

M-M COLUMN SECTION

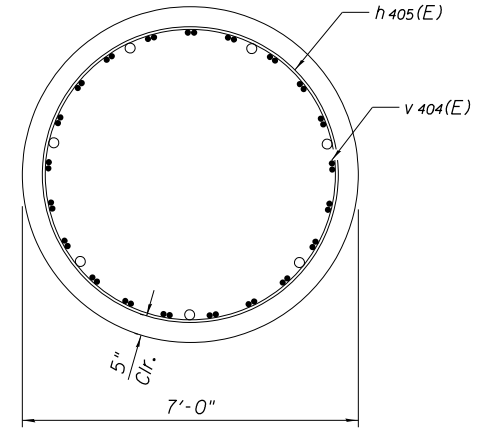

O-O LOWER PILE SECTION

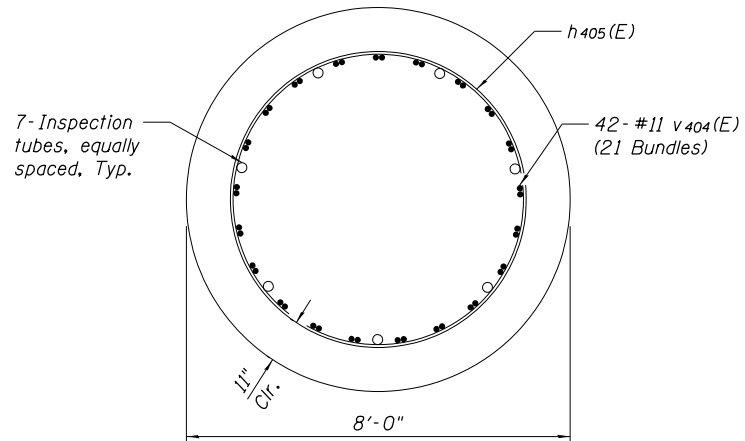

N-N UPPER PILE SECTION

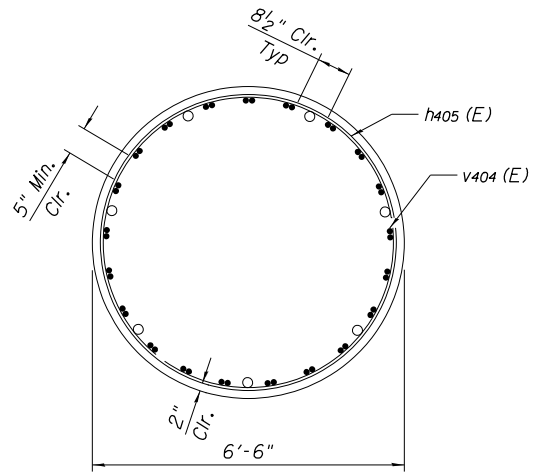

P-P ROCK SOCKET

- NOTES:
- For "M-M COLUMN SECTION" dimensions, "DETAIL A" "SECTION D-D", see "PIER 1 DETAILS" sheet.
  - For Architectural treatment details and limits, see "ARCHITECTURAL DETAILS 4" sheet.
  - For bar shapes, see "PIER 2 DETAILS" sheet.

PIER 4 BILL OF MATERIAL

Bar	No.	Size	Length	Shape
h401(E)	44	#5	15'-9"	□
h402(E)	52	#5	9'-7"	┌┐
h403(E)	26	#5	4'-3"	┌┐
h404(E)	52	#5	6'-0"	┌┐
h405(E)	71	#6	19'-2"	○
v401(E)	16	#11	24'-4"	—
v402(E)	12	#11	24'-4"	—
v403(E) Min	14	#5	12'-4"	—
v403(E) Max	14	#5	12'-11"	—
v404(E)	42	#11	34'-11"	—
Concrete Structures			Cu. Yd.	12.1
Reinforcement Bars, Epoxy Coated			Pound	15,319
Drilled Shaft in Soil			Cu. Yd.	29.7
Drilled Shaft in Rock			Cu. Yd.	20.0
Permanent Casing			Foot	19.0
Crosshole Sonic Logging Access Duct			Foot	35

TYLIN INTERNATIONAL

USER NAME = RSTONE	DESIGNED - E. Modarres	REVISED - -
PLOT SCALE = NO SCALE	CHECKED - P. Frey	REVISED - -
PLOT DATE = 10/19/2017	DRAWN - I. Martin	REVISED - -
	CHECKED - D. Fitzwilliam	REVISED - -

STATE OF ILLINOIS  
DEPARTMENT OF TRANSPORTATION

PIER 4 DETAILS  
STRUCTURE NO. 045-P008

SHEET NO. S-38 OF S-69 SHEETS

F.A.U. R.T.E.	SECTION	COUNTY	TOTAL SHEETS	SHEET NO.
2503	16-00313-00-MS	KANE	254	199
CONTRACT NO.			61E18	
ILLINOIS FED. AID PROJECT				

FILE NAME = 045P008-XXXX-039-PIER05DET.dgn

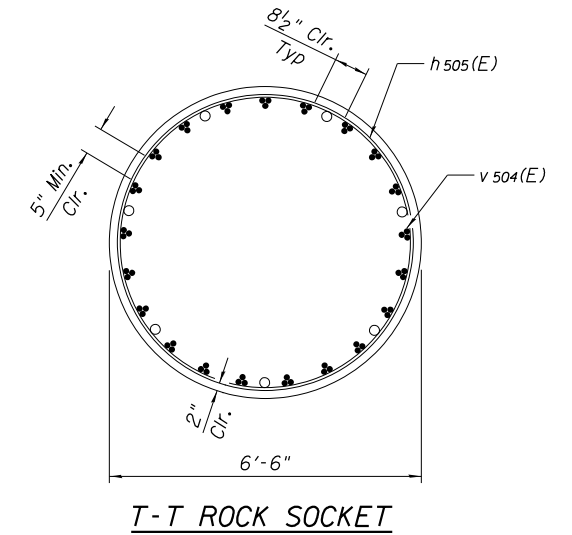
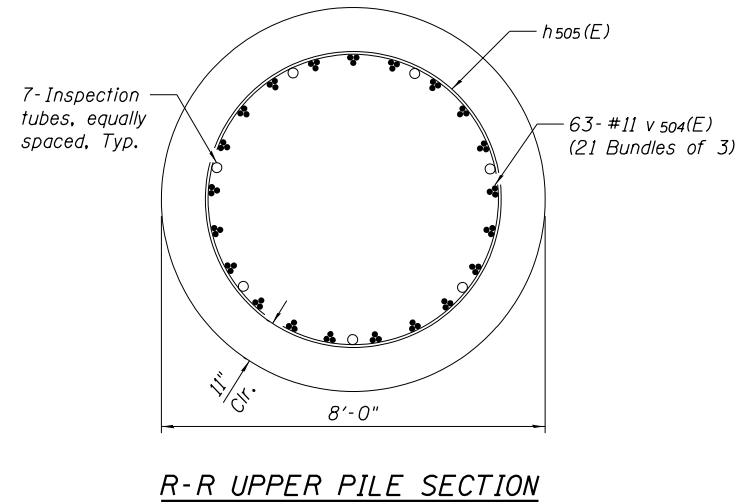
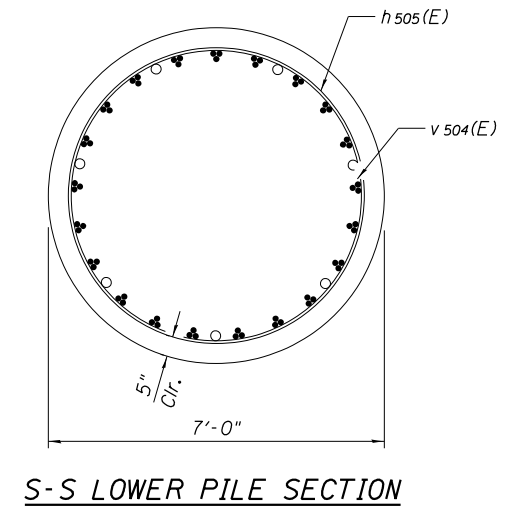
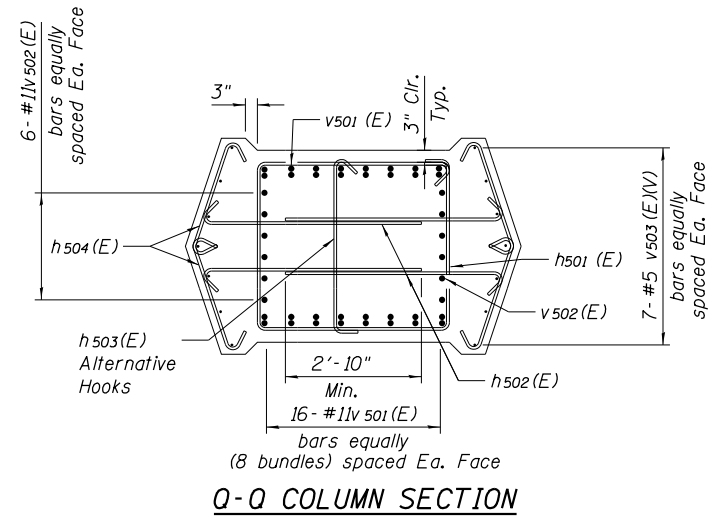
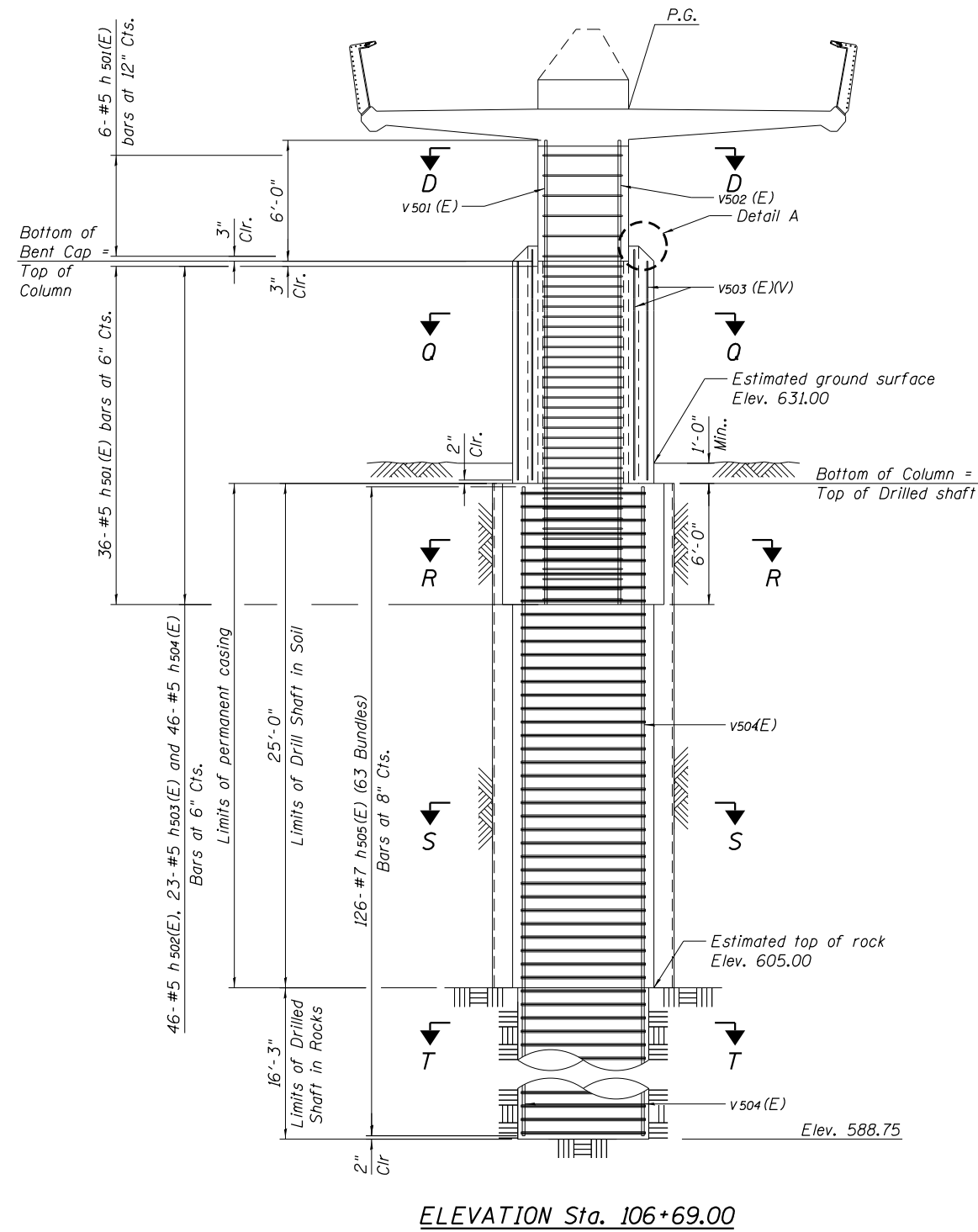

- NOTES:
- For "Q-Q COLUMN SECTION" dimensions, "DETAIL A" and "SECTION D-D", see "PIER 1 DETAILS" sheet.
  - For Architectural treatment details and limits, see "ARCHITECTURAL DETAILS 4" sheet.
  - For bar shapes, see "PIER 2 DETAILS" sheet.

**PIER 5 BILL OF MATERIAL**

Bar	No.	Size	Length	Shape
h501(E)	42	#5	15'-9"	□
h502(E)	46	#5	9'-7"	┌┐
h503(E)	23	#5	4'-3"	┌┐
h504(E)	46	#5	6'-0"	┌┐
h505(E)	126	#7	19'-2"	○
v501(E)	32	#11	23'-0"	—
v502(E)	12	#11	23'-0"	—
v503(E) Min	14	#5	11'-0"	—
v503(E) Max	14	#5	11'-7"	—
v504(E)	63	#11	40'-11"	—
Concrete Structures			Cu. Yd.	10.8
Reinforcement Bars, Epoxy Coated			Pound	25,710
Drilled Shaft in Soil			Cu. Yd.	38.3
Drilled Shaft in Rock			Cu. Yd.	20.0
Permanent Casing			Foot	25.0
Crosshole Sonic Logging Access Duct			Foot	41

TYLIN INTERNATIONAL	USER NAME = RSTONE	DESIGNED - E. Modarres	REVISED - -
	PLOT SCALE = NO SCALE	CHECKED - P. Frey	REVISED - -
	PLOT DATE = 10/19/2017	DRAWN - I. Martin	REVISED - -
		CHECKED - D. Fitzwilliam	REVISED - -

STATE OF ILLINOIS  
DEPARTMENT OF TRANSPORTATION

PIER 5 DETAILS  
STRUCTURE NO. 045-P008

SHEET NO. S-39 OF S-69 SHEETS

F.A.U. RT.E.	SECTION	COUNTY	TOTAL SHEETS	SHEET NO.
2503	16-00313-00-MS	KANE	254	200
CONTRACT NO.			61E18	
ILLINOIS FED. AID PROJECT				