

STATE OF ILLINOIS  
DEPARTMENT OF TRANSPORTATION

F.A.I. RTE.	SECTION	COUNTY	TOTAL SHEETS	SHEET NO.
74	[(72-30;48-29)HB-1]BRR	*	115*	1
		ILLINOIS	CONTRACT NO. 68D48	

\* 115 + 2 = 117 TOTAL SHEETS \* PEORIA & KNOX

INDEX OF SHEETS

- 1 COVER SHEET
- 2 GENERAL NOTES, LIST OF STANDARDS, & COMMITMENTS
- 3-10 SUMMARY OF QUANTITIES
- IL 78 PLANS
- 11-14 TYPICAL SECTIONS
- 15-18 SCHEDULE OF QUANTITIES
- 19 ALIGNMENT, TIES & BENCHMARKS
- 20-21 REMOVAL SHEETS
- 22-24 PLAN SHEETS
- 25 STAGING PLAN
- 26-29 EROSION CONTROL PLAN
- 30-54 STRUCTURE PLANS
- 55-56 MISCELLANEOUS DETAILS
- 57-62 DISTRICT DETAILS
- 63-71 CROSS SECTIONS
- CH 18 PLANS
- 72-75 TYPICAL SECTIONS
- 76-78 SCHEDULE OF QUANTITIES
- 79 ALIGNMENT, TIES & BENCHMARKS
- 80 REMOVAL SHEET
- 81-83 PLAN SHEETS
- 84 TRAFFIC CONTROL AND PROTECTION BLR 21
- 85-87 EROSION CONTROL PLAN
- 88-104 STRUCTURE PLANS
- 105-106 MISCELLANEOUS DETAILS
- 107-109 DISTRICT DETAILS
- 110-115 CROSS SECTIONS

PROPOSED  
HIGHWAY PLANS

FAI ROUTE 74 (I-74)  
SECTION [(72-30;48-29)HB-1]BRR  
PROJECT NHPP-TRH1(055)  
BRIDGE DECK REPLACEMENT  
PEORIA, KNOX COUNTY

C-94-027-17

FOR LIST OF HIGHWAY STANDARDS, SEE SHEET NO. 2

TRAFFIC DATA

IL 78 (S.N. 072-0032) CH 18 (S.N. 048-0035)  
2021 ADT = 550 2021 ADT = 300  
SU% = 7.27%  
MU% = 7.27%

FAI 74  
ADT = 15100  
SU% = 5.31%  
MU% = 27.48%

FUNCTIONAL CLASSIFICATION

IL 78: MAJOR COLLECTOR  
CH 18: MAJOR COLLECTOR  
FAI 74: INTERSTATE

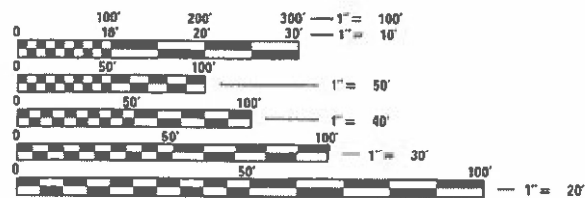

FULL SIZE PLANS HAVE BEEN PREPARED USING STANDARD ENGINEERING SCALES. REDUCED SIZED PLANS WILL NOT CONFORM TO STANDARD SCALES. IN MAKING MEASUREMENTS ON REDUCED PLANS, THE ABOVE SCALES MAY BE USED.

J.U.L.I.E.  
JOINT UTILITY LOCATION INFORMATION FOR EXCAVATION  
1-800-892-0123  
OR 811 TOWNSHIP(S): BRIMFIELD, ELBA

PROJECT ENGINEER: NICOLE FAYANT (309-671-3454)

PROJECT MANAGER: RON NOLTE (309-671-3470)

CATALOG NO. 033103-02D

CONTRACT NO. 68D48

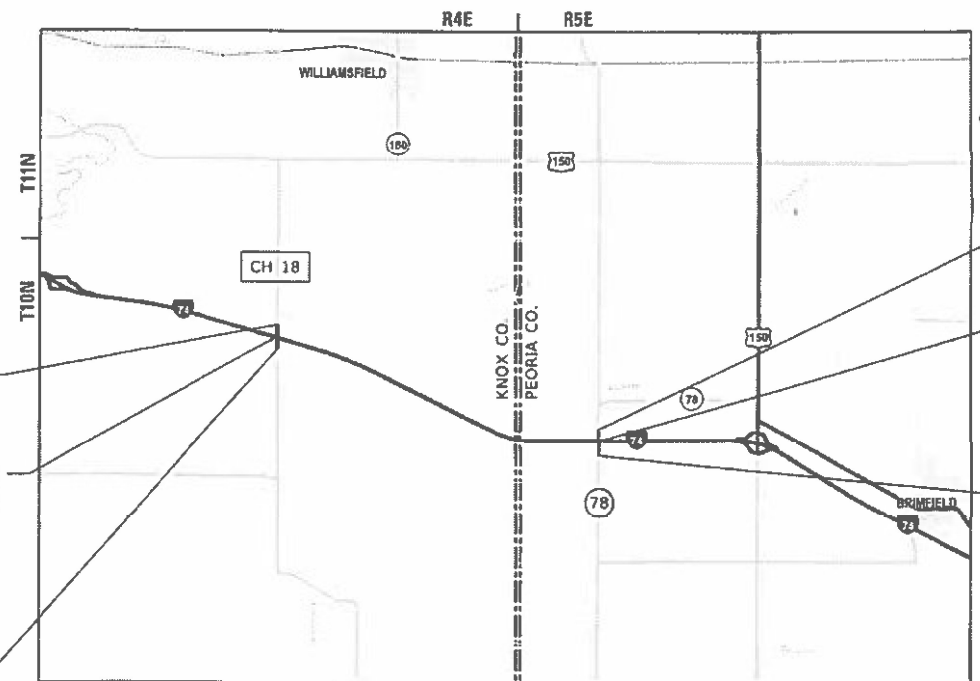

SCALE: 1" = 2.30 MI

GROSS LENGTH = 1029.81 FT. + 1991.52 FT. = 0.572 MILE

NET LENGTH = 245.50 FT. + 228.00 FT. = 0.090 MILE

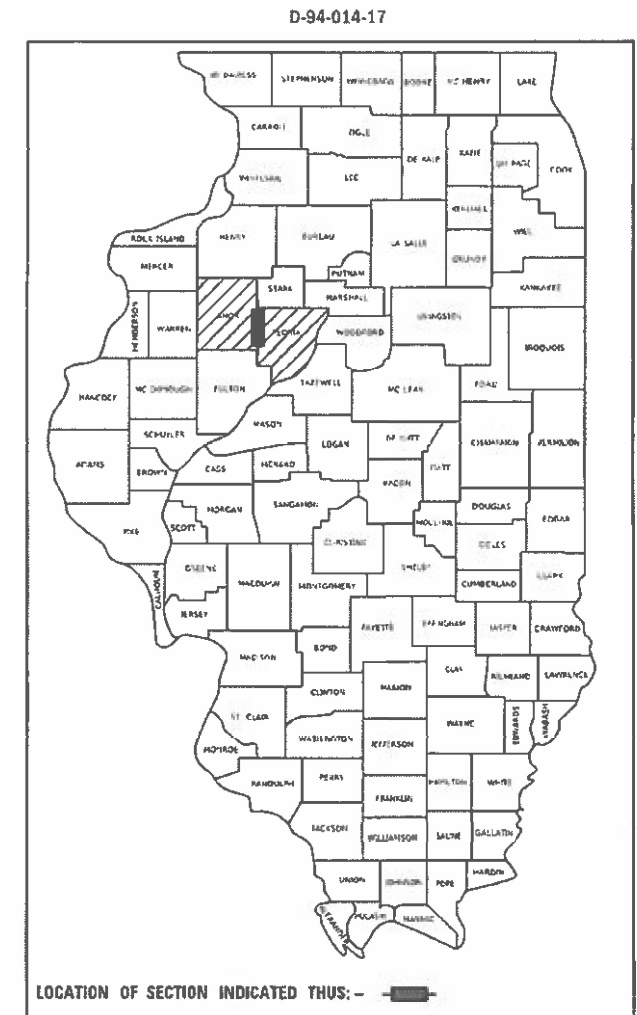

PLANS PREPARED BY:

4940 Old Collinsville Road  
Swansea, Illinois 62226  
Tel: 618.624.4488  
www.twm-inc.com

Illinois Professional Design Firm  
No. 184-001220  
License Expires: 04/30/2025  
ILLINOIS - MISSOURI - TENNESSEE

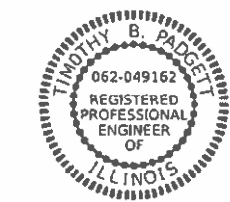

STATE OF ILLINOIS  
DEPARTMENT OF TRANSPORTATION

SUBMITTED Oct 19 2023  
Kensie A Barnett RSO  
REGIONAL ENGINEER  
December 8, 2023  
Steph M. Smith  
ENGINEER OF DESIGN AND ENVIRONMENT  
December 8, 2023  
Steph M. Smith  
DIRECTOR OF HIGHWAYS PROJECT IMPLEMENTATION

PRINTED BY THE AUTHORITY  
OF THE STATE OF ILLINOIS

TIMOTHY B. PADGETT, PE  
LICENSE NO. 062-049162 EXPIRATION DATE 11-30-2023  
SHEETS: 1-29, 55-87, 105-115

## DISTRICT 4 GENERAL NOTES

### AVAILABILITY OF ELECTRONIC FILES

MICROSTATION AND GEOPAK FILES OF THIS PROJECT WILL BE MADE AVAILABLE TO THE CONTRACTOR AFTER CONTRACT AWARD. IF THERE IS A CONFLICT BETWEEN THE ELECTRONIC FILES AND THE PRINTED CONTRACT PLANS AND DOCUMENTS, THE PRINTED CONTRACT PLANS AND DOCUMENTS SHALL TAKE PRECEDENCE OVER THE ELECTRONIC FILES. THE CONTRACTOR SHALL ACCEPT ALL RISK ASSOCIATED WITH USING THE ELECTRONIC FILES AND SHALL HOLD THE DEPARTMENT HARMLESS FOR ANY ERRORS OR OMISSIONS IN THE ELECTRONIC FILES AND THE DATA CONTAINED THEREIN. ERRORS OR DELAYS RESULTING FROM THE USE OF THE ELECTRONIC FILES BY THE CONTRACTOR SHALL NOT RESULT IN AN EXTENSION OF TIME FOR ANY INTERIM OR FINAL COMPLETION DATE OR SHALL NOT BE CONSIDERED CAUSE FOR ADDITIONAL COMPENSATION. THE CONTRACTOR SHALL NOT USE, SHARE, OR DISTRIBUTE THESE ELECTRONIC FILES EXCEPT FOR THE PURPOSE OF CONSTRUCTING THIS CONTRACT. ANY CLAIMS BY THIRD PARTIES DUE TO USE OR ERRORS SHALL BE THE SOLE RESPONSIBILITY OF THE CONTRACTOR. THE CONTRACTOR SHALL INCLUDE THIS DISCLAIMER WITH THE TRANSFER OF THESE ELECTRONIC FILES TO ANY OTHER PARTIES AND SHALL INCLUDE APPROPRIATE LANGUAGE BINDING THEM TO SIMILAR RESPONSIBILITIES.

### TREE REMOVAL - UTILITY RELOCATIONS

TREE REMOVAL MAY BE NECESSARY PRIOR TO UTILITY COMPANIES BEING ABLE TO RELOCATE THEIR FACILITIES OUTSIDE THE CONSTRUCTION LIMITS. THE CONTRACTOR SHOULD COORDINATE ANY CONTRACT TREE REMOVAL ACTIVITIES WITH THE UTILITY COMPANIES TO ELIMINATE CONFLICTS AND POTENTIAL DELAYS CAUSED BY UTILITY TREE REMOVAL ACTIVITIES OR INCOMPLETE UTILITY RELOCATIONS.

### PLAN ELEVATIONS - U.S.G.S. MEAN SEA LEVEL DATUM

ALL ELEVATIONS SHOWN ON THE PLANS ARE ESTABLISHED FROM U.S.G.S. MEAN SEA LEVEL DATUM.

### TREE REMOVAL RESTRICTIONS

DUE TO THE POTENTIAL PRESENCE OF ENDANGERED BATS, NO TREE REMOVAL WILL BE ALLOWED ON THIS PROJECT BETWEEN APRIL 1<sup>ST</sup> AND SEPTEMBER 30<sup>TH</sup>.

### ENVIRONMENTAL REVIEWS

PRIOR TO THE USE OF ANY PROPOSED BORROW AREAS, USE AREAS (TEMPORARY ACCESS ROADS, DETOURS, RUN-AROUNDS, ETC.) AND/OR WASTE AREAS, THE CONTRACTOR SHALL FILE THE REQUIRED ENVIRONMENTAL RESOURCE REQUEST SURVEYS ACCORDING TO SECTION 107.22 OF THE STANDARD SPECIFICATIONS. THESE SURVEYS ARE REQUIRED IN ORDER FOR THE DEPARTMENT TO CONDUCT CULTURAL AND BIOLOGICAL RESOURCE SURVEYS FOR THE PROPOSED SITE.

THE REQUIRED ENVIRONMENTAL RESOURCE DOCUMENTATION SHALL INCLUDE THE FOLLOWING:

- BDE FORM 2289 (BORROW SITE REVIEW)
- BDE FORM 2290 (WASTE/USE AREA REVIEW)
- A LOCATION MAP SHOWING THE SIZE LIMITS AND LOCATION OF THE USE AREA
- COLOR PHOTOGRAPHS DEPICTING THE USE AREA
- BORROW AREA ENTRY AGREEMENT FORM - D4 PI0101

PRIOR TO ANY WASTE MATERIALS BEING REMOVED FROM THE CONSTRUCTION SITE THE REQUIRED ENVIRONMENTAL RESOURCE SURVEYS SHALL BE OBTAINED AND FILED BY THE CONTRACTOR. EXCESS WASTE PRODUCTS REMOVED FROM THE CONSTRUCTION SITE SHALL BE DISPOSED OF AS REQUIRED IN SECTION 202.03 OF THE STANDARD SPECIFICATIONS.

ANY PROTRUDING METAL BARS SHALL BE REMOVED PRIOR TO THE DISPOSAL OF BROKEN CONCRETE AT APPROVED DISPOSAL SITES.

PLEASE NOTE THAT A MINIMUM OF FOUR WEEKS SHALL BE ALLOWED FOR THE DISTRICT TO OBTAIN THE REQUIRED WASTE SITE ENVIRONMENTAL CLEARANCES AND SIX WEEKS FOR THE REQUIRED BORROW SITE ENVIRONMENTAL CLEARANCES

### SEEDING - SIDESLOPE RIPPING

ALL SLOPES STEEPER THAN 3 TO 1 AND OVER 15 FT. (4.5 M) IN HEIGHT SHALL BE RIPPED. THIS SHALL CONSIST OF RIPPING BETWEEN 18 INCHES TO 24 INCHES (450 MM TO 600 MM) DEEP NORMAL TO THE SLOPE. THE INTERVAL OF RIPPING ALONG THE SLOPE SHALL BE 12 FT. (3.6 M). THIS WORK SHALL BE DONE AFTER THE SEED BED HAS BEEN PREPARED BUT BEFORE ANY FERTILIZER OR SEED HAS BEEN APPLIED. THE FERTILIZER AND SEED SHALL BE APPLIED WITHIN A 24-HOUR PERIOD AFTER THE RIPPING HAS BEEN DONE. THIS WORK WILL NOT BE PAID FOR SEPARATELY BUT WILL BE INCLUDED IN THE COST OF THE VARIOUS ITEMS OF SEEDING INVOLVED.

### BUTT JOINT CUTTING TIME RESTRICTION

BUTT JOINTS SHALL NOT BE MILLED MORE THAN THREE (3) DAYS PRIOR TO PLACEMENT OF THE HMA SURFACE COURSE.

### ORDERING LENGTH CONFIRMATION - DRAINAGE ITEMS

THE CONTRACTOR SHALL CONSULT WITH THE ENGINEER IN REGARD TO THE EXACT LENGTH OF THE BOX/PIPE CULVERTS, STORM SEWERS, AND/OR PIPE DRAINS REQUIRED PRIOR TO ORDERING THESE ITEMS

### NO PASSING ZONE VERIFICATION

THE RESIDENT SHALL CONTACT OPERATIONS TO VERIFY THE LOCATION OF NO PASSING ZONES PRIOR TO PLACEMENT OF CENTERLINE STRIPING.

## HIGHWAY STANDARDS

000001-08	STANDARD SYMBOLS, ABBREVIATIONS AND PATTERNS
001001-02	AREAS OF REINFORCEMENT BARS
001006	DECIMAL OF AN INCH AND OF A FOOT
420001-10	PAVEMENT JOINTS
420401-13	PAVEMENT CONNECTOR (PCC) FOR BRIDGE APPROACH SLAB
420701-03	PAVEMENT WELDED WIRE REINFORCEMENT
482001-02	HMA SHOULDER ADJACENT TO FLEXIBLE PAVEMENT
601101-02	CONCRETE HEADWALL FOR PIPE UNDERDRAINS
630001-13	STEEL PLATE BEAM GUARDRAIL
631031-18	TRAFFIC BARRIER TERMINAL, TYPE 6
701001-02	OFF-ROAD OPERATIONS, 2L, 2W, MORE THAN 15 FT AWAY
701006-05	OFF-ROAD OPERATIONS, 2L, 2W, 15 FT TO 24 IN FROM PAVEMENT EDGE
701011-04	OFF-ROAD MOVING OPERATIONS, 2L, 2W, DAY ONLY
701101-05	OFF-ROAD OPERATIONS, MULTILANE, 15 FT TO 24 IN FROM PAVEMENT EDGE
701106-02	OFF-ROAD OPERATIONS, MULTILANE, MORE THAN 15 FT AWAY
701301-04	LANE CLOSURE, 2L, 2W, SHORT TIME OPERATIONS
701306-04	LANE CLOSURE, 2L, 2W, SLOW MOVING OPERATIONS DAY ONLY, FOR SPEEDS 45 MPH OR MORE
701311-03	LANE CLOSURE, 2L, 2W, MOVING OPERATIONS - DAY ONLY
701321-18	LANE CLOSURE, 2L, 2W, BRIDGE REPAIR WITH BARRIER
701326-04	LANE CLOSURE, 2L, 2W, PAVEMENT WIDENING, FOR SPEEDS 45 MPH OR MORE
701400-12	APPROACH TO LANE CLOSURE, FREEWAY, DAY OPERATIONS ONLY
701401-13	LANE CLOSURE, FREEWAY/ EXPRESSWAY
701428-01	TRAFFIC CONTROL SETUP & REMOVAL FREEWAY/ EXPRESSWAY
701901-09	TRAFFIC CONTROL DEVICES
704001-08	TEMPORARY CONCRETE BARRIER
725001-01	OBJECT AND TERMINAL MARKERS
780001-05	TYPICAL PAVEMENT MARKINGS
782006-01	GUARDRAIL AND BARRIER WALL REFLECTOR MOUNTING DETAILS
BLR 21-9	TYPICAL APPLICATION OF TRAFFIC CONTROL DEVICES FOR CONSTRUCTION ON RURAL LOCAL HIGHWAYS

### COMMITMENTS

ALL COMMITMENTS ARE NOT TO BE ALTERED WITHOUT THE WRITTEN APPROVAL OF ALL PARTIES TO WHICH THE COMMITMENT WAS MADE.

NO COMMITMENTS HAVE BEEN MADE WITH ON THIS PROJECT.

## HOT-MIX ASPHALT MIXTURE REQUIREMENTS

LOCATION(S):	IL 78 MAINLINE	IL 78 SHOULDERS	IL 78 SHOULDERS	IL 78 SHOULDERS	CH 18 MAINLINE	CH 18 MAINLINE	CH 18 SHOULDERS
MIXTURE USE(S):	SURFACE 2"	BASE COURSE WIDENING 9"	HMA SHOULDERS 8"	HMA SHOULDERS 2"	SURFACE 1.5"	HMA BINDER 1.75"	HMA SHOULDERS 3.25"
AC/PG:	PG 58-28	PG 58-28	PG 58-28	PG 58-28	PG 58-28	PG 58-28	PG 58-28
DESIGN AIR VOIDS:	4.0% @ N=50	4.0% @ N=50	4.0% @ N=50	4.0% @ N=50	4.0% @ N=50	4.0% @ N=50	4.0% @ N=50
MIXTURE COMPOSITION (MIXTURE GRADATION):	IL 9.5	IL 19.0	IL 19.0	IL 9.5	IL 9.5	IL 9.5	IL 9.5
FRICTION AGGREGATE:	MIX D	N/A	N/A	N/A	MIX D	N/A	MIX D
QUALITY MANAGEMENT PROGRAM:	QCQA	QCQA	QCQA	QCQA	QCQA	QCQA	QCQA
MTD:	YES	NO	NO	NO	YES	NO	NO

STATE OF ILLINOIS  
DEPARTMENT OF TRANSPORTATION

GENERAL NOTES, HIGHWAY STANDARDS AND COMMITMENTS

SCALE: SHEET 1 OF 1 SHEETS STA. TO STA.

F.A.I. RTE.	SECTION	COUNTY	TOTAL SHEETS	SHEET NO.
74	[(72-30;48-29)HB-1]BRR	PEORIA & KNOX	115	2
CONTRACT NO. 68D48				
ILLINOIS		FED. AID PROJECT		

MODEL Path: H:\PROJECTS\2022\20221122\NC - IL 78 over FAI 74 & CH 184 CAD.DWG\47\_Trim\CAD\_Sheets\184BDD18.ctb:general.dgn



**TWM, INC.**  
www.twm-inc.com  
IL DESIGN FIRM  
LICENSE NO:  
184-001220

USER NAME = bbillhartz	DESIGNED -	REVISED -
PLOT SCALE = 20,0000 * / in.	DRAWN -	REVISED -
PLOT DATE = 10/4/2023	CHECKED -	REVISED -
	DATE -	REVISED -



CODE NO.	PAY ITEM	UNIT	TOTAL QUANTITY	FAP 22 (IL 78)	FAP 22 (IL 78)	FAP 398 (CH 18)	FAP 398 (CH 18)
				S.N. 072-0032	PEORIA COUNTY	S.N. 048-0035	KNOX COUNTY
				90% FEDERAL / 10% STATE	90% FEDERAL / 10% STATE	90% FEDERAL / 10% STATE	90% FEDERAL / 10% STATE
				0013 BRIDGE	0004 ROADWAY	0013 BRIDGE	0004 ROADWAY
				RURAL	RURAL	RURAL	RURAL
28000400	PERIMETER EROSION BARRIER	FOOT	5762		4031		1731
28000500	INLET AND PIPE PROTECTION	EACH	3		2		1
28200200	FILTER FABRIC	SQ YD	206		195		11
31100500	SUBBASE GRANULAR MATERIAL, TYPE A 6"	SQ YD	136		136		
31101900	SUBBASE GRANULAR MATERIAL, TYPE C	TON	48		48		
35101000	AGGREGATE BASE COURSE, TYPE A 11"	SQ YD	337				337
35650400	BASE COURSE WIDENING 9"	SQ YD	402		402		
40600275	BITUMINOUS MATERIALS (PRIME COAT)	POUND	673				673
40600290	BITUMINOUS MATERIALS (TACK COAT)	POUND	410		344		66
40600982	HOT-MIX ASPHALT SURFACE REMOVAL - BUTT JOINT	SQ YD	363		363		
40600990	TEMPORARY RAMP	SQ YD	119		119		
40602978	HOT-MIX ASPHALT BINDER COURSE, IL- 9.5, N50	TON	28				28
40604060	HOT-MIX ASPHALT SURFACE COURSE, IL-9.5, MIX "D", N50	TON	55		30		25
42000060	WELDED WIRE REINFORCEMENT	SQ YD	96		96		

MODEL Path: \\...  
 FILE NAME: P:\2021\2112\12-IL-78-over-FA-74 & Ch. 1B4-CADD-DWG\4.7-Trim\CAD\_Sheets\1\468D48-sh-500.dgn



USER NAME = bbillhartz	DESIGNED -	REVISED -
WWW.TWM-INC.COM	DRAWN -	REVISED -
PLOT SCALE = 40,0000 * / in.	CHECKED -	REVISED -
PLOT DATE = 10/16/2023	DATE -	REVISED -

**STATE OF ILLINOIS  
DEPARTMENT OF TRANSPORTATION**

**SUMMARY OF QUANTITIES**

SCALE: SHEET 2 OF 8 SHEETS STA. TO STA.

F.A.I. RTE.	SECTION	COUNTY	TOTAL SHEETS	SHEET NO.
74	[(72-30;48-29)HB-1]BRR	PEORIA & KNOX	115	4
CONTRACT NO. 68D48				
ILLINOIS FED. AID PROJECT				

CODE NO.	PAY ITEM	UNIT	TOTAL QUANTITY	FAP 22 (IL 78)	FAP 22 (IL 78)	FAP 398 (CH 18)	FAP 398 (CH 18)
				S.N. 072-0032	S.N. 072-0032	S.N. 048-0035	S.N. 048-0035
				PEORIA COUNTY	PEORIA COUNTY	KNOX COUNTY	KNOX COUNTY
				90% FEDERAL / 10% STATE	90% FEDERAL / 10% STATE	90% FEDERAL / 10% STATE	90% FEDERAL / 10% STATE
				0013 BRIDGE	0004 ROADWAY	0013 BRIDGE	0004 ROADWAY
RURAL	RURAL	RURAL	RURAL				
42000080	PAVEMENT CONNECTOR (PCC) FOR BRIDGE APPROACH SLAB	SQ YD	53		53		
44000100	PAVEMENT REMOVAL	SQ YD	386		386		
44004250	PAVED SHOULDER REMOVAL	SQ YD	276		276		
48101200	AGGREGATE SHOULDERS, TYPE B	TON	155		48		107
48101600	AGGREGATE SHOULDERS, TYPE B 8"	SQ YD	75				75
48102100	AGGREGATE WEDGE SHOULDER, TYPE B	TON	35		35		
48203005	HOT-MIX ASPHALT SHOULDERS, 2"	SQ YD	101		101		
48203010	HOT-MIX ASPHALT SHOULDERS, 3 1/4"	SQ YD	42				42
48203029	HOT-MIX ASPHALT SHOULDERS, 8"	SQ YD	2847		2847		
50102400	CONCRETE REMOVAL	CU YD	56.4	39.3		17.1	
50104650	SLOPE WALL REMOVAL	SQ YD	788	410		378	
50104701	REMOVAL OF EXISTING CONCRETE DECK NO. 1	EACH	1	1			
50104702	REMOVAL OF EXISTING DECK NO. 2	EACH	1			1	
50105220	PIPE CULVERT REMOVAL	FOOT	3				3
50157300	PROTECTIVE SHIELD	SQ YD	1091	564		527	

MODEL Path: H: FILE NAME: P:\2021\211221\IC - IL 78 over FA 74 & CH 184 CADD - DWG\47 FromCAD\_Sheet1(468D48).shx=500.dgn



**TWM, INC.**  
www.twm-inc.com  
IL DESIGN FIRM  
LICENSE NO:  
184-001220

USER NAME = bbillhartz  
PLOT SCALE = 40,0000 \* / in.  
PLOT DATE = 10/16/2023

DESIGNED -  
DRAWN -  
CHECKED -  
DATE -

REVISED -  
REVISED -  
REVISED -  
REVISED -

**STATE OF ILLINOIS  
DEPARTMENT OF TRANSPORTATION**

**SUMMARY OF QUANTITIES**

SCALE: SHEET 3 OF 8 SHEETS STA. TO STA.

F.A.I. RTE.	SECTION	COUNTY	TOTAL SHEETS	SHEET NO.
74	[(72-30;48-29)HB-1]BRR	PEORIA & KNOX	115	5
CONTRACT NO. 68D48				
ILLINOIS		FED. AID PROJECT		

CODE NO.	PAY ITEM	UNIT	TOTAL QUANTITY	FAP 22 (IL 78)	FAP 22 (IL 78)	FAP 398 (CH 18)	FAP 398 (CH 18)
				S.N. 072-0032		S.N. 048-0035	
				PEORIA COUNTY	PEORIA COUNTY	KNOX COUNTY	KNOX COUNTY
				90% FEDERAL / 10% STATE	90% FEDERAL / 10% STATE	90% FEDERAL / 10% STATE	90% FEDERAL / 10% STATE
				0013 BRIDGE	0004 ROADWAY	0013 BRIDGE	0004 ROADWAY
RURAL	RURAL	RURAL	RURAL				
50200100	STRUCTURE EXCAVATION	CU YD	281	172		109	
50300100	FLOOR DRAINS	EACH	8	8			
50300225	CONCRETE STRUCTURES	CU YD	46.0	30.6		15.4	
50300255	CONCRETE SUPERSTRUCTURE	CU YD	590.8	314.5		276.3	
50300260	BRIDGE DECK GROOVING	SQ YD	1670	952		718	
50300300	PROTECTIVE COAT	SQ YD	2269	1255		1014	
50301350	CONCRETE SUPERSTRUCTURE (APPROACH SLAB)	CU YD	94.6	94.6			
50500405	FURNISHING AND ERECTING STRUCTURAL STEEL	POUND	6240	4700		1540	
50500505	STUD SHEAR CONNECTORS	EACH	7233	3888		3345	
50800105	REINFORCEMENT BARS	POUND	23				23
50800205	REINFORCEMENT BARS, EPOXY COATED	POUND	186180	113250		72930	
50800515	BAR SPLICERS	EACH	993	993			
51100100	SLOPE WALL 4 INCH	SQ YD	772	362		410	
51500100	NAME PLATES	EACH	4	2		2	

MODEL Path: R:\2023\20231122\112112\112112112\112112112\112112112\112112112.dwg - Il. 78 over FA 74 & Ch. 1B4 CADD - DWG\4.7 FromCAD\_Sheets\112112112.dwg



**TWM, INC.**  
www.twm-inc.com  
ILL. DESIGN FIRM LICENSE NO: 184-001220

USER NAME = bbillhartz	DESIGNED -	REVISED -
PLOT SCALE = 40,0000 * / in.	DRAWN -	REVISED -
PLOT DATE = 10/16/2023	CHECKED -	REVISED -
	DATE -	REVISED -

**STATE OF ILLINOIS  
DEPARTMENT OF TRANSPORTATION**

<b>SUMMARY OF QUANTITIES</b>			
SCALE:	SHEET 4	OF 8	SHEETS
	STA.		TO STA.

F.A.I. RTE.	SECTION	COUNTY	TOTAL SHEETS	SHEET NO.
74	[(72-30;48-29)HB-1]BRR	PEORIA & KNOX	115	6
		CONTRACT NO. 68D48		
		ILLINOIS FED. AID PROJECT		

MODEL Path: H:\PROJECTS\2022\20221122\IC - IL 78 over FAI 74 & CH 1B4 CADD - DWG\4.7 Item\CAD\_Sheets\1468D48-sh-500.dgn  
 FILE NAME: P:\2022\20221122\IC - IL 78 over FAI 74 & CH 1B4 CADD - DWG\4.7 Item\CAD\_Sheets\1468D48-sh-500.dgn

CODE NO.	PAY ITEM	UNIT	TOTAL QUANTITY	FAP 22 (IL 78)	FAP 22 (IL 78)	FAP 398 (CH 18)	FAP 398 (CH 18)
				S.N. 072-0032	S.N. 072-0032	S.N. 048-0035	S.N. 048-0035
				PEORIA COUNTY	PEORIA COUNTY	KNOX COUNTY	KNOX COUNTY
				90% FEDERAL / 10% STATE	90% FEDERAL / 10% STATE	90% FEDERAL / 10% STATE	90% FEDERAL / 10% STATE
				0013 BRIDGE	0004 ROADWAY	0013 BRIDGE	0004 ROADWAY
RURAL	RURAL	RURAL	RURAL				
52100010	ELASTOMERIC BEARING ASSEMBLY, TYPE I	EACH	34	24		10	
52100505	ANCHOR BOLTS, 5/8"	EACH	88	48		40	
52100520	ANCHOR BOLTS, 1"	EACH	24	24			
52200010	TEMPORARY SHEET PILING	SQ FT	513	513			
54213445	END SECTIONS 10"	EACH	1				1
54248510	CONCRETE COLLAR	CU YD	0.2				0.2
542D0215	PIPE CULVERTS, CLASS D, TYPE 1 10"	FOOT	4				4
58600101	GRANULAR BACKFILL FOR STRUCTURES	CU YD	245	151		94	
59100100	GEOCOMPOSITE WALL DRAIN	SQ YD	130	77		53	
60100060	CONCRETE HEADWALLS FOR PIPE DRAINS	EACH	8	4		4	
60146304	PIPE UNDERDRAINS FOR STRUCTURES 4"	FOOT	270	143		127	
* 63000001	STEEL PLATE BEAM GUARDRAIL, TYPE A, 6 FOOT POSTS	FOOT	3500		2750		750
* 63100085	TRAFFIC BARRIER TERMINAL, TYPE 6	EACH	8		4		4
* 63100167	TRAFFIC BARRIER TERMINAL, TYPE 1 (SPECIAL) TANGENT	EACH	8		4		4

\*= SPECIALTY ITEM



**TWM, INC.**  
 www.twm-inc.com  
 IL DESIGN FIRM LICENSE NO: 184-001220

USER NAME = bbillhartz  
 PLOT SCALE = 40,0000 \* / in.  
 PLOT DATE = 10/16/2023

DESIGNED -  
 DRAWN -  
 CHECKED -  
 DATE -

REVISED -  
 REVISED -  
 REVISED -  
 REVISED -

**STATE OF ILLINOIS  
 DEPARTMENT OF TRANSPORTATION**

SUMMARY OF QUANTITIES			
SCALE:	SHEET 5 OF 8 SHEETS	STA.	TO STA.

F.A.I. RTE.	SECTION	COUNTY	TOTAL SHEETS	SHEET NO.
74	[(72-30;48-29)HB-1]BRR	PEORIA & KNOX	115	7
				CONTRACT NO. 68D48
ILLINOIS FED. AID PROJECT				

CODE NO.	PAY ITEM	UNIT	TOTAL QUANTITY	FAP 22 (IL 78)	FAP 22 (IL 78)	FAP 398 (CH 18)	FAP 398 (CH 18)
				S.N. 072-0032		S.N. 048-0035	
				PEORIA COUNTY	PEORIA COUNTY	KNOX COUNTY	KNOX COUNTY
				90% FEDERAL / 10% STATE	90% FEDERAL / 10% STATE	90% FEDERAL / 10% STATE	90% FEDERAL / 10% STATE
				0013 BRIDGE	0004 ROADWAY	0013 BRIDGE	0004 ROADWAY
	RURAL	RURAL	RURAL	RURAL			
63200310	GUARDRAIL REMOVAL	FOOT	4199		3063		1136
66500105	WOVEN WIRE FENCE, 4'	FOOT	425		221		204
* 66700205	PERMANENT SURVEY MARKERS, TYPE I	EACH	2	1		1	
67000400	ENGINEER'S FIELD OFFICE, TYPE A	CAL MO	9		4,5		4,5
67100100	MOBILIZATION	L SUM	1		0,5		0,5
70100405	TRAFFIC CONTROL AND PROTECTION, STANDARD 701321	EACH	1		1		
70100460	TRAFFIC CONTROL AND PROTECTION, STANDARD 701306	L SUM	1		0,5		0,5
70100500	TRAFFIC CONTROL AND PROTECTION, STANDARD 701326	L SUM	1		1		
70100800	TRAFFIC CONTROL AND PROTECTION, STANDARD 701401	L SUM	1		0,5		0,5
70103815	TRAFFIC CONTROL SURVEILLANCE	CAL DA	6		6		
70106500	TEMPORARY BRIDGE TRAFFIC SIGNALS	EACH	1		1		
70106700	TEMPORARY RUMBLE STRIPS	EACH	6		6		
70107005	PAVEMENT MARKING BLACKOUT TAPE, 5"	FOOT	1787		1787		
70107025	CHANGEABLE MESSAGE SIGN	CAL DA	112		56		56

\*= SPECIALTY ITEM

MODEL: D:\dtd\p11\112121\IC - IL 78 over FA1 74 & CH 1B4 CADD - DWG\4.7 FromCAD\_Sheets\1\468048.rvt-500.dgn  
 FILE NAME: P11202102112121\IC - IL 78 over FA1 74 & CH 1B4 CADD - DWG\4.7 FromCAD\_Sheets\1\468048.rvt-500.dgn



**TWM, INC.**  
 WWW.TWM-INC.COM  
 IL DESIGN FIRM  
 LICENSE NO:  
 184-001220

USER NAME = bbillhartz  
 PLOT SCALE = 40,0000 \* / in.  
 PLOT DATE = 10/16/2023

DESIGNED -  
 DRAWN -  
 CHECKED -  
 DATE -

REVISED -  
 REVISED -  
 REVISED -  
 REVISED -

**STATE OF ILLINOIS  
 DEPARTMENT OF TRANSPORTATION**

**SUMMARY OF QUANTITIES**

SCALE: SHEET 6 OF 8 SHEETS STA. TO STA.

F.A.I. RTE.	SECTION	COUNTY	TOTAL SHEETS	SHEET NO.
74	[(72-30;48-29)HB-1]BRR	PEORIA & KNOX	115	8
CONTRACT NO. 68D48			ILLINOIS FED. AID PROJECT	



CODE NO.	PAY ITEM	UNIT	TOTAL QUANTITY	FAP 22 (IL 78)	FAP 22 (IL 78)	FAP 398 (CH 18)	FAP 398 (CH 18)
				S.N. 072-0032		S.N. 048-0035	
				PEORIA COUNTY	PEORIA COUNTY	KNOX COUNTY	KNOX COUNTY
				90% FEDERAL / 10% STATE	90% FEDERAL / 10% STATE	90% FEDERAL / 10% STATE	90% FEDERAL / 10% STATE
				0013 BRIDGE	0004 ROADWAY	0013 BRIDGE	0004 ROADWAY
				RURAL	RURAL	RURAL	RURAL
70300100	SHORT TERM PAVEMENT MARKING	FOOT	107		107		
70300150	SHORT TERM PAVEMENT MARKING REMOVAL	SQ FT	777		777		
70300221	TEMPORARY PAVEMENT MARKING - LINE 4"- PAINT	FOOT	4848		4848		
70400100	TEMPORARY CONCRETE BARRIER	FOOT	582		582		
70400125	PINNING TEMPORARY CONCRETE BARRIER	EACH	99		99		
70400200	RELOCATE TEMPORARY CONCRETE BARRIER	FOOT	582		582		
70600260	IMPACT ATTENUATORS, TEMPORARY (FULLY REDIRECTIVE, NARROW), TEST LEVEL 3	EACH	2		2		
70600332	IMPACT ATTENUATORS, RELOCATE (FULLY REDIRECTIVE, NARROW), TEST LEVEL 3	EACH	2		2		
* 72501000	TERMINAL MARKER - DIRECT APPLIED	EACH	8		4		4
* 78009004	MODIFIED URETHANE PAVEMENT MARKING - LINE 4"	FOOT	4452		4452		
* 78200011	BARRIER WALL REFLECTORS, TYPE C	EACH	16		8		8
78300202	PAVEMENT MARKING REMOVAL - WATER BLASTING	SQ FT	1484		1484		
X4060107	BITUMINOUS MATERIALS (FOG SEAL)	POUND	712				712
X1500005	BITUMINOUS SURFACE TREATMENT, A2	SQ YD	1583				1583

\*= SPECIALTY ITEM

MODEL: Dwg.tbl  
 FILE NAME: P:\2023\112122\112122\112122\CAD - DWG\47 - From CAD - Sheet1(D468D48) - sht - 500.dgn



**TWM, INC.**  
 WWW.TWM-INC.COM  
 IL DESIGN FIRM LICENSE NO: 184-001220

USER NAME =	bbillhartz
PLOT SCALE =	40,0000 * / in.
PLOT DATE =	10/16/2023

DESIGNED -	
DRAWN -	
CHECKED -	
DATE -	

REVISED -	
REVISED -	
REVISED -	
REVISED -	

**STATE OF ILLINOIS  
 DEPARTMENT OF TRANSPORTATION**

**SUMMARY OF QUANTITIES**

SCALE: SHEET 7 OF 8 SHEETS STA. TO STA.

F.A.I. RTE.	SECTION	COUNTY	TOTAL SHEETS	SHEET NO.
74	[(72-30;48-29)HB-1]BRR	PEORIA & KNOX	115	9
CONTRACT NO. 68D48				
ILLINOIS FED. AID PROJECT				



**LEGEND**

LEGEND ITEMS IN LIGHT SHADED TEXT ARE FOR THE CH 18 STRUCTURE

- (A) EX. EMBANKMENT
  - (B) EX. TOP SOIL, 4"
  - (C) EX. SUBBASE GRANULAR MATERIAL, 4" AND VARIES
  - (D) EX. HMA
  - (E) EX. BAM, 8"
  - (F) EX. AGGREGATE SHOULDERS
  - (G) EX. GUARDRAIL
  - (H) EX. HMA SHOULDERS, 8"
  - (I) EX. OIL & CHIP
  - (J) EX. AGGREGATE BASE COURSE
- 
- ① PR. HMA SURFACE REMOVAL - BUTT JOINT
  - ② PR. HMA SURFACE COURSE, IL-9.5, MIX "D", N50, 1.5"
  - ③ PR. HMA SURFACE COURSE, IL-9.5, MIX "D", N50, 2"
  - ④ PR. HMA BINDER COURSE, IL-9.5, N50, 1.75"
  - ⑤ PR. HMA SURFACE REMOVAL (SPECIAL)
  - ⑥ PR. BITUMINOUS SURFACE TREATMENT, A2
  - ⑦ PR. BITUMINOUS MATERIALS (FOG SEAL)
  - ⑧ PR. HMA SHOULDERS, 2"
  - ⑨ PR. HMA SHOULDERS, 3.25"
  - ⑩ PR. AGGREGATE WEDGE SHOULDER, TYPE B
  - ⑪ PR. AGGREGATE SHOULDERS, TYPE B 8"
  - ⑫ PR. PAVEMENT REMOVAL
  - ⑬ PR. BASE COURSE WIDENING, 9"
  - ⑭ PR. AGGREGATE BASE COURSE TYPE A, 11"
  - ⑮ PR. STEEL PLATE BEAM GUARDRAIL, TYPE A, 6 FOOT POSTS
  - ⑯ PR. GUARDRAIL AGGREGATE EROSION CONTROL
  - ⑰ PR. CURB AND GUTTER (SPECIAL)
  - ⑱ PR. MODIFIED URETHANE PAVEMENT MARKING - LINE 4"
  - ⑲ PR. EMBANKMENT
  - ⑳ PR. PARALLEL WINGWALL (SEE BRIDGE PLANS)
  - ㉑ PR. HMA SHOULDERS, 8"
  - ㉒ PR. TOPSOIL FURNISH AND PLACE, 4"
  - ㉓ PR. SUBBASE GRANULAR MATERIAL, TYPE C
  - ㉔ PR. AGGREGATE SHOULDERS, TYPE B

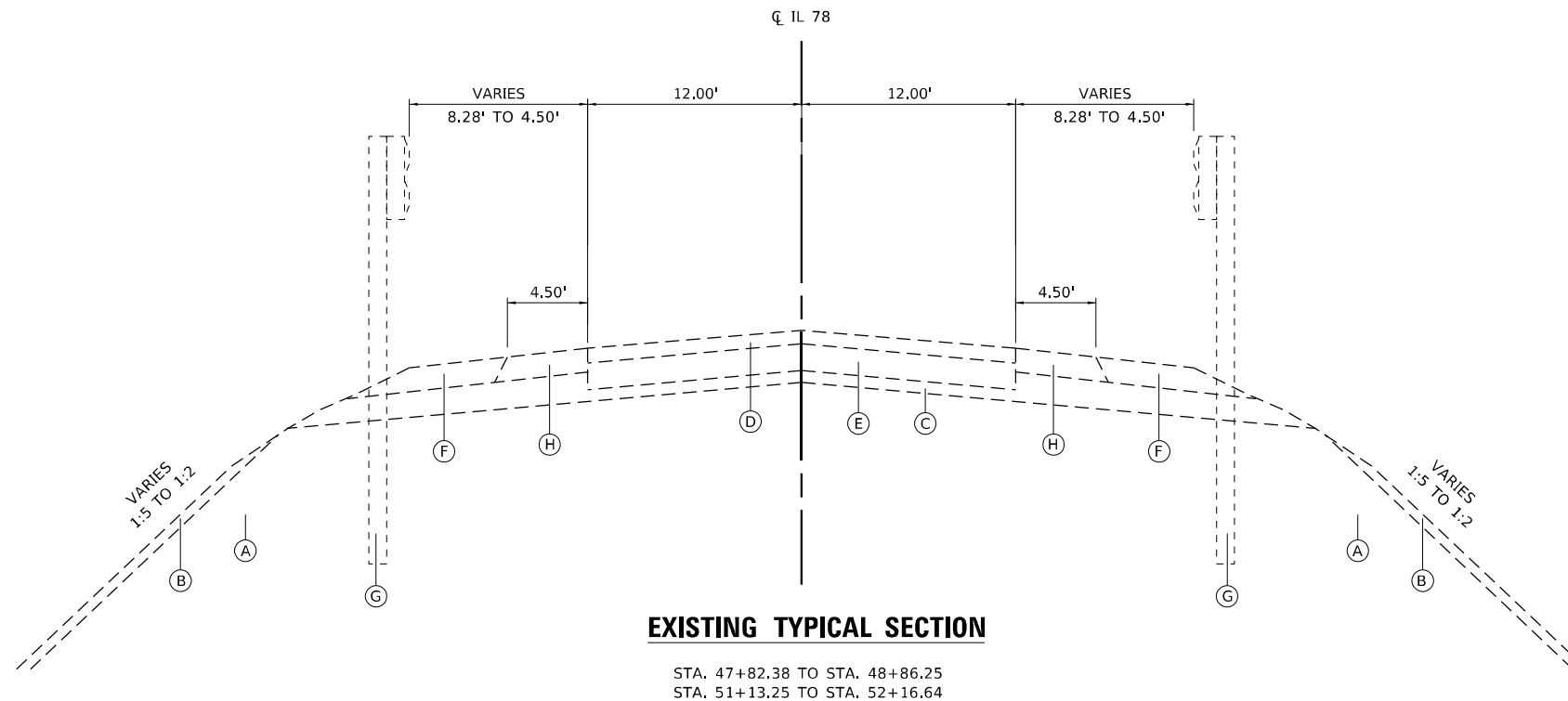
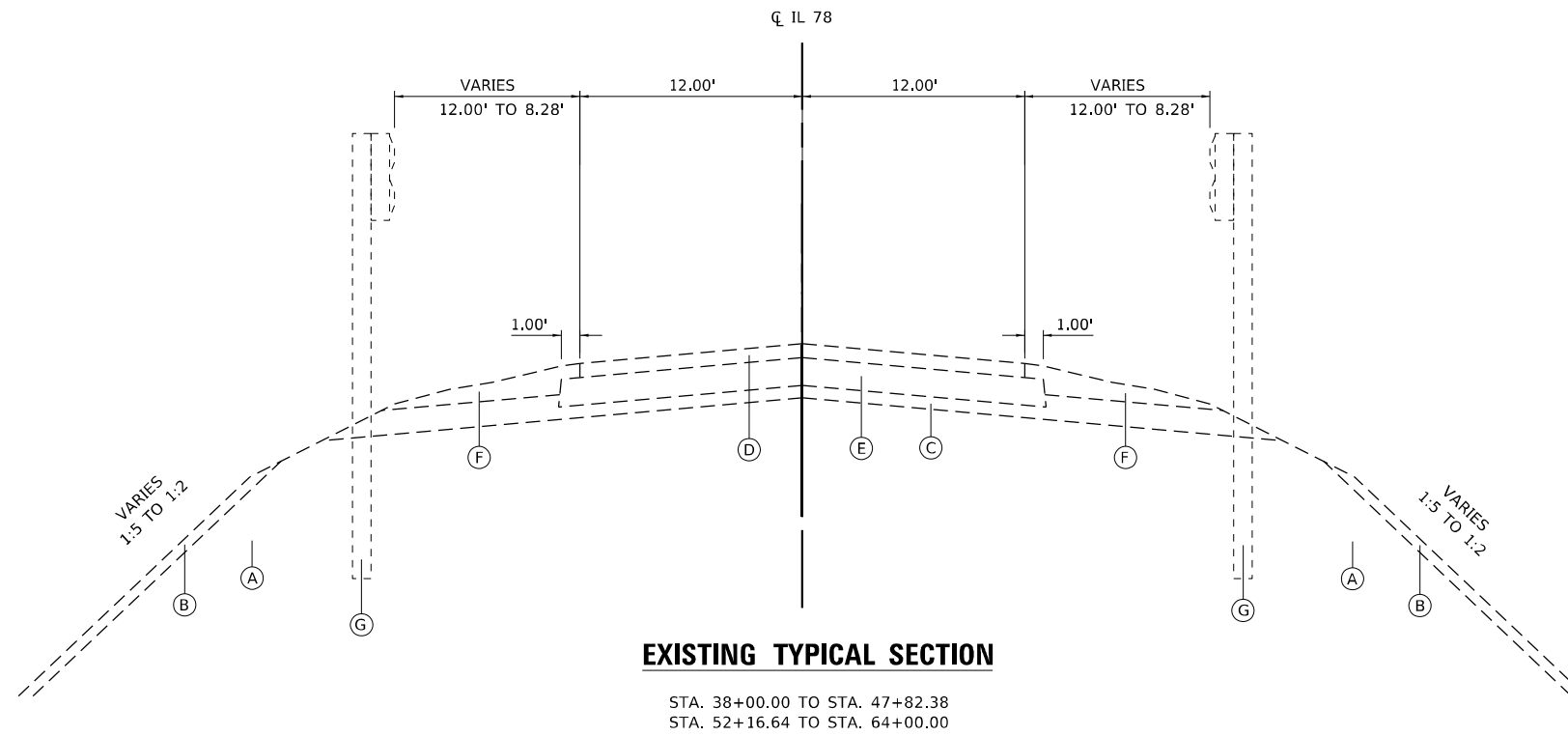

**SN 072-0032**

(EXISTING BACK-TO-BACK ABUTMENT SHELF)  
STA. 48+86.25 TO STA. 51+13.25  
(SEE NOTE)

NOTE: THIS STRUCTURE WAS CONSTRUCTED WITHOUT BRIDGE APPROACH SLABS AND CONNECTOR PAVEMENTS. THE EXISTING PAVEMENT WAS CONSTRUCTED TO THE ABUTMENT SHELF.

MODEL: D:\p4\h\... FILE NAME: P:\2021\112121\NC - IL 78 over FAI 74 & CH 184 CADD - DWG\4.7 FromCAD\_Sheets\184BDD18-shr-hydrical IL 78.dgn

**TWM**  
ENGINEERING  
GEOSPATIAL SERVICES

**TWM, INC.**  
www.twm-inc.com  
IL DESIGN FIRM  
LICENSE NO:  
184-001220

USER NAME = bbillhartz	DESIGNED -	REVISED -
PLOT SCALE = 20,0000 * / in.	DRAWN -	REVISED -
PLOT DATE = 10/4/2023	CHECKED -	REVISED -
	DATE -	REVISED -

**STATE OF ILLINOIS  
DEPARTMENT OF TRANSPORTATION**

<b>EXISTING TYPICAL SECTIONS IL 78</b>			
SCALE: N.T.S.	SHEET 1	OF 4 SHEETS	TO STA.

F.A.I. RTE.	SECTION	COUNTY	TOTAL SHEETS	SHEET NO.
74	[(72-30;48-29)HB-1]BRR	PEORIA & KNOX	115	11
CONTRACT NO. 68D48				
ILLINOIS FED. AID PROJECT				

**LEGEND**

LEGEND ITEMS IN LIGHT SHADED TEXT ARE FOR THE CH 18 STRUCTURE

- Ⓐ EX. EMBANKMENT
- Ⓑ EX. TOP SOIL, 4"
- Ⓒ EX. SUBBASE GRANULAR MATERIAL, 4" AND VARIES
- Ⓓ EX. HMA
- Ⓔ EX. BAM, 8"
- Ⓕ EX. AGGREGATE SHOULDERS
- Ⓖ EX. GUARDRAIL
- Ⓗ EX. HMA SHOULDERS, 8"
- Ⓘ EX. OIL & CHIP
- Ⓢ EX. AGGREGATE BASE COURSE
- ① PR. HMA SURFACE REMOVAL - BUTT JOINT
- ② PR. HMA SURFACE COURSE, IL-9.5, MIX "D", N50, 1.5"
- ③ PR. HMA SURFACE COURSE, IL-9.5, MIX "D", N50, 2"
- ④ PR. HMA BINDER COURSE, IL-9.5, N50, 1.75"
- ⑤ PR. HMA SURFACE REMOVAL (SPECIAL)
- ⑥ PR. BITUMINOUS SURFACE TREATMENT, A2
- ⑦ PR. BITUMINOUS MATERIALS (FOG SEAL)
- ⑧ PR. HMA SHOULDERS, 2"
- ⑨ PR. HMA SHOULDERS, 3.25"
- ⑩ PR. AGGREGATE WEDGE SHOULDER, TYPE B
- ⑪ PR. AGGREGATE SHOULDERS, TYPE B 8"
- ⑫ PR. PAVEMENT REMOVAL
- ⑬ PR. BASE COURSE WIDENING, 9"
- ⑭ PR. AGGREGATE BASE COURSE TYPE A, 11"
- ⑮ PR. STEEL PLATE BEAM GUARDRAIL, TYPE A, 6 FOOT POSTS
- ⑯ PR. GUARDRAIL AGGREGATE EROSION CONTROL
- ⑰ PR. CURB AND GUTTER (SPECIAL)
- ⑱ PR. MODIFIED URETHANE PAVEMENT MARKING - LINE 4"
- ⑲ PR. EMBANKMENT
- Ⓐ PR. PARALLEL WINGWALL (SEE BRIDGE PLANS)
- Ⓓ PR. HMA SHOULDERS, 8"
- Ⓔ PR. TOPSOIL FURNISH AND PLACE, 4"
- Ⓕ PR. SUBBASE GRANULAR MATERIAL, TYPE C
- Ⓖ PR. AGGREGATE SHOULDERS, TYPE B

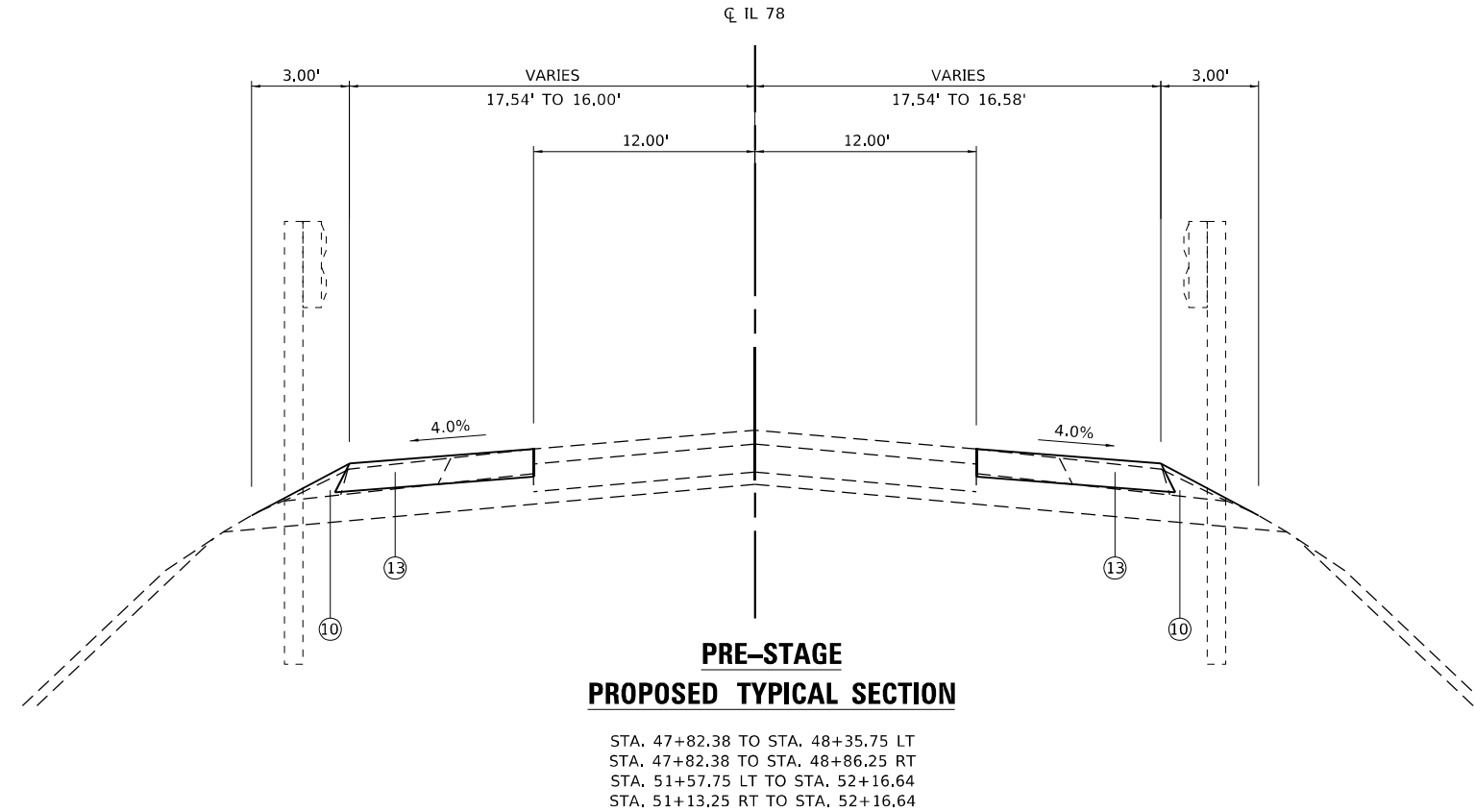
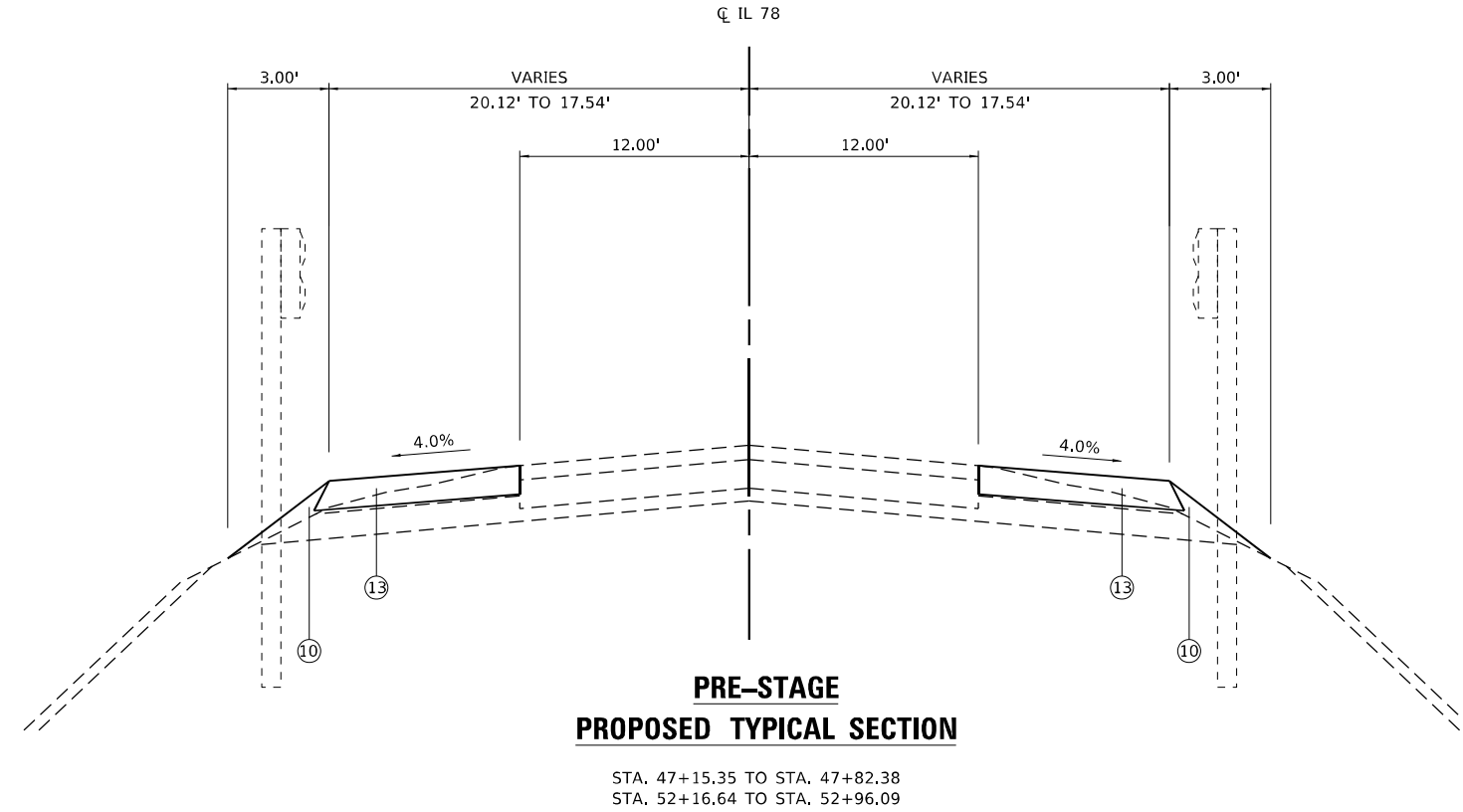

**SN 072-0032**

(EXISTING BACK-TO-BACK ABUTMENT SHELF)  
 STA. 48+86.25 TO STA. 51+13.25

STATE OF ILLINOIS  
 DEPARTMENT OF TRANSPORTATION

**PROPOSED TYPICAL SECTIONS (PRE-STAGE)**  
**IL 78**

SCALE: N.T.S. SHEET 2 OF 4 SHEETS STA. TO STA.

F.A.I. RTE.	SECTION	COUNTY	TOTAL SHEETS	SHEET NO.
74	[(72-30;48-29)HB-1]BRR	PEORIA & KNOX	115	12
				CONTRACT NO. 68D48
ILLINOIS FED. AID PROJECT				

MODEL PATH: H:\2023\1021127\102112710 - IL 78 over FAI 74 & CH 184 CADD - DWG\4.7 FromCAD\_Sheets\1021127102112710 - IL 78.dgn  
 FILE NAME: P:\2023\1021127\102112710 - IL 78 over FAI 74 & CH 184 CADD - DWG\4.7 FromCAD\_Sheets\1021127102112710 - IL 78.dgn

**TWM**  
 TWM, INC.  
 www.twm-inc.com  
 IL DESIGN FIRM  
 LICENSE NO: 184-001220

USER NAME = bbillhartz	DESIGNED -	REVISED -
	DRAWN -	REVISED -
PLOT SCALE = 20,0000' / in.	CHECKED -	REVISED -
PLOT DATE = 10/4/2023	DATE -	REVISED -

**LEGEND**

LEGEND ITEMS IN LIGHT SHADED TEXT ARE FOR THE CH 18 STRUCTURE

- (A) EX. EMBANKMENT
  - (B) EX. TOP SOIL, 4"
  - (C) EX. SUBBASE GRANULAR MATERIAL, 4" AND VARIES
  - (D) EX. HMA
  - (E) EX. BAM, 8"
  - (F) EX. AGGREGATE SHOULDERS
  - (G) EX. GUARDRAIL
  - (H) EX. HMA SHOULDERS, 8"
  - (I) EX. OIL & CHIP
  - (J) EX. AGGREGATE BASE COURSE
- 
- ① PR. HMA SURFACE REMOVAL - BUTT JOINT
  - ② PR. HMA SURFACE COURSE, IL-9.5, MIX "D", N50, 1.5"
  - ③ PR. HMA SURFACE COURSE, IL-9.5, MIX "D", N50, 2"
  - ④ PR. HMA BINDER COURSE, IL-9.5, N50, 1.75"
  - ⑤ PR. HMA SURFACE REMOVAL (SPECIAL)
  - ⑥ PR. BITUMINOUS SURFACE TREATMENT, A2
  - ⑦ PR. BITUMINOUS MATERIALS (FOG SEAL)
  - ⑧ PR. HMA SHOULDERS, 2"
  - ⑨ PR. HMA SHOULDERS, 3.25"
  - ⑩ PR. AGGREGATE WEDGE SHOULDER, TYPE B
  - ⑪ PR. AGGREGATE SHOULDERS, TYPE B 8"
  - ⑫ PR. PAVEMENT REMOVAL
  - ⑬ PR. BASE COURSE WIDENING, 9"
  - ⑭ PR. AGGREGATE BASE COURSE TYPE A, 11"
  - ⑮ PR. STEEL PLATE BEAM GUARDRAIL, TYPE A, 6 FOOT POSTS
  - ⑯ PR. GUARDRAIL AGGREGATE EROSION CONTROL
  - ⑰ PR. CURB AND GUTTER (SPECIAL)
  - ⑱ PR. MODIFIED URETHANE PAVEMENT MARKING - LINE 4"
  - ⑲ PR. EMBANKMENT
  - ⑳ PR. PARALLEL WINGWALL (SEE BRIDGE PLANS)
  - ㉑ PR. HMA SHOULDERS, 8"
  - ㉒ PR. TOPSOIL FURNISH AND PLACE, 4"
  - ㉓ PR. SUBBASE GRANULAR MATERIAL, TYPE C
  - ㉔ PR. AGGREGATE SHOULDERS, TYPE B

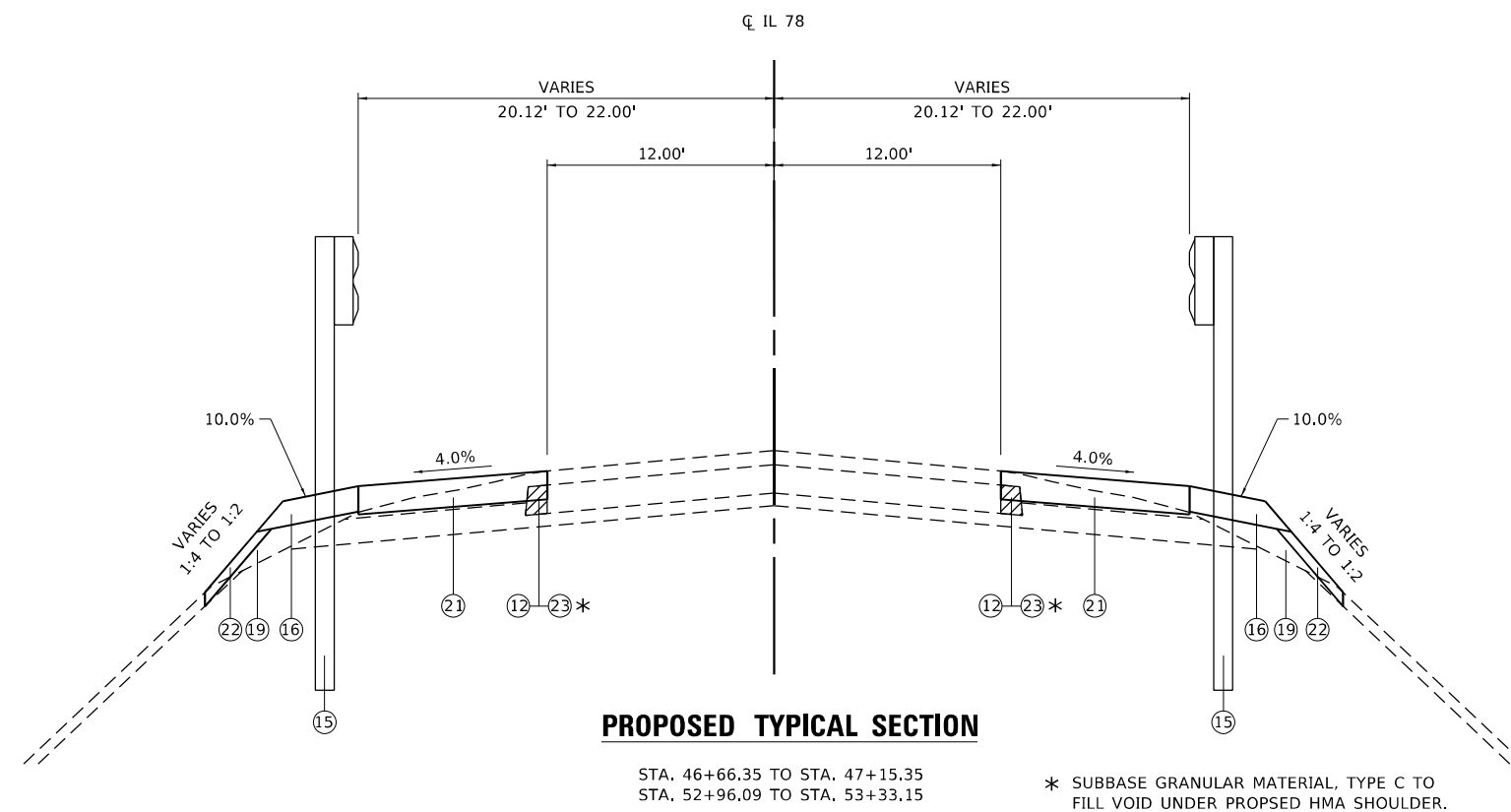
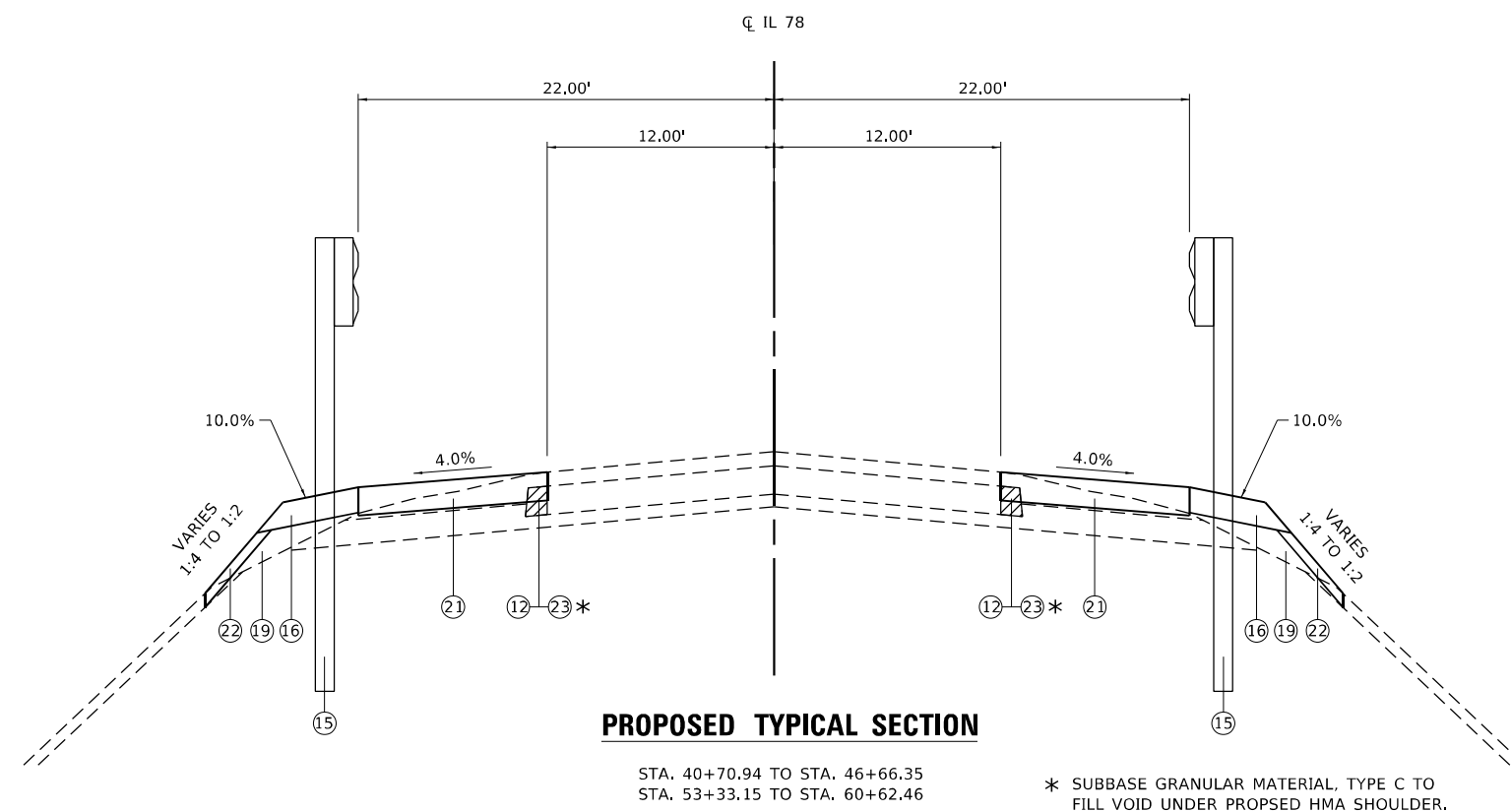

**SN 072-0032**

(INCLUDING CONNECTOR PAVEMENTS)  
STA. 48+35.75 TO STA. 51+57.75

MODEL: D:\p\h\... FILE NAME: P:\2021\121122\IL-IL 78 over FAI 74 & CH 184 CADD - DWG\4.7 FromCAD\_Sheets\184BDD18-sh-hydrical IL 78.dgn

**TWM**  
ENGINEERING  
GEOSPATIAL SERVICES

**TWM, INC.**  
www.twm-inc.com

IL DESIGN FIRM  
LICENSE NO:  
184-001220

USER NAME = bbillhartz	DESIGNED -	REVISED -
	DRAWN -	REVISED -
PLOT SCALE = 20,0000 * / in.	CHECKED -	REVISED -
PLOT DATE = 10/4/2023	DATE -	REVISED -

**STATE OF ILLINOIS  
DEPARTMENT OF TRANSPORTATION**

**PROPOSED TYPICAL SECTIONS  
IL 78**

SCALE: N.T.S. SHEET 3 OF 4 SHEETS STA. TO STA.

F.A.I. RTE.	SECTION	COUNTY	TOTAL SHEETS	SHEET NO.
74	[(72-30;48-29)HB-1]BRR	PEORIA & KNOX	115	13
CONTRACT NO. 68D48				
ILLINOIS FED. AID PROJECT				

**LEGEND**

LEGEND ITEMS IN LIGHT SHADED TEXT ARE FOR THE CH 18 STRUCTURE

- (A) EX. EMBANKMENT
- (B) EX. TOP SOIL, 4"
- (C) EX. SUBBASE GRANULAR MATERIAL, 4" AND VARIES
- (D) EX. HMA
- (E) EX. BAM, 8"
- (F) EX. AGGREGATE SHOULDERS
- (G) EX. GUARDRAIL
- (H) EX. HMA SHOULDERS, 8"
- (I) EX. OIL & CHIP
- (J) EX. AGGREGATE BASE COURSE
  
- ① PR. HMA SURFACE REMOVAL - BUTT JOINT
- ② PR. HMA SURFACE COURSE, IL-9.5, MIX "D", N50, 1.5"
- ③ PR. HMA SURFACE COURSE, IL-9.5, MIX "D", N50, 2"
- ④ PR. HMA BINDER COURSE, IL-9.5, N50, 1.75"
- ⑤ PR. HMA SURFACE REMOVAL (SPECIAL)
- ⑥ PR. BITUMINOUS SURFACE TREATMENT, A2
- ⑦ PR. BITUMINOUS MATERIALS (FOG SEAL)
- ⑧ PR. HMA SHOULDERS, 2"
- ⑨ PR. HMA SHOULDERS, 3.25"
- ⑩ PR. AGGREGATE WEDGE SHOULDER, TYPE B
- ⑪ PR. AGGREGATE SHOULDERS, TYPE B 8"
- ⑫ PR. PAVEMENT REMOVAL
- ⑬ PR. BASE COURSE WIDENING, 9"
- ⑭ PR. AGGREGATE BASE COURSE TYPE A, 11"
- ⑮ PR. STEEL PLATE BEAM GUARDRAIL, TYPE A, 6 FOOT POSTS
- ⑯ PR. GUARDRAIL AGGREGATE EROSION CONTROL
- ⑰ PR. CURB AND GUTTER (SPECIAL)
- ⑱ PR. MODIFIED URETHANE PAVEMENT MARKING - LINE 4"
- ⑲ PR. EMBANKMENT
- ⑳ PR. PARALLEL WINGWALL (SEE BRIDGE PLANS)
- ㉑ PR. HMA SHOULDERS, 8"
- ㉒ PR. TOPSOIL FURNISH AND PLACE, 4"
- ㉓ PR. SUBBASE GRANULAR MATERIAL, TYPE C
- ㉔ PR. AGGREGATE SHOULDERS, TYPE B

BASE COURSE WIDENING, 9"  
CONSTRUCTED IN THE PRE-STAGE

**SN 072-0032**

(INCLUDING CONNECTOR PAVEMENTS)  
STA. 48+35.75 TO STA. 51+57.75

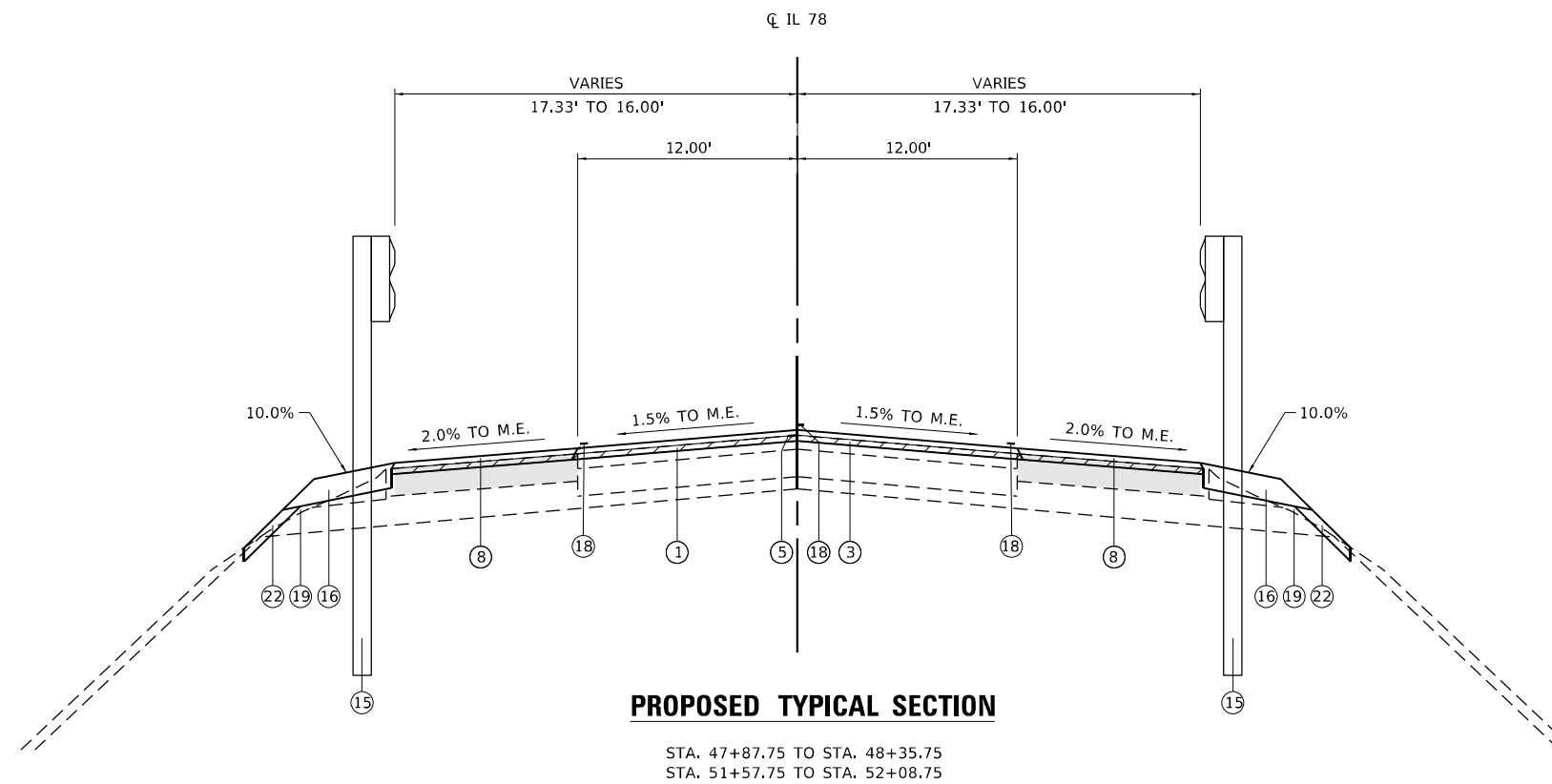
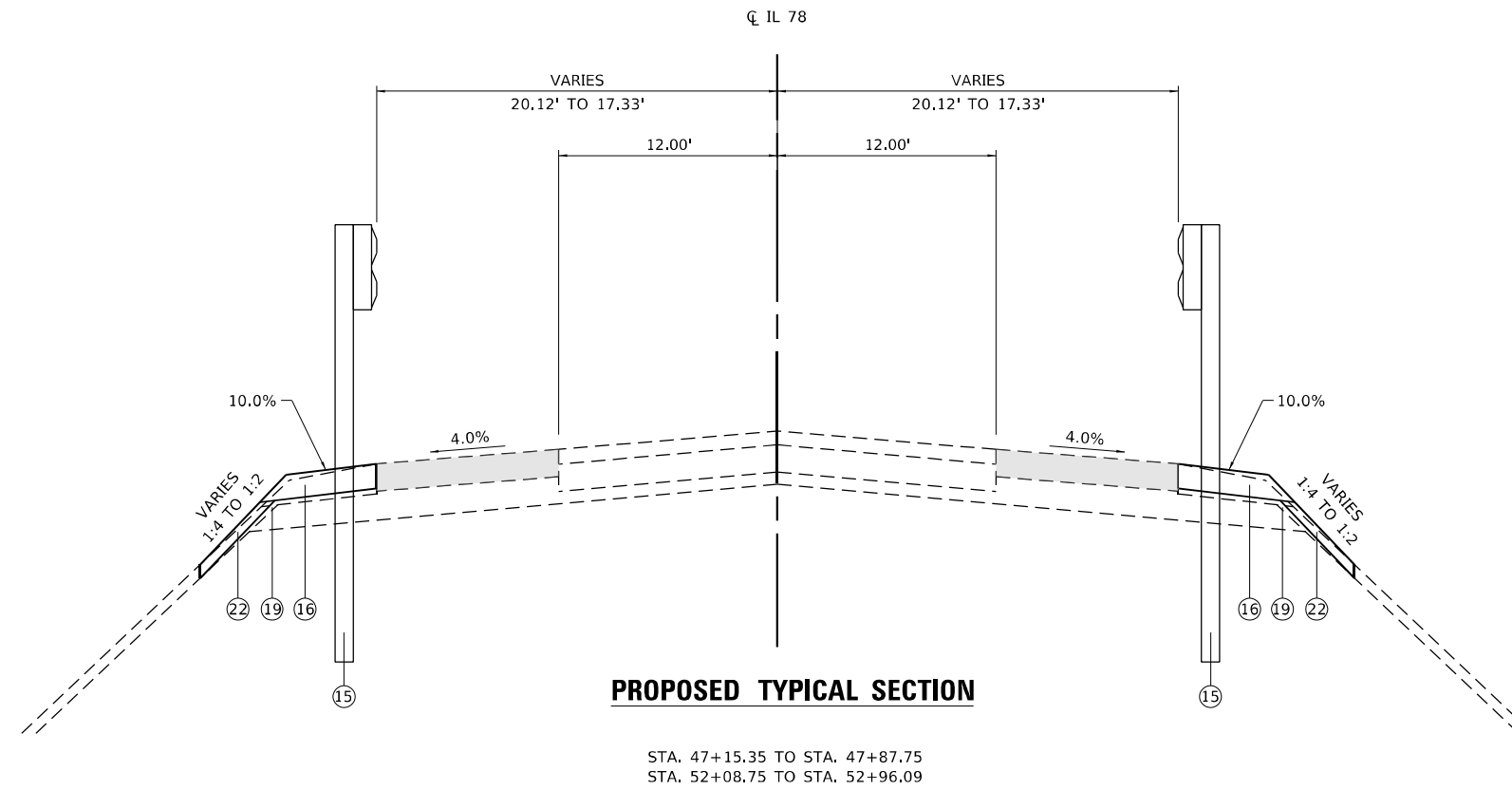

MODEL: D:\p\h\... FILE NAME: P:\2021\12\1122\NC - IL 78 over FA1 74 & CH 184 CADD - DWG\4.7\_Tran\CAD\_Sheet\1\468D48.dwg; h:\p\h\...; IL 78.dgn



**TWM, INC.**  
www.twm-inc.com  
IL DESIGN FIRM LICENSE NO: 184-001220

USER NAME = bbillhartz	DESIGNED -	REVISED -
	DRAWN -	REVISED -
PLOT SCALE = 20,0000 * / in.	CHECKED -	REVISED -
PLOT DATE = 10/4/2023	DATE -	REVISED -

**STATE OF ILLINOIS  
DEPARTMENT OF TRANSPORTATION**

**PROPOSED TYPICAL SECTIONS  
IL 78**

SCALE: N.T.S. SHEET 4 OF 4 SHEETS STA. TO STA.

F.A.I. RTE.	SECTION	COUNTY	TOTAL SHEETS	SHEET NO.
74	[(72-30;48-29)HB-1]BRR	PEORIA & KNOX	115	14
CONTRACT NO. 68D48				
ILLINOIS FED. AID PROJECT				

EARTHWORK SCHEDULE							
LOCATION		20200100	FOR INFORMATION ONLY			20400800	21101615
		EARTH EXCAVATION	EARTH EXCAVATION ADJUSTED FOR 25% SHRINKAGE	EMBANKMENT	BALANCE WASTE (+) SHORTAGE (-)	FURNISHED EXCAVATION	TOPSOIL FURNISH AND PLACE, 4"
STATION	TO	STATION	CU YD	CU YD	CU YD	CU YD	SQ YD
<b>SN 072-0032</b>							
STA. 42+00	TO	STA. 60+00	1019	764	935	-171	7603.8
SUB-TOTAL:			1019	764	935	-171	7603.8
PAY TOTAL:			1020				7604

FENCE SCHEDULE					
LOCATION				66500105	X6650202
				WOVEN WIRE FENCE, 4'	WOVEN WIRE FENCE REMOVAL
STATION	TO	STATION	LT/RT	FOOT	FOOT
<b>SN 072-0032</b>					
48+85.75	TO	48+87.07	LT	72.7	
48+85.75	TO	48+90.18	RT	52.1	
48+87.25	TO	48+87.07	LT		81.1
48+87.25	TO	48+90.18	RT		60.4
51+12.25	TO	51+17.21	LT		56.3
51+13.75	TO	51+17.21	LT	47.8	
51+10.62	TO	51+13.75	RT	48.5	
51+10.62	TO	51+12.25	RT		56.8
TOTAL:				221.1	254.0
PAY TOTAL:				221	254

EROSION SCHEDULE							
LOCATION		28000400	28000500	28200200	X2810128		
		PERIMETER EROSION BARRIER	INLET AND PIPE PROTECTION	FILTER FABRIC	STONE RIPRAP, CLASS B4 (SPECIAL)		
STATION	TO	STATION	LT/RT	FOOT	EACH	SQ YD	SQ YD
<b>SN 072-0032</b>							
41+73.75	TO	49+28.33	LT	911.5			
40+70.94	TO	49+28.33	RT	969.0			
48+35.75			LT			51.9	51.9
48+35.75			RT			52.7	52.7
48+51.72			LT		1		
48+57.91			LT		1		
50+71.67	TO	60+14.30	LT	1046.1			
50+71.67	TO	60+62.95	RT	1104.6			
51+42.75			LT			42.2	42.2
51+42.75			RT			48.3	48.3
TOTAL:				4031.2	2.0	195.1	195.1
PAY TOTAL:				4031	2	195	195

SHOULDER SCHEDULE									
LOCATION				31101900	35650400	48101200	48102100	48203005	48203029
				SUBBASE GRANULAR MATERIAL, TYPE C	BASE COURSE WIDENING, 9"	AGGREGATE SHOULDERS, TYPE B	AGGREGATE WEDGE SHOULDER, TYPE B	HOT-MIX ASPHALT SHOULDERS, 2"	HOT-MIX ASPHALT SHOULDERS, 8"
STATION	TO	STATION	LT/RT	TON	SQ YD	TON	TON	SQ YD	SQ YD
<b>SN 072-0032</b>									
40+70.94	TO	41+34.85	RT			12.9			
41+34.85	TO	47+15.35	RT	11.3					670.4
41+73.35	TO	42+34.85	LT			16.2			
42+34.85	TO	47+15.35	LT	9.3					550.1
47+15.35	TO	48+35.75	LT		78.0		7.0		
47+15.35	TO	48+86.25	RT		105.1		10.0		
47+87.75	TO	48+35.75	LT					23.8	
47+87.75	TO	48+35.75	RT					23.9	
51+57.75	TO	52+08.75	LT					24.6	
51+57.75	TO	52+08.75	RT					28.9	
51+57.75	TO	52+96.09	LT		91.7		8.1		
51+13.25	TO	52+96.09	RT		127.6		9.8		
52+01.99	TO	55+32.71	LT			10.8			
52+01.99	TO	56+29.81	RT			8.7			
52+96.09	TO	59+64.65	LT	13.0					809.1
52+96.09	TO	60+14.65	RT	14.0					817.9
TOTAL:				47.6	402.3	48.0	34.9	101.2	2847.5
PAY TOTAL:				48	402	48	35	101	2847

MOWING SCHEDULE			
LOCATION		25000750	MOWING
		ASSUMING 2 MOWINGS	
STATION	TO	STATION	ACRE
<b>SN 072-0032</b>			
41+73.75	TO	49+28.33	0.520
40+70.94	TO	49+28.33	0.590
50+71.67	TO	55+32.71	0.318
50+71.67	TO	56+29.81	0.384
TOTAL:			1.81
PAY TOTAL:			1.75

STATE OF ILLINOIS  
DEPARTMENT OF TRANSPORTATION

SCHEDULE OF QUANTITIES  
IL 78

F.A.I. RTE.	SECTION	COUNTY	TOTAL SHEETS	SHEET NO.
74	[(72-30;48-29)HB-1]BRR	PEORIA & KNOX	115	15
CONTRACT NO. 68D48				
ILLINOIS FED. AID PROJECT				

MODEL: D:\p\h\j  
FILE NAME: P:\2021\211221C - IL 78 over FAI 74 & Ch. 1B4 CADD - DWG\4.7 FromCAD\_Sheets\1468018.dwg:schedule-IL-78.dgn



USER NAME = bbillhartz  
DESIGNED -  
DRAWN -  
PLOT SCALE = 2,000' / in.  
CHECKED -  
PLOT DATE = 10/4/2023  
DATE -

REVISOR -  
REVISOR -  
REVISOR -  
REVISOR -

SCALE: SHEET 1 OF 4 SHEETS STA. TO STA.





SEEDING SCHEDULE										
LOCATION				25000210	25000400	25000500	25000600	25100630	25100635	28000250
				SEEDING CLASS 2A	NITROGEN FERTILIZER NUTRIENT	PHOSPHORUS FERTILIZER NUTRIENT	POTASSIUM FERTILIZER NUTRIENT	EROSION CONTROL BLANKET	HEAVY DUTY EROSION CONTROL BLANKET	TEMPORARY EROSION CONTROL SEEDING
STATION	TO	STATION	LT/RT	ACRE	POUND	POUND	POUND	SQ YD	SQ YD	POUND
SN 072-0032										
41+37.75	TO	44+50.00	LT					722.9		
41+37.75	TO	49+28.33	LT	0.408	36.7	36.7	36.7			81.60
40+70.94	TO	43+50.00	RT					143.5		
40+70.94	TO	49+28.33	RT	0.211	19.0	19.0	19.0			42.20
43+50.00	TO	49+28.33	RT						937.0	
44+50.00	TO	49+28.33	LT						1339.1	
50+71.67	TO	55+32.71	LT	0.657	59.1	59.1	59.1			131.40
50+71.67	TO	56+29.81	RT	0.295	26.6	26.6	26.6			59.00
50+71.67	TO	59+00.00	LT						3256.4	
50+71.67	TO	59+00.00	RT						1293.7	
59+00.00	TO	60+14.30	LT					135.3		
59+00.00	TO	60+62.46	RT					216.5		
TOTAL:				1.6	141.4	141.4	141.4	1218.1	6826.1	314.2
PAY TOTAL:				1.50	140	140	140	1218	6826	314

MISCELLANEOUS SCHEDULE	
60100060	
LOCATION	CONCRETE HEADWALLS FOR PIPE DRAINS
STATION	EACH
SN 072-0032	
NE QUADRANT	1.0
NW QUADRANT	1.0
SE QUADRANT	1.0
SW QUADRANT	1.0
TOTAL:	4.0
PAY TOTAL:	4

SEE STRUCTURE PLANS FOR ADDITIONAL DETAILS

STAGING SCHEDULE S.N. 072-0032												
LOCATION			40600990	70106500	70106700	70107005	70300150	70400100	70400125	70400200	70600260	70600332
			TEMPORARY RAMP	TEMPORARY BRIDGE TRAFFIC SIGNALS	TEMPORARY RUMBLE STRIPS	PAVEMENT MARKING BLACKOUT TAPE, 5"	SHORT TERM PAVEMENT MARKING REMOVAL *	TEMPORARY CONCRETE BARRIER	PINNING TEMPORARY CONCRETE BARRIER	RELOCATE TEMPORARY CONCRETE BARRIER	IMPACT ATTENUATORS, TEMPORARY (FULLY REDIRECTIVE, NARROW), TEST LEVEL 3	IMPACT ATTENUATORS, RELOCATE (FULLY REDIRECTIVE, NARROW), TEST LEVEL 3
STATION	TO	STATION	SQ YD	EACH	EACH	FOOT	SQ FT	FOOT	EACH	FOOT	EACH	EACH
STAGE I												
NORTH END				1	3	1565.4	652.2					
SOUTH END					3							
47+03.99												
47+09.05	TO	52+91.01						582.0	99.0		1	
48+29.08	TO	48+35.75	11.9									
52+96.10												
STAGE II												
47+03.99						221.88	92.5					1
47+09.05	TO	51+92.01	11.9							582.0		
52+96.10												
POST STAGE												
47+87.75	TO	47+94.42	23.7									
48+29.08	TO	48+35.75	23.7									
51+57.75	TO	51+64.42	23.7									
52+02.08	TO	52+08.75	23.7									
TOTAL:			118.6	1.0	6.0	1787.3	744.7	582.0	99.0	582.0	2.0	2.0
PAY TOTAL:			119	1	6	1787	745	582	99	582	2	2

\* SEE PAVEMENT MARKING SCHEDULE FOR ADDITIONAL QUANTITIES

MODEL: D:\p4\h... FILE NAME: P:\02011212\1C - IL 78 over FA 74 & CH 1B4 CADD - DWG\4.7 Tran\CAD\_Sheets\1468D48.dwg:schedule-11\_78.dgn



**TWM, INC.**  
www.twm-inc.com  
IL DESIGN FIRM LICENSE NO: 184-001220  
USER NAME = bbillhartz  
PLOT SCALE = 2,000' / in.  
PLOT DATE = 10/4/2023

DESIGNED -  
DRAWN -  
CHECKED -  
DATE -  
REVISED -  
REVISED -  
REVISED -  
REVISED -

STATE OF ILLINOIS  
DEPARTMENT OF TRANSPORTATION

**SCHEDULE OF QUANTITIES**  
**IL 78**  
SCALE: SHEET 3 OF 4 SHEETS STA. TO STA.

F.A.I. RTE.	SECTION	COUNTY	TOTAL SHEETS	SHEET NO.
74	[(72-30;48-29)HB-1]BRR	PEORIA & KNOX	115	17
CONTRACT NO. 68D48				
ILLINOIS FED. AID PROJECT				

**PAVEMENT MARKING SCHEDULE**

LOCATION					70300100		70300150		70300221		78009004		78300202	
					SHORT TERM PAVEMENT MARKING		SHORT TERM PAVEMENT MARKING REMOVAL *		TEMPORARY PAVEMENT MARKING - LINE 4" - PAINT		MODIFIED URETHANE PAVEMENT MARKING - LINE 4"		PAVEMENT MARKING REMOVAL - WATER BLASTING	
STATION	TO	STATION	LOCATION	TYPE	AFTER TEMPORARY CONCRETE BARRIER REMOVAL	HMA ROADWAY TAPERS	AFTER TEMPORARY CONCRETE BARRIER REMOVAL	HMA ROADWAY TAPERS	AFTER TEMPORARY CONCRETE BARRIER REMOVAL	HMA ROADWAY TAPERS	FINAL PAVEMENT MARKINGS	AFTER TEMPORARY CONCRETE BARRIER REMOVAL	HMA ROADWAY TAPERS	
					FOOT	FOOT	SQ FT	SQ FT	YELLOW	WHITE	YELLOW	WHITE	SQ FT	SQ FT
<b>SN 072-0032</b>														
41+34.85	TO	47+87.75	SHOULDER DIAGONALS, RT		13.1		4.4							
41+34.85	TO	47+87.75	EDGE LINE, RT	SINGLE						652.9		652.9		217.6
42+34.85	TO	47+87.75	EDGE LINE, LT	SINGLE						552.9		552.9		184.3
42+34.85	TO	47+87.75	SHOULDER DIAGONALS, LT		11.1		3.7							
47+87.35	TO	48+35.75	EDGE LINE, LT	SINGLE						96.0				16.00
47+87.75	TO	48+35.75	EDGE LINE, RT	SINGLE						96.0				16.00
47+87.75	TO	48+35.75	CENTERLINE	SINGLE		9.6		1.6		192.0				32.00
47+87.75	TO	52+08.75	CENTERLINE	DOUBLE							842.0			
47+87.75	TO	52+08.75	EDGE LINE, LT	SINGLE								421.0		
47+87.75	TO	52+08.75	EDGE LINE, RT	SINGLE								421.0		
47+87.75	TO	48+35.75	CENTERLINE	SINGLE										
48+35.75	TO	51+57.75	EDGE LINE, LT	SINGLE					322.0					107.3
48+35.75	TO	51+57.75	EDGE LINE, RT	SINGLE					322.0					107.3
48+35.75	TO	51+57.75	CENTERLINE	DOUBLE	32.2		10.7		644.0					214.7
51+57.75	TO	52+08.75	EDGE LINE, LT	SINGLE						102.0				17.0
51+57.75	TO	52+08.75	EDGE LINE, RT	SINGLE						102.0				17.0
51+57.75	TO	52+08.75	CENTERLINE	DOUBLE		10.2		1.7		204.0				34.0
52+08.75	TO	59+64.65	SHOULDER DIAGONALS, LT		15.1		5.0							
52+08.75	TO	60+14.65	SHOULDER DIAGONALS, RT		16.1		5.4							
52+08.75	TO	59+64.65	EDGE LINE, LT	SINGLE						755.9		755.9		251.97
52+08.75	TO	60+14.65	EDGE LINE, RT	SINGLE						805.9		805.9		268.63
SUBTOTAL					87.6	19.8	29.2	3.3	1288.0	3559.6	842.0	3609.6	429.3	1054.5
TOTAL:					107.4		32.0		4847.6		4451.6		1483.9	
PAY TOTAL:					107		32		4848		4452		1484	

\* SEE STAGING SCHEDULE S.N. 072-0032 FOR ADDITIONAL QUANTITIES

**TREE REMOVAL SCHEDULE**

LOCATION					20100110
LOCATION					TREE REMOVAL (6 TO 15 UNITS DIAMETER)
STATION	TO	STATION	LT/RT	UNIT	
<b>SN 072-0032</b>					
48+23.75	TO	48+47.75	LT	26	
TOTAL:				26	
PAY TOTAL:				26	

**BARRIER WALL REFLECTOR SCHEDULE**

LOCATION				78200011
LOCATION				BARRIER WALL REFLECTORS, TYPE C
STATION	TO	STATION	LT/RT	EACH
<b>SN 072-0032</b>				
48+71.75	TO	51+27.75	LT	4.0
48+71.75	TO	51+27.75	RT	4.0
TOTAL:				8.0
PAY TOTAL:				8

\* SEE STAGING SCHEDULE FOR ADDITIONAL QUANTITIES



USER NAME = bbillhartz  
 DESIGNED -  
 DRAWN -  
 CHECKED -  
 DATE -  
 PLOT SCALE = 2,000' / in.  
 PLOT DATE = 10/4/2023

REVISIED -  
 REVISED -  
 REVISED -  
 REVISED -

**STATE OF ILLINOIS  
 DEPARTMENT OF TRANSPORTATION**

**SCHEDULE OF QUANTITIES  
 IL 78**

SCALE: SHEET 4 OF 4 SHEETS STA. TO STA.

F.A.I. RTE.	SECTION	COUNTY	TOTAL SHEETS	SHEET NO.
74	[(72-30;48-29)HB-1]BRR	PEORIA & KNOX	115	18
CONTRACT NO. 68D48				
ILLINOIS FED. AID PROJECT				



MODEL Path: I:\184\_CADD - DWG\4.7\_TranCAD\_Sheets\184-80-removal-IL-78\_pur-section.dgn  
FILE NAME: PurSection.dwg

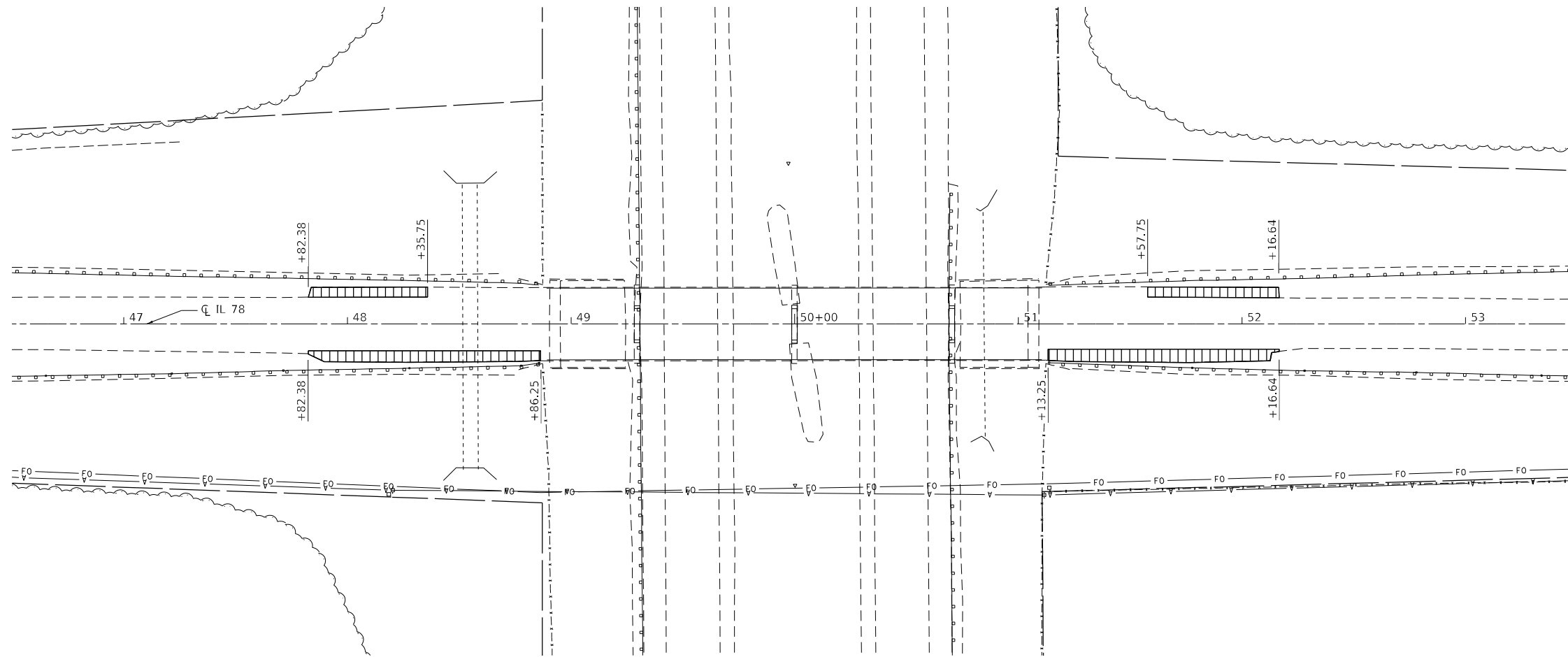

**LEGEND**

SCALE IN FEET



**TWM, INC.**  
www.twm-inc.com  
IL DESIGN FIRM  
LICENSE NO: 184-001220

USER NAME = bbillhartz	DESIGNED -	REVISED -
PLOT SCALE = 60,0000' / in.	DRAWN -	REVISED -
PLOT DATE = 10/4/2023	CHECKED -	REVISED -
	DATE -	REVISED -

**STATE OF ILLINOIS  
DEPARTMENT OF TRANSPORTATION**

<b>PRE-STAGE REMOVAL</b>			
<b>IL 78</b>			
SCALE: 1"=30'	SHEET 1	OF 2 SHEETS	STA. TO STA.

F.A.I. RTE.	SECTION	COUNTY	TOTAL SHEETS	SHEET NO.
74	[(72-30;48-29)HB-1]BRR	PEORIA & KNOX	115	20
CONTRACT NO. 68D48				
ILLINOIS FED. AID PROJECT				

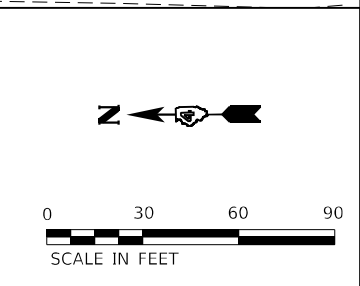
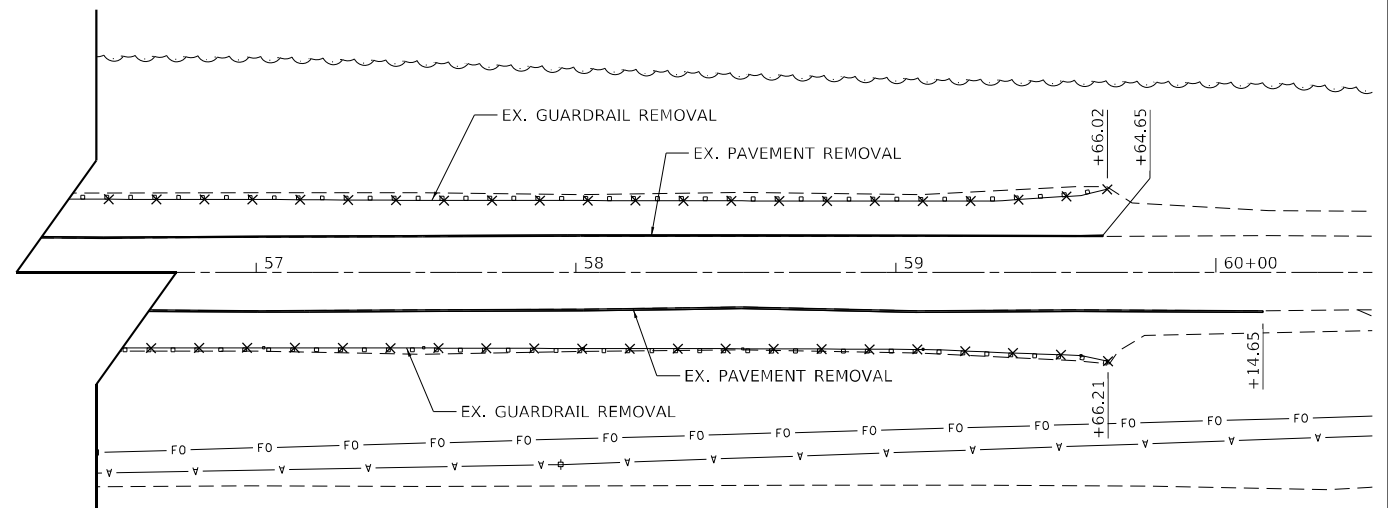
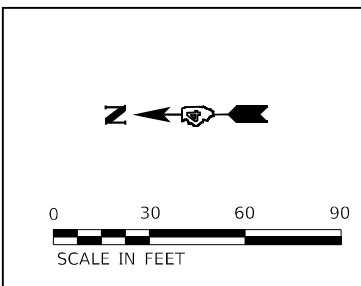
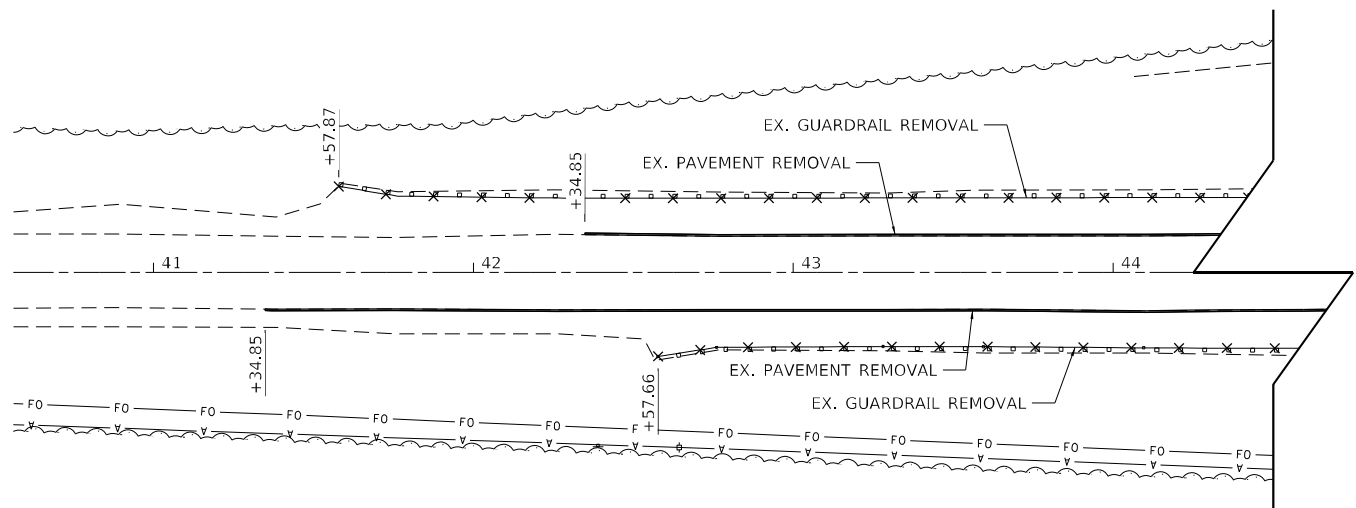
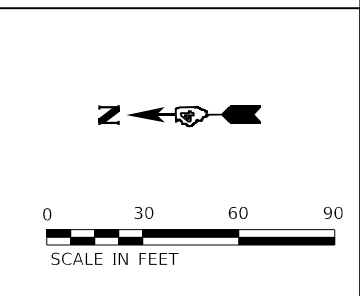
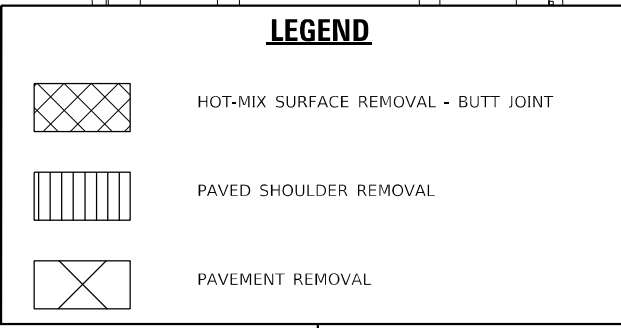
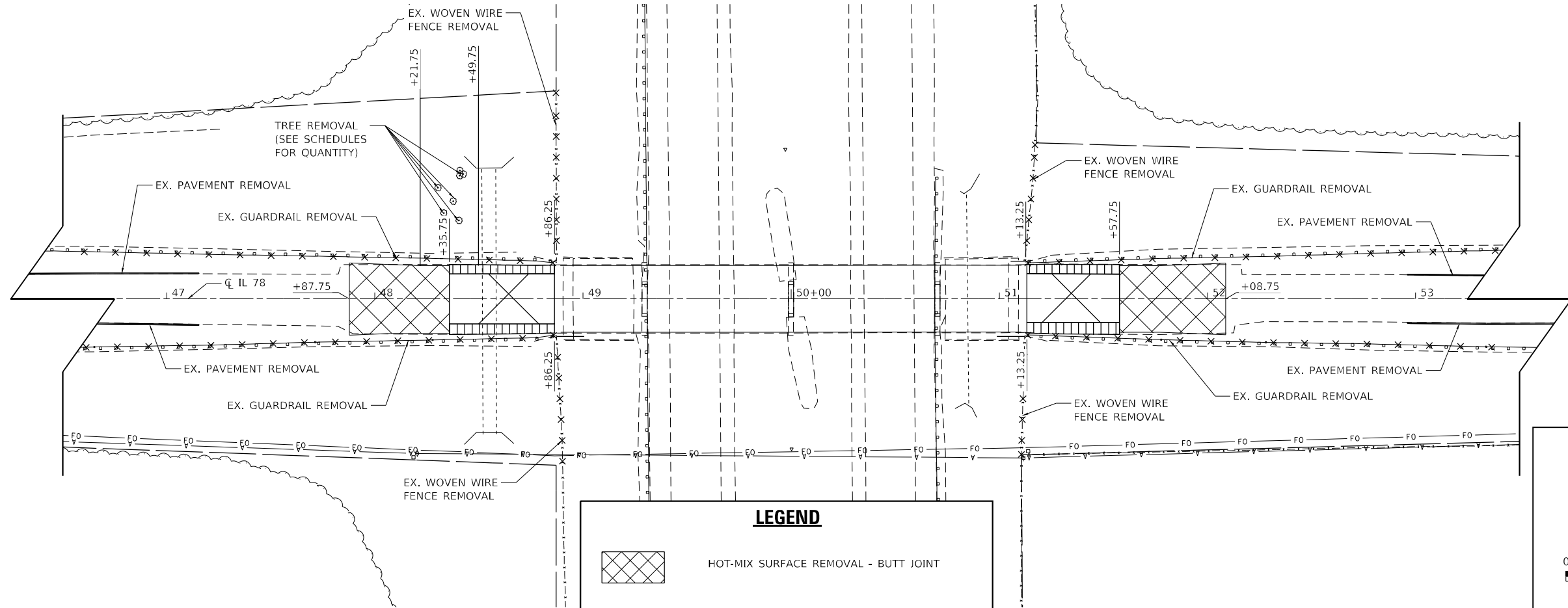

MODEL: D:\p\h\...  
 FILE NAME: P:\2021\1122\IL - IL 78 over FA 74 & CH 1B4 CADD - DWG\47\_TrimCAD\_Sheets\1468D48-shr-removal-11\_78.dgn



**TWM, INC.**  
 www.twm-inc.com  
 IL DESIGN FIRM LICENSE NO: 184-001220  
 USER NAME = bbillhartz  
 PLOT SCALE = 60,0000 \* / in.  
 PLOT DATE = 10/4/2023

DESIGNED -	REVISED -
DRAWN -	REVISED -
CHECKED -	REVISED -
DATE -	REVISED -

**STATE OF ILLINOIS**  
**DEPARTMENT OF TRANSPORTATION**

**REMOVAL**  
**IL 78**  
 SCALE: 1"=30'    SHEET 2    OF 2    SHEETS    STA.    TO STA.

F.A.I. RTE.	SECTION	COUNTY	TOTAL SHEETS	SHEET NO.
74	[(72-30;48-29)HB-1]BRR	PEORIA & KNOX	115	21
CONTRACT NO. 68D48				
ILLINOIS FED. AID PROJECT				

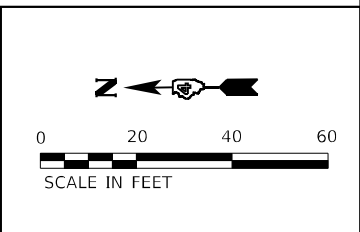
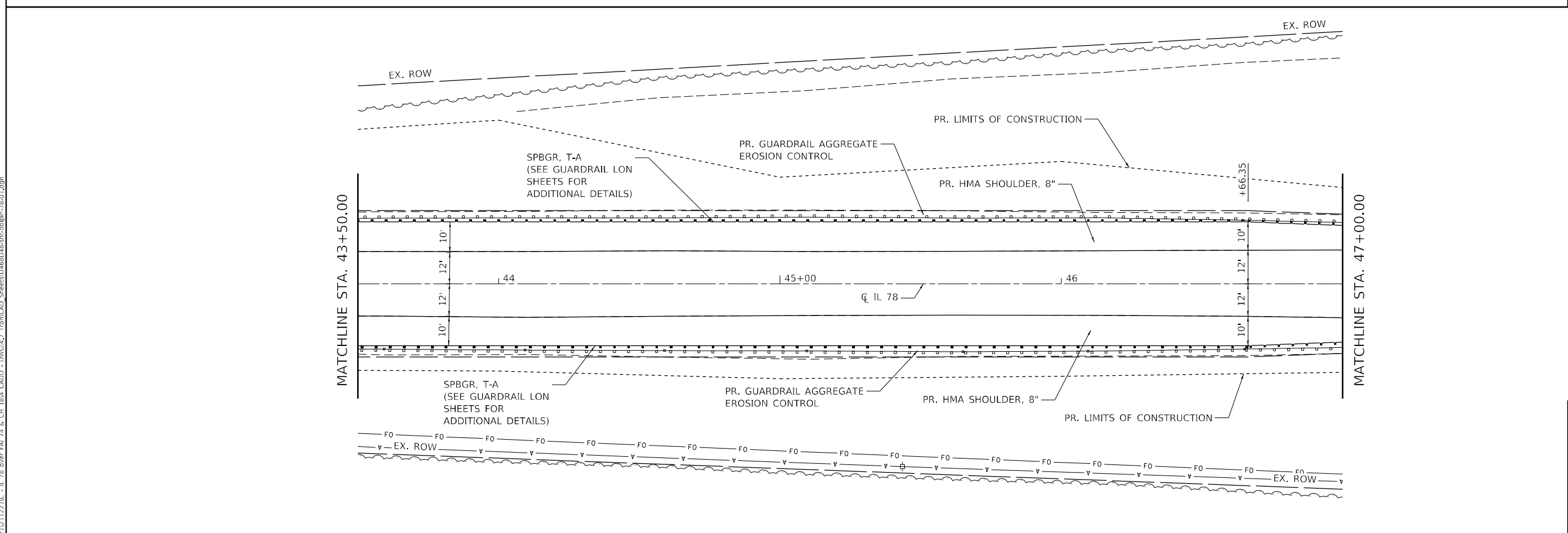
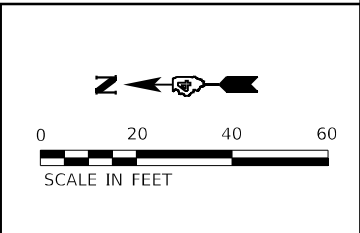
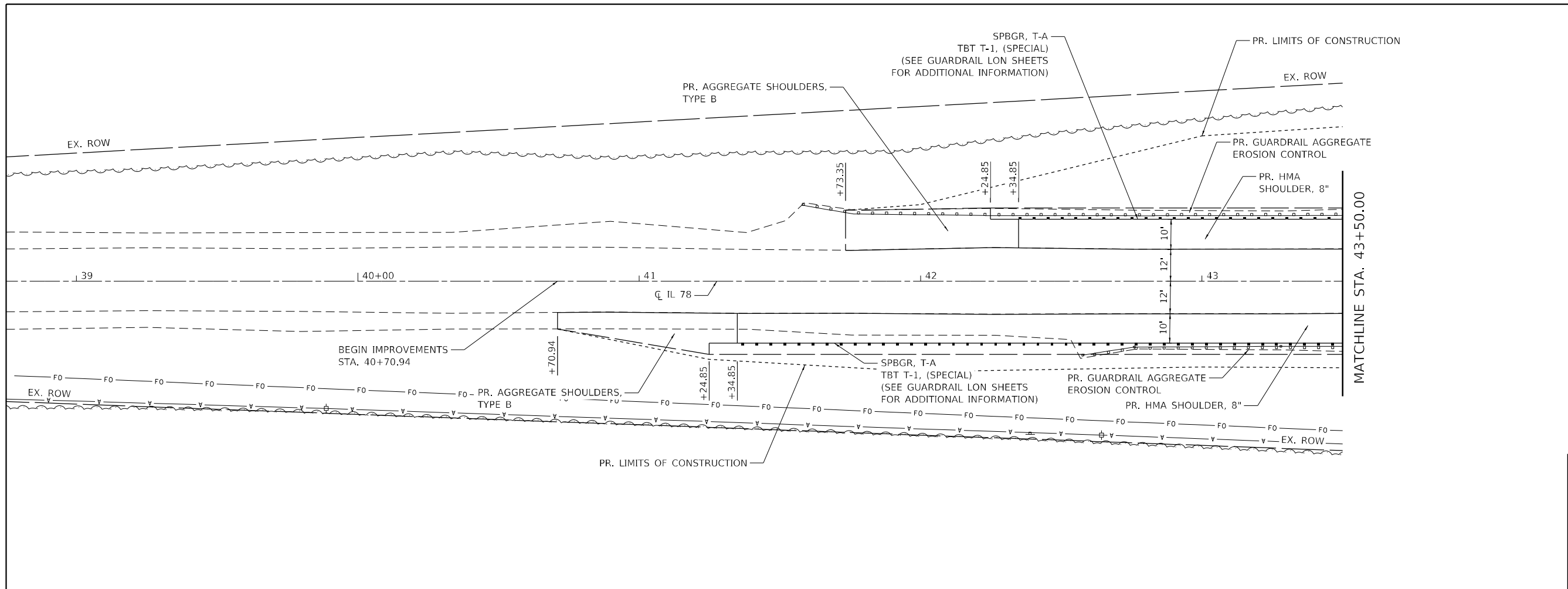

MODEL Path: I:\...  
 FILE NAME: P:\2021\1122\NC - IL 78 over FA 74 & Ch 1B4 CADD - DWG\4.7 Tran\CAD\_Sheet1(D468D48.dwg)-tblp-78.01.dwg

**TWM, INC.**  
 WWW.TWM-INC.COM  
 IL DESIGN FIRM  
 LICENSE NO: 184-001220

USER NAME = bbillhartz	DESIGNED -	REVISED -
PLOT SCALE = 40,0000 * / in.	DRAWN -	REVISED -
PLOT DATE = 10/4/2023	CHECKED -	REVISED -
	DATE -	REVISED -

**STATE OF ILLINOIS**  
**DEPARTMENT OF TRANSPORTATION**

**PLAN IL 78**  
 SCALE: 1"=20'  
 SHEET 1 OF 3 SHEETS  
 STA. 40+00.00 TO STA. 47+00.00

F.A.I. RTE.	SECTION	COUNTY	TOTAL SHEETS	SHEET NO.
74	[(72-30;48-29)HB-1]BRR	PEORIA & KNOX	115	22
CONTRACT NO. 68D48				
ILLINOIS FED. AID PROJECT				

PLAN	SURVEYED	DATE
	PLOTTED	
	ALIGNED	
	CHECKED	
	NO. _____	
	CADD FILE NAME	

PROFILE	SURVEYED	DATE
	PLOTTED	
	GRADES	
	CHECKED	
	NO. _____	
	STRUCTURE	
	NOTATIONS	
	CHWID	

MODEL: Defnair  
 FILE NAME: P:\2021\112121\IC - IL 78 over FAI 74 & Ch 18d CADD - DWG\47 TranC48 Sheets\68D48.dwg

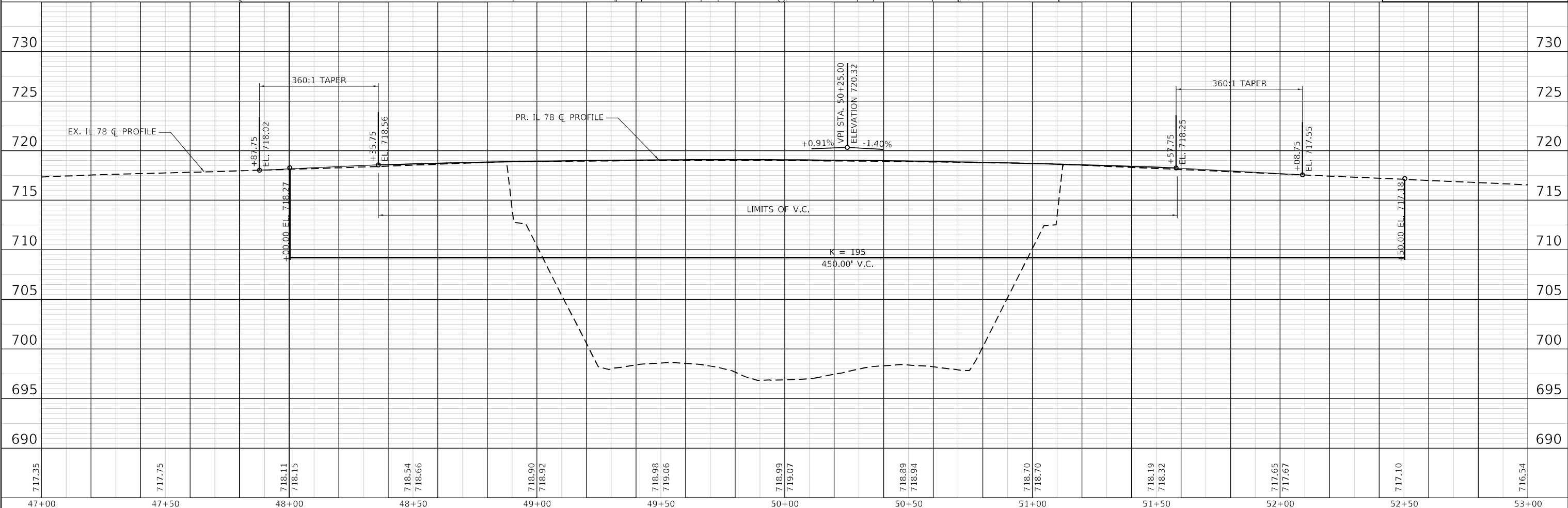
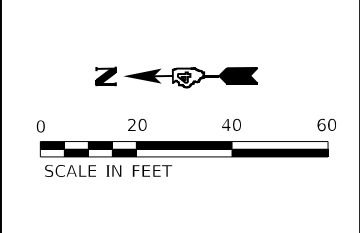
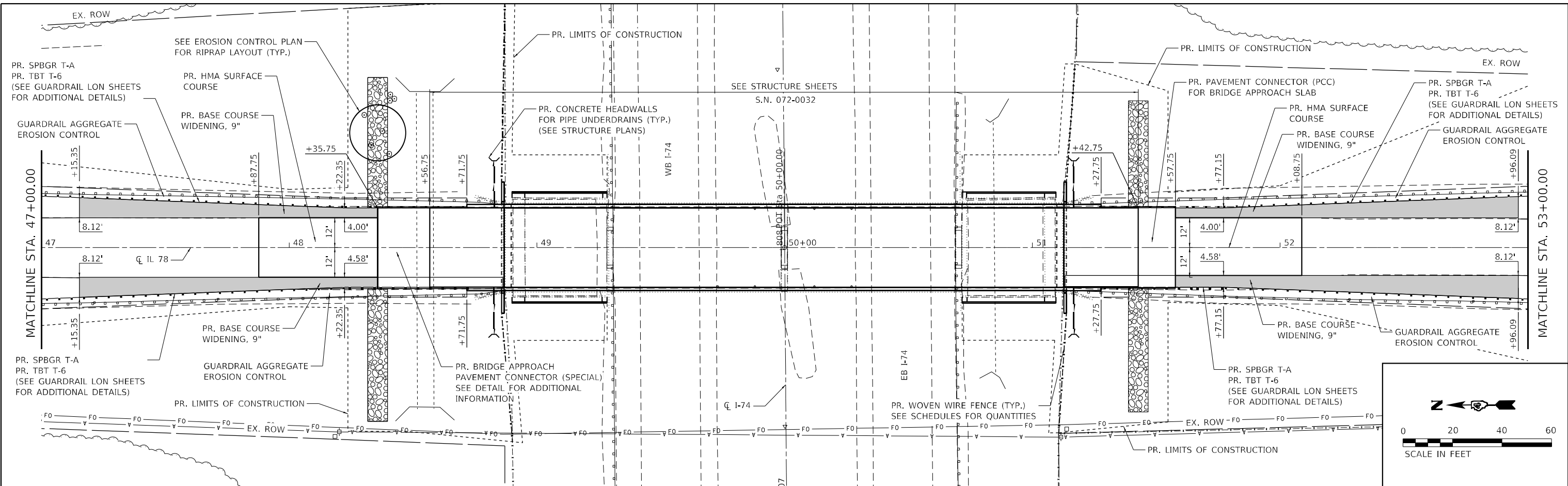

717.35	717.75	718.11 718.15	718.54 718.66	718.90 718.92	718.98 719.06	718.99 719.07	718.89 718.94	718.70 718.70	718.19 718.32	717.65 717.67	717.10	716.54
47+00	47+50	48+00	48+50	49+00	49+50	50+00	50+50	51+00	51+50	52+00	52+50	53+00

**TWM**  
 ENGINEERING  
 GEOSPATIAL SERVICES

**TWM, INC.**  
 www.twm-inc.com  
 IL DESIGN FIRM  
 LICENSE NO:  
 184-001220

USER NAME =	bbillhartz
PLOT SCALE =	40,0000' / in.
PLOT DATE =	10/01/2023

DESIGNED -	REVISD -
DRAWN -	REVISD -
CHECKED -	REVISD -
DATE -	REVISD -

**STATE OF ILLINOIS  
 DEPARTMENT OF TRANSPORTATION**

**PLAN AND PROFILE  
 IL 78**

SCALE: 1"=20'    SHEET 2 OF 3 SHEETS    STA. 47+00.00 TO STA. 53+00.00

F.A.I. RTE.	SECTION	COUNTY	TOTAL SHEETS	SHEET NO.
74	[(72-30;48-29)HB-1]BRR	PEORIA & KNOX	115	23
CONTRACT NO. 68D48				
ILLINOIS FED. AID PROJECT				

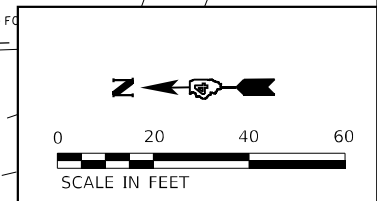
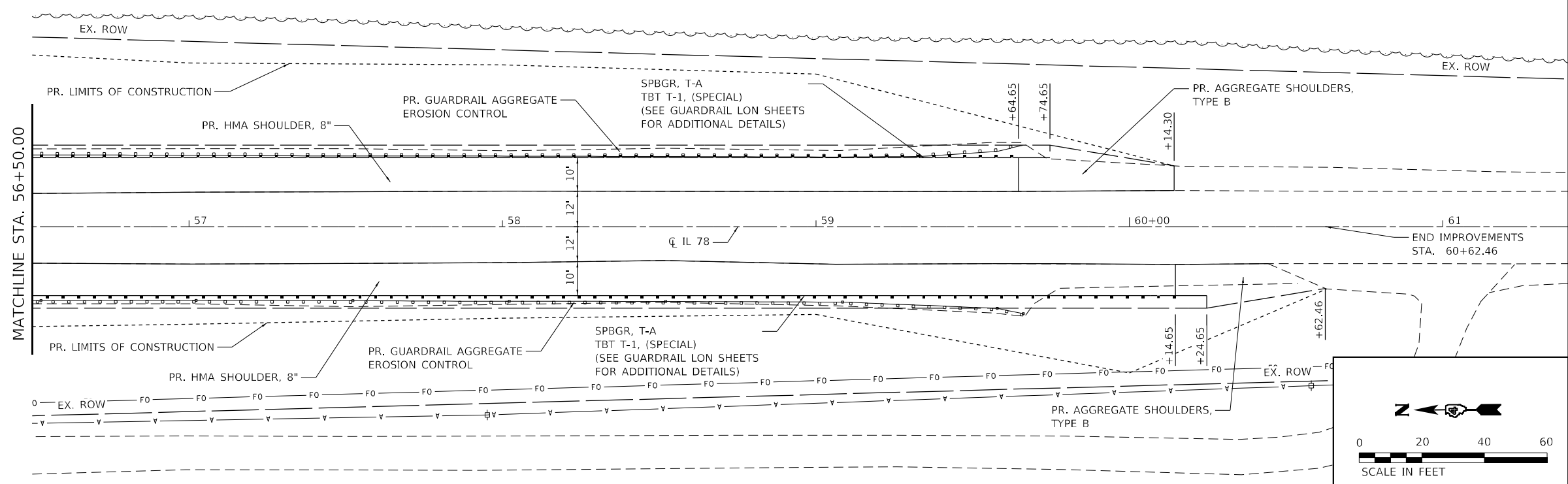
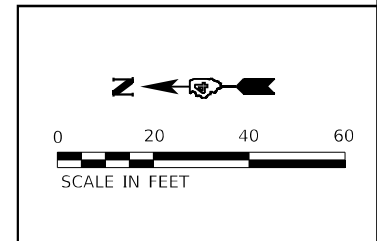
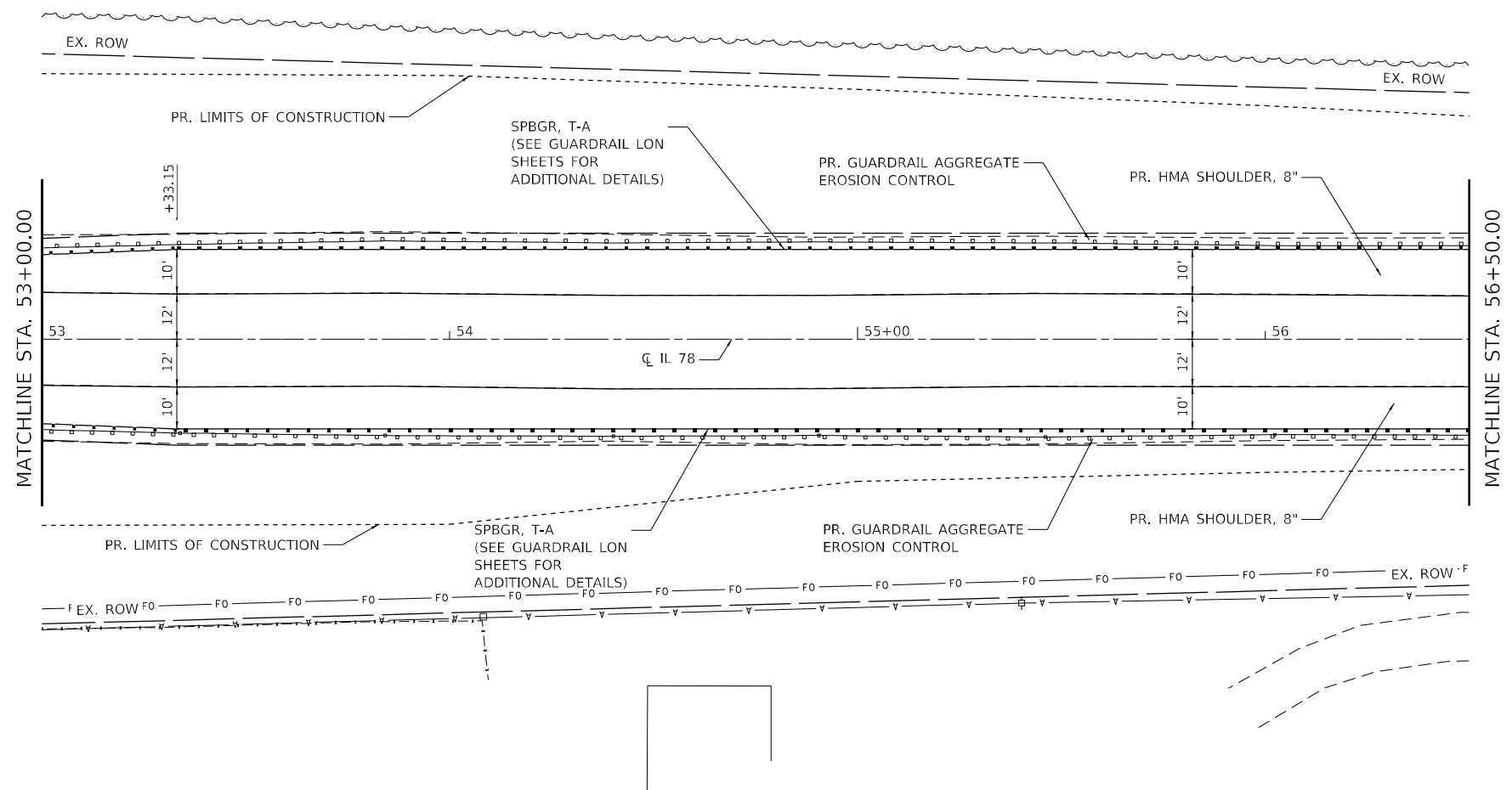

MODEL: D:\p4\h  
FILE NAME: P:\2021\112121\IC - IL 78 over FAI 74 & Ch. 1B4 CADD - DWG\4.7 FromCAD\_Sheet1(D468D48.dwg)-tblp-28-03.dwg

**TWM**  
**ENGINEERING**  
**GEOSPATIAL SERVICES**  
TWM, INC.  
www.twm-inc.com  
IL DESIGN FIRM  
LICENSE NO:  
53789-00220

USER NAME =	bhbilhartz
PLOT SCALE =	40,0000 * / in.
PLOT DATE =	10/4/2023

DESIGNED -	
DRAWN -	
CHECKED -	
DATE -	
REVISED -	
REVISED -	
REVISED -	
REVISED -	

**STATE OF ILLINOIS**  
**DEPARTMENT OF TRANSPORTATION**

**PLAN**  
**IL 78**  
SCALE: 1"=20'  
SHEET 3 OF 3 SHEETS  
STA. 53+00.00 TO STA. 61+00.00

F.A.I. RTE.	SECTION	COUNTY	TOTAL SHEETS	SHEET NO.
74	[(72-30;48-29)HB-1]BRR	PEORIA & KNOX	115	24
CONTRACT NO. 68D48				
ILLINOIS FED. AID PROJECT				



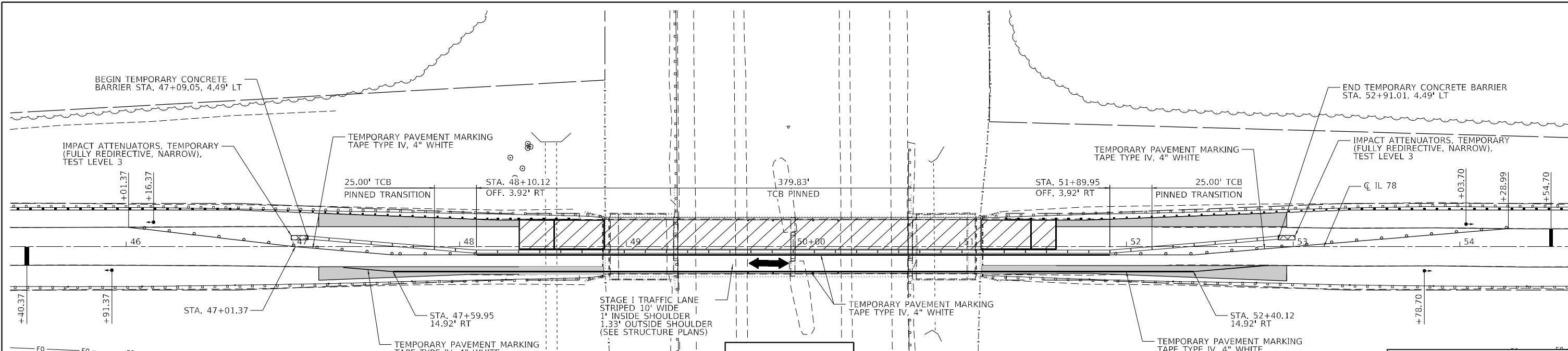

**STAGE I**

**LEGEND**

- WORK AREA
- IMPACT ATTENUATORS
- BASE COURSE WIDENING, 9"
- TRAFFIC SIGNAL
- TEMPORARY CONCRETE BARRIER
- TEMPORARY STOP BAR, 24"
- BASE COURSE WIDENING, 9" TBR

**NOTES:**

1. ALL OFFSET AND DIMENSIONS FOR THE TRAFFIC CONTROL BARRIER ARE TO THE TRAFFIC FACE OF THE TRAFFIC CONTROL BARRIER.
2. A MINIMUM OF 2 SIGNAL HEADS ARE REQUIRED PER APPROACH.
3. USE BLACKOUT TAPE APPROVED BY THE ENGINEER TO COVER ANY CONFLICTING RAISED REFLECTIVE PAVEMENT MARKERS. USE A MATERIAL APPROVED BY THE ENGINEER TO COVER THE LENSES PRIOR TO THE PLACEMENT OF THE BLACKOUT TAPE IN ORDER TO PROTECT THE LENSES FROM THE BLACKOUT TAPE ADHESIVE. ALL COSTS ASSOCIATED WITH PROVIDING, INSTALLING, AND REMOVING THE EXTRA MATERIAL TO COVER THE LENSES SHALL BE INCLUDED IN THE CONTRACT UNIT PRICE PER FOOT FOR PAVEMENT MARKING BLACKOUT TAPE OF THE SPECIFIED SIZE.
4. TRAFFIC CONTROL SHALL BE IN ACCORDANCE WITH STANDARD 701321 EXCEPT WHERE MODIFIED ON THIS PLAN SHEET.
5. THE ENGINEER OF TRAFFIC SHALL APPROVE ALL TIMING PARAMETERS.
6. THE TEMPORARY TRAFFIC SIGNAL HEADS SHALL BE PLACED AT THE LOCATIONS INDICATED ON THE PLAN SHEETS OR DIRECTED BY THE ENGINEER.

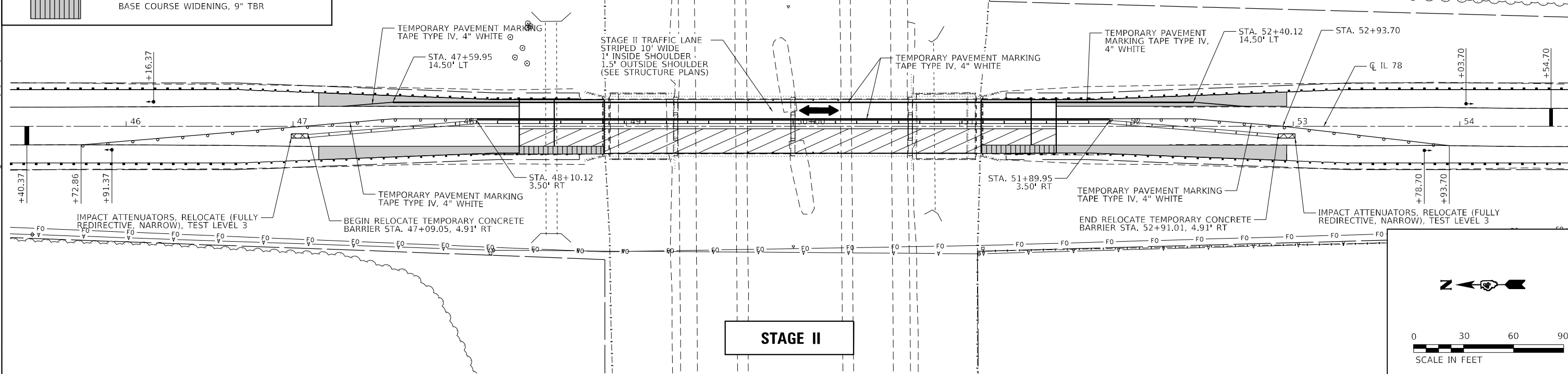
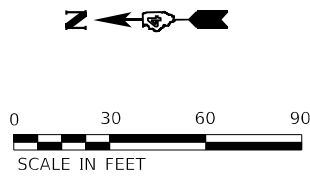

**STAGE II**

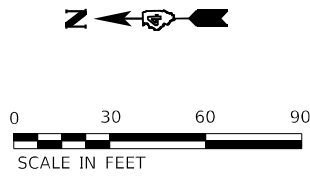

MODEL: D:\p1\112121\112121.dwg; FILE NAME: P112121.dwg; USER: bblillhartz; DATE: 10/4/2023

**TWM**  
ENGINEERING  
GEOSPATIAL SERVICES

**TWM, INC.**  
www.twm-inc.com  
IL DESIGN FIRM  
LICENSE NO: 184-001220

USER NAME = bblillhartz	DESIGNED -	REVISED -
PLOT SCALE = 60,0000 * / in.	DRAWN -	REVISED -
PLOT DATE = 10/4/2023	CHECKED -	REVISED -
	DATE -	REVISED -

**STATE OF ILLINOIS  
DEPARTMENT OF TRANSPORTATION**

**STAGING PLAN  
IL 78**

SCALE: 1"=30' SHEET 1 OF 1 SHEETS STA. TO STA.

F.A.I. RTE.	SECTION	COUNTY	TOTAL SHEETS	SHEET NO.
74	[(72-30;48-29)HB-1]BRR	PEORIA & KNOX	115	25
CONTRACT NO. 68D48				
ILLINOIS FED. AID PROJECT				

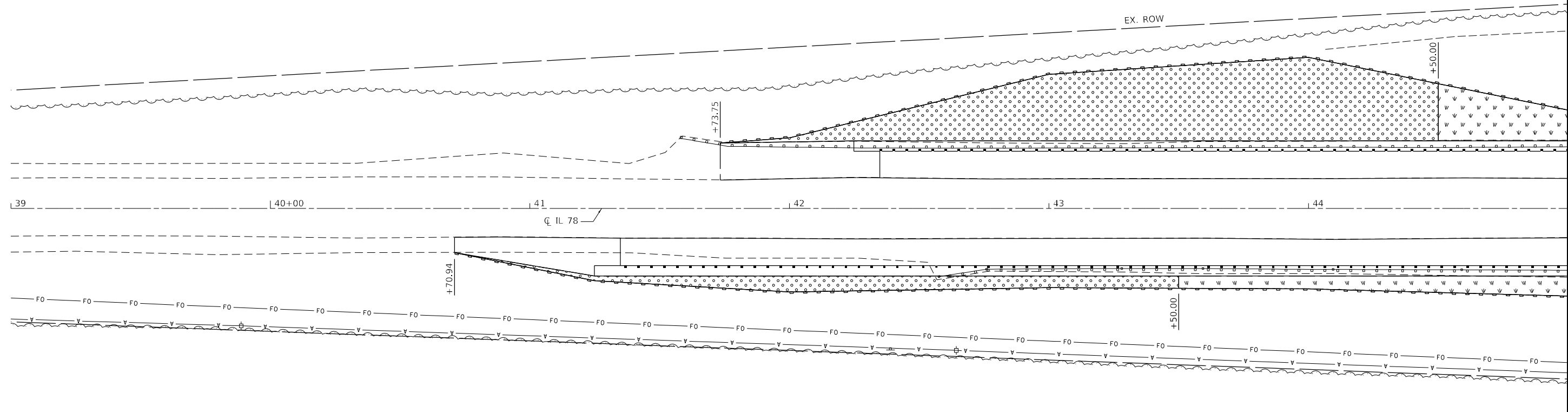



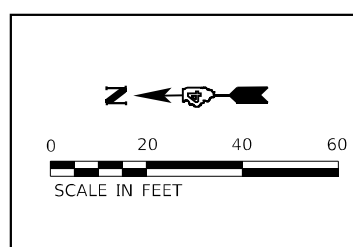

**NOTES:**

1. PLACE EROSION CONTROL BLANKET ON SLOPES FLATTER THAN 1:3
2. PLACE HEAVY DUTY EROSION CONTROL BLANKET ON SLOPES BETWEEN 1:3 AND 1:2



**LEGEND**

-  PR. SEEDING CLASS, 2A  
W/ FERTILIZER NUTRIENTS  
AND HEAVY-DUTY EROSION CONTROL BLANKET
-  PR. SEEDING CLASS, 2A  
W/ FERTILIZER NUTRIENTS  
AND EROSION CONTROL BLANKET
-  PR. INLET AND PIPE PROTECTION
-  PR. PERIMETER EROSION BARRIER
-  PR. STONE RIPRAP, CLASS B4 (SPECIAL)

MODEL: D:\6848\11221122\11221122\11221122.dwg - CH 184 CADD - DWG4.7 From CAD\_Sheet11(D488D488.dwg)-eros-IL 78.dwg



**TWM, INC.**  
WWW.TWM-INC.COM  
ILLINOIS DESIGN FIRM  
LICENSE NO: 184-001220

USER NAME = bbillhartz	DESIGNED -	REVISED -	
	DRAWN -	REVISED -	
PLOT SCALE = 40,0000 * / in.	CHECKED -	REVISED -	
PLOT DATE = 10/4/2023	DATE -	REVISED -	

<b>STATE OF ILLINOIS DEPARTMENT OF TRANSPORTATION</b>		<b>EROSION CONTROL PLAN IL 78</b>			F.A.I. RTE. 74	SECTION [(72-30;48-29)HB-1]BRR	COUNTY PEORIA & KNOX	TOTAL SHEETS 115	SHEET NO. 26
SCALE: 1"=20'		SHEET 1 OF 4 SHEETS		STA. 39+00.00 TO STA. 45+00.00		CONTRACT NO. 68D48 ILLINOIS FED. AID PROJECT			

**NOTES:**

1. PLACE EROSION CONTROL BLANKET ON SLOPES FLATTER THAN 1:3
2. PLACE HEAVY DUTY EROSION CONTROL BLANKET ON SLOPES BETWEEN 1:3 AND 1:2

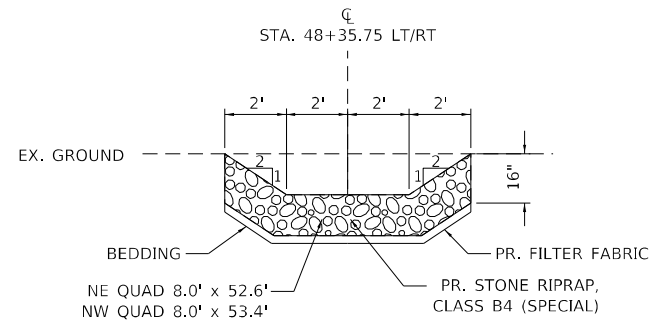
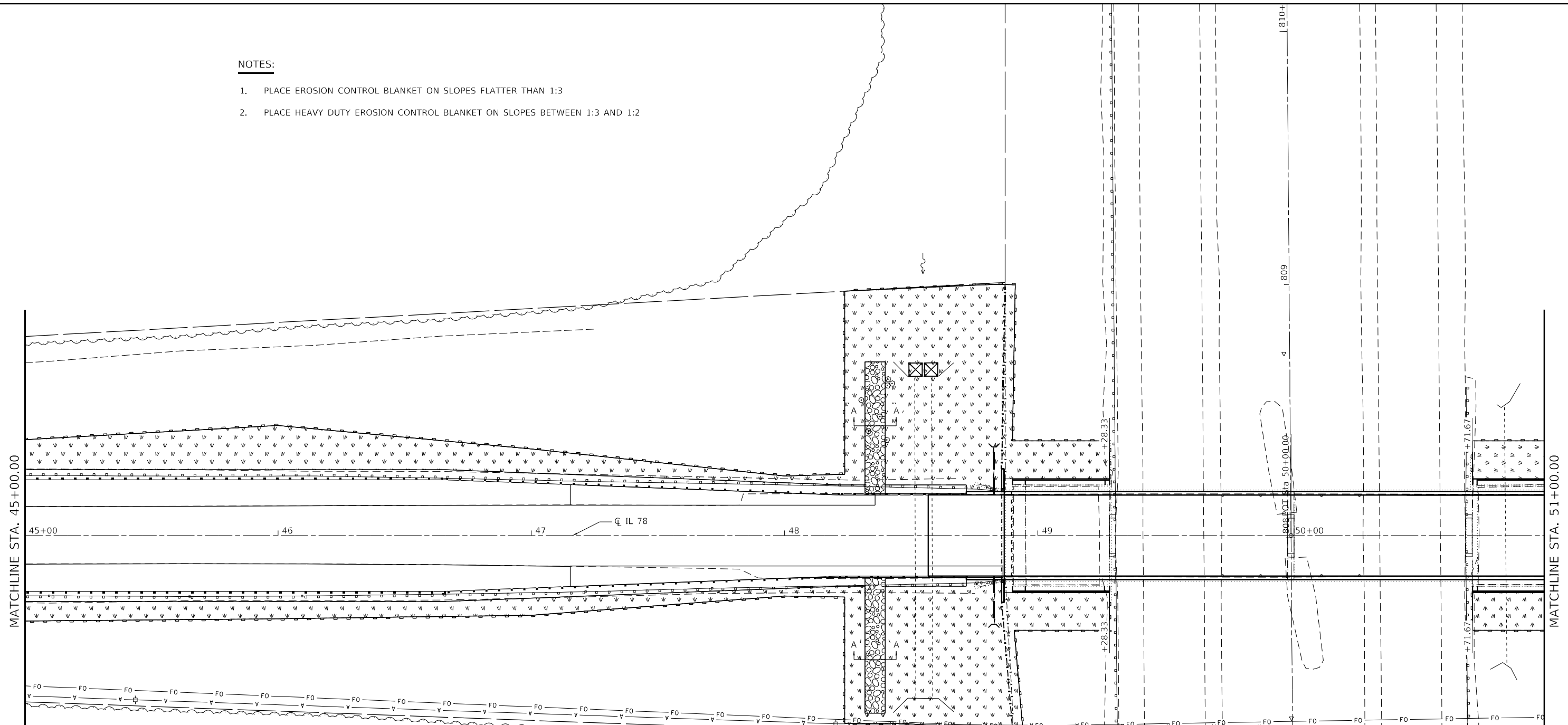

**SECTION A-A**  
**STONE RIPRAP, CLASS B4 (SPECIAL) DETAIL**  
**IL 78**

**LEGEND**

- PR. SEEDING CLASS, 2A W/ FERTILIZER NUTRIENTS AND HEAVY-DUTY EROSION CONTROL BLANKET
- PR. SEEDING CLASS, 2A W/ FERTILIZER NUTRIENTS AND EROSION CONTROL BLANKET
- PR. INLET AND PIPE PROTECTION
- PR. PERIMETER EROSION BARRIER
- PR. STONE RIPRAP, CLASS B4 (SPECIAL)

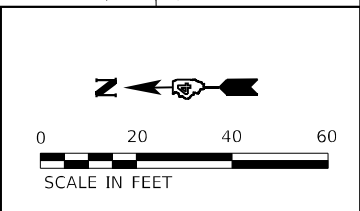

MODEL: D:\p\h\h\...  
 FILE NAME: P:\2023\11212121\IL\_78\_0ver FAI 74 & CH 1B4 CADD - DWG\47\_Tran\CAD\_Sheet\184-001220.dwg

**TWM, INC.**  
 ENGINEERING  
 GEOSPATIAL SERVICES

USER NAME = bbillhartz  
 PLOT SCALE = 40,0000 \* / in.  
 PLOT DATE = 10/4/2023

DESIGNED -  
 DRAWN -  
 CHECKED -  
 DATE -

REVISED -  
 REVISED -  
 REVISED -  
 REVISED -

**STATE OF ILLINOIS**  
**DEPARTMENT OF TRANSPORTATION**

**EROSION CONTROL PLAN**  
**IL 78**  
 SCALE: 1"=20' SHEET 2 OF 4 SHEETS STA. 45+00.00 TO STA. 51+00.00

F.A.I. RTE.	SECTION	COUNTY	TOTAL SHEETS	SHEET NO.
74	[(72-30;48-29)HB-1]BRR	PEORIA & KNOX	115	27
CONTRACT NO. 68D48				
ILLINOIS FED. AID PROJECT				

MODEL: D:\info\ll FILE NAME: P:\2021\1122\IL - IL 78 over FAI 74 & Ch. 1B4 CADD - DWG\4.7\_TrimCAD\_Sheets\1468D48.dwg-eros-ll 78-03.dgn

MATCHLINE STA. 51+00.00

MATCHLINE STA. 57+00.00

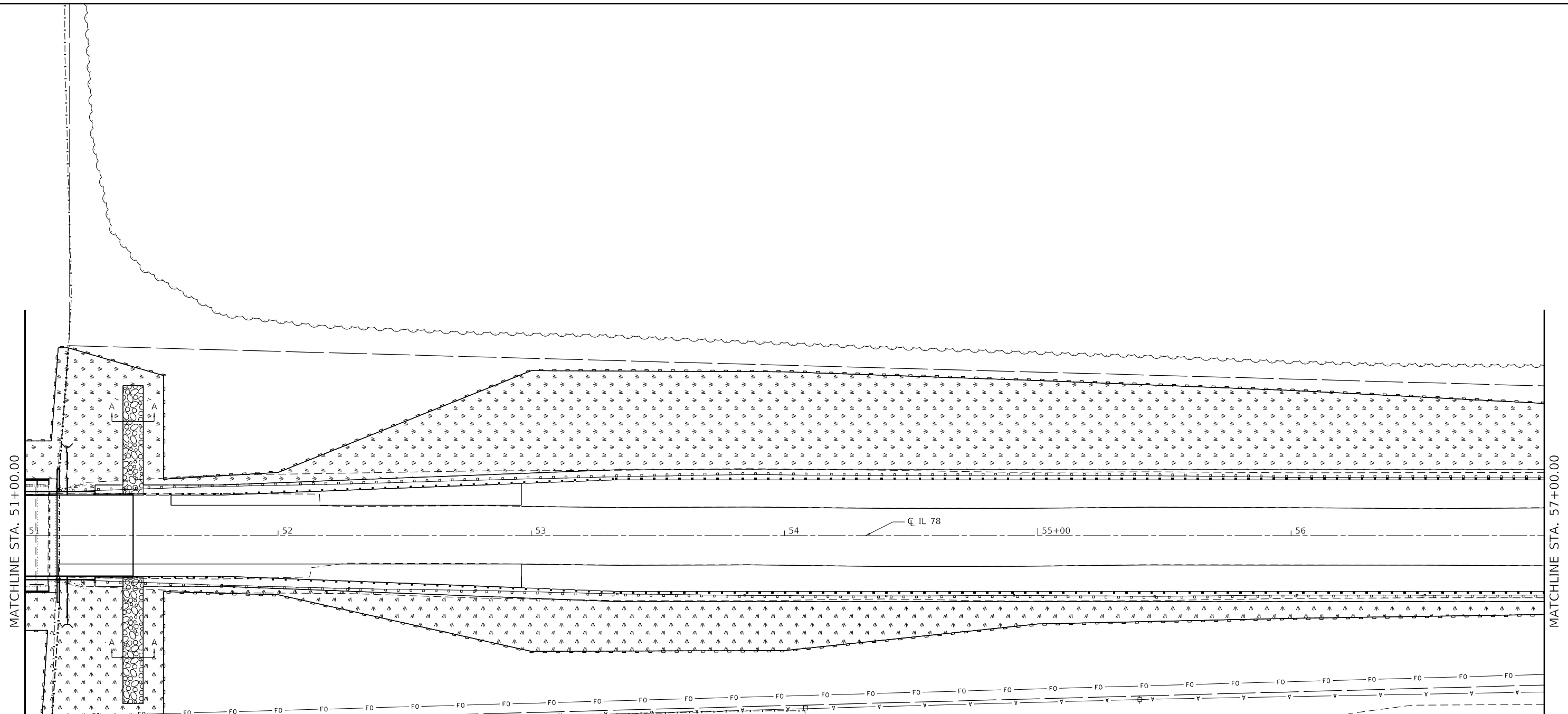

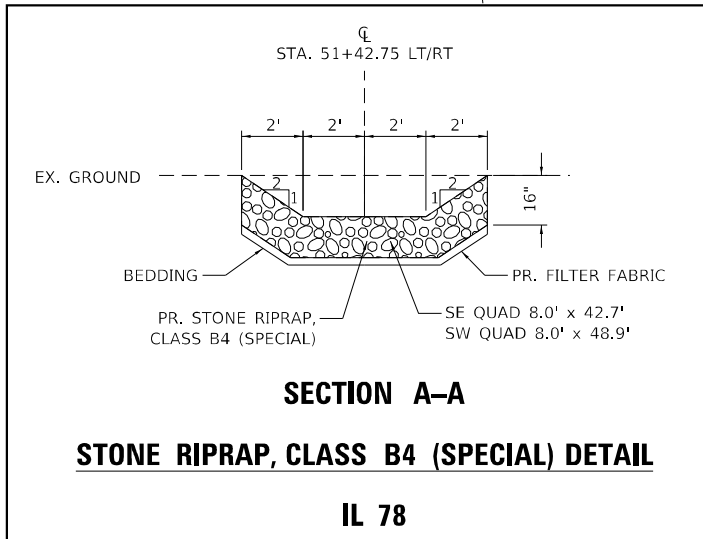

**NOTES:**

1. PLACE EROSION CONTROL BLANKET ON SLOPES FLATTER THAN 1:3
2. PLACE HEAVY DUTY EROSION CONTROL BLANKET ON SLOPES BETWEEN 1:3 AND 1:2

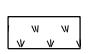
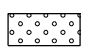

**LEGEND**

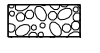
-  PR. SEEDING CLASS, 2A W/ FERTILIZER NUTRIENTS AND HEAVY-DUTY EROSION CONTROL BLANKET
-  PR. SEEDING CLASS, 2A W/ FERTILIZER NUTRIENTS AND EROSION CONTROL BLANKET
-  PR. INLET AND PIPE PROTECTION
-  PR. PERIMETER EROSION BARRIER
-  PR. STONE RIPRAP, CLASS B4 (SPECIAL)

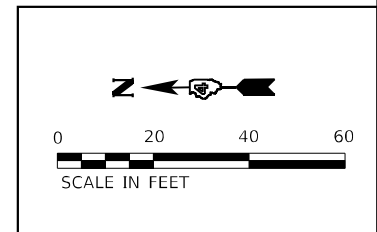

**TWM, INC.**  
www.twm-inc.com  
IL DESIGN FIRM  
LICENSE NO:  
184-001220

USER NAME = bbillhartz	DESIGNED -	REVISED -
PLOT SCALE = 40,0000' / in.	DRAWN -	REVISED -
PLOT DATE = 10/4/2023	CHECKED -	REVISED -
	DATE -	REVISED -

STATE OF ILLINOIS  
DEPARTMENT OF TRANSPORTATION

**EROSION CONTROL PLAN IL 78**

SCALE: 1"=20'

SHEET 3	OF 4 SHEETS	STA. 51+00.00	TO STA. 57+00.00
---------	-------------	---------------	------------------

F.A.I. RTE.	SECTION	COUNTY	TOTAL SHEETS	SHEET NO.
74	[(72-30;48-29)HB-1]BRR	PEORIA & KNOX	115	28
CONTRACT NO. 68D48				
ILLINOIS			FED. AID PROJECT	

MODEL: D:\p\h\l  
 FILE NAME: P:\2021\121122\1C - IL 78 over FAI 74 & CH 1B4 CADD - DWG\4.7 FromCAD\_Sheets\1468D48-eh-eros-IL 78-04.dgn

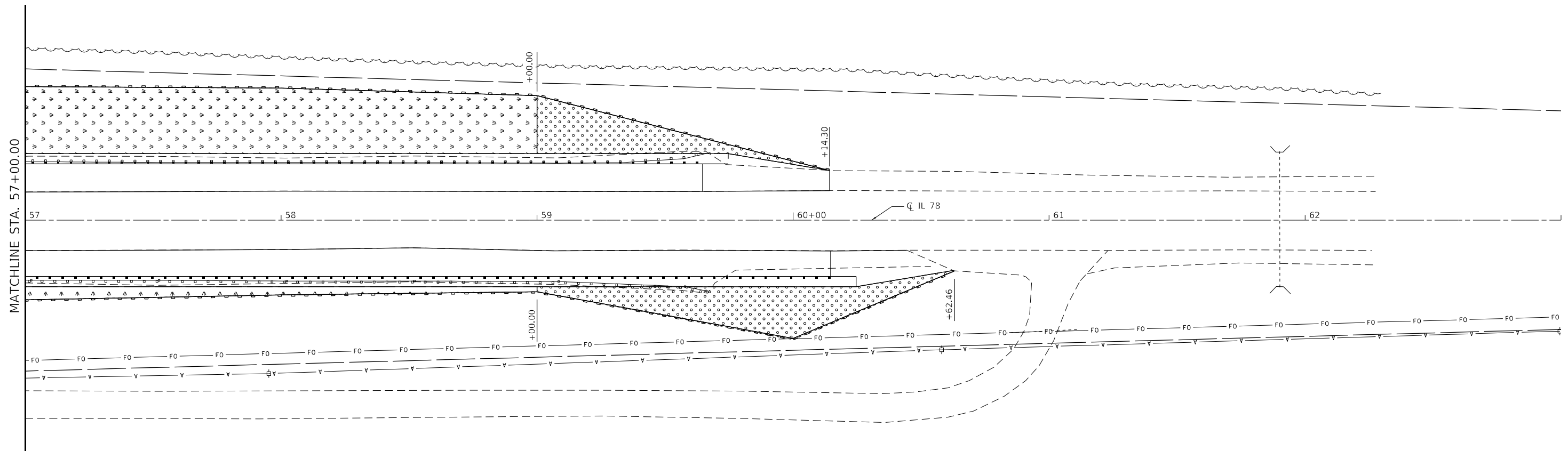

**NOTES:**

1. PLACE EROSION CONTROL BLANKET ON SLOPES FLATTER THAN 1:3
2. PLACE HEAVY DUTY EROSION CONTROL BLANKET ON SLOPES BETWEEN 1:3 AND 1:2

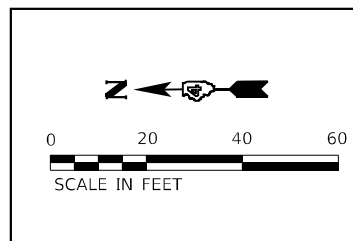

LEGEND	
	PR. SEEDING CLASS, 2A W/ FERTILIZER NUTRIENTS AND HEAVY-DUTY EROSION CONTROL BLANKET
	PR. SEEDING CLASS, 2A W/ FERTILIZER NUTRIENTS AND EROSION CONTROL BLANKET
	PR. INLET AND PIPE PROTECTION
	PR. PERIMETER EROSION BARRIER
	PR. STONE RIPRAP, CLASS B4 (SPECIAL)

**TWM, INC.**  
 ENGINEERING  
 GEOSPATIAL SERVICES  
 WWW.TWM-INC.COM  
 IL DESIGN FIRM  
 LICENSE NO:  
 184-001220

USER NAME = bbillhartz	DESIGNED -	REVISED -
PLOT SCALE = 40,0000 * / in.	DRAWN -	REVISED -
PLOT DATE = 10/4/2023	CHECKED -	REVISED -
	DATE -	REVISED -

**STATE OF ILLINOIS  
 DEPARTMENT OF TRANSPORTATION**

**EROSION CONTROL PLAN  
 IL 78**

SCALE: 1"=20'    SHEET 4    OF 4    SHEETS    STA. 57+00.00    TO STA. 63+00.00

F.A.I. RTE.	SECTION	COUNTY	TOTAL SHEETS	SHEET NO.
74	[(72-30;48-29)HB-1]BRR	PEORIA & KNOX	115	29
CONTRACT NO. 68D48				
ILLINOIS FED. AID PROJECT				

Bench Mark: Chiseled '+' on concrete pad for median impact attenuators, Elev. 696.86, Sta. 49+91, Offset 50.5' Lt.

Existing Structure: SN 072-0032 was originally built in 1967 over F.A.I. Route 74, Section 72-30HB-1. The structure is a four span continuous noncomposite steel wide flange beam bridge with a 7" reinforced concrete deck with a 1/2" membrane and 1 1/2" bituminous surface course. The overall length is 228'-0" back to back abutments and 36'-0" out to out. The structure is supported by two stub abutments supported by concrete piles and three hammerhead piers supported by creosoted timber piles. Deck is to be removed and replaced using stage construction to maintain one lane of traffic.

Salvage: None

**LOADING HS 20-44**

No allowance for future wearing surface.

**DESIGN SPECIFICATIONS**

2002 Standard Specifications for Highway Bridges, 17th Edition

**SEISMIC DATA**

Seismic Performance Category (SPC) = A  
Bedrock Acceleration Coefficient (A) = 0.040g  
Site Coefficient (S) = 1.5

**SCOPE OF WORK**

1. Remove and replace existing concrete deck and approach slabs.
2. Clean and paint top flange of beams. Zone clean and paint other areas as necessary.
3. Make new deck composite full length by installing shear studs.
4. Reconfigure existing abutments and wingwalls to semi-integral configuration.
5. Remove and replace all expansion bearings at abutments and Piers 1 and 3.
6. Remove and replace existing slopewalls.
7. Perform structural repair of concrete on piers.

**DESIGN STRESSES**

**FIELD UNITS (Ex. Const.)**

$f'_c = 3,500$  psi  
 $f_y = 40,000$  psi (Reinforcement)  
 $f_y = 36,000$  psi (Structural Steel)

**FIELD UNITS (New Const.)**

$f'_c = 3,500$  psi  
 $f'_c = 4,000$  psi (Concrete Superstructure)  
 $f_y = 60,000$  psi (Reinforcement)  
 $f_y = 36,000$  psi (M270 Grade 36)

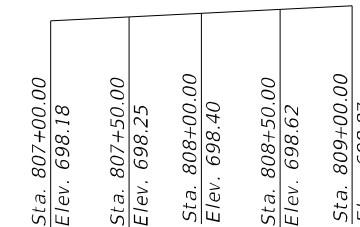

**PROFILE GRADE**

(Along  $\bar{C}$  E.B. and W.B. I-74)

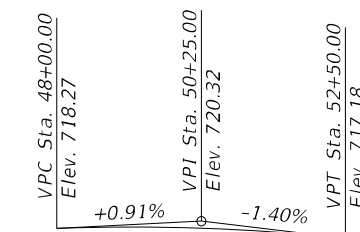

**PROFILE GRADE**

(Along  $\bar{C}$  IL 78)

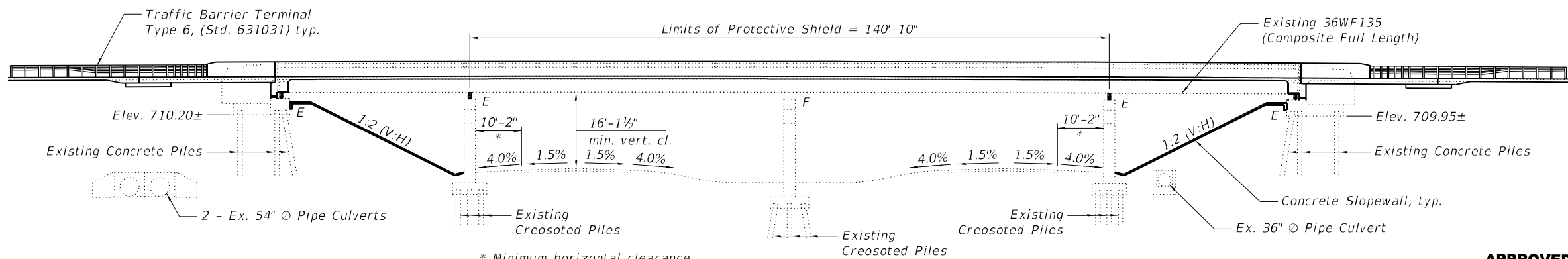

**ELEVATION**

**APPROVED**  
For Structural Adequacy Only  
Engineer of Bridges & Structures

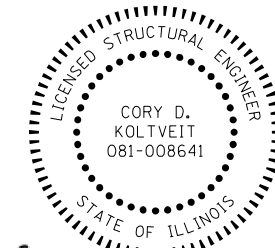

*Cory D. Koltveit*  
EXPIRES: 11/30/2024  
DATE: 11/30/2023

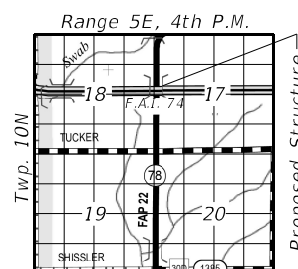

**LOCATION SKETCH**

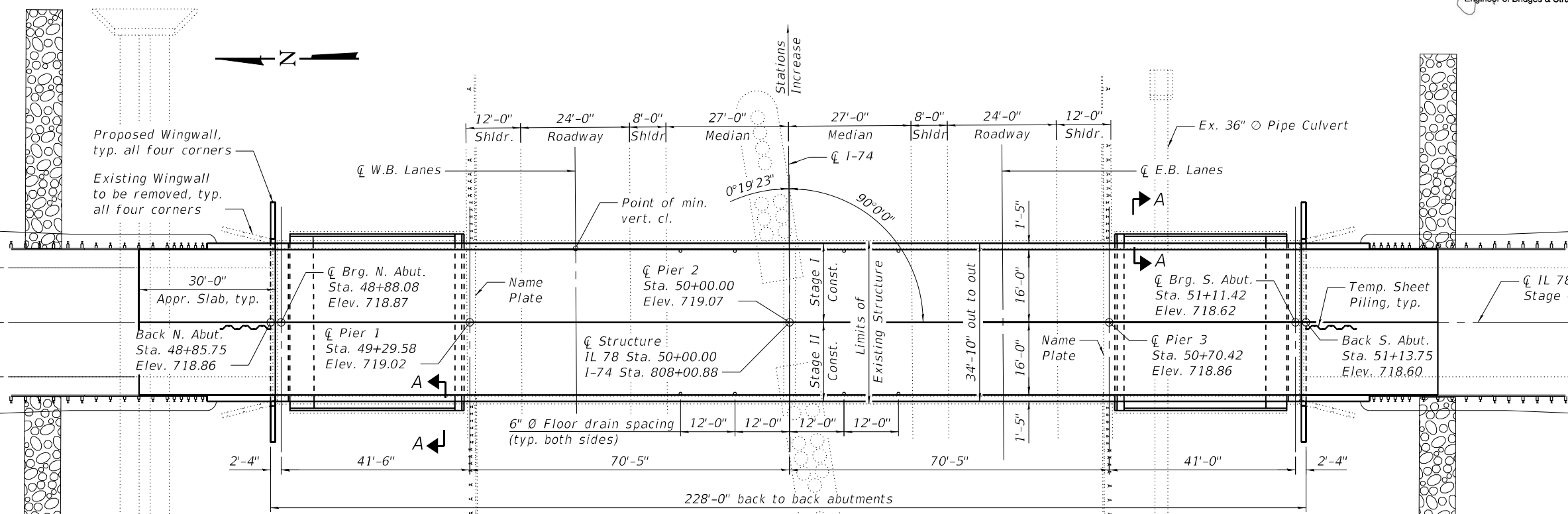

**PLAN**

**GENERAL PLAN & ELEVATION**  
**ILLINOIS ROUTE 78 OVER I-74**  
**F.A.I. RTE. 74 SEC. [(72-30;48-29)HB-1]BRR**

**PEORIA COUNTY**  
**STA. 808+00.88**  
**STRUCTURE NO. 072-0032**

MODEL: Default  
FILE NAME: P:\2022\121221\1C - IL 78 over FAL 74 & CH 184 CADD - DWG\4.4 - Struct\0720032-68D48-001-General Plan and Elevation.dgn



**TWM, INC.**  
www.twm-inc.com  
IL DESIGN FIRM LICENSE NO: 184-001220

USER NAME =	ckoltveit	DESIGNED -	JBE	REVISED -	
		CHECKED -	CDK	REVISED -	
PLOT SCALE =	0:2,0000 "/in.	DRAWN -	JBE	REVISED -	
PLOT DATE =	11/30/2023	CHECKED -	CDK	REVISED -	

**STATE OF ILLINOIS**  
**DEPARTMENT OF TRANSPORTATION**

**GENERAL PLAN & ELEVATION**  
**STRUCTURE NO. 072-0032**

SHEET 1 OF 25 SHEETS

F.A.I. RTE.	SECTION	COUNTY	TOTAL SHEETS	SHEET NO.
74	[(72-30;48-29)HB-1]BRR	PEORIA	115	30
CONTRACT NO. 68D48				
ILLINOIS FED. AID PROJECT				

**GENERAL NOTES**

No field welding is permitted except as specified in the contract documents.

The Contractor shall test the existing welds by non-destructive methods within 2 ft. of the end of the existing cover plates for cracks after removal of the existing concrete deck. Dye penetrant (PT), magnetic particle (MT), or other approved testing method shall be performed by qualified personnel approved by the Engineer. If cracks are found, report them to the Bureau of Bridges and Structures for disposition. The cost of testing is included in Removal of Existing Concrete Deck. The cost of crack repair, if necessary, will be paid for according to Article 109.04 of the Standard Specifications.

Reinforcement bars designated (E) shall be epoxy coated.

Prior to pouring the new concrete deck, all heavy or loose rust, loose mill scale, and other loose or potentially detrimental foreign material shall be removed from the surfaces in contact with concrete (SSPC - SP3 standards). Tightly adhered paint may remain unless otherwise noted. Removal shall be accomplished by methods that will not damage the steel and the cost will be paid for according to Article 109.04 of the Standard Specifications.

As directed by the Engineer, existing construction accessories welded to the top flange of beams and girders shall be removed. The weld areas shall be ground flush and inspected for cracks using magnetic particle testing (MT) or dye penetrant testing (PT) by qualified personnel approved by the Engineer. Any cracks that cannot be removed by grinding 1/4" inch deep shall be identified and reported to the Bureau of Bridges and Structures for further disposition. The cost of removing welded accessories, grinding and inspecting weld areas and grinding cracks will be paid for according to Article 109.04 of the Standard Specifications.

Plan dimensions and details relative to the existing structure have been taken from existing plans are subject to nominal construction variations. The Contractor shall field verify existing dimensions and details affecting new construction and make necessary approved adjustments prior to construction or ordering of materials. Such variations shall not be cause for additional compensation for a change in scope of the work, however, the Contractor will be paid for the quantity actually furnished at the unit price bid for the work.

The existing structural steel coating and bearings contain lead. The Contractor shall take appropriate precautions to deal with the presence of lead on this project.

Cleaning and painting of existing structural steel shall be as specified in the special provision for "Cleaning and Painting Existing Steel Structures". The entire top surface, edges, and undersides of the top flange of the girders shall be cleaned per Near White Blast Cleaning (SSPC-SP10) or Commercial Grade Power Tool Cleaning (SSPC-SP15).

The designated areas cleaned per Near White Blast Cleaning (SSPC-SP10) or Commercial Grade Power Tool Cleaning (SSPC-SP15) shall be painted according to the requirements of the Organic Zinc-Rich/Epoxy paint system. No finish coat is required. The color of the primer and intermediate coat shall be White.

Cleaning and painting shall be completed after the existing concrete deck has been removed and prior to final-grade placement of the formwork for the new concrete deck in order to access the edges of the top flange.

If the top flange is painted prior to installing shear studs any paint removed to facilitate installation of the shear studs shall be touched up with zinc-rich primer.

A minimum of one air monitor will be required to monitor abrasive blasting operations at this site. See special provision for "Containment and Disposal of Lead Paint Cleaning Residues."

SSPC QP1 and QP2 Certification is required for this contract.

**INDEX OF SHEETS**

- 1 General Plan and Elevation
- 2 General Data
- 3 Temporary Sheet Piling
- 4 Stage Construction Details
- 5 Temporary Concrete Barrier
- 6-8 Top of Slab Elevations
- 9 Top of North Approach Slab Elevations
- 10 Top of South Approach Slab Elevations
- 11 Superstructure
- 12 Superstructure Details
- 13 Diaphragm Details
- 14-15 Bridge Approach Slab Details
- 16 Structural Steel
- 17 Structural Steel Details
- 18 Abutment Bearing Details
- 19 Pier 1 and Pier 3 Bearing Details
- 20 Abutment Removal Details
- 21 North Abutment
- 22 South Abutment
- 23 Pier 1 and Pier 2 Repair Details
- 24 Concrete Parapet Slipforming Option
- 25 Bar Splicer Assembly Details

STATION 808+00.88  
 RE-BUILT 202\_ BY  
 STATE OF ILLINOIS  
 F.A.I. RTE. 74  
 SEC. [(72-30;48-29)HB-1]BRR  
 LOADING HS-20  
 STRUCTURE NO. 072-0032

**NAME PLATE**  
 See Std. 515001

The new name plate shall be located near the existing name plate on Piers 1 & 3.

**TOTAL BILL OF MATERIAL**

ITEM	UNIT	SUPER	SUB	TOTAL
Concrete Removal	Cu. Yd.		39.3	39.3
Slope Wall Removal	Sq. Yd.		410	410
Removal of Existing Concrete Deck No. 1	Each	1		1
Protective Shield	Sq. Yd.	564		564
Structure Excavation	Cu. Yd.		172	172
Floor Drains	Each	8		8
Concrete Structures	Cu. Yd.		30.6	30.6
Concrete Superstructure	Cu. Yd.	314.5		314.5
Bridge Deck Grooving	Sq. Yd.	952		952
Protective Coat	Sq. Yd.	1,255		1,255
Concrete Superstructure (Approach Slab)	Cu. Yd.	94.6		94.6
Furnishing and Erecting Structural Steel	Pound	4,700		4,700
Stud Shear Connectors	Each	3,888		3,888
Reinforcement Bars, Epoxy Coated	Pound	107,760	5,490	113,250
Bar Splicers	Each	909	84	993
Slope Wall 4 Inch	Sq. Yd.		362	362
Name Plates	Each		2	2
Elastomeric Bearing Assembly, Type 1	Each	24		24
Anchor Bolts, 5/8"	Each	48		48
Anchor Bolts, 1"	Each	24		24
Temporary Sheet Piling	Sq. Ft.		513	513
Granular Backfill for Structures	Cu. Yd.		151	151
Geocomposite Wall Drain	Sq. Yd.		77	77
Pipe Underdrains for Structures 4"	Foot		143	143
Jack and Remove Existing Bearings	Each	24		24
Containment and Disposal of Lead Paint Cleaning Residues No. 1	L Sum	1		1
Cleaning and Painting Steel Bridge No. 1	L Sum	1		1
Structural Repair of Concrete (Depth Equal to or Less Than 5 inches)	Sq. Ft.		4	4

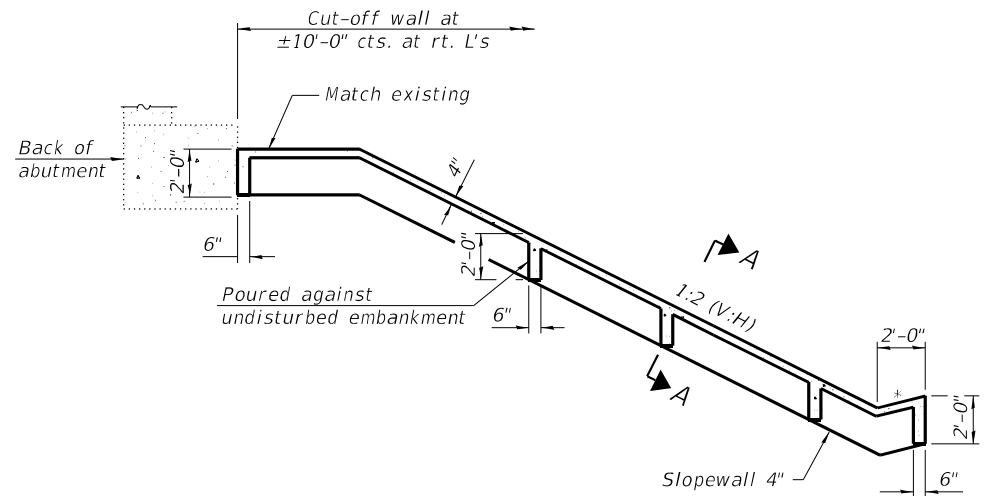

**SECTION THRU CONCRETE SLOPEWALL EXTENSION**

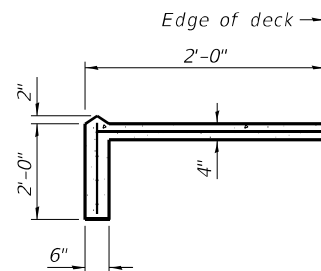

**SECTION A-A**

Note:  
 Slope wall shall be reinforced with galvanized welded wire fabric, 6 in. x 6 in. - W4.0 x W4.0, weighing 58 lbs. per 100 sq. ft.

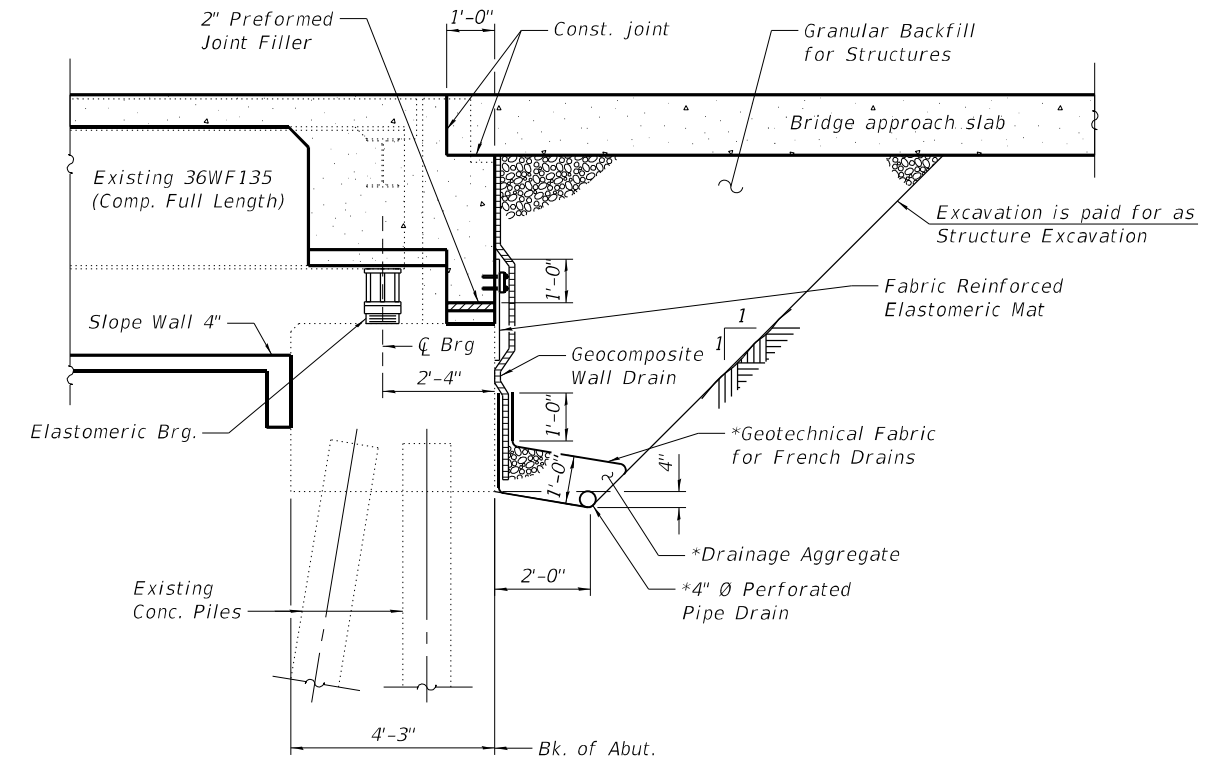

**SECTION THRU SEMI-INTEGRAL ABUTMENT**

\*Included in the cost of Pipe Underdrains for Structures

Note:  
 All drainage system components shall extend to 2'-0" from the end of each wingwall except an outlet pipe shall extend until intersecting with the side slopes. The pipes shall drain into concrete headwalls. (See Article 601.05 of the Standard Specifications and Highway Standard 601101).

MODEL: Default  
 FILE NAME: P:\2021\121122\1C - IL 78 over FAI 74 & CH 18\4 CADD - DWG\4.4 - Struc\0720032-68D48-002-General Data.dgn



USER NAME = cktovell	DESIGNED - JBE	REVISED -
PLOT SCALE = 0:2,0000 "/>		

**STATE OF ILLINOIS  
 DEPARTMENT OF TRANSPORTATION**

**GENERAL DATA  
 STRUCTURE NO. 072-0032**

SHEET 2 OF 25 SHEETS

F.A.I. RTE.	SECTION	COUNTY	TOTAL SHEETS	SHEET NO.
74	[(72-30;48-29)HB-1]BRR	PEORIA	115	31
CONTRACT NO. 68D48				
ILLINOIS FED. AID PROJECT				

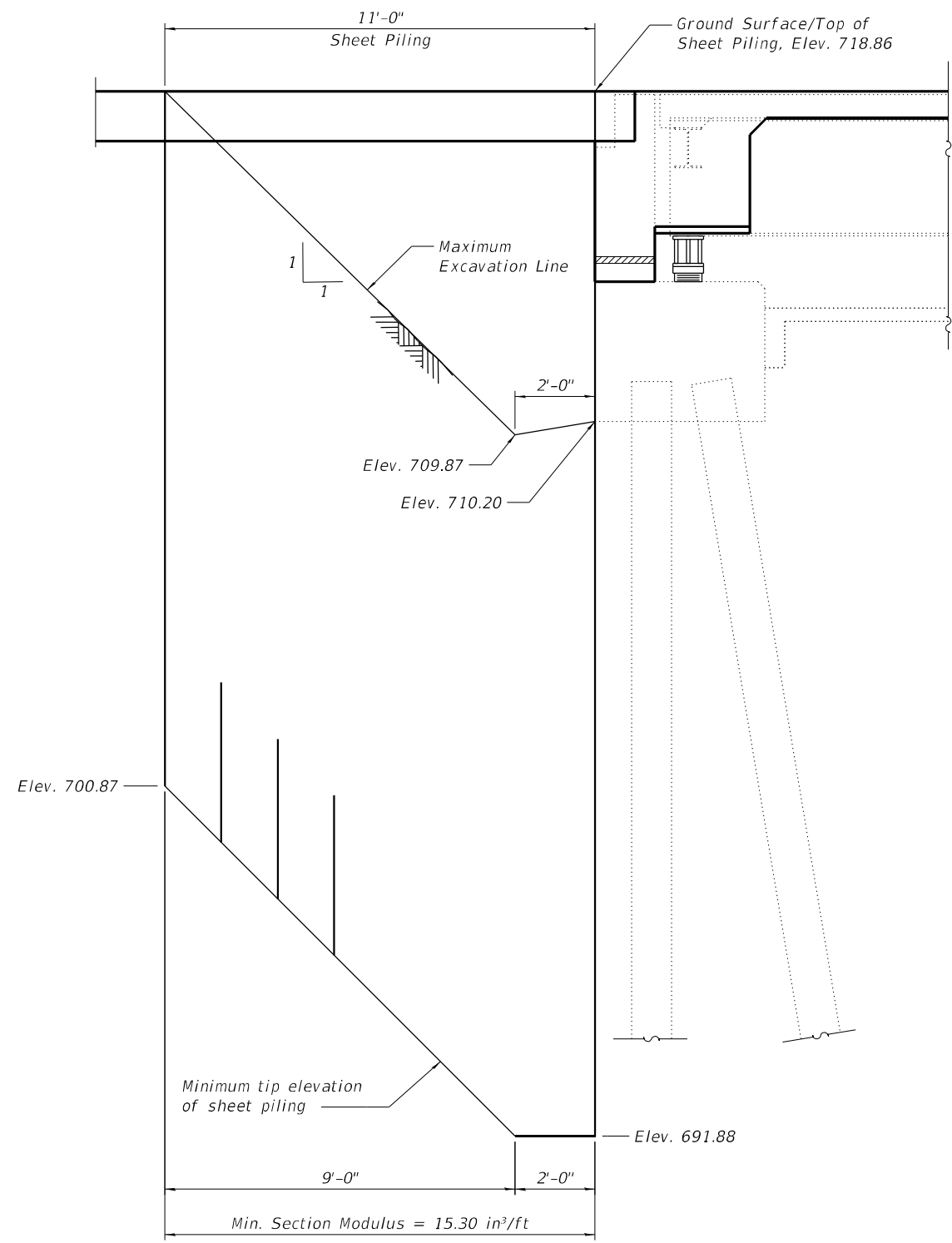

**NORTH ABUTMENT  
TEMPORARY SHEET PILING**  
(Looking East)

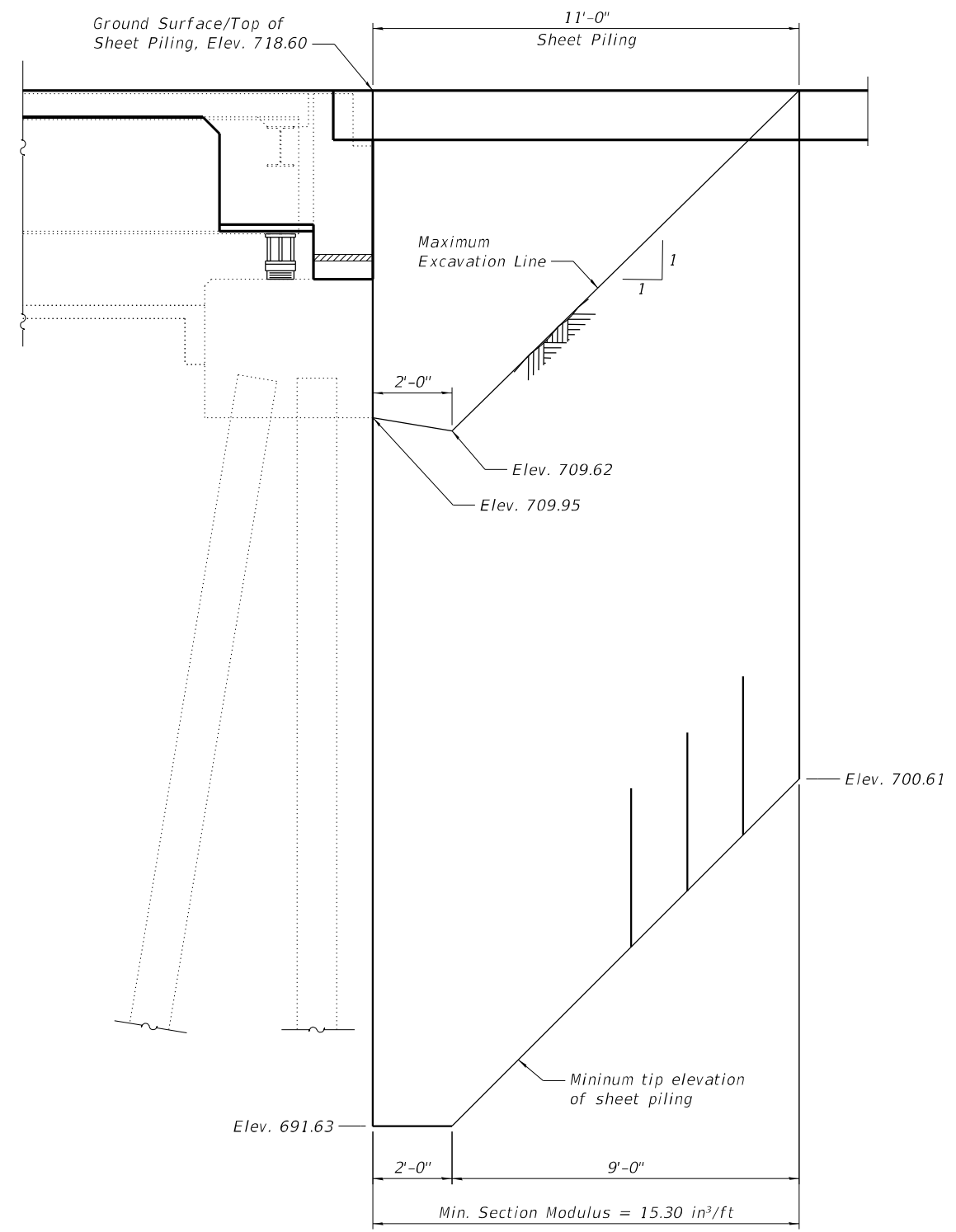

**SOUTH ABUTMENT  
TEMPORARY SHEET PILING**  
(Looking East)

If the Contractor chooses to alter the temporary cantilevered sheet piling design requirements shown on the plans, a design submittal including plan details and calculations will be required for review and acceptance by the Engineer.

MODEL: Default  
FILE NAME: \\110.0.0.90\Projects\2021\11221\11221\C - IL 78 over FAI 74 & CH 184 CADD - DWG\4.4 - Struct\0720032-68D48-003-Temporary Sheet Piling.dgn



USER NAME =	ckotveit	DESIGNED -	JBE	REVISED -	
		CHECKED -	CDK	REVISED -	
PLOT SCALE =	0:2,0000 "/ in.	DRAWN -	JBE	REVISED -	
PLOT DATE =	9/22/2023	CHECKED -	CDK	REVISED -	

**STATE OF ILLINOIS  
DEPARTMENT OF TRANSPORTATION**

**TEMPORARY SHEET PILING  
STRUCTURE NO. 072-0032**

SHEET 3 OF 25 SHEETS

F.A.I. RTE.	SECTION	COUNTY	TOTAL SHEETS	SHEET NO.
74	[(72-30;48-29)HB-1]BRR	PEORIA	115	32
			CONTRACT NO. 68D48	
ILLINOIS FED. AID PROJECT				



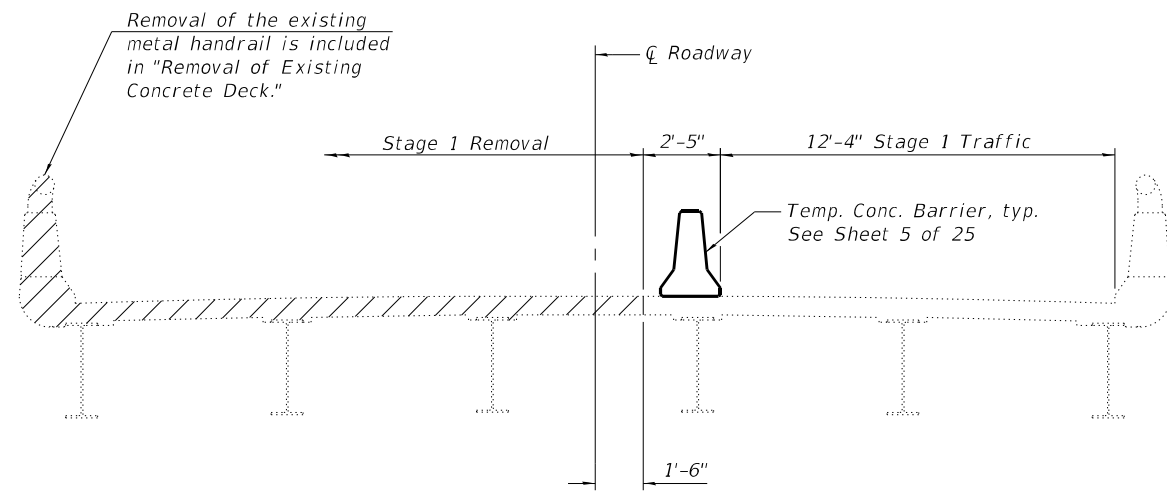

**STAGE I REMOVAL**  
(Looking South)

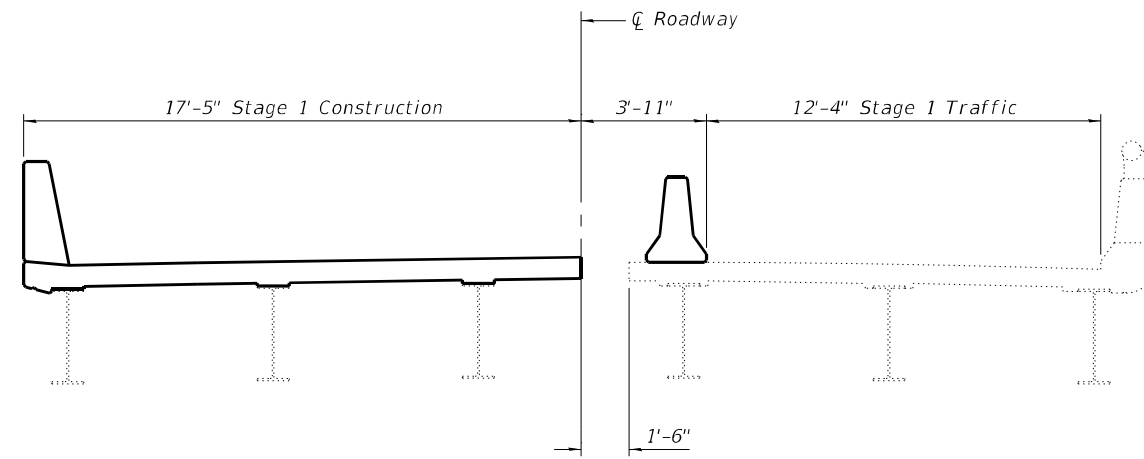

**STAGE I CONSTRUCTION**  
(Looking South)

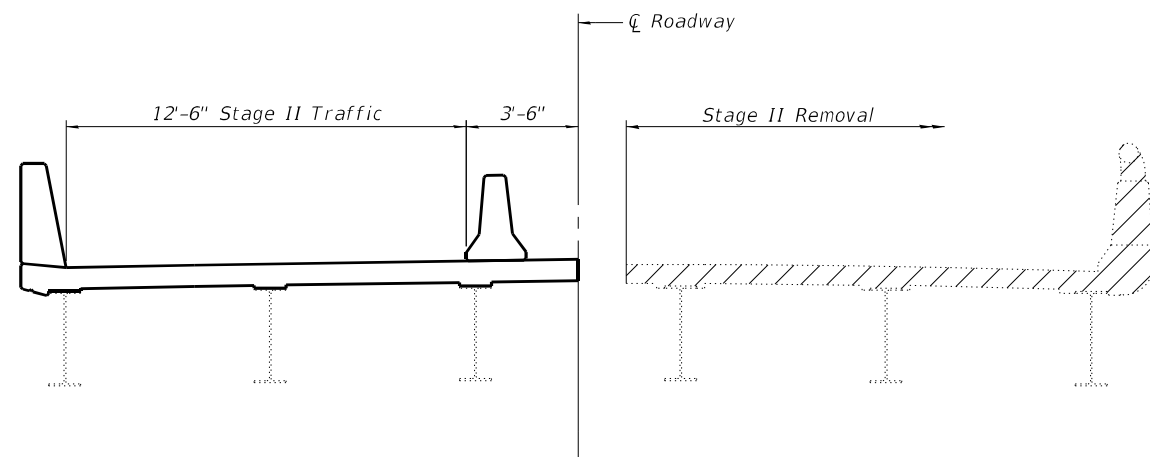

**STAGE II REMOVAL**  
(Looking South)

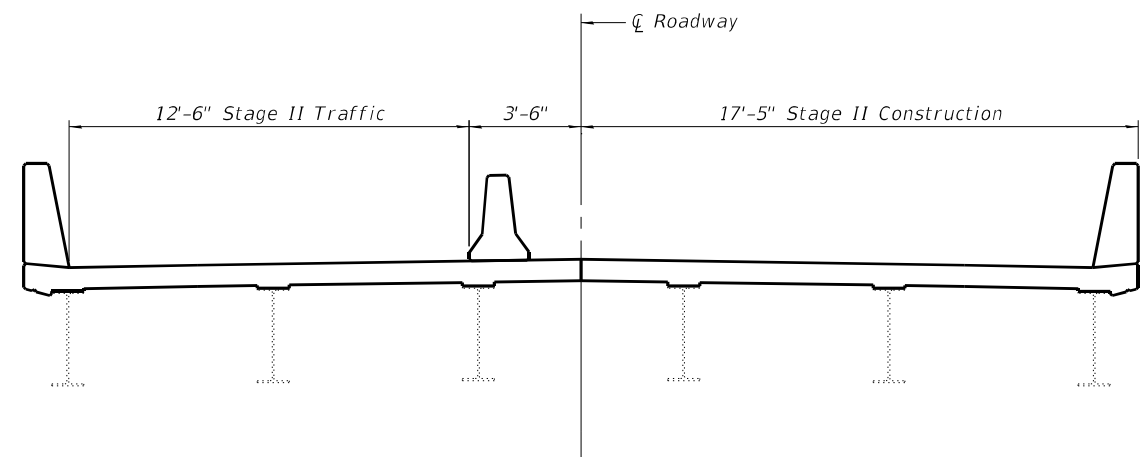

**STAGE II CONSTRUCTION**  
(Looking South)

MODEL: Default  
FILE NAME: \\10.0.0.90\Projects\2021\121211C - IL 78 over FAI 74 & CH 184 CADD - DWG\4.4 - Struct\0720032-68D48-004-Stage Construction Details.dgn



**TWM, INC.**  
WWW.TWM-INC.COM  
IL DESIGN FIRM  
LICENSE NO:  
184-001220

USER NAME = cktovell  
DESIGNED - JBE  
CHECKED - CDK  
DRAWN - JBE  
CHECKED - CDK  
PLOT SCALE = 0:2,0000 "/>

DESIGNED - JBE  
CHECKED - CDK  
DRAWN - JBE  
CHECKED - CDK  
PLOT DATE = 9/22/2023

REVISED -  
REVISED -  
REVISED -  
REVISED -

**STATE OF ILLINOIS  
DEPARTMENT OF TRANSPORTATION**

**STAGE CONSTRUCTION DETAILS  
STRUCTURE NO. 072-0032**

SHEET 4 OF 25 SHEETS

F.A.I. RTE.	SECTION	COUNTY	TOTAL SHEETS	SHEET NO.
74	[(72-30;48-29)HB-1]BRR	PEORIA	115	33
			CONTRACT NO. 68D48	
		ILLINOIS	FED. AID PROJECT	

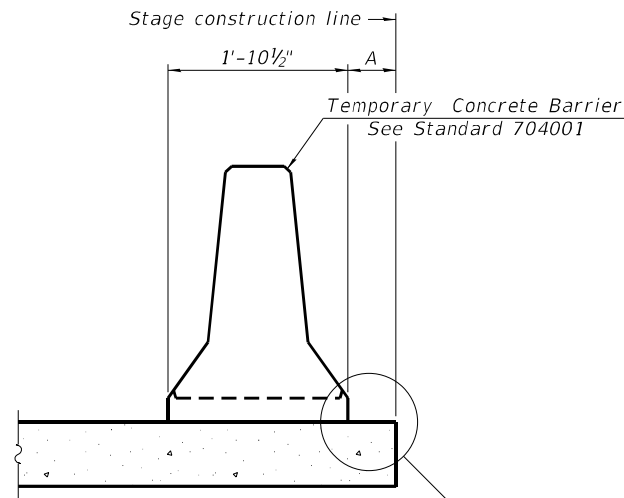

When "A" is 3'-1" or less, the temporary concrete barrier shall be restrained to the new slab according to Detail I, II or III. No restraint is required when "A" is greater than 3'-1".

NEW SLAB OR NEW DECK BEAM

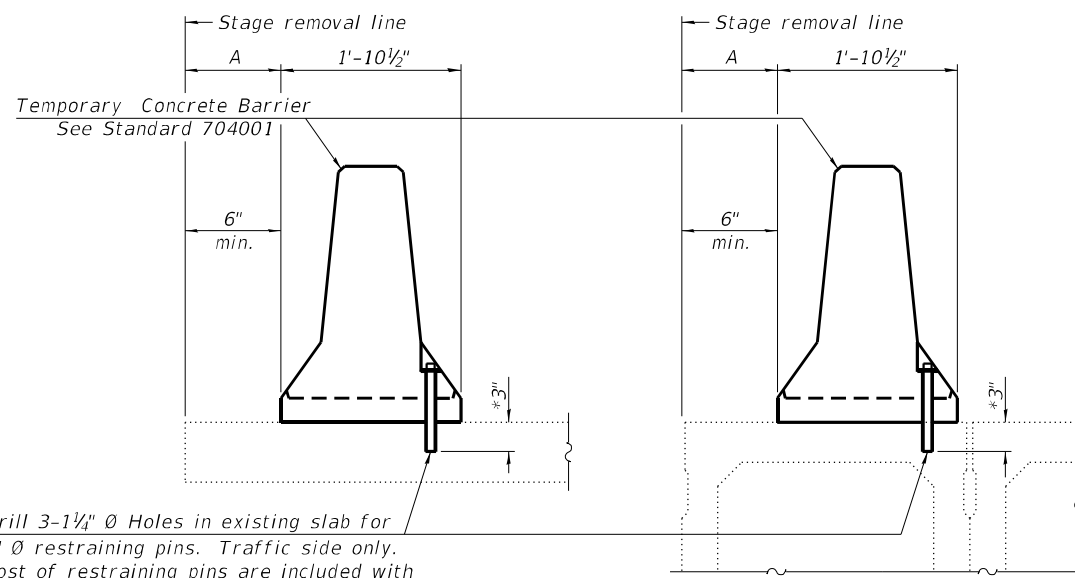

Drill 3-1/4" Ø Holes in existing slab for 1" Ø restraining pins. Traffic side only. Cost of restraining pins are included with Temporary Concrete Barrier. No restraint is required when "A" is greater than 3'-1".

EXISTING SLAB

\* When hot-mix asphalt wearing surface is present, embedment shall be 3" plus the wearing surface depth.

EXISTING DECK BEAM

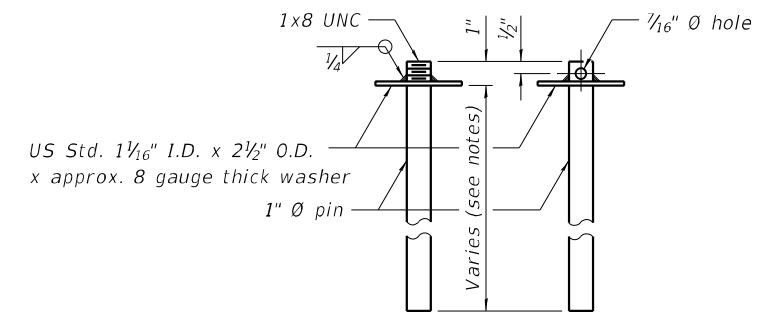

RESTRAINING PIN

SECTIONS THRU SLAB OR DECK BEAM

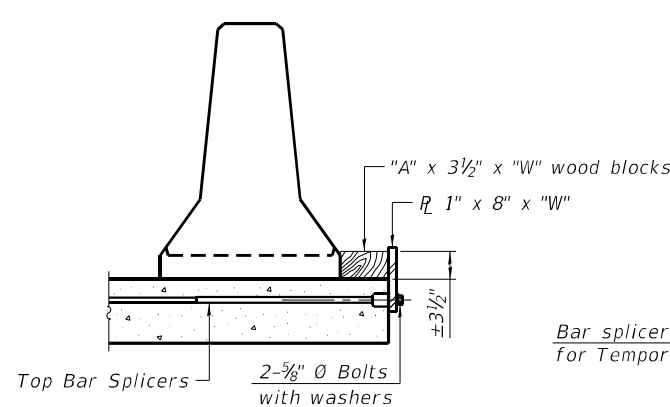

DETAIL I

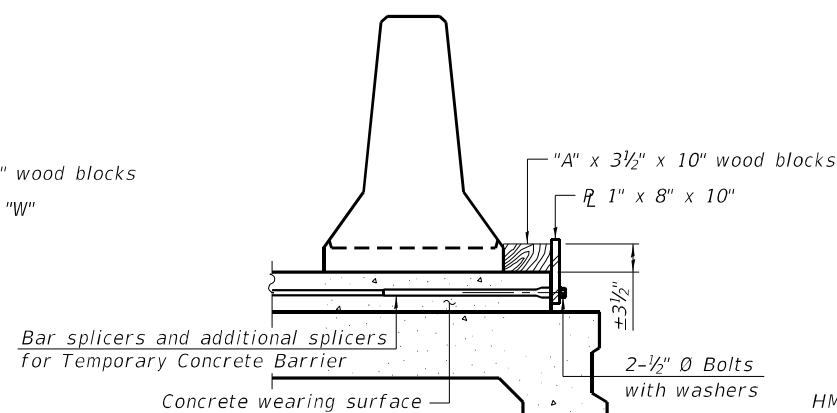

DETAIL II

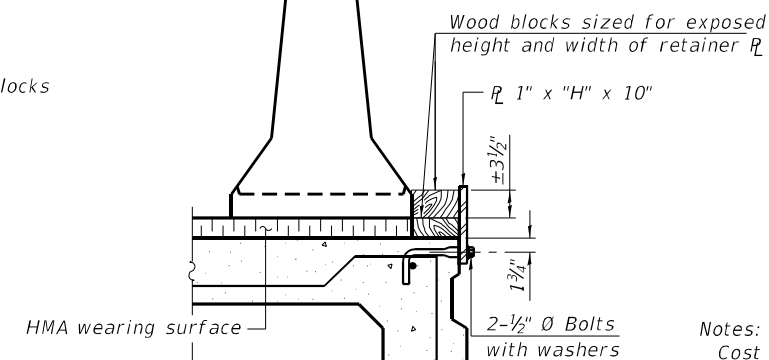

DETAIL III

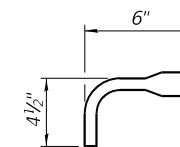

BAR SPLICER FOR #4 BAR - DETAIL III

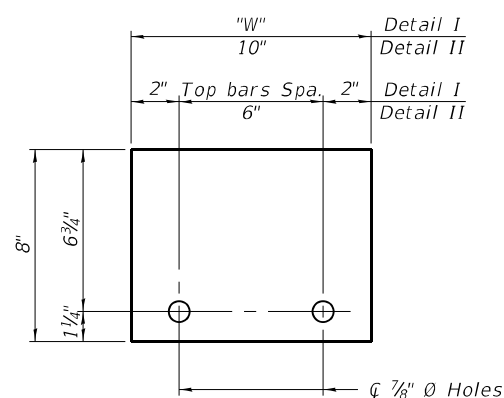

STEEL RETAINER R 1" x 8" x "W"  
(Detail I and II)

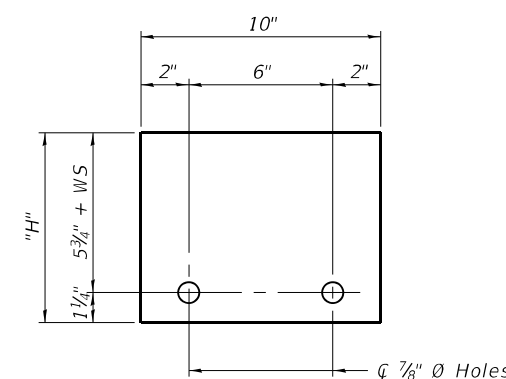

STEEL RETAINER R 1" x "H" x 10"  
(Detail III)

Notes:

- Cost of retainer assembly is included with Temporary Concrete Barrier.
- A retainer assembly shall be located at the approximate  $\frac{1}{2}$  of each temporary concrete barrier.
- The retainer plate shall not be removed until the concrete on the adjacent stage is ready to be poured. For Detail III applications the retainer plate shall not be removed until just prior to placing the adjacent beam.
- When the 'A' dimension is less than 1 1/2', the wood block shall be omitted and the barrier shall be placed in direct contact with the steel retainer plate.
- For deck beam applications the minimum required 'A' distance is 6" to accommodate the shear key clamping device.

Detail I - Installation for a new bridge deck or bridge slab.

Detail II - Installation for a new deck beam with an initial concrete wearing surface. Additional bar splicers shall be provided at 6'-0" centers and paired with the bar splicers of the concrete wearing surface reinforcement to accommodate the installation of the retainer assemblies. The cost of the additional bar splicers is included with the concrete wearing surface.

Detail III - Installation for a new deck beam with no initial wearing surface or with an initial hot-mix asphalt (HMA) wearing surface present. The deck beam directly beneath the temporary concrete barrier shall be fabricated with bar splicer inserts in the side of the beam, as detailed, to accommodate the installation of the retainer assemblies. A pair of bar splicers, 6" apart, shall be placed at 6'-0" centers along the length of the beam. The cost of the bar splicers is included with the deck beam.

RAILING CRITERIA

NCHRP 350 Test Level	3
Railing Weight (plf)	440

R-27 10-12-2021

STATE OF ILLINOIS  
DEPARTMENT OF TRANSPORTATION

TEMPORARY CONCRETE BARRIER  
STRUCTURE NO. 072-0032

SHEET 5 OF 25 SHEETS

F.A.I. RTE.	SECTION	COUNTY	TOTAL SHEETS	SHEET NO.
74	[(72-30;48-29)HB-1]BRR	PEORIA	115	34
CONTRACT NO. 68D48				

ILLINOIS FED. AID PROJECT

MODEL: Default  
 FILE NAME: \\110.0.0.90\Projects\2021\112121\112121\C - IL 78 over FAI 74 & CH 18\4 CADD - DWG\4.4 - Struct\0720032-68D48-006-Top of Slab Elevations.dgn

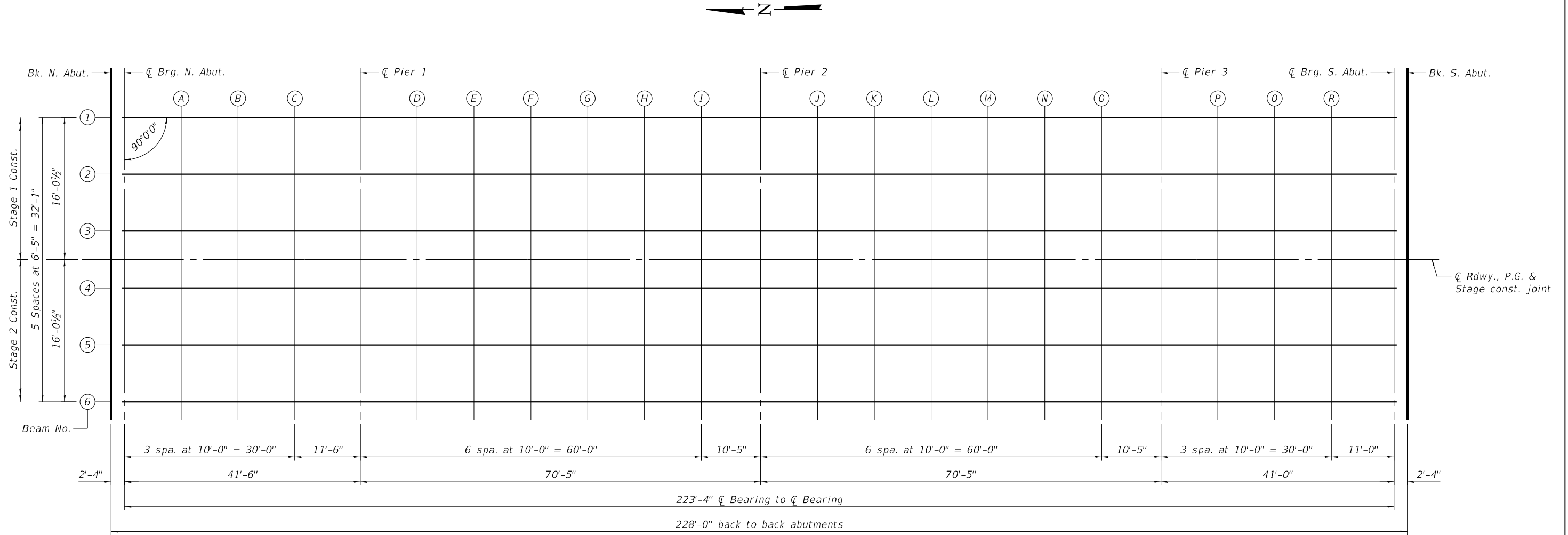

PLAN



**TWM, INC.**  
 www.twm-inc.com  
 IL DESIGN FIRM  
 LICENSE NO:  
 184-001220

USER NAME =	ckotveit	DESIGNED -	JBE	REVISED -	
		CHECKED -	CDK	REVISED -	
PLOT SCALE =	0:2.0000 " / in.	DRAWN -	JBE	REVISED -	
PLOT DATE =	9/22/2023	CHECKED -	CDK	REVISED -	

**STATE OF ILLINOIS  
 DEPARTMENT OF TRANSPORTATION**

**TOP OF SLAB ELEVATIONS  
 STRUCTURE NO. 072-0032**

SHEET 6 OF 25 SHEETS

F.A.I. RTE.	SECTION	COUNTY	TOTAL SHEETS	SHEET NO.
74	[(72-30;48-29)HB-1]BRR	PEORIA	115	35
			CONTRACT NO. 68D48	
		ILLINOIS FED. AID PROJECT		

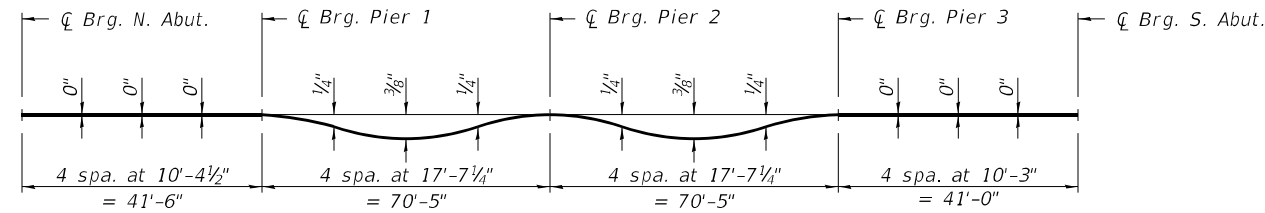

**DEAD LOAD DEFLECTION DIAGRAM**  
(Includes weight of concrete only.)

Note:  
The above deflections are not to be used in the field if the engineer is working from the grade elevations adjusted for dead load deflections as shown below and on sheet 8 of 25.

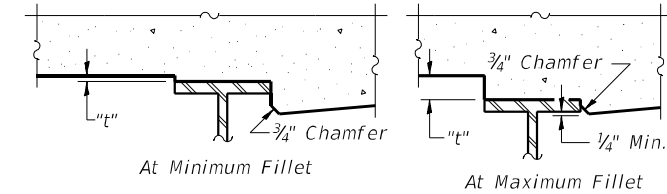

To determine "t": After all structural steel has been erected, elevations of the top flanges of the beams shall be taken at intervals shown on sheet 6 of 25. These elevations subtracted from the "Theoretical Grade Elevations Adjusted for Dead Load Deflection" shown below and on sheet 8 of 25, minus slab thickness, equals the fillet heights "t"

**FILLET HEIGHTS**

**BEAM 1**

Location	Station	Offset	Theoretical Grade Elevations	Theoretical Grade Elevations Adjusted for Dead Load Deflection
Bk. N. Abut.	48+85.75	-16.04	718.60	718.60
☐ Brg. N. Abut.	48+88.08	-16.04	718.61	718.61
A	48+98.08	-16.04	718.66	718.66
B	49+08.08	-16.04	718.70	718.70
C	49+18.08	-16.04	718.73	718.73
☐ Brg. Pier 1	49+29.58	-16.04	718.76	718.76
D	49+39.58	-16.04	718.78	718.79
E	49+49.58	-16.04	718.80	718.83
F	49+59.58	-16.04	718.81	718.85
G	49+69.58	-16.04	718.82	718.85
H	49+79.58	-16.04	718.82	718.84
I	49+89.58	-16.04	718.81	718.82
☐ Brg. Pier 2	50+00.00	-16.04	718.81	718.81
J	50+10.00	-16.04	718.79	718.80
K	50+20.00	-16.04	718.77	718.79
L	50+30.00	-16.04	718.75	718.78
M	50+40.00	-16.04	718.72	718.75
N	50+50.00	-16.04	718.68	718.71
O	50+60.00	-16.04	718.64	718.66
☐ Brg. Pier 3	50+70.42	-16.04	718.60	718.60
P	50+80.42	-16.04	718.55	718.54
Q	50+90.42	-16.04	718.49	718.49
R	51+00.42	-16.04	718.43	718.43
☐ Brg. S. Abut.	51+11.42	-16.04	718.36	718.36
Bk. S. Abut.	51+13.75	-16.04	718.34	718.34

**BEAM 2**

Location	Station	Offset	Theoretical Grade Elevations	Theoretical Grade Elevations Adjusted for Dead Load Deflection
Bk. N. Abut.	48+85.75	-9.63	718.72	718.72
☐ Brg. N. Abut.	48+88.08	-9.63	718.73	718.73
A	48+98.08	-9.63	718.77	718.78
B	49+08.08	-9.63	718.81	718.81
C	49+18.08	-9.63	718.84	718.84
☐ Brg. Pier 1	49+29.58	-9.63	718.88	718.88
D	49+39.58	-9.63	718.90	718.91
E	49+49.58	-9.63	718.92	718.94
F	49+59.58	-9.63	718.93	718.96
G	49+69.58	-9.63	718.93	718.97
H	49+79.58	-9.63	718.93	718.96
I	49+89.58	-9.63	718.93	718.94
☐ Brg. Pier 2	50+00.00	-9.63	718.92	718.92
J	50+10.00	-9.63	718.91	718.92
K	50+20.00	-9.63	718.89	718.91
L	50+30.00	-9.63	718.86	718.90
M	50+40.00	-9.63	718.83	718.87
N	50+50.00	-9.63	718.80	718.83
O	50+60.00	-9.63	718.76	718.77
☐ Brg. Pier 3	50+70.42	-9.63	718.71	718.71
P	50+80.42	-9.63	718.66	718.66
Q	50+90.42	-9.63	718.61	718.61
R	51+00.42	-9.63	718.55	718.55
☐ Brg. S. Abut.	51+11.42	-9.63	718.47	718.47
Bk. S. Abut.	51+13.75	-9.63	718.46	718.46

**BEAM 3**

Location	Station	Offset	Theoretical Grade Elevations	Theoretical Grade Elevations Adjusted for Dead Load Deflection
Bk. N. Abut.	48+85.75	-3.21	718.82	718.82
☐ Brg. N. Abut.	48+88.08	-3.21	718.83	718.83
A	48+98.08	-3.21	718.87	718.87
B	49+08.08	-3.21	718.91	718.91
C	49+18.08	-3.21	718.94	718.94
☐ Brg. Pier 1	49+29.58	-3.21	718.97	718.97
D	49+39.58	-3.21	718.99	719.01
E	49+49.58	-3.21	719.01	719.04
F	49+59.58	-3.21	719.02	719.06
G	49+69.58	-3.21	719.03	719.06
H	49+79.58	-3.21	719.03	719.05
I	49+89.58	-3.21	719.03	719.04
☐ Brg. Pier 2	50+00.00	-3.21	719.02	719.02
J	50+10.00	-3.21	719.00	719.01
K	50+20.00	-3.21	718.98	719.01
L	50+30.00	-3.21	718.96	718.99
M	50+40.00	-3.21	718.93	718.97
N	50+50.00	-3.21	718.90	718.92
O	50+60.00	-3.21	718.86	718.87
☐ Brg. Pier 3	50+70.42	-3.21	718.81	718.81
P	50+80.42	-3.21	718.76	718.76
Q	50+90.42	-3.21	718.70	718.70
R	51+00.42	-3.21	718.64	718.64
☐ Brg. S. Abut.	51+11.42	-3.21	718.57	718.57
Bk. S. Abut.	51+13.75	-3.21	718.55	718.55

MODEL: Default  
FILE NAME: \\110.0.0.90\Projects\2021\121211C - IL 78 over FAI 74 & CH 18\4 CADD - DWG\4.4 - Struct\0720032-68D48-007-Top of Slab Elevations.dgn

E-S 2-17-2017



**TWM, INC.**  
www.twm-inc.com  
IL DESIGN FIRM LICENSE NO: 184-001220

USER NAME =	ckotveit	DESIGNED -	JBE	REVISED -	
CHECKED -	CDK	CHECKED -	CDK	REVISED -	
PLOT SCALE =	0:2,0000 "/ in.	DRAWN -	JBE	REVISED -	
PLOT DATE =	9/22/2023	CHECKED -	CDK	REVISED -	

STATE OF ILLINOIS  
DEPARTMENT OF TRANSPORTATION

TOP OF SLAB ELEVATIONS  
STRUCTURE NO. 072-0032

SHEET 7 OF 25 SHEETS

F.A.I. RTE.	SECTION	COUNTY	TOTAL SHEETS	SHEET NO.
74	[(72-30;48-29)HB-1]BRR	PEORIA	115	36
CONTRACT NO. 68D48				
ILLINOIS FED. AID PROJECT				

☐ ROADWAY, P.G. & STAGE CONST. JOINT

Location	Station	Offset	Theoretical Grade Elevations	Theoretical Grade Elevations Adjusted for Dead Load Deflection
Bk. N. Abut.	48+85.75	0.00	718.86	718.86
☐ Brg. N. Abut.	48+88.08	0.00	718.87	718.87
A	48+98.08	0.00	718.92	718.92
B	49+08.08	0.00	718.96	718.96
C	49+18.08	0.00	718.99	718.99
☐ Brg. Pier 1	49+29.58	0.00	719.02	719.02
D	49+39.58	0.00	719.04	719.06
E	49+49.58	0.00	719.06	719.09
F	49+59.58	0.00	719.07	719.11
G	49+69.58	0.00	719.08	719.11
H	49+79.58	0.00	719.08	719.10
I	49+89.58	0.00	719.08	719.08
☐ Brg. Pier 2	50+00.00	0.00	719.07	719.07
J	50+10.00	0.00	719.05	719.06
K	50+20.00	0.00	719.03	719.06
L	50+30.00	0.00	719.01	719.04
M	50+40.00	0.00	718.98	719.01
N	50+50.00	0.00	718.94	718.97
O	50+60.00	0.00	718.90	718.92
☐ Brg. Pier 3	50+70.42	0.00	718.86	718.86
P	50+80.42	0.00	718.81	718.80
Q	50+90.42	0.00	718.75	718.75
R	51+00.42	0.00	718.69	718.69
☐ Brg. S. Abut.	51+11.42	0.00	718.62	718.62
Bk. S. Abut.	51+13.75	0.00	718.60	718.60

BEAM 4

Location	Station	Offset	Theoretical Grade Elevations	Theoretical Grade Elevations Adjusted for Dead Load Deflection
Bk. N. Abut.	48+85.75	3.21	718.82	718.82
☐ Brg. N. Abut.	48+88.08	3.21	718.83	718.83
A	48+98.08	3.21	718.87	718.87
B	49+08.08	3.21	718.91	718.91
C	49+18.08	3.21	718.94	718.94
☐ Brg. Pier 1	49+29.58	3.21	718.97	718.97
D	49+39.58	3.21	718.99	719.01
E	49+49.58	3.21	719.01	719.04
F	49+59.58	3.21	719.02	719.06
G	49+69.58	3.21	719.03	719.06
H	49+79.58	3.21	719.03	719.05
I	49+89.58	3.21	719.03	719.04
☐ Brg. Pier 2	50+00.00	3.21	719.02	719.02
J	50+10.00	3.21	719.00	719.01
K	50+20.00	3.21	718.98	719.01
L	50+30.00	3.21	718.96	718.99
M	50+40.00	3.21	718.93	718.97
N	50+50.00	3.21	718.90	718.92
O	50+60.00	3.21	718.86	718.87
☐ Brg. Pier 3	50+70.42	3.21	718.81	718.81
P	50+80.42	3.21	718.76	718.76
Q	50+90.42	3.21	718.70	718.70
R	51+00.42	3.21	718.64	718.64
☐ Brg. S. Abut.	51+11.42	3.21	718.57	718.57
Bk. S. Abut.	51+13.75	3.21	718.55	718.55

BEAM 5

Location	Station	Offset	Theoretical Grade Elevations	Theoretical Grade Elevations Adjusted for Dead Load Deflection
Bk. N. Abut.	48+85.75	9.63	718.72	718.72
☐ Brg. N. Abut.	48+88.08	9.63	718.73	718.73
A	48+98.08	9.63	718.77	718.78
B	49+08.08	9.63	718.81	718.81
C	49+18.08	9.63	718.84	718.84
☐ Brg. Pier 1	49+29.58	9.63	718.88	718.88
D	49+39.58	9.63	718.90	718.91
E	49+49.58	9.63	718.92	718.94
F	49+59.58	9.63	718.93	718.96
G	49+69.58	9.63	718.93	718.97
H	49+79.58	9.63	718.93	718.96
I	49+89.58	9.63	718.93	718.94
☐ Brg. Pier 2	50+00.00	9.63	718.92	718.92
J	50+10.00	9.63	718.91	718.92
K	50+20.00	9.63	718.89	718.91
L	50+30.00	9.63	718.86	718.90
M	50+40.00	9.63	718.83	718.87
N	50+50.00	9.63	718.80	718.83
O	50+60.00	9.63	718.76	718.77
☐ Brg. Pier 3	50+70.42	9.63	718.71	718.71
P	50+80.42	9.63	718.66	718.66
Q	50+90.42	9.63	718.61	718.61
R	51+00.42	9.63	718.55	718.55
☐ Brg. S. Abut.	51+11.42	9.63	718.47	718.47
Bk. S. Abut.	51+13.75	9.63	718.46	718.46

BEAM 6

Location	Station	Offset	Theoretical Grade Elevations	Theoretical Grade Elevations Adjusted for Dead Load Deflection
Bk. N. Abut.	48+85.75	16.04	718.60	718.60
☐ Brg. N. Abut.	48+88.08	16.04	718.61	718.61
A	48+98.08	16.04	718.66	718.66
B	49+08.08	16.04	718.70	718.70
C	49+18.08	16.04	718.73	718.73
☐ Brg. Pier 1	49+29.58	16.04	718.76	718.76
D	49+39.58	16.04	718.78	718.79
E	49+49.58	16.04	718.80	718.83
F	49+59.58	16.04	718.81	718.85
G	49+69.58	16.04	718.82	718.85
H	49+79.58	16.04	718.82	718.84
I	49+89.58	16.04	718.81	718.82
☐ Brg. Pier 2	50+00.00	16.04	718.81	718.81
J	50+10.00	16.04	718.79	718.80
K	50+20.00	16.04	718.77	718.79
L	50+30.00	16.04	718.75	718.78
M	50+40.00	16.04	718.72	718.75
N	50+50.00	16.04	718.68	718.71
O	50+60.00	16.04	718.64	718.66
☐ Brg. Pier 3	50+70.42	16.04	718.60	718.60
P	50+80.42	16.04	718.55	718.54
Q	50+90.42	16.04	718.49	718.49
R	51+00.42	16.04	718.43	718.43
☐ Brg. S. Abut.	51+11.42	16.04	718.36	718.36
Bk. S. Abut.	51+13.75	16.04	718.34	718.34

MODEL: Default  
FILE NAME: \\10.0.0.90\Projects\2021\121211C - IL 78 over FAI 74 & CH 184 CADD - DWG\4.4 - Struct\0720032-68D48-008-Top of Slab Elevations.dgn



**TWM, INC.**  
www.twm-inc.com  
IL DESIGN FIRM  
LICENSE NO:  
184-001220

USER NAME = ckd\veitl  
DESIGNED - JBE  
CHECKED - CDK  
PLOT SCALE = 0:2,0000 "/in.  
DRAWN - JBE  
PLOT DATE = 9/22/2023  
CHECKED - CDK  
REVISED -

DESIGNED - JBE  
CHECKED - CDK  
DRAWN - JBE  
CHECKED - CDK  
REVISED -

REVISED -  
REVISED -  
REVISED -  
REVISED -

STATE OF ILLINOIS  
DEPARTMENT OF TRANSPORTATION

TOP OF SLAB ELEVATIONS  
STRUCTURE NO. 072-0032

SHEET 8 OF 25 SHEETS

F.A.I. RTE.	SECTION	COUNTY	TOTAL SHEETS	SHEET NO.
74	[(72-30;48-29)HB-1]BRR	PEORIA	115	37
			CONTRACT NO. 68D48	
		ILLINOIS FED. AID PROJECT		

EAST EDGE OF SHOULDER

Location	Station	Offset	Theoretical Grade Elevations
N. End of N. Approach	48+56.75	-16.00	718.45
A1	48+66.75	-16.00	718.51
A2	48+76.75	-16.00	718.56
S. End of N. Approach	48+86.75	-16.00	718.61

EAST EDGE OF PAVEMENT

Location	Station	Offset	Theoretical Grade Elevations
N. End of N. Approach	48+56.75	-12.00	718.53
A1	48+66.75	-12.00	718.59
A2	48+76.75	-12.00	718.64
S. End of N. Approach	48+86.75	-12.00	718.69

CL ROADWAY, P.G. & STAGE CONST. JT.

Location	Station	Offset	Theoretical Grade Elevations
N. End of N. Approach	48+56.75	0.00	718.71
A1	48+66.75	0.00	718.77
A2	48+76.75	0.00	718.82
S. End of N. Approach	48+86.75	0.00	718.87

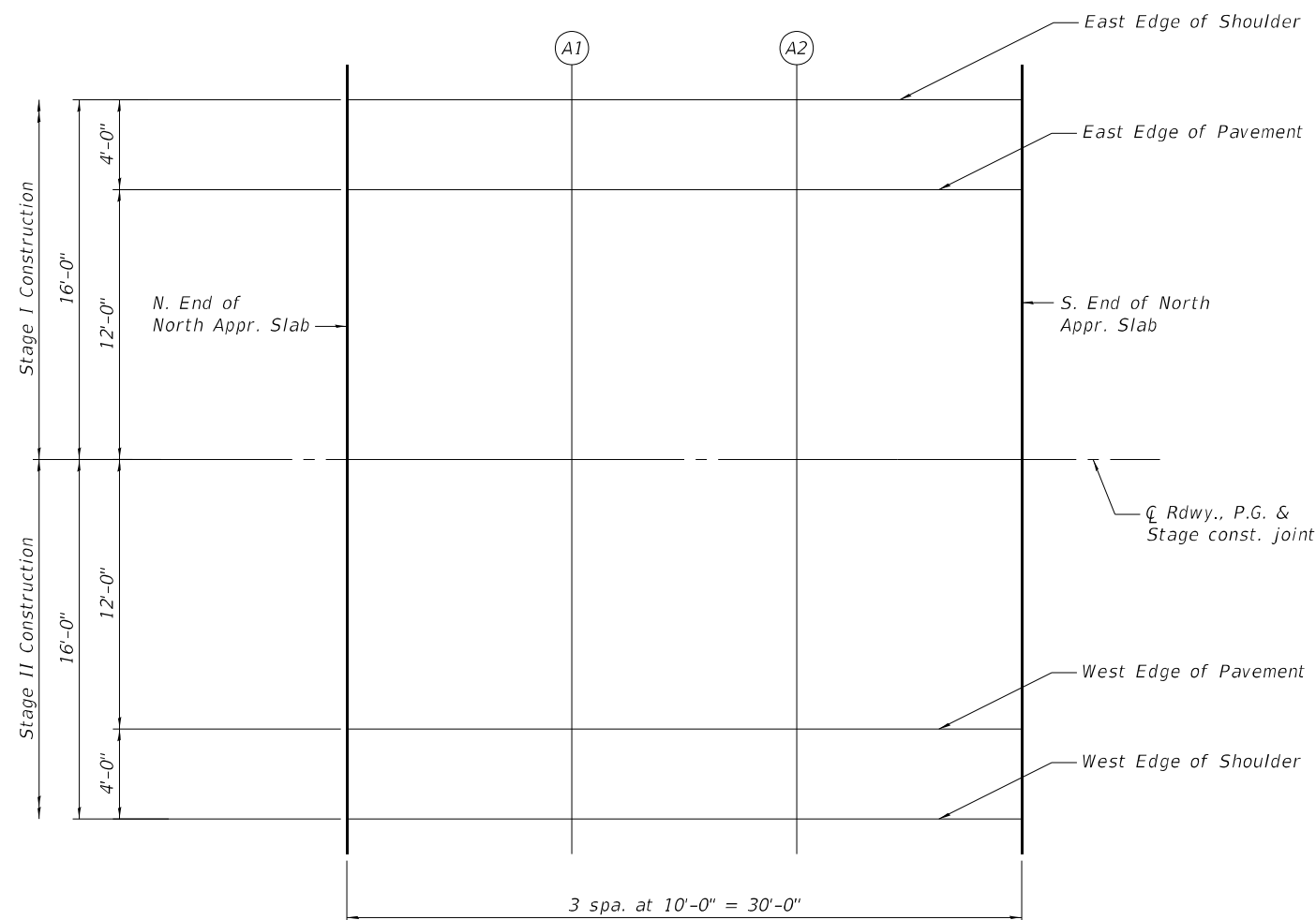
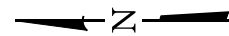

PLAN  
(North Approach)

WEST EDGE OF PAVEMENT

Location	Station	Offset	Theoretical Grade Elevations
N. End of N. Approach	48+56.75	12.00	718.53
A1	48+66.75	12.00	718.59
A2	48+76.75	12.00	718.64
S. End of N. Approach	48+86.75	12.00	718.69

WEST EDGE OF SHOULDER

Location	Station	Offset	Theoretical Grade Elevations
N. End of N. Approach	48+56.75	16.00	718.45
A1	48+66.75	16.00	718.51
A2	48+76.75	16.00	718.56
S. End of N. Approach	48+86.75	16.00	718.61

MODEL: Default  
FILE NAME: \\110.0.0.90\Projects\2021\112211C - IL 78 over FAI 74 & CH 184 CADD - DWG\4.4 - Struct\0720032-68D48-009-Top of North Approach Slab Elevations.dgn



USER NAME =	ckotveit	DESIGNED -	JBE	REVISED -	
		CHECKED -	CDK	REVISED -	
PLOT SCALE =	0:2,0000 " / in.	DRAWN -	JBE	REVISED -	
PLOT DATE =	9/22/2023	CHECKED -	CDK	REVISED -	

STATE OF ILLINOIS  
DEPARTMENT OF TRANSPORTATION

TOP OF NORTH APPROACH SLAB ELEVATIONS  
STRUCTURE NO. 072-0032

SHEET 9 OF 25 SHEETS

F.A.I. RTE.	SECTION	COUNTY	TOTAL SHEETS	SHEET NO.
74	[(72-30;48-29)HB-1]BRR	PEORIA	115	38
			CONTRACT NO. 68D48	
		ILLINOIS FED. AID PROJECT		

EAST EDGE OF SHOULDER

Location	Station	Offset	Theoretical Grade Elevations
N. End of S. Approach	51+12.75	-16.00	718.35
A3	51+22.75	-16.00	718.28
A4	51+32.75	-16.00	718.20
S. End of S. Approach	51+42.75	-16.00	718.12

EAST EDGE OF PAVEMENT

Location	Station	Offset	Theoretical Grade Elevations
N. End of S. Approach	51+12.75	-12.00	718.43
A3	51+22.75	-12.00	718.36
A4	51+32.75	-12.00	718.28
S. End of S. Approach	51+42.75	-12.00	718.20

℄ ROADWAY, P.G. & STAGE CONST. JT.

Location	Station	Offset	Theoretical Grade Elevations
N. End of S. Approach	51+12.75	0.00	718.61
A3	51+22.75	0.00	718.54
A4	51+32.75	0.00	718.46
S. End of S. Approach	51+42.75	0.00	718.38

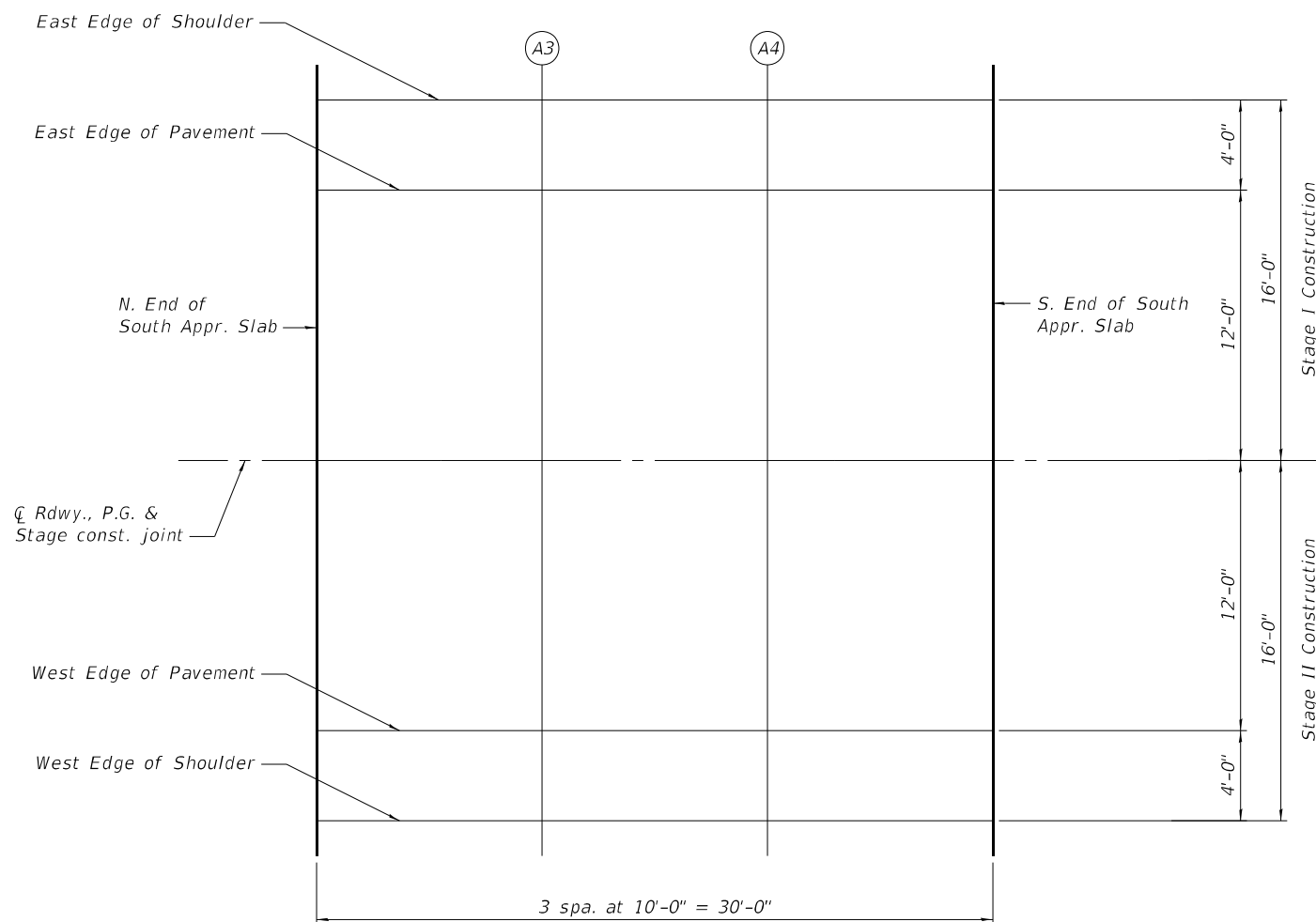
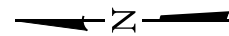

PLAN  
(South Approach)

WEST EDGE OF PAVEMENT

Location	Station	Offset	Theoretical Grade Elevations
N. End of S. Approach	51+12.75	12.00	718.43
A3	51+22.75	12.00	718.36
A4	51+32.75	12.00	718.28
S. End of S. Approach	51+42.75	12.00	718.20

WEST EDGE OF SHOULDER

Location	Station	Offset	Theoretical Grade Elevations
N. End of S. Approach	51+12.75	16.00	718.35
A3	51+22.75	16.00	718.28
A4	51+32.75	16.00	718.20
S. End of S. Approach	51+42.75	16.00	718.12

MODEL: Default  
FILE NAME: \\110.0.0.90\Projects\2021\112211C - IL 78 over FAI 74 & CH 184 CADD - DWG\4.4 - Struct\0720032-68D48-010-Top of South Approach Slab Elevations.dgn



**TWM, INC.**  
www.twm-inc.com  
IL DESIGN FIRM  
LICENSE NO:  
184-001220

USER NAME = cktovell  
DESIGNED - JBE  
CHECKED - CDK  
PLOT SCALE = 0:2,0000 "/ in.  
DRAWN - JBE  
PLOT DATE = 9/22/2023  
CHECKED - CDK

REVISIED -  
REVISIED -  
REVISIED -  
REVISIED -

STATE OF ILLINOIS  
DEPARTMENT OF TRANSPORTATION

TOP OF SOUTH APPROACH SLAB ELEVATIONS  
STRUCTURE NO. 072-0032

SHEET 10 OF 25 SHEETS

F.A.I. RTE.	SECTION	COUNTY	TOTAL SHEETS	SHEET NO.
74	[(72-30;48-29)HB-1]BRR	PEORIA	115	39
CONTRACT NO. 68D48				
ILLINOIS FED. AID PROJECT				

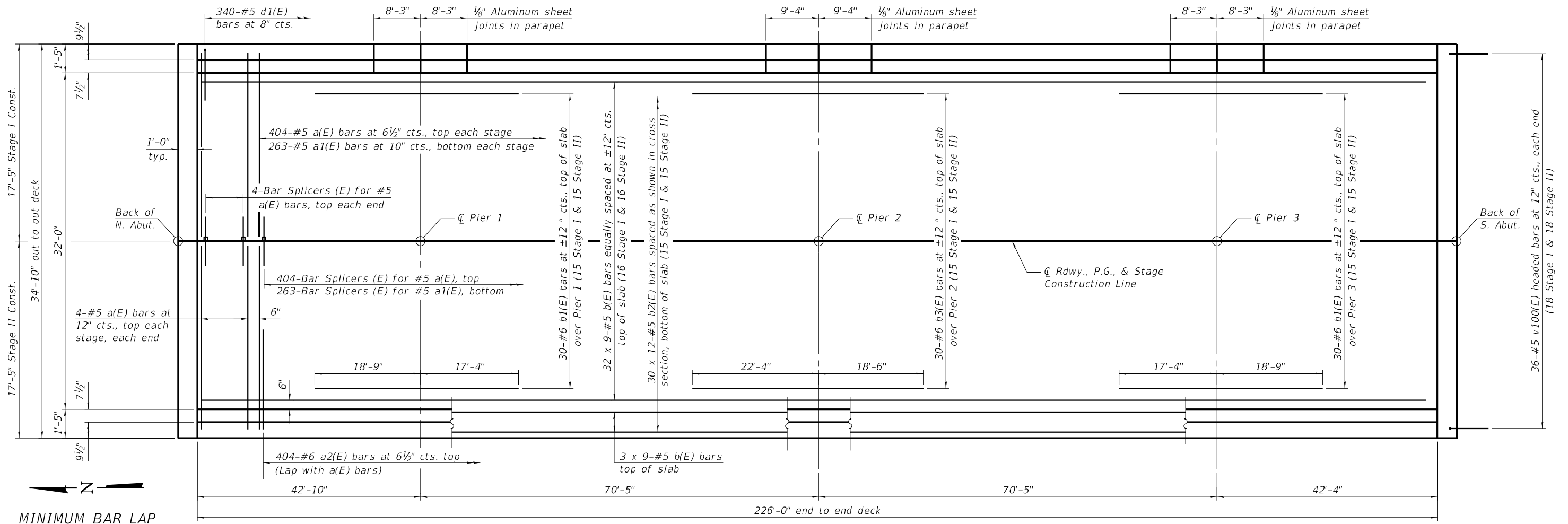

**MINIMUM BAR LAP**  
#5 bar = 3'-6"

**PLAN**

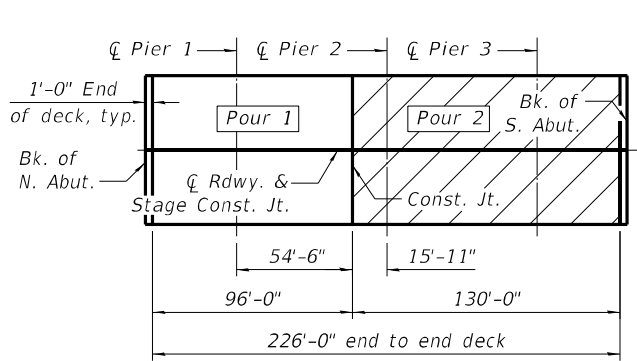

**DECK POURING SEQUENCE**

**Notes:**  
See Sheet 12 of 25 for superstructure details and Bill of Material.  
Bars indicated thus 20 x 3-#5 etc. indicates 20 lines of bars with 3 lengths per line.  
When the deck pour is stopped for the day at one or more of the transverse bonded construction joints in the deck pouring sequence as shown, the next pour shall not be made until both of the following are met:  
1. At least 72 hours shall have elapsed from the end of the previous pour.  
2. The concrete strength shall have attained a minimum flexureal strength of 675 psi or a minimum compressive strength of 4000 psi.

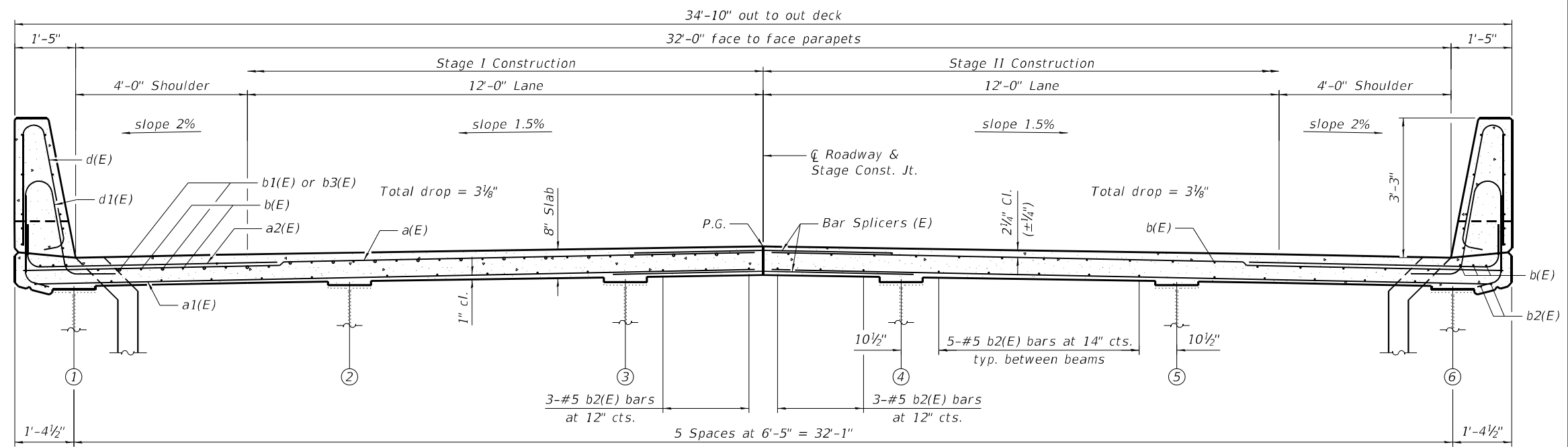

**CROSS SECTION**  
(Looking South)

**STATE OF ILLINOIS**  
**DEPARTMENT OF TRANSPORTATION**

**SUPERSTRUCTURE**  
**STRUCTURE NO. 072-0032**

F.A.I. RTE.	SECTION	COUNTY	TOTAL SHEETS	SHEET NO.
74	[(72-30;48-29)HB-1]BRR	PEORIA	115	40
CONTRACT NO. 68D48				

MODEL: Default  
FILE NAME: P:\2021\1122\11C - IL 78 over FAI 74 & CH 184 CADD - DWG\4.4 - Struct\0720032-68D48-01-1-Superstructure.dgn



**TWM, INC.**  
www.twm-inc.com  
ILL. DESIGN FIRM LICENSE NO: 184-001220

USER NAME =	ckotveit	DESIGNED -	JBE	REVISED -	
CHECKED -	CDK	RECHECKED -		REVISED -	
PLOT SCALE =	0:2.0000 "/>				



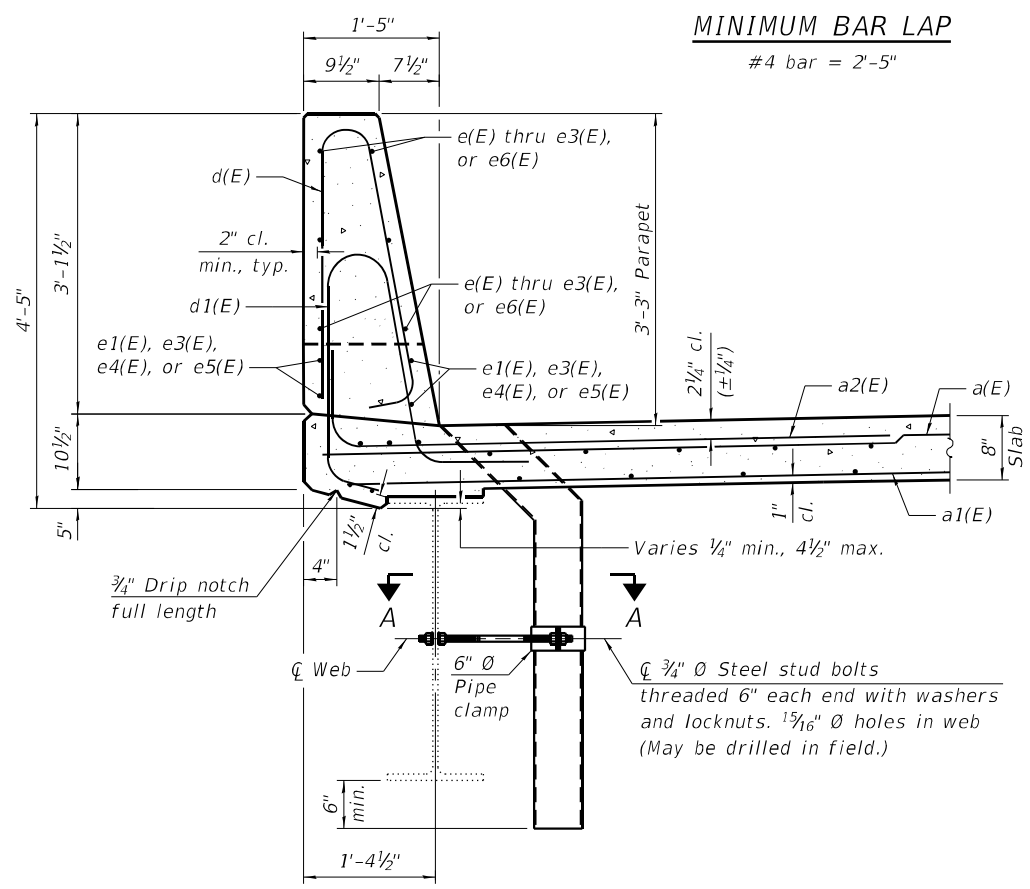
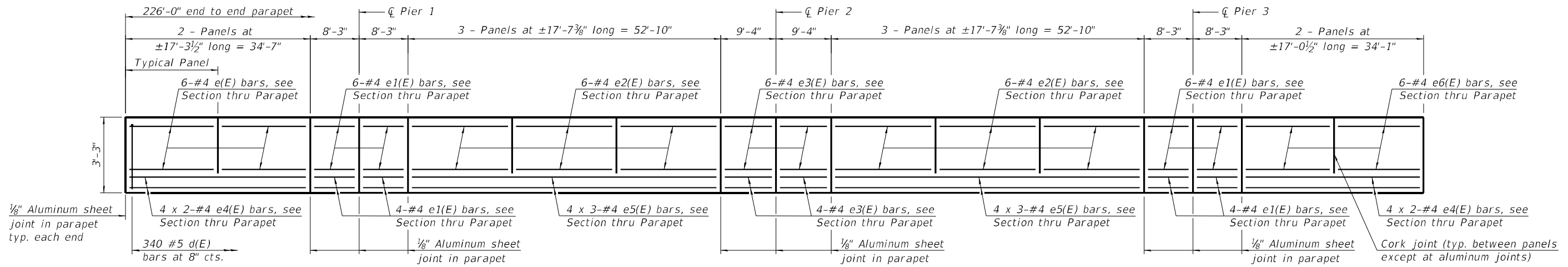

SECTION THRU PARAPET

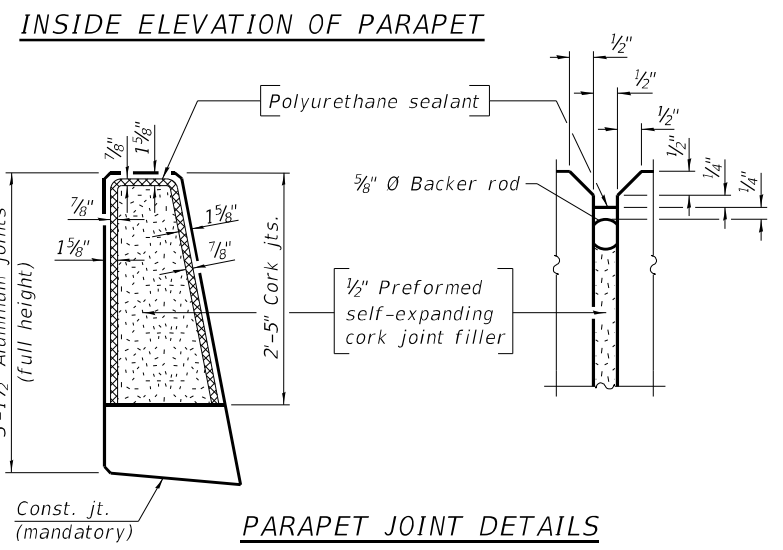

PARAPET JOINT DETAILS

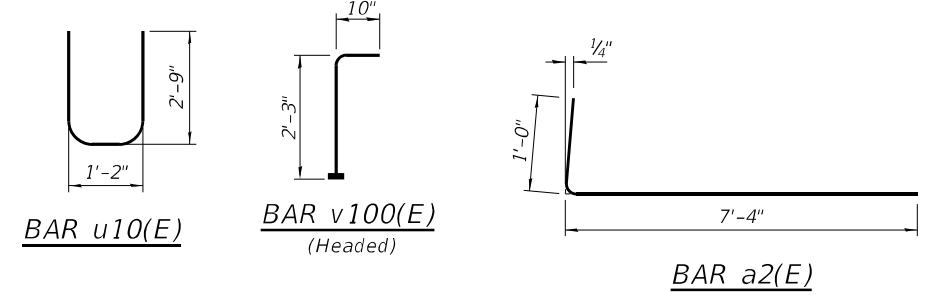

SUPERSTRUCTURE BILL OF MATERIAL

Bar	No.	Size	Length	Shape
a(E)	824	#5	17'-1"	—
a1(E)	526	#5	16'-5"	—
a2(E)	808	#6	8'-4"	—
b(E)	342	#5	28'-3"	—
b1(E)	60	#6	36'-1"	—
b2(E)	360	#5	22'-1"	—
b3(E)	30	#6	40'-10"	—
d(E)	680	#5	6'-5"	—
d1(E)	680	#5	6'-9"	—
e(E)	24	#4	17'-0"	—
e1(E)	80	#4	7'-11"	—
e2(E)	72	#4	17'-3"	—
e3(E)	40	#4	9'-0"	—
e4(E)	32	#4	18'-4"	—
e5(E)	48	#4	19'-2"	—
e6(E)	24	#4	16'-9"	—
m10(E)	20	#6	17'-1"	—
m11(E)	32	#6	6'-0"	—
m12(E)	16	#6	1'-0"	—
m13(E)	8	#4	17'-1"	—
s10(E)	64	#5	6'-10"	—
s11(E)	64	#5	9'-10"	—
u10(E)	64	#4	6'-8"	—
v100(E)	72	#5	3'-1"	—
Reinforcement Bars, Epoxy Coated		Lbs.		72,190
Concrete Superstructure		Cu. Yds.		306.7

Notes:  
 Fiberglass pipe shall conform to ASTM D2996, with short-time rupture strength hoop tensile stress of 30,000 p.s.i. minimum.  
 The exterior surfaces of the floor drains shall be painted according to Article 506 with the finish coat as specified. The exterior surfaces of the drains shall be cleaned according to the Society of Protective Coating's Spec. SSPC-SP1 prior to painting.  
 The top portion of aluminum floor drains shall be coated to minimize reaction with wet concrete. The clamping device shall be galvanized according to AASHTO M 232. Cost of clamping device included with Floor Drains.  
 The 1/8" aluminum sheet shall be ASTM B 209 alloy 3003-H14 and coated to minimize reaction with wet concrete. Cost included with Concrete Superstructure.  
 The polyurethane sealant shall be according to Article 1050.04 of the Std. Spec. and the color shall be gray.  
 Headed bars shall conform to ASTM A970 with threaded attachment; Class HA; and reinforcement bars conforming to ASTM A706. Cost included with Reinforcement Bars, Epoxy Coated.

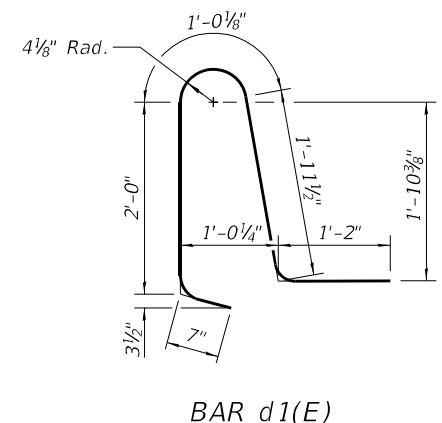
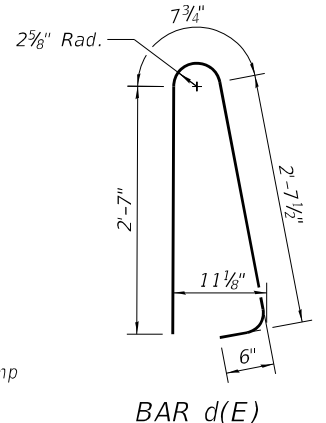
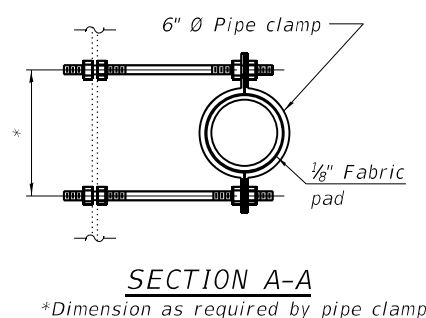
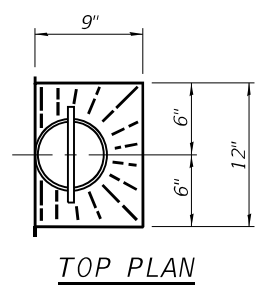
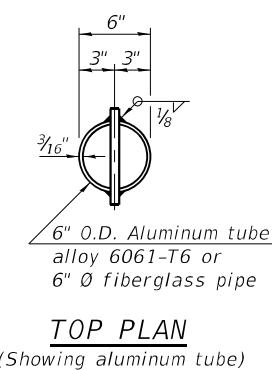
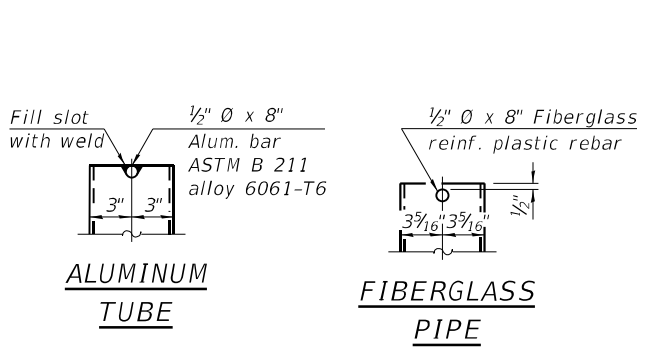

Bars indicated thus 1 x 2-#4 etc. indicates 1 line of bars with 2 lengths per line.

MODEL: Default FILE NAME: I:\10.0.0.90\Projects\2021\12\11\21\1211C - IL 78 over FAI 74 & CH 184 CADD - DWG\4.4 - Struct\0720032-68D48-012-Superstructure Details.dgn



TWM, INC.  
 www.twm-inc.com  
 IL DESIGN FIRM LICENSE NO: 184-001220

USER NAME =	ckotveit	DESIGNED -	JBE	REVISED -	
CHECKED -	CDK	CHECKED -	CDK	REVISED -	
PLOT SCALE =	0:2,0000 "/in.	DRAWN -	JBE	REVISED -	
PLOT DATE =	9/22/2023	CHECKED -	CDK	REVISED -	

STATE OF ILLINOIS DEPARTMENT OF TRANSPORTATION

SUPERSTRUCTURE DETAILS STRUCTURE NO. 072-0032

SHEET 12 OF 25 SHEETS

F.A.I. RTE.	SECTION	COUNTY	TOTAL SHEETS	SHEET NO.
74	[(72-30;48-29)HB-1]BRR	PEORIA	115	41
CONTRACT NO. 68D48				
ILLINOIS / FED. AD PROJECT				

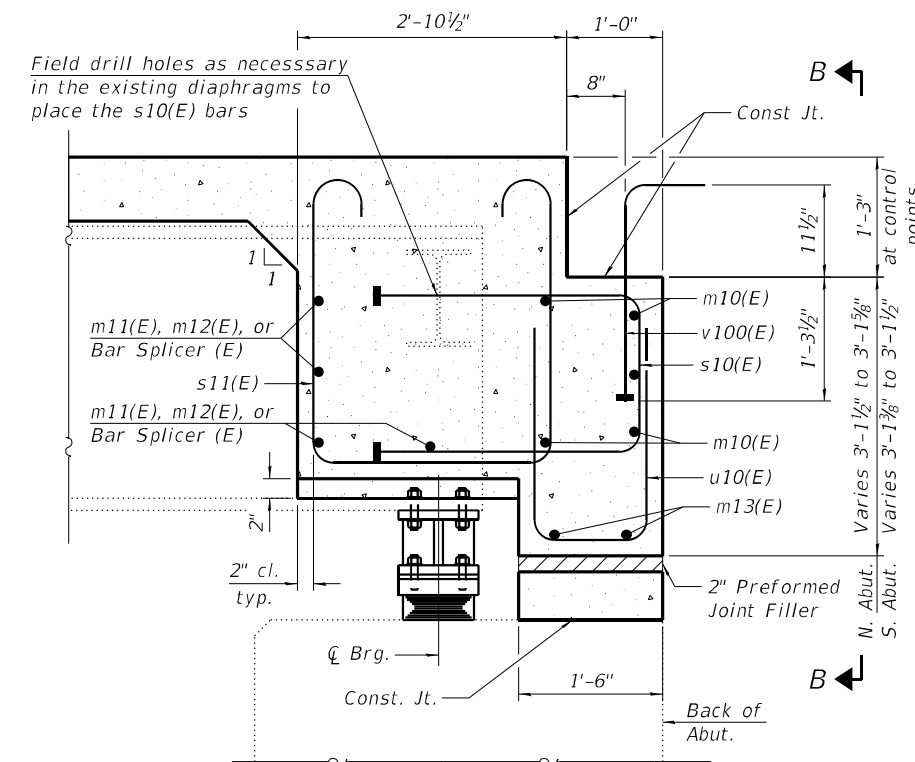
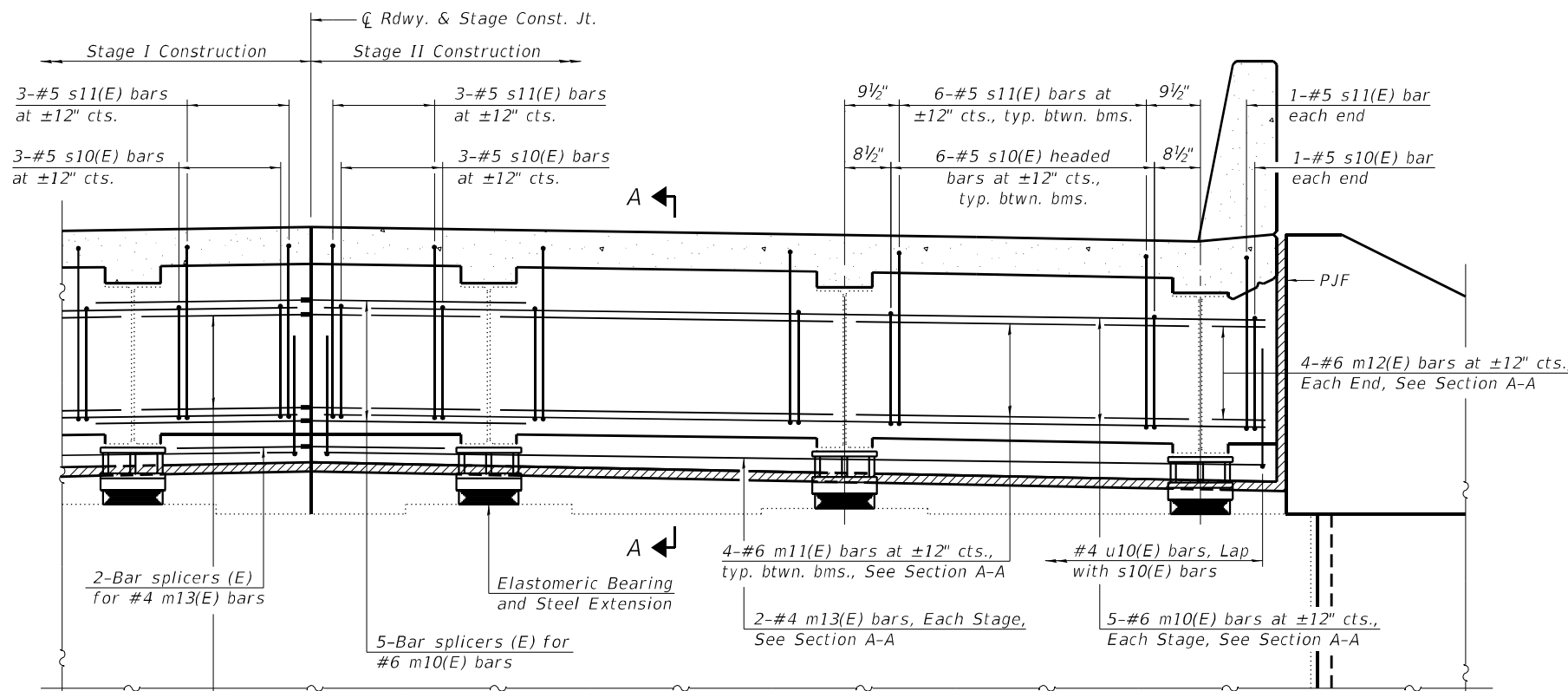

3-#6 Bar Splicers (E) in front face of diaphragm  
 1-#6 Bar Splicer (E) below existing steel diaphragms  
 See Sheet 25 of 25 for Diaphragm Bar Splicer Detail

**DIAPHRAGM AT ABUTMENT**

(South abutment looking South shown,  
 North Abutment looking North similar by mirror image)

1/2" Ø Stainless steel expansion bolts with nuts and washers at 12" cts. according to Article 1006.29(d) of the Standard Specifications

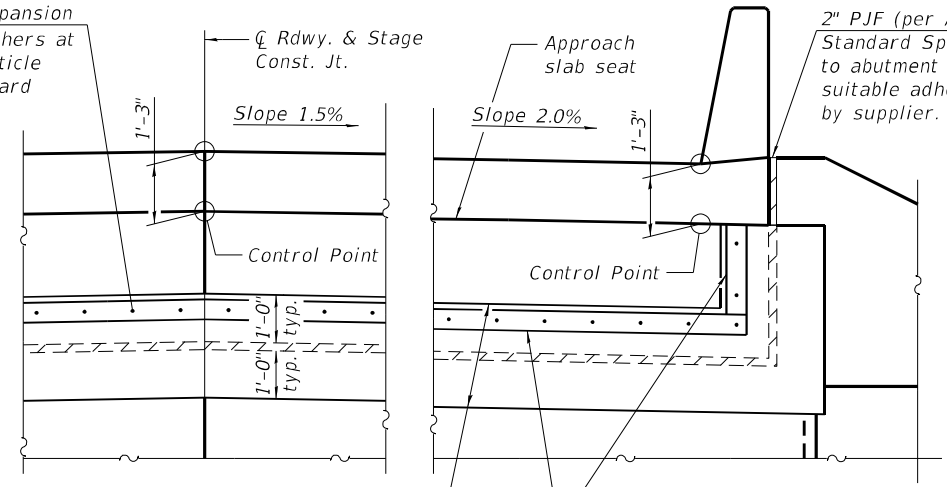

Limits of fabric reinforced elastomeric mat according to Section 1028 of the Standard Specifications and installed according to applicable requirements of Article 520.09 of the Standard Specifications.

2" PJP (per Article 1051.09 of the Standard Specifications) bonded to abutment cap and wingwall with suitable adhesive as recommended by supplier.

3/8" x 5" Galvanized plate according to Article 509.05 of the Standard Specifications

**VIEW B-B**

(Showing 2" PJP and limits of Fabric Reinforced Elastomeric Mat)

**Notes:**

- See sheet 12 of 25 for superstructure details and Bill of Material
- The approach slab seat shall have a constant slope determined from the control points shown.
- See sheet 18 of 25 for bearing details.
- See sheet 25 of 25 for bar splicer details.
- Cost of fabric reinforced elastomeric mat, galvanized plate, stainless steel expansion bolts with nuts and washers and installation are included in the cost of Concrete Superstructure.

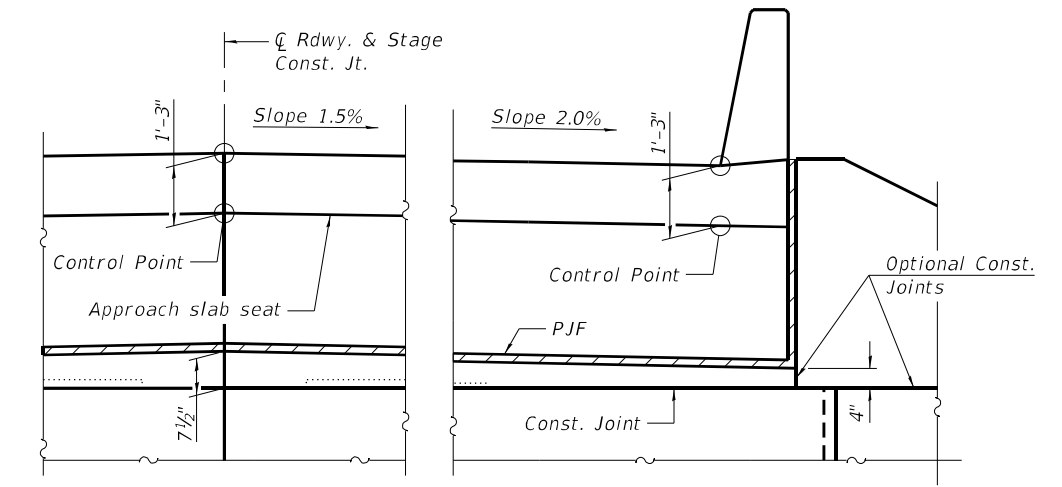

**VIEW B-B**

MODEL: Default  
 FILE NAME: I:\10.0.0.90\Projects\2021\121221\1C - IL 78 over FAI 74 & CH 18\4 CADD - DWG\4.4 - Struct\0720032-68D48-013-Diaphragm Details.dgn



USER NAME =	ckotveit	DESIGNED -	JBE	REVISED -	
PLOT SCALE =	0:2,0000 "/in.	CHECKED -	CDK	REVISED -	
PLOT DATE =	9/22/2023	DRAWN -	JBE	REVISED -	
		CHECKED -	CDK	REVISED -	

**STATE OF ILLINOIS  
 DEPARTMENT OF TRANSPORTATION**

**DIAPHRAGM DETAILS  
 STRUCTURE NO. 072-0032**

SHEET 13 OF 25 SHEETS

F.A.I. RTE.	SECTION	COUNTY	TOTAL SHEETS	SHEET NO.
74	[(72-30;48-29)HB-1]BRR	PEORIA	115	42
CONTRACT NO. 68D48				

ILLINOIS FED. AID PROJECT

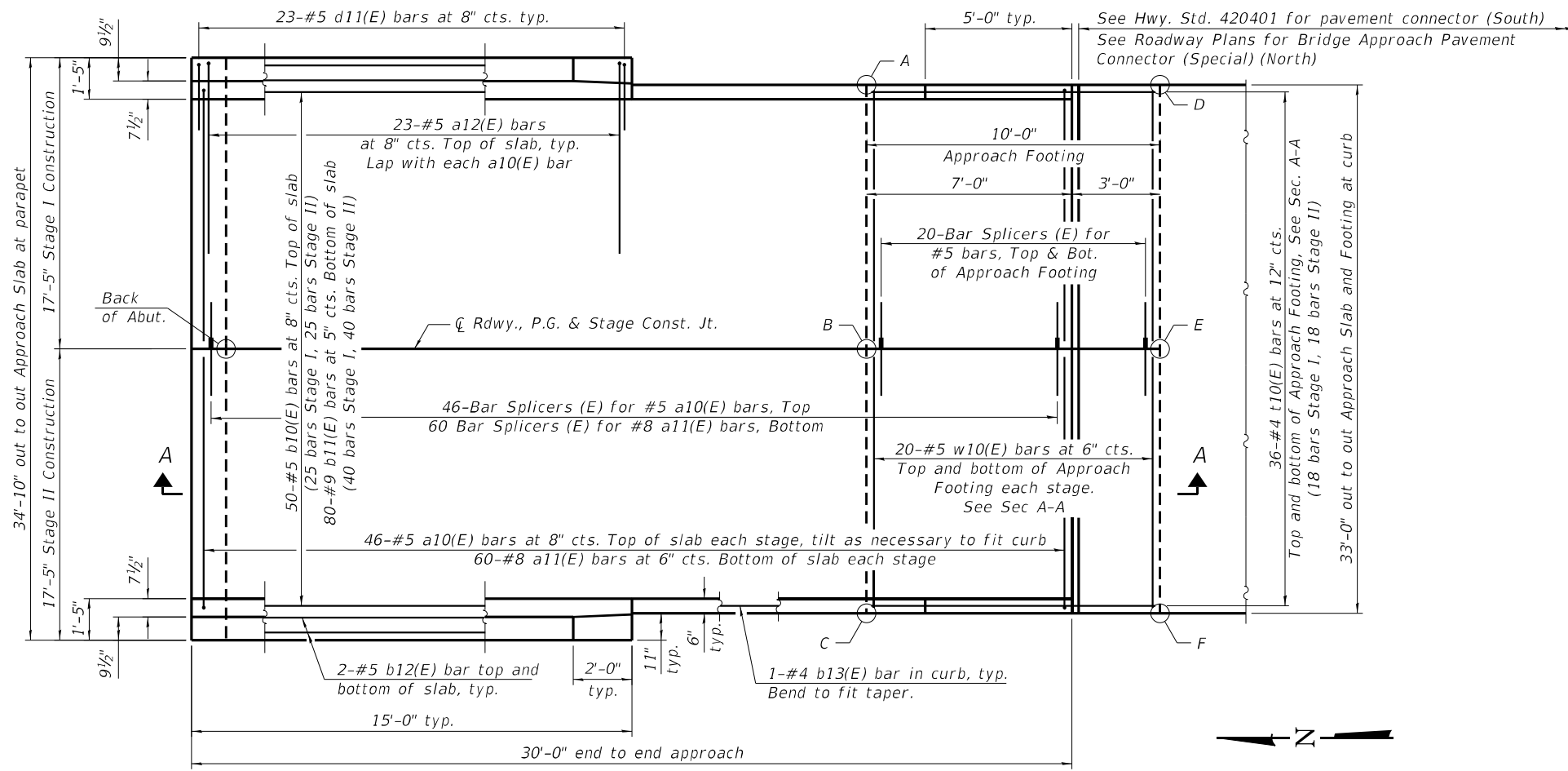

**PLAN**

(South approach slab shown; north approach slab similar by mirror image)

**TOP AND BOTTOM ELEVATIONS FOR APPROACH FOOTING**

North Approach			South Approach		
Point/Location	Top	Bottom	Point/Location	Top	Bottom
A - SE	717.24	716.40	A - NE	716.92	716.09
B - S	717.50	716.66	B - N	717.18	716.35
C - SW	717.24	716.40	C - NW	716.92	716.09
D - NE	717.18	716.34	D - SE	716.84	716.01
E - N	717.44	716.60	E - S	717.10	716.27
F - NW	717.18	716.34	F - SW	716.84	716.01

Notes:  
For Section A-A and Bill of Material, see sheet 15 of 25.

MODEL: Default  
FILE NAME: I:\10.0.0.90\Projects\2021\12\112211C - IL 78 over FAI 74 & CH 184 CADD - DWG\4.4-Struct\0720032-68D48-014-Bridge Approach Slab Details.dgn

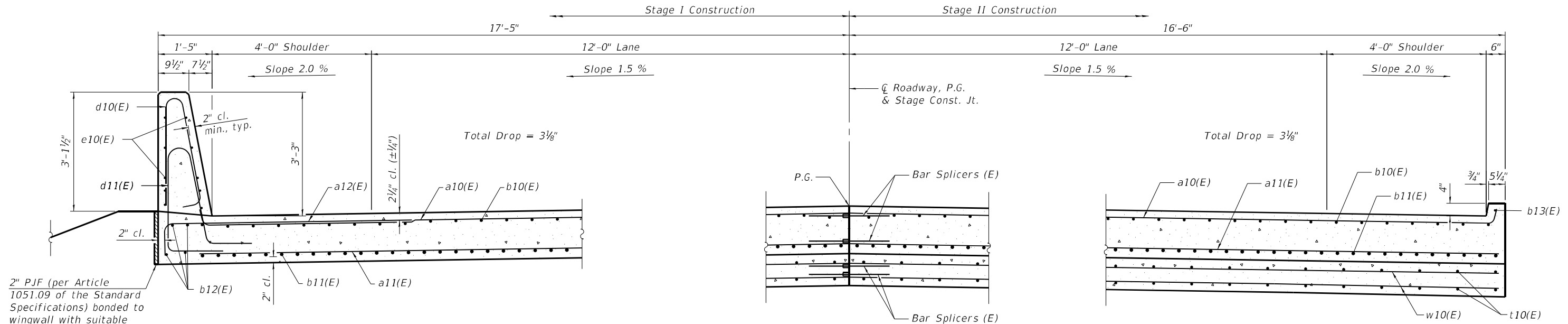

**NEAR ABUTMENT**

**CROSS SECTION (Looking South)**

**AT APPROACH FOOTING**



USER NAME =	ckotveit	DESIGNED -	JBE	REVISED -	
PLOT SCALE =	0:2,0000 "/> <td>CHECKED -</td> <td>CDK</td> <td>REVISED -</td> <td></td>	CHECKED -	CDK	REVISED -	
PLOT DATE =	9/22/2023	DRAWN -	JBE	REVISED -	
		CHECKED -	CDK	REVISED -	

**STATE OF ILLINOIS  
DEPARTMENT OF TRANSPORTATION**

**BRIDGE APPROACH SLAB DETAILS  
STRUCTURE NO. 072-0032**

SHEET 14 OF 25 SHEETS

F.A.I. RTE.	SECTION	COUNTY	TOTAL SHEETS	SHEET NO.
74	[(72-30;48-29)HB-1]BRR	PEORIA	115	43
			CONTRACT NO. 68D48	
ILLINOIS FED. AID PROJECT				

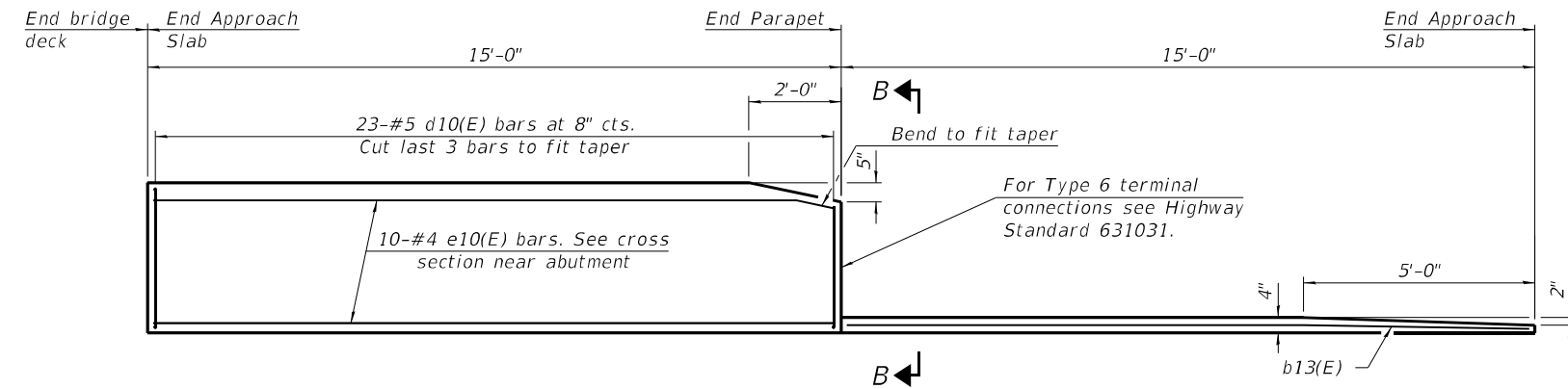

INSIDE ELEVATION OF PARAPET AND CURB AT SOUTH APPROACH SLAB

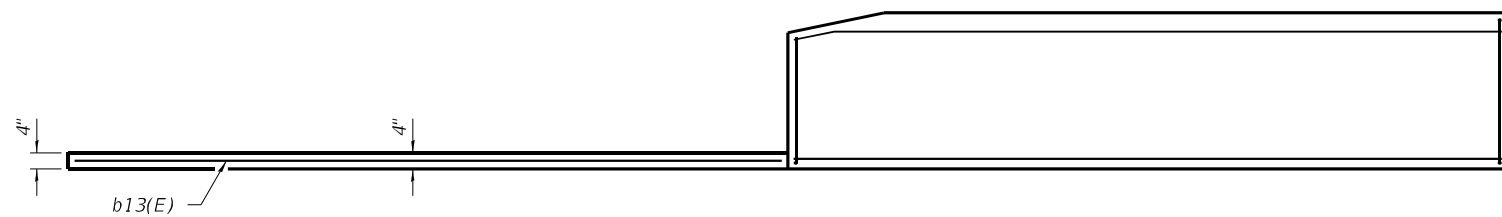

INSIDE ELEVATION OF PARAPET AND CURB AT NORTH APPROACH SLAB

(See Inside Elevation of Parapet and Curb at South Approach Slab for details not shown)

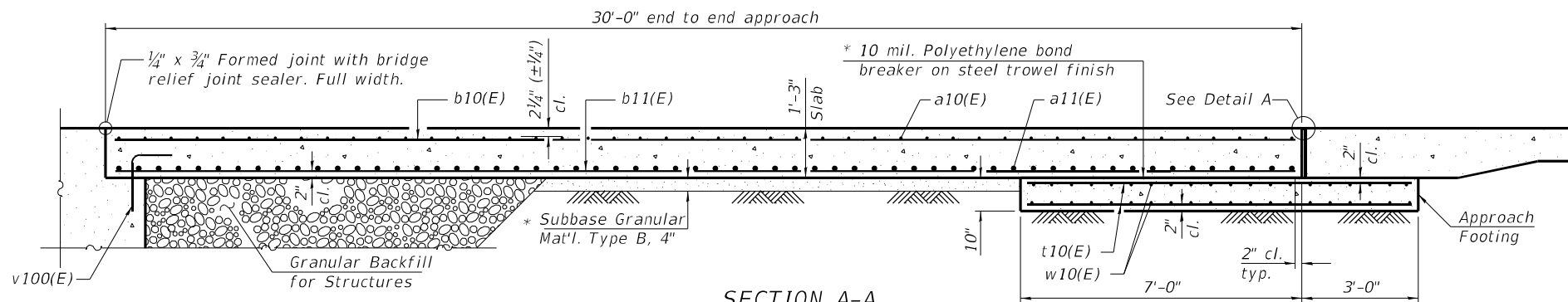

SECTION A-A

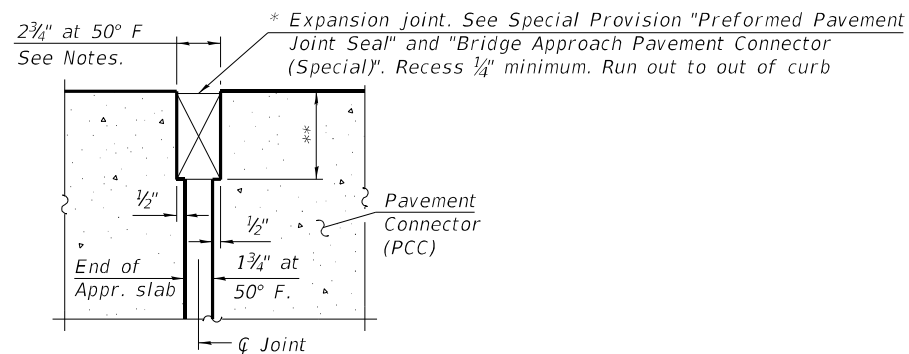

DETAIL A

\* Cost included with Concrete Superstructure (Approach Slab).

\*\* Per manufacturer recommendations

Notes:

The joint opening shall be adjusted for temperature per Article 520.04 of the Standard Specifications. However, since this detail is for jointless structures, the length of bridge used to calculate the adjustment shall be equal to half the total bridge length plus the length of the bridge approach slab.  
Parapet concrete shall be paid for as Concrete Superstructure.  
Approach slab shall be paid for as Concrete Superstructure (Approach Slab).  
Approach footing concrete shall be paid for as Concrete Structures.  
The approach footing maximum applied service bearing pressure (Qmax) = 2.0 ksf.  
Cost of excavation for approach footing included with Concrete Structures.  
For Granular Backfill for Structures and drainage treatment details, see sheet 2 of 25.

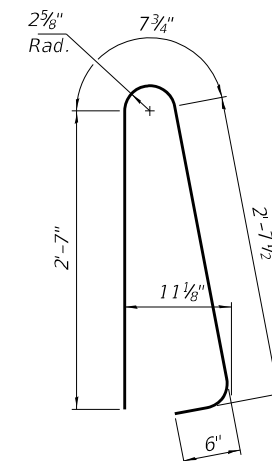

BAR d10(E)

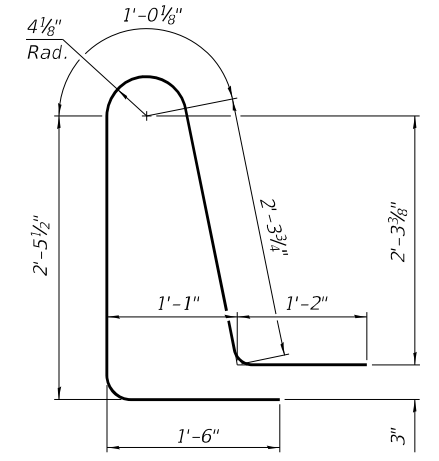

BAR d11(E)

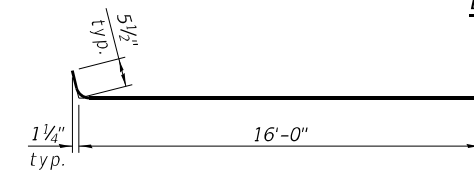

BAR a10(E)

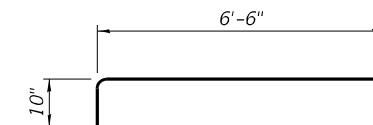

BAR a12(E)

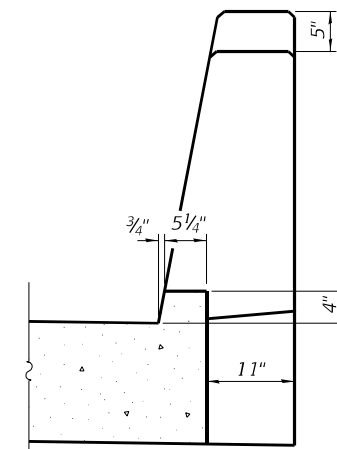

VIEW B-B

TWO APPROACHES  
BILL OF MATERIAL

Bar	No.	Size	Length	Shape	
a10(E)	184	#5	16'-6"	—	
a11(E)	240	#8	16'-2"	—	
a12(E)	92	#5	7'-4"	—	
b10(E)	100	#5	29'-8"	—	
b11(E)	160	#9	29'-8"	—	
b12(E)	16	#5	14'-8"	—	
b13(E)	4	#4	14'-8"	—	
d10(E)	92	#5	6'-5"	⤴	
d11(E)	92	#5	8'-6"	⤴	
e10(E)	40	#4	14'-8"	—	
t10(E)	144	#4	9'-8"	—	
w10(E)	160	#5	16'-2"	—	
Concrete Superstructure				Cu. Yd.	7.8
Concrete Superstructure (Approach Slab)				Cu. Yd.	94.6
Concrete Structures				Cu. Yd.	20.4
Reinforcement Bars, Epoxy Coated				Pound	39,200

MODEL: Default  
FILE NAME: I:\10.0.0.90\Projects\2021\12\11221\1C - IL 78 over FAI 74 & CH 184 CADD - DWG\4.4 - Struct\0720032-68D48-015-Bridge Approach Slab Details.dgn



TWM, INC.  
WWW.TWM-INC.COM  
IL DESIGN FIRM  
LICENSE NO:  
184-001220

USER NAME =	ckotveit	DESIGNED -	JBE	REVISED -	
CHECKED -	CDK	REVISIONS -			
PLOT SCALE =	0:2,0000 "/in.	DRAWN -	JBE	REVISED -	
PLOT DATE =	9/22/2023	CHECKED -	CDK	REVISED -	

STATE OF ILLINOIS  
DEPARTMENT OF TRANSPORTATION

BRIDGE APPROACH SLAB DETAILS  
STRUCTURE NO. 072-0032

SHEET 15 OF 25 SHEETS

F.A.I. RTE.	SECTION	COUNTY	TOTAL SHEETS	SHEET NO.
74	[(72-30;48-29)HB-1]BRR	PEORIA	115	44
CONTRACT NO. 68D48				
ILLINOIS FED. AID PROJECT				

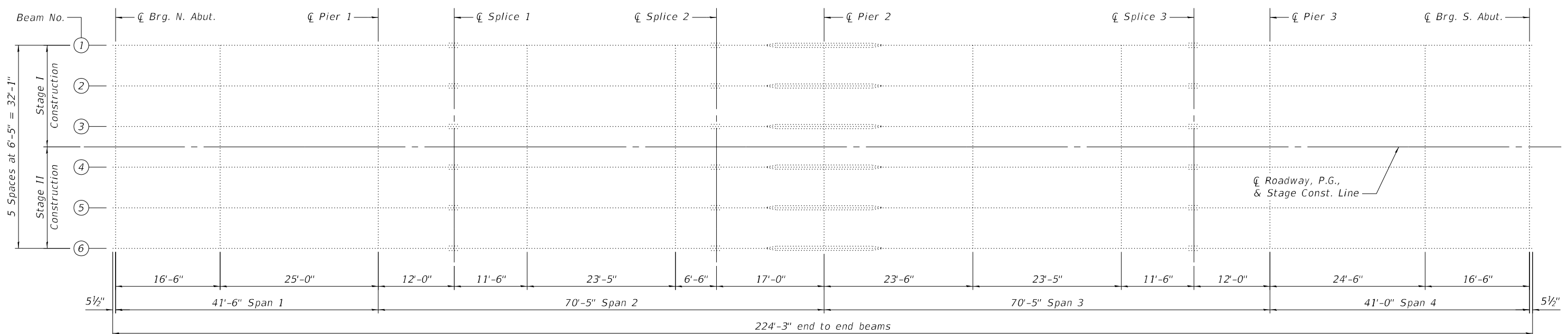
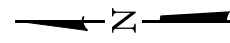

**FRAMING PLAN**

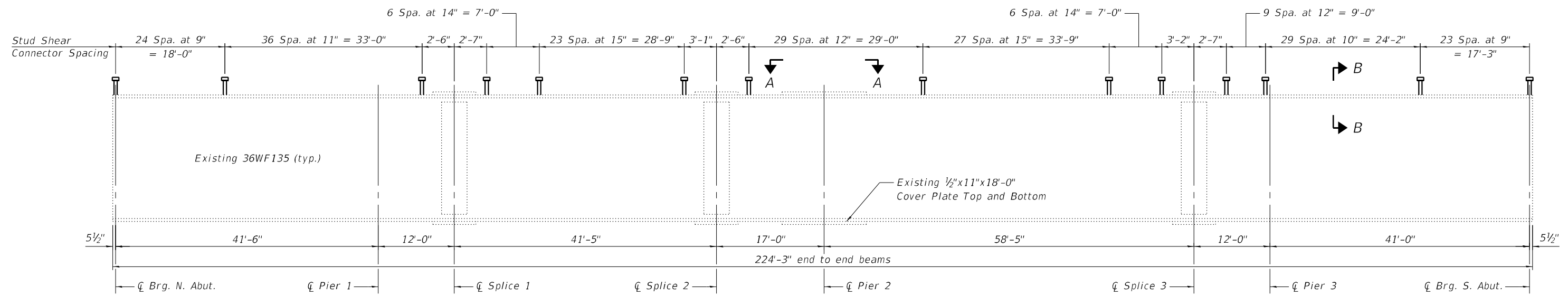

**BEAM ELEVATION**

Note:  
See sheet 17 of 25 for View A-A, Section B-B,  
and additional details.

MODEL: Default  
FILE NAME: I:\10.0.0.90\Projects\2021\121211C - IL 78 over FAI 74 & CH 184 CADD - DWG\4.4 - Struct\0720032-68D48-016-Structural\_Steel.dgn



USER NAME =	ckotveit	DESIGNED -	JBE	REVISED -	
CHECKED -	CDK	REVISOR -		REVISION -	
PLOT SCALE =	0:2.0000 "/ in.	DRAWN -	JBE	REVISOR -	
PLOT DATE =	9/22/2023	CHECKED -	CDK	REVISION -	

**STATE OF ILLINOIS  
DEPARTMENT OF TRANSPORTATION**

**STRUCTURAL STEEL  
STRUCTURE NO. 072-0032**

SHEET 16 OF 25 SHEETS

F.A.I. RTE.	SECTION	COUNTY	TOTAL SHEETS	SHEET NO.
74	[(72-30;48-29)HB-1]BRR	PEORIA	115	45
CONTRACT NO. 68D48				

ILLINOIS FED. AID PROJECT

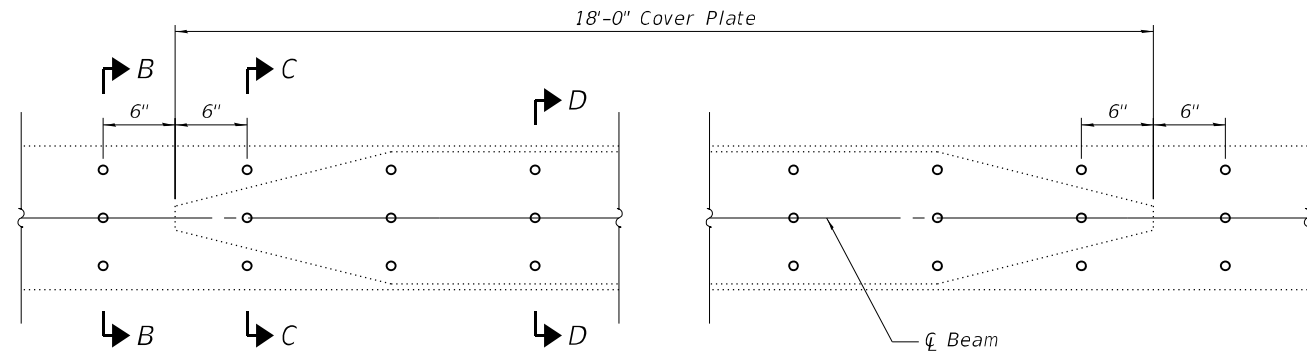

VIEW A-A

(See sheet 16 of 25 for Stud Shear Connector Spacing)

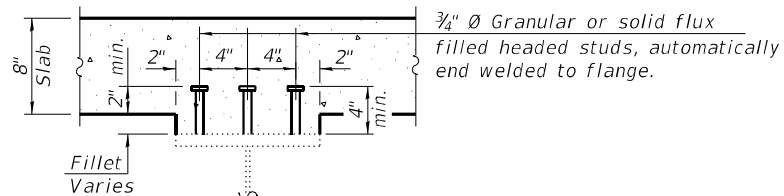

SECTION B-B

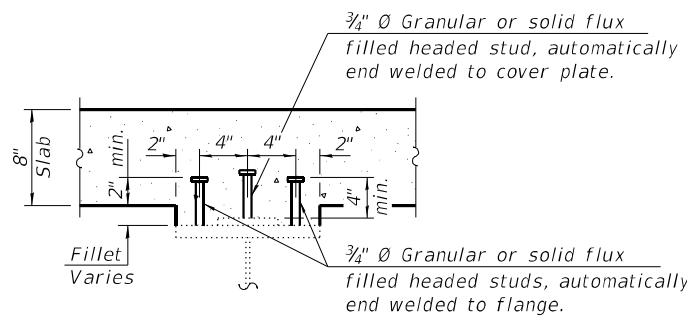

SECTION C-C

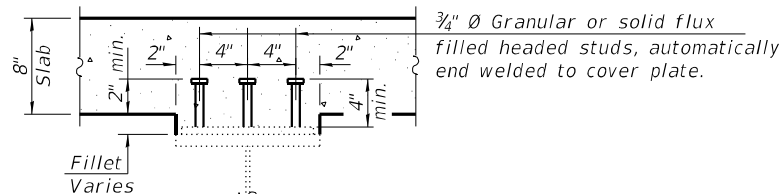

SECTION D-D

Note:  
Total number of 3/4" Ø Granular or solid flux filled headed studs = 3888 (300 welded to cover plates, 3588 welded to flanges)

- $I_s, S_s$ : Non-composite moment of inertia and section modulus of the steel section used for computing  $f_s$ (Total and Overload) due to non-composite dead loads ( $in.^4$  and  $in.^3$ ).
- $I_c(n), S_c(n)$ : Composite moment of inertia and section modulus of the steel and deck based upon the modular ratio, "n", used for computing  $f_s$ (Total and Overload) due to short-term composite live loads ( $in.^4$  and  $in.^3$ ).
- $I_c(3n), S_c(3n)$ : Composite moment of inertia and section modulus of the steel and deck based upon 3 times the modular ratio, "3n", used for computing  $f_s$ (Total and Overload) due to long-term composite (superimposed) dead loads ( $in.^4$  and  $in.^3$ ).
- $I_c(cr), S_c(cr)$ : Composite moment of inertia and section modulus of the steel and longitudinal deck reinforcement, used for computing  $f_s$ (Total and Overload) in cracked sections, due to both short-term composite live loads and long-term composite (superimposed) dead loads ( $in.^4$  and  $in.^3$ ).
- $Z$ : Plastic Section Modulus of the steel section in non-composite areas ( $in.^3$ ).
- $p$ : Un-factored non-composite dead load (kips/ft.).
- $M_p$ : Un-factored moment due to non-composite dead load (kip-ft.).
- $s_p$ : Un-factored long-term composite (superimposed) dead load (kips/ft.).
- $M_s p$ : Un-factored moment due to long-term composite (superimposed) dead load (kip-ft.).
- $M_L$ : Un-factored live load moment (kip-ft.).
- $M_I$ : Un-factored moment due to impact (kip-ft.).
- $M_a$ : Factored design moment (kip-ft.).  
 $1.3 [M_p + M_s p + \frac{5}{3} (M_L + M_I)]$
- $M_u$ : Compact composite moment capacity according to AASHTO LFD 10.50.1.1 or compact non-composite moment capacity according to AASHTO LFD 10.48.1 (kip-ft.).
- $f_s$  (Overload): Sum of stresses as computed from the moments below (ksi).  
 $M_p + M_s p + \frac{5}{3} (M_L + M_I)$
- $f_s$  (Total): Sum of stresses as computed from the moments below on non-compact section (ksi).  
 $1.3 [M_p + M_s p + \frac{5}{3} (M_L + M_I)]$
- $VR$ : Maximum  $\tau$  + impact shear range within the composite portion of the span for stud shear connector design (kips).

INTERIOR BEAM MOMENT TABLE								
		0.4 Sp. 1	Pier 1	0.5 Sp. 3	Pier 2	0.5 Sp. 3	Pier 3	0.6 Sp. 4
$I_s$	( $in.^4$ )	7800	7800	7800	11384	7800	7800	7800
$I_c(n)$	( $in.^4$ )	21280	21280	21280	26357	21280	21280	21280
$I_c(3n)$	( $in.^4$ )	15704	15704	15704	19630	15704	15704	15704
$I_c(cr)$	( $in.^4$ )	-	10499	-	14292	-	10499	-
$S_s$	( $in.^3$ )	439	439	439	622	439	439	439
$S_c(n)$	( $in.^3$ )	655	655	655	839	655	655	655
$S_c(3n)$	( $in.^3$ )	592	592	592	767	592	592	592
$S_c(cr)$	( $in.^3$ )	-	504	-	686	-	504	-
$Z$	( $in.^3$ )	-	-	-	-	-	-	-
DL	(k/ft)	0.804	0.804	0.804	0.847	0.804	0.804	0.804
$M_{DL}$	(ft-k)	65	246	170	396	170	244	61
SDL	(k/ft)	0.18	0.18	0.18	0.18	0.18	0.18	0.18
$M_{SDL}$	(ft-k)	14	56	38	85	38	55	13
$M_{LL}$	(ft-k)	232	270	353	287	353	281	236
$M_I$	(ft-k)	70	74	90	73	90	72	60
$5/3(M_{LL+I})$	(ft-k)	503	573	740	601	740	587	494
$M_a$	(ft-k)	756	1137	1232	1406	1232	1153	739
$M_u$	(ft-k)	1922	-	1851	-	1851	-	1924
$f_s$ DL non-comp	(ksi)	1.77	6.71	4.65	7.63	4.65	6.68	1.68
$f_s$ DL (comp)	(ksi)	0.28	1.33	0.77	1.49	0.77	1.32	0.27
$f_s$ 5/3(LL+I)	(ksi)	9.21	13.67	13.55	10.50	13.55	14.00	9.05
$f_s$ (OVERLOAD)	(ksi)	11.26	21.70	18.97	19.62	18.97	22.00	10.99
$f_s$ (Total)	(ksi)	-	28.22	-	25.51	-	28.60	-
VR	(k)	54.7	58.1	42.1	55.6	42.1	58.2	54.6

INTERIOR BEAM REACTION TABLE ***						
	N. Abut.	Pier 1	Pier 2	Pier 3	S. Abut.	
$R_p$	(k)	40.5	58.7	73.7	58.5	40.2
$R_L$	(k)	35.5	42.3	40.5	42.4	35.4
$R_I$	(k)	10.6	12.7	12.2	12.7	10.6
$R_{Total}$	(k)	86.6	113.7	126.4	113.6	86.1

\* Compact section  
\*\* Braced non-compact and partially braced section  
\*\*\* Reactions are unfactored  
  
Dead load reaction at abutments include 27.0 kips for concrete diaphragm and approach pavement.

MODEL: Default  
FILE NAME: I:\10.0.0.90\Projects\2021\121221\1C - IL 78 over FAI 74 & CH 184 CADD - DWG\4.4 - Struct\0720032-68D48-017-Structural Steel Details.dgn

**TWM**  
ENGINEERING  
GEOSPATIAL SERVICES

**TWM, INC.**  
WWW.TWM-INC.COM  
IL DESIGN FIRM  
LICENSE NO:  
184-001220

USER NAME =	ckotveit	DESIGNED -	JBE	REVISED -	
		CHECKED -	CDK	REVISED -	
PLOT SCALE =	0:2.0000" = 1 in.	DRAWN -	JBE	REVISED -	
PLOT DATE =	9/22/2023	CHECKED -	CDK	REVISED -	

STATE OF ILLINOIS  
DEPARTMENT OF TRANSPORTATION

STRUCTURAL STEEL DETAILS  
STRUCTURE NO. 072-0032

SHEET 17 OF 25 SHEETS

F.A.I. RTE.	SECTION	COUNTY	TOTAL SHEETS	SHEET NO.
74	[(72-30;48-29)HB-1]BRR	PEORIA	115	46
CONTRACT NO. 68D48				
ILLINOIS FED. AID PROJECT				

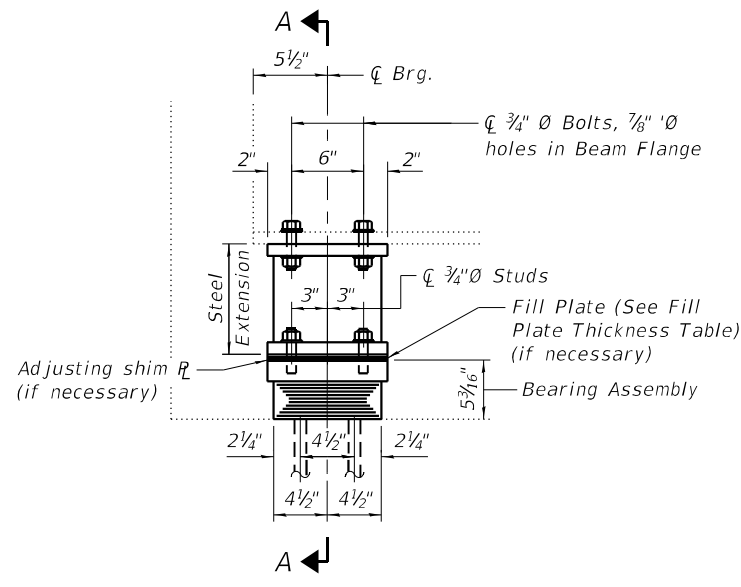

ELEVATION AT ABUT.

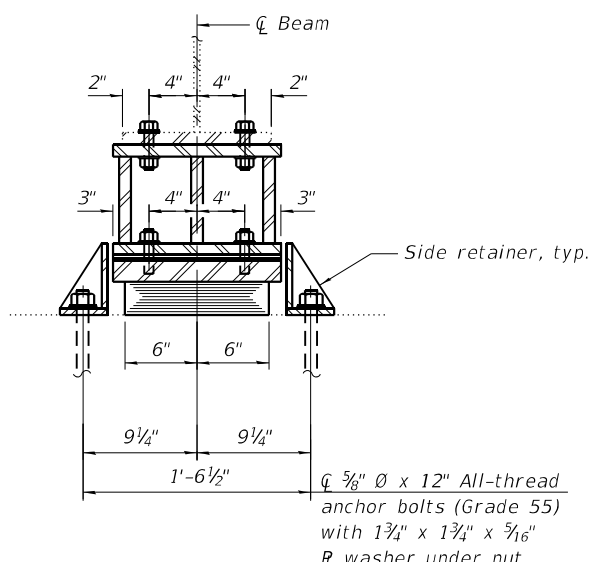

SECTION A-A

TYPE I ELASTOMERIC EXP. BRG.

**JACK AND REMOVE EXISTING BEARING PROCEDURE**

1. The Contractor shall submit for approval by the Engineer, plans for jacking existing beams and installing new bearings prior to commencing any related work. The dead load reaction per beam (weight of steel only) is 1.0 Tons at each abutment. Minimum jack capacity is 2 tons at each abutment.
2. Prior to ordering any material, the Contractor shall verify steel extension and fill plate thickness required at each bearing.
3. All existing bearings at each abutment shall be removed and replaced with Elastomeric Bearing Assembly, Type I. Bearing replacement shall be completed after removal of existing deck but prior to construction of the concrete deck.
4. Jacking lifts shall be limited in accordance with the Special Provision "Jack and Remove Existing Bearings".
5. The new bearings, plates, and steel extensions shall be in place and the jack shall be lowered before the new concrete deck is poured.

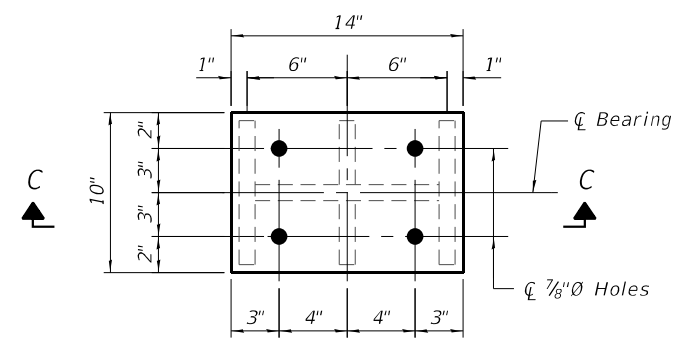

PLAN TOP AND BOTTOM PLATE

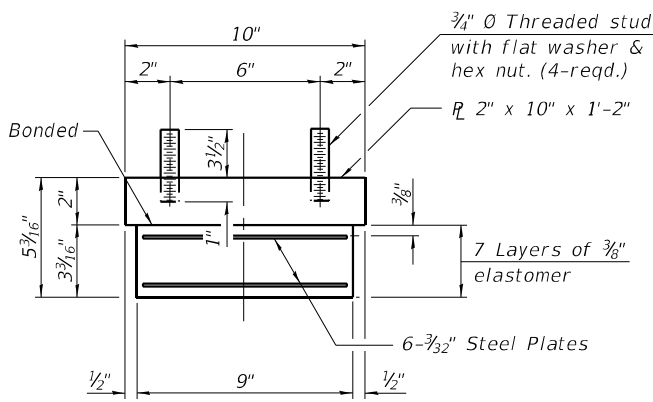

BEARING ASSEMBLY

Note:  
Shim plates shall not be placed under bearing assembly.

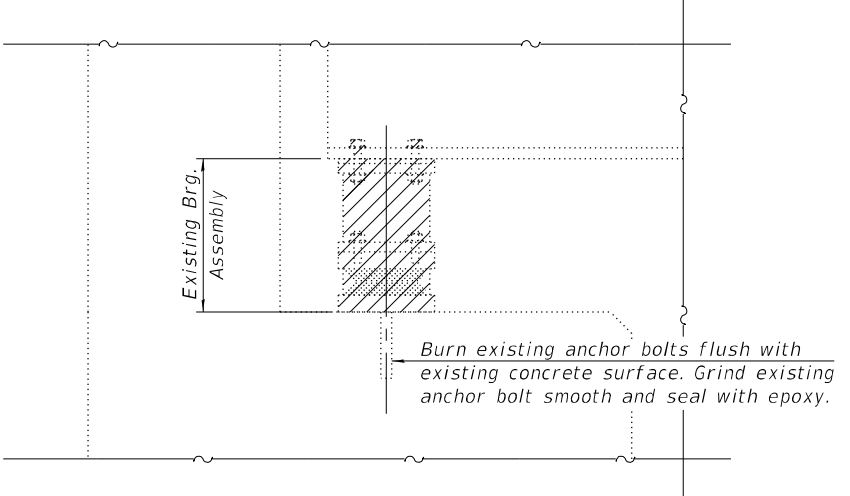

EXISTING BEARING REMOVAL DETAIL

(Cost included with Jack and Remove Existing Bearings)

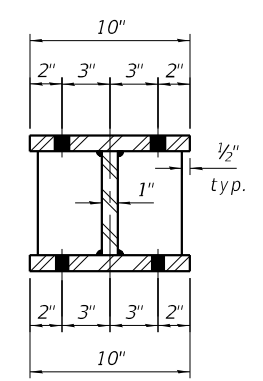

SECTION B-B

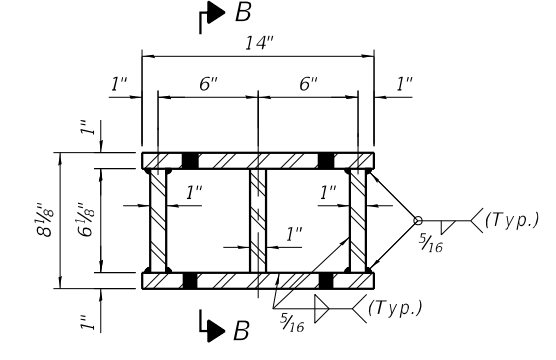

SECTION C-C

STEEL EXTENSION DETAIL

FILL PLATE THICKNESS TABLE

	Beam 1	Beam 2	Beam 3	Beam 4	Beam 5	Beam 6
N. Abut.	1/2"	1 3/16"	5/8"	5/8"	5/8"	3/4"
S. Abut.	1 5/16"	1/2"	5/8"	1 3/16"	3/4"	5/8"

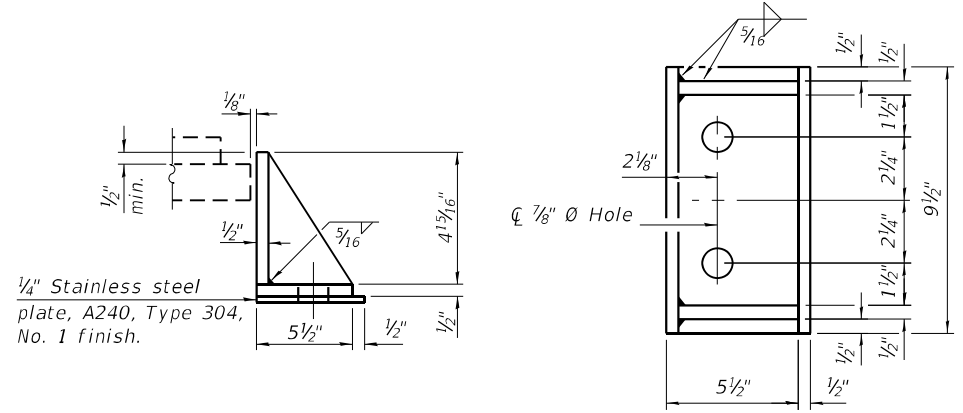

SIDE RETAINER

Equivalent rolled angle with stiffeners will be allowed in lieu of welded plates.

- Notes:
- Diaphragm removal and replacement may be required to facilitate drilling holes. Cost shall be included with Furnishing and Erecting Structural Steel.
  - New steel extensions and connection bolts are included with Furnishing and Erecting Structural Steel.
  - Two 1/8" adjusting shims shall be provided for each bearing in addition to all other plates or shims, and placed as shown on bearing details.
  - Side retainers and stainless steel plates shall be included in the cost of Elastomeric Bearing Assembly, Type I.
  - All bearing plates, steel extensions, side retainers, anchor bolts, nuts, and washers shall be galvanized according to AASHTO M111 or M232 as applicable.

**BILL OF MATERIAL**

Item	Unit	Total
Furnishing and Erecting Structural Steel	Pound	2,120
Elastomeric Bearing Assembly Type I	Each	12
Anchor Bolts, 5/8"	Each	48
Jack and Remove Existing Bearings	Each	12

MODEL: Default  
FILE NAME: I:\10.0.0.90\Projects\2021\121221\1C - IL 78 over FAI 74 & CH 18\4 CADD - DWG\4.4 - Struct\0720032-68D48-018-Abutment Bearing Details.dgn



TWM, INC.  
www.twm-inc.com  
IL DESIGN FIRM LICENSE NO: 184-001220

USER NAME =	ckotveit	DESIGNED -	JBE	REVISED -	
PLOT SCALE =	0:2.0000" = 1 in.	CHECKED -	CDK	REVISED -	
PLOT DATE =	9/22/2023	DRAWN -	JBE	REVISED -	
		CHECKED -	CDK	REVISED -	

STATE OF ILLINOIS  
DEPARTMENT OF TRANSPORTATION

ABUTMENT BEARING DETAILS  
STRUCTURE NO. 072-0032  
SHEET 18 OF 25 SHEETS

F.A.I. RTE.	SECTION	COUNTY	TOTAL SHEETS	SHEET NO.
74	[(72-30;48-29)HB-1]BRR	PEORIA	115	47
CONTRACT NO. 68D48				
ILLINOIS FED. AID PROJECT				

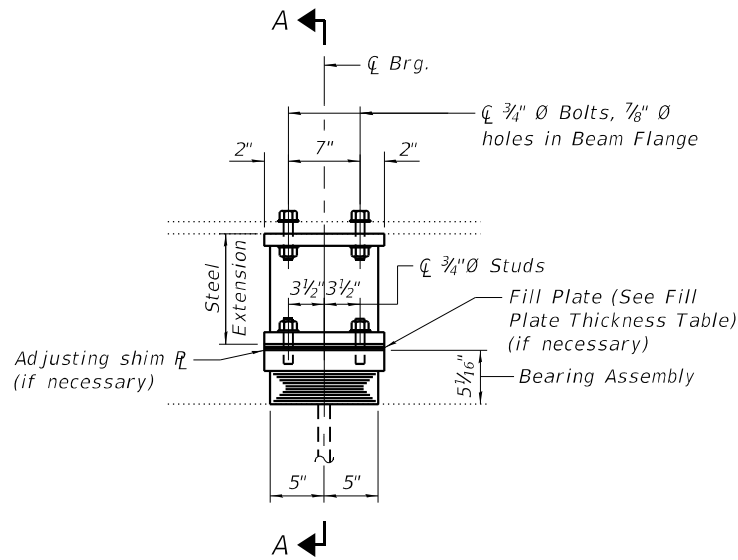

ELEVATION AT PIERS 1 & 3

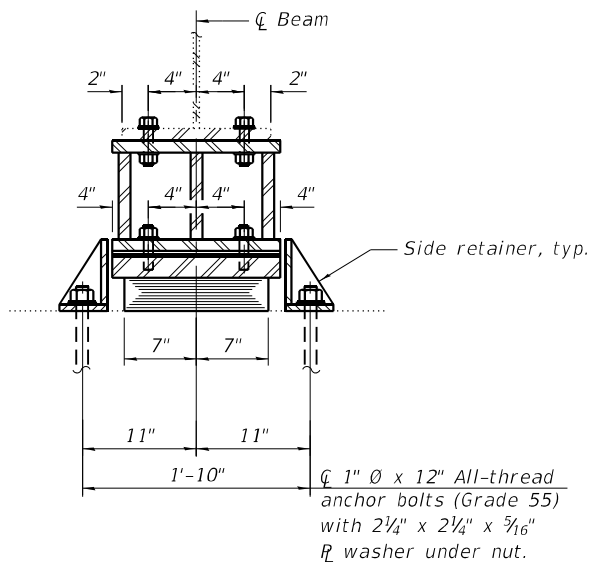

SECTION A-A

TYPE I ELASTOMERIC EXP. BRG.

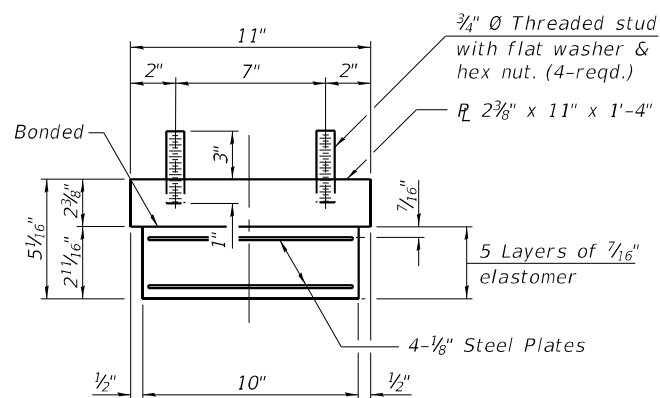

BEARING ASSEMBLY

Note:  
Shim plates shall not be placed under bearing assembly.

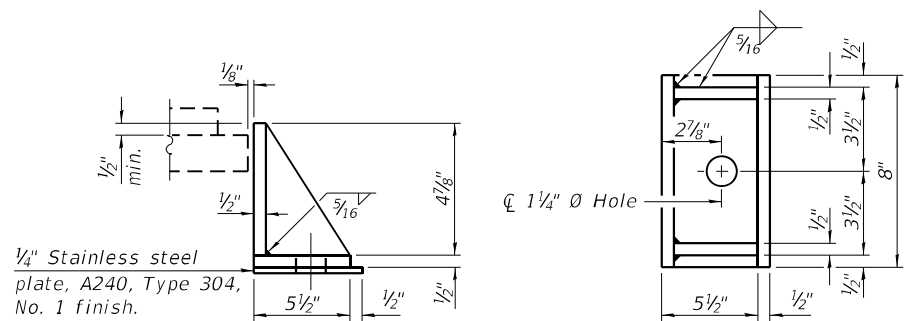

SIDE RETAINER

Equivalent rolled angle with stiffeners will be allowed in lieu of welded plates.

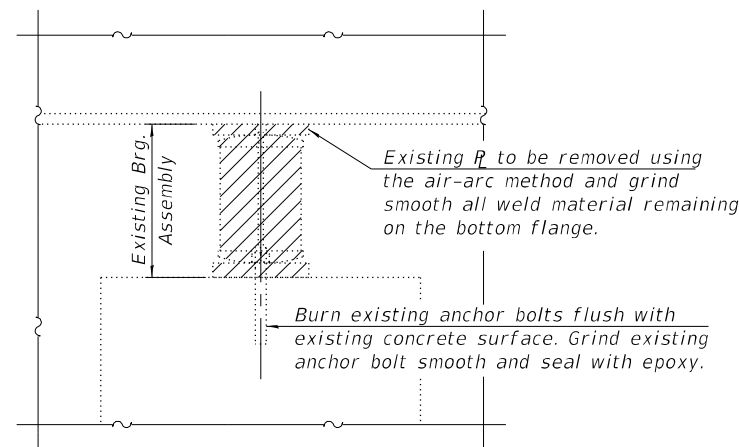

EXISTING BEARING REMOVAL DETAIL

(Cost included with Jack and Remove Existing Bearings)

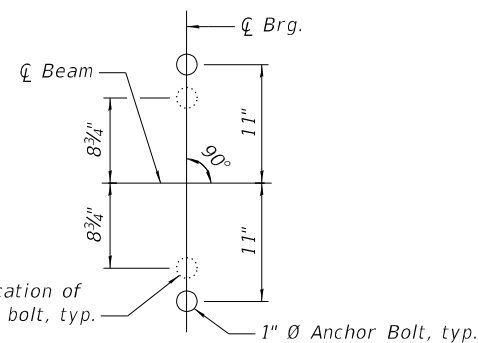

ANCHOR BOLT LOCATION

JACK AND REMOVE EXISTING BEARING PROCEDURE

1. The Contractor shall submit for approval by the Engineer, plans for jacking existing beams and installing new bearings prior to commencing any related work. The dead load reaction per beam (weight of steel only) is 4.4 tons at Piers 1 and 3. Minimum jack capacity is 8 tons at each pier.
2. Prior to ordering any material, the Contractor shall verify steel extension and fill plate thickness required at each bearing.
3. All existing bearings at each abutment shall be removed and replaced with Elastomeric Bearing Assembly, Type I. Bearing replacement shall be completed after removal of existing deck but prior to construction of the concrete deck.
4. Jacking lifts shall be limited in accordance with the Special Provision "Jack and Remove Existing Bearings".
5. The new bearings, plates, and steel extensions shall be in place and the jack shall be lowered before the new concrete deck is poured.

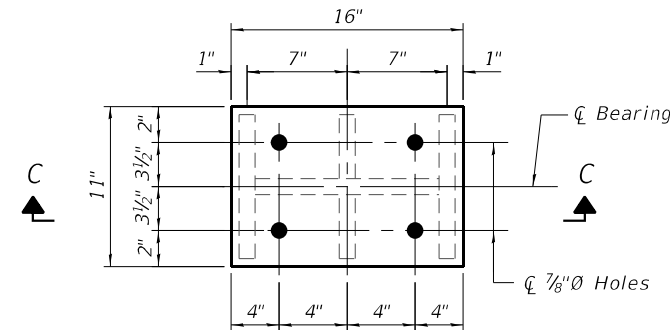

PLAN TOP AND BOTTOM PLATE

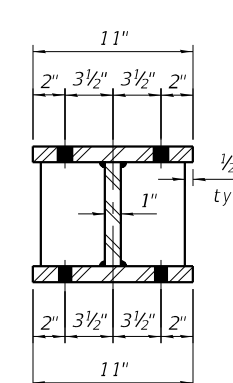

SECTION B-B

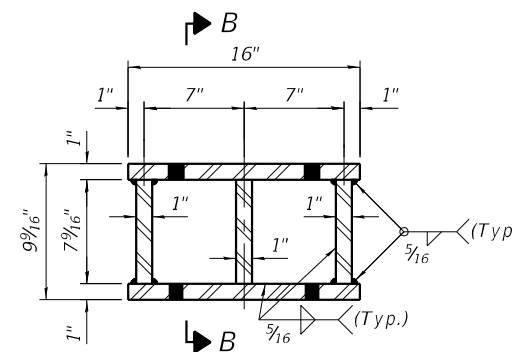

SECTION C-C

STEEL EXTENSION DETAIL

FILL PLATE THICKNESS TABLE

	Beam 1	Beam 2	Beam 3	Beam 4	Beam 5	Beam 6
Pier 1	3/8"	1/4"	1/2"	1/2"	1/2"	1/4"
Pier 3	1/4"	1/2"	1/4"	3/8"	1/2"	3/8"

- Notes:
- Diaphragm removal and replacement may be required to facilitate drilling holes. Cost shall be included with Furnishing and Erecting Structural Steel.
  - New steel extensions and connection bolts are included with Furnishing and Erecting Structural Steel.
  - Two 1/8" adjusting shims shall be provided for each bearing in addition to all other plates or shims, and placed as shown on bearing details.
  - Side retainers and stainless steel plates shall be included in the cost of Elastomeric Bearing Assembly, Type I.
  - All bearing plates, steel extensions, side retainers, anchor bolts, nuts, and washers shall be galvanized according to AASHTO M111 or M232 as applicable.

BILL OF MATERIAL

Item	Unit	Total
Furnishing and Erecting Structural Steel	Pound	2,580
Elastomeric Bearing Assembly Type I	Each	12
Anchor Bolts, 1"	Each	24
Jack and Remove Existing Bearings	Each	12

MODEL: Default FILE NAME: I:\10.0.0.90\Projects\2021\12112211C - IL 78 over FAI 74 & CH 18\4 CADD - DWG\4.4 - Struct\0720032-68D48-019-Pier 1 and Pier 3 Bearing Details.dgn



TWM, INC.  
www.twm-inc.com  
ILLINOIS DESIGN FIRM LICENSE NO: 184-001220

USER NAME = cktovell	DESIGNED - JBE	REVISED -
PLOT SCALE = 0:2,0000 "/>		

STATE OF ILLINOIS  
DEPARTMENT OF TRANSPORTATION

PIER 1 AND PIER 3 BEARING DETAILS  
STRUCTURE NO. 072-0032

SHEET 19 OF 25 SHEETS

F.A.I. RTE.	SECTION	COUNTY	TOTAL SHEETS	SHEET NO.
74	[(72-30;48-29)HB-1]BRR	PEORIA	115	48
CONTRACT NO. 68D48				
ILLINOIS FED. AID PROJECT				



MODEL: Default  
 FILE NAME: I:\10.0.0.90\Projects\2021\12\11221\1C - IL 78 over FAI 74 & CH 184 CADD - DWG\4.4 - Struct\0720032-68D48-020-Abutment Removal Details.dgn

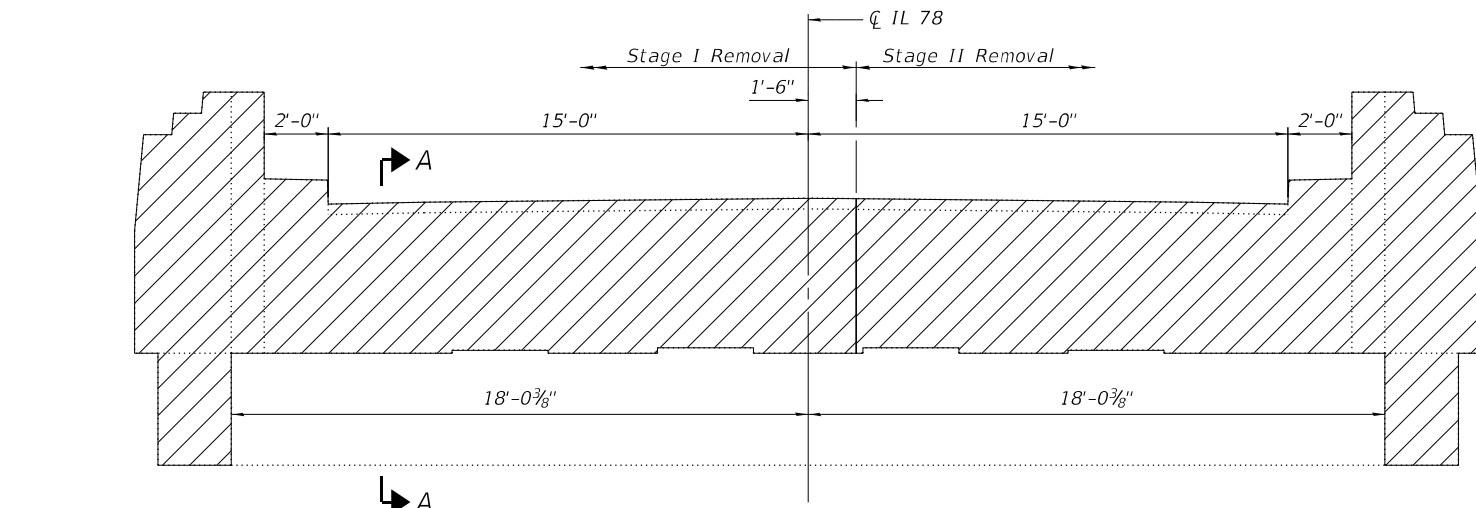

**ELEVATION**

(South Abutment shown, looking south - North Abutment similar)

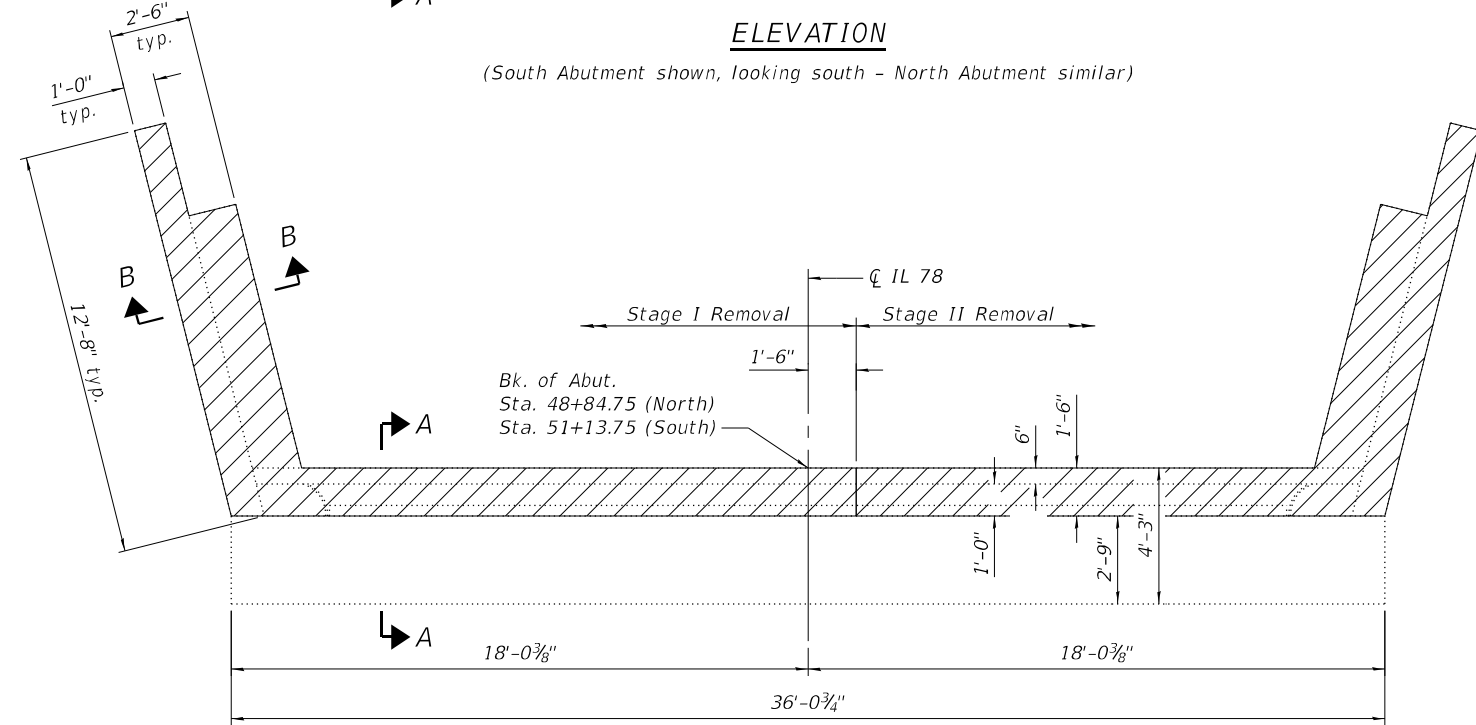

**TOP PLAN**

(South Abutment shown, North Abutment similar)

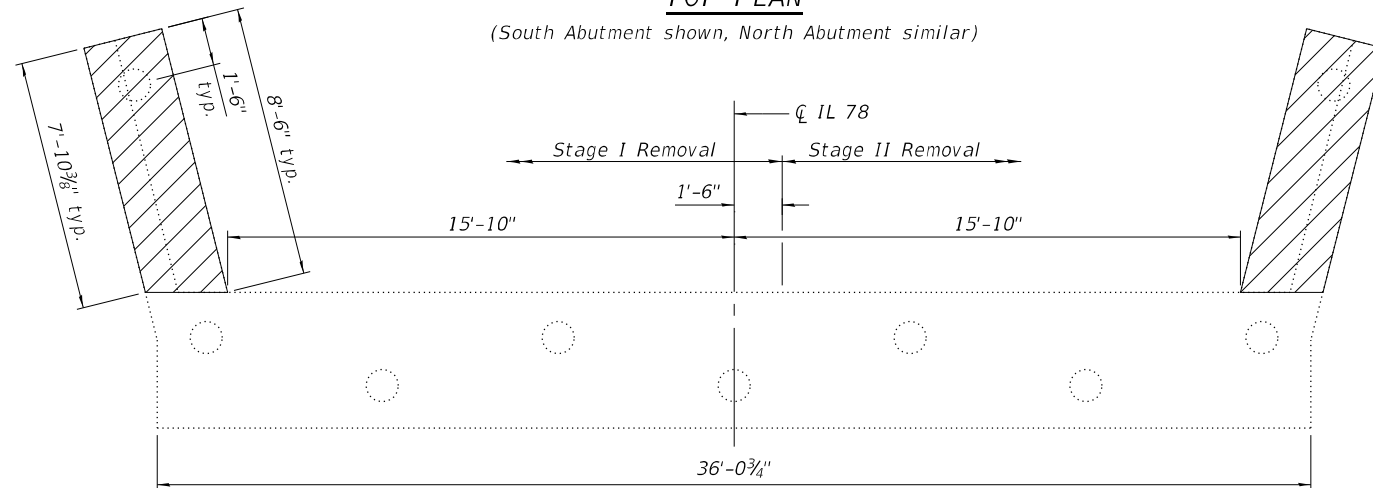

**PLAN - PILE CAP**

(South Abutment shown, North Abutment similar)

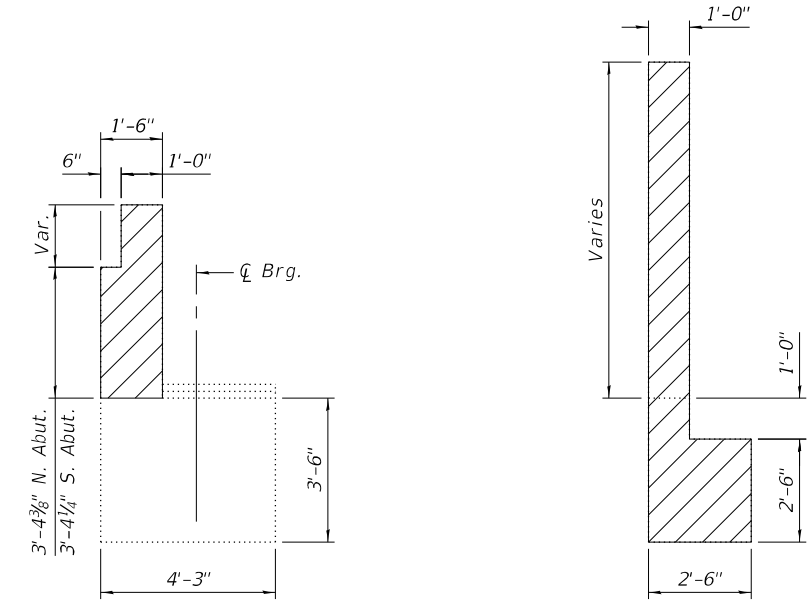

**SECTION A-A**

**SECTION B-B**

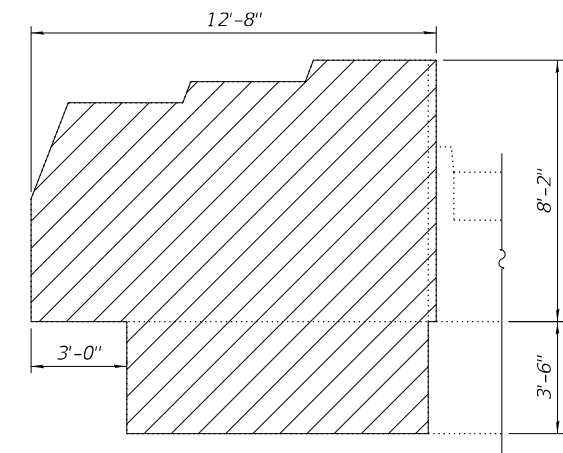

**WINGWALL REMOVAL**

**Notes:**

Existing reinforcement shall be cleaned, straightened and incorporated into the new construction. Cost included with Concrete Removal.  
 Hatched areas indicate Concrete Removal  
 Any reinforcement bars that are damaged during concrete removal operation shall be repaired or replaced using an approved bar splicer or anchorage system. Cost included with "Concrete Removal".

**BILL OF MATERIAL - 2 ABUTMENTS**

Item	Unit	Total
Concrete Removal	Cu. Yd.	39.3



**TWM, INC.**  
 www.twm-inc.com  
 IL DESIGN FIRM  
 LICENSE NO:  
 184-001220

USER NAME = cktovt  
 DESIGNED - JBE  
 CHECKED - CDK  
 DRAWN - JBE  
 PLOT SCALE = 0:2,0000 "/in.  
 CHECKED - CDK  
 PLOT DATE = 9/22/2023

DESIGNED - JBE  
 CHECKED - CDK  
 DRAWN - JBE  
 CHECKED - CDK  
 REVISED -  
 REVISED -  
 REVISED -  
 REVISED -

**STATE OF ILLINOIS  
 DEPARTMENT OF TRANSPORTATION**

**ABUTMENT REMOVAL DETAILS  
 STRUCTURE NO. 072-0032**

SHEET 20 OF 25 SHEETS

F.A.I. RTE.	SECTION	COUNTY	TOTAL SHEETS	SHEET NO.
74	[(72-30;48-29)HB-1]BRR	PEORIA	115	49
CONTRACT NO. 68D48				

ILLINOIS FED. AID PROJECT

MODEL: Default  
 FILE NAME: \\110.0.0.90\Projects\2021\112211C - IL 78 over FAI 74 & CH 184 CADD - DWG\4.4 - Struct\0720032-68D48-02-1-North Abutment.dgn

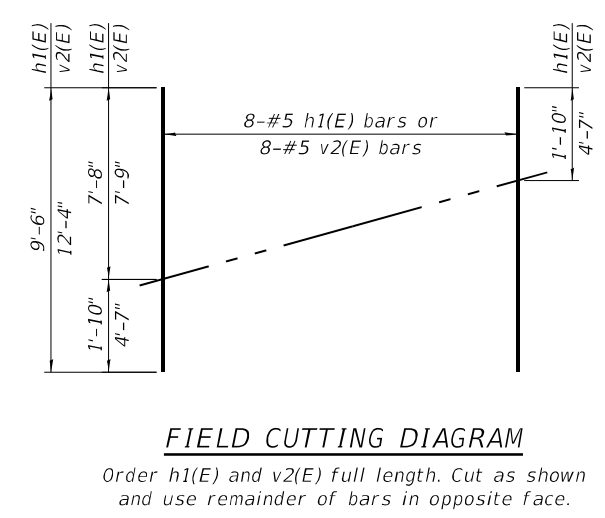
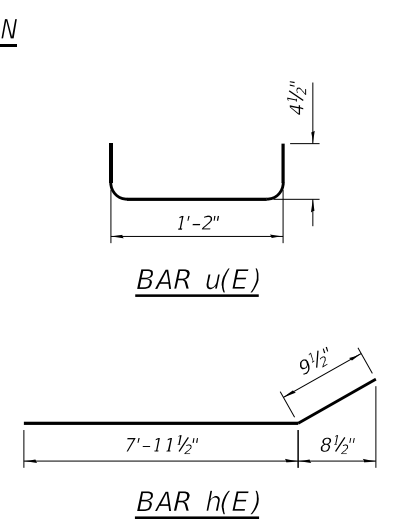
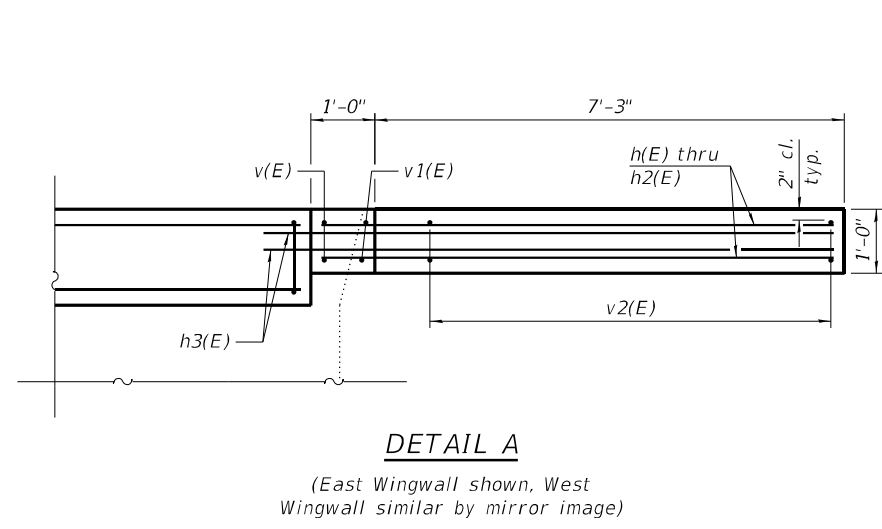
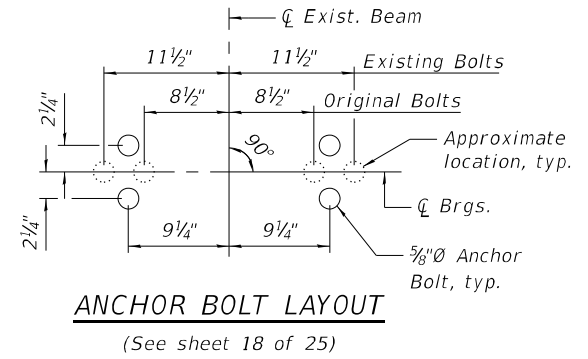
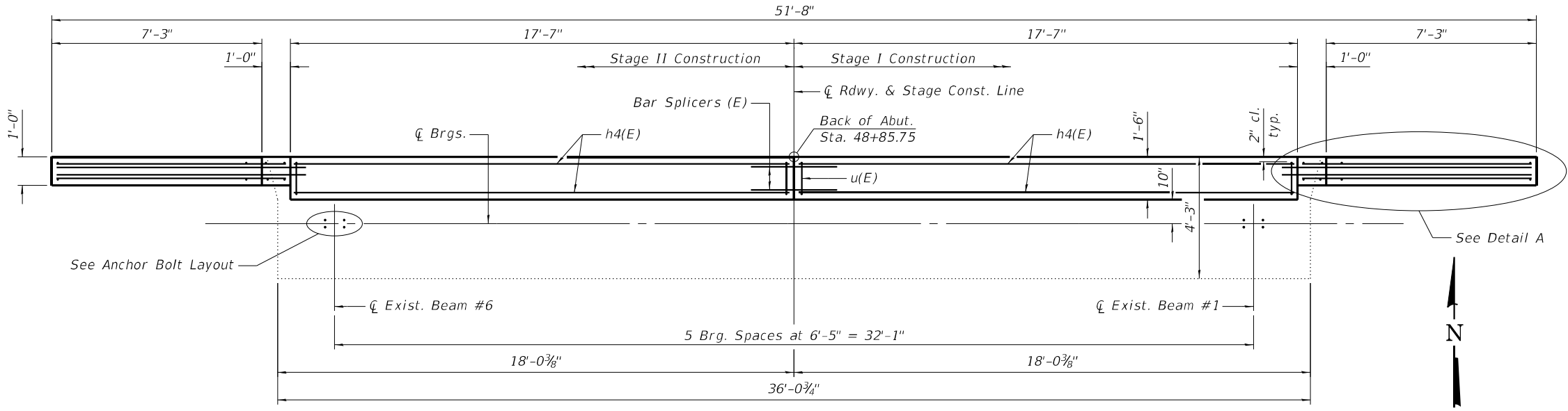
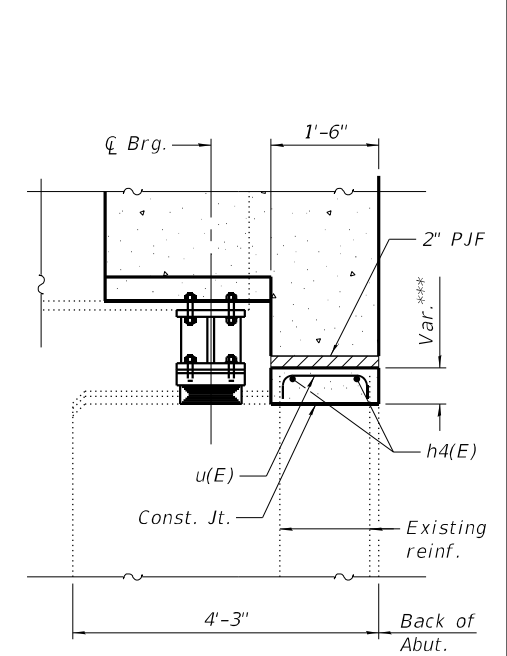
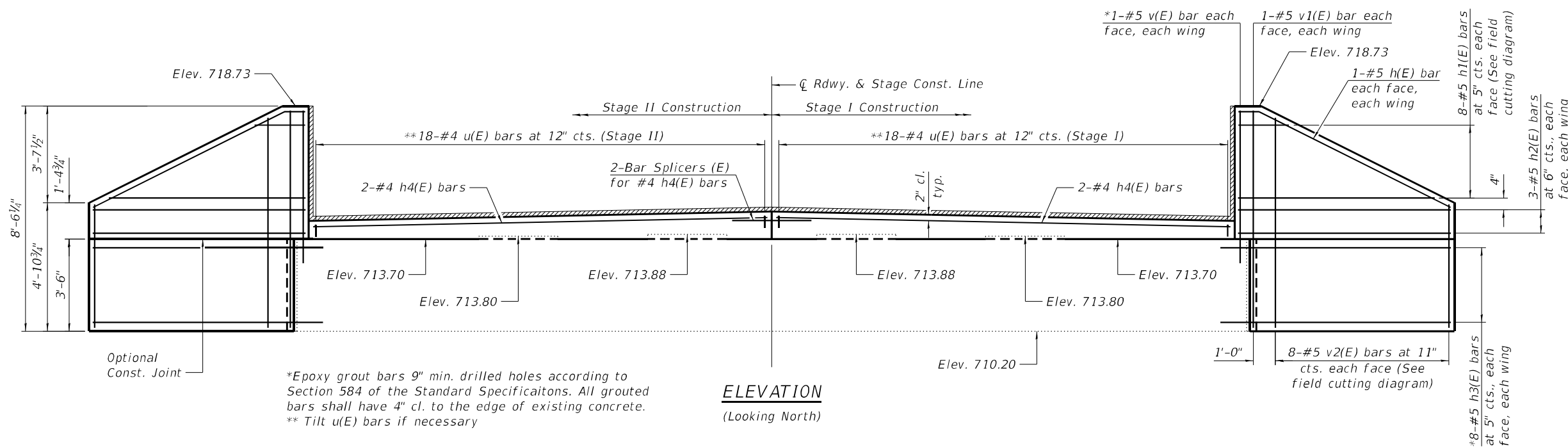

**BILL OF MATERIAL**

Bar	No.	Size	Length	Shape
h(E)	4	#5	8'-9"	
h1(E)	16	#5	9'-6"	
h2(E)	12	#5	7'-11"	
h3(E)	32	#5	8'-3"	
h4(E)	4	#4	17'-3"	
u(E)	36	#4	1'-11"	
v(E)	4	#5	5'-7"	
v1(E)	4	#5	8'-2"	
v2(E)	16	#5	12'-4"	
Structure Excavation			Cu. Yd.	88
Concrete Structures			Cu. Yd.	5.1
Reinforcement Bars, Epoxy Coated			Pound	930



USER NAME =	ckotveit	DESIGNED -	JBE	REVISED -	
PLOT SCALE =	0:2,0000 "/in.	CHECKED -	CDK	REVISED -	
PLOT DATE =	9/22/2023	DRAWN -	JBE	REVISED -	
		CHECKED -	CDK	REVISED -	

STATE OF ILLINOIS  
 DEPARTMENT OF TRANSPORTATION

NORTH ABUTMENT  
 STRUCTURE NO. 072-0032

SHEET 21 OF 25 SHEETS

F.A.I. RTE.	SECTION	COUNTY	TOTAL SHEETS	SHEET NO.
74	[(72-30;48-29)HB-1]BRR	PEORIA	115	50
CONTRACT NO. 68D48				
ILLINOIS / FED. AID PROJECT				

MODEL: Default  
 FILE NAME: \\110.0.0.90\Projects\2021\112211C - IL 78 over FAI 74 & CH 184 CADD - DWG\4.4 Struct\0720032-68D48-02-2-South Abutment.dgn

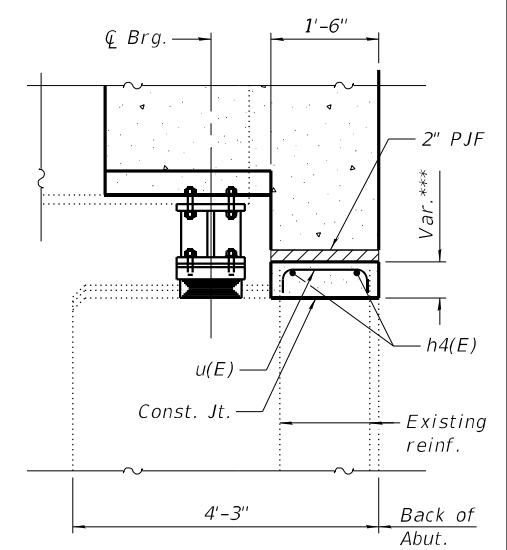
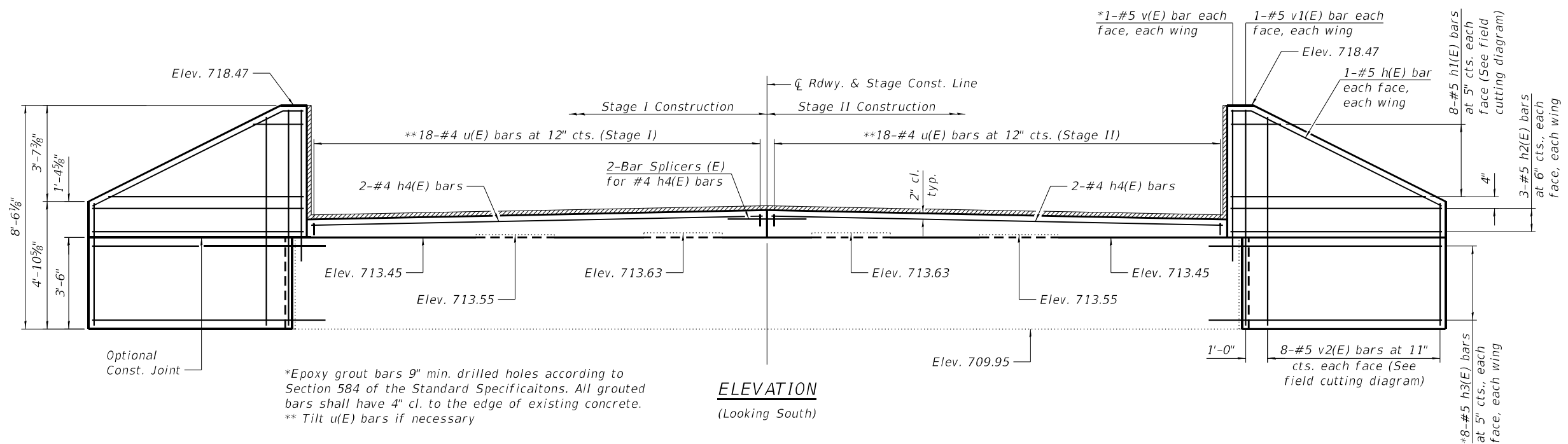

\*\*\* See View B-B on sheet 13 of 25 for dimensions.

Note:  
 Existing reinforcement to be cleaned, straightened and reused.

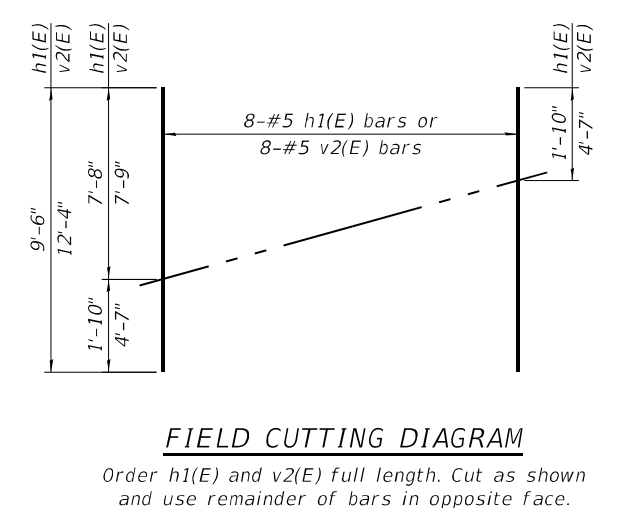
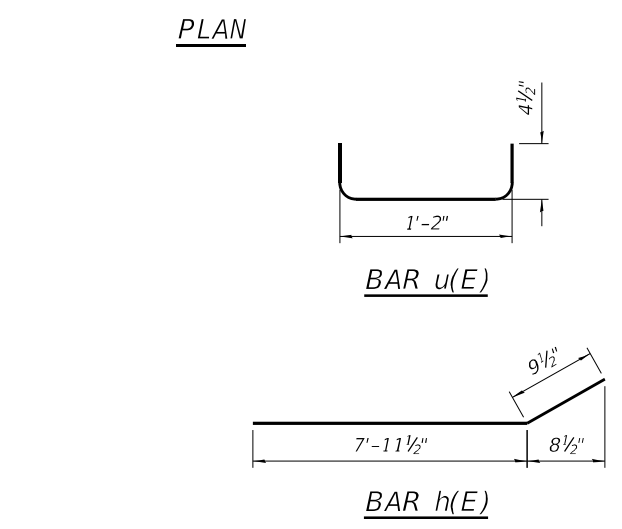
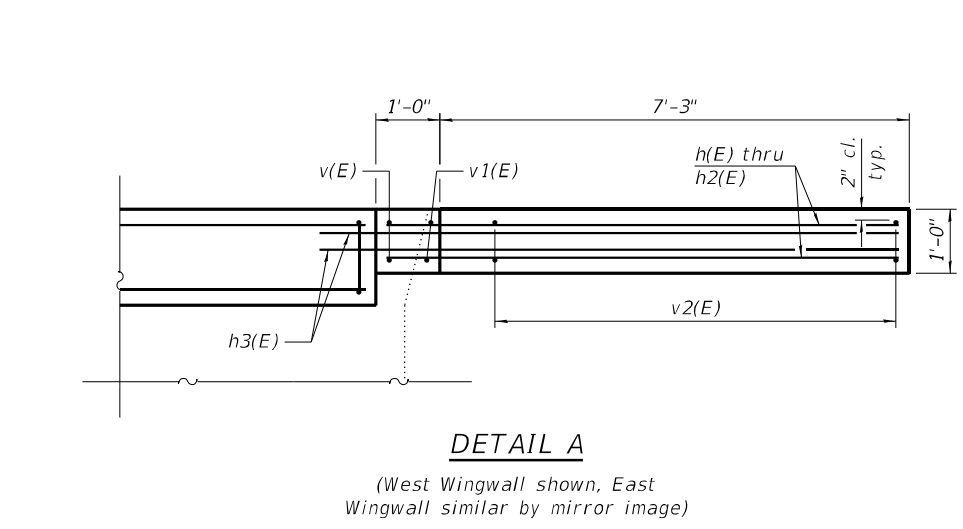
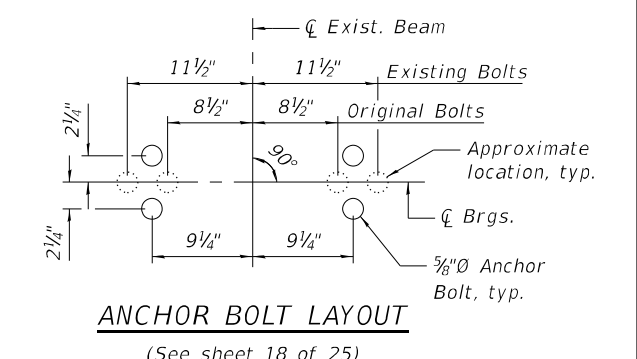
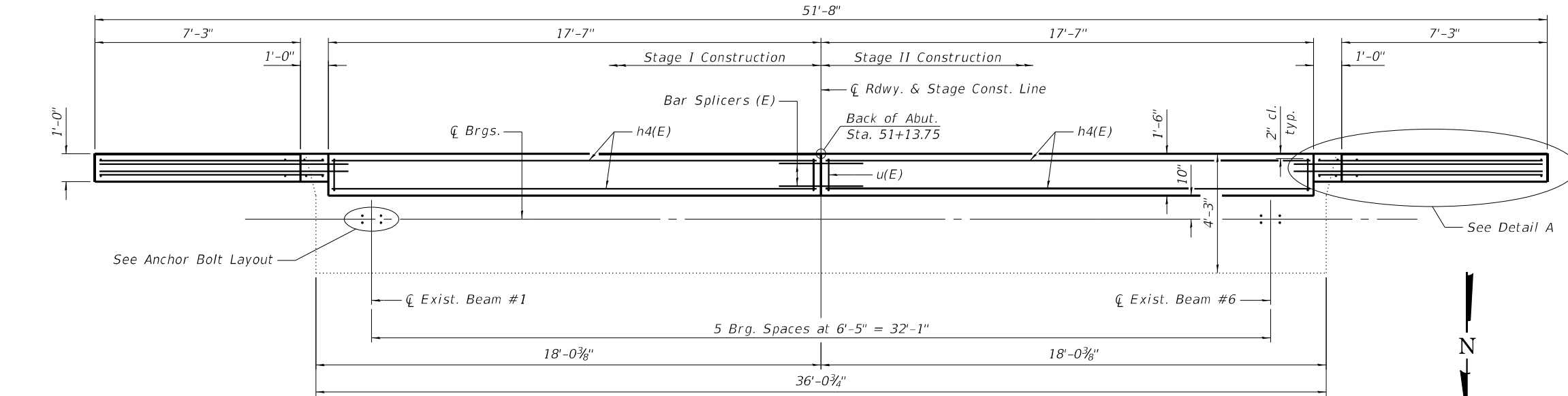

**BILL OF MATERIAL**

Bar	No.	Size	Length	Shape
h(E)	4	#5	8'-9"	
h1(E)	16	#5	9'-6"	
h2(E)	12	#5	7'-11"	
h3(E)	32	#5	8'-3"	
h4(E)	4	#4	17'-3"	
u(E)	36	#4	1'-11"	
v(E)	4	#5	5'-7"	
v1(E)	4	#5	8'-2"	
v2(E)	16	#5	12'-4"	
Structure Excavation		Cu. Yd.	84	
Concrete Structures		Cu. Yd.	5.1	
Reinforcement Bars, Epoxy Coated		Pound	930	



**TWM, INC.**  
 www.twm-inc.com  
 IL DESIGN FIRM LICENSE NO: 184-001220

USER NAME = ckotveit  
 DESIGNED - JBE  
 CHECKED - CDK  
 DRAWN - JBE  
 PLOT SCALE = 0:2,0000" = 1/16"  
 PLOT DATE = 9/22/2023

REVISD -  
 REVISD -  
 REVISD -  
 REVISD -

**STATE OF ILLINOIS  
 DEPARTMENT OF TRANSPORTATION**

**SOUTH ABUTMENT  
 STRUCTURE NO. 072-0032**

SHEET 22 OF 25 SHEETS

F.A.I. RTE.	SECTION	COUNTY	TOTAL SHEETS	SHEET NO.
74	[(72-30;48-29)HB-1]BRR	PEORIA	115	51
CONTRACT NO. 68D48				
ILLINOIS / FED. AID PROJECT				

MODEL: Default  
 FILE NAME: \\10.0.0.90\Projects\2021\11221\1C - IL 78 over FAI 74 & CH 18\4 CADD - DWG\4.4 Struct\0720032-68D48-023\Pier 1 and Pier 2 Repair Details.dgn



PIER 1 TOP PLAN

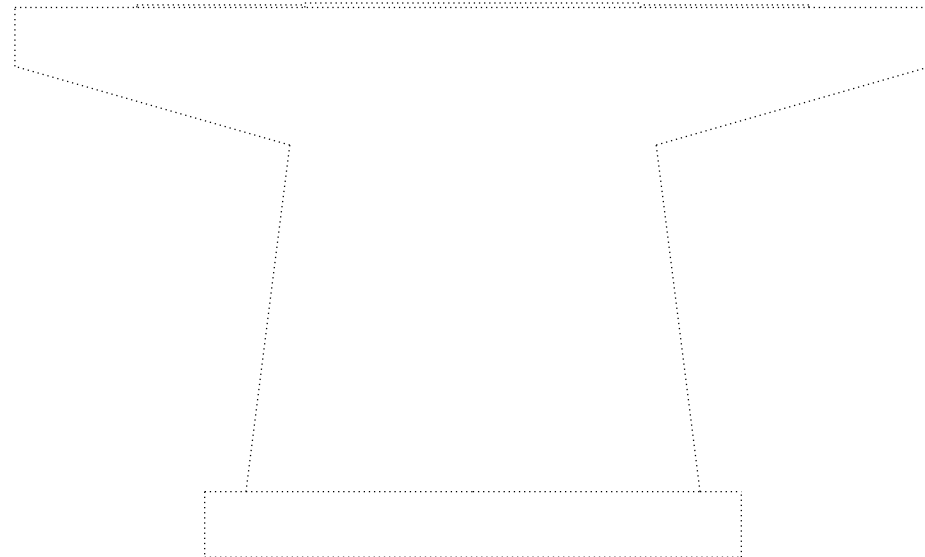

PIER 1 ELEVATION  
 (Looking North)

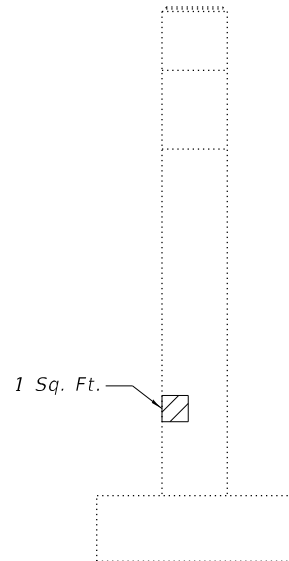

PIER 1 END VIEW  
 (Looking West)

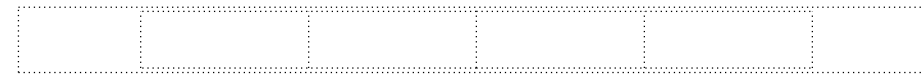

PIER 2 TOP PLAN

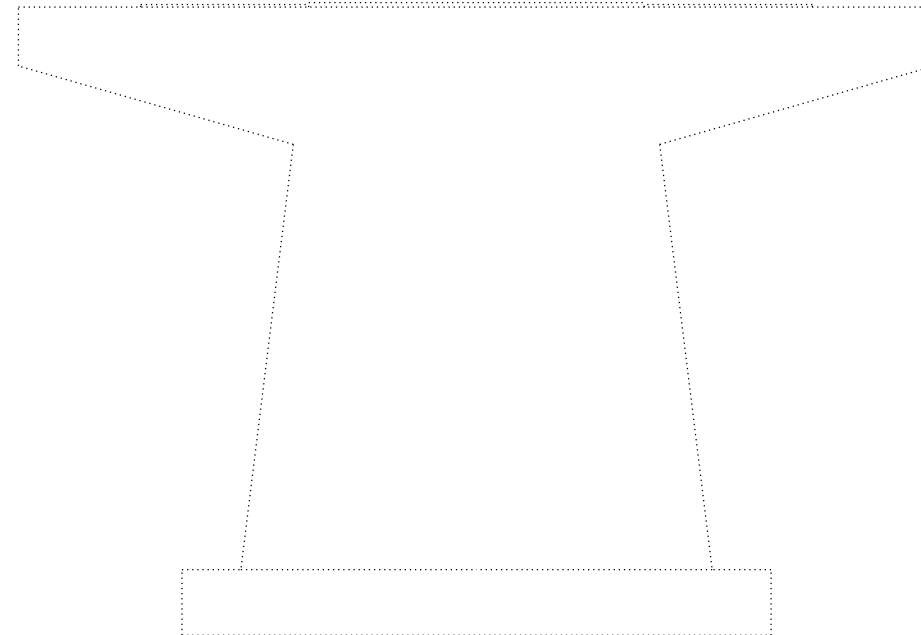

PIER 2 ELEVATION  
 (Looking North)

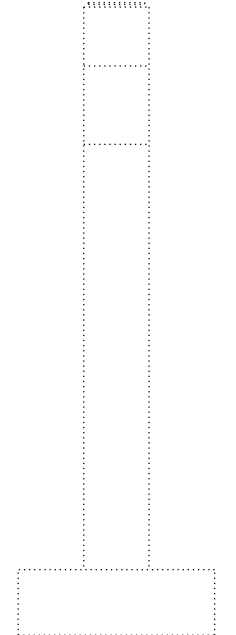

PIER 2 END VIEW  
 (Looking West)

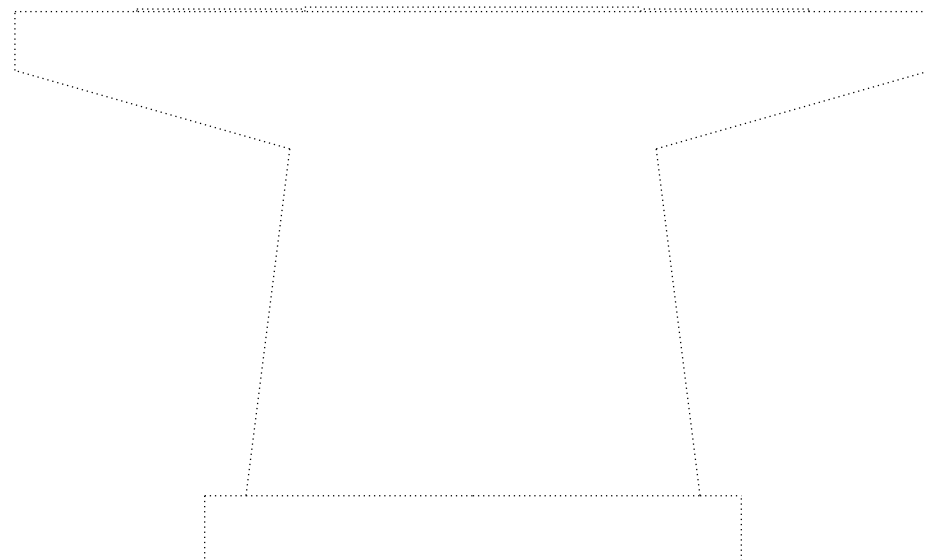

PIER 1 ELEVATION  
 (Looking South)

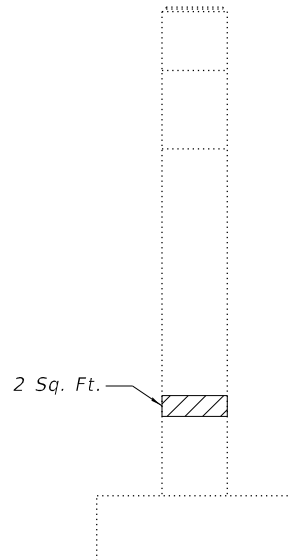

PIER 1 END VIEW  
 (Looking East)

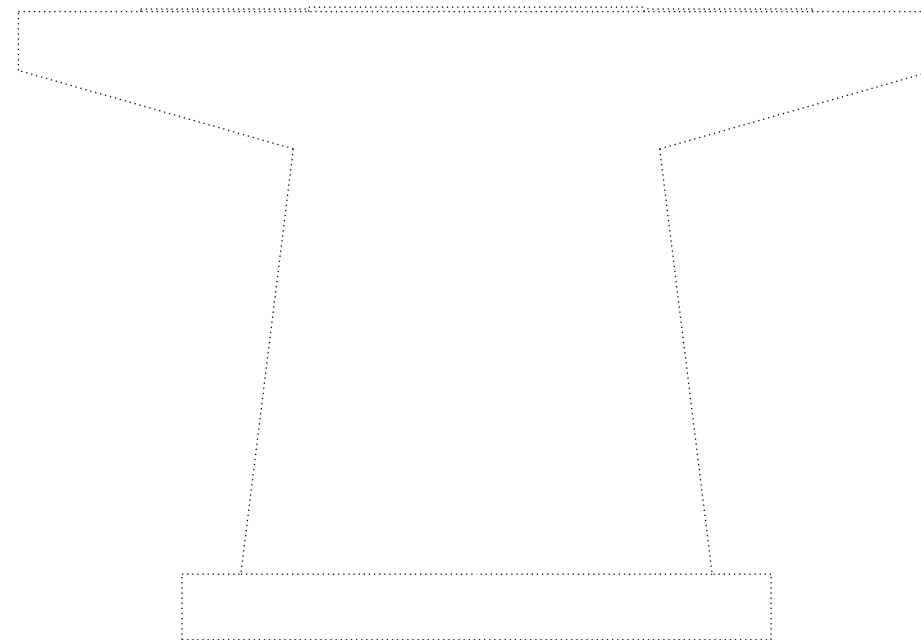

PIER 2 ELEVATION  
 (Looking South)

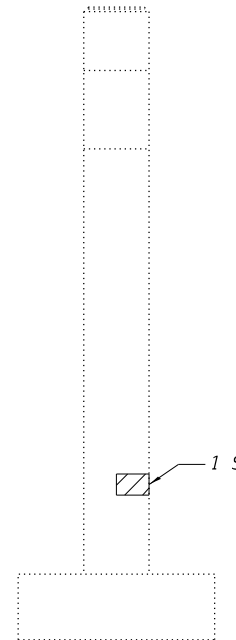

PIER 2 END VIEW  
 (Looking East)

**LEGEND**

Structural Repair of Concrete  
 (Depth Equal to or Less than 5 in.)

**BILL OF MATERIAL**

Item	Unit	Total
Structural Repair of Concrete (Depth Equal to or Less than 5 Inches)	Sq. Ft.	4

**Notes:**

Repair of existing piers shall include but may not be limited to the areas shown. The actual areas to be repaired shall be determined by the Engineer at the time of construction. See Special Provisions



**TWM, INC.**  
 www.twm-inc.com  
 IL DESIGN FIRM  
 LICENSE NO:  
 184-001220

USER NAME = cktovell  
 DESIGNED - JBE  
 CHECKED - CDK  
 PLOT SCALE = 0:2.0000 "/ in.  
 DRAWN - JBE  
 CHECKED - CDK  
 PLOT DATE = 9/22/2023

DESIGNED - JBE  
 CHECKED - CDK  
 REVISED -  
 REVISED -  
 REVISED -  
 REVISED -

**STATE OF ILLINOIS  
 DEPARTMENT OF TRANSPORTATION**

**PIER 1 AND PIER 2 REPAIR DETAILS  
 STRUCTURE NO. 072-0032**

SHEET 23 OF 25 SHEETS

F.A.I. RTE.	SECTION	COUNTY	TOTAL SHEETS	SHEET NO.
74	[(72-30;48-29)HB-1]BRR	PEORIA	115	52
CONTRACT NO. 68D48				

ILLINOIS FED. AID PROJECT

MODEL: Default  
 FILE NAME: \\110.0.0.90\Projects\2021\11221\1C - IL 78 over FAI 74 & CH 18\4 CADD - DWG\4.4 - Struct\0720032-68D48-024-Concrete Parapet Slipforming Option.dgn

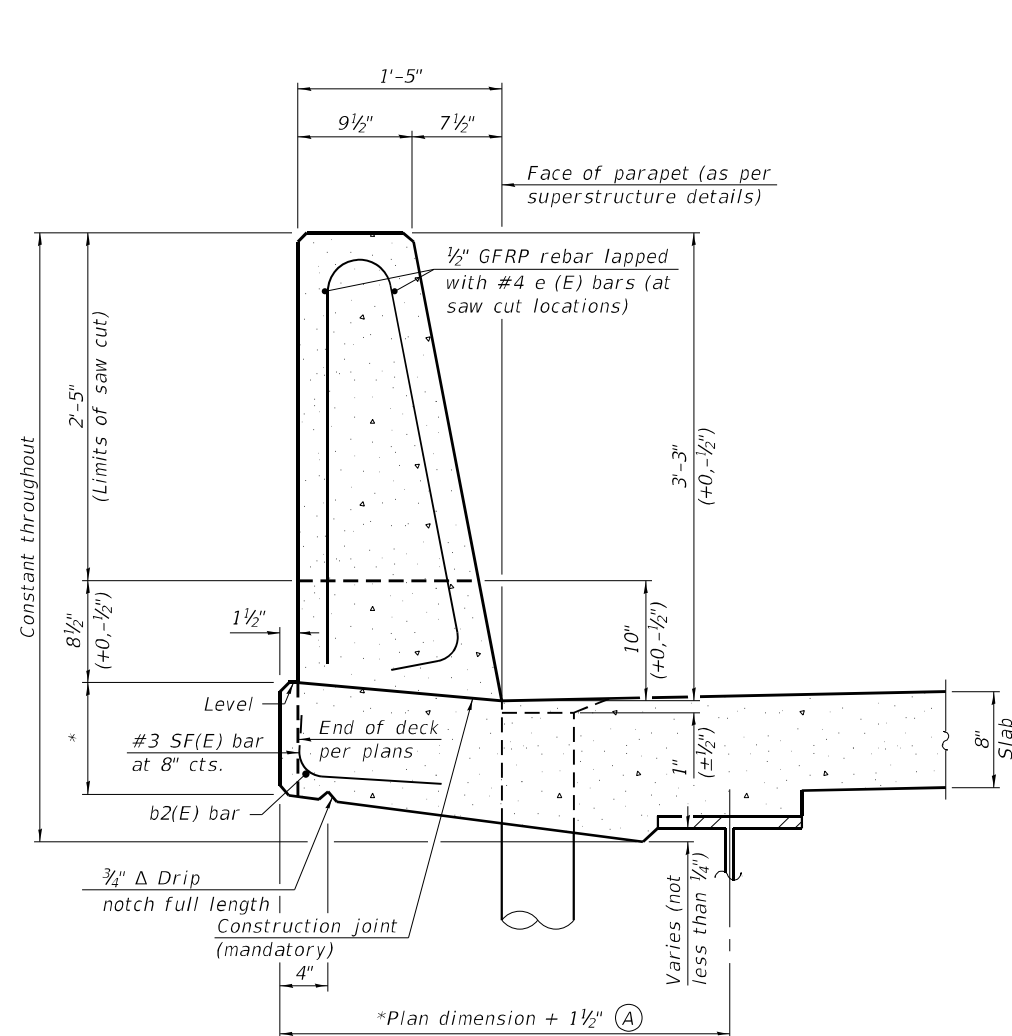

**39" CONSTANT-SLOPE PARAPET SECTION**

(Showing dimensions, d(E), and 1/2" Ø GFRP rebar)

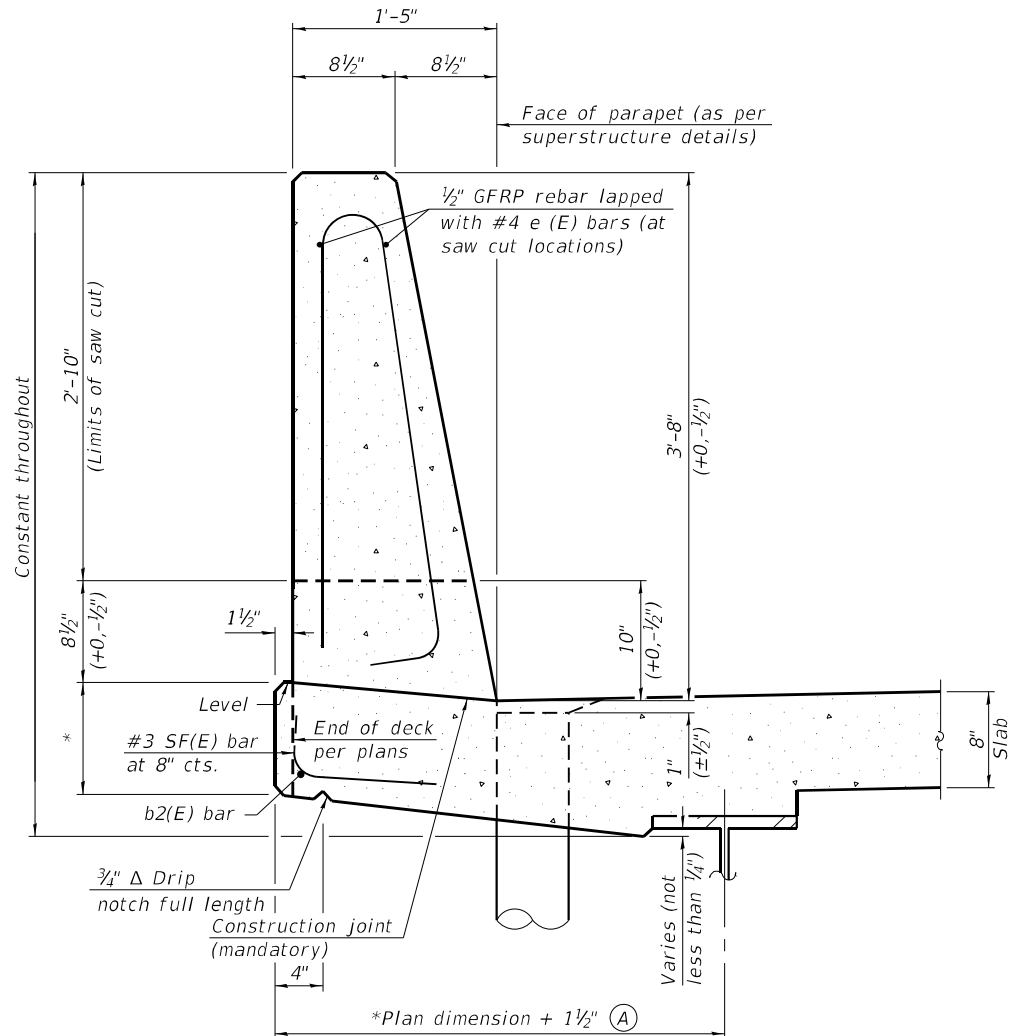

**44" CONSTANT-SLOPE PARAPET SECTION**

(Showing dimensions, d(E), and 1/2" Ø GFRP rebar)

\*See Superstructure Details.

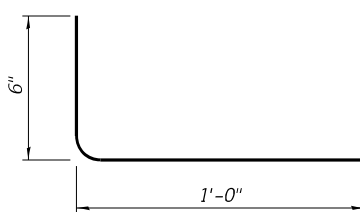

**SF(E) BAR**

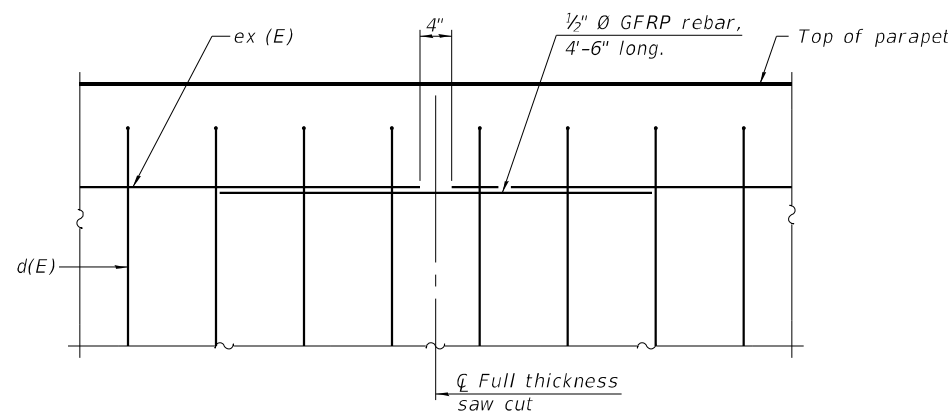

**GFRP REBAR STIFFENING DETAIL**

(Place as shown in parapet section at each parapet joint location.)

Notes:  
 All dimensions shall remain the same as shown on superstructure details, except dimension A which is to be revised as shown. Additional concrete needed to revise dimension A = 0.00348 cu. yds./ft. for 39" and 44" parapets.  
 Place full depth aluminum sheets as shown on superstructure details.  
 Replace all cork joint filler locations with a full thickness saw cut.  
 Steel superstructure shown. Other superstructure types similar.

SFP 39-44

11-1-2022



USER NAME =	ckotveit	DESIGNED -	JBE	REVISED -	
CHECKED -	CDK	CHECKED -	CDK	REVISED -	
PLOT SCALE =	0:2.0000" = 1 in.	DRAWN -	JBE	REVISED -	
PLOT DATE =	9/22/2023	CHECKED -	CDK	REVISED -	

STATE OF ILLINOIS  
 DEPARTMENT OF TRANSPORTATION

CONCRETE PARAPET SLIPFORMING OPTION  
 STRUCTURE NO. 072-0032

SHEET 24 OF 25 SHEETS

F.A.I. RTE.	SECTION	COUNTY	TOTAL SHEETS	SHEET NO.
74	[(72-30;48-29)HB-1]BRR	PEORIA	115	53
CONTRACT NO. 68D48				

ILLINOIS FED. AID PROJECT

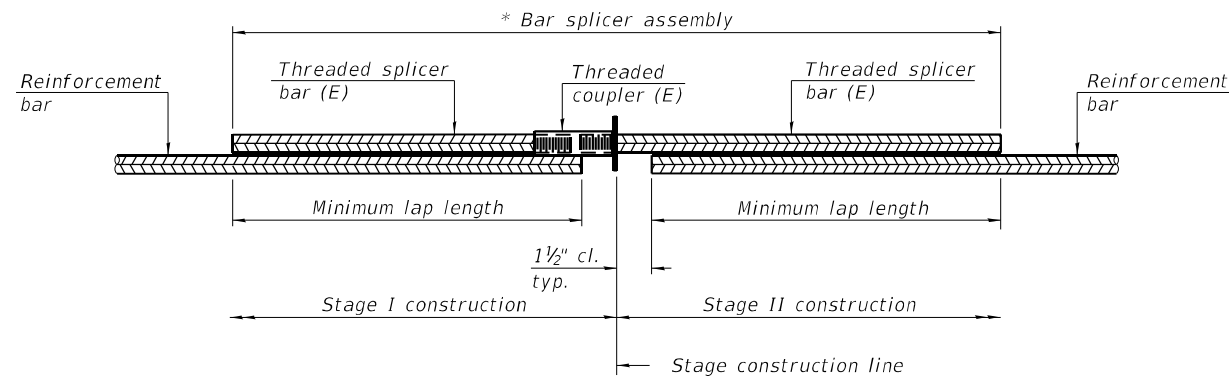

**STANDARD BAR SPLICER ASSEMBLY PLAN**

Only bar splicer assemblies as presented on the approved QPL list may be used.

Threaded splicer bar length = min. lap length + 1 1/2" + thread length

\* Epoxy not required on Bar Splicer Assembly components used in conjunction with black bars.

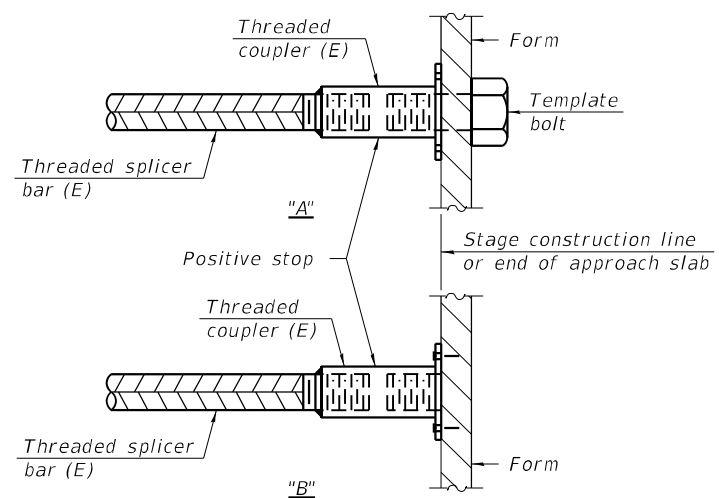

**INSTALLATION AND SETTING METHODS**

"A" : Set bar splicer assembly by means of a template bolt.

"B" : Set bar splicer assembly by nailing to wood forms or cementing to steel forms.

(E) : Indicates epoxy coating.

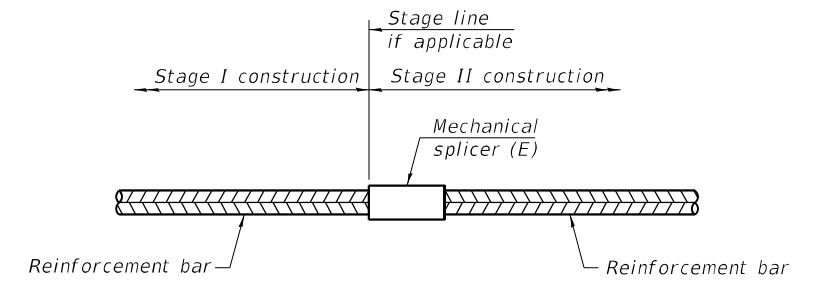

**STANDARD MECHANICAL SPLICER**

Location	Bar size	No. assemblies required

Location	Bar size	No. assemblies required	Minimum lap length
Deck Top	#5	412	3'-0"
Deck Bottom	#5	263	3'-6"
Abutment Diaphragm, Front Face	#6	8	See Diaphragm Bar Splicer Detail
Abutment Diaphragm, Back Face	#6	10	4'-0"
Abutment Diaphragm, Above PJF	#4	4	2'-5"
Abutment Backwall, Below PJF	#4	4	2'-7"
Approach Slab Top	#5	92	3'-4"
Approach Slab Bottom	#8	120	4'-9"
Approach Slab Footing	#5	80	3'-2"

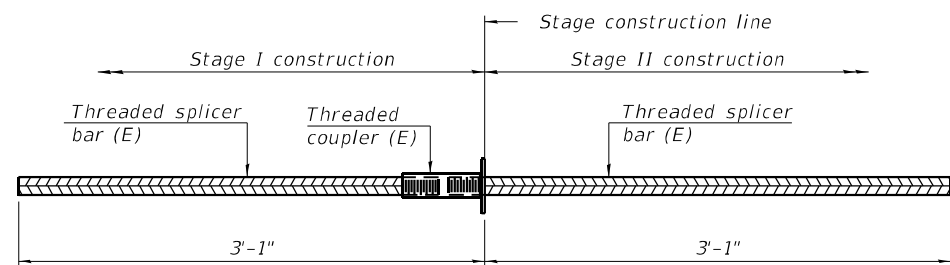

**DIAPHRAGM BAR SPLICER DETAIL**

(All components shall be provided from one supplier)

**Notes:**

Splicer bars shall be deformed with threaded ends and have a minimum 60 ksi yield strength.

All reinforcement shall be lapped and tied to the splicer bars.

Bar splicer assemblies shall be epoxy coated according to the requirements for reinforcement bars. See Section 508 of the Standard Specifications.

See approved list of bar splicer assemblies and mechanical splicers for alternatives.

MODEL: Default  
FILE NAME: I:\0.0.0.90\Projects\2021\121221\1C - IL 78 over FAI 74 & CH 18\4 CADD - DWG\4.4 - Struct\0720032-68D48-025-Bar Splicer Details.dgn



**TWM, INC.**  
www.twm-inc.com  
IL DESIGN FIRM LICENSE NO: 184-001220

USER NAME = cktovell  
DESIGNED - JBE  
CHECKED - CDK  
DRAWN - JBE  
CHECKED - CDK

REVISED -  
REVISED -  
REVISED -  
REVISED -

**STATE OF ILLINOIS  
DEPARTMENT OF TRANSPORTATION**

**BAR SPLICER ASSEMBLY AND MECHANICAL SPLICER DETAILS  
STRUCTURE NO. 072-0032**

SHEET 25 OF 25 SHEETS

F.A.I. RTE.	SECTION	COUNTY	TOTAL SHEETS	SHEET NO.
74	[(72-30;48-29)HB-1]BRR	PEORIA	115	54
CONTRACT NO. 68D48			ILLINOIS FED. AID PROJECT	

MODEL: P:\d48\IL 78 over FA1 74 & Ch 1B4 CADD - DWG\4.7 Tran\CAD\_Sheets\1\48\BDD48-shr-entire\barreous\_details-guardrail IL 78-0032.dwg  
 FILE NAME: P:\2021\1122\IL - 78 over FA1 74 & Ch 1B4 CADD - DWG\4.7 Tran\CAD\_Sheets\1\48\BDD48-shr-entire\barreous\_details-guardrail IL 78-0032.dwg

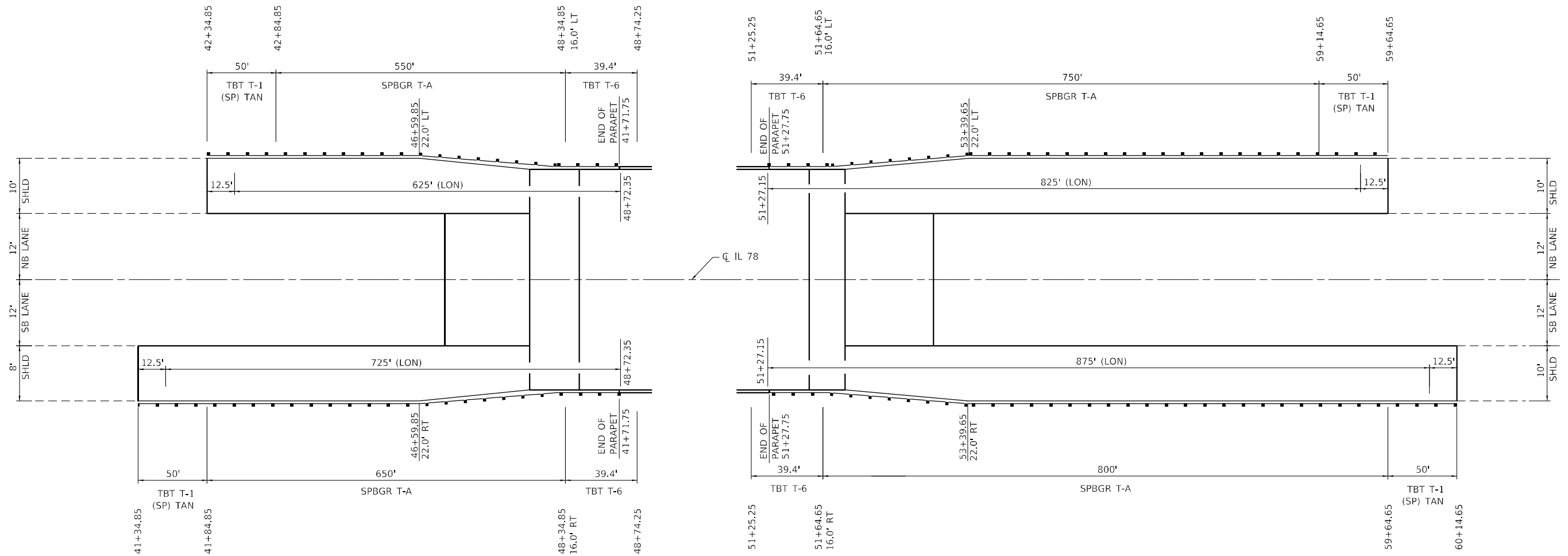

**GUARDRAIL LENGTH OF NEED (LON) DETAILS**  
**IL 78**

NOTE:

AT THE POINT WHERE THE GUARDRAIL MEETS FLARED GUARDRAIL, A 12.5 FT SECTION OF STEEL PLATE BEAM GUARDRAIL SHALL BE INSTALLED ON A SLIGHT CURVE BY ADJUSTING THE POST BACK A SMALL DISTANCE.



N.T.S.



**TWM, INC.**  
 WWW.TWM-INC.COM  
 IL DESIGN FIRM  
 LICENSE NO:  
 184-001220

USER NAME =	bbillhartz
DESIGNED -	
DRAWN -	
PLOT SCALE =	40,0000 * / in.
CHECKED -	
PLOT DATE =	10/4/2023
REVISÉD -	
DATE -	

STATE OF ILLINOIS  
 DEPARTMENT OF TRANSPORTATION

**GUARDRAIL LON**  
**IL 78 - S.N. 072-0032**

SCALE: N.T.S. SHEET 1 OF 1 SHEETS STA. TO STA.

F.A.I. RTE.	SECTION	COUNTY	TOTAL SHEETS	SHEET NO.
74	[(72-30;48-29)HB-1]BRR	PEORIA & KNOX	115	55
CONTRACT NO. 68D48				
ILLINOIS FED. AID PROJECT				





# SLOPE STEPS DETAIL

## TYPICAL CROSS-SECTION EMBANKMENT CONSTRUCTION ON SIDEHILL

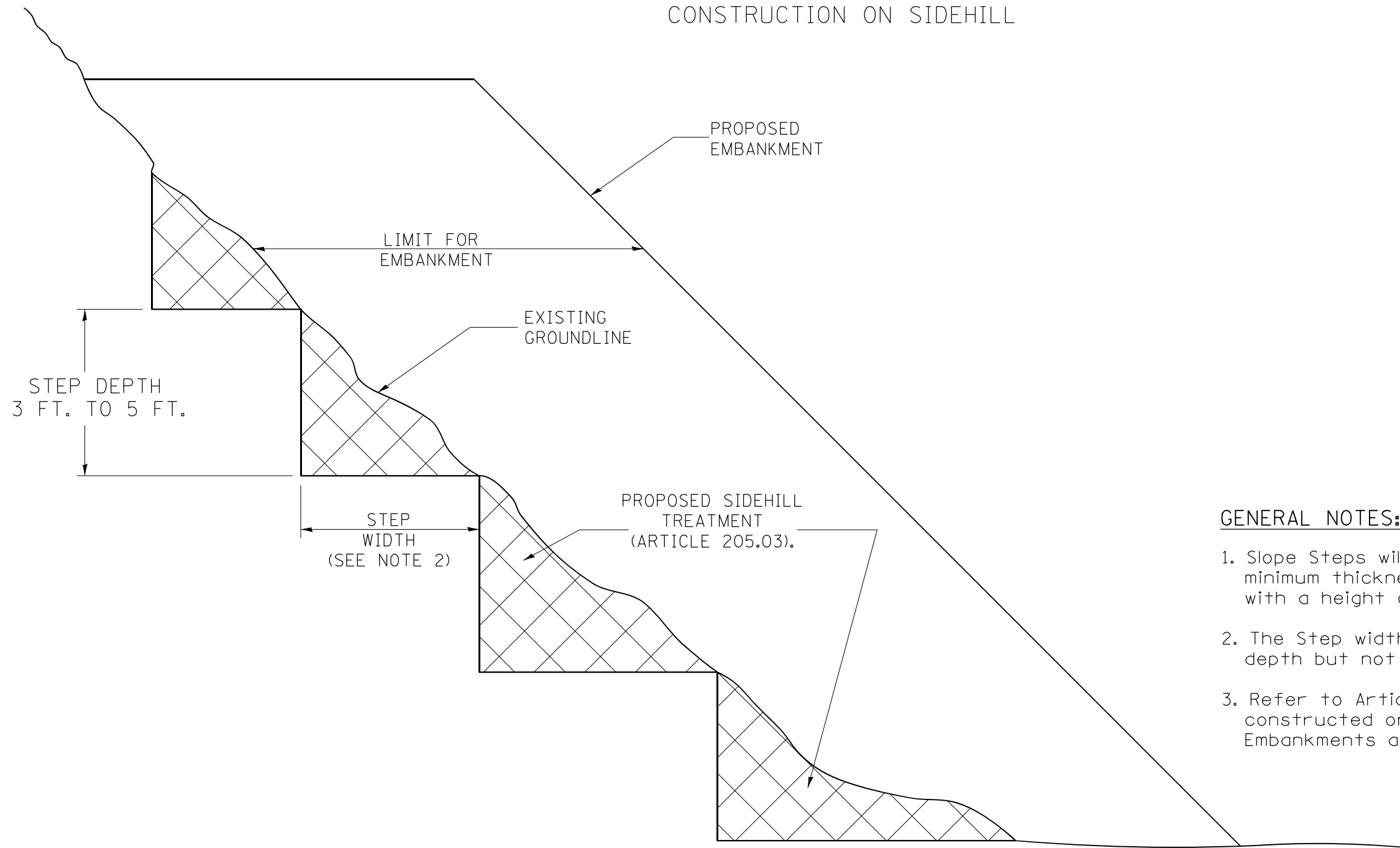

**GENERAL NOTES:**

1. Slope Steps will be required for all 12(300) minimum thickness "sliver fills" and on all fills with a height of 10 feet or greater.
2. The Step width shall be twice the Step depth but not less than 6 feet.
3. Refer to Article 205.03 for Embankment to be constructed on Hillside or Slopes, or if existing Embankments are to be widened.

**REPLACEMENT MATERIAL:**

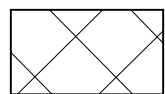

STANDARD EMBANKMENT  
(IN ACCORDANCE WITH  
205 OF THE STANDARD SPECIFICATION).

All dimensions are in inches (millimeters)  
unless otherwise noted.

MODEL: D:\p\h\... FILE NAME: P:\2023\1122\IC - IL 78 over FAI 74 & CH 1B4 CADD - DWG\4.7 FromCAD\_Sheets\1468D48.sht=shape\_steps\_detail\_78.dgn

**TWM**  
ENGINEERING  
GEOSPATIAL SERVICES

**TWM, INC.**  
WWW.TWM-INC.COM

IL DESIGN FIRM  
LICENSE NO:  
184-001220

USER NAME = bbillhartz	DESIGNED -	REVISED -
PLOT SCALE = 40,0000 * / in.	DRAWN -	REVISED -
PLOT DATE = 10/4/2023	CHECKED -	REVISED -
	DATE -	REVISED -

**STATE OF ILLINOIS  
DEPARTMENT OF TRANSPORTATION**

**SLOPE STEPS DETAIL  
IL 78**

SCALE: N.T.S. SHEET 1 OF 1 SHEETS STA. TO STA.

**DISTRICT 4 DETAIL NO. 205001**

F.A.I. RTE.	SECTION	COUNTY	TOTAL SHEETS	SHEET NO.
74	[(72-30;48-29)HB-1]BRR	PEORIA & KNOX	115	57
CONTRACT NO. 68D48				
ILLINOIS FED. AID PROJECT				

**HOT MIX ASPHALT SURFACE REMOVAL - BUTT JOINT**

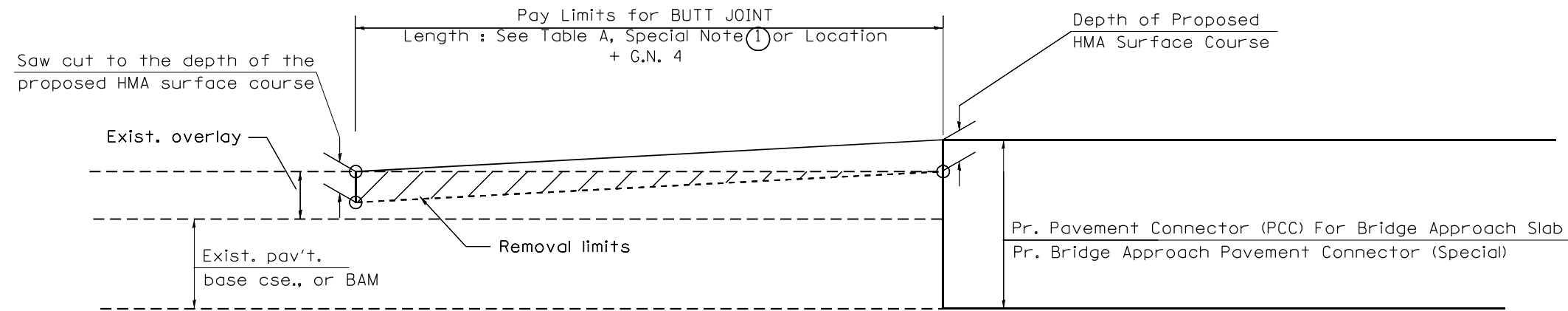

**CASE 1: TEMPORARY RAMP DETAIL**

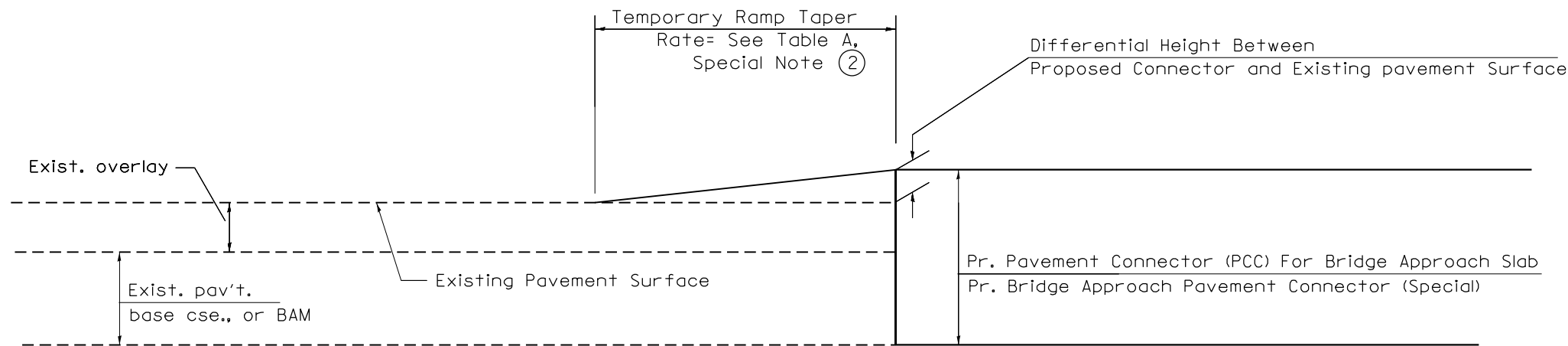

**CASE 2: TEMPORARY RAMP DETAIL**

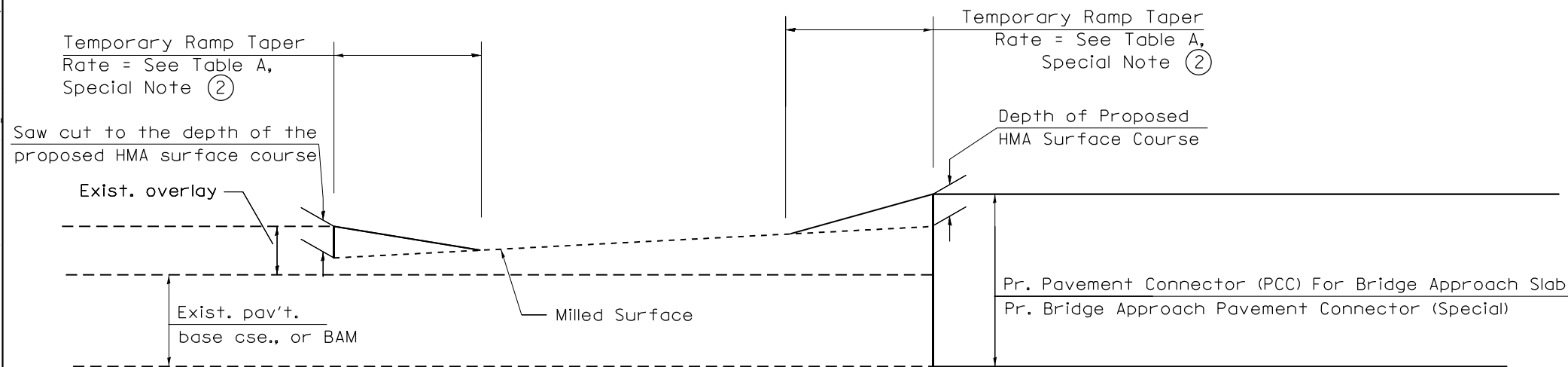

**TABLE A  
TAPER RATES**

SPECIAL NOTE NUMBER OR LOCATION	ELEMENT	IL 78
① SN 072-0032	BUTT JOINT TAPER RATE	1:360
②	TEMPORARY RAMP TAPER RATE	1:40

**GENERAL NOTES**

- The work shall be done in accordance with Article 406.08 and the Special Provision for Butt Joints.
- The pavement surface to be removed may be either bituminous or P.C. concrete. The work shall be performed in accordance with Article 440.04 and the Special Provisions for Butt Joints.
- The saw cut joints shall be primed just prior to the placing of bituminous material. The work will be in accordance with the applicable portions of Article 406.05.
- The length of butt joint is based on the taper rate times change in cold milling depth within the butt joint pay limits, unless otherwise indicated.
- Temporary ramps are paid for separately and not included in the cost of the butt joints.

All dimensions are in inches (millimeters) unless otherwise noted.

**DISTRICT 4 DETAIL NO. 406101 MODIFIED**

F.A.I. RTE.	SECTION	COUNTY	TOTAL SHEETS	SHEET NO.
74	[(72-30;48-29)HB-1]BRR	PEORIA & KNOX	115	58
			CONTRACT NO. 68D48	
			ILLINOIS FED. AID PROJECT	

**STATE OF ILLINOIS  
DEPARTMENT OF TRANSPORTATION**

**BUTT JOINT AND TEMPORARY RAMP DETAILS  
IL 78**

SCALE: N.T.S. SHEET 1 OF 1 SHEETS STA. TO STA.

MODEL: D:\pfa\11... FILE NAME: P202011211221C - IL 78 over PA 74 & CH 1B4 CADD - DWG\47 TranCAD\_Sheets\468D48-ah-but-but-joint\_standard.dgn



USER NAME = bbillhartz	DESIGNED -	REVISD -
PLOT SCALE = 100,0000' / in.	DRAWN -	REVISD -
PLOT DATE = 10/4/2023	CHECKED -	REVISD -
	DATE -	REVISD -



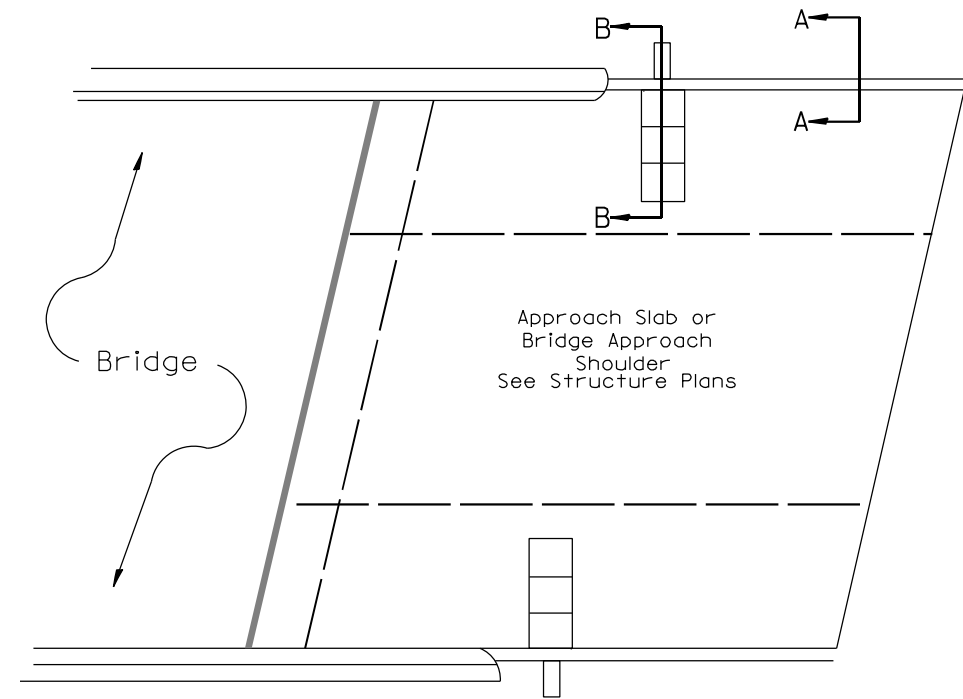
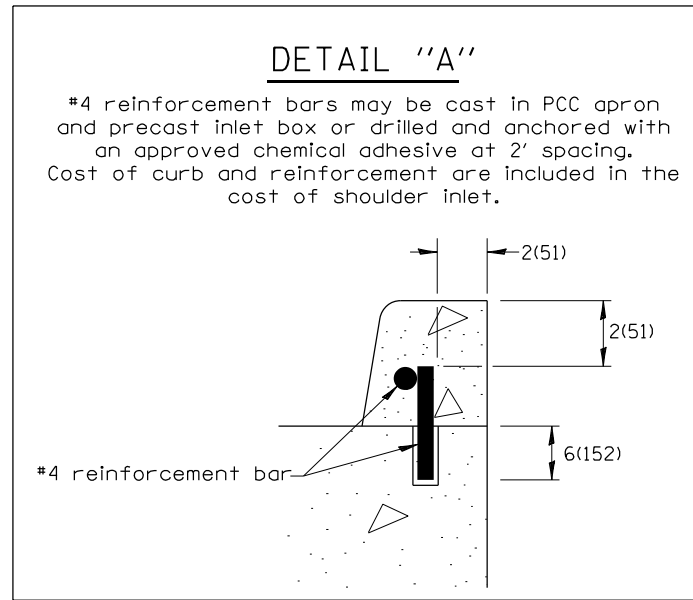

**PLAN VIEW**  
**APPROACH SLAB OR SHOULDER PLACEMENT**

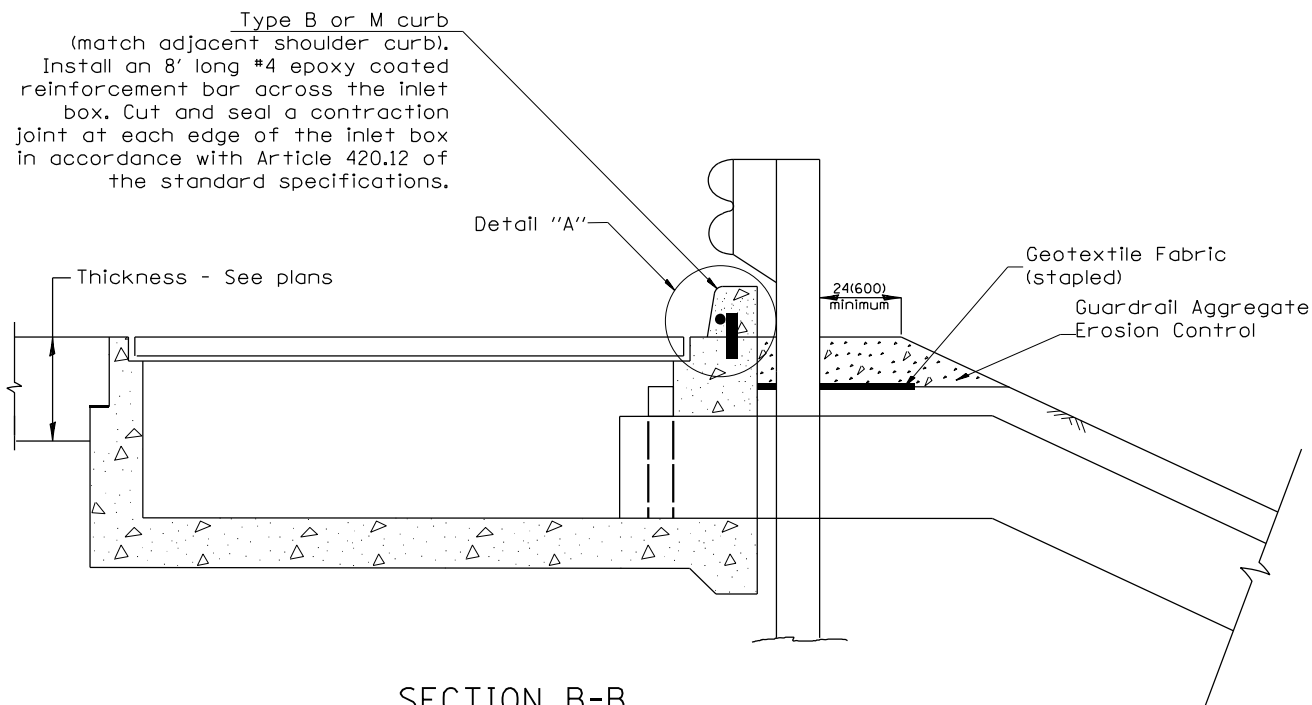

**SECTION B-B**  
**TYPICAL SECTION AT INLETS**  
**TYPE E, F & G (HIGHWAY STANDARD 610001)**

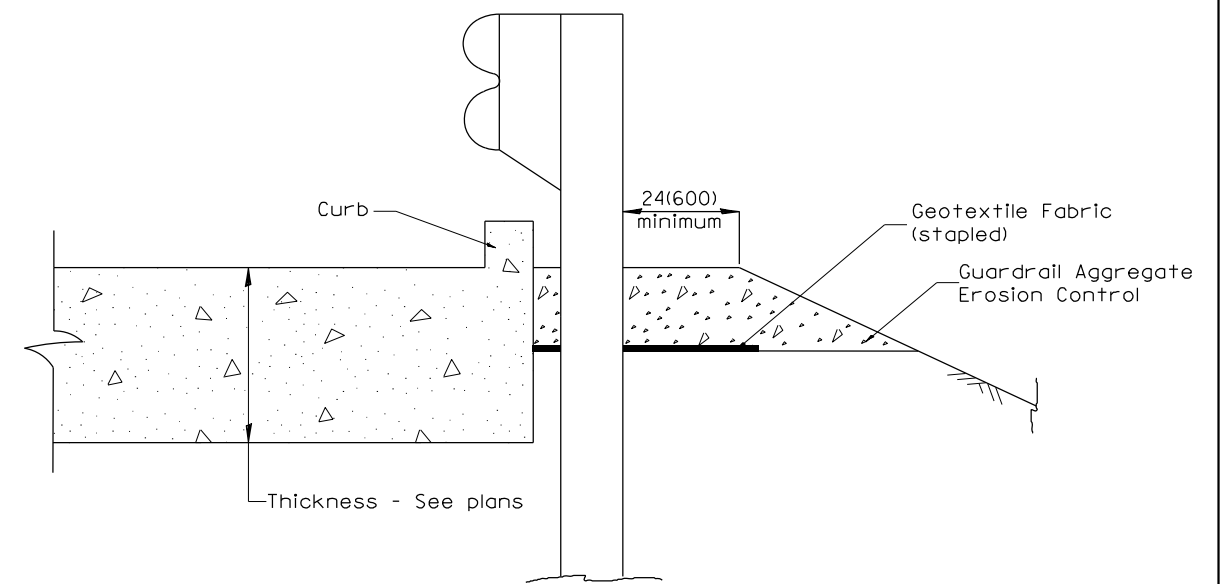

**SECTION A-A**  
**TYPICAL SECTION WITH BRIDGE APPROACH CURB**

All dimensions are in inches (millimeters) unless otherwise noted.

MODEL: D:\p\h\... FILE NAME: P:\2021\112121\NC - IL 78 over FAI 74 & CH 1B4 CADD - DWG\4.7 TranCAD\_Sheets\1468D48-shr-guardrail\_erosion\_control\_treatments\_standard.dwg



**TWM, INC.**  
www.twm-inc.com  
IL DESIGN FIRM LICENSE NO: 184-001220

USER NAME = bbillhartz	DESIGNED -	REVISED -
PLOT SCALE = 100,0000' / in.	DRAWN -	REVISED -
PLOT DATE = 10/4/2023	CHECKED -	REVISED -
	DATE -	REVISED -

**STATE OF ILLINOIS**  
**DEPARTMENT OF TRANSPORTATION**

**GUARDRAIL EROSION CONTROL TREATMENTS**  
**IL 78**

SCALE: N.T.S. SHEET 2 OF 2 SHEETS STA. TO STA.

DISTRICT 4 DETAIL NO. 630101				
F.A.I. RTE.	SECTION	COUNTY	TOTAL SHEETS	SHEET NO.
74	[(72-30;48-29)HB-1]BRR	PEORIA & KNOX	115	60
CONTRACT NO. 68D48				
ILLINOIS FED. AID PROJECT				

**PERMANENT SURVEY TIES**

- Permanent Survey Tie
- Section Corner, 1/4 Corner, or other land corner.

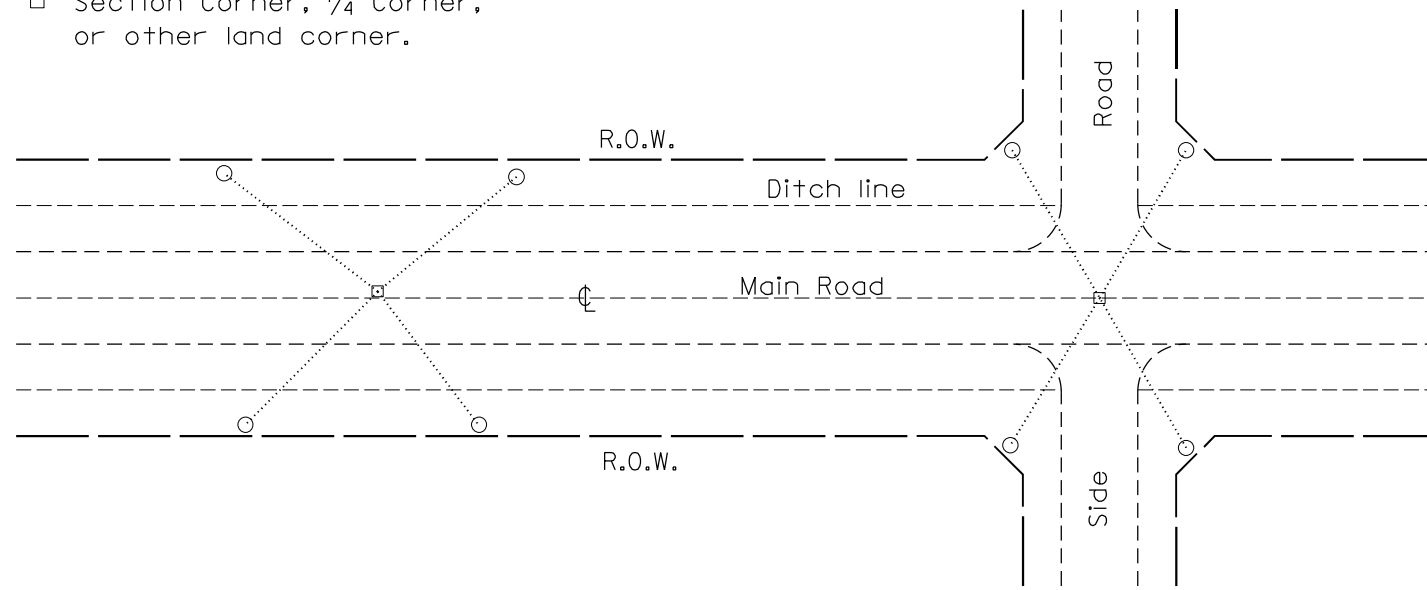

**TYPICAL APPLICATION**

**GENERAL NOTES**

1. The marker shall be cast in place of Class SI Concrete.
2. Tie marker shall be installed after the final seeding has been completed unless otherwise specified by the Engineer.
3. The tie distances to the section corner shall be measured and recorded by the surveyor setting the PSM. All ties shall be turned over to the IDOT Chief of Surveys or Chief of Plats after recordation.
4. All documentation shall be performed by a PLS
5. The metal tablet used on permanent survey markers shall be made of bronze.

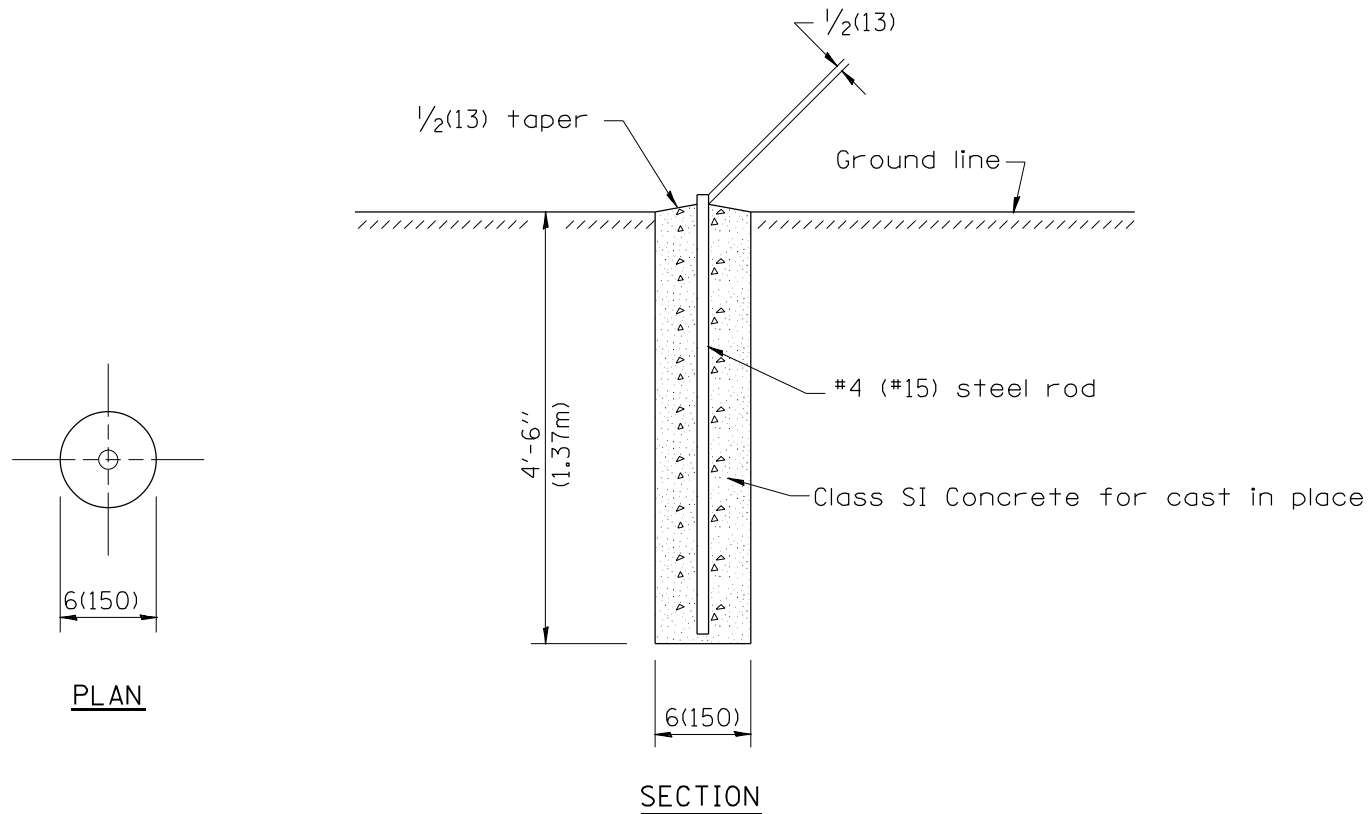

**PERMANENT SURVEY MARKERS**

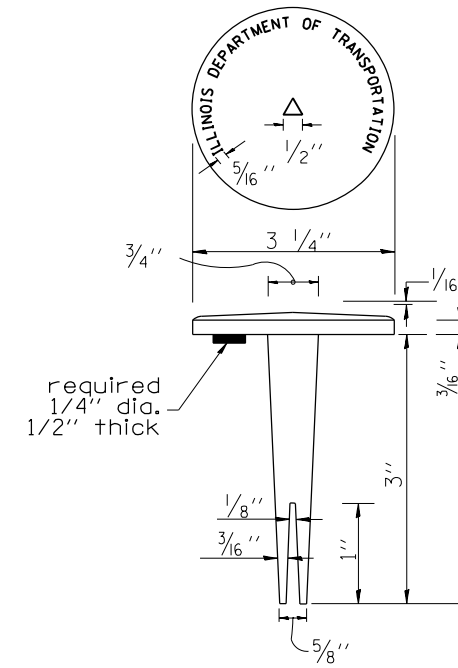

**BRASS TABLET**

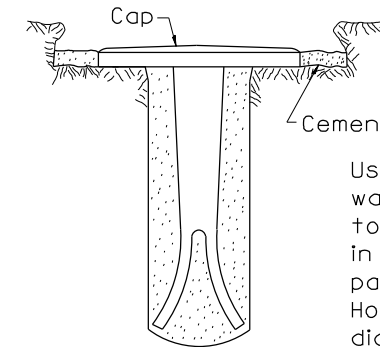

Tablet constructed in rock ledge or concrete.

**TYPE I**

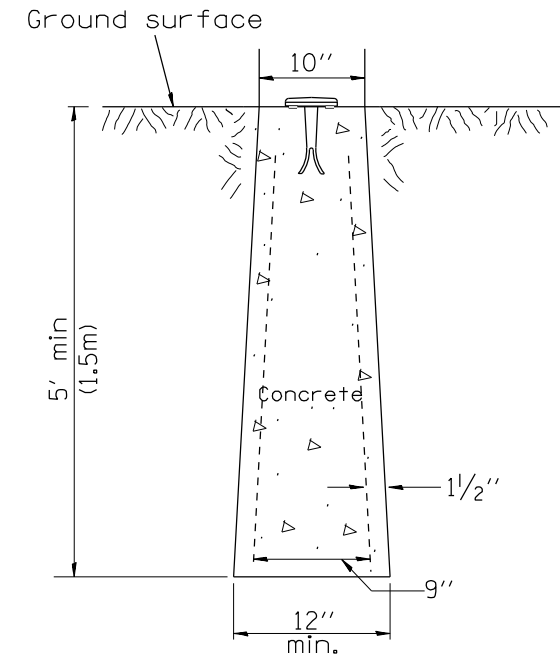

**TYPE II  
CAST-IN-PLACE MARKER**

**GENERAL NOTES**

1. All type II markers shall be cast in place, and precast markers will not be allowed.
2. Two permanent magnets, each having a diameter of 3/4 (19) and a thickness of 1/4 (6), or equivalent, shall be attached to the underside of the tablet with an approved epoxy bonding agent.
3. The location of the markers shall be in accordance with the plans in general, the markers will be placed at the P.T.'s, P.C.'s, and P.I.'s located within the R.O.W. of horizontal curves and spaces along the tangents in a way that a minimum of two markers are always inter-visible, and not to exceed 1000' (300m).
4. The markers shall be placed under the direction of the Engineer and shall be installed in a workmanlike manner in order that there will be no further settlement or horizontal shifting. The monuments shall be placed in a way that the survey point will fall within the portion of the plaque provided for that purpose.
5. The project designation, the centerline station, the survey point, and the elevation shall be permanently marked by the use of metal dies after marker has been installed.

All dimensions are in inches (millimeters) unless otherwise noted.

**DISTRICT 4 DETAIL NO. 667101**

**STATE OF ILLINOIS  
DEPARTMENT OF TRANSPORTATION**

**PERMANENT SURVEY TIE &  
PERMANENT SURVEY MARKERS TY.I - TY.II - IL 78**

SCALE: N.T.S. SHEET 1 OF 1 SHEETS STA. TO STA.

F.A.I. RTE.	SECTION	COUNTY	TOTAL SHEETS	SHEET NO.
74	[(72-30;48-29)HB-1]BRR	PEORIA & KNOX	115	60A
CONTRACT NO. 68D48				
ILLINOIS FED. AID PROJECT				

MODEL: D:\p\h\h... FILE NAME: P:\2021\112121\NC - IL 78 over FAI 74 & CH 1B4 CADD - DWG\47 TranCAD\_Sheets\1468D48.dwg-Permanent Survey Marker Standard-IL 78.dwg

**TWM**  
ENGINEERING  
GEOSPATIAL SERVICES

**TWM, INC.**  
www.twm-inc.com  
IL DESIGN FIRM  
LICENSE NO:  
184-001220

USER NAME = bbillhartz	DESIGNED -	REVISED -
PLOT SCALE = 40,0000 * / in.	DRAWN -	REVISED -
PLOT DATE = 10/16/2023	CHECKED -	REVISED -
	DATE -	REVISED -

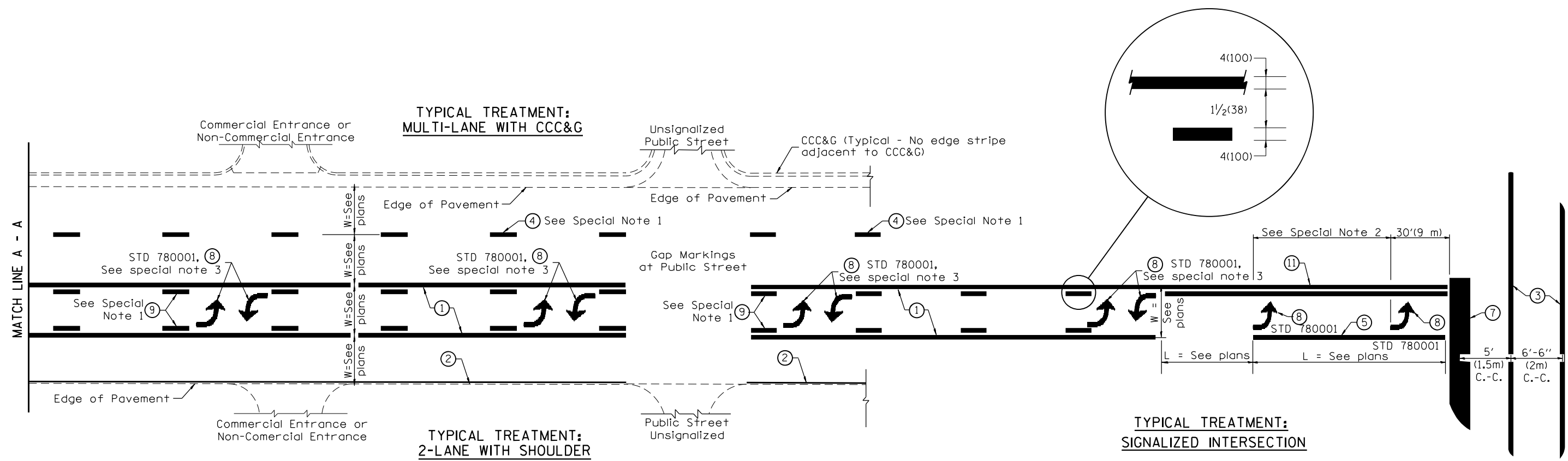

**FLUSH PAVED MEDIAN: TWO-WAY LEFT TURN LANE WITH ONE-WAY LEFT TURN LANE AT SIGNALIZED INTERSECTION**

**TYPICAL PAVEMENT MARKING LEGEND**

(Note: This is a District Standard Legend. Some elements may not apply to specific project.)

- ① 4(100) Solid (Yellow)
- ② 4(100) Solid (White)
- ③ 2-6(150) Crosswalk @ 6'-6" (2m)min C.-C. (White)  
2-8(200) Crosswalk @ 6'-6" (2m)min C.-C. (White) (When traffic signals are present.)
- ④ 6(150) Skip-Dash (White) (See Special Note 1)
- ⑤ 8(200) Solid (White)
- ⑥ 12(300) Diagonal (White) (Item ⑥ is shown on Std. 780001)
- ⑦ 24(600) Stop Bar (White)
- ⑧ Letters & Arrows (See Std. 780001 and Special Notes 2 & 3)
- ⑨ 4(100) Skip-Dash (Yellow) (See Special Note 1)
- ⑩ 12(300) Diagonal (Yellow) (See Table A) 45°
- ⑪ 4(100) Double Solid (Yellow) 11(280) C.-C. See Table A

**SPECIAL NOTES**

1. Skip-Dash markings will be centered between both ends of city blocks and shall be placed in alignment transversely across the pavement.
2. The following shall apply to arrows located in one-way left turn lanes:
  - A. A minimum of two (2) arrows is required.
  - B. The maximum spacing between arrows is 80' (24 m).
  - C. Arrows shall be evenly spaced if three (3) or more are required.
3. The following shall apply to arrow pairs located in two-way left turn lanes:
  - A. A minimum of two (2) arrow pairs is required.
  - B. The maximum spacing between arrow pairs is 200' (61 m).
  - C. Arrow pairs shall be evenly spaced if three (3) or more are required.
  - D. The spacing between Bi Directional Left Turn Arrows is 33' (10 m).

**GENERAL NOTES**

1. Refer to State Standard 780001 for additional Pavement Markings including letters & arrows.
2. See Plans for Pavement Markings adjacent to curbed islands and medians, and through lane reductions.
3. Refer to Article 780.13 for letter, number and symbol areas (sq. ft.)
4. Areas are grooved 1" beyond each edge for the following symbols:  
Through Arrow= 14.8 sq. ft.  
Large Left or Right Arrow= 21.9 sq. ft.  
2 Arrow Combination Left (or Right) and Through= 34.9 sq. ft.  
Wrong Way Arrow= 29.5 sq. ft.  
Railroad Crossing Symbol= 69.8 sq. ft.  
(For further information, refer to BDE Special Provision: Grooving for Recessed Pavement Markings)

All dimensions are in inches (millimeters) unless otherwise noted.

MODEL Path: \\... FILE NAME: P:\2021\1122\IC - IL 78 over FAI 74 & Ch 1B4 CADD - DWG\4.7 TranCAD\_Sheets\1848018-entr-typical pavement markings\_standard.dgn



**TWM, INC.**  
www.twm-inc.com  
IL DESIGN FIRM LICENSE NO: 184-001220  
USER NAME = bbillhartz  
PLOT SCALE = 100,000' / in.  
PLOT DATE = 10/4/2023

DESIGNED -	REVISED -
DRAWN -	REVISED -
CHECKED -	REVISED -
DATE -	REVISED -

**STATE OF ILLINOIS  
DEPARTMENT OF TRANSPORTATION**

**TYPICAL PAVEMENT MARKINGS  
IL 78**

SCALE: SHEET 1 OF 2 SHEETS STA. TO STA.

DISTRICT 4 DETAIL NO. 780001				
F.A.I. RTE.	SECTION	COUNTY	TOTAL SHEETS	SHEET NO.
74	[(72-30;48-29)HB-1]BRR	PEORIA & KNOX	115	61
CONTRACT NO. 68D48				
ILLINOIS FED. AID PROJECT				



FINAL SURVEY NO.	SURVEYED	BY	DATE
NOTE BOOK	PLOTTED		
AREAS CHECKED	TEMPLATE		
AREAS CHECKED	AREAS		

ORIGINAL SURVEY NO.	SURVEYED	BY	DATE
NOTE BOOK	PLOTTED		
AREAS CHECKED	TEMPLATE		
AREAS CHECKED	AREAS		

MODEL: Definit  
 FILE NAME: P:\2021\1212\116 - IL 78 over FAI 74 & Ch 184 CADD - DWG\67 TrmCAD\_Sheets\68D48-xss-hh\IL78.dwg

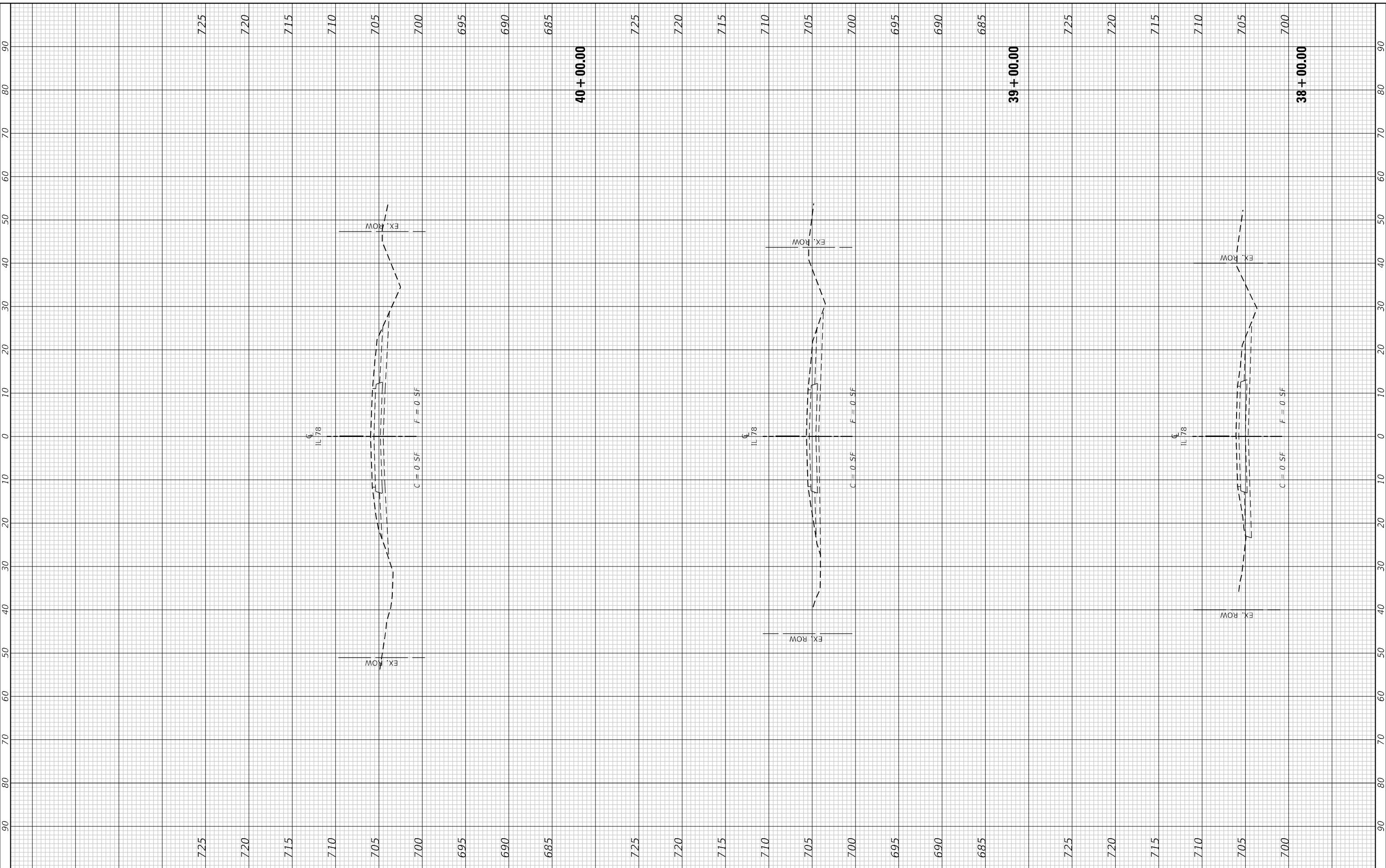

**TWM** ENGINEERING GEOSPATIAL SERVICES  
 TWM, INC. www.twm-inc.com  
 IL DESIGN FIRM LICENSE NO: 184-001220

USER NAME =	bbillhartz	DESIGNED -	REvised -
PLOT SCALE =	20,0000 * / in.	DRAWN -	REvised -
PLOT DATE =	10/4/2023	CHECKED -	REvised -
		DATE -	REvised -

DESIGNED -	REvised -
DRAWN -	REvised -
CHECKED -	REvised -
DATE -	REvised -

**STATE OF ILLINOIS  
 DEPARTMENT OF TRANSPORTATION**

**CROSS SECTIONS  
 IL 78**

SCALE: 1"=10'    SHEET 1 OF 9 SHEETS    STA. 38+00.00 TO STA. 40+00.00

F.A.I. RTE.	SECTION	COUNTY	TOTAL SHEETS	SHEET NO.
74	[(72-30;48-29)HB-1]BRR	PEORIA & KNOX	115	63
CONTRACT NO. 68D48			ILLINOIS   FED. AID PROJECT	



FINAL SURVEY NO.	SURVEYED	BY	DATE
NOTE BOOK	PLOTTED		
AREAS CHECKED	TEMPLATE		
AREAS CHECKED	AREAS		
AREAS CHECKED	AREAS		

ORIGINAL SURVEY NO.	SURVEYED	BY	DATE
NOTE BOOK	PLOTTED		
AREAS CHECKED	TEMPLATE		
AREAS CHECKED	AREAS		
AREAS CHECKED	AREAS		

MODEL: Definit  
 FILE NAME: P:\2021\1212\11C - IL 78 over FAI 74 & Ch 184 CADD - DWG\67 - Trm\CAD\_Sheets\68D48-ss-hh-IL78.dwg

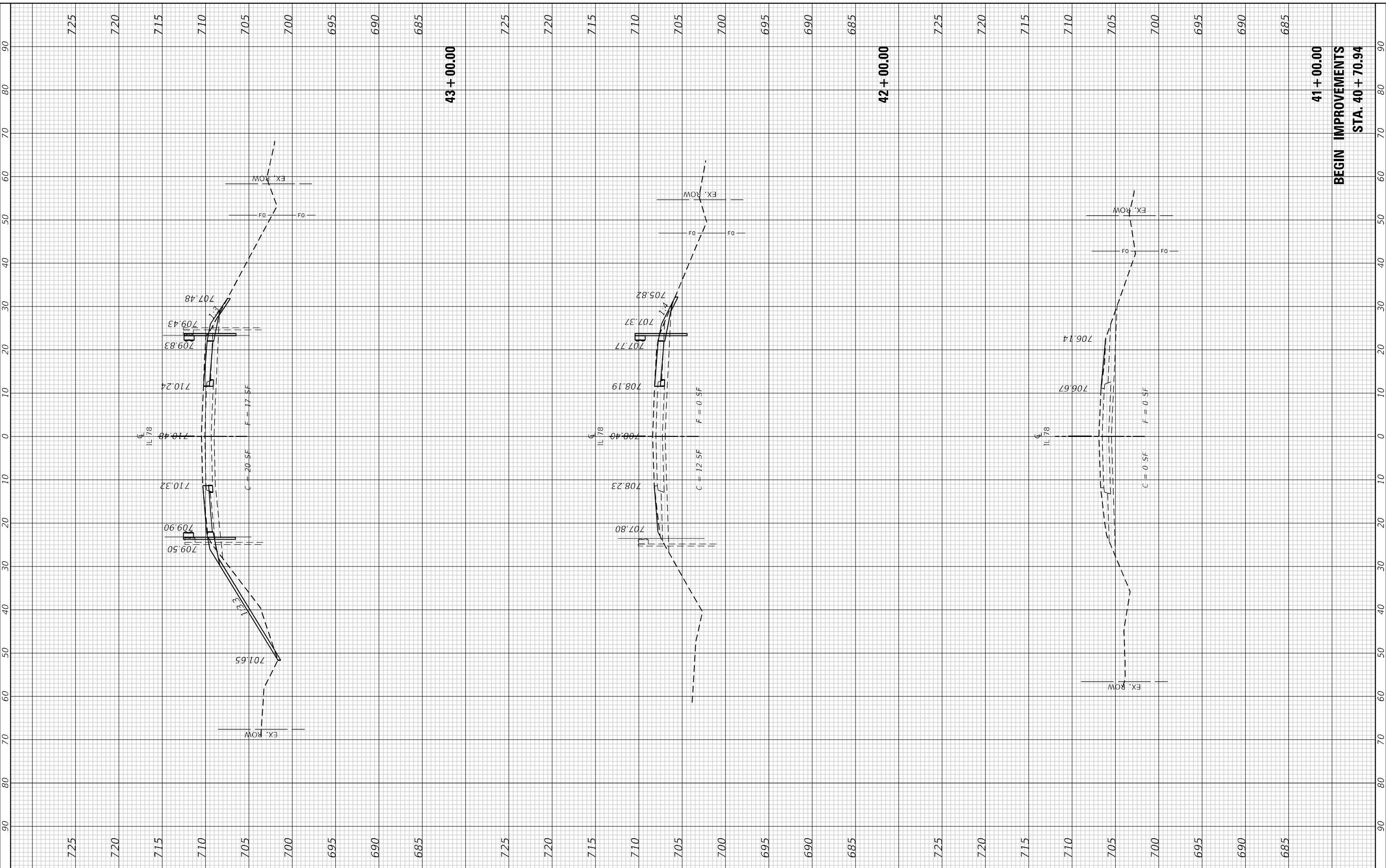

**TWM**  
 ENGINEERING  
 GEOSPATIAL SERVICES

**TWM, INC.**  
 www.twm-inc.com  
 IL DESIGN FIRM  
 LICENSE NO:  
 184-001220

USER NAME =	bbillhartz
DESIGNED -	
DRAWN -	
CHECKED -	
DATE -	
PLOT SCALE =	20.0000' / in.
PLOT DATE =	10/4/2023

DESIGNED -	
DRAWN -	
CHECKED -	
DATE -	
REVISED -	
REVISED -	
REVISED -	
REVISED -	

**STATE OF ILLINOIS  
 DEPARTMENT OF TRANSPORTATION**

**CROSS SECTIONS  
 IL 78**

SCALE: 1"=10'    SHEET 2 OF 9 SHEETS    STA. 41+00.00 TO STA. 43+00.00

F.A.I. RTE.	SECTION	COUNTY	TOTAL SHEETS	SHEET NO.
74	[(72-30;48-29)HB-1]BRR	PEORIA & KNOX	115	64
CONTRACT NO. 68D48				
ILLINOIS		FED. AID PROJECT		

FINAL SURVEY NO.	SURVEYED	BY	DATE
NOTE BOOK	PLOTTED		
AREAS CHECKED	TEMPLATE		
	AREAS		
	CHECKED		

ORIGINAL SURVEY NO.	SURVEYED	BY	DATE
NOTE BOOK	PLOTTED		
AREAS CHECKED	TEMPLATE		
	AREAS		
	CHECKED		

MODEL: Definit  
FILE NAME: P:\2021\12\12\116 - IL 78 over FAI 74 & Ch 184 CADD - DWG\67\_TramCAD\_Sheets\68D48-ss-hh\IL78.dwg

**TWM**  
ENGINEERING  
GEOSPATIAL SERVICES

**TWM, INC.**  
www.twm-inc.com  
IL DESIGN FIRM  
LICENSE NO:  
184-001220

USER NAME =	bbillhartz
DESIGNED -	
DRAWN -	
CHECKED -	
DATE -	
PLOT SCALE =	20.0000' / in.
PLOT DATE =	10/4/2023

DESIGNED -	
DRAWN -	
CHECKED -	
DATE -	

REVISED -	
REVISED -	
REVISED -	
REVISED -	

**STATE OF ILLINOIS  
DEPARTMENT OF TRANSPORTATION**

**CROSS SECTIONS  
IL 78**

SCALE: 1"=10'      SHEET 3      OF 9      SHEETS      STA. 44+00.00      TO STA. 46+00.00

F.A.I. RTE.	SECTION	COUNTY	TOTAL SHEETS	SHEET NO.
74	[(72-30;48-29)HB-1]BRR	PEORIA & KNOX	115	65
CONTRACT NO. 68D48				
ILLINOIS		FED. AID PROJECT		

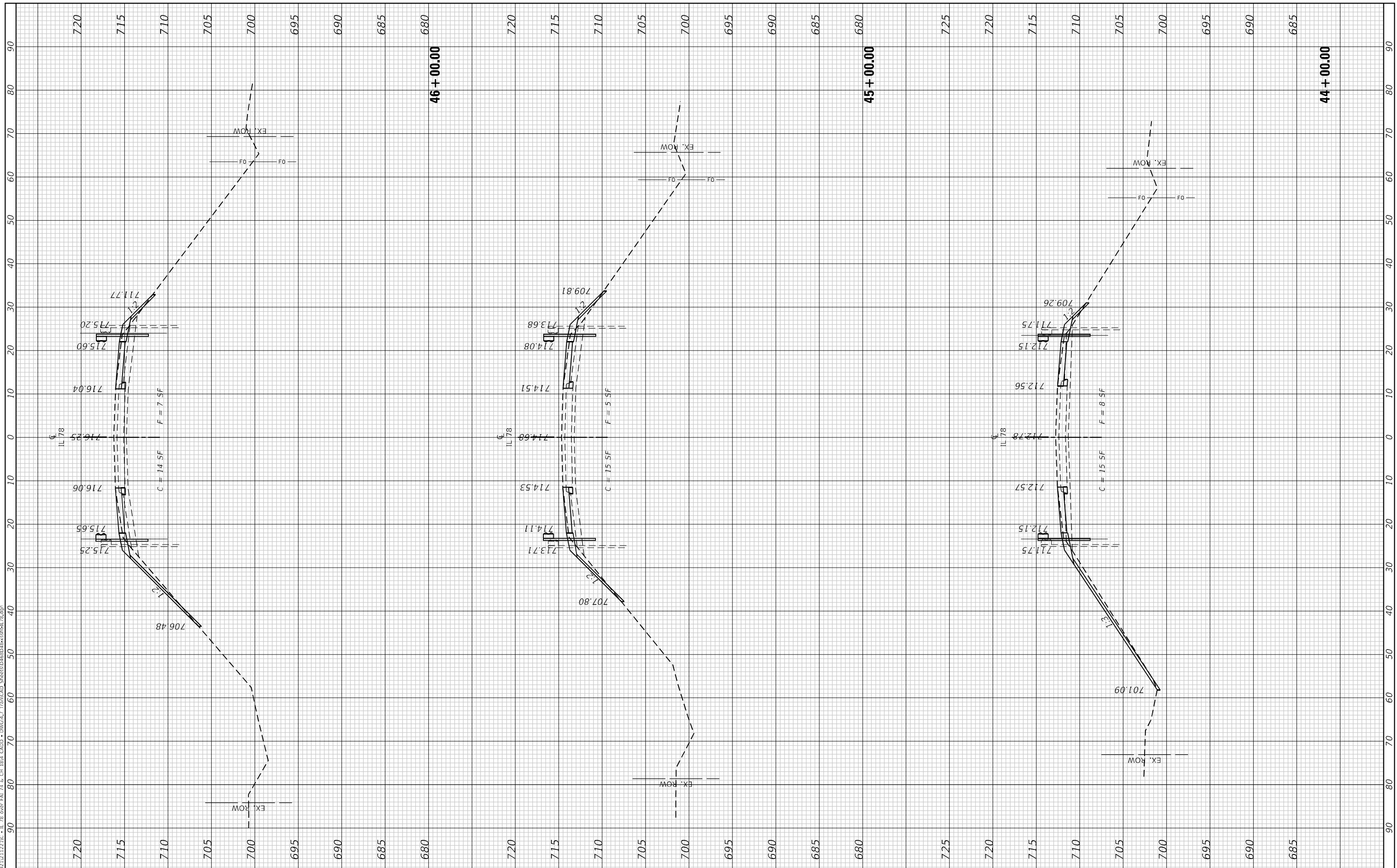

FINAL SURVEY NO.	SURVEYED	BY	DATE
NOTE BOOK	PLOTTED		
AREAS CHECKED	TEMPLATE		
	AREAS		
	CHECKED		

ORIGINAL SURVEY NO.	SURVEYED	BY	DATE
NOTE BOOK	PLOTTED		
AREAS CHECKED	TEMPLATE		
	AREAS		
	CHECKED		

MODEL: Definit  
FILE NAME: P:\2021\1212\116 - IL 78 over FAI 74 & Ch 184 CADD - DWG\67 Trm\CAD\_Sheets\48D48-ss-shh\78.dwg

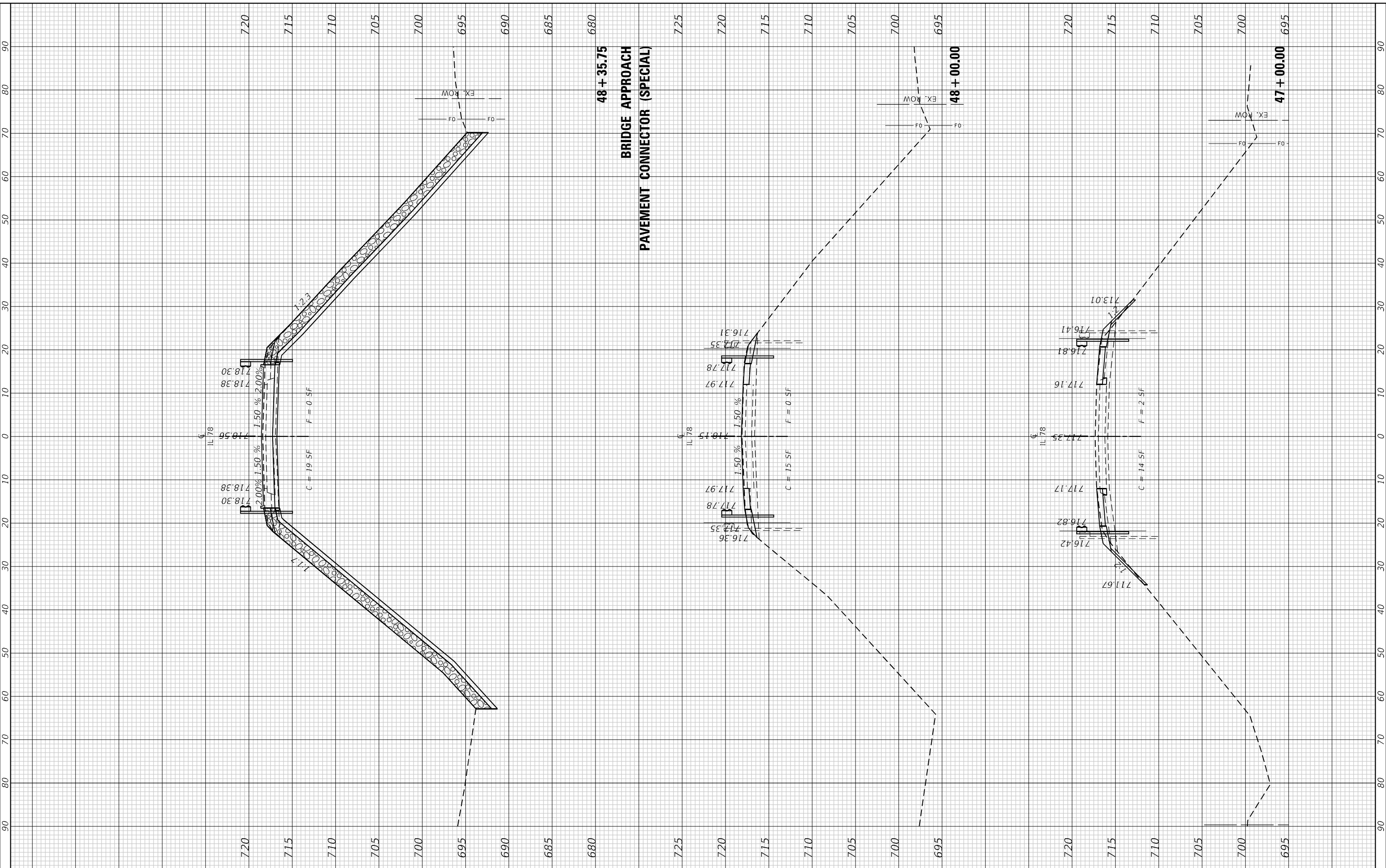

**TWM**  
ENGINEERING  
GEOSPATIAL SERVICES

**TWM, INC.**  
www.twm-inc.com  
IL DESIGN FIRM  
LICENSE NO:  
184-001220

USER NAME =	bbillhartz
PLOT SCALE =	20.0000' / in.
PLOT DATE =	10/4/2023

DESIGNED -	
DRAWN -	
CHECKED -	
DATE -	

REVISED -	
REVISED -	
REVISED -	
REVISED -	

STATE OF ILLINOIS  
DEPARTMENT OF TRANSPORTATION

CROSS SECTIONS			
IL 78			
SCALE: 1"=10'	SHEET 4	OF 9 SHEETS	STA. 47+00.00 TO STA. 48+35.75

F.A.I. RTE.	SECTION	COUNTY	TOTAL SHEETS	SHEET NO.
74	[(72-30;48-29)HB-1]BRR	PEORIA & KNOX	115	66
CONTRACT NO. 68D48				
ILLINOIS		FED. AID PROJECT		

FINAL SURVEY NO.	SHIPPED	DATE
NOTE BOOK	PLOTTED	
AREAS CHECKED	TEMPLATE	
	AREAS	
	CHECKED	

ORIGINAL SURVEY NO.	SURVEYED	DATE
	PLOTTED	
	TEMPLATE	
	AREAS	
	CHECKED	

MODEL: Definit  
 FILE NAME: P:\2021\12\1221\IL 78 over FAI 74 & Ch 184 CADD - DWG\G17 Trm\CAD\_Sheets\48+56.75\IL78.dwg

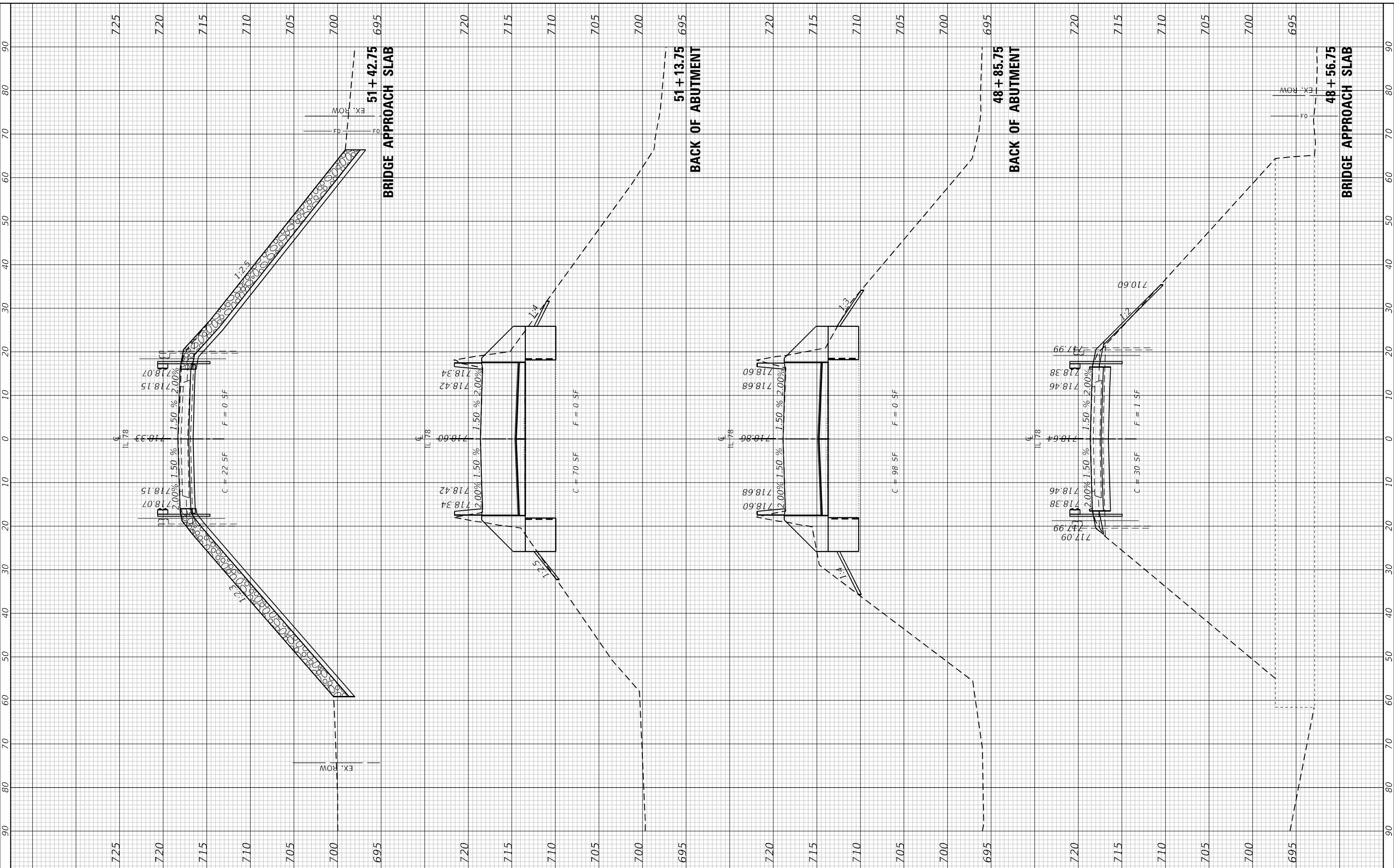

**TWM**  
 ENGINEERING  
 GEOSPATIAL SERVICES

**TWM, INC.**  
 WWW.TWM-INC.COM  
 IL DESIGN FIRM  
 LICENSE NO:  
 184-001220

USER NAME	= bbillhartz
DESIGNED	-
DRAWN	-
CHECKED	-
DATE	-
PLOT SCALE	= 20.0000' / in.
PLOT DATE	= 10/4/2023

REVISION	-
REVISION	-
REVISION	-
REVISION	-

**STATE OF ILLINOIS  
 DEPARTMENT OF TRANSPORTATION**

**CROSS SECTIONS  
 IL 78**

SCALE: 1"=10'    SHEET 5    OF 9    SHEETS    STA. 48+56.75    TO STA. 51+42.75

F.A.I. RTE.	SECTION	COUNTY	TOTAL SHEETS	SHEET NO.
74	[(72-30;48-29)HB-1]BRR	PEORIA & KNOX	115	67
CONTRACT NO. 68D48				
ILLINOIS		FED. AID PROJECT		

FINAL SURVEY NO.	SURVEYED	BY	DATE
NOTE BOOK	PLOTTED		
AREAS CHECKED	TEMPLATE		
AREAS CHECKED	AREAS		
	AREAS CHECKED		

ORIGINAL SURVEY NO.	SURVEYED	BY	DATE
NOTE BOOK	PLOTTED		
AREAS CHECKED	TEMPLATE		
AREAS CHECKED	AREAS		
AREAS CHECKED	AREAS CHECKED		

MODEL: Definit  
 FILE NAME: P:\2021\12\12\116 - IL 78 over FAI 74 & Ch 184 CADD - DWG\67\_TrimCAD\_Sheets\68D48-ss-shh\IL78.dwg

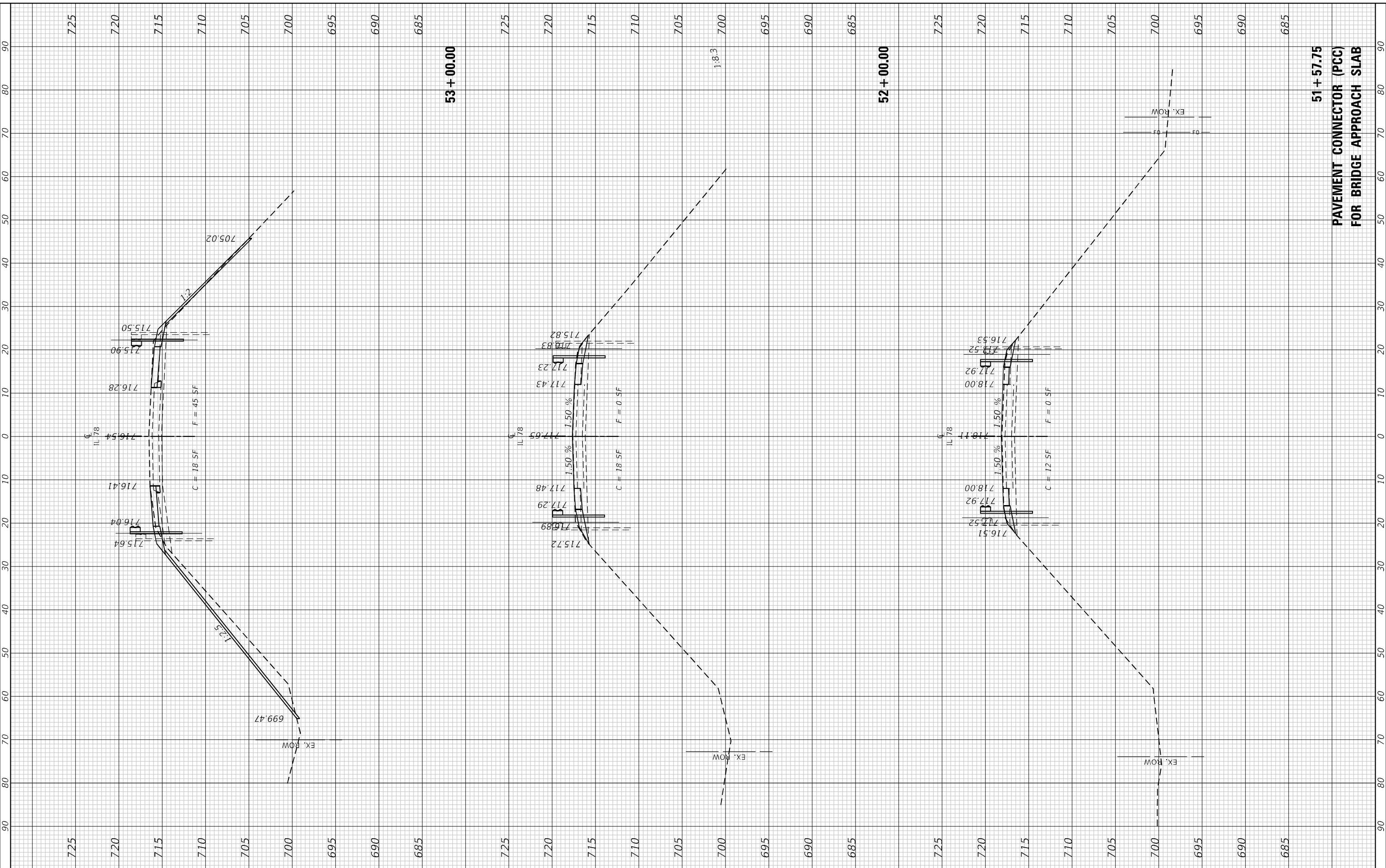

	USER NAME = bbillhartz	DESIGNED -	REVISED -	<b>STATE OF ILLINOIS</b> <b>DEPARTMENT OF TRANSPORTATION</b>	<b>CROSS SECTIONS</b> <b>IL 78</b>	F.A.I. RTE. 74	SECTION [(72-30;48-29)HB-1]BRR	COUNTY PEORIA & KNOX	TOTAL SHEETS 115	SHEET NO. 68
	PLOT SCALE = 20.0000' / in.	CHECKED -	REVISED -			SCALE: 1"=10'	SHEET 6 OF 9 SHEETS	TO STA. 51+57.75 TO STA. 53+00.00	CONTRACT NO. 68D48	
IL DESIGN FIRM LICENSE NO: 184-001220	PLOT DATE = 10/4/2023	DATE -	REVISED -							

FINAL SURVEY NO.	SURVEYED	BY	DATE
NOTE BOOK NO.	PLOTTED		
AREAS CHECKED	TEMPLATE		
	AREAS CHECKED		

ORIGINAL SURVEY NO.	SURVEYED	BY	DATE
	PLOTTED		
	TEMPLATE		
	AREAS CHECKED		

MODEL: Definit  
FILE NAME: P:\2021\12\12\116 - IL 78 over FAI 74 & Ch 184 CADD - DWG\67\_TranCAD\_Sheets\68D48-ss-shh\78.dwg

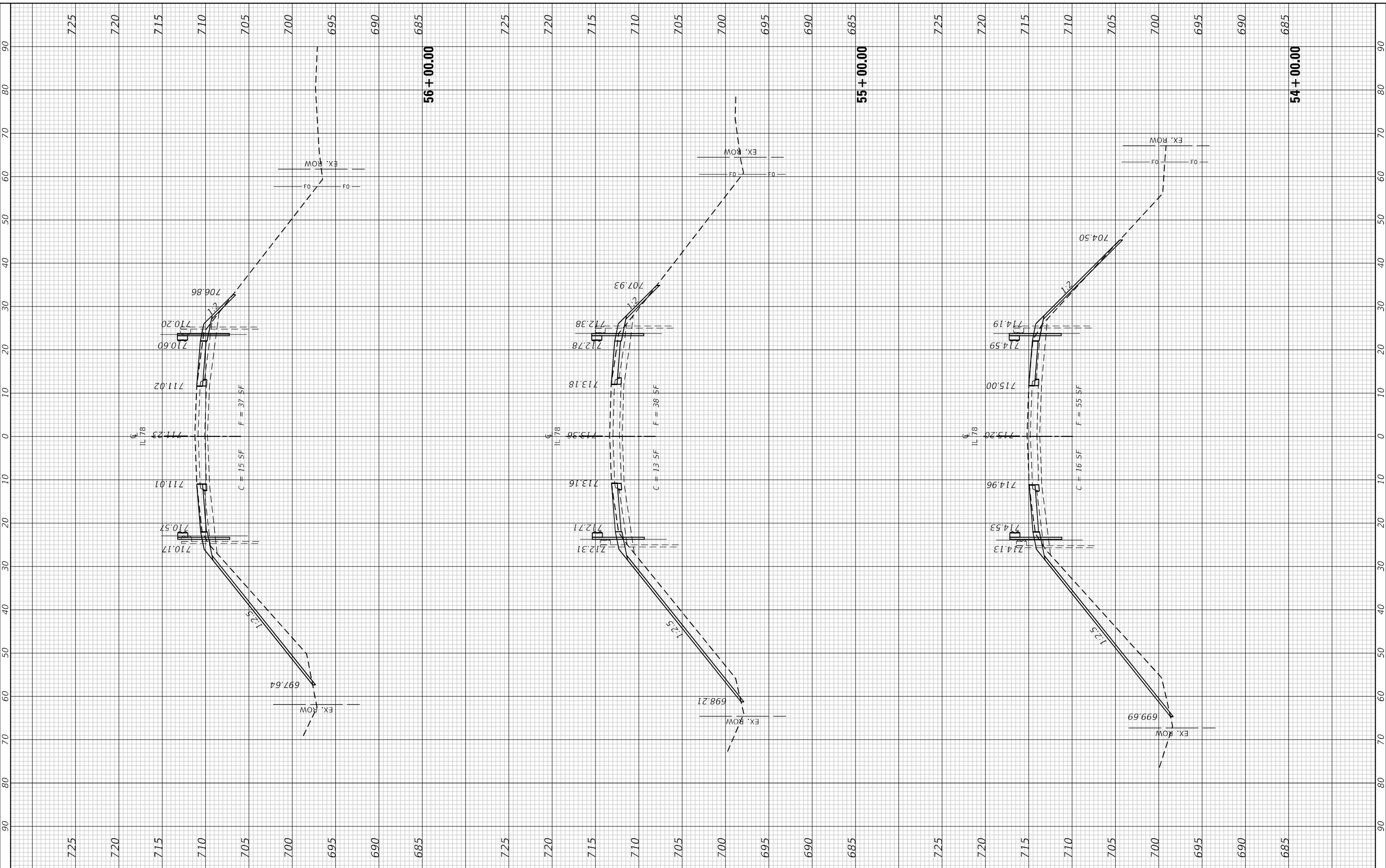

**TWM, INC.**  
WWW.TWM-INC.COM  
ILLINOIS DESIGN FIRM LICENSE NO: 184-001220

USER NAME = bbillhartz  
DESIGNED -  
DRAWN -  
CHECKED -  
DATE -  
PLOT SCALE = 20.0000' / in.  
PLOT DATE = 10/4/2023

REVISIONS:  
REVISIONS -  
REVISIONS -  
REVISIONS -  
REVISIONS -

**STATE OF ILLINOIS  
DEPARTMENT OF TRANSPORTATION**

**CROSS SECTIONS  
IL 78**

SCALE: 1"=10'    SHEET 7 OF 9 SHEETS    STA. 54+00.00 TO STA. 56+00.00

F.A.I. RTE.	SECTION	COUNTY	TOTAL SHEETS	SHEET NO.
74	[[72-30;48-29)HB-1]BRR	PEORIA & KNOX	115	69
CONTRACT NO. 68D48				
ILLINOIS FED. AID PROJECT				

FINAL SURVEY NO.	SURVEYED	BY	DATE
NOTE BOOK	PLOTTED		
AREAS CHECKED	TEMPLATE		
AREAS CHECKED	AREAS CHECKED		

ORIGINAL SURVEY NO.	SURVEYED	BY	DATE
NOTE BOOK	PLOTTED		
AREAS CHECKED	TEMPLATE		
AREAS CHECKED	AREAS CHECKED		

MODEL: Definit  
 FILE NAME: P:\2021\12\1221\IL 78 over FAI 74 & Ch 184 CADD - DWG\67\_TrimCAD\_Sheets\68D48-ss-hh\IL78.dwg

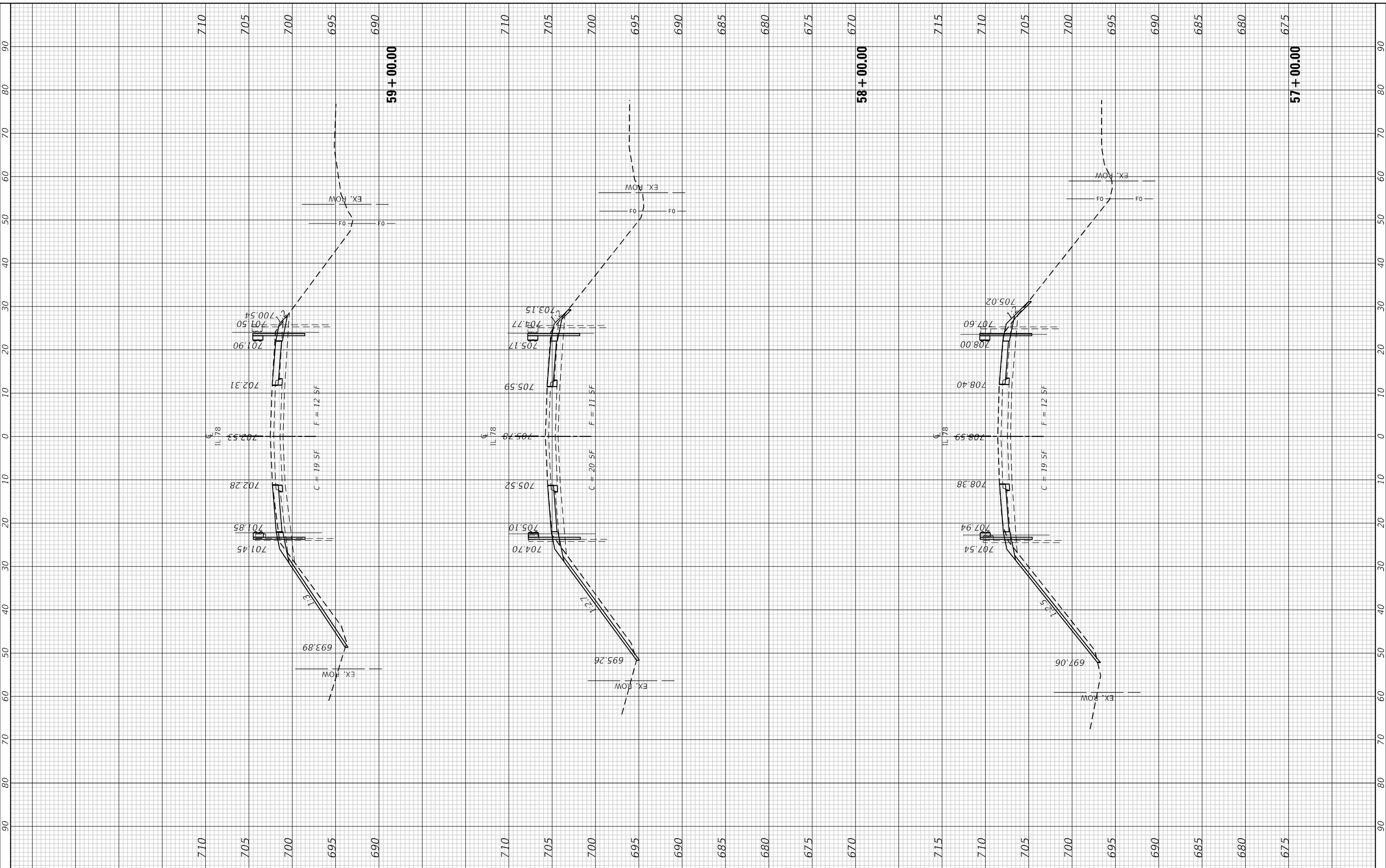

**TWM**  
 ENGINEERING  
 GEOSPATIAL SERVICES

**TWM, INC.**  
 WWW.TWM-INC.COM  
 IL DESIGN FIRM  
 LICENSE NO:  
 184-001220

USER NAME =	bbillhartz
DESIGNED -	
DRAWN -	
CHECKED -	
DATE -	

REVISD -	
REVISD -	
REVISD -	
REVISD -	

DESIGNED -	
DRAWN -	
CHECKED -	
DATE -	

**STATE OF ILLINOIS  
 DEPARTMENT OF TRANSPORTATION**

**CROSS SECTIONS  
 IL 78**

SCALE: 1"=10'    SHEET 8 OF 9 SHEETS    STA. 57+00.00 TO STA. 59+00.00

F.A.I. RTE.	SECTION	COUNTY	TOTAL SHEETS	SHEET NO.
74	[[72-30;48-29]HB-1]BRR	PEORIA & KNOX	115	70
CONTRACT NO. 68D48				
ILLINOIS FED. AID PROJECT				

FINAL SURVEY NO.	SURVEYED	BY	DATE
NOTE BOOK	PLOTTED		
AREAS CHECKED	TEMPLATE		
	AREAS		
	CHECKED		

ORIGINAL SURVEY NO.	SURVEYED	BY	DATE
NOTE BOOK	PLOTTED		
AREAS CHECKED	TEMPLATE		
	AREAS		
	CHECKED		

MODEL: Definit  
 FILE NAME: P:\2021\12\1221\IL - IL 78 over FAI 74 & Ch 184 CADD - DWG\1277 Trm\CAD\_Sheets\68D48-ss-shh\IL78.dwg

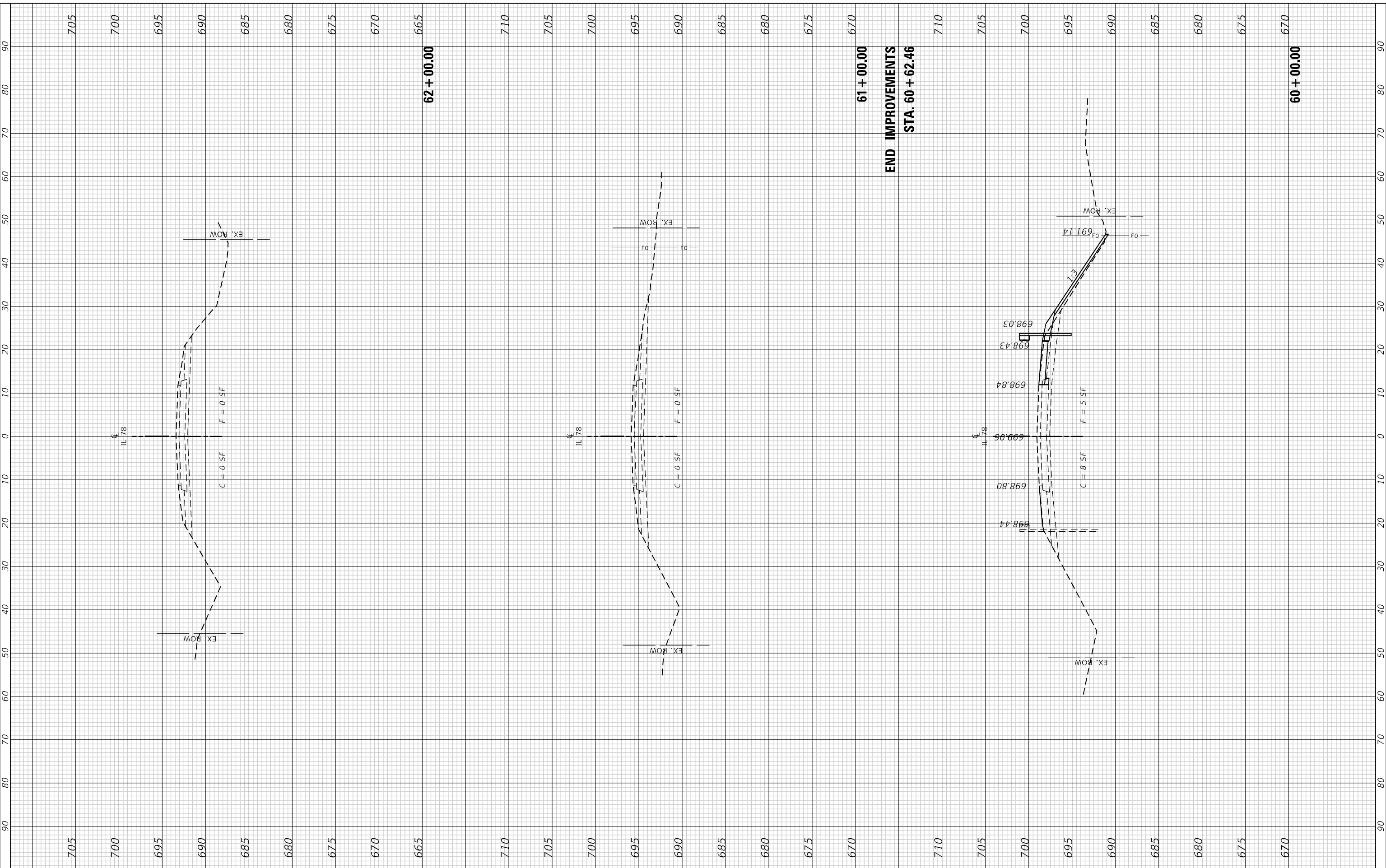

**61 + 00.00**  
**END IMPROVEMENTS**  
**STA. 60 + 62.46**

**60 + 00.00**

**TWM**  
 ENGINEERING  
 GEOSPATIAL SERVICES

**TWM, INC.**  
 WWW.TWM-INC.COM  
 IL DESIGN FIRM  
 LICENSE NO:  
 184-001220

USER NAME =	bbillhartz
DESIGNED -	
DRAWN -	
CHECKED -	
DATE -	

REVISD -	
REVISD -	
REVISD -	
REVISD -	

**STATE OF ILLINOIS**  
**DEPARTMENT OF TRANSPORTATION**

SCALE: 1"=10'	SHEET 9	OF 9	SHEETS	STA. 60+00.00	TO STA. 62+00.00
---------------	---------	------	--------	---------------	------------------

**CROSS SECTIONS**  
**IL 78**

F.A.I. RTE.	SECTION	COUNTY	TOTAL SHEETS	SHEET NO.
74	[(72-30;48-29)HB-1]BRR	PEORIA & KNOX	115	71
CONTRACT NO. 68D48			ILLINOIS   FED. AID PROJECT	





STRUCTURAL DESIGN TRAFFIC: YEAR 2023

PV = 322 SU = 33 MU = 11

ROAD/ STREET CLASSIFICATION: CLASS IV

PERCENT OF STRUCTURAL DESIGN TRAFFIC IN DESIGN LANE:

P = 50% S = 50% M = 50%

TRAFFIC FACTOR: ACTUAL TF = HCV = 22 \* MINIMUM TF = N/A

PG GRADE: TOP BINDER = LOWER BINDER = N/A

SURFACE =

SUBGRADE SUPPORT RATING:

SSR = POOR (STA. 48+29.76 TO STA. 48+71.78)

SSR = POOR (STA. 51+15.72 TO STA. 52+01.99)

\* FOR CLASS IV ROADWAYS, PAVEMENT THICKNESSES ARE PROVIDED IN BLR SECTION 44-3.03(b) BASED ON THE DAILY VOLUME OF HEAVY COMMERCIAL VEHICLES (HCV). THEREFORE, A DESIGN TF IS NOT NECESSARY.

**LEGEND**

- LEGEND ITEMS IN LIGHT SHADED TEXT ARE FOR THE IL 78 STRUCTURE
- (A) EX. EMBANKMENT
  - (B) EX. TOP SOIL, 4"
  - (C) EX. SUBBASE GRANULAR MATERIAL, 4" AND VARIES
  - (D) EX. HMA
  - (E) EX. BAM, 8"
  - (F) EX. AGGREGATE SHOULDERS
  - (G) EX. GUARDRAIL
  - (H) EX. HMA SHOULDERS, 8"
  - (I) EX. OIL & CHIP
  - (J) EX. AGGREGATE BASE COURSE
- (1) PR. HMA SURFACE REMOVAL - BUTT JOINT
  - (2) PR. HMA SURFACE COURSE, IL-9.5, MIX "D", N50, 1.5"
  - (3) PR. HMA SURFACE COURSE, IL-9.5, MIX "D", N50, 2"
  - (4) PR. HMA BINDER COURSE, IL-9.5, N50, 1.75"
  - (5) PR. HMA SURFACE REMOVAL (SPECIAL)
  - (6) PR. BITUMINOUS SURFACE TREATMENT, A2
  - (7) PR. BITUMINOUS MATERIALS (FOG SEAL)
  - (8) PR. HMA SHOULDERS, 2"
  - (9) PR. HMA SHOULDERS, 3.25"
  - (10) PR. AGGREGATE WEDGE SHOULDER, TYPE B
  - (11) PR. AGGREGATE SHOULDERS, TYPE B 8"
  - (12) PR. PAVEMENT REMOVAL
  - (13) PR. BASE COURSE WIDENING, 9"
  - (14) PR. AGGREGATE BASE COURSE TYPE A, 11"
  - (15) PR. STEEL PLATE BEAM GUARDRAIL, TYPE A, 6 FOOT POSTS
  - (16) PR. GUARDRAIL AGGREGATE EROSION CONTROL
  - (17) PR. CURB AND GUTTER (SPECIAL)
  - (18) PR. MODIFIED URETHANE PAVEMENT MARKING - LINE 4"
  - (19) PR. EMBANKMENT
  - (20) PR. PARALLEL WINGWALL (SEE BRIDGE PLANS)
  - (21) PR. HMA SHOULDERS, 8"
  - (22) PR. TOPSOIL FURNISH AND PLACE, 4"
  - (23) PR. SUBBASE GRANULAR MATERIAL, TYPE C
  - (24) PR. AGGREGATE SHOULDERS, TYPE B

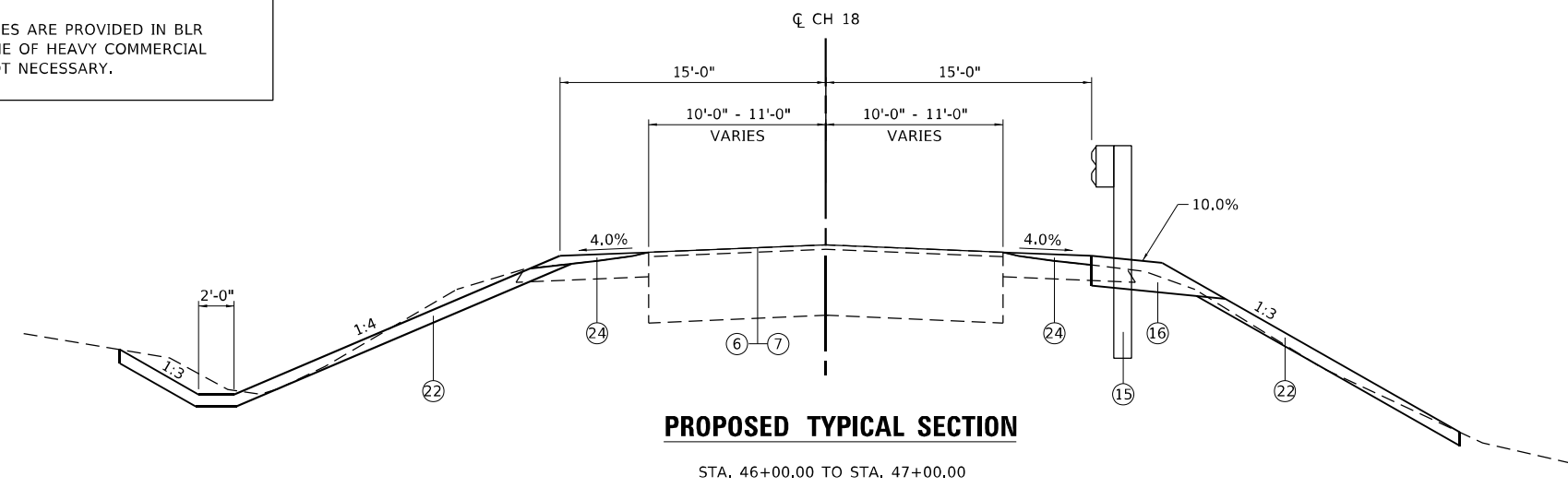

**PROPOSED TYPICAL SECTION**

STA. 46+00.00 TO STA. 47+00.00

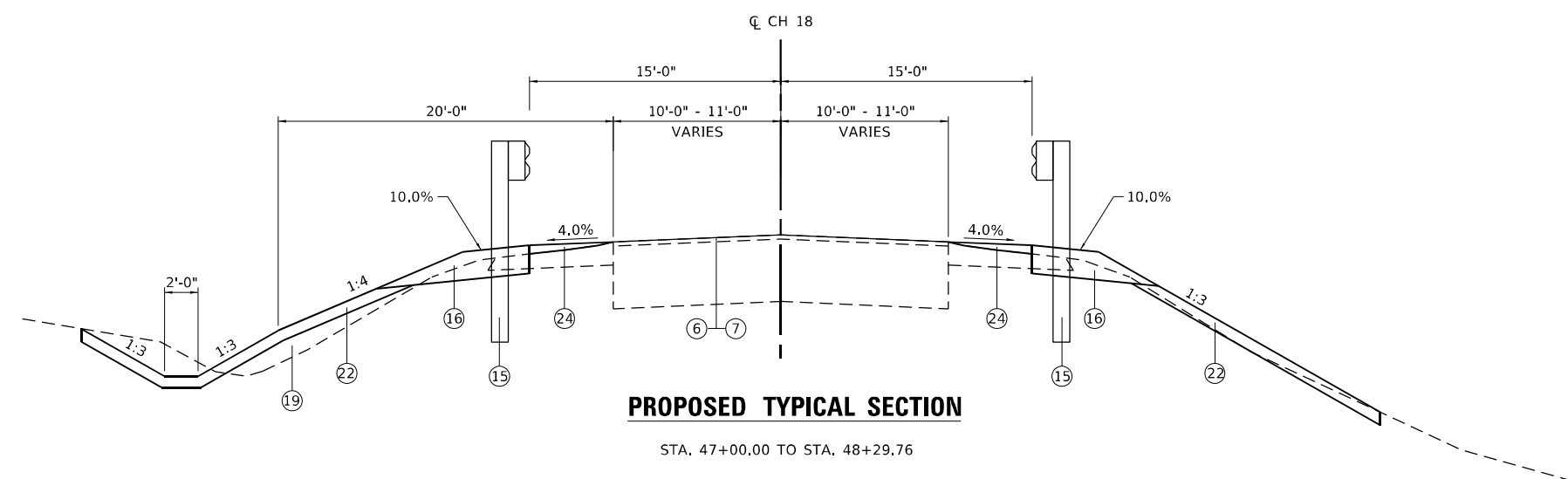

**PROPOSED TYPICAL SECTION**

STA. 47+00.00 TO STA. 48+29.76

**SN 048-0035**

(EXISTING BACK-TO-BACK BRIDGE DECK)  
STA. 48+71.83 TO STA. 51+15.67  
(SEE NOTE)

NOTE: THE PROPOSED HMA PAVEMENT, HMA SHOULDER, AND AGGREGATE BASE COURSE TYPE A WILL BE CONSTRUCTED TO PROPOSED BRIDGE DECK.

MODEL: D:\p\h\... FILE NAME: P:\2023\112122\NC - IL 78 over FAI 74 & CH 184 CADD - DWG\4.7 FromCAD\_Sheets\184BDD18-shr-typical CH18.dwg



USER NAME = bbillhartz	DESIGNED -	REVISED -
PLOT SCALE = 20,0000 * / in.	DRAWN -	REVISED -
PLOT DATE = 10/4/2023	CHECKED -	REVISED -
	DATE -	REVISED -

STATE OF ILLINOIS  
DEPARTMENT OF TRANSPORTATION

**PROPOSED TYPICAL SECTIONS  
CH 18**

SCALE: N.T.S. SHEET 2 OF 4 SHEETS STA. TO STA.

F.A.I. RTE.	SECTION	COUNTY	TOTAL SHEETS	SHEET NO.
74	[(72-30;48-29)HB-1]BRR	PEORIA & KNOX	115	73
CONTRACT NO. 68D48				
ILLINOIS FED. AID PROJECT				



## LEGEND

LEGEND ITEMS IN LIGHT SHADED TEXT ARE FOR THE IL 78 STRUCTURE

- (A) EX. EMBANKMENT
  - (B) EX. TOP SOIL, 4"
  - (C) EX. SUBBASE GRANULAR MATERIAL, 4" AND VARIES
  - (D) EX. HMA
  - (E) EX. BAM, 8"
  - (F) EX. AGGREGATE SHOULDERS
  - (G) EX. GUARDRAIL
  - (H) EX. HMA SHOULDERS, 8"
  - (I) EX. OIL & CHIP
  - (J) EX. AGGREGATE BASE COURSE
- (1) PR. HMA SURFACE REMOVAL - BUTT JOINT
  - (2) PR. HMA SURFACE COURSE, IL-9.5, MIX "D", N50, 1.5"
  - (3) PR. HMA SURFACE COURSE, IL-9.5, MIX "D", N50, 2"
  - (4) PR. HMA BINDER COURSE, IL-9.5, N50, 1.75"
  - (5) PR. HMA SURFACE REMOVAL (SPECIAL)
  - (6) PR. BITUMINOUS SURFACE TREATMENT, A2
  - (7) PR. BITUMINOUS MATERIALS (FOG SEAL)
  - (8) PR. HMA SHOULDERS, 2"
  - (9) PR. HMA SHOULDERS, 3.25"
  - (10) PR. AGGREGATE WEDGE SHOULDER, TYPE B
  - (11) PR. AGGREGATE SHOULDERS, TYPE B 8"
  - (12) PR. PAVEMENT REMOVAL
  - (13) PR. BASE COURSE WIDENING, 9"
  - (14) PR. AGGREGATE BASE COURSE TYPE A, 11"
  - (15) PR. STEEL PLATE BEAM GUARDRAIL, TYPE A, 6 FOOT POSTS
  - (16) PR. GUARDRAIL AGGREGATE EROSION CONTROL
  - (17) PR. CURB AND GUTTER (SPECIAL)
  - (18) PR. MODIFIED URETHANE PAVEMENT MARKING - LINE 4"
  - (19) PR. EMBANKMENT
  - (20) PR. PARALLEL WINGWALL (SEE BRIDGE PLANS)
  - (21) PR. HMA SHOULDERS, 8"
  - (22) PR. TOPSOIL FURNISH AND PLACE, 4"
  - (23) PR. SUBBASE GRANULAR MATERIAL, TYPE C
  - (24) PR. AGGREGATE SHOULDERS, TYPE B

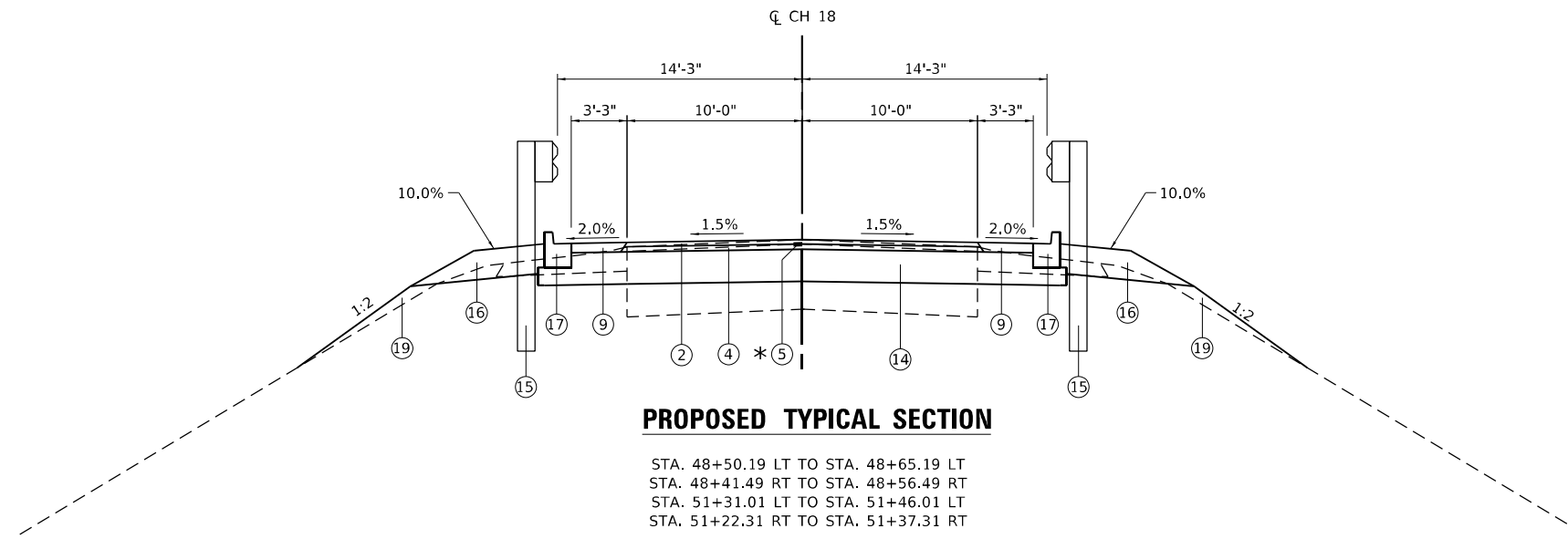

\* SEE SPECIAL PROVISION HMA JOINT TRIMMING

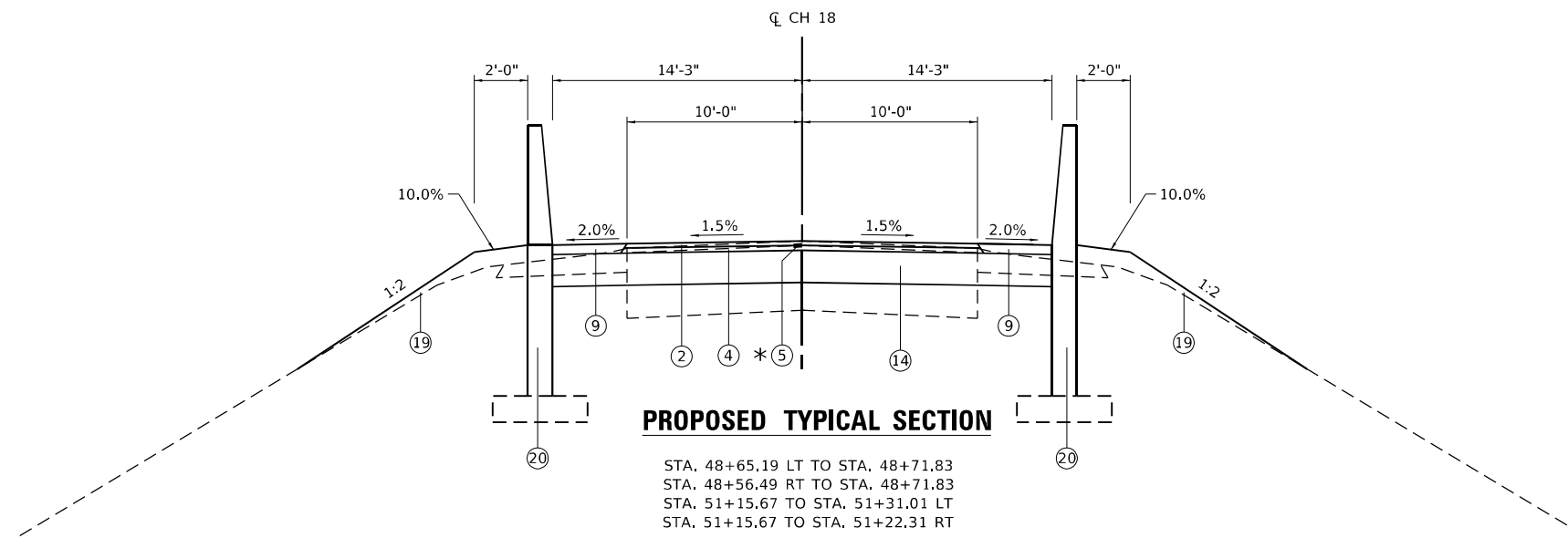

\* SEE SPECIAL PROVISION HMA JOINT TRIMMING

## SN 048-0035

(EXISTING BACK-TO-BACK BRIDGE DECK)  
 STA. 48+71.83 TO STA. 51+15.67  
 (SEE NOTE)

NOTE: THE PROPOSED HMA PAVEMENT, HMA SHOULDER, AND AGGREGATE BASE COURSE TYPE A WILL BE CONSTRUCTED TO PROPOSED BRIDGE DECK.

MODEL: D:\p\h\...  
 FILE NAME: P:\2021\121122\NC - IL 78 over FA1 74 & CH 184 CADD - DWG\4.7\_TranCAD\_Sheets\148BDD18-ehz-typical CH18.dgn



**TWM, INC.**  
 www.twm-inc.com  
 IL DESIGN FIRM  
 LICENSE NO:  
 184-001220

USER NAME = bbillhartz	DESIGNED -	REVISED -
PLOT SCALE = 20,0000 * / in.	DRAWN -	REVISED -
PLOT DATE = 10/4/2023	CHECKED -	REVISED -
	DATE -	REVISED -

**STATE OF ILLINOIS**  
**DEPARTMENT OF TRANSPORTATION**

**PROPOSED TYPICAL SECTIONS**  
**CH 18**

SCALE: N.T.S. SHEET 4 OF 4 SHEETS STA. TO STA.

F.A.I. RTE.	SECTION	COUNTY	TOTAL SHEETS	SHEET NO.
74	[(72-30;48-29)HB-1]BRR	PEORIA & KNOX	115	75
CONTRACT NO. 68D48				
ILLINOIS FED. AID PROJECT				

SEEDING SCHEDULE										
LOCATION				25000210	25000400	25000500	25000600	25100630	25100635	28000250
				SEEDING, CLASS 2A	NITROGEN FERTILIZER NUTRIENT	PHOSPHORUS FERTILIZER NUTRIENT	POTASSIUM FERTILIZER NUTRIENT	EROSION CONTROL BLANKET	HEAVY DUTY EROSION CONTROL BLANKET	TEMPORARY EROSION CONTROL SEEDING
STATION	TO	STATION	LT/RT	ACRE	POUND	POUND	POUND	SQ YD	SQ YD	POUND
SN 048-0035										
46+00.00	TO	48+29.76	LT					723.0		
46+00.00	TO	49+30.34	LT	0.210	18.9	18.9	18.9			42.0
46+00.00	TO	48+29.76	RT					541.5		
46+00.00	TO	49+13.84	RT	0.153	13.8	13.8	13.8			30.6
48+29.76	TO	49+25.43	LT						312.9	
48+29.76	TO	49+13.84	RT						213.3	
50+84.30	TO	56+29.81	LT	0.151	13.6	13.6	13.6		779.0	30.2
50+69.36	TO	56+29.81	RT	0.187	16.8	16.8	16.8		967.4	37.4
TOTAL:				0.701	63.1	63.1	63.1	1264.5	2272.6	140.2
PAY TOTAL:				0.75	65	65	65	1265	2273	140

FENCE SCHEDULE					
LOCATION				66500105	X6650202
				WOVEN WIRE FENCE, 4'	WOVEN WIRE FENCE REMOVAL
STATION	TO	STATION	LT/RT	FOOT	FOOT
SN 048-0035					
48+62.39	TO	48+63.85	LT	42.2	
48+62.39	TO	48+81.33	LT		45.4
48+32.57	TO	48+55.15	RT	44.9	
48+68.50	TO	48+25.66	RT		52.1
51+32.35	TO	51+50.20	LT	63.5	
51+17.50	TO	51+50.20	LT		68.4
51+19.18	TO	51+23.65	RT	53.1	
51+07.00	TO	51+19.18	RT		54.9
TOTAL:				203.7	220.8
PAY TOTAL:				204	221

EARTHWORK SCHEDULE							
LOCATION			20200100	FOR INFORMATION ONLY		20400800	21101615
			EARTH EXCAVATION	EARTH EXCAVATION ADJUSTED FOR 25% SHRINKAGE	EMBANKMENT	BALANCE WASTE (+) SHORTAGE (-)	FURNISHED EXCAVATION
STATION	TO	STATION	CU YD	CU YD	CU YD	CU YD	SQ YD
SN 048-0035							
STA. 46+00 TO STA. 55+00			287	215	301	-86	3390.4
SUB-TOTAL:			287	215	301	-86	3390.4
PAY TOTAL:			290				3390

EROSION SCHEDULE						
LOCATION				28000305	28000400	28000500
				TEMPORARY DITCH CHECKS	PERIMETER EROSION BARRIER	INLET AND PIPE PROTECTION
STATION	TO	STATION	LT/RT	FOOT	FOOT	EACH
SN 048-0035						
46+00.00	TO		LT	7.0		
46+50.00	TO		LT	7.0		
47+00.00	TO		LT	7.0		
47+50.00	TO		LT	7.0		
48+00.00	TO		LT	7.0		
48+29.76	TO		LT	7.0		
46+00.00	TO	49+13.84	RT		348.4	
46+30.99	TO					1.0
48+29.76	TO	49+25.43	LT		141.4	
50+73.96	TO	56+29.81	RT		628.7	
50+84.30	TO	56+29.81	LT		612.1	
TOTAL:				42.0	1730.6	1.0
PAY TOTAL:				42	1731	1

MOWING SCHEDULE			
LOCATION			25000750
			MOWING
			ASSUMING 2 MOWINGS
STATION	TO	STATION	ACRE
SN 048-0035			
46+00.00	TO	49+25.43	0.224
46+00.00	TO	49+13.84	0.216
50+84.30	TO	55+32.71	0.308
50+73.96	TO	56+29.81	0.382
TOTAL:			1.13
PAY TOTAL:			1.25

MISCELLANEOUS SCHEDULE	
60100060	
LOCATION	CONCRETE HEADWALLS FOR PIPE DRAINS
STATION	EACH
SN 048-0035	
NE QUADRANT	1.0
NW QUADRANT	1.0
SE QUADRANT	1.0
SW QUADRANT	1.0
TOTAL:	4.0
PAY TOTAL:	4

SEE STRUCTURE PLANS FOR ADDITIONAL DETAILS

MODEL: D:\p\h\h...  
 FILE NAME: P:\2021\112121\112121\C - IL 78 over FAI 74 & CH 184 CADD - DWG\4.7 Trim\CADD\_Sheets\11488018\_sht-structure-CH 18.dgn



USER NAME = bbillhartz	DESIGNED -	REVISED -
PLOT SCALE = 2,000' / in.	DRAWN -	REVISED -
PLOT DATE = 10/4/2023	CHECKED -	REVISED -
	DATE -	REVISED -

STATE OF ILLINOIS  
DEPARTMENT OF TRANSPORTATION

SCHEDULE OF QUANTITIES			
CH 18			
SCALE:	SHEET 1	OF 3 SHEETS	STA. TO STA.

F.A.I. RTE.	SECTION	COUNTY	TOTAL SHEETS	SHEET NO.
74	[(72-30;48-29)HB-1]BRR	PEORIA & KNOX	115	76
				CONTRACT NO. 68D48
		ILLINOIS	FED. AID PROJECT	



MAINLINE PAVING SCHEDULE												
LOCATION				35101000	40600275	40600290		40602978	40604060		X0300010	X1500005
				AGGREGATE BASE COURSE, TYPE A 11"	BITUMINOUS MATERIALS (PRIME COAT)	BITUMINOUS MATERIALS (TACK COAT)		HOT-MIX ASPHALT BINDER COURSE, IL-9.5, N50	HOT-MIX ASPHALT SURFACE COURSE, IL-9.5, MIX "D", N50		BITUMINOUS MATERIALS (FOG SEAL)	BITUMINOUS SURFACE TREATMENT, A2
STATION	TO	STATION	LT/RT	SQ YD	POUND	POUND	POUND	TON	TON	TON		
<b>SN 048-0035</b>												
46+00.00	TO	48+29.76	LT/RT								254.78	566.17
48+29.76	TO	48+71.83	LT/RT	119.2	220.5	21.0	0.52	9.1	7.8	0.2		
51+15.67	TO	52+01.99	LT/RT	217.6	452.8	43.1	1.08	18.8	16.1	0.4		
52+01.99	TO	56+29.81	LT/RT								457.52	1016.71
SUBTOTAL:				336.8	673.2	64.1	1.6	27.9	23.9	0.6	712.3	1582.9
TOTAL:				336.8	673.2	65.7		27.9	24.5		712.3	1582.9
PAY TOTAL:				337	673	66		28	25		712	1583

RIPRAP SCHEDULE			
LOCATION		28200200	X2810128
		FILTER FABRIC	STONE RIPRAP, CLASS B4 (SPECIAL)
STATION	LT/RT	SQ YD	SQ YD
<b>SN 048-0035</b>			
51+46.01	LT	5.6	5.6
51+37.31	RT	5.6	5.6
TOTAL:		11.1	11.1
PAY TOTAL:		11	11

TREE REMOVAL SCHEDULE					
LOCATION				20100110	20100210
				TREE REMOVAL (6 TO 15 UNITS DIAMETER)	TREE REMOVAL (OVER 15 UNITS DIAMETER)
STATION	TO	STATION	LT/RT	UNIT	UNIT
<b>SN 048-0035</b>					
48+23.65	TO	48+39.65	LT	9	88
TOTAL:				9.0	88.0
PAY TOTAL:				9	88

SHOULDER SCHEDULE						
LOCATION				48101200	48101600	48203010
				AGGREGATE SHOULDERS, TYPE B	AGGREGATE SHOULDERS, TYPE B 8"	HOT-MIX ASPHALT SHOULDERS, 3.25"
STATION	TO	STATION	LT/RT	TON	SQ YD	SQ YD
<b>SN 048-0035</b>						
46+00.00	TO	48+29.76	LT	17.8		
46+00.00	TO	48+29.76	RT	17.9		
48+29.76	TO	48+50.19	LT		9.7	
48+29.76	TO	48+41.49	RT		5.5	
48+50.19	TO	48+71.83	LT			10.3
48+41.49	TO	48+71.83	RT			10.9
51+15.67	TO	51+46.01	LT			10.9
51+15.67	TO	51+37.31	RT			10.3
51+46.01	TO	52+01.99	LT		27.5	
51+37.31	TO	52+01.99	RT		32.3	
52+01.99	TO	56+29.81	LT	38.0		
52+01.99	TO	56+29.81	RT	33.2		
TOTAL:				106.8	74.9	42.3
PAY TOTAL:				107	75	42

MODEL: D:\p6\h...  
 FILE NAME: P:\2021\112121\112121\CADD - DWG\4.7\_TrimCAD\_Sheets\112121\112121\CADD - CH 1B4\_CADD - DWG\4.7\_TrimCAD\_Sheets\112121\112121\CADD - CH 1B4\_CADD - DWG\4.7\_TrimCAD\_Sheets\112121\112121\CADD - CH 1B4.dgn



**TWM, INC.**  
 www.twm-inc.com  
 IL DESIGN FIRM  
 LICENSE NO:  
 184-001220

USER NAME = bblilhartz	DESIGNED -	REVISED -
PLOT SCALE = 2,000' / in.	DRAWN -	REVISED -
PLOT DATE = 10/4/2023	CHECKED -	REVISED -
	DATE -	REVISED -

**STATE OF ILLINOIS  
 DEPARTMENT OF TRANSPORTATION**

SCHEDULE OF QUANTITIES				
CH 18				
SCALE:	SHEET 3	OF 3	SHEETS	STA. TO STA.

F.A.I. RTE.	SECTION	COUNTY	TOTAL SHEETS	SHEET NO.
74	[(72-30;48-29)HB-1]BRR	PEORIA & KNOX	115	78
CONTRACT NO. 68D48				
ILLINOIS FED. AID PROJECT				

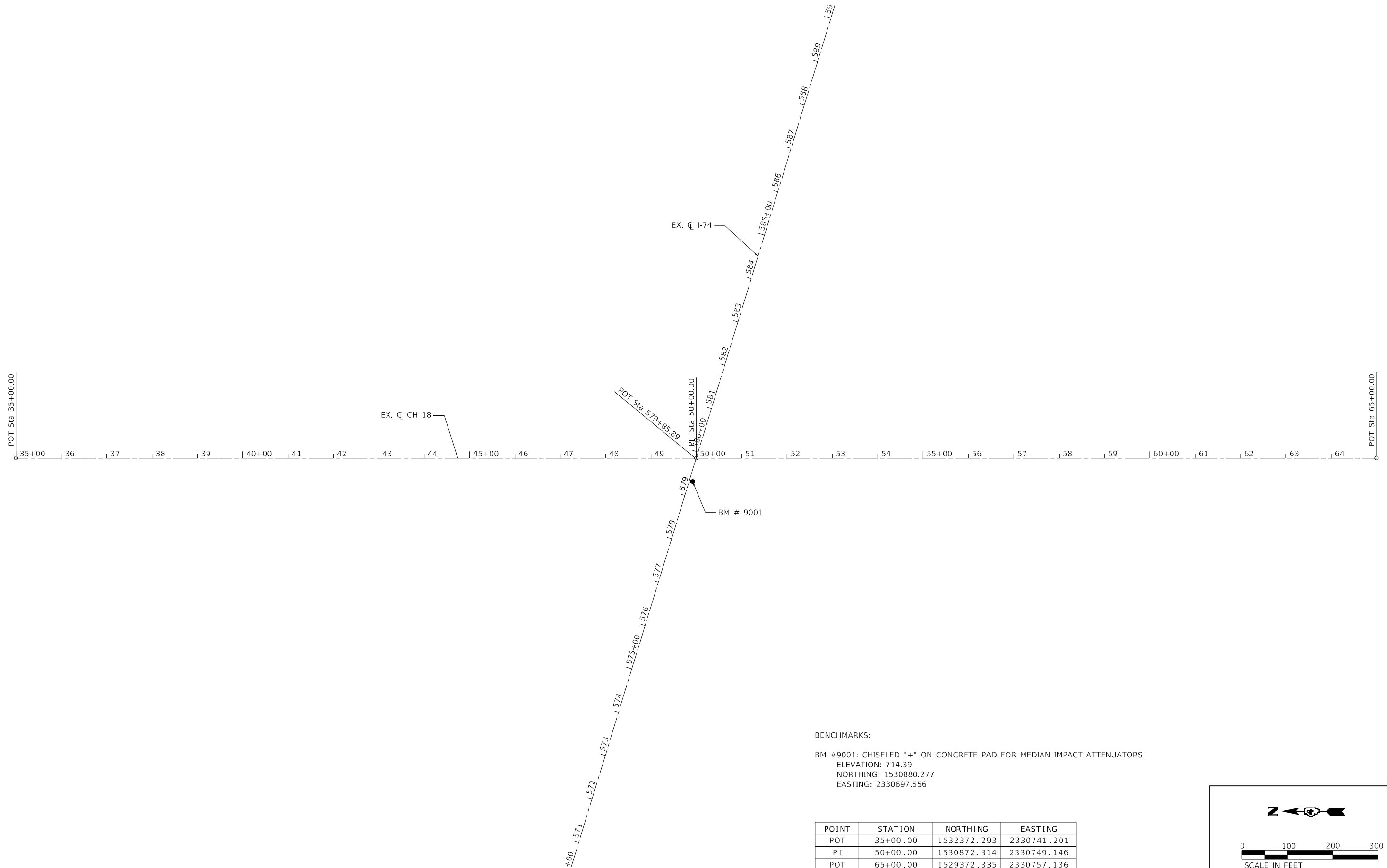

**BENCHMARKS:**

BM #9001: CHISELED "+" ON CONCRETE PAD FOR MEDIAN IMPACT ATTENUATORS  
 ELEVATION: 714.39  
 NORTHING: 1530880.277  
 EASTING: 2330697.556

POINT	STATION	NORTHING	EASTING
POT	35+00.00	1532372.293	2330741.201
PI	50+00.00	1530872.314	2330749.146
POT	65+00.00	1529372.335	2330757.136

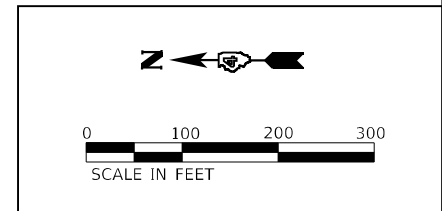

MODEL: D:\p1\112121\112121.dwg  
 FILE NAME: P:\2023\112121\112121.dwg - ILL 78 over FAI 74 & CH 184 CADD - DWG\4.7 FromCAD\_Sheets\112121.dwg-ATR-CH 18.dwg



**TWM, INC.**  
 WWW.TWM-INC.COM  
 IL DESIGN FIRM LICENSE NO: 184-001220

USER NAME = bbillhartz	DESIGNED -	REVISED -
PLOT SCALE = 200,0000' / in.	DRAWN -	REVISED -
PLOT DATE = 10/4/2023	CHECKED -	REVISED -
	DATE -	REVISED -

**STATE OF ILLINOIS  
 DEPARTMENT OF TRANSPORTATION**

**ALIGNMENT, TIES & BENCHMARKS  
 CH 18**

F.A.I. RTE.	SECTION	COUNTY	TOTAL SHEETS	SHEET NO.
74	[(72-30;48-29)HB-1]BRR	PEORIA & KNOX	115	79
CONTRACT NO. 68D48				
ILLINOIS FED. AID PROJECT				

SCALE: 1"=100' SHEET 1 OF 1 SHEETS STA. 35+00.00 TO STA. 65+00.00





PLAN	SURVEYED	DATE
	PLOTTED	BY
	ALIGNMENT CHECKED	
	GRADE CHECKED	
	STRUCTURE NOTATIONS CHECKED	
	NO.	
	NOTE BOOK NO.	
	CADD FILE NAME	

PROFILE	SURVEYED	DATE
	PLOTTED	BY
	GRADES CHECKED	
	STRUCTURE NOTATIONS CHECKED	
	NO.	
	NOTE BOOK NO.	
	CADD FILE NAME	

MODEL: Defnair  
 FILE NAME: P:\2023\12\12\21\C - IL 78 over FAI 74 & Ch 18.d CADD - DWG\47 - Tran\CAI\_Sheets\048B\048-shr-hp\pr\Ch 18.d.dgn

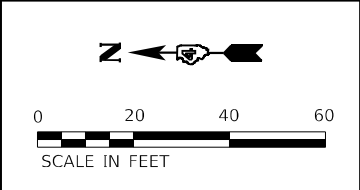
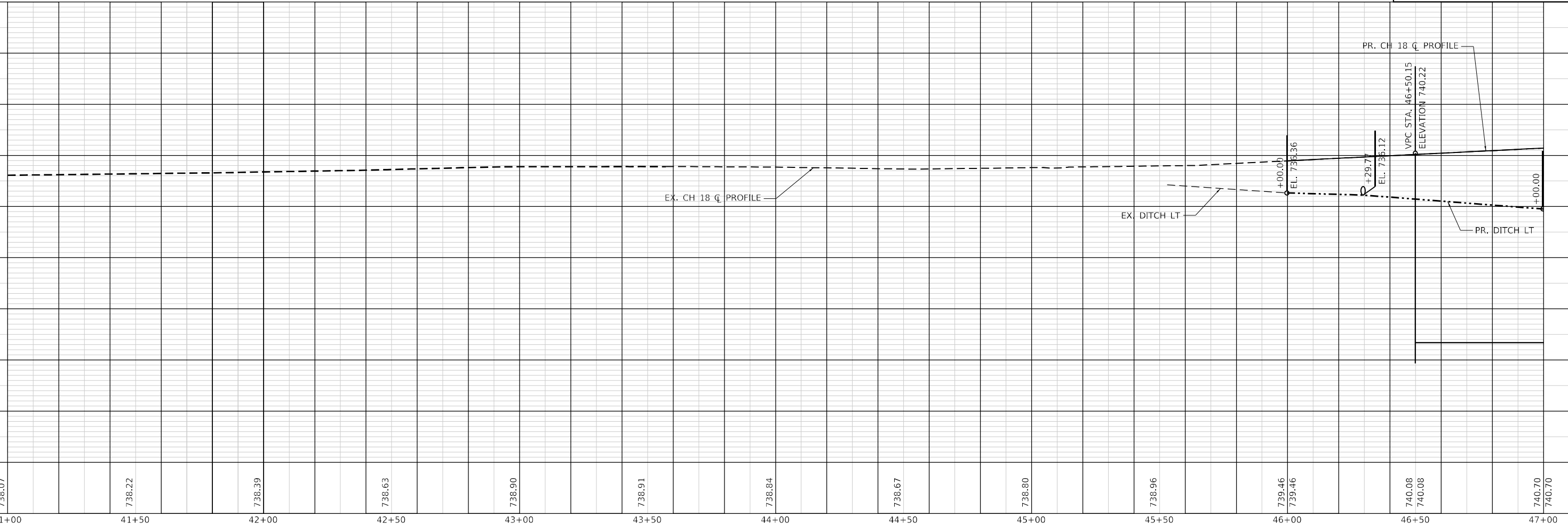
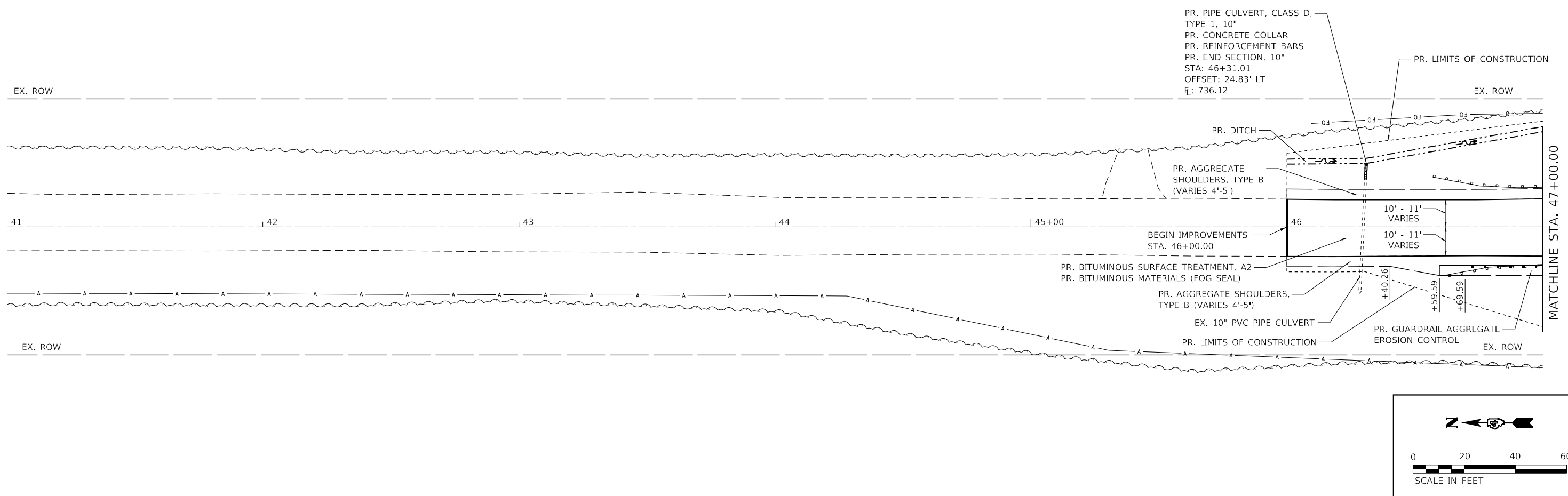

**TWM, INC.**  
 WWW.TWM-INC.COM  
 IL DESIGN FIRM LICENSE NO: 184-001220  
 USER NAME = bbillhartz  
 PLOT SCALE = 40,0000 \* / in.  
 PLOT DATE = 10/01/2023

DESIGNED -	REVISD -
DRAWN -	REVISD -
CHECKED -	REVISD -
DATE -	REVISD -

**STATE OF ILLINOIS  
 DEPARTMENT OF TRANSPORTATION**

**PLAN AND PROFILE  
 CH 18**  
 SCALE: 1"=20'  
 SHEET 1 OF 3 SHEETS  
 STA. 41+00.00 TO STA. 47+00.00

F.A.I. RTE.	SECTION	COUNTY	TOTAL SHEETS	SHEET NO.
74	[(72-30;48-29)HB-1]BRR	PEORIA & KNOX	115	81
CONTRACT NO. 68D48			ILLINOIS FED. AID PROJECT	

DATE	
BY	
PLAN	SURVEYED
	PLOTTED
	ALIGNMENT CHECKED
	STRUCTURE NOTATIONS CHECKED
	CADD FILE NAME
	NO.

DATE	
BY	
PROFILE	SURVEYED
	PLOTTED
	GRADES CHECKED
	STRUCTURE NOTATIONS CHECKED
	CADD FILE NAME
	NO.

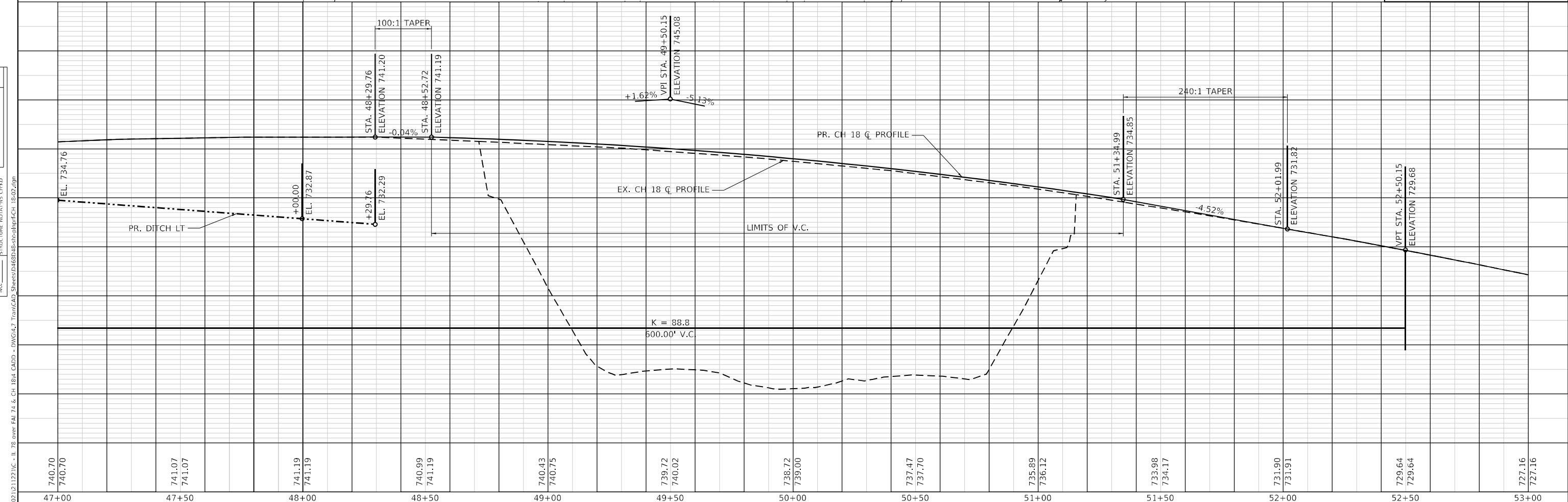
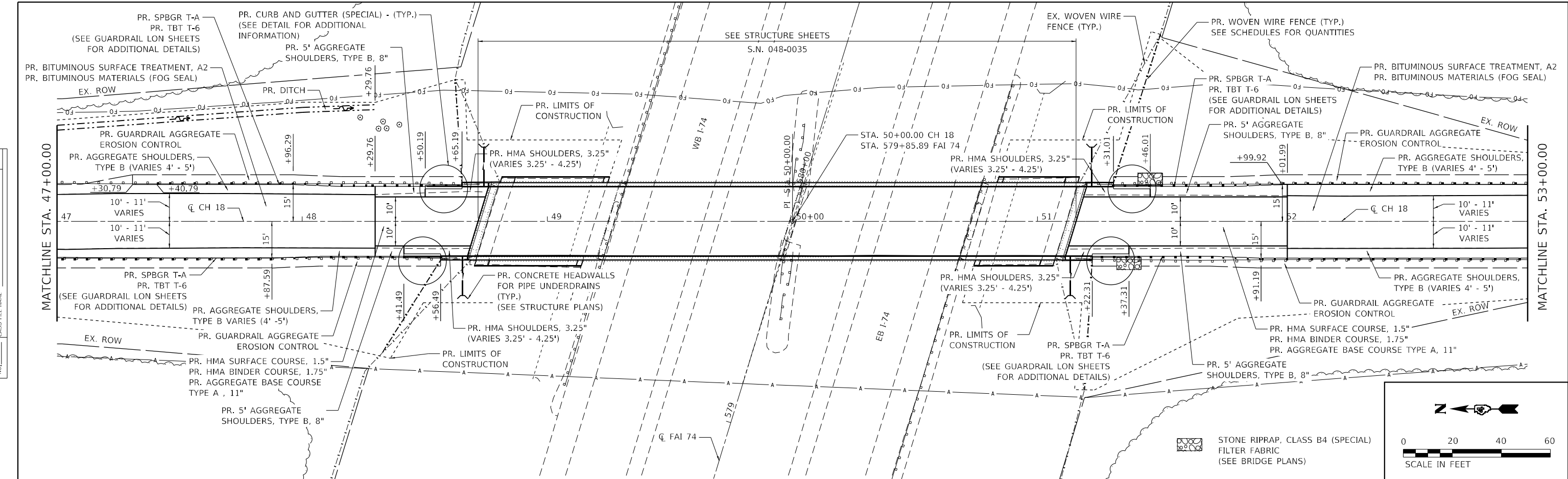

740.70	740.70	741.07	741.07	741.19	741.19	740.99	741.19	740.43	740.75	739.72	740.02	738.72	739.00	737.47	737.70	735.89	736.12	733.98	734.17	731.90	731.91	729.64	729.64	727.16	727.16
47+00	47+50	48+00	48+50	49+00	49+50	50+00	50+50	51+00	51+50	52+00	52+50	53+00													



**TWM, INC.**  
www.twm-inc.com  
IL DESIGN FIRM LICENSE NO: 184-001220

DESIGNED -	REVISIED -
DRAWN -	REVISIED -
CHECKED -	REVISIED -
DATE -	REVISIED -

**STATE OF ILLINOIS**  
**DEPARTMENT OF TRANSPORTATION**

**PLAN AND PROFILE**  
**CH 18**  
SCALE: 1"=20'  
SHEET 2 OF 3 SHEETS  
STA. 47+00.00 TO STA. 53+00.00

F.A.I. RTE.	SECTION	COUNTY	TOTAL SHEETS	SHEET NO.
74	[(72-30;48-29)HB-1]BRR	PEORIA & KNOX	115	82
CONTRACT NO. 68D48			ILLINOIS FED. AID PROJECT	

MODEL: Defnair  
FILE NAME: P:\2022\12\12\21C - II\_78 over FAI 74 & Ch 18.dwg  
CADD: DWG-47  
TranC48\_Sheets\68D48\BRR-1\BRR-1.dwg  
15:02:29





MODEL: D:\ef\h...  
 FILE NAME: P:\2023\121122\IC - IL 78 over FA 74 & CH 184 CADD - DWG\4.7 Tran\CADD\_Sheets\184BDD48-eh-eros-CH 18.dgn

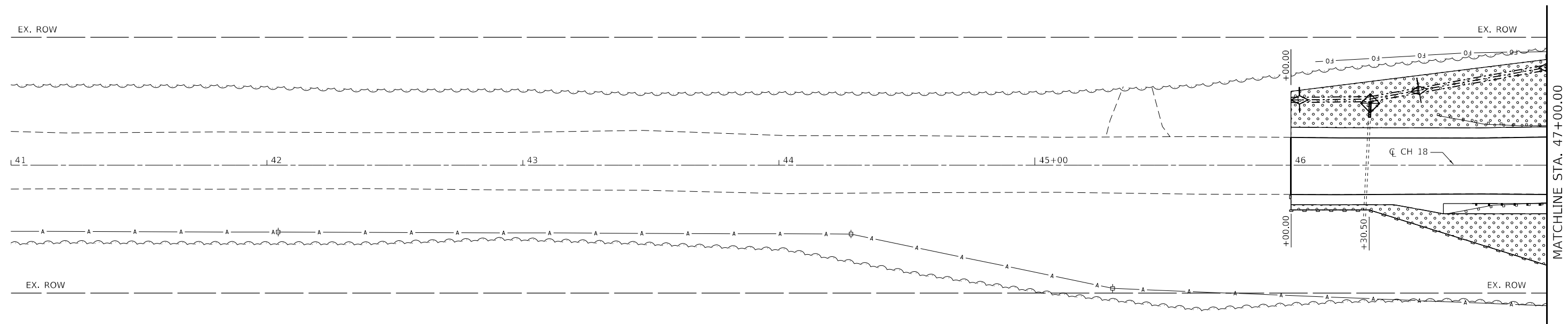

**NOTES:**

1. PLACE EROSION CONTROL BLANKET ON SLOPES FLATTER THAN 1:3
2. PLACE HEAVY DUTY EROSION CONTROL BLANKET ON SLOPES BETWEEN 1:3 AND 1:2

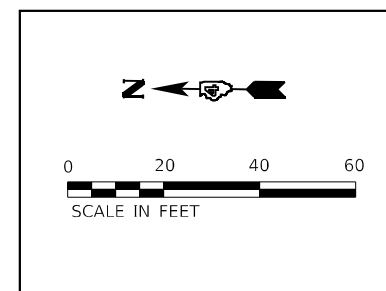

LEGEND	
	PR. SEEDING CLASS, 2A W/ FERTILIZER NUTRIENTS AND HEAVY-DUTY EROSION CONTROL BLANKET
	PR. SEEDING CLASS, 2A W/ FERTILIZER NUTRIENTS AND EROSION CONTROL BLANKET
	PR. TEMPORARY DITCH CHECK
	PR. INLET AND PIPE PROTECTION
	PR. PERIMETER EROSION BARRIER
	PR. STONE RIPRAP, CLASS B4 (SPECIAL)

**TWM, INC.**  
 WWW.TWM-INC.COM  
 IL DESIGN FIRM LICENSE NO: 184-001220

USER NAME = bbillhartz	DESIGNED -	REVISED -
PLOT SCALE = 40,0000 * / in.	DRAWN -	REVISED -
PLOT DATE = 10/4/2023	CHECKED -	REVISED -
	DATE -	REVISED -

**STATE OF ILLINOIS**  
**DEPARTMENT OF TRANSPORTATION**

**EROSION CONTROL PLAN**  
**CH 18**  
 SCALE: 1"=20'    SHEET 1 OF 3 SHEETS    STA. 41+00.00 TO STA. 47+00.00

F.A.I. RTE.	SECTION	COUNTY	TOTAL SHEETS	SHEET NO.
74	[(72-30;48-29)HB-1]BRR	PEORIA & KNOX	115	85
CONTRACT NO. 68D48				
ILLINOIS FED. AID PROJECT				



MODEL Path:\n FILE NAME: P:\2023\21122\NC - IL 78 over FA1 74 & CH 184 CADD - DWG\G4.7 FromCAD\_Sheets\184BDD48-eh-eros-CH 18.dgn

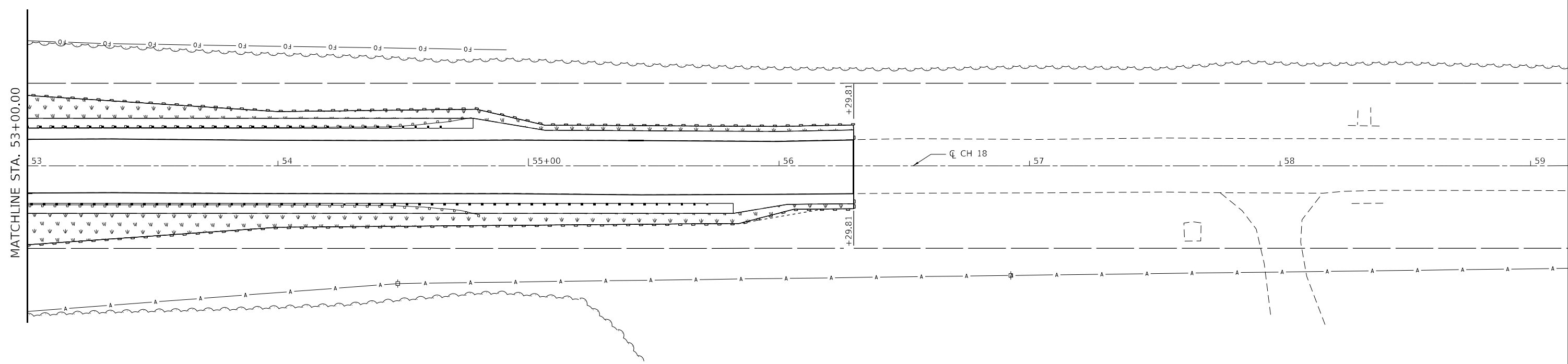

- NOTES:
- PLACE EROSION CONTROL BLANKET ON SLOPES FLATTER THAN 1:3
  - PLACE HEAVY DUTY EROSION CONTROL BLANKET ON SLOPES BETWEEN 1:3 AND 1:2

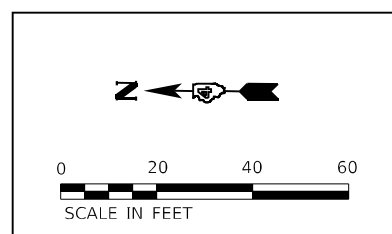

LEGEND	
	PR. SEEDING CLASS, 2A W/ FERTILIZER NUTRIENTS AND HEAVY-DUTY EROSION CONTROL BLANKET
	PR. SEEDING CLASS, 2A W/ FERTILIZER NUTRIENTS AND EROSION CONTROL BLANKET
	PR. TEMPORARY DITCH CHECK
	PR. INLET AND PIPE PROTECTION
	PR. PERIMETER EROSION BARRIER
	PR. STONE RIPRAP, CLASS B4 (SPECIAL)

**TWM**  
ENGINEERING  
GEOSPATIAL SERVICES

**TWM, INC.**  
WWW.TWM-INC.COM

IL DESIGN FIRM  
LICENSE NO:  
184-001220

USER NAME = bbillhartz	DESIGNED -	REVISED -
PLOT SCALE = 40,0000 * / in.	DRAWN -	REVISED -
PLOT DATE = 10/4/2023	CHECKED -	REVISED -
	DATE -	REVISED -

**STATE OF ILLINOIS  
DEPARTMENT OF TRANSPORTATION**

**EROSION CONTROL PLAN  
CH 18**

SCALE: 1"=20'    SHEET 3    OF 3    SHEETS    STA. 53+00.00    TO STA. 53+00.00

F.A.I. RTE.	SECTION	COUNTY	TOTAL SHEETS	SHEET NO.
74	[(72-30;48-29)HB-1]BRR	PEORIA & KNOX	115	87
CONTRACT NO. 68D48				
ILLINOIS FED. AID PROJECT				



Benchmark: BM 9001, Chiseled "+" on PCC Pad, Sta. 579+34.18, 7.20' Rt. of  $\text{C I-74}$ , Elev. 714.39.

Existing Structure: Structure No. 048-0035 was originally built in 1968 as F.A.I. Rt. 74, Section 48-29HB-1 in Knox County as a 4 span continuous non-composite steel beam (WF33 with cover plates) structure supporting a 7" R.C. slab. The substructure consists of concrete pile stub abutments and hammerhead piers. The existing back-to-back abutment length = 245'-6" and the o-o width is 32'-0". CH 18 will be closed during construction and traffic will be detoured.

No Salvage

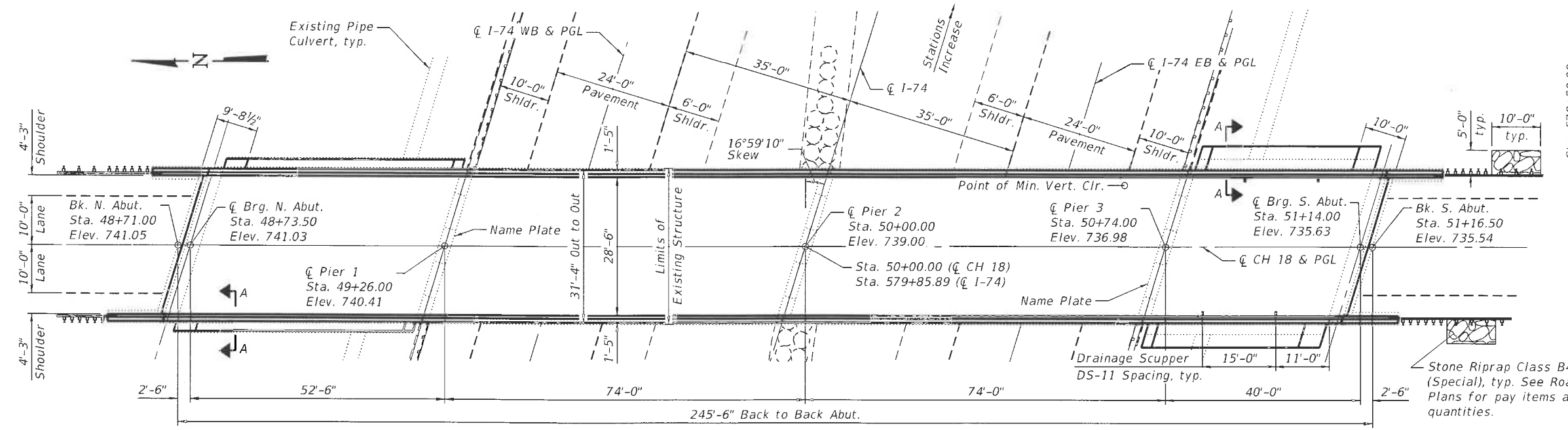
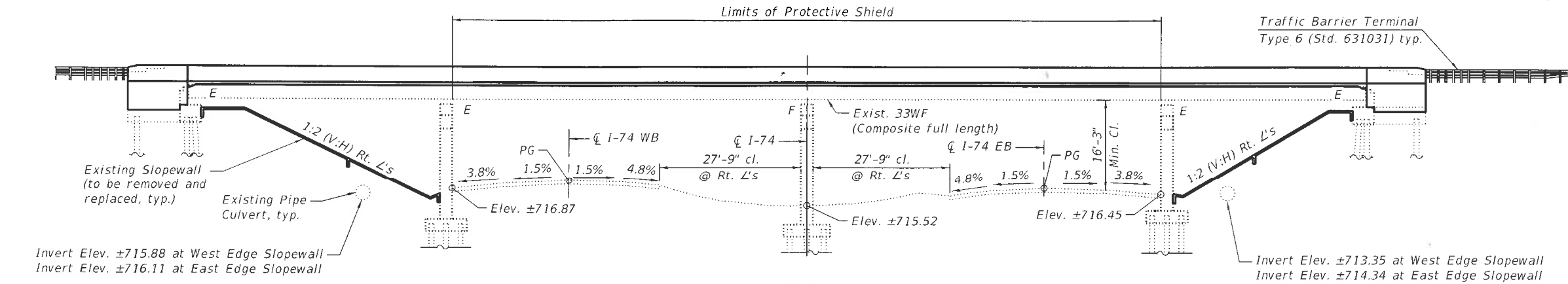

- SCOPE OF WORK**
1. Remove and replace existing concrete deck.
  2. Remove and rebuild upper portion of existing wingwalls.
  3. Remove and replace existing high profile bearings at abutments with elastomeric bearings.
  4. Excavate and place granular backfill behind abutments.
  5. Make existing beams composite full length.
  6. Remove and replace slope walls.

**LOADING HS20-44**  
Allow 25 psf for future wearing surface.

**DESIGN SPECIFICATIONS (NEW CONSTR.)**  
2002 AASHTO Standard Specifications for Highway Bridges, 17th Edition

**APPROVED**  
For Structural Adequacy Only  
Engineer of Bridges & Structures



*Keith W. Bunting* 11/30/2023  
Keith W. Bunting, Illinois S.E. 067-004777 Date  
Expires 11/30/2024

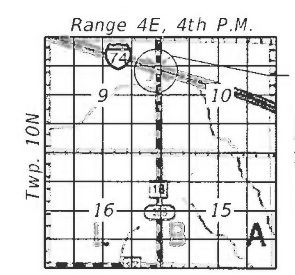

**LOCATION SKETCH**

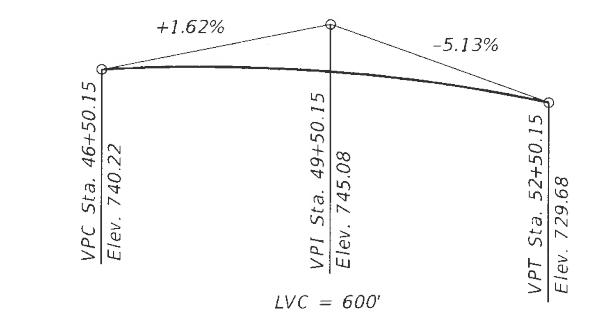

**PROFILE GRADE**  
(Along  $\text{C CH 18}$ )

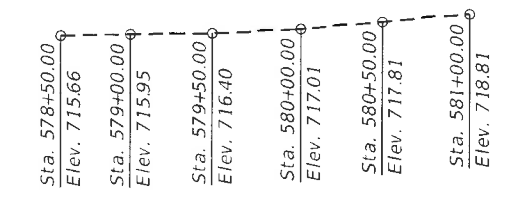

**PROFILE GRADE**  
(Along  $\text{C I-74 EB}$ )

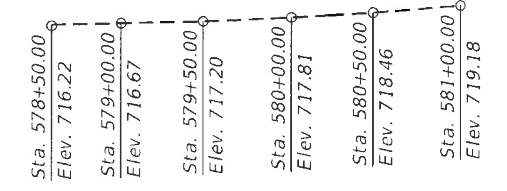

**PROFILE GRADE**  
(Along  $\text{C I-74 WB}$ )

**DESIGN STRESSES**

**FIELD UNITS (Exist. Construction)**  
f'c = 3,500 psi  
fy = 36,000 psi (Structural Steel)  
fy = 40,000 psi (Reinforcement)

**FIELD UNITS (New Construction)**  
f'c = 4,000 psi (Superstructure)  
f'c = 3,500 psi (Substructure)  
fy = 60,000 psi (Reinforcement)  
fy = 36,000 psi (Bearing/Side Retainer)

**SEISMIC DATA**  
Seismic Performance Category (SPC) = A  
Horizontal Bedrock Acceleration Coefficient (A) = 0.04g  
Site Coefficient (S) = 1.5

**GENERAL PLAN & ELEVATION**  
**CH 18 OVER I-74**  
F.A.I. RTE. 74 SEC. [(72-30;48-29)HB-1]BRR  
KNOX COUNTY  
STATION 579+85.89  
STRUCTURE NO. 048-0035

MODEL: Default  
FILE NAME: S:\2022\221008 - PTB 2022-26 - D4 - TMM - Various Ph. I\HWO-2 & 6 CH-18 048-0035\CADD\CADD Sheets\0480035-68D48-001-General Plan Elevation.dgn  
11/30/2023 7:58:01 AM

 QUIGG ENGINEERING INC	USER NAME = kortega	DESIGNED - KFO	REVISED -	STATE OF ILLINOIS DEPARTMENT OF TRANSPORTATION	GENERAL PLAN AND ELEVATION STRUCTURE NO. 048-0035	F.A.I. RTE. 74	SECTION [(72-30;48-29)HB-1]BRR	COUNTY KNOX	TOTAL SHEETS 115	SHEET NO. 88
	PLOT SCALE = 25:0.0000" = 1/4" = 1"	CHECKED - KWB	REVISED -			SHEET 1 OF 17 SHEETS	CONTRACT NO. 68D48			
	PLOT DATE =	DRAWN - JDC	REVISED -			ILLINOIS FED. AID PROJECT				

**GENERAL NOTES**

Fasteners shall be ASTM F 3125 Grade A325 Type 1, mechanically galvanized bolts. Bolts 7/8 in. Ø, holes 1 1/16 in. Ø, unless otherwise noted. No field welding is permitted except as specified in the contract documents. The Contractor shall test the existing welds by non-destructive methods within 2 ft. of the end of the existing cover plates for cracks after removal of the existing concrete deck. Dye penetrant (PT), magnetic particle (MT), or other approved testing method shall be performed by qualified personnel approved by the Engineer. If cracks are found, report them to the Bureau of Bridges and Structures for disposition. The cost of testing is included in Removal of Existing Concrete Deck. The cost of crack repair, if necessary, will be paid for according to Article 109.04 of the Standard Specifications.

Reinforcement bars designated (E) shall be epoxy coated. Prior to pouring the new concrete deck, all heavy or loose rust, loose mill scale, and other loose detrimental foreign material shall be removed from the surfaces in contact with concrete (SSPC - SP3 standards). Tightly adhered paint may remain unless otherwise noted. Removal shall be accomplished by methods that will not damage the steel and the cost will be paid for according to Article 109.04 of the Standard Specifications.

As directed by the Engineer, existing construction accessories welded to the top flange of beams and girders shall be removed. The weld areas shall be ground flush and inspected for cracks using magnetic particle testing (MT) or dye penetrant testing (PT) by qualified personnel approved by the Engineer. Any cracks that cannot be removed by grinding 1/4 in. deep shall be identified and reported to the Bureau of Bridges & Structures for further disposition. The cost of removing welded accessories, grinding and inspecting weld areas and grinding cracks will be paid for according to Article 109.04 of the Standard Specifications.

Plan dimensions and details relative to the existing structure have been taken from existing plans are subject to nominal construction variations. The Contractor shall field verify existing dimensions and details affecting new construction and make necessary approved adjustments prior to construction or ordering of materials. Such variations shall not be cause for additional compensation for a change in scope of the work, however, the Contractor will be paid for the quantity actually furnished at the unit price bid for the work.

Sloped wall shall be reinforced with welded wire fabric, 6" x 6" - W4.0 x W4.0, weighing 58 lbs. per 100 sq. ft. Welded wire fabric shall be galvanized.

New Name Plates shall be located next to the Existing Name Plates on Pier 1 and Pier 3. Cost included with Name Plates.

Granular Backfill behind the abutments shall be compacted according to Article 205.06 of the Standard Specifications.

The existing structural steel coating contains lead. The Contractor shall take appropriate precautions to address the presence of lead on this project.

**INDEX OF SHEETS**

1. General Plan and Elevation
2. General Details
- 3-5. Top of Slab Elevations
6. Superstructure
- 7-8. Superstructure Details
9. Concrete Parapet Slipforming Option
10. Drainage Scuppers, DS-11
11. Framing Plan
12. Design Data Tables
13. Bearing Details
14. North Abutment Removal Details
15. South Abutment Removal Details
16. North Abutment Modification Details
17. South Abutment Modification Details.

STA. 579+85.89  
RE-BUILT 20 BY  
STATE OF ILLINOIS  
F.A.I. RTE. 74  
SEC. [(72-30;48-29)HB-1]BRR  
LOADING HS20-44  
STR. NO. 048-0035

**NAME PLATE**  
See Std. 515001

**TOTAL BILL OF MATERIAL**

ITEM	UNIT	SUPER	SUB	TOTAL
Concrete Removal	Cu. Yd.		17.1	17.1
Slope Wall Removal	Sq. Yd.		378	378
Removal of Existing Concrete Deck No. 2	Each	1		1
Protective Shield	Sq. Yd.	527		527
Structure Excavation	Cu. Yd.		109	109
Concrete Structures	Cu. Yd.		15.4	15.4
Concrete Superstructure	Cu. Yd.	276.3		276.3
Bridge Deck Grooving	Sq. Yd.	718		718
Protective Coat	Sq. Yd.	1,014		1,014
Furnishing & Erecting Structural Steel	Pound		1,540	1,540
Stud Shear Connectors	Each	3,345		3,345
Reinforcement Bars, Epoxy Coated	Pound	70,480	2,450	72,930
Slope Wall 4 Inch	Sq. Yd.		410	410
Name Plates	Each	2		2
Elastomeric Bearing Assembly, Type 1	Each		10	10
Anchor Bolts, 5/8"	Each		40	40
Granular Backfill for Structures	Cu. Yd.		94	94
Geocomposite Wall Drain	Sq. Yd.		53	53
Pipe Underdrains for Structures 4"	Foot		127	127
Jack and Remove Existing Bearings	Each		10	10
Drainage Scuppers, DS-11	Each	4		4

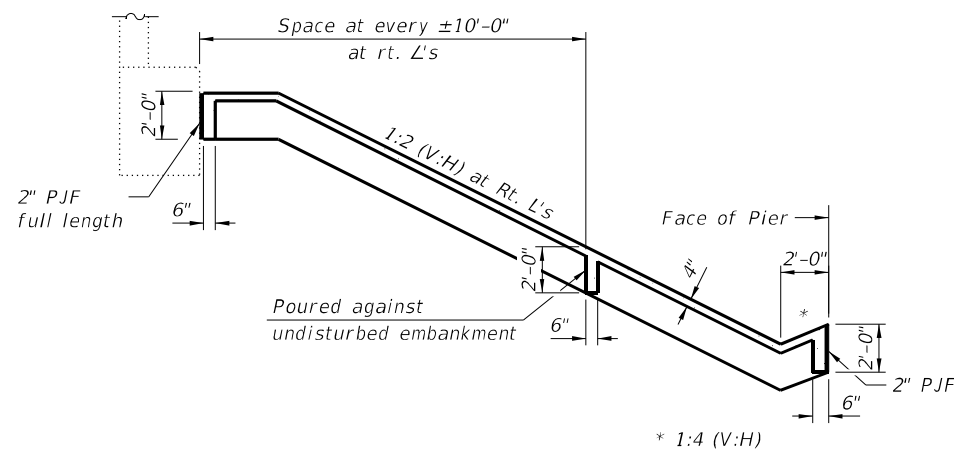

**SECTION THRU CONCRETE SLOPEWALL**

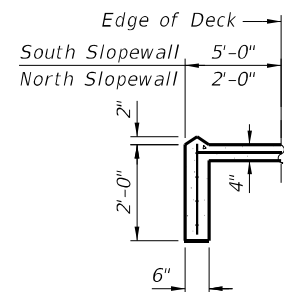

**SECTION A-A**

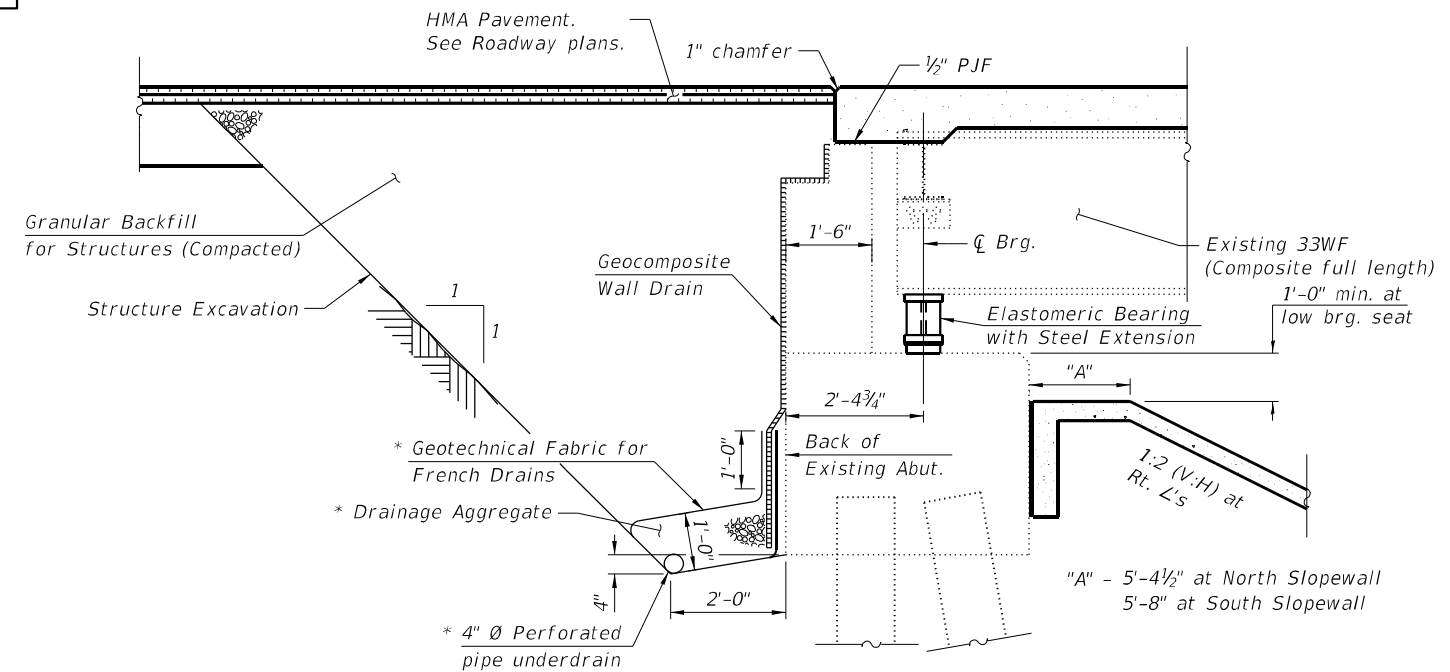

**SECTION THRU ABUTMENT**  
(Horiz. dim. @ Rt. L's)

\* Included in the cost of Pipe Underdrains for Structures.

**Note:**

All drainage system components shall extend parallel to the abutment back wall until they intersect the wingwalls. The pipe shall extend under the wingwall, if necessary, until intersecting the side slopes. The pipes shall drain into concrete headwalls. (See Article 601.05 of the Standard Specifications and Highway Standard 601101).

MODEL: Default  
FILE NAME: S:\2022\2121008 - PTB 202-26 - D4 - TMM - Various Ph I-II\WC-2 & 6 CH-18 048-0035\CADD\CADD Sheets\0480035-68D48-002-General Details.dgn  
11/30/2023 7:58:33 AM



USER NAME = kortega	DESIGNED - KFO	REVISED -
0480035-68D48-002-General Details.dgn	CHECKED - KWB	REVISED -
PLOT SCALE = 3:4.0000 "/> <td>DRAWN - JDC</td> <td>REVISED -</td>	DRAWN - JDC	REVISED -
PLOT DATE =	CHECKED - MDC	REVISED -

**STATE OF ILLINOIS  
DEPARTMENT OF TRANSPORTATION**

**GENERAL DETAILS  
STRUCTURE NO. 048-0035**

SHEET 2 OF 17 SHEETS

F.A.I. RTE. 74	SECTION [(72-30;48-29)HB-1]BRR	COUNTY KNOX	TOTAL SHEETS 115	SHEET NO. 89
CONTRACT NO. 68D48				
ILLINOIS		FED. AID PROJECT		

MODEL: Default  
 FILE NAME: S:\2022\212L008 - PTB 202-26 - D4 - TMM - Various Ph I\IWO-2 & 6 CH-18 048-0035\CADD\CADD Sheets\0480035-68D48-003-Top of Slab Elevations.dgn

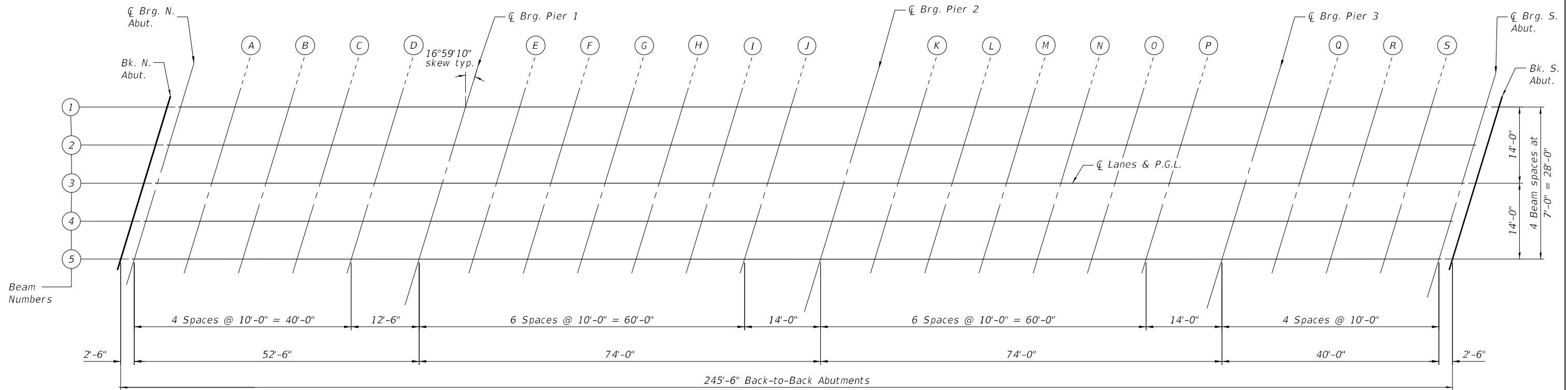

PLAN

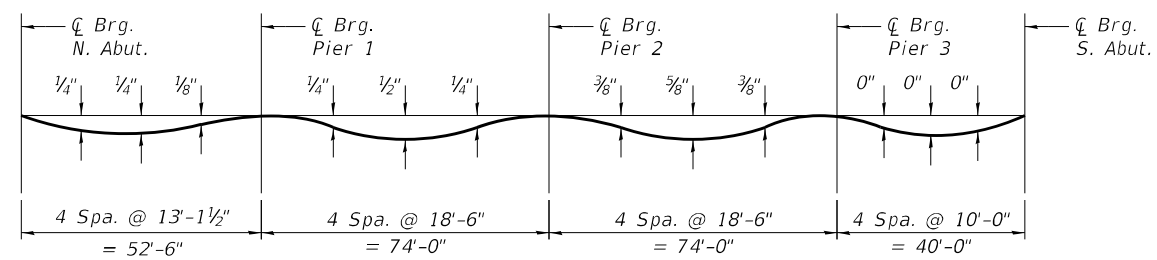
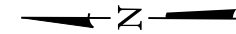

DEAD LOAD DEFLECTION DIAGRAM

(Includes weight of concrete only.)

Note:

The above deflections are not to be used in the field if the engineer is working from the grade elevations adjusted for dead load deflections as shown on sheet 4 and 5 of 17.

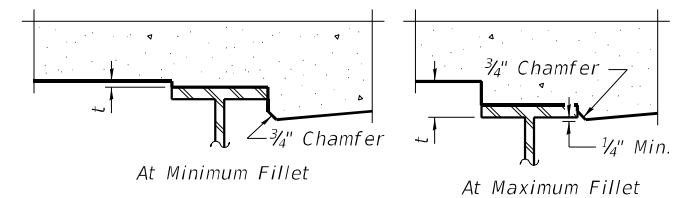

To determine "t": After all structural steel has been erected, elevations of the top flanges of the beams shall be taken at intervals shown on this sheet. These elevations subtracted from the "Theoretical Grade Elevations Adjusted for Dead Load Deflection" shown on Sheets 4 and 5 of 17, minus slab thickness, equals the fillet heights "t" above top flange of beams.

FILLET HEIGHTS



USER NAME = JCray	DESIGNED - KFO	REVISED -
0480035-68D48-003-Top of Slab Elevations.dgn	CHECKED - KWB	REVISED -
PLOT SCALE = 18:4.0000 '":' / in.	DRAWN - JDC	REVISED -
PLOT DATE =	CHECKED - MDC	REVISED -

STATE OF ILLINOIS  
 DEPARTMENT OF TRANSPORTATION

TOP OF SLAB ELEVATIONS (1 OF 3)  
 STRUCTURE NO. 048-0035

SHEET 3 OF 17 SHEETS

F.A.I. RTE.	SECTION	COUNTY	TOTAL SHEETS	SHEET NO.
74	[(72-30;48-29)HB-1]BR	KNOX	115	90
CONTRACT NO. 68D48				
ILLINOIS FED. AID PROJECT				

GIRDER 1

Location	Station	Offset (ft.)	Theoretical Grade Elevations	Elevations Adjusted for Dead Load Deflections
Bk. North Abut.	48+75.28	-14.00	740.78	740.78
☒ Brg - North Abut.	48+77.78	-14.00	740.76	740.76
A	48+87.78	-14.00	740.66	740.67
B	48+97.78	-14.00	740.55	740.57
C	49+07.78	-14.00	740.43	740.44
D	49+17.78	-14.00	740.29	740.30
☒ Brg. Pier 1	49+30.28	-14.00	740.11	740.11
E	49+40.28	-14.00	739.95	739.96
F	49+50.28	-14.00	739.78	739.80
G	49+60.28	-14.00	739.60	739.63
H	49+70.28	-14.00	739.41	739.44
I	49+80.28	-14.00	739.20	739.23
J	49+90.28	-14.00	738.99	739.00
☒ Brg. Pier 2	50+04.28	-14.00	738.67	738.67
K	50+14.28	-14.00	738.43	738.44
L	50+24.28	-14.00	738.17	738.20
M	50+34.28	-14.00	737.91	737.95
N	50+44.28	-14.00	737.63	737.67
O	50+54.28	-14.00	737.35	737.38
P	50+64.28	-14.00	737.05	737.07
☒ Brg. Pier 3	50+78.28	-14.00	736.61	736.61
Q	50+88.28	-14.00	736.28	736.28
R	50+98.28	-14.00	735.95	735.95
S	51+08.28	-14.00	735.60	735.60
☒ Brg. - South Abut.	51+18.28	-14.00	735.24	735.24
Bk. South Abut.	51+20.78	-14.00	735.15	735.15

GIRDER 2

Location	Station	Offset (ft.)	Theoretical Grade Elevations	Theoretical Grade Elevations Adjusted for Dead Load Deflections
Bk. North Abut.	48+73.14	-7.00	740.93	740.93
☒ Brg - North Abut.	48+75.64	-7.00	740.91	740.91
A	48+85.64	-7.00	740.81	740.82
B	48+95.64	-7.00	740.70	740.72
C	49+05.64	-7.00	740.58	740.60
D	49+15.64	-7.00	740.45	740.45
☒ Brg. Pier 1	49+28.14	-7.00	740.27	740.27
E	49+38.14	-7.00	740.11	740.12
F	49+48.14	-7.00	739.94	739.97
G	49+58.14	-7.00	739.77	739.81
H	49+68.14	-7.00	739.58	739.62
I	49+78.14	-7.00	739.37	739.40
J	49+88.14	-7.00	739.16	739.17
☒ Brg. Pier 2	50+02.14	-7.00	738.84	738.84
K	50+12.14	-7.00	738.60	738.62
L	50+22.14	-7.00	738.35	738.38
M	50+32.14	-7.00	738.09	738.14
N	50+42.14	-7.00	737.82	737.87
O	50+52.14	-7.00	737.53	737.58
P	50+62.14	-7.00	737.24	737.26
☒ Brg. Pier 3	50+76.14	-7.00	736.80	736.80
Q	50+86.14	-7.00	736.48	736.48
R	50+96.14	-7.00	736.15	736.14
S	51+06.14	-7.00	735.80	735.80
☒ Brg. - South Abut.	51+16.14	-7.00	735.44	735.44
Bk. South Abut.	51+18.64	-7.00	735.35	735.35

GIRDER 3, ☒ LANES & P.G.L.

Location	Station	Offset (ft.)	Theoretical Grade Elevations	Theoretical Grade Elevations Adjusted for Dead Load Deflections
Bk. North Abut.	48+71.00	0.00	741.05	741.05
☒ Brg - North Abut.	48+73.50	0.00	741.03	741.03
A	48+83.50	0.00	740.93	740.95
B	48+93.50	0.00	740.83	740.85
C	49+03.50	0.00	740.71	740.73
D	49+13.50	0.00	740.58	740.59
☒ Brg. Pier 1	49+26.00	0.00	740.41	740.41
E	49+36.00	0.00	740.25	740.26
F	49+46.00	0.00	740.09	740.11
G	49+56.00	0.00	739.91	739.95
H	49+66.00	0.00	739.72	739.76
I	49+76.00	0.00	739.52	739.55
J	49+86.00	0.00	739.31	739.33
☒ Brg. Pier 2	50+00.00	0.00	739.00	739.00
K	50+10.00	0.00	738.76	738.77
L	50+20.00	0.00	738.51	738.54
M	50+30.00	0.00	738.25	738.30
N	50+40.00	0.00	737.98	738.04
O	50+50.00	0.00	737.70	737.74
P	50+60.00	0.00	737.41	737.43
☒ Brg. Pier 3	50+74.00	0.00	736.98	736.98
Q	50+84.00	0.00	736.66	736.65
R	50+94.00	0.00	736.32	736.32
S	51+04.00	0.00	735.98	735.98
☒ Brg. - South Abut.	51+14.00	0.00	735.63	735.63
Bk. South Abut.	51+16.50	0.00	735.54	735.54

Notes:  
Stations are measured along ☒ CH 18.  
Offsets are measured from P.G.L.

MODEL: Default  
FILE NAME: S:\2022\2121008 - PTB 202-26 - D4 - TMM - Various Ph I-II\WC-2 & 6 CH-18 048-0035\CADD\CADD Sheets\0480035-68D48-004-Top of Slab Elevations.dgn  
10/2/2023 1:27:41 PM



USER NAME = JCray	DESIGNED - KFO	REVISED -
0480035-68D48-004-Top of Slab Elevations.dgn	CHECKED - KWB	REVISED -
PLOT SCALE = 0:2.0000 " = 1/8"	DRAWN - JDC	REVISED -
PLOT DATE =	CHECKED - MDC	REVISED -

STATE OF ILLINOIS  
DEPARTMENT OF TRANSPORTATION

TOP OF SLAB ELEVATIONS (2 OF 3)  
STRUCTURE NO. 048-0035

SHEET 4 OF 17 SHEETS

F.A.I. RTE.	SECTION	COUNTY	TOTAL SHEETS	SHEET NO.
74	[(72-30;48-29)HB-1]BRR	KNOX	115	91
CONTRACT NO. 68D48				
ILLINOIS		FED. AID PROJECT		

GIRDER 4

Location	Station	Offset (ft.)	Theoretical Grade Elevations	Theoretical Grade Elevations Adjusted for Dead Load Deflections
Bk. North Abut.	48+68.86	7.00	740.96	740.96
☒ Brg - North Abut.	48+71.36	7.00	740.94	740.94
A	48+81.36	7.00	740.85	740.87
B	48+91.36	7.00	740.75	740.77
C	49+01.36	7.00	740.63	740.65
D	49+11.36	7.00	740.51	740.51
☒ Brg. Pier 1	49+23.86	7.00	740.33	740.33
E	49+33.86	7.00	740.18	740.19
F	49+43.86	7.00	740.02	740.05
G	49+53.86	7.00	739.84	739.88
H	49+63.86	7.00	739.66	739.70
I	49+73.86	7.00	739.46	739.49
J	49+83.86	7.00	739.25	739.27
☒ Brg. Pier 2	49+97.86	7.00	738.94	738.94
K	50+07.86	7.00	738.71	738.72
L	50+17.86	7.00	738.46	738.49
M	50+27.86	7.00	738.20	738.25
N	50+37.86	7.00	737.94	737.99
O	50+47.86	7.00	737.66	737.70
P	50+57.86	7.00	737.36	737.39
☒ Brg. Pier 3	50+71.86	7.00	736.94	736.94
Q	50+81.86	7.00	736.62	736.62
R	50+91.86	7.00	736.29	736.29
S	51+01.86	7.00	735.95	735.95
☒ Brg. - South Abut.	51+11.86	7.00	735.60	735.60
Bk. South Abut.	51+14.36	7.00	735.51	735.51

GIRDER 5

Location	Station	Offset (ft.)	Theoretical Grade Elevations	Theoretical Grade Elevations Adjusted for Dead Load Deflections
Bk. North Abut.	48+66.72	14.00	740.86	740.86
☒ Brg - North Abut.	48+69.22	14.00	740.84	740.84
A	48+79.22	14.00	740.75	740.76
B	48+89.22	14.00	740.65	740.66
C	48+99.22	14.00	740.53	740.55
D	49+09.22	14.00	740.41	740.41
☒ Brg. Pier 1	49+21.72	14.00	740.24	740.24
E	49+31.72	14.00	740.09	740.10
F	49+41.72	14.00	739.93	739.95
G	49+51.72	14.00	739.76	739.79
H	49+61.72	14.00	739.57	739.61
I	49+71.72	14.00	739.38	739.40
J	49+81.72	14.00	739.17	739.18
☒ Brg. Pier 2	49+95.72	14.00	738.87	738.87
K	50+05.72	14.00	738.63	738.64
L	50+15.72	14.00	738.39	738.41
M	50+25.72	14.00	738.14	738.17
N	50+35.72	14.00	737.87	737.91
O	50+45.72	14.00	737.59	737.63
P	50+55.72	14.00	737.30	737.32
☒ Brg. Pier 3	50+69.72	14.00	736.88	736.88
Q	50+79.72	14.00	736.56	736.56
R	50+89.72	14.00	736.24	736.24
S	50+99.72	14.00	735.90	735.90
☒ Brg. - South Abut.	51+09.72	14.00	735.55	735.55
Bk. South Abut.	51+12.22	14.00	735.46	735.46

Notes:  
 Stations are measured along ☒ CH 18.  
 Offsets are measured from P.G.L.

MODEL: Default  
 FILE NAME: S:\2022\2121008 - PTB 202-26 - D4 - TMM - Various Ph I-IWOC-2 & 6 CH-18 048-0035\CADD\CADD Sheets\0480035-68D48-005-Top of Slab Elevations.dgn  
 10/2/2023 1:27:49 PM



USER NAME = JCray	DESIGNED - KFO	REVISED -
0480035-68D48-005-Top of Slab Elevations.dgn	CHECKED - KWB	REVISED -
PLOT SCALE = 0:2.0000 " = 1/ in.	DRAWN - JDC	REVISED -
PLOT DATE =	CHECKED - MDC	REVISED -

STATE OF ILLINOIS  
 DEPARTMENT OF TRANSPORTATION

TOP OF SLAB ELEVATIONS (3 OF 3)  
 STRUCTURE NO. 048-0035

SHEET 5 OF 17 SHEETS

F.A.I. RTE.	SECTION	COUNTY	TOTAL SHEETS	SHEET NO.
74	[(72-30;48-29)HB-1]BRR	KNOX	115	92
CONTRACT NO. 68D48				
ILLINOIS		FED. AID PROJECT		

MODEL: Default  
 FILE NAME: S:\2022\2121008 - PTB 202-26 - D4 - TMM - Various Ph I\IWO-2 & 6 CH-18 048-0035\CADD\CADD Sheets\0480035-68D48-006-Superstructure.dgn  
 10/2/2023 1:27:59 PM

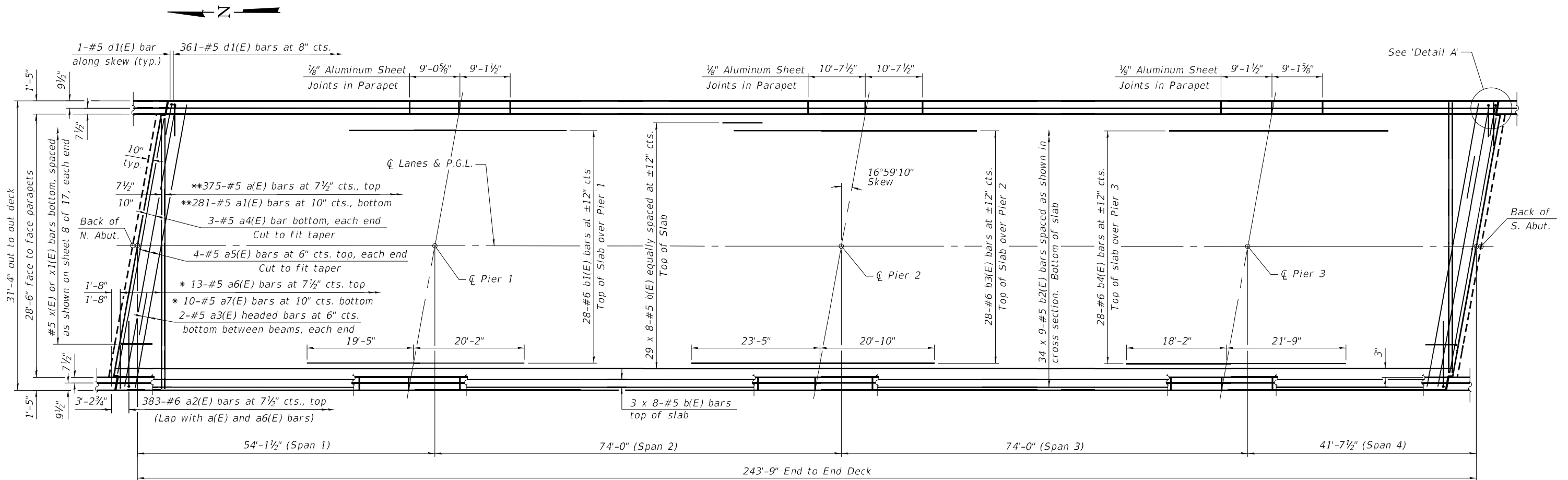

**MINIMUM BAR LAP**  
 #5 bar = 3'-6"

**PLAN**

\* See Field Cutting Diagram on sheet 8 of 17.  
 \*\* Cut first and last bar to fit tapered portion of deck.

**Notes:**  
 See sheet 7 of 17 for superstructure details and Bill of Material.  
 Bars indicated thus 20 x 3-#5 etc. indicated 20 lines of bars with 3 lengths per line.

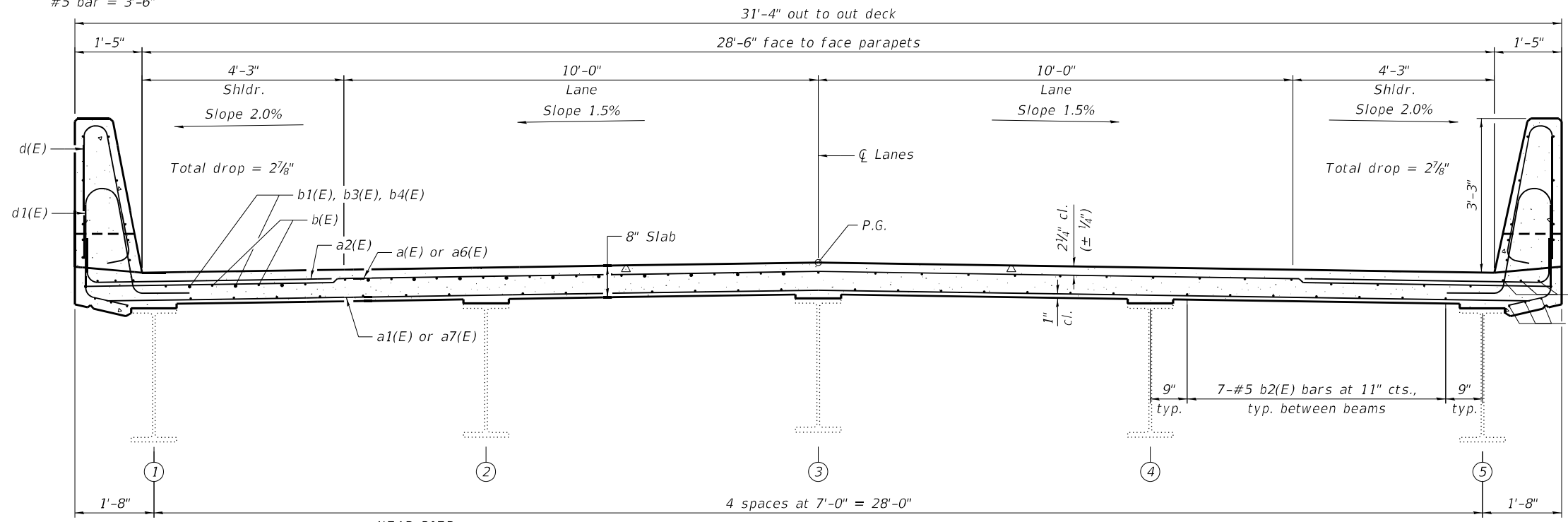

**CROSS SECTION**  
 (Looking South)

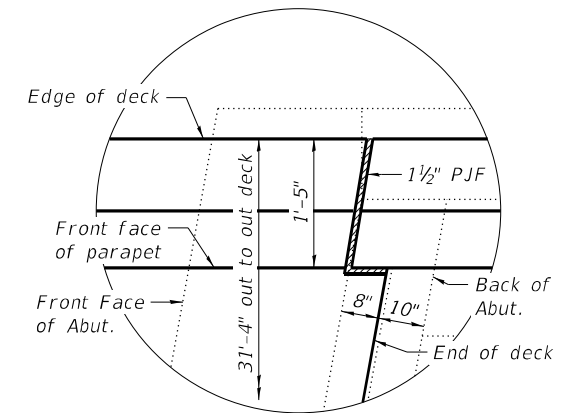

**DETAIL A**  
 (Reinforcement not shown for clarity)



USER NAME = JCray	DESIGNED - KFO	REVISED -
0480035-68D48-006-Superstructure.dgn	CHECKED - KWB	REVISED -
PLOT SCALE = 20:0.0000' : 1 in.	DRAWN - JDC	REVISED -
PLOT DATE =	CHECKED - MDC	REVISED -

**STATE OF ILLINOIS**  
**DEPARTMENT OF TRANSPORTATION**

**SUPERSTRUCTURE**  
**STRUCTURE NO. 048-0035**

SHEET 6 OF 17 SHEETS

F.A.I. RTE.	SECTION	COUNTY	TOTAL SHEETS	SHEET NO.
74	[(72-30;48-29)H8-1]BR	KNOX	115	93
CONTRACT NO. 68D48				
ILLINOIS		FED. AID PROJECT		

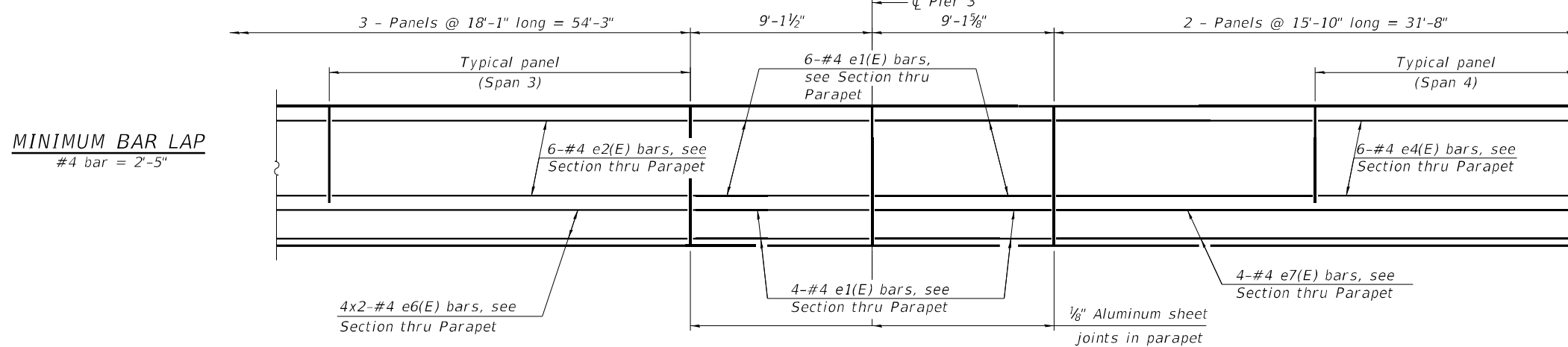
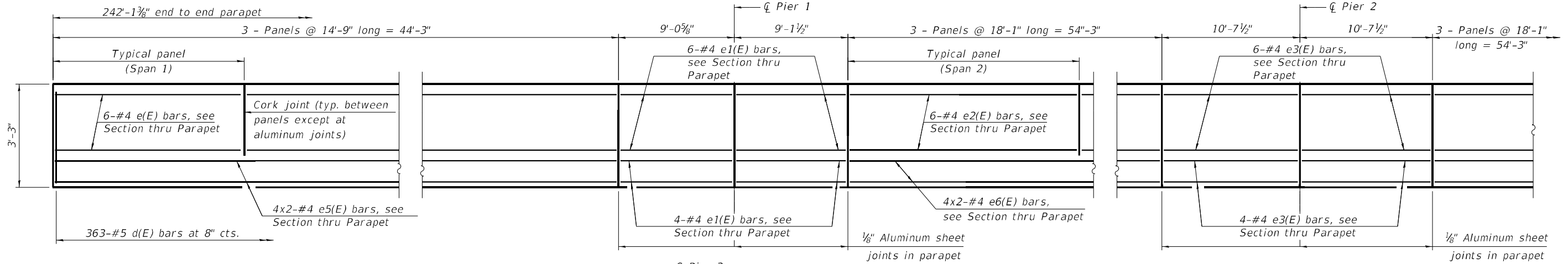

**MINIMUM BAR LAP**  
#4 bar = 2'-5"

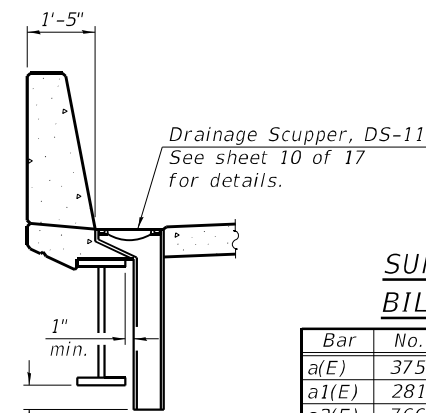

**SUPERSTRUCTURE BILL OF MATERIAL**

Bar	No.	Size	Length	Shape
a(E)	375	#5	31'-0"	—
a1(E)	281	#5	30'-8"	—
a2(E)	766	#6	8'-4"	—
a3(E)	16	#5	7'-0"	—
a4(E)	6	#5	32'-0"	—
a5(E)	8	#5	32'-4"	—
a6(E)	13	#5	33'-11"	—
a7(E)	10	#5	33'-7"	—
a8(E)	32	#5	1'-6"	—
b(E)	280	#5	33'-6"	—
b1(E)	28	#6	39'-7"	—
b2(E)	306	#5	30'-2"	—
b3(E)	28	#6	44'-3"	—
b4(E)	28	#6	39'-11"	—
d(E)	732	#5	6'-5"	—
d1(E)	732	#5	7'-0"	—
e(E)	36	#4	14'-5"	—
e1(E)	80	#4	8'-8"	—
e2(E)	72	#4	17'-9"	—
e3(E)	40	#4	10'-3"	—
e4(E)	24	#4	15'-6"	—
e5(E)	16	#4	23'-2"	—
e6(E)	32	#4	28'-2"	—
e7(E)	8	#4	31'-4"	—
x(E)	18	#5	5'-1"	—
x1(E)	30	#5	5'-6"	—
Reinforcement Bars, Epoxy Coated		Pound	70,480	
Concrete Superstructure		Cu. Yd.	276.3	

**INSIDE ELEVATION OF PARAPET**

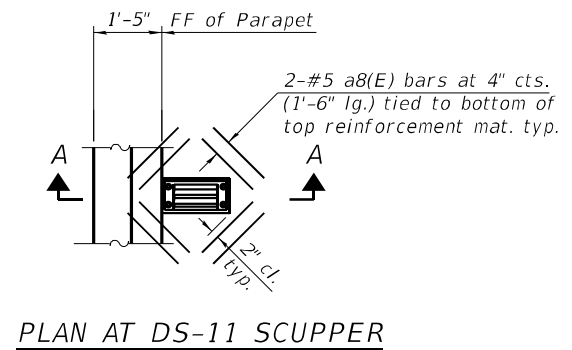
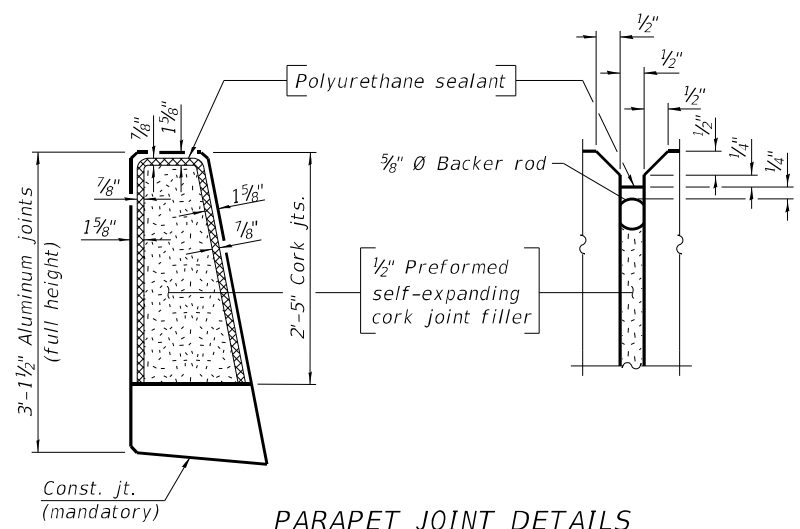

Note:  
Cut longitudinal reinforcement to clear drainage scuppers.

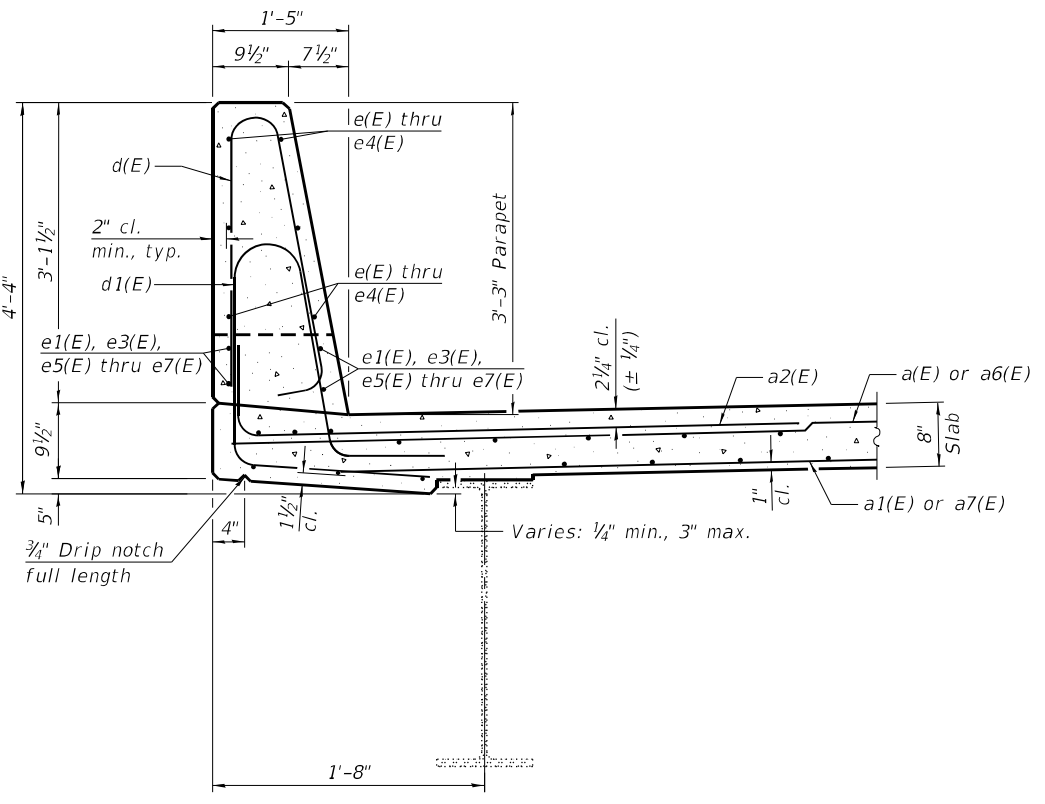

Notes:  
The 1/8" Aluminum sheet shall be ASTM B 209 alloy 3003-H14 and coated to minimize reaction with wet concrete. Cost included with Concrete Superstructure.  
The Polyurethane Sealant shall be according to Article 1050.04 of the Std. Spec. and the color shall be gray.  
Headed bars shall conform to ASTM A970 with threaded attachment; Class HA; and reinforcement bars conforming to ASTM A706. Cost included with Reinforcement Bars, Epoxy Coated.  
See sheet 8 of 17 for additional superstructure details.

Bars indicated thus 1 x 2-#4 etc. indicates 1 line of bars with 2 lengths per line.

MODEL: Default  
FILE NAME: S:\2022\212L008 - PTB 202-26 - D4 - TMM - Various Ph I\IWC-2 & 6 CH-18 048-0035\CADD\CADD Sheets\0480035-68D48-007-Superstructure Details.dgn  
10/2/2023 1:28:08 PM



USER NAME = JCray	DESIGNED - KFO	REVISED -
0480035-68D48-007-Superstructure Details.dgn	CHECKED - KWB	REVISED -
PLOT SCALE = 0:2.0000 "/>		
PLOT DATE =	CHECKED - MDC	REVISED -

**STATE OF ILLINOIS**  
**DEPARTMENT OF TRANSPORTATION**

**SUPERSTRUCTURE DETAILS (1 OF 2)**  
**STREET NO. 048-0035**

SHEET 7 OF 17 SHEETS

F.A.I. RTE.	SECTION	COUNTY	TOTAL SHEETS	SHEET NO.
74	[(72-30;48-29)H8-1]BRR	KNOX	115	94
CONTRACT NO. 68D48				
ILLINOIS FED. AID PROJECT				

MODEL: Default  
 FILE NAME: S:\2022\2121008 - PTB 202-26 - D4 - TMM - Various Ph I-II\WC-2 & 6 CH-18 048-0035\CADD\CADD Sheets\0480035-68D48-008-Superstructure Details.dgn  
 10/2/2023 1:28:17 PM

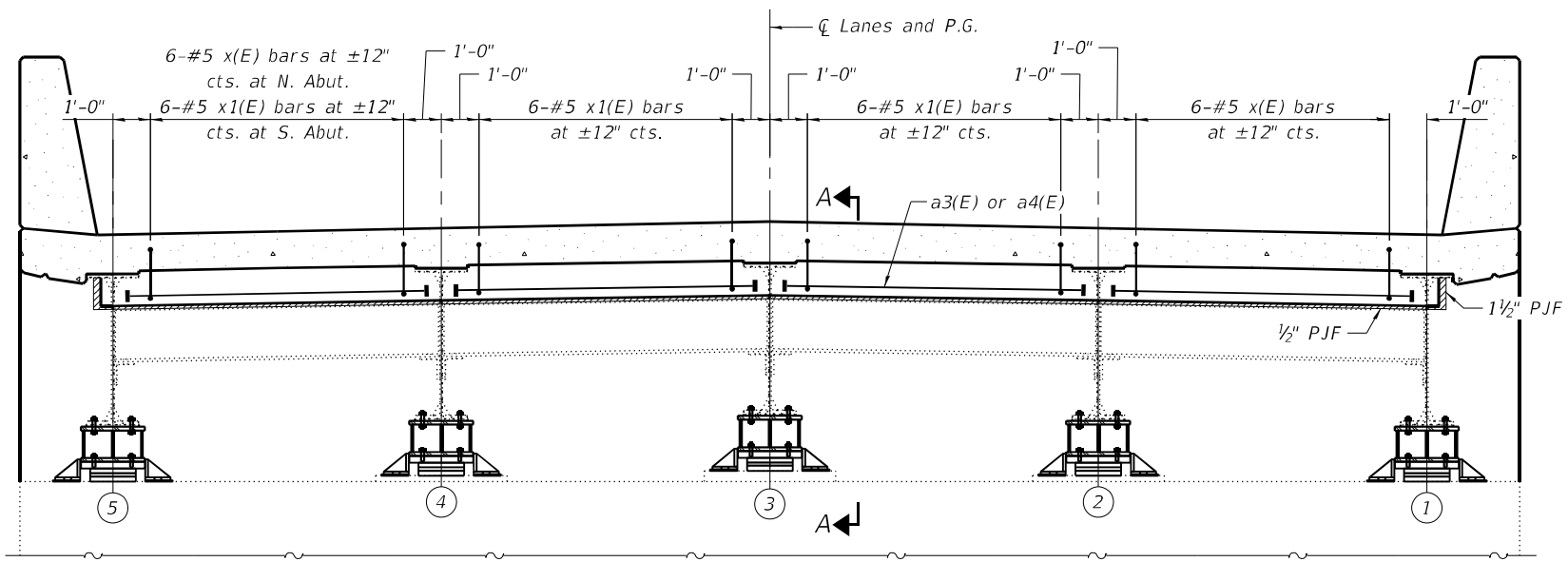

**DIAPHRAGM AT ABUTMENT**  
 (Looking North at North Abutment, South Abutment Similar U.N.O.)

**Notes:**  
 See sheet 7 of 17 for additional superstructure details and Bill of Material.  
 The x(E) and x1(E) bars shall be placed parallel to the beams. Spacing for these bars shall be at right angles to the beams.

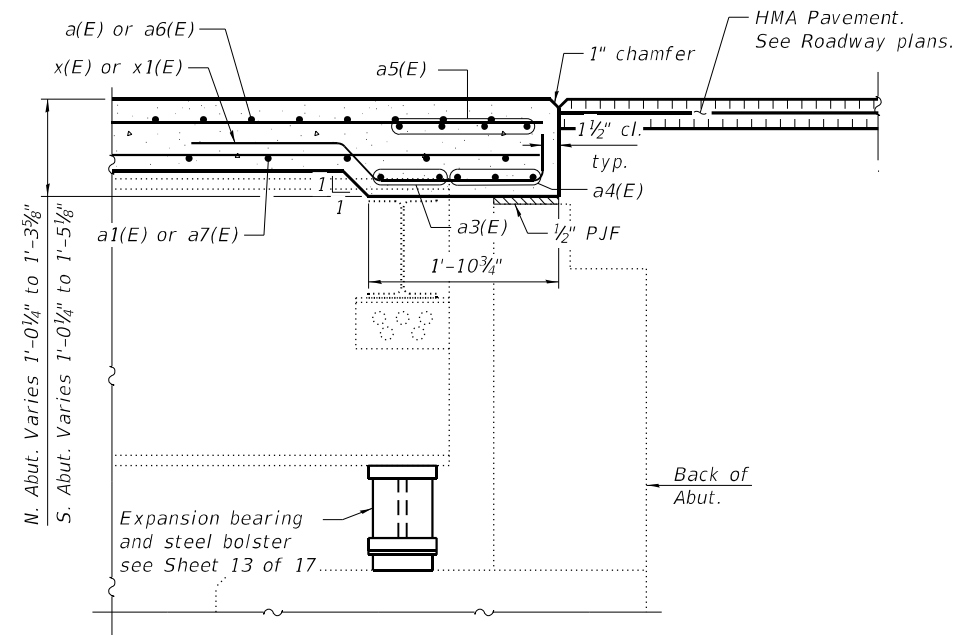

**SECTION A-A**  
 (at Rt. L's)

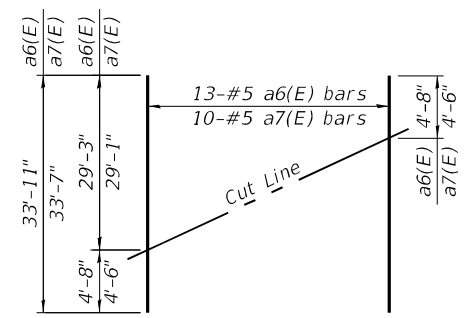

**FIELD CUTTING DIAGRAM**  
 Order a6(E) and a7(E) bars full length.  
 Cut as shown and use remainder of bars in opposite end of deck.

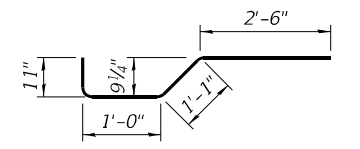
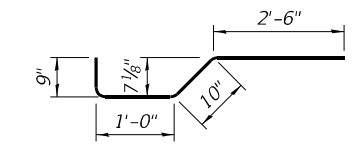
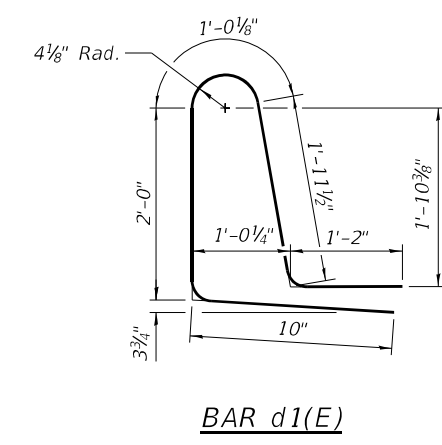
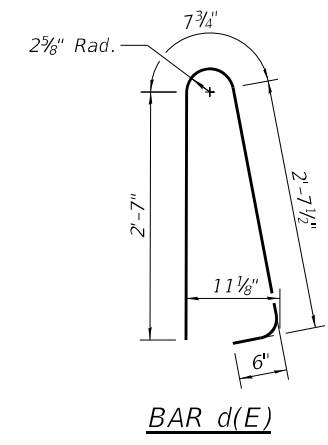
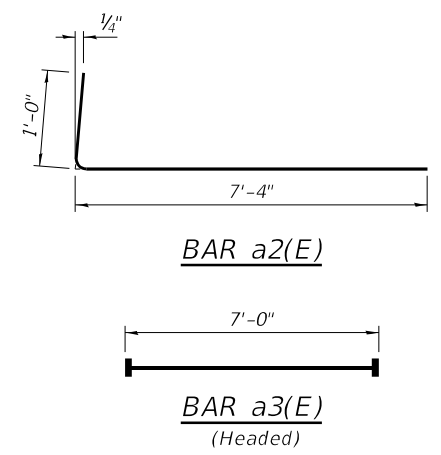

USER NAME = JCray	DESIGNED - KFO	REVISED -
0480035-68D48-008-Superstructure Details.dgn	CHECKED - KWB	REVISED -
PLOT SCALE = 0:2.0000 "/> <td>DRAWN - JDC</td> <td>REVISED -</td>	DRAWN - JDC	REVISED -
PLOT DATE =	CHECKED - MDC	REVISED -

**STATE OF ILLINOIS**  
**DEPARTMENT OF TRANSPORTATION**

**SUPERSTRUCTURE DETAILS (2 OF 2)**  
**STRUCTURE NO. 048-0035**

SHEET 8 OF 17 SHEETS

F.A.I. RTE. 74	SECTION [(72-30/48-29)HB-1]BRR	COUNTY KNOX	TOTAL SHEETS 115	SHEET NO. 95
CONTRACT NO. 68D48				
ILLINOIS FED. AID PROJECT				



MODEL: Default  
 FILE NAME: S:\2022\2121008 - PTB 202-26 - D4 - TMM - Various Ph I-11WOC-2 & 6 CH-18 048-0035\CADD\CADD Sheets\0480035-68D48-009-Para\_Slipform Op..dgn  
 10/2/2023 1:28:26 PM

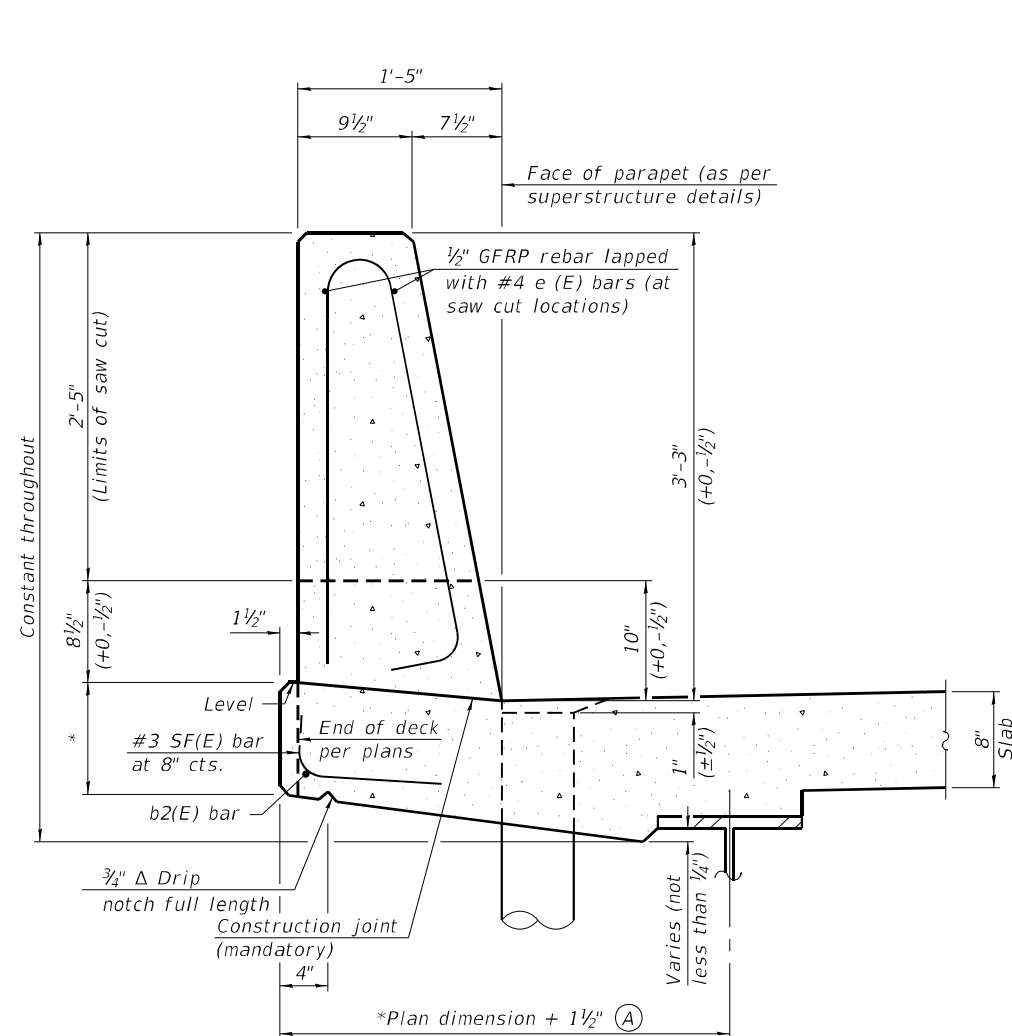

**39" CONSTANT-SLOPE  
 PARAPET SECTION**

(Showing dimensions, d(E), and 1/2" Ø GFRP rebar)

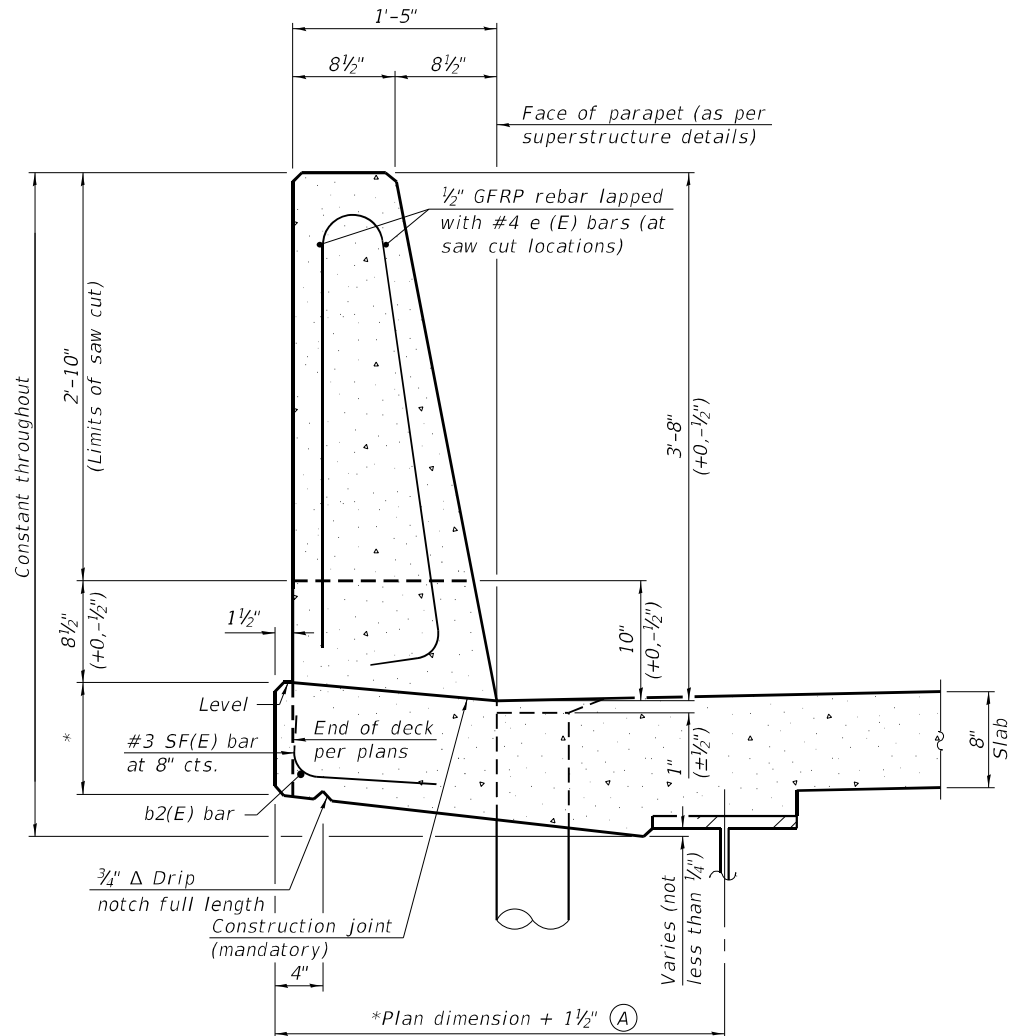

**44" CONSTANT-SLOPE  
 PARAPET SECTION**

(Showing dimensions, d(E), and 1/2" Ø GFRP rebar)

\*See Superstructure Details.

Notes:  
 All dimensions shall remain the same as shown on superstructure details, except dimension A which is to be revised as shown. Additional concrete needed to revise dimension A = 0.00348 cu. yds./ft. for 39" and 44" parapets.  
 Place full depth aluminum sheets as shown on superstructure details.  
 Replace all cork joint filler locations with a full thickness saw cut.  
 Steel superstructure shown. Other superstructure types similar.

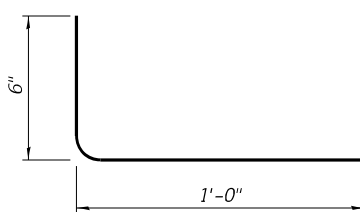

**SF(E) BAR**

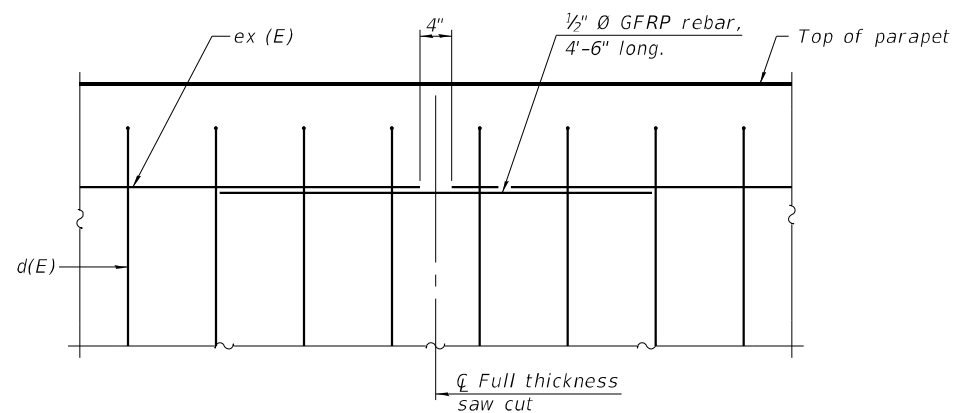

**GFRP REBAR STIFFENING DETAIL**

(Place as shown in parapet section at each parapet joint location.)

SFP 39-44

11-1-2022



USER NAME = JCray	DESIGNED - KFO	REVISED -
0480035-68D48-009-Para_Slipform Op..dgn	CHECKED - KWB	REVISED -
PLOT SCALE = 0:2.0000 '"/in.	DRAWN - JDC	REVISED -
PLOT DATE =	CHECKED - MDC	REVISED -

STATE OF ILLINOIS  
 DEPARTMENT OF TRANSPORTATION

CONCRETE PARAPET SLIPFORMING OPTION  
 STRUCTURE NO. 048-0035

SHEET 9 OF 17 SHEETS

F.A.I. RTE.	SECTION	COUNTY	TOTAL SHEETS	SHEET NO.
74	[(72-30;48-29)HB-1]BR	KNOX	115	96
CONTRACT NO. 68D48				

ILLINOIS FED. AID PROJECT

MODEL: Default  
 FILE NAME: S:\2022\2121008 - PTB 202-26 - D4 - TMM - Various Ph I-11WOC-2 & 6 CH-18 048-0035\CADD\CADD Sheets\0480035-68D48-010-Drainage Scuppers DS-11.dgn  
 10/2/2023 1:28:35 PM

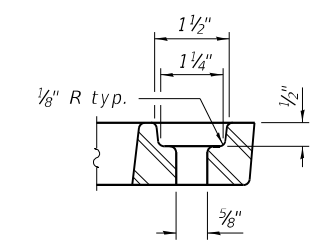
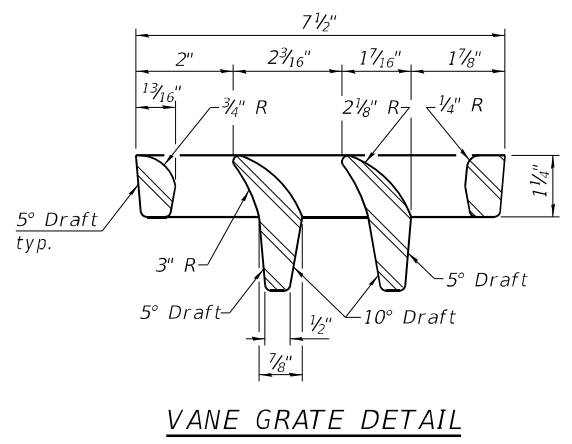
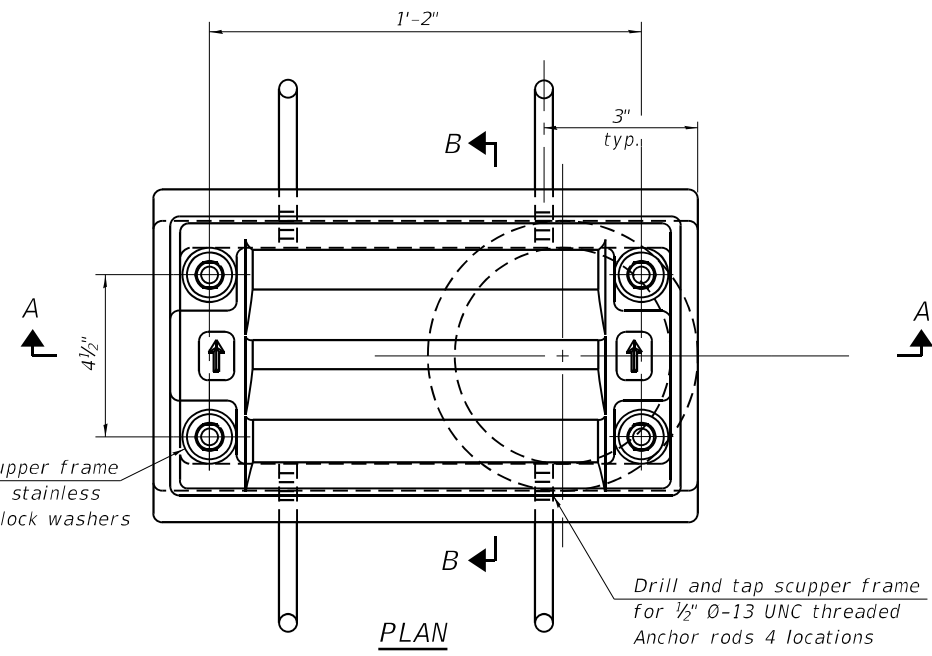

**Notes:**  
 All cast iron parts shall be gray iron conforming to the requirements of AASHTO M105, Class 35B and AASHTO M306.  
 Bolts, anchor rods, nuts and washers shall be according to ASTM A307 and shall be galvanized according to AASHTO M232. As an alternate stainless steel may be used.  
 Stainless steel hardware shall be according to Article 1006.29(d) of the Standard Specifications.  
 Structural steel weldments of equal sections and of the same configuration may be substituted for the cast iron scupper frames and downspouts; however, the scupper grates shall remain cast iron. Fillet or full penetration welds shall be used for the weldments. Details shall be submitted to the Engineer for approval.  
 Structural steel scupper frames and downspouts, when utilized, shall be galvanized according to AASHTO M111.  
 As an alternate, fiberglass may be used for downspouts according to ASTM D2996 with a short-time rupture strength hoop tensile stress of 30,000 psi min. in lieu of the cast iron or structural steel.  
 The Contractor shall take appropriate measures to assure that Protective Coat is not applied to the scupper.  
 Cost of the grate, frame, downspout, anchor rods, nuts and washers including complete installation of the scupper shall be paid for at the contract unit price for Drainage Scuppers, DS-11.

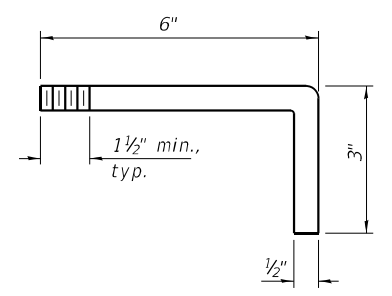
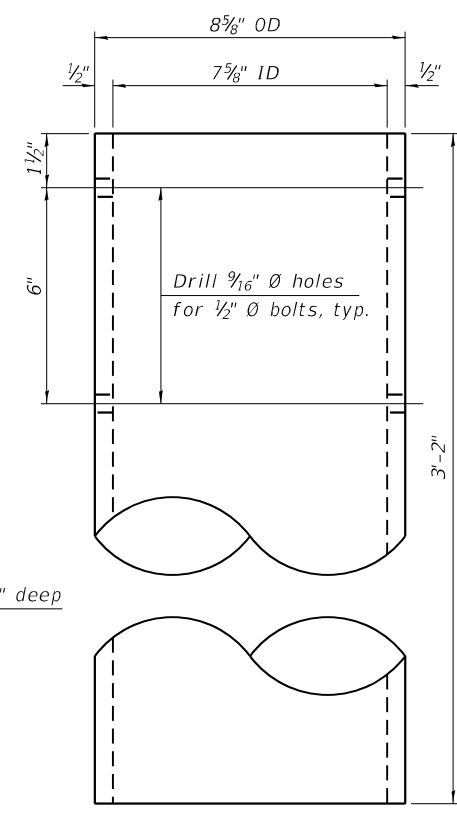
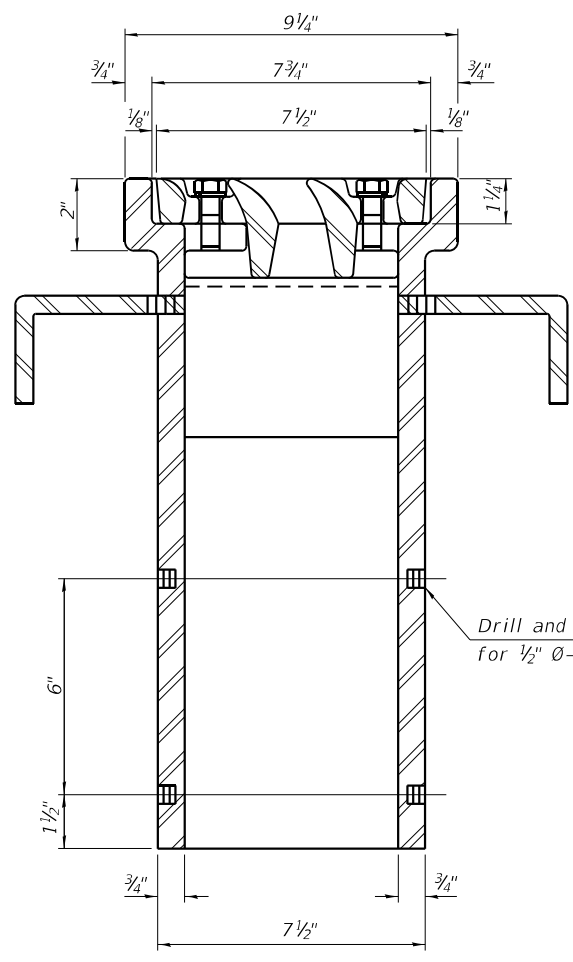
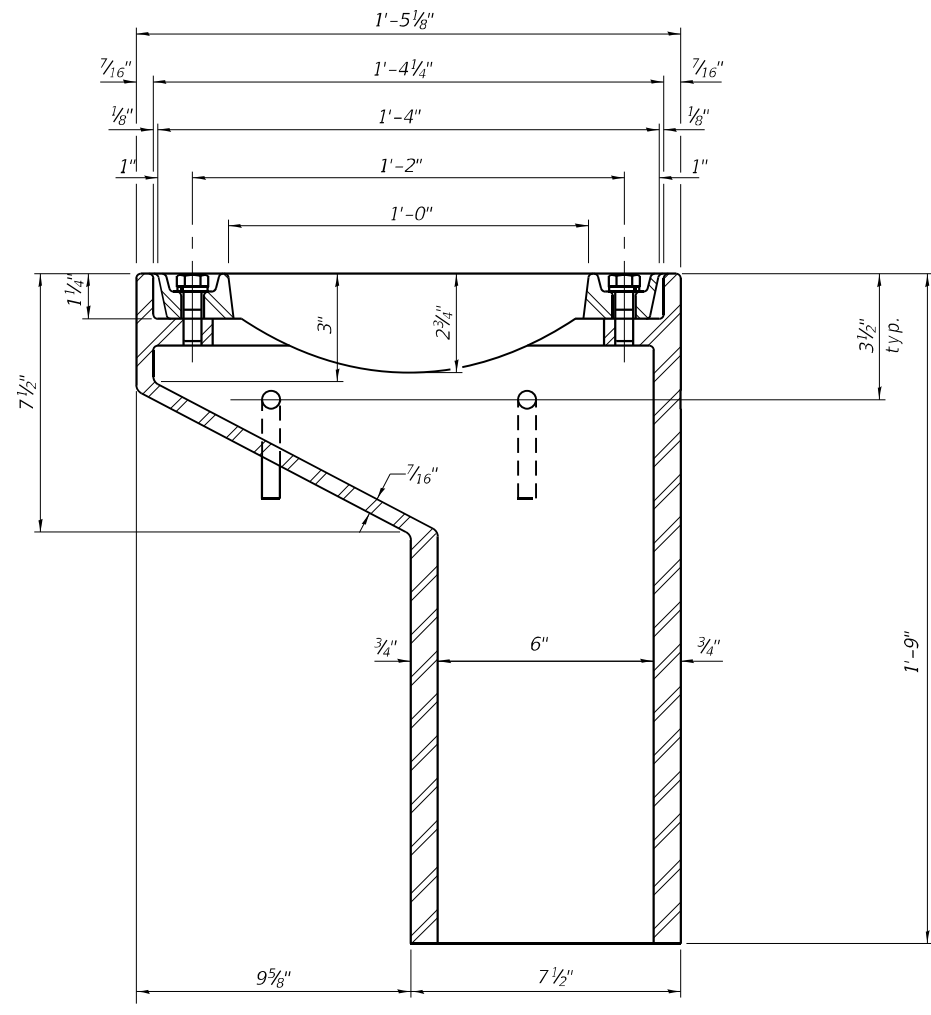

See sheet 7 of 17 for scupper location relative to parapet.

Drill and tap 4 holes 1/2" deep for 1/2" Ø-13 UNC bolts.

**BILL OF MATERIAL**

Item	Unit	Quantity
Drainage Scuppers, DS-11	Each	4

DS-11 2-1-2023



USER NAME = JCray	DESIGNED - KFO	REVISED -
0480035-68D48-010-Drainage Scuppers DS-11.dgn	CHECKED - KWB	REVISED -
PLOT SCALE = 0:2.0000 "/ in.	DRAWN - JDC	REVISED -
PLOT DATE =	CHECKED - MDC	REVISED -

STATE OF ILLINOIS  
 DEPARTMENT OF TRANSPORTATION

DRAINAGE SCUPPERS, DS-11  
 STRUCTURE NO. 048-0035

SHEET 10 OF 17 SHEETS

F.A.I. RTE.	SECTION	COUNTY	TOTAL SHEETS	SHEET NO.
74	[(72-30;48-29)HB-1]BRR	KNOX	115	97
CONTRACT NO. 68D48				
ILLINOIS		FED. AID PROJECT		

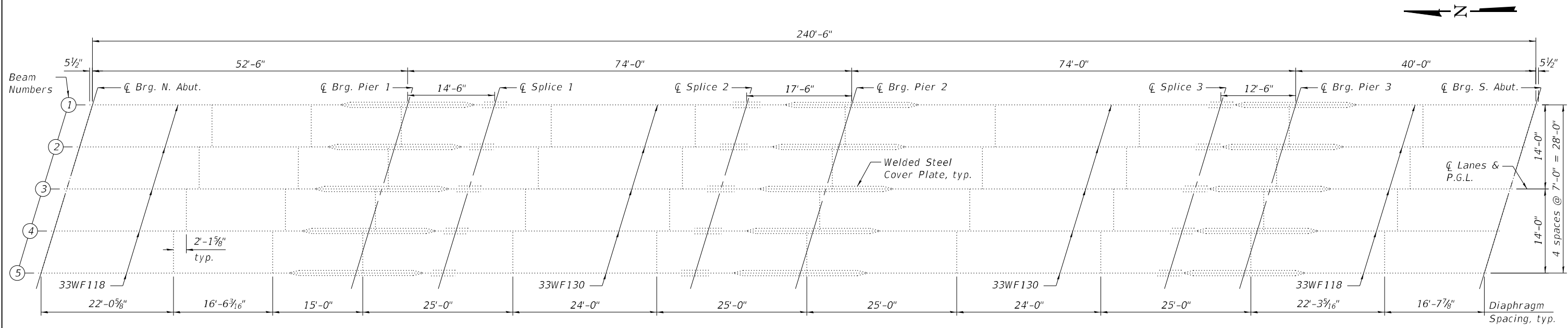

**EXISTING FRAMING PLAN**

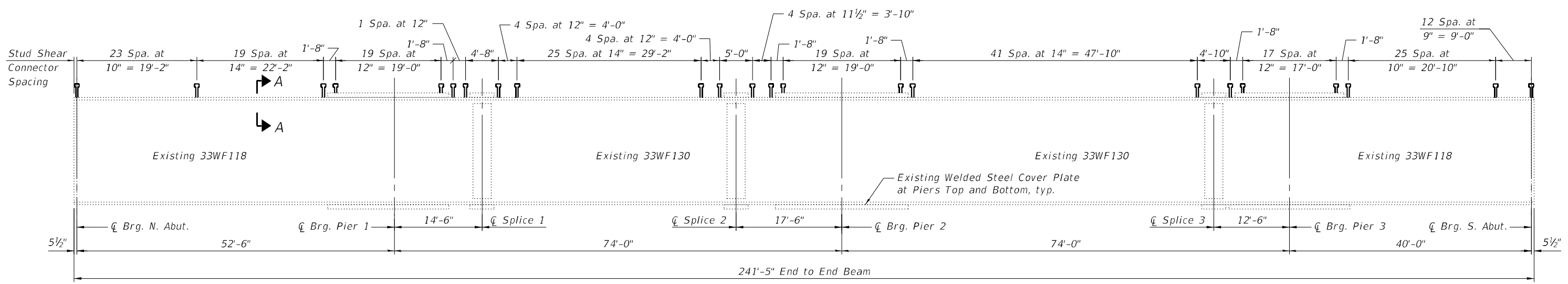

**EXISTING BEAM ELEVATION**

(Showing shear stud spacing, typ.)

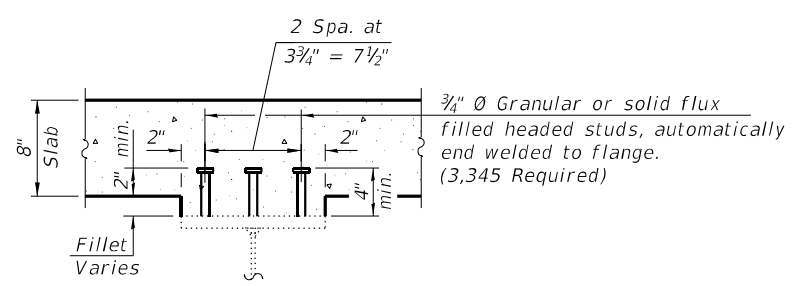

**SECTION A-A**

**BILL OF MATERIAL**

Item	Unit	Quantity
Stud Shear Connectors	Each	3,345

MODEL: Default  
 FILE NAME: S:\2022\221008 - PTB 202-26 - D4 - TMM - Various Ph I\IWO-2 & 6 CH-18 048-0035\CADD\CADD Sheets\0480035-68D48-011-Framing Plan.dgn  
 10/2/2023 1:28:43 PM

 <b>QUIGG ENGINEERING INC</b>	USER NAME = JCray 0480035-68D48-011-Framing Plan.dgn PLOT SCALE = 16:8.0000 " : / in. PLOT DATE =	DESIGNED - KFO CHECKED - KWB DRAWN - JDC CHECKED - MDC	REVISED - REVISED - REVISED - REVISED -	<b>STATE OF ILLINOIS</b> <b>DEPARTMENT OF TRANSPORTATION</b>	<b>FRAMING PLAN</b> <b>STRUCTURE NO. 048-0035</b> SHEET 11 OF 17 SHEETS	F.A.I. RTE. 74 SECTION [(72-30;48-29)HB-1]BRR COUNTY KNOX TOTAL SHEETS 115 SHEET NO. 98 CONTRACT NO. 68D48 ILLINOIS FED. AID PROJECT
----------------------------------	--	---	--	---	---	--

INTERIOR BEAM MOMENT TABLE								
		0.4 Sp. 1	Pier 1	0.5 Sp. 2	Pier 2	0.5 Sp. 3	Pier 3	0.6 Sp. 4
$I_s$	(in <sup>4</sup> )	5,900	8,453	6,710	9,674	6,710	8,453	5,900
$I_c(n)$	(in <sup>4</sup> )	20,788	25,853	22,755	28,424	22,755	25,853	20,788
$I_c(3n)$	(in <sup>4</sup> )	15,162	18,655	16,450	20,372	16,450	18,655	15,162
$S_s$	(in <sup>3</sup> )	359	501	405	567	405	501	359
$S_c(n)$	(in <sup>3</sup> )	618	788	684	876	684	788	618
$S_c(3n)$	(in <sup>3</sup> )	556	708	613	786	613	708	556
Z	(in <sup>3</sup> )	-	-	-	-	-	-	-
DL	(k/')	0.883	0.914	0.895	0.931	0.895	0.914	0.883
$M_{DL}$	(k)	145	-371	192	-475	215	-324	41
sDL	(k/')	0.353	0.353	0.353	0.353	0.353	0.353	0.353
$M_{sDL}$	(k)	59	-144	78	-185	87	-126	18
$M_{LL}$	(k)	355	-288	440	-343	430	-279	243
$M_I$	(k)	100	-76	111	-86	108	-77	73
5/3 [ $M_{LL} + M_I$ ]	(k)	758	-607	918	-715	897	-593	527
Ma	(k)	1,251	-1,459	1,544	-1,788	1,559	-1,356	762
*Mu	(k)	2,684	2,348	2,950	2,581	2,949	2,348	2,684
fs DL non-comp	(ksi)	4.9	-8.9	5.7	-10.0	6.4	-7.8	1.4
fs DL (comp)	(ksi)	1.3	-2.4	1.5	-2.8	1.7	-2.1	0.4
fs 5/3 [ $M_{LL} + M_I$ ]	(ksi)	14.7	-9.2	16.1	-9.8	15.7	-9.0	10.2
fs (Overload)	(ksi)	20.9	-20.5	23.3	-22.6	23.8	-18.9	12.0
**f <sub>s</sub> (Total)	(ksi)	-	-	-	-	-	-	-
VR	(k)	62.4	-	61.9	-	63.1	-	59.0

\* Compact section  
 \*\* Braced non-compact and partially braced section

$I_s, S_s$ : Non-composite moment of inertia and section modulus of the steel section used for computing fs(Total and Overload) due to non-composite dead loads (in.<sup>4</sup> and in.<sup>3</sup>).  
 $I_c(n), S_c(n)$ : Composite moment of inertia and section modulus of the steel and deck based upon the modular ratio, "n", used for computing fs(Total and Overload) due to short-term composite live loads (in.<sup>4</sup> and in.<sup>3</sup>).  
 $I_c(3n), S_c(3n)$ : Composite moment of inertia and section modulus of the steel and deck based upon 3 times the modular ratio, "3n", used for computing fs(Total and Overload) due to long-term composite (superimposed) dead loads (in.<sup>4</sup> and in.<sup>3</sup>).  
 Z: Plastic Section Modulus of the steel section in non-composite areas (in.<sup>3</sup>).  
 $q$ : Un-factored non-composite dead load (kips/ft.).  
 $M_{DL}$ : Un-factored moment due to non-composite dead load (kip-ft.).  
 $s_{DL}$ : Un-factored long-term composite (superimposed) dead load (kips/ft.).  
 $M_{sDL}$ : Un-factored moment due to long-term composite (superimposed) dead load (kip-ft.).  
 $M_{LL}$ : Un-factored live load moment (kip-ft.).  
 $M_I$ : Un-factored moment due to impact (kip-ft.).  
 Ma: Factored design moment (kip-ft.).  
 $1.3 [M_{DL} + M_{sDL} + \frac{5}{3} (M_{LL} + M_I)]$   
 Mu: Compact composite moment capacity according to AASHTO LFD 10.50.1.1 or compact non-composite moment capacity according to AASHTO LFD 10.48.1 (kip-ft.).  
 fs (Overload): Sum of stresses as computed from the moments below (ksi).  
 $M_{DL} + M_{sDL} + \frac{5}{3} (M_{LL} + M_I)$   
 fs (Total): Sum of stresses as computed from the moments below on non-compact section (ksi).  
 $1.3 [M_{DL} + M_{sDL} + \frac{5}{3} (M_{LL} + M_I)]$   
 VR: Maximum  $t$  + impact shear range within the composite portion of the span for stud shear connector design (kips).

INTERIOR GIRDER REACTION TABLE						
		N. Abut.	Pier 1	Pier 2	Pier 3	S. Abut.
$R_{DL}$	(k)	23.6	87.1	98.0	79.8	14.4
$R_{LL}$	(k)	41.0	48.6	50.0	49.4	38.5
$R_I$	(k)	11.6	13.0	12.5	13.5	11.5
$R_{Total}$	(k)	76.2	148.7	160.5	142.7	64.4

MODEL: Default  
 FILE NAME: S:\2022\2121008 - PTB 202-26 - D4 - TMM - Various Ph I-II\WC-2 & 6 CH-18 048-0035\CADD\CADD Sheets\0480035-68D48-012-Design Data Tables.dgn  
 10/2/2023 1:28:52 PM



USER NAME = JCray	DESIGNED - KFO	REVISED -
0480035-68D48-012-Design Data Tables.dgn	CHECKED - KWB	REVISED -
PLOT SCALE = 16:8.0000 '":' / in.	DRAWN - JDC	REVISED -
PLOT DATE =	CHECKED - MDC	REVISED -

STATE OF ILLINOIS  
 DEPARTMENT OF TRANSPORTATION

DESIGN DATA TABLES  
 STRUCTURE NO. 048-0035

SHEET 12 OF 17 SHEETS

F.A.I. RTE.	SECTION	COUNTY	TOTAL SHEETS	SHEET NO.
74	[(72-30;48-29)HB-1]BRR	KNOX	115	99
CONTRACT NO. 68D48				
ILLINOIS		FED. AID PROJECT		

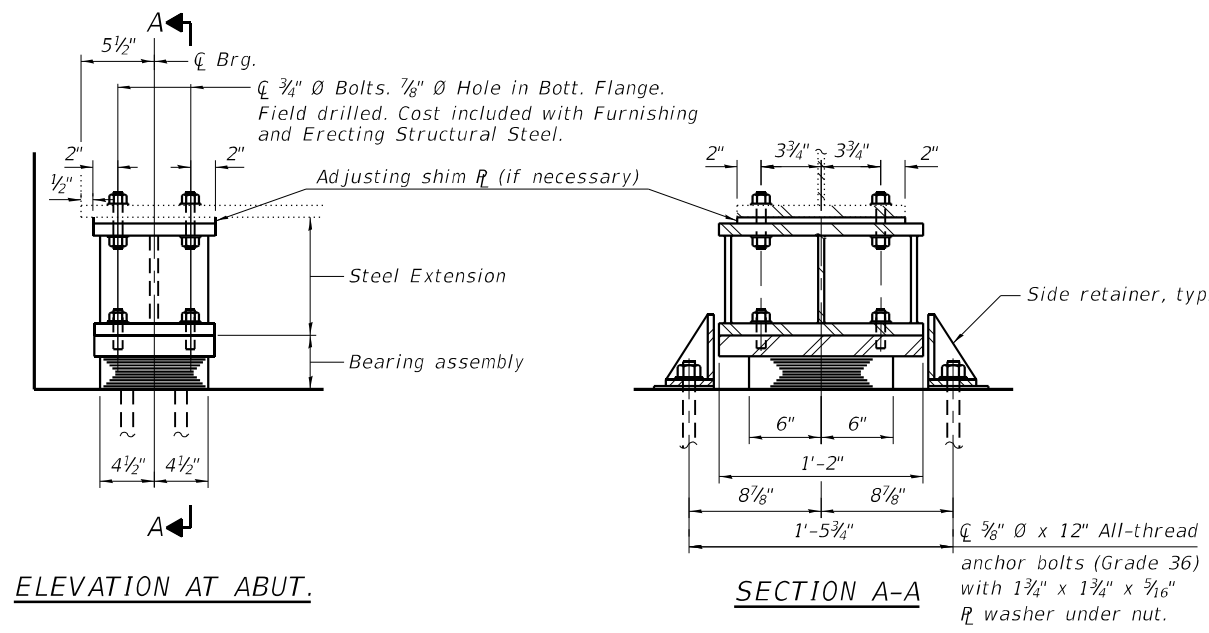

ELEVATION AT ABUT.

SECTION A-A

5/8" Ø x 12" All-thread anchor bolts (Grade 36) with 1 3/4" x 1 3/4" x 5/16" R washer under nut.

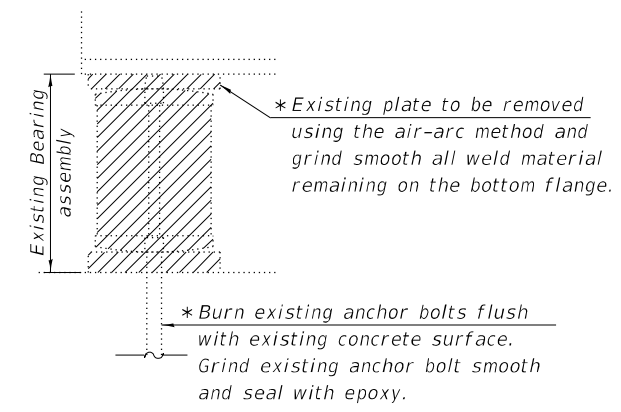

EXISTING BEARING REMOVAL DETAIL

\* Cost included with Jack and Remove Existing Bearings.

**TYPE I ELASTOMERIC EXP. BRG.**  
(10 Required)

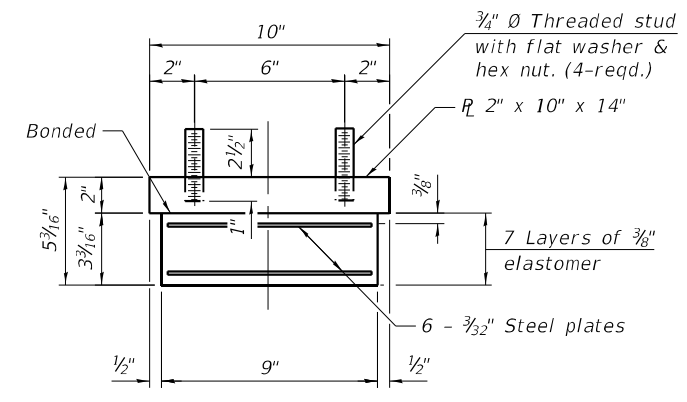

BEARING ASSEMBLY

**Notes:**  
Side retainers and stainless steel plates shall be included in the cost of Elastomeric Bearing Assembly, Type I.  
Anchor bolts and side retainers at all supports shall be installed as each existing bearing assembly is replaced unless an equivalent temporary means of lateral restraint is used.  
Two 1/8 in. adjusting shims shall be provided for each bearing in addition to all other plates or shims and placed as shown on bearing details.  
Prior to ordering extensions & shims, the Contractor shall field-verify the height between the bottom of beam and its seat at each bearing as this height shall be maintained.  
All steel extensions, bearing plates, side retainers, anchor bolts, nuts, washers and pintles shall be galvanized according to AASHTO M111 or M232 as applicable.

Note:  
Shim plates shall not be placed under bearing assembly.

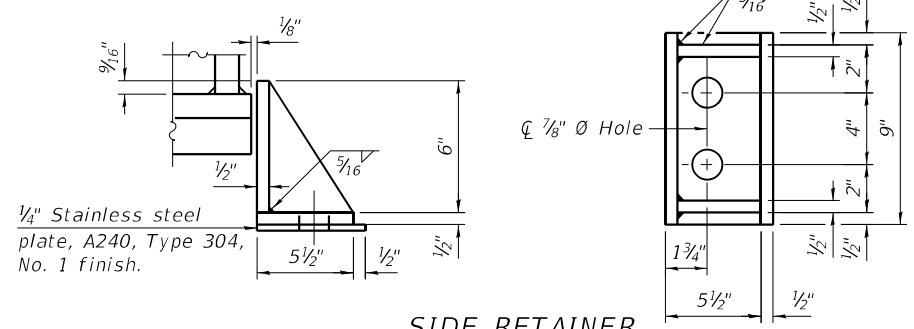

SIDE RETAINER

Equivalent rolled angle with stiffeners will be allowed in lieu of welded plates.

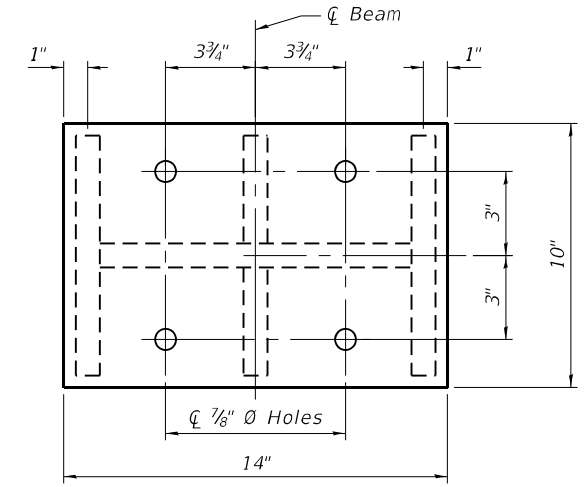

PLAN STEEL EXTENSION

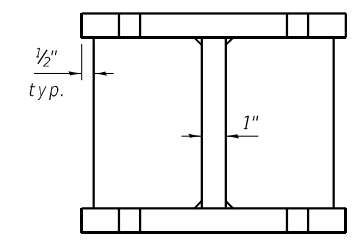

SECTION B-B

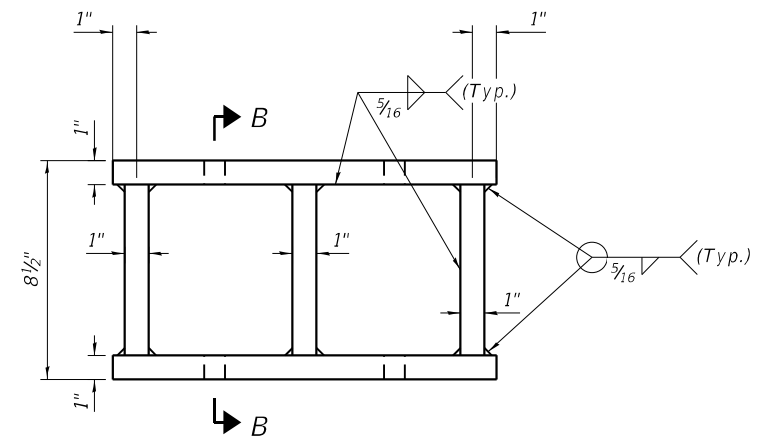

ELEVATION STEEL EXTENSION

**BILL OF MATERIAL**

Item	Unit	Total
Elastomeric Bearing Assembly Type I	Each	10
Anchor Bolts, 5/8"	Each	40
Jack and Remove Existing Bearings	Each	10
F. & E. Structural Steel	Pound	1,540

STATE OF ILLINOIS  
DEPARTMENT OF TRANSPORTATION

BEARING DETAILS  
STRUCTURE NO. 048-0035

SHEET 13 OF 17 SHEETS

F.A.I. RTE.	SECTION	COUNTY	TOTAL SHEETS	SHEET NO.
74	[(72-30;48-29)HB-1]BR	KNOX	115	100
CONTRACT NO. 68D48				
ILLINOIS FED. AID PROJECT				

MODEL: Default  
FILE NAME: S:\2022\212L008 - PTB 202-26 - D4 - TMM - Various Ph I-11WOC-2 & 6 CH-18 048-0035\CADD\CADD Sheets\0480035-68D48-013-Bearing Details.dgn  
10/2/2023 1:29:00 PM



USER NAME = JCray	DESIGNED - KFO	REVISED -
0480035-68D48-013-Bearing Details.dgn	CHECKED - KWB	REVISED -
PLOT SCALE = 0:2.0000 "/in.	DRAWN - JDC	REVISED -
PLOT DATE =	CHECKED - MDC	REVISED -

MODEL: Default  
 FILE NAME: S:\2022\212L008 - PTB 202-26 - D4 - TMM - Various Ph I-II\WC-2 & 6 CH-18 048-0035\CADD\CADD Sheets\0480035-68D48-014-N. Abutment Removal.dgn  
 10/2/2023 1:29:11 PM

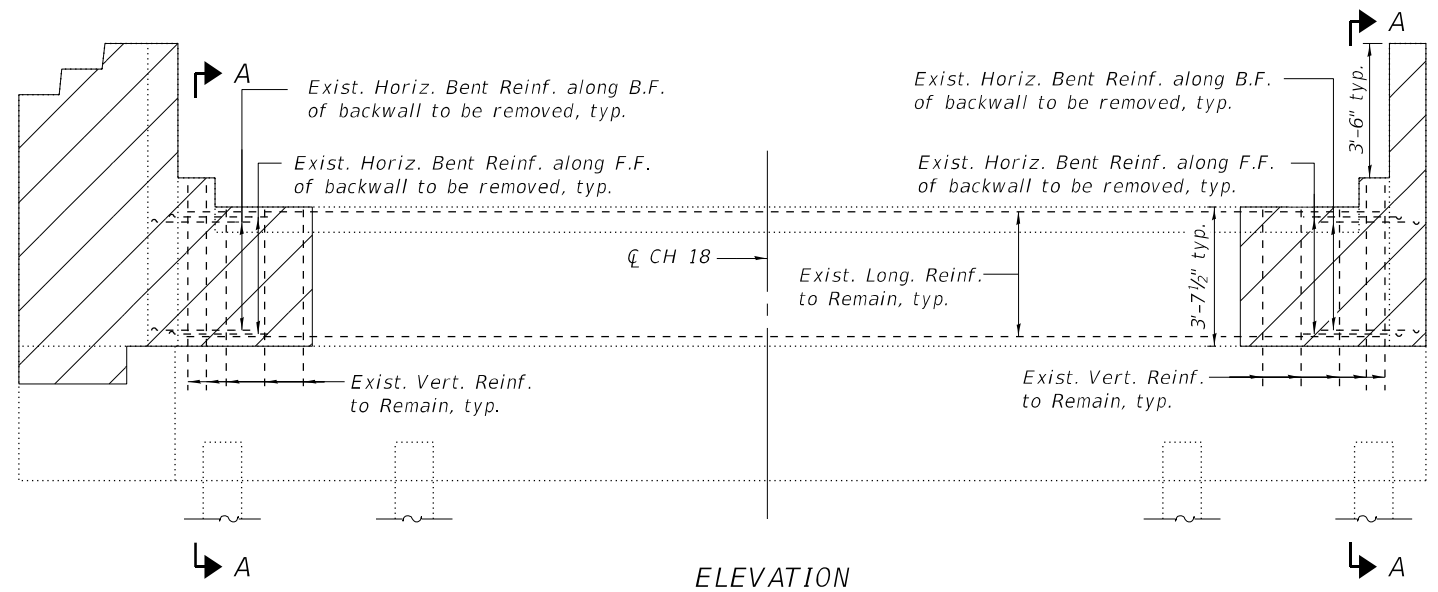

**ELEVATION**

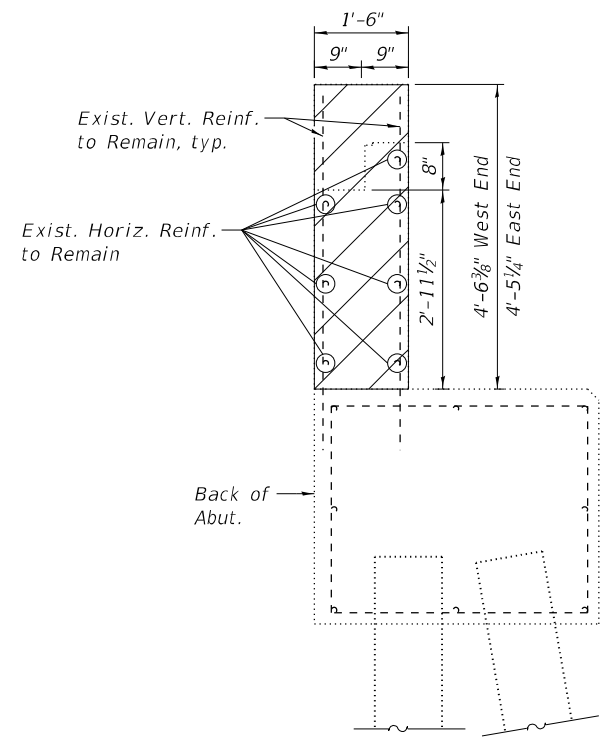

**SECTION A-A**  
(At Rt. L's)

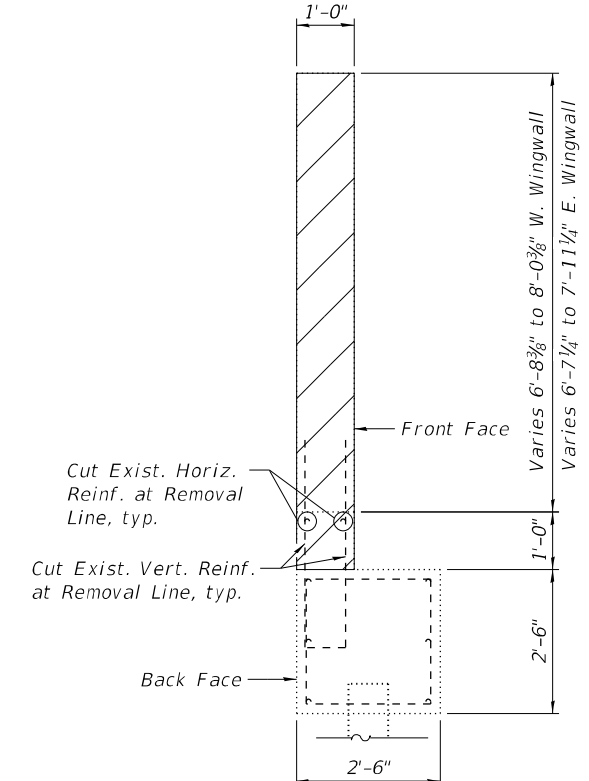

**SECTION B-B**

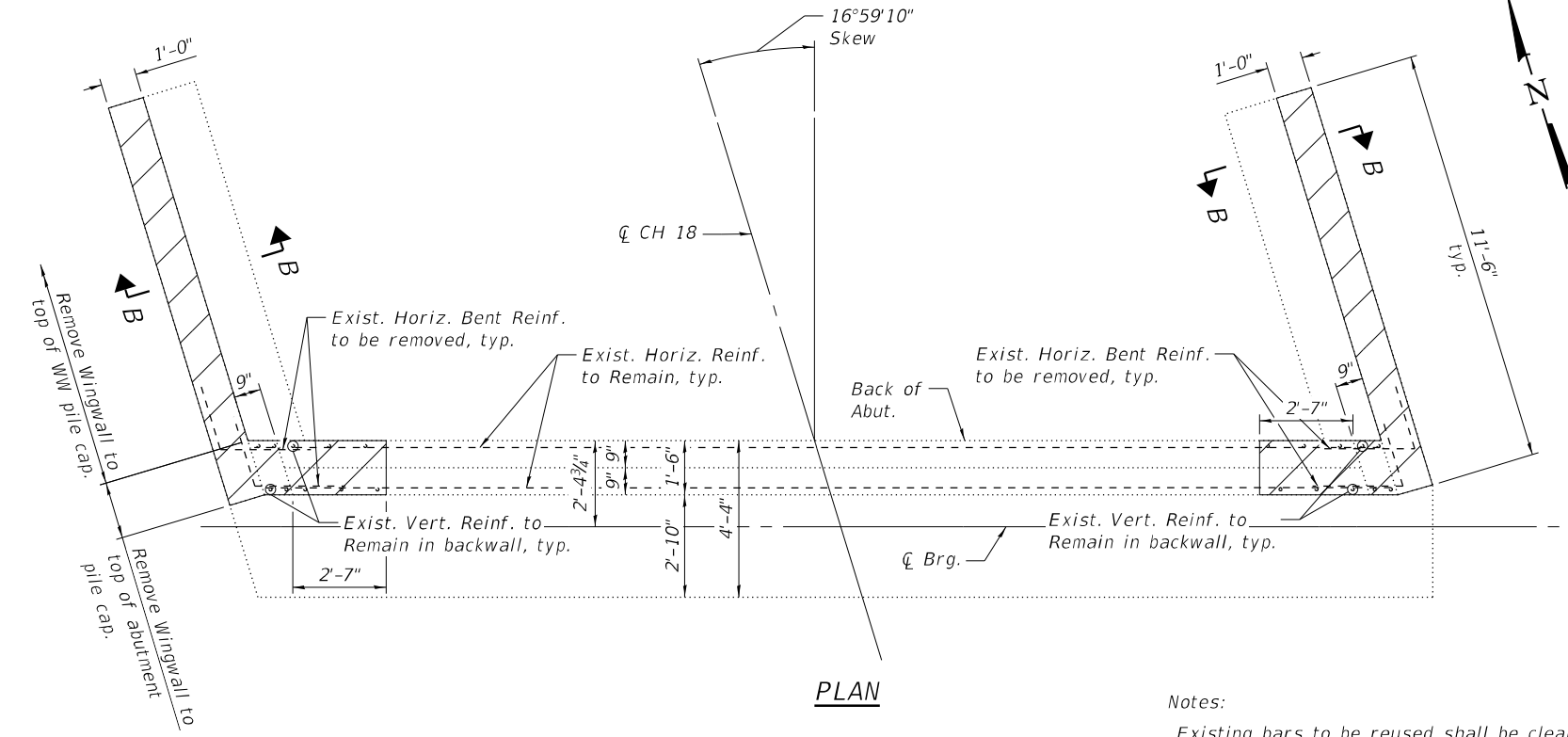

**PLAN**

**BILL OF MATERIAL**

Item	Unit	Quantity
Concrete Removal	Cu. Yd.	8.5



Notes:  
 Existing bars to be reused shall be cleaned, straightened, and incorporated into the new construction. Cost included with Concrete Removal.

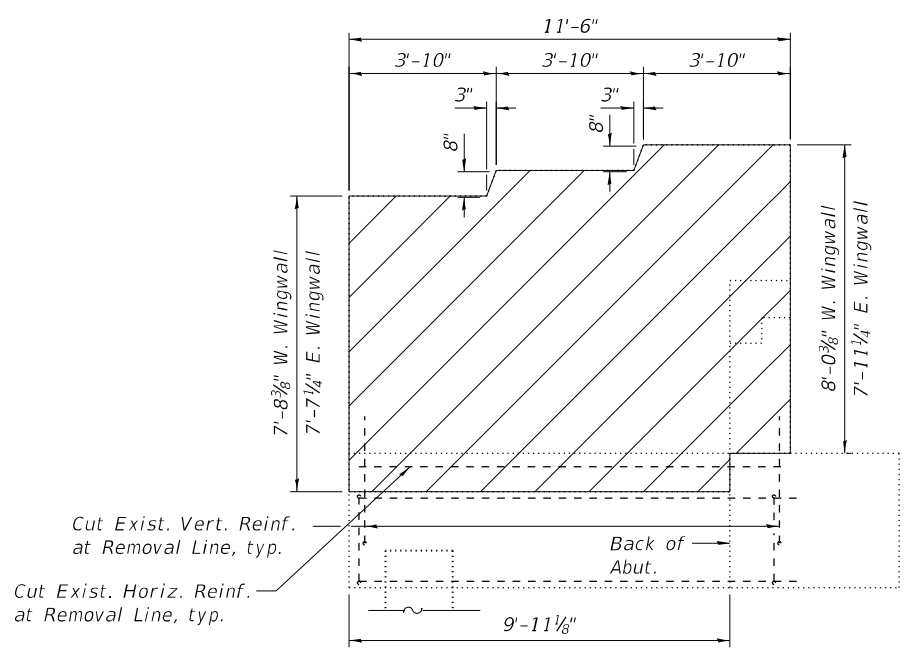

**WINGWALL ELEVATION**



USER NAME = J.Cray	DESIGNED - KFO	REVISED -
0480035-68D48-014-N. Abutment Removal.dgn	CHECKED - KWB	REVISED -
PLOT SCALE = 5:0.0000 "/ in.	DRAWN - JDC	REVISED -
PLOT DATE =	CHECKED - MDC	REVISED -

**STATE OF ILLINOIS**  
**DEPARTMENT OF TRANSPORTATION**

**NORTH ABUTMENT REMOVAL DETAILS**  
**STRUCTURE NO. 048-0035**

SHEET 14 OF 17 SHEETS

F.A.I. RTE. 74	SECTION [(72-30;48-29)HB-1]BRR	COUNTY KNOX	TOTAL SHEETS 115	SHEET NO. 101
CONTRACT NO. 68D48				
ILLINOIS FED. AID PROJECT				

MODEL: Default  
 FILE NAME: S:\2022\212L008 - PTB 202-26 - D4 - TMM - Various Ph I-IIWO-2 & 6 CH-18 048-0035\CADD\CADD Sheets\0480035-68D48-015-S - Abutment Removal.dgn  
 10/2/2023 1:29:19 PM

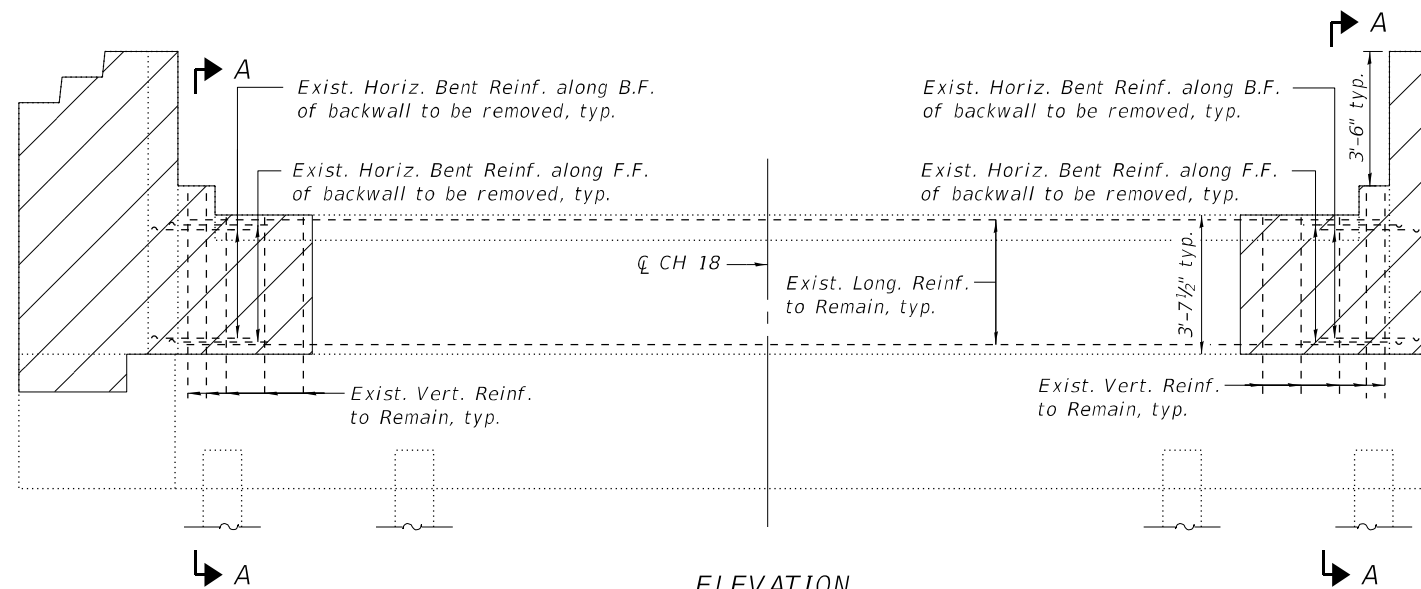

**ELEVATION**

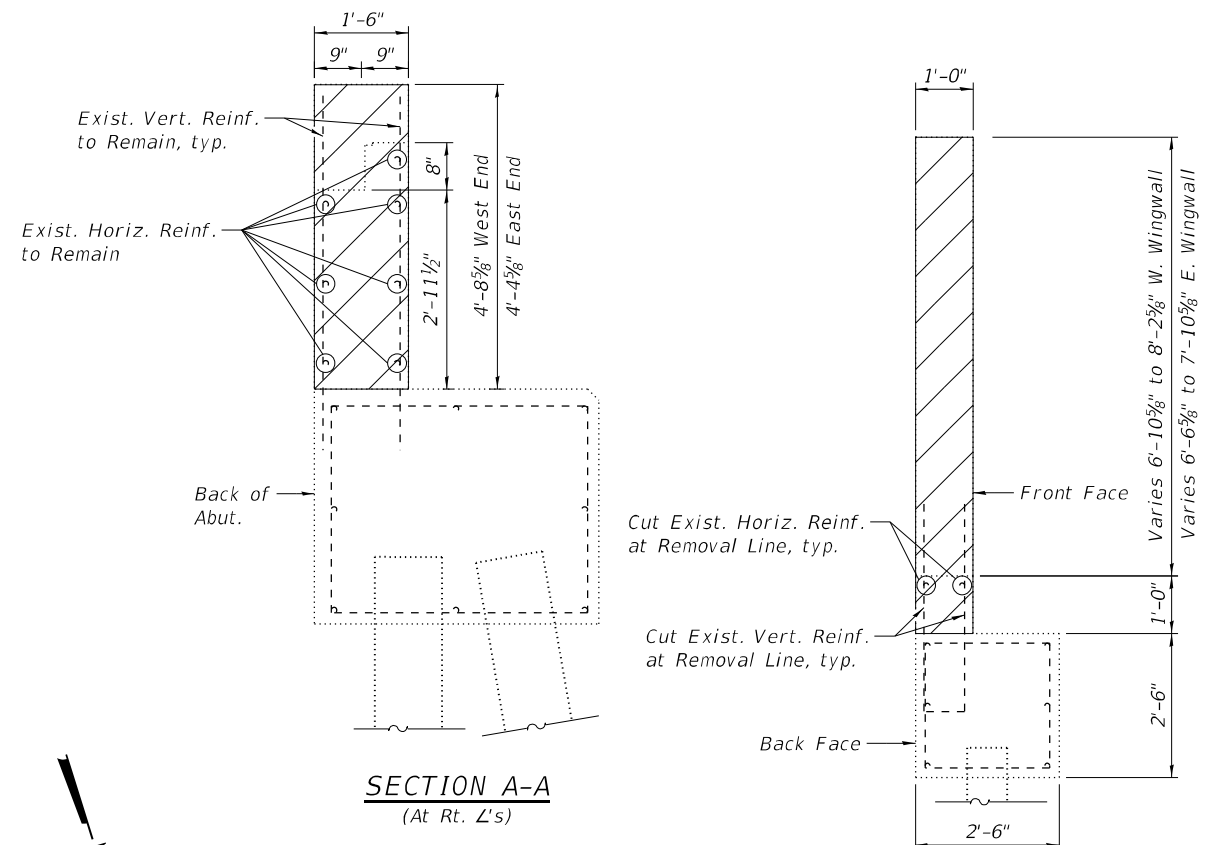

**SECTION A-A**  
(At Rt. L's)

**SECTION B-B**

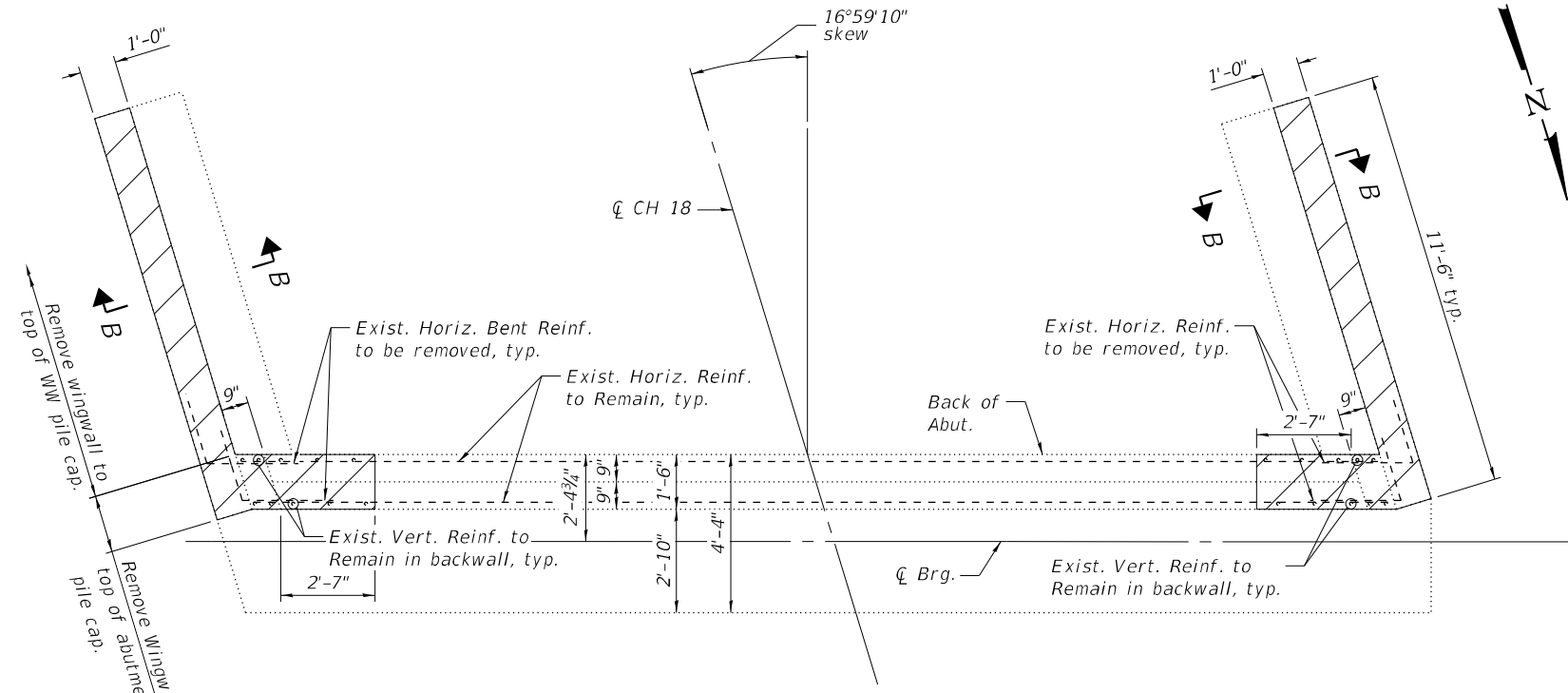

**PLAN**

**BILL OF MATERIAL**

Item	Unit	Quantity
Concrete Removal	Cu. Yd.	8.6

**LEGEND**



Notes:  
 Existing bars to be reused shall be cleaned, straightened, and incorporated into the new construction. Cost included with Concrete Removal.

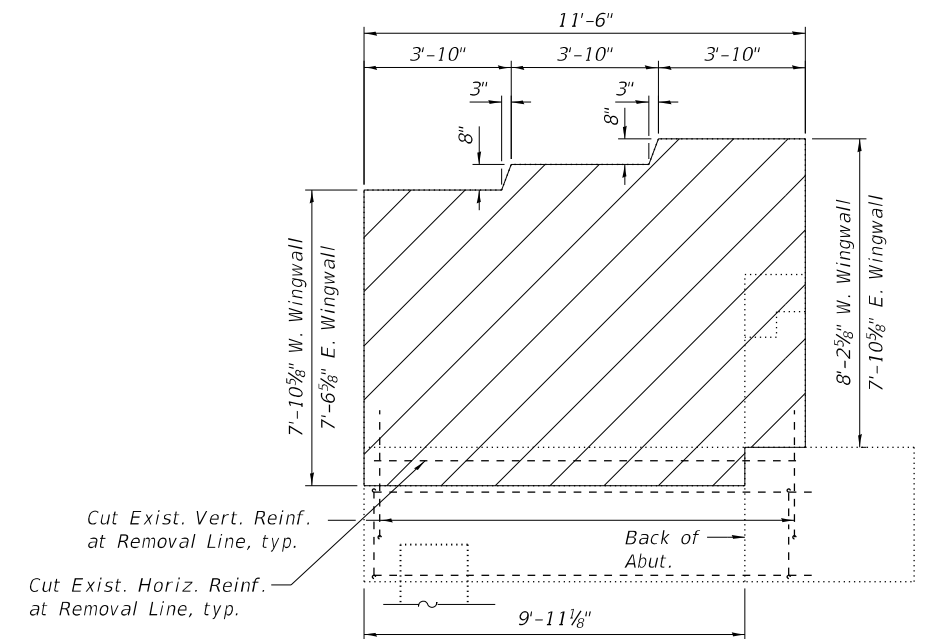

**WINGWALL ELEVATION**



USER NAME = J.Cray	DESIGNED - KFO	REVISED -
0480035-68D48-015-S, Abutment Removal.dgn	CHECKED - KWB	REVISED -
PLOT SCALE = 5:0.0028 "/> <td>DRAWN - JDC</td> <td>REVISED -</td>	DRAWN - JDC	REVISED -
PLOT DATE =	CHECKED - MDC	REVISED -

**STATE OF ILLINOIS**  
**DEPARTMENT OF TRANSPORTATION**

**SOUTH ABUTMENT REMOVAL DETAILS**  
**STRUCTURE NO. 048-0035**

SHEET 15 OF 17 SHEETS

F.A.I. RTE.	SECTION	COUNTY	TOTAL SHEETS	SHEET NO.
74	[(72-30;48-29)HB-1]BR	KNOX	115	102
CONTRACT NO. 68D48				
ILLINOIS		FED. AID PROJECT		

MODEL: Default  
 FILE NAME: S:\2022\212L008 - PTB 202-26 - D4 - TMM - Various Ph I-II\WC-2 & 6 CH-18 048-0035\CADD\CADD Sheets\0480035-68D48-016-N. Abut. Modifications.dgn  
 10/2/2023 1:29:29 PM

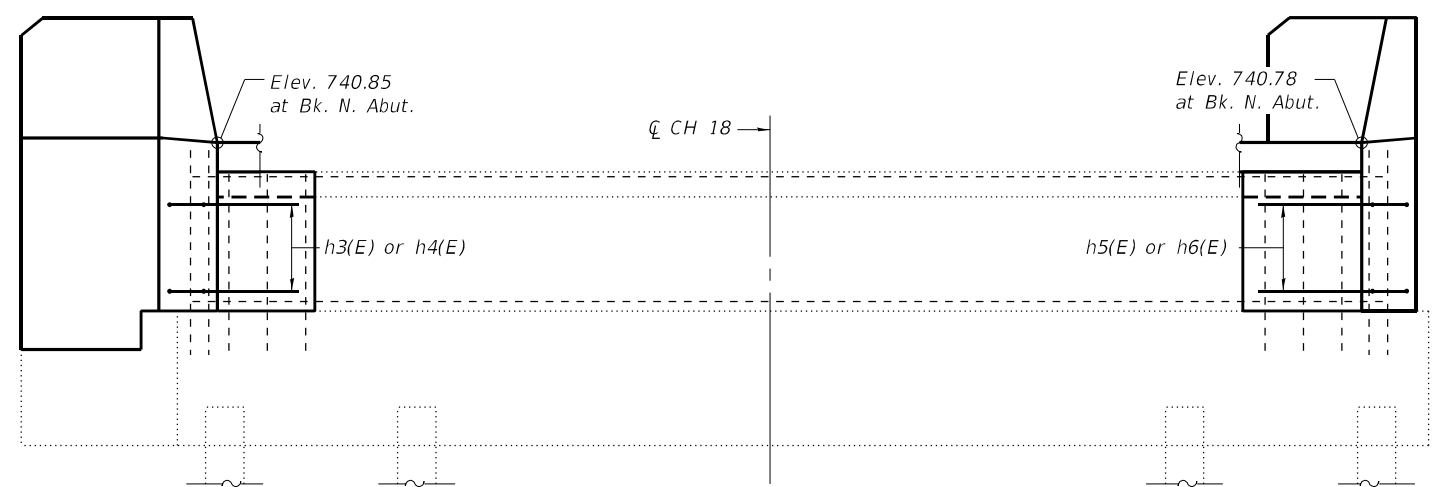

**ELEVATION**

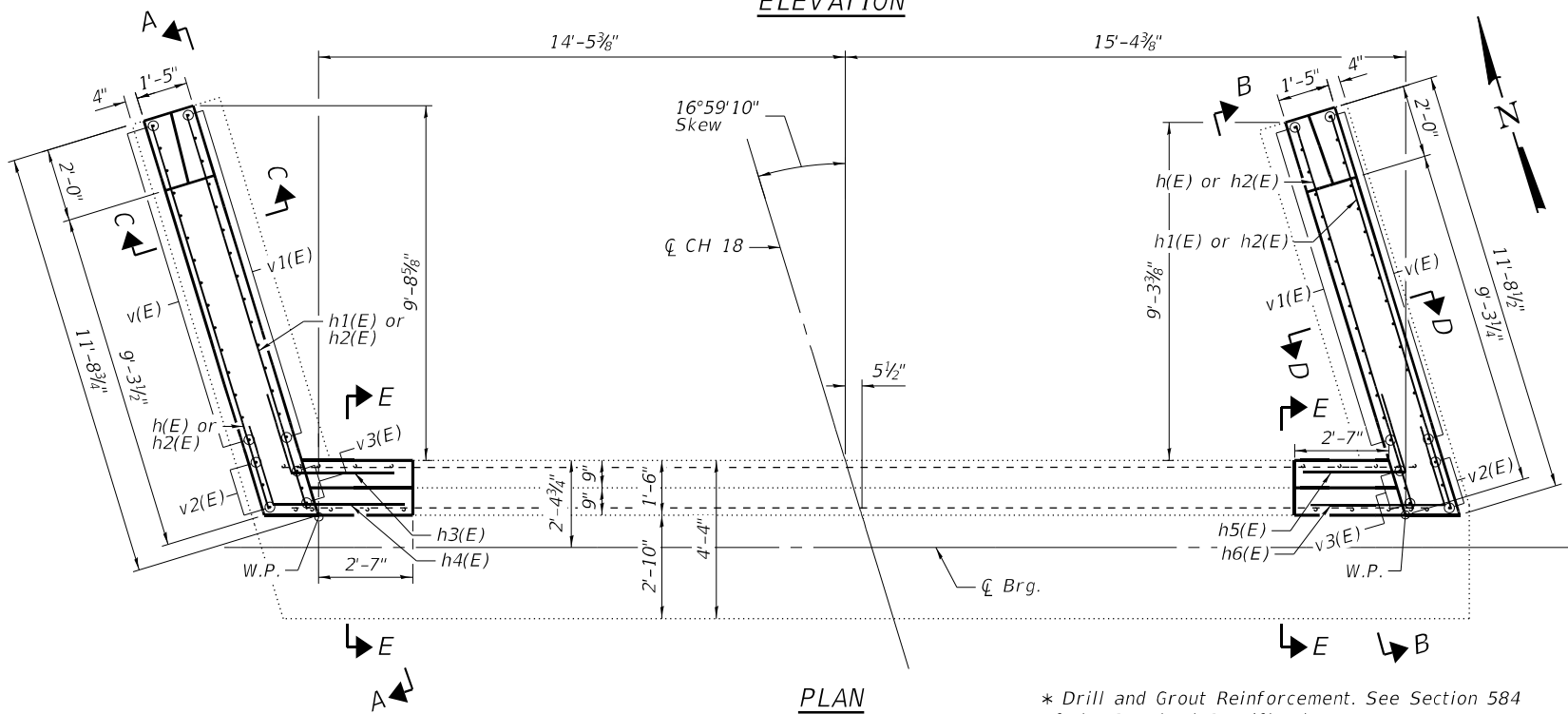

**PLAN**

- (1) 3-#5 v2(E) bars at ±8" cts., O.F.
- (2) 3-#6 v3(E) bars at ±8" cts., I.F.
- (3) 2-#4 h2(E) bars each face

Notes:  
 Drilling and grouting bars included in cost of Reinforcement Bars, Epoxy Coated

\* Drill and Grout Reinforcement. See Section 584 of the Standard Specifications.

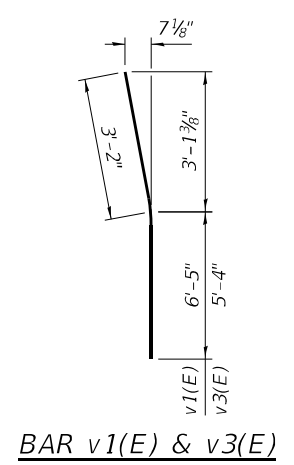

**BAR v1(E) & v3(E)**

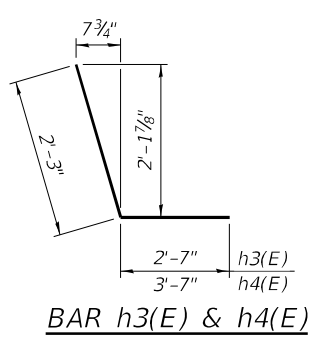

**BAR h3(E) & h4(E)**

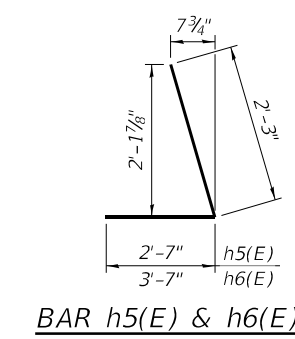

**BAR h5(E) & h6(E)**

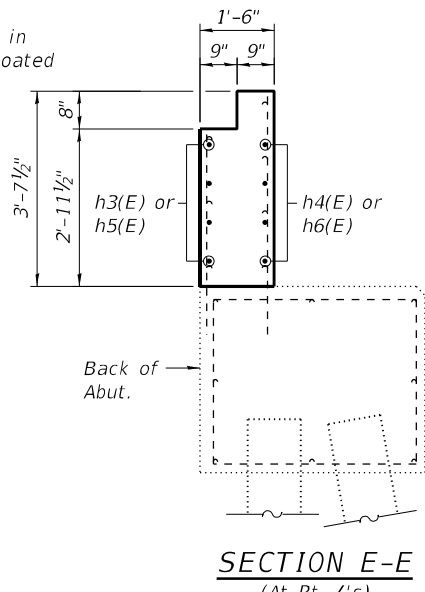

**SECTION E-E**  
(At Rt. L's)

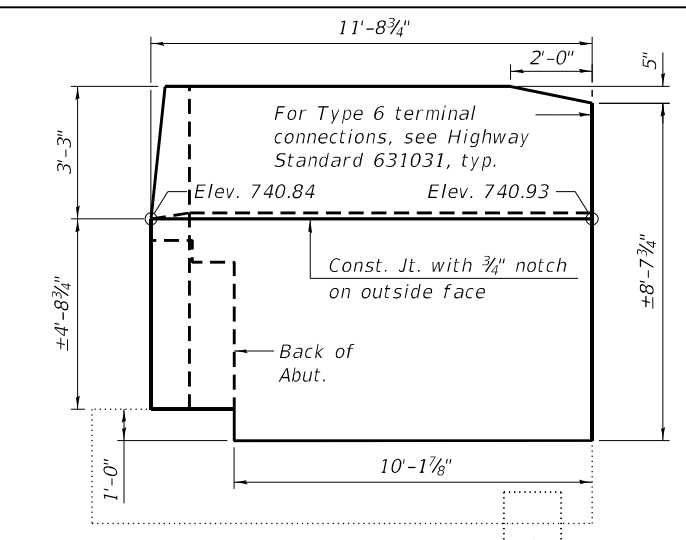

**SECTION A-A**  
(Showing dimensions)

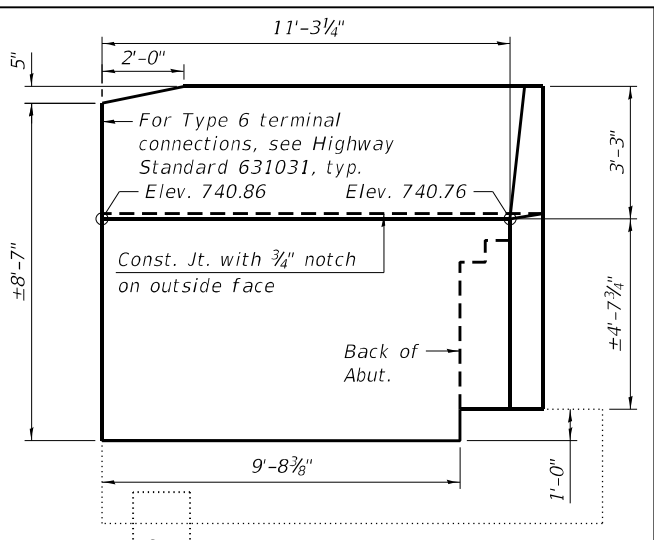

**SECTION B-B**  
(Showing dimensions)

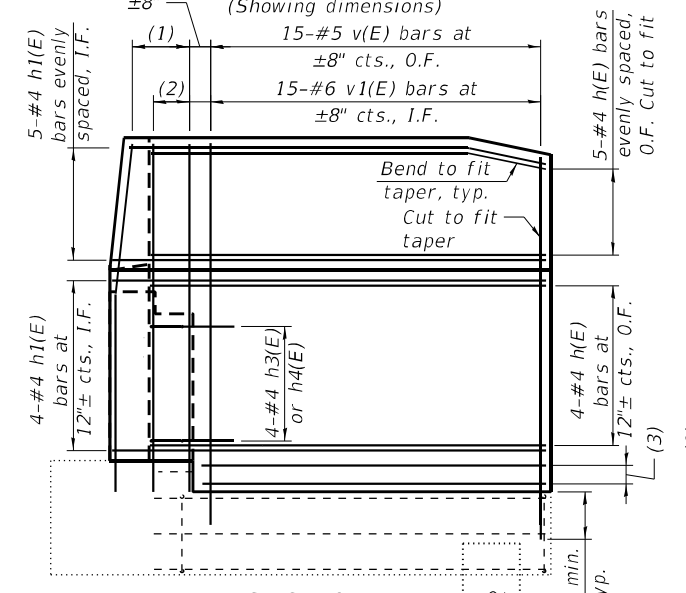

**SECTION A-A**  
(Showing reinforcement)

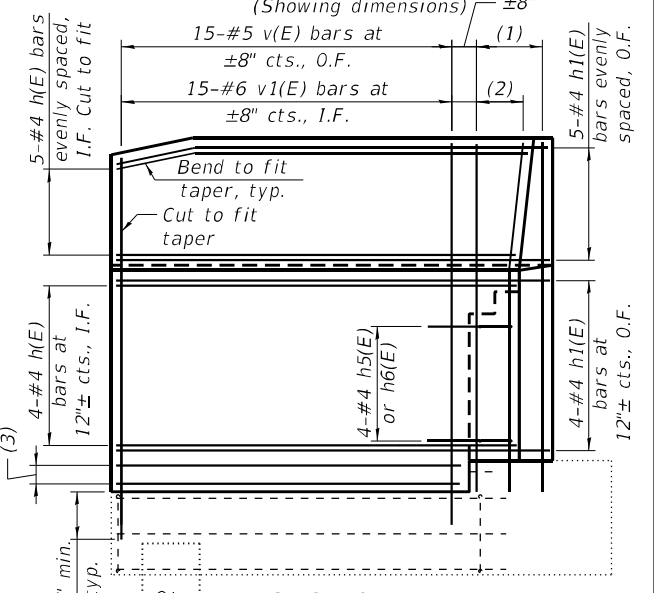

**SECTION B-B**  
(Showing reinforcement)

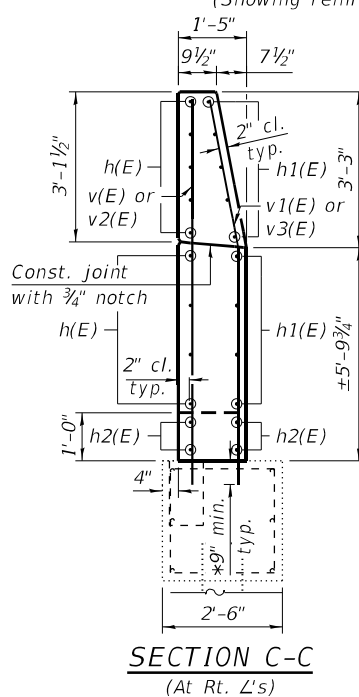

**SECTION C-C**  
(At Rt. L's)

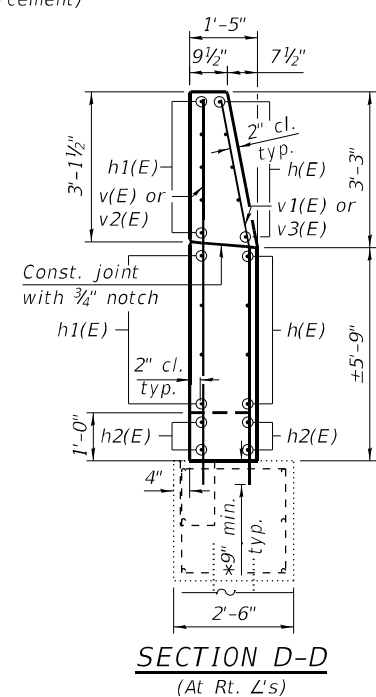

**SECTION D-D**  
(At Rt. L's)

**BILL OF MATERIAL**

Bar	No.	Size	Length	Shape
h(E)	18	#4	10'-11"	—
h1(E)	18	#4	11'-4"	—
h2(E)	8	#4	9'-4"	—
h3(E)	4	#4	4'-10"	↘
h4(E)	4	#4	5'-10"	↘
h5(E)	4	#4	4'-10"	↘
h6(E)	4	#4	5'-10"	↘
v(E)	30	#5	9'-7"	—
v1(E)	30	#6	9'-7"	—
v2(E)	6	#5	8'-5"	—
v3(E)	6	#6	8'-6"	—
Structure Excavation		Cu. Yd.	54	
Concrete Structures		Cu. Yd.	7.9	
Reinforcement Bars, Epoxy Coated		Pound	1,240	



USER NAME = J.Cray	DESIGNED - KFO	REVISED -
0480035-68D48-016-N. Abut. Modifications.dgn	CHECKED - KWB	REVISED -
PLOT SCALE = 50.0000 "/ in.	DRAWN - JDC	REVISED -
PLOT DATE =	CHECKED - MDC	REVISED -

**STATE OF ILLINOIS**  
**DEPARTMENT OF TRANSPORTATION**

**NORTH ABUTMENT MODIFICATION DETAILS**  
**STRUCTURE NO. 048-0035**

SHEET 16 OF 17 SHEETS

F.A.I. RTE.	SECTION	COUNTY	TOTAL SHEETS	SHEET NO.
74	[(72-30;48-29)HB-1]BR	KNOX	115	103
CONTRACT NO. 68D48				
		ILLINOIS	FED. AID PROJECT	



MODEL: Default  
 FILE NAME: S:\2022\221008 - PTB 202-26 - D4 - TMM - Various Ph I-IIWOC-2 & 6 CH-18 048-0035\CADD\CADD Sheets\0480035-68D48-017-S, Abut. Modifications.dgn  
 10/2/2023 1:29:38 PM

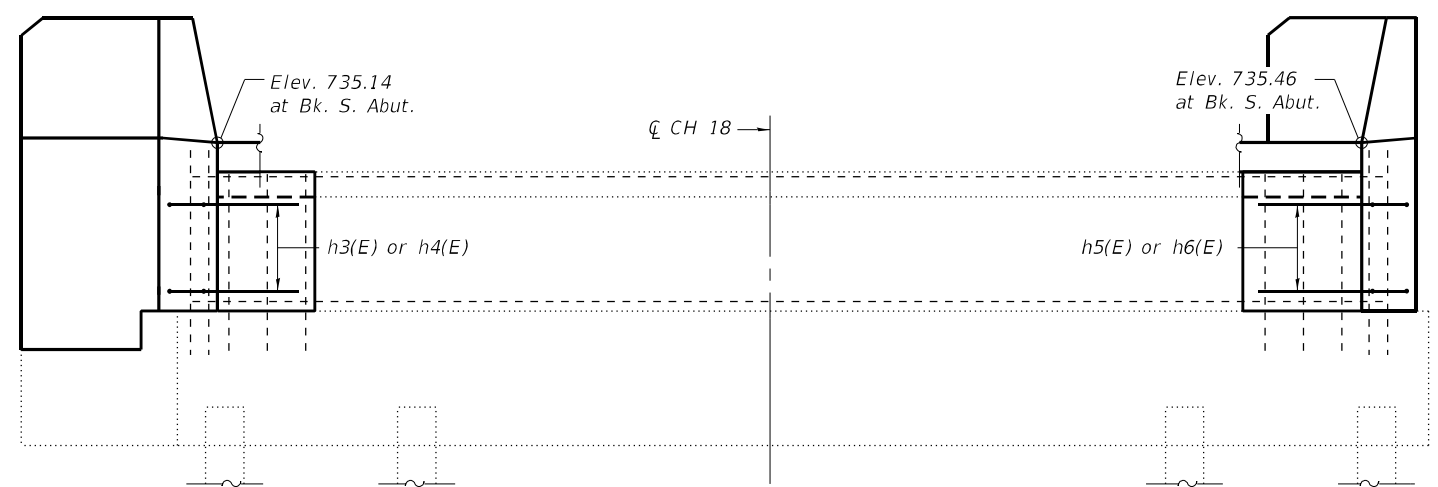

ELEVATION

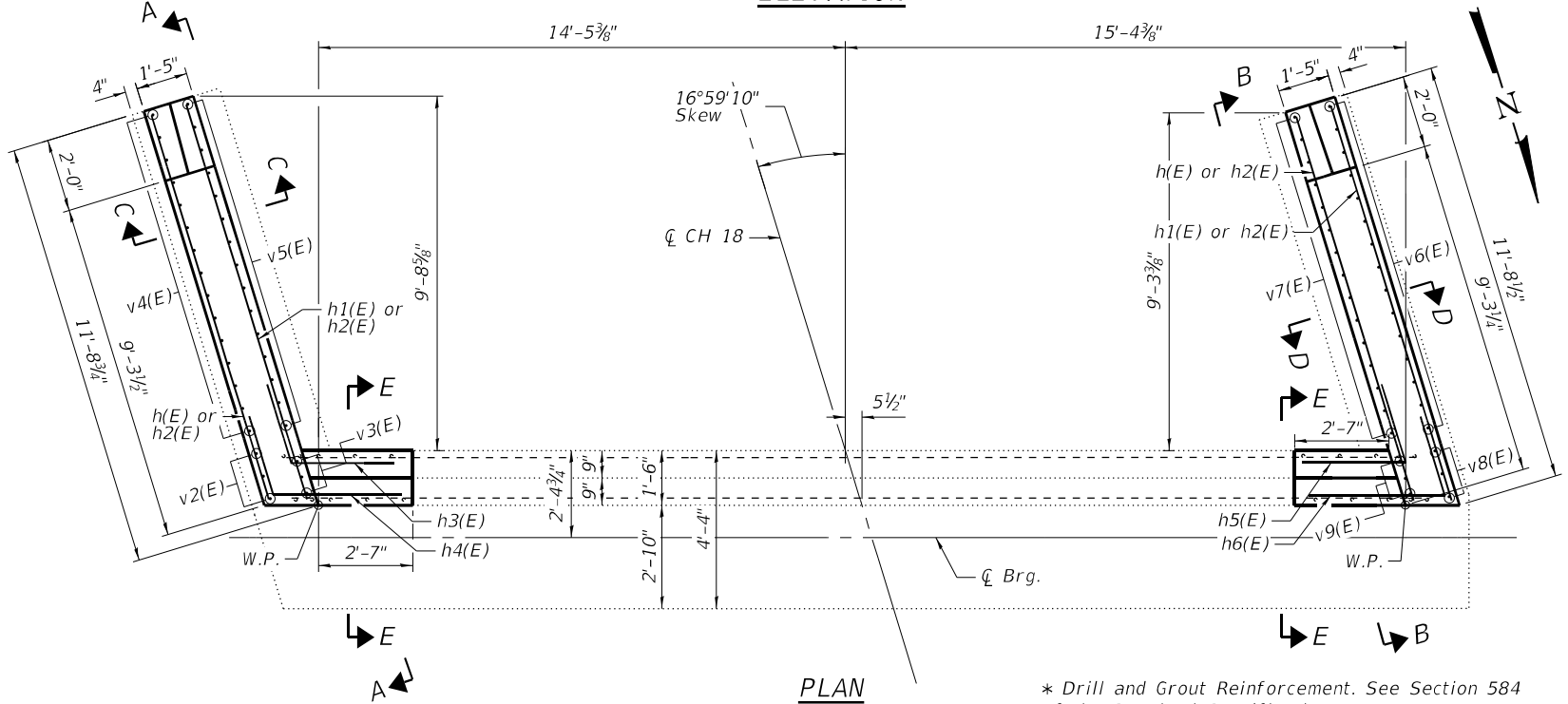

PLAN

- (1) 3-#5 v2(E) bars at ±8" cts., O.F.
- (2) 3-#6 v3(E) bars at ±8" cts., I.F.
- (3) 2-#4 h2(E) bars each face
- (4) 3-#5 v8(E) bars at ±8" cts., O.F.
- (5) 3-#6 v9(E) bars at ±8" cts., I.F.

Notes:  
 Drilling and grouting bars included in cost of Reinforcement Bars, Epoxy Coated.

\* Drill and Grout Reinforcement. See Section 584 of the Standard Specifications.

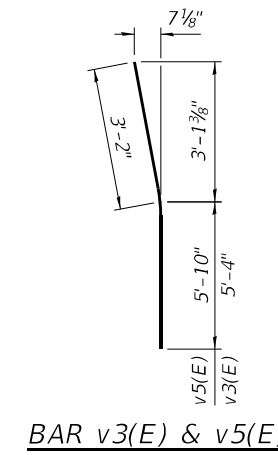

BAR v3(E) & v5(E)

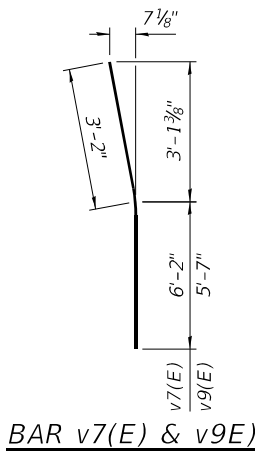

BAR v7(E) & v9(E)

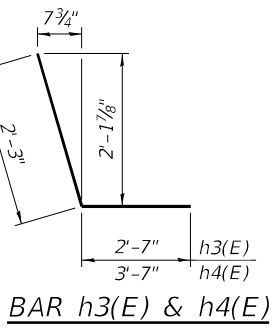

BAR h3(E) & h4(E)

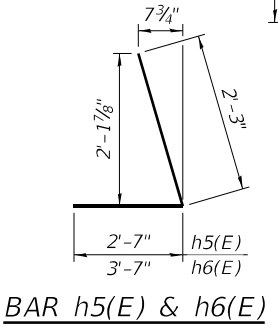

BAR h5(E) & h6(E)

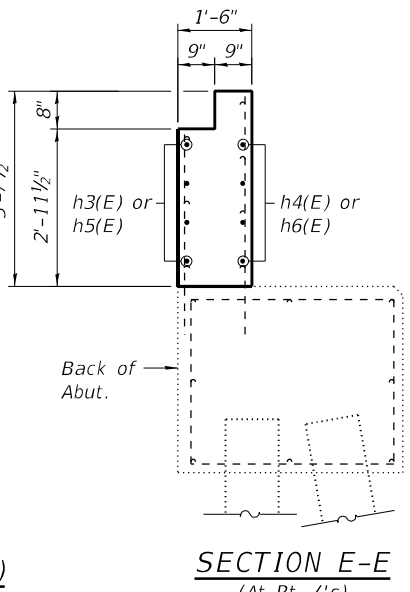

SECTION E-E  
 (At Rt. L's)

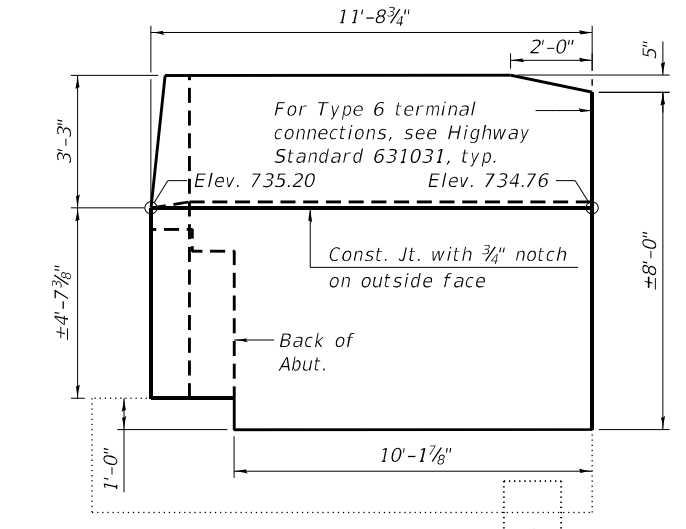

SECTION A-A  
 (Showing dimensions)

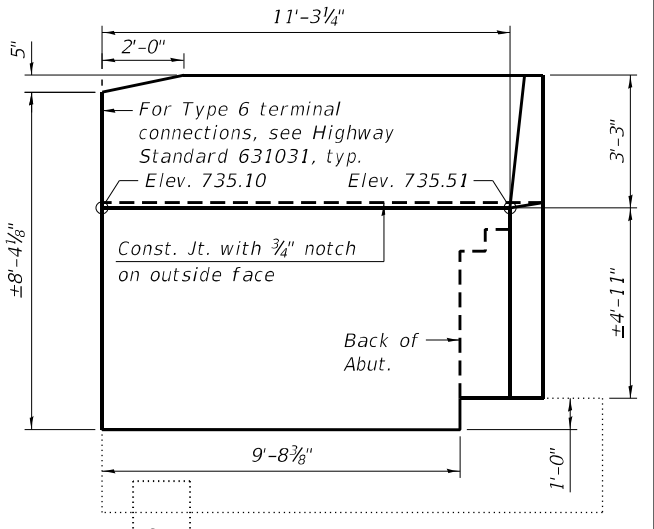

SECTION B-B  
 (Showing dimensions)

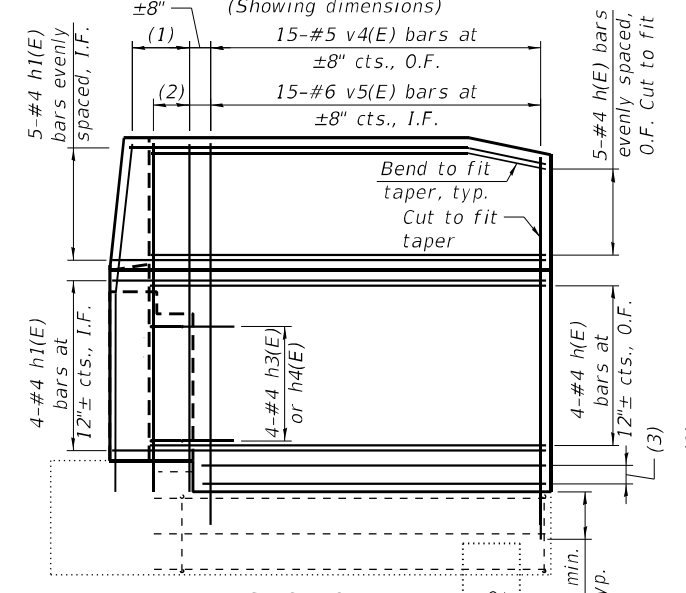

SECTION A-A  
 (Showing reinforcement)

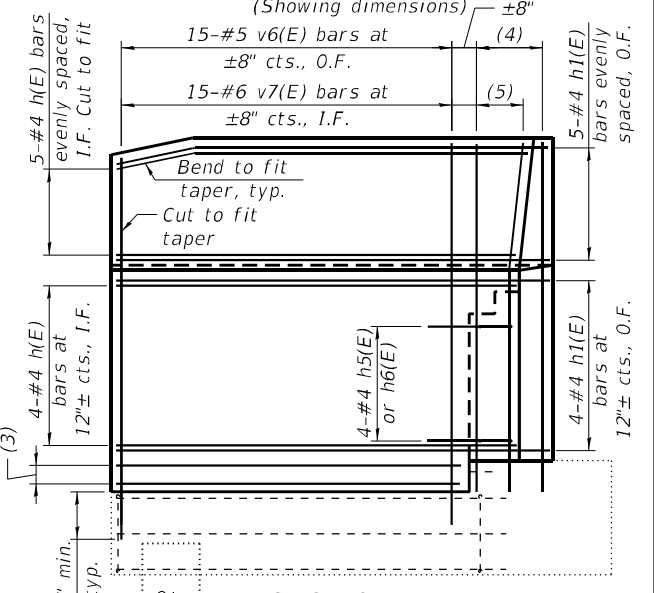

SECTION B-B  
 (Showing reinforcement)

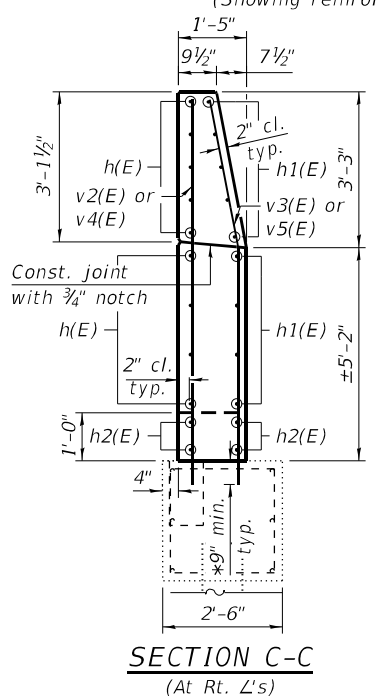

SECTION C-C  
 (At Rt. L's)

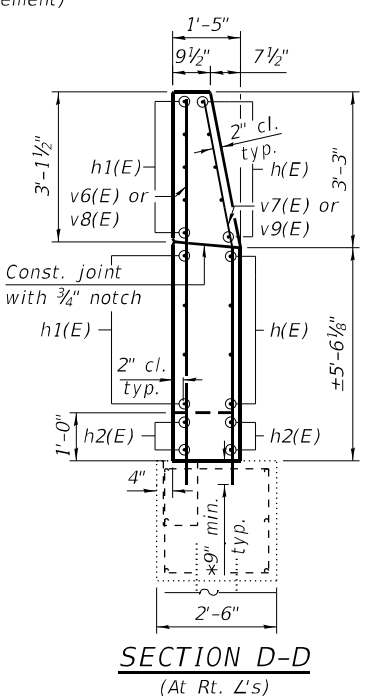

SECTION D-D  
 (At Rt. L's)

BILL OF MATERIAL

Bar	No.	Size	Length	Shape
h(E)	18	#4	10'-11"	—
h1(E)	18	#4	11'-4"	—
h2(E)	8	#4	9'-4"	—
h3(E)	4	#4	4'-10"	↘
h4(E)	4	#4	5'-10"	↘
h5(E)	4	#4	4'-10"	↘
h6(E)	4	#4	5'-10"	↘
v2(E)	3	#5	8'-5"	—
v3(E)	3	#6	8'-6"	—
v4(E)	15	#5	9'-0"	—
v5(E)	15	#6	9'-0"	—
v6(E)	15	#5	9'-4"	—
v7(E)	15	#6	9'-4"	—
v8(E)	3	#5	8'-9"	—
v9(E)	3	#6	8'-9"	—
Structure Excavation			Cu. Yd.	55
Concrete Structures			Cu. Yd.	7.5
Reinforcement Bars, Epoxy Coated			Pound	1,210



USER NAME = J.Cray	DESIGNED - KFO	REVISED -
0480035-68D48-017-S, Abut. Modifications.dgn	CHECKED - KWB	REVISED -
PLOT SCALE = 50.0001" / in.	DRAWN - JDC	REVISED -
PLOT DATE =	CHECKED - MDC	REVISED -

STATE OF ILLINOIS  
 DEPARTMENT OF TRANSPORTATION

SOUTH ABUTMENT MODIFICATION DETAILS  
 STRUCTURE NO. 048-0035  
 SHEET 17 OF 17 SHEETS

F.A.I. RTE.	SECTION	COUNTY	TOTAL SHEETS	SHEET NO.
74	[(72-30;48-29)H8-1]BR	KNOX	115	104
CONTRACT NO. 68D48				
ILLINOIS		FED. AID PROJECT		





# SLOPE STEPS DETAIL

## TYPICAL CROSS-SECTION EMBANKMENT CONSTRUCTION ON SIDEHILL

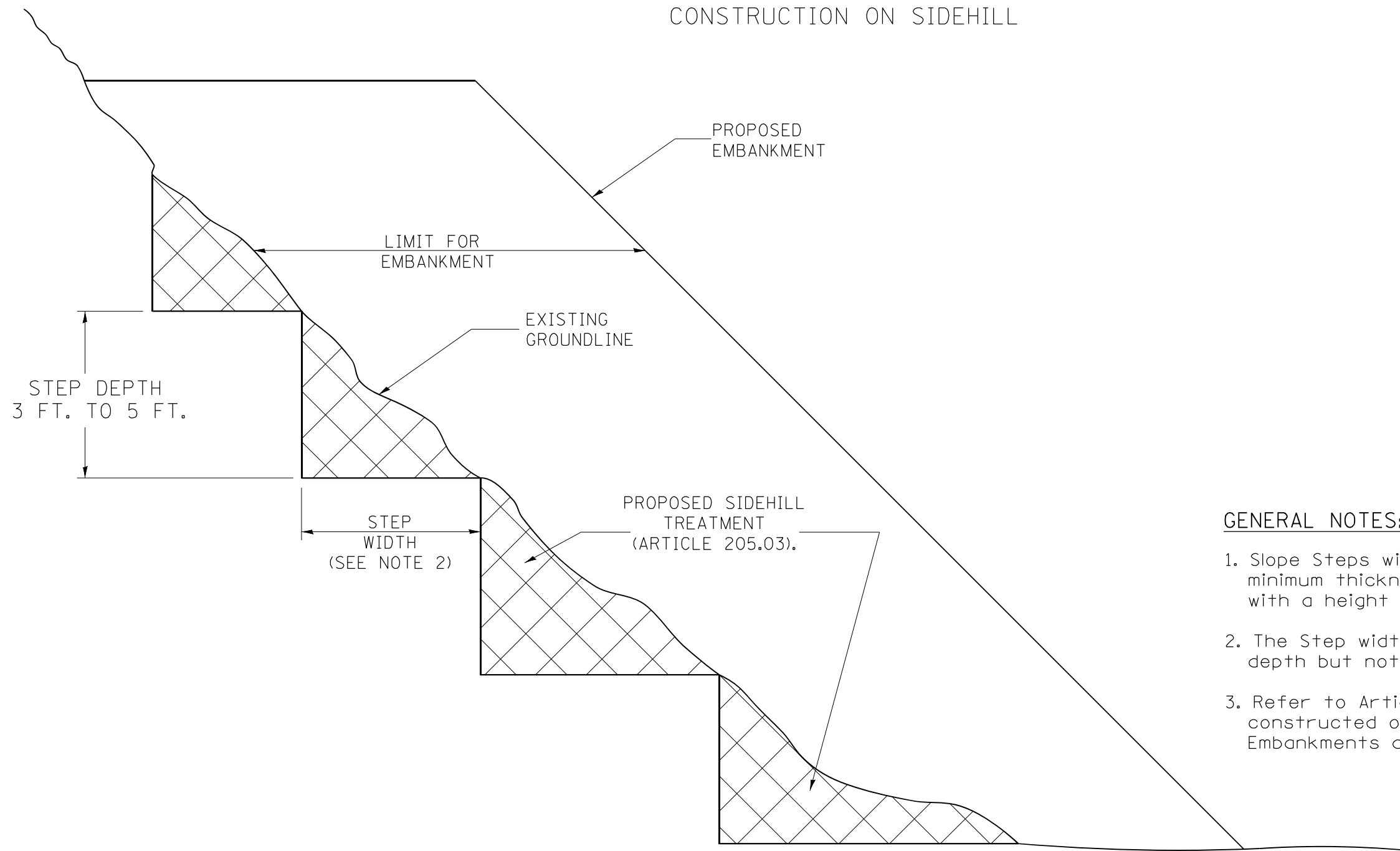

### GENERAL NOTES:

1. Slope Steps will be required for all 12(300) minimum thickness "sliver fills" and on all fills with a height of 10 feet or greater.
2. The Step width shall be twice the Step depth but not less than 6 feet.
3. Refer to Article 205.03 for Embankment to be constructed on Hillside or Slopes, or if existing Embankments are to be widened.

### REPLACEMENT MATERIAL:

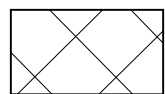

STANDARD EMBANKMENT  
(IN ACCORDANCE WITH  
205 OF THE STANDARD SPECIFICATION).

All dimensions are in inches (millimeters)  
unless otherwise noted.

MODEL: D:\p\h\... FILE NAME: P:\2023\121122\IC - IL 78 over FAI 74 & CH 184 CADD - DWG\4.7 FromCAD\_Sheets\184BDD48.chr=fdpe\_steps\_detail.CH 18.dgn



**TWM, INC.**  
WWW.TWM-INC.COM  
IL DESIGN FIRM  
LICENSE NO:  
184-001220

USER NAME =	bbillhartz
PLOT SCALE =	40,0000 * / in.
PLOT DATE =	10/4/2023

DESIGNED -	REVISD -
DRAWN -	REVISD -
CHECKED -	REVISD -
DATE -	REVISD -

**STATE OF ILLINOIS  
DEPARTMENT OF TRANSPORTATION**

**SLOPE STEPS DETAIL  
CH 18**

SCALE: N.T.S. SHEET 1 OF 1 SHEETS STA. TO STA.

### DISTRICT 4 DETAIL NO. 205001

F.A.I. RTE.	SECTION	COUNTY	TOTAL SHEETS	SHEET NO.
74	[(72-30;48-29)HB-1]BRR	PEORIA & KNOX	115	107
CONTRACT NO. 68D48				
ILLINOIS FED. AID PROJECT				

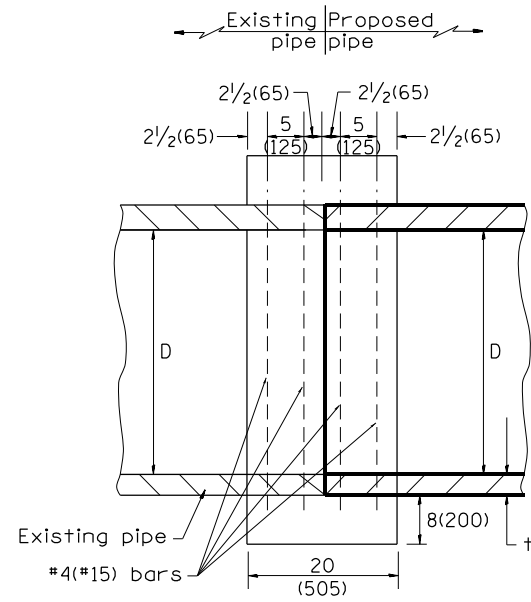

SECTION A - A

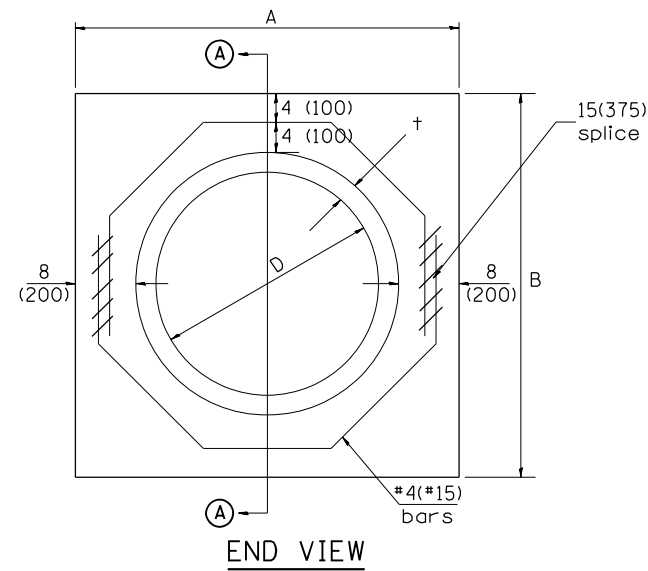

END VIEW

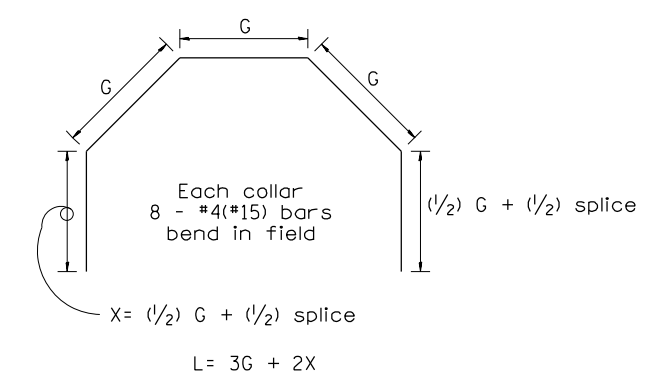

Each Collar								
Reinforcement Bars								
D	t	A	B	CL. SI CONC.	G	X	L	Weight
in (mm)	in (mm)	ft (m)	ft (m)	cu. yd. (m <sup>3</sup> )	in (mm)	in (mm)	ft (m)	lb (kg)
10 (250)	2.00 (51)	2.50 (0.762)	2.50 (0.762)	0.2 (0.138)	9 1/8 (232)	12 1/16 (306)	4.29 (1.308)	23 (10)
12 (300)	2.00 (51)	2.67 (0.814)	2.67 (0.814)	0.4 (0.270)	9 15/16 (253)	12 7/16 (317)	4.57 (1.393)	24 (11)
15 (375)	2.25 (57)	2.96 (0.902)	2.96 (0.902)	0.4 (0.315)	11 3/8 (290)	13 3/16 (335)	5.05 (1.541)	27 (12)
18 (450)	2.50 (64)	3.25 (0.991)	3.25 (0.991)	0.5 (0.362)	12 13/16 (327)	13 7/8 (354)	5.54 (1.689)	30 (14)
21 (525)	2.75 (70)	3.54 (1.079)	3.54 (1.079)	0.5 (0.411)	14 1/4 (364)	14 5/8 (372)	6.02 (1.836)	32 (15)
24 (600)	3.00 (76)	3.83 (1.167)	3.84 (1.167)	0.6 (0.460)	15 11/16 (401)	15 5/16 (391)	6.51 (1.984)	35 (16)
27 (675)	3.25 (83)	4.13 (1.259)	4.13 (1.259)	0.7 (0.516)	17 1/4 (438)	16 1/16 (409)	6.99 (2.131)	37 (17)
30 (750)	3.50 (89)	4.42 (1.347)	4.42 (1.347)	0.7 (0.570)	18 11/16 (475)	16 3/4 (428)	7.48 (2.279)	40 (18)
33 (825)	3.75 (95)	4.71 (1.436)	4.71 (1.436)	0.8 (0.624)	20 1/8 (512)	17 1/2 (446)	7.96 (2.426)	43 (19)
36 (900)	4.00 (102)	5.00 (1.524)	5.00 (1.524)	0.9 (0.682)	21 9/16 (549)	18 3/16 (465)	8.44 (2.574)	45 (20)
42 (1050)	4.50 (114)	5.58 (1.701)	5.58 (1.701)	1.0 (.800)	24 7/16 (622)	19 3/4 (501)	9.41 (2.869)	50 (23)
48 (1200)	5.00 (127)	6.17 (1.881)	6.17 (1.881)	1.2 (0.930)	27 5/16 (696)	21 3/16 (538)	10.38 (3.164)	55 (25)

GENERAL NOTES

1. THE COLLAR SHALL BE CONSTRUCTED ENTIRELY OF CLASS SI CONCRETE IN ACCORDANCE WITH THE APPLICABLE PORTIONS OF SECTION 503 OF THE STANDARD SPECIFICATIONS. REINFORCEMENT BARS SHALL CONFORM TO SECTION 508.
2. This work shall be paid for by the cubic yard (cubic meter) for CONCRETE COLLAR and by the pound (kg) for REINFORCEMENT BARS.

All dimensions are in inches (millimeters) unless otherwise noted.

MODEL: D:\p\112121\112121.dwg; FILE NAME: P:\2002\112121\112121.dwg; USER: RJD; DATE: 2-2-98; CHECKED BY: RDH; DATE: 2-6-98; QUANTITY CALCULATIONS ARE ON FILE AT THE DISTRICT 4 OFFICE; BUREAU OF PROJECT IMPLEMENTATION; DOCUMENTATION SECTION

**QUANTITIES**

CALC. BY: R. J. D. 2-2-98  
 CHECKED BY: R. D. H. 2-6-98

QUANTITY CALCULATIONS ARE ON FILE AT THE DISTRICT 4 OFFICE; BUREAU OF PROJECT IMPLEMENTATION; DOCUMENTATION SECTION

DISTRICT 4 DETAIL NO. 542016 (MODIFIED)				
F.A.I. RTE.	SECTION	COUNTY	TOTAL SHEETS	SHEET NO.
74	[(72-30;48-29)HB-1]BRR	PEORIA & KNOX	115	108
CONTRACT NO. 68D48				
ILLINOIS FED. AID PROJECT				

**TWM**  
 ENGINEERING  
 GEOSPATIAL SERVICES

**TWM, INC.**  
 www.twm-inc.com  
 IL DESIGN FIRM  
 LICENSE NO: 184-001220

USER NAME = bblhartz	DESIGNED -	REVISED -
PLOT SCALE = 100,0000' / in.	DRAWN -	REVISED -
PLOT DATE = 10/4/2023	CHECKED -	REVISED -
	DATE -	REVISED -

**STATE OF ILLINOIS**  
**DEPARTMENT OF TRANSPORTATION**

**PIPE CULVERT EXTENSION COLLAR (WITHOUT END SECTION)**  
**CH 18**

SCALE: N.T.S. SHEET 1 OF 1 SHEETS STA. TO STA.



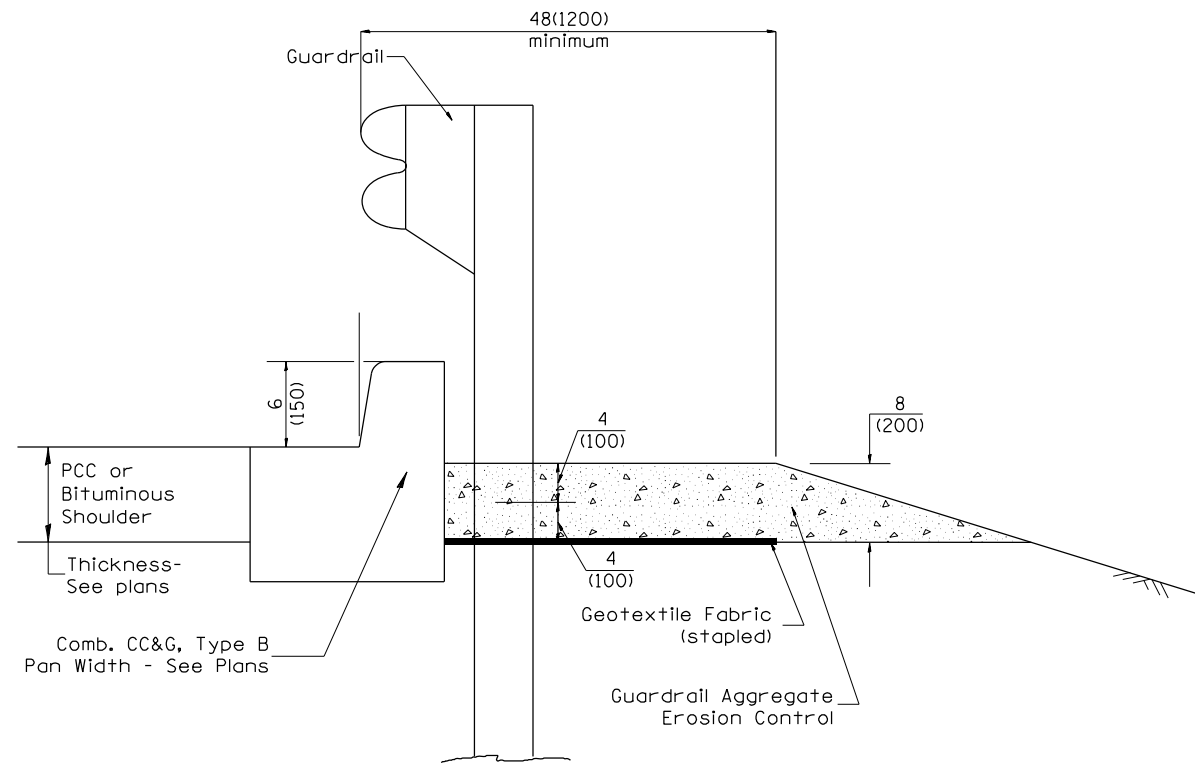

**TYPICAL SECTION WITH COMBINATION CONCRETE CURB & GUTTER**

**GENERAL NOTES: GUARDRAIL AGGREGATE EROSION CONTROL**

1. This work shall consist of grading as needed, furnishing and installing geotextile fabric and staples, and furnishing, placing and shaping crushed aggregate around and behind Steel Plate Beam Guardrail posts in accordance with Plan Details.
2. Before placing the aggregate and the Geotextile Fabric, weeds and grass shall be removed from the area to be covered.
3. After the area has been prepared, and in a dry condition, the Geotextile fabric shall be placed with a 12(300) minimum overlap. A knife cut for guardrail post installation is necessary.
4. The aggregate shall be deposited, compacted and shaped by either mechanical or hand methods, in a manner reasonably true to line and grade.
5. The Contractor shall have the option of placing the guardrail before or after the Geotextile Fabric and Aggregate are in place. If the guardrail is placed after the Geotextile Fabric and Aggregate, then any voids must be filled and the aggregate returned to line and grade.
6. Materials shall meet the following requirements:
  - A. The crushed aggregate shall be CA1 gradation in accordance with Article 1004.01(c) of the Standard Specifications.
  - B. The Geotextile Fabric shall be nonwoven fabric in accordance with Article 1080.02 of the Standard Specifications.

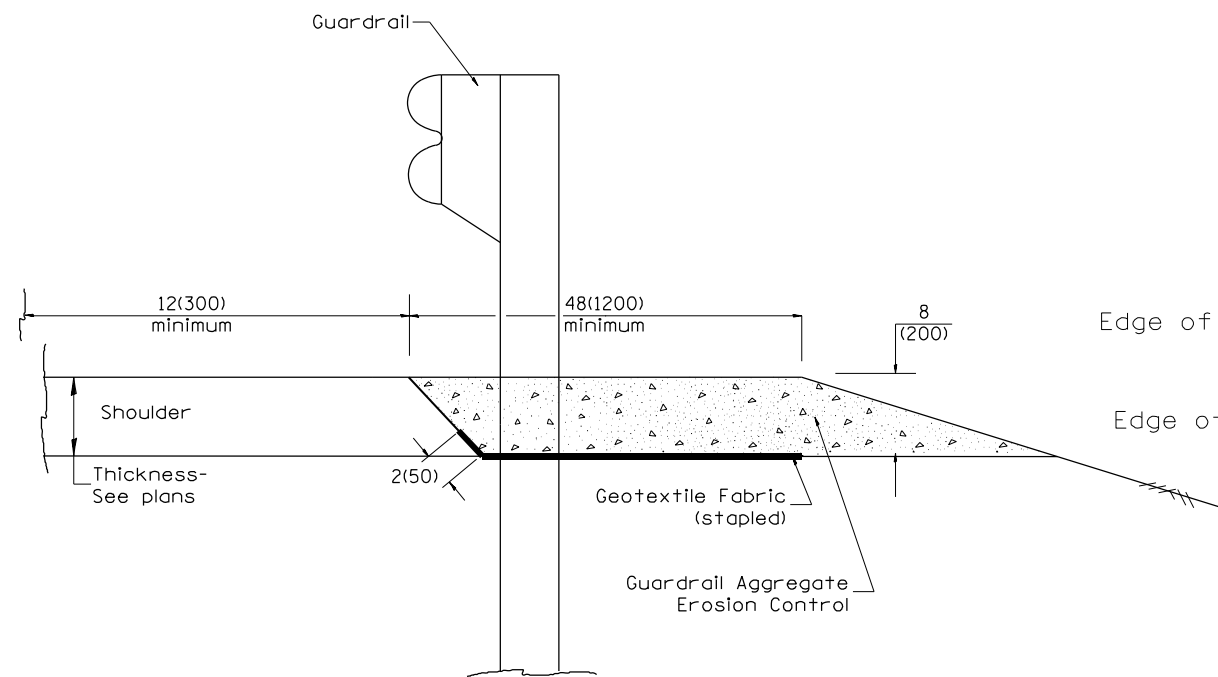

**TYPICAL SECTION WITHOUT EROSION CONTROL CURB**

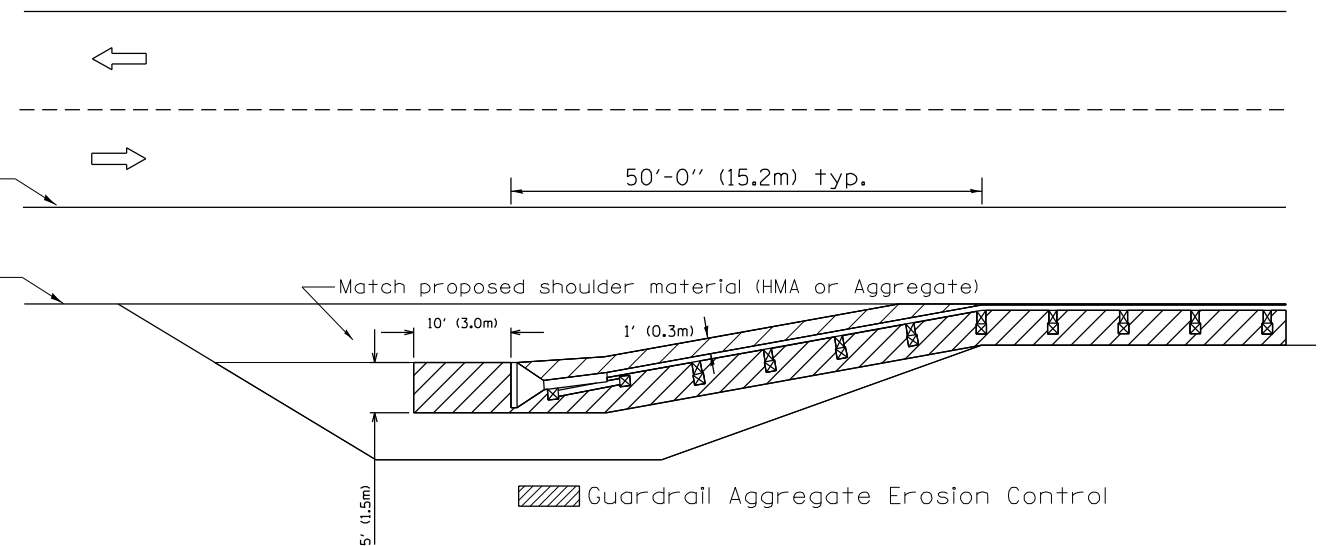

All dimensions are in inches (millimeters) unless otherwise noted.

MODEL Path: \\... \Twm\CAD\_Sheets\184-001220-CH-18.dwg - DWG47\_Twm\CAD\_Sheets\184-001220-CH-18.dwg



**TWM, INC.**  
www.twm-inc.com  
IL DESIGN FIRM  
LICENSE NO: 184-001220

USER NAME = bbillhartz  
PLOT SCALE = 100,0000' / in.  
PLOT DATE = 10/4/2023

DESIGNED -  
DRAWN -  
CHECKED -  
DATE -

REVISED -  
REVISED -  
REVISED -  
REVISED -

**STATE OF ILLINOIS  
DEPARTMENT OF TRANSPORTATION**

**GUARDRAIL EROSION CONTROL TREATMENTS  
CH 18**

SCALE: N.T.S. SHEET 1 OF 1 SHEETS STA. TO STA.

**DISTRICT 4 DETAIL NO. 630101**

F.A.I. RTE.	SECTION	COUNTY	TOTAL SHEETS	SHEET NO.
74	[(72-30;48-29)HB-1]BRR	PEORIA & KNOX	115	109
CONTRACT NO. 68D48				
ILLINOIS FED. AID PROJECT				

FINAL SURVEY NO.	SURVEYED	BY	DATE
NOTE BOOK	PLOTTED		
AREAS CHECKED	TEMPLATE		
	AREAS CHECKED		

ORIGINAL SURVEY NO.	SURVEYED	BY	DATE
NOTE BOOK	PLOTTED		
AREAS CHECKED	TEMPLATE		
	AREAS CHECKED		

MODEL: Definit  
 FILE NAME: P:\2021\12\1221\16 - IL 78 over FAI 74 & CH 184 CADD - DWG\17. TransCAD\_Sheets\4488D48-xxsh-CH18.dgn

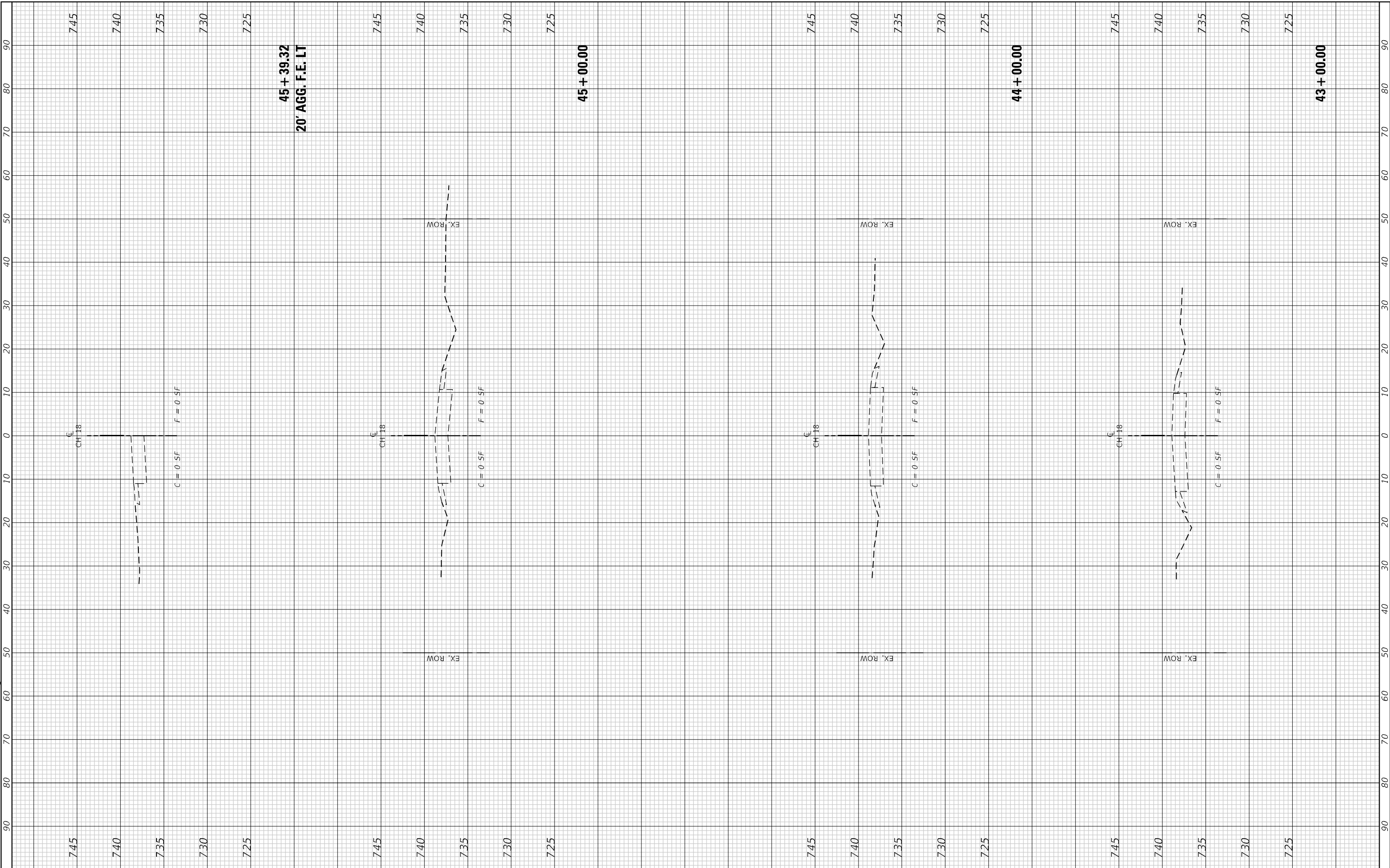

**TWM**  
 ENGINEERING  
 GEOSPATIAL SERVICES

**TWM, INC.**  
 www.twm-inc.com  
 IL DESIGN FIRM  
 LICENSE NO:  
 184-001220

USER NAME =	bbillhartz
PLOT SCALE =	20.0000' / in.
PLOT DATE =	10/4/2023

DESIGNED -	
DRAWN -	
CHECKED -	
DATE -	

REVISED -	
REVISED -	
REVISED -	
REVISED -	

**STATE OF ILLINOIS  
 DEPARTMENT OF TRANSPORTATION**

SCALE: 1"=10'	SHEET 1	OF 6	SHEETS	STA. 43+00.00	TO STA. 45+00.00
---------------	---------	------	--------	---------------	------------------

**CROSS SECTIONS  
 CH 18**

F.A.I. RTE.	SECTION	COUNTY	TOTAL SHEETS	SHEET NO.
74	[(72-30;48-29)HB-1]BRR	PEORIA & KNOX	115	110
CONTRACT NO. 68D48				
		ILLINOIS	FED. AID PROJECT	



FINAL SURVEY NO.	SURVEYED	BY	DATE
NOTE BOOK	PLOTTED		
AREAS CHECKED	TEMPLATE		
AREAS CHECKED	AREAS		
	AREAS CHECKED		

ORIGINAL SURVEY NO.	SURVEYED	BY	DATE
NOTE BOOK	PLOTTED		
AREAS CHECKED	TEMPLATE		
AREAS CHECKED	AREAS		
AREAS CHECKED	AREAS CHECKED		

MODEL: Definit  
 FILE NAME: P:\2021\12\1221\16 - IL 78 over FAI 74 & CH 18.dwg  
 CH 18.dwg  
 DWG/G77

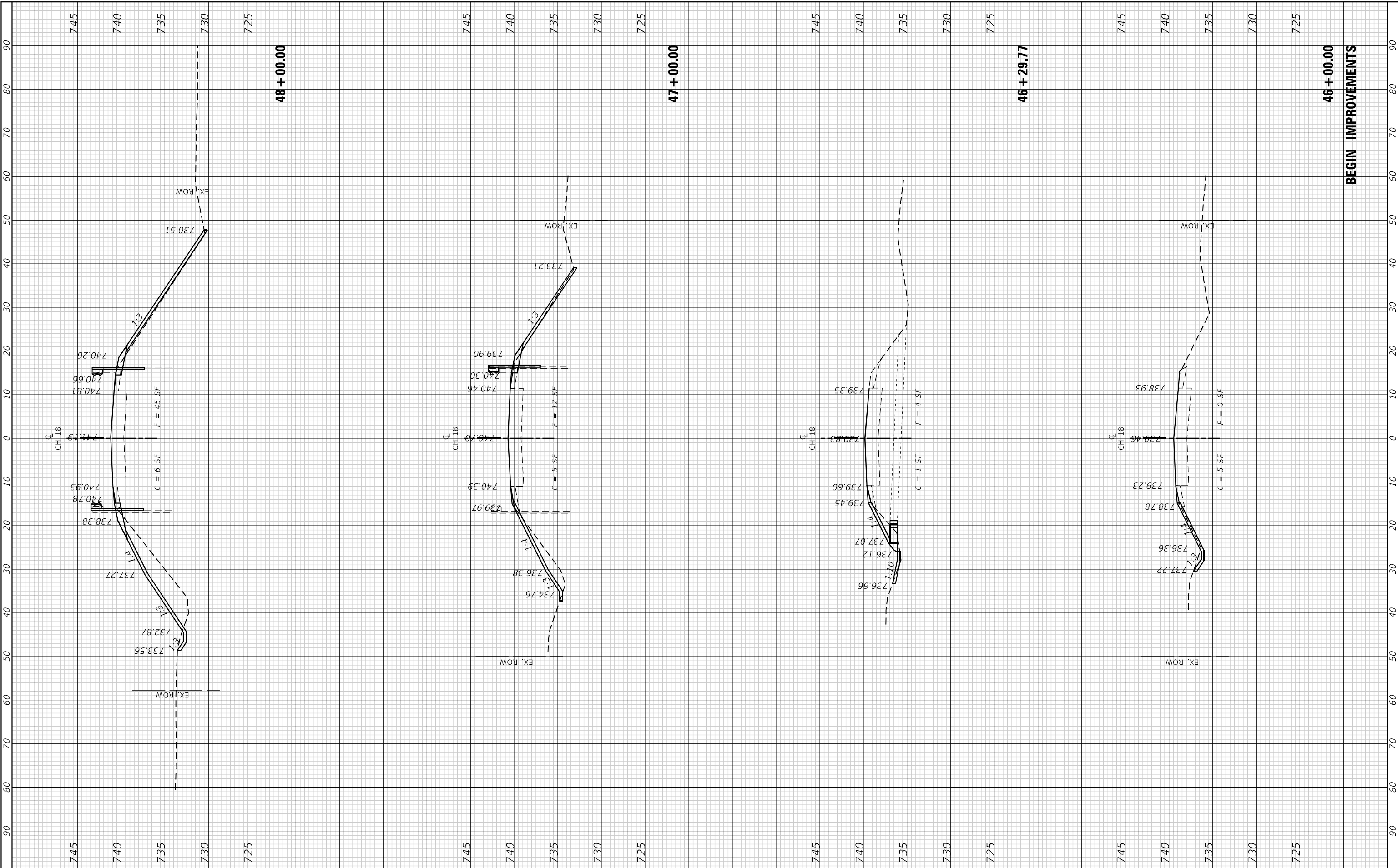

**TWM**  
 ENGINEERING  
 GEOSPATIAL SERVICES

**TWM, INC.**  
 www.twm-inc.com  
 IL DESIGN FIRM  
 LICENSE NO:  
 184-001220

USER NAME =	bbillhartz
PLOT SCALE =	20.0000' / in.
PLOT DATE =	10/4/2023

DESIGNED -	
DRAWN -	
CHECKED -	
DATE -	

REVISED -	
REVISED -	
REVISED -	
REVISED -	

**STATE OF ILLINOIS  
 DEPARTMENT OF TRANSPORTATION**

SCALE: 1"=10'	SHEET 2	OF 6	SHEETS	STA. 46+00.00	TO STA. 48+00.00
---------------	---------	------	--------	---------------	------------------

F.A.I. RTE. 74	SECTION [(72-30;48-29)HB-1]BRR	COUNTY PEORIA & KNOX	TOTAL SHEETS 115	SHEET NO. 111
CONTRACT NO. 68D48			ILLINOIS FED. AID PROJECT	

FINAL SURVEY NO.	SURVEYED	BY	DATE
NOTE BOOK	PLOTTED		
AREAS CHECKED	TEMPLATE		
AREAS CHECKED	AREAS CHECKED		

ORIGINAL SURVEY NO.	SURVEYED	BY	DATE
NOTE BOOK	PLOTTED		
AREAS CHECKED	TEMPLATE		
AREAS CHECKED	AREAS CHECKED		

MODEL: Definit  
 FILE NAME: P:\2021\121221\16 - IL 78 over FAI 74 & CH 184 CADD - DWG\67\_TrimCAD\_Sheets\68D48-ss-hb-CH18.dgn

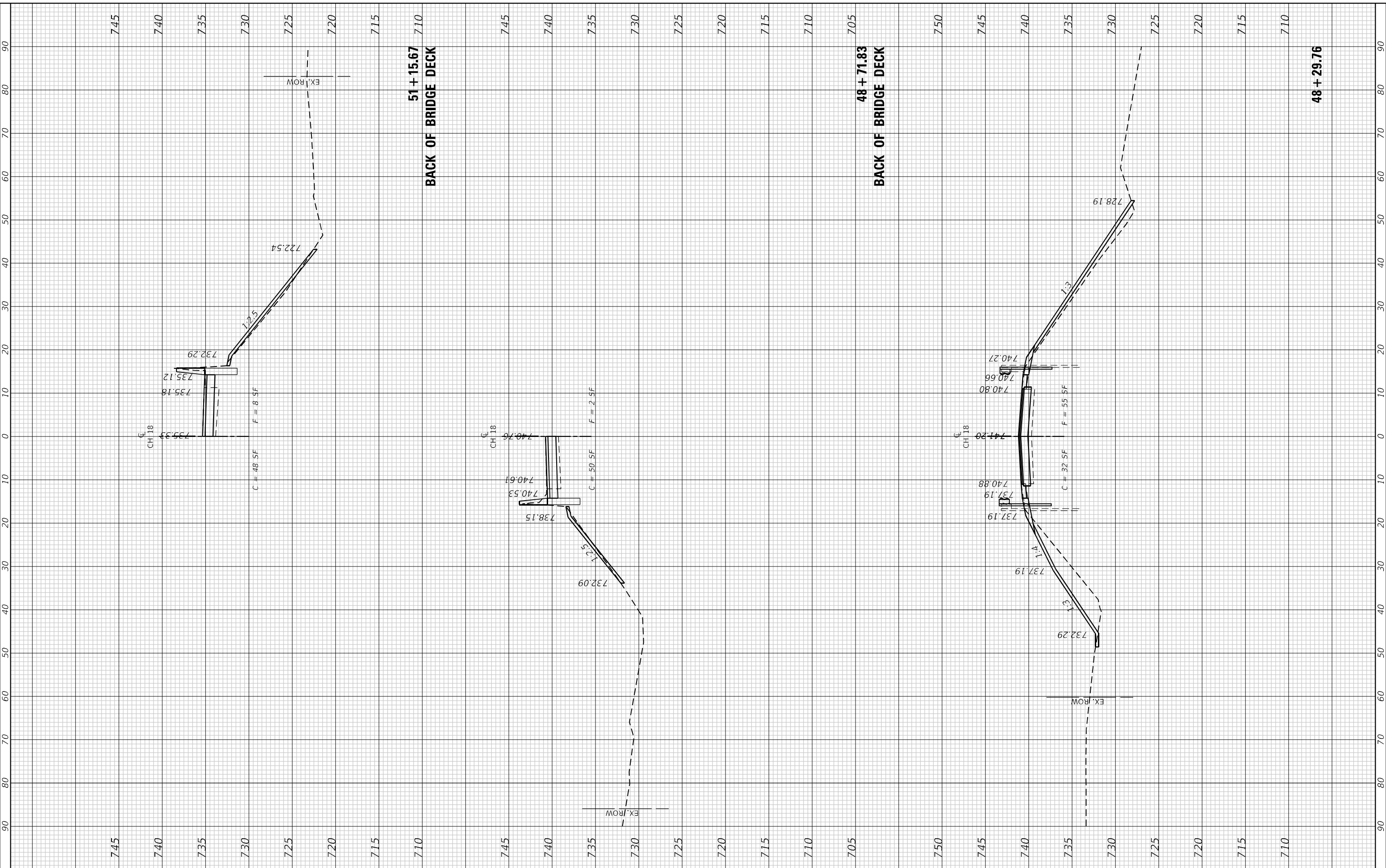

**TWM**  
 ENGINEERING  
 GEOSPATIAL SERVICES

**TWM, INC.**  
 www.twm-inc.com  
 IL DESIGN FIRM  
 LICENSE NO:  
 184-001220

USER NAME =	bbillhartz
PLOT SCALE =	20,0000 * / in.
PLOT DATE =	10/4/2023

DESIGNED -	REVISIED -
DRAWN -	REVISIED -
CHECKED -	REVISIED -
DATE -	REVISIED -

DESIGNED -	REVISIED -
DRAWN -	REVISIED -
CHECKED -	REVISIED -
DATE -	REVISIED -

**STATE OF ILLINOIS  
 DEPARTMENT OF TRANSPORTATION**

**CROSS SECTIONS  
 CH 18**

SCALE: 1"=10'    SHEET 3 OF 6 SHEETS    STA. 48+29.76 TO STA. 51+15.75

F.A.I. RTE.	SECTION	COUNTY	TOTAL SHEETS	SHEET NO.
74	[(72-30;48-29)HB-1]BRR	PEORIA & KNOX	115	112
				CONTRACT NO. 68D48
				ILLINOIS FED. AID PROJECT

FINAL SURVEY NO.	SURVEYED	BY	DATE
NOTE BOOK	PLOTTED		
AREAS CHECKED	TEMPLATE		
AREAS CHECKED	AREAS CHECKED		

ORIGINAL SURVEY NO.	SURVEYED	BY	DATE
NOTE BOOK	PLOTTED		
AREAS CHECKED	TEMPLATE		
AREAS CHECKED	AREAS CHECKED		

MODEL: Definit  
 FILE NAME: P:\2021\12\1221\1C - IL 78 over FAI 74 & CH 184 CADD - DWG\67\_TrimCAD\_Sheets\68D48\sssh-CH18.dgn

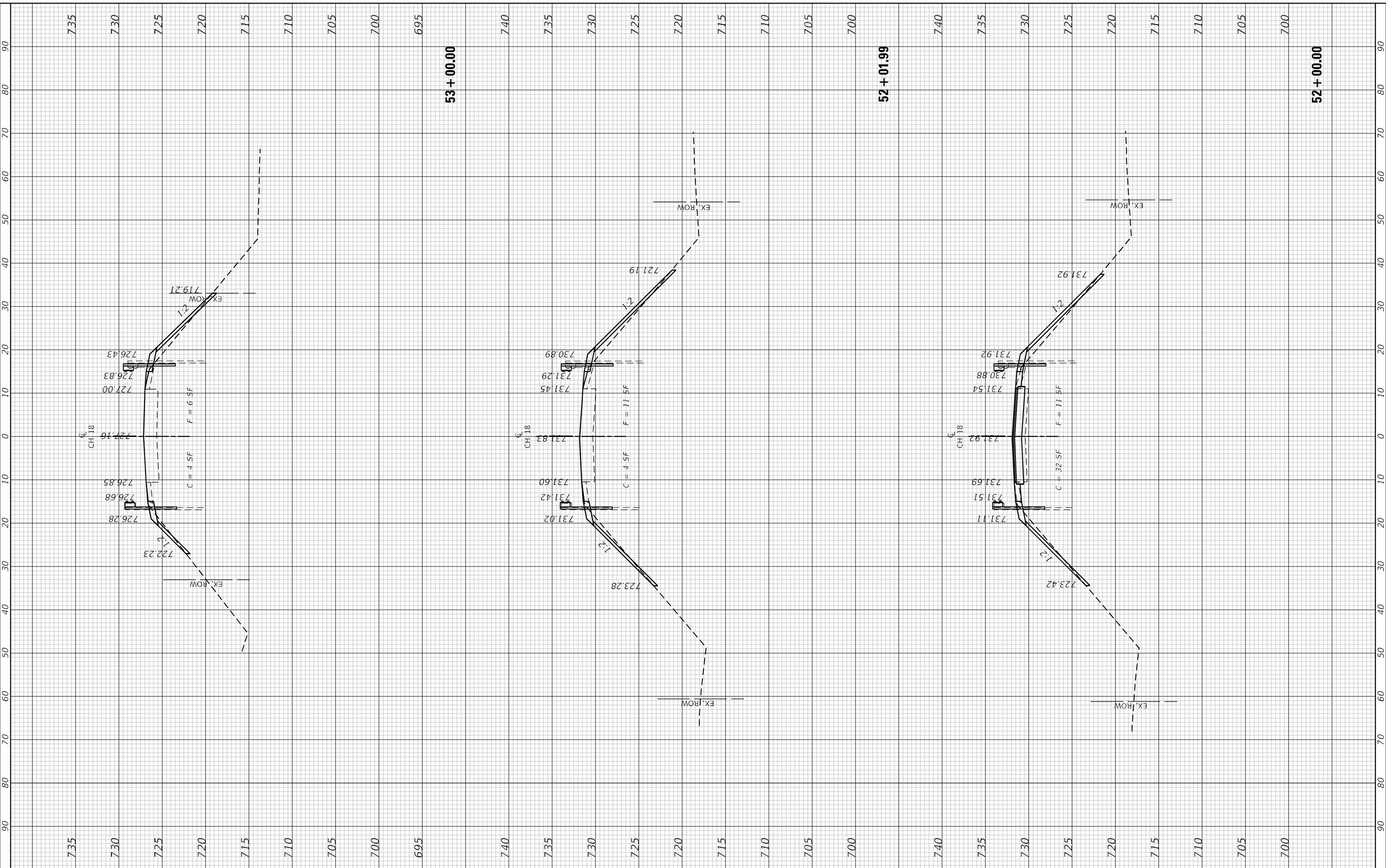

**TWM**  
 ENGINEERING  
 GEOSPATIAL SERVICES

**TWM, INC.**  
 www.twm-inc.com  
 IL DESIGN FIRM  
 LICENSE NO:  
 184-001220

USER NAME =	bbillhartz
DESIGNED -	
DRAWN -	
CHECKED -	
DATE -	
PLOT SCALE =	20.0000' / in.
PLOT DATE =	10/4/2023

REVISED -	
REVISED -	
REVISED -	
REVISED -	

**STATE OF ILLINOIS  
 DEPARTMENT OF TRANSPORTATION**

**CROSS SECTIONS  
 CH 18**

SCALE: 1"=10'    SHEET 4 OF 6 SHEETS    STA. 52+00.00 TO STA. 53+00.00

F.A.I. RTE.	SECTION	COUNTY	TOTAL SHEETS	SHEET NO.
74	[(72-30;48-29)HB-1]BRR	PEORIA & KNOX	115	113
CONTRACT NO. 68D48				
ILLINOIS FED. AID PROJECT				

MODEL: Definit  
 FILE NAME: P:\2021\1212\16 - IL 78 over FAI 74 & CH 184 CADD - DWG\67 Trm\CAD\_Sheets\68D48\ssb\ch-18.dgn

FINAL SURVEY NO.	SURVEYED	BY	DATE
NOTE BOOK	PLOTTED		
AREAS CHECKED	TEMPLATE		
	AREAS		
	AREAS CHECKED		

ORIGINAL SURVEY NO.	SURVEYED	BY	DATE
NOTE BOOK	PLOTTED		
AREAS CHECKED	TEMPLATE		
	AREAS		
	AREAS CHECKED		

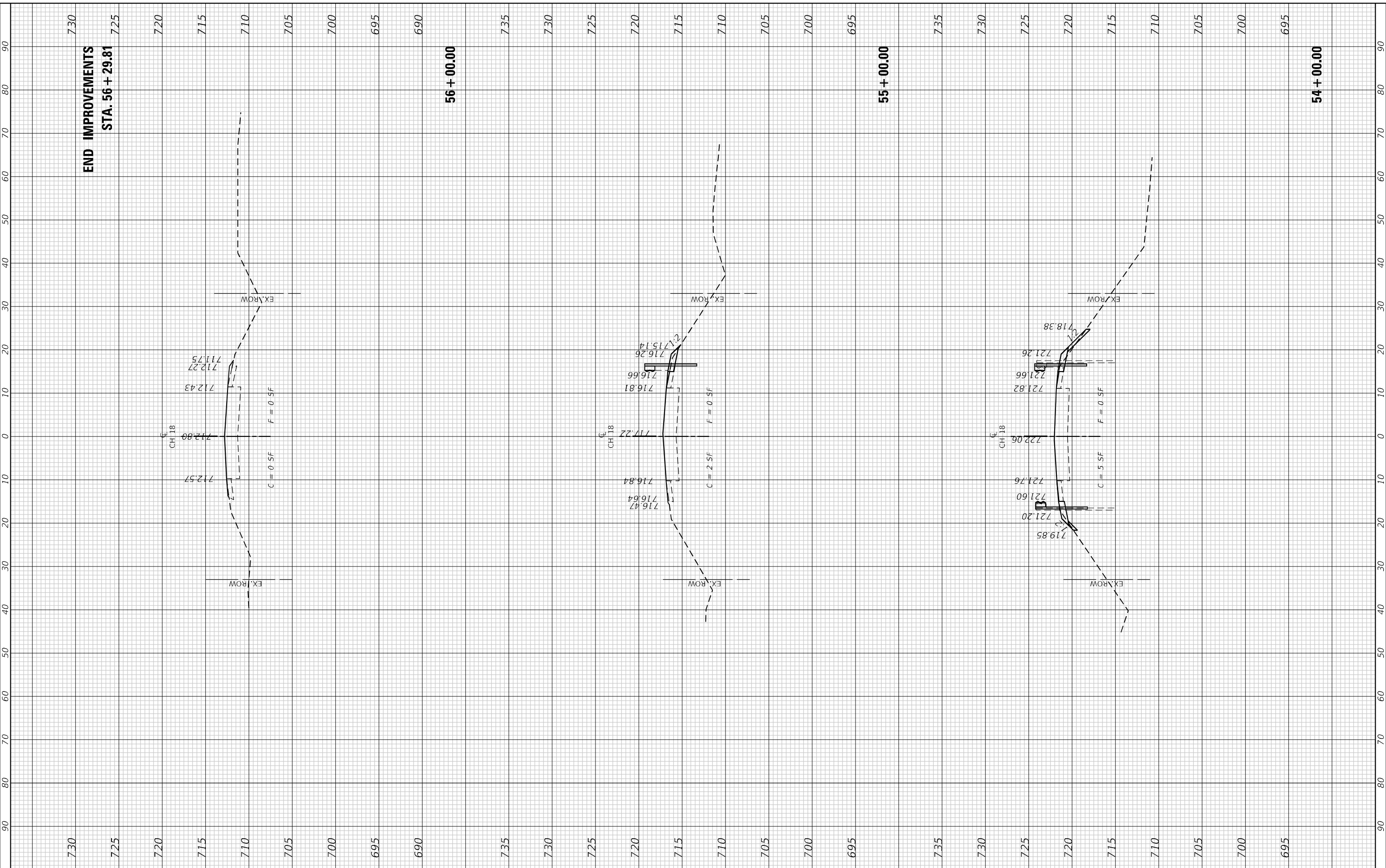

	USER NAME = bbillhartz PLOT SCALE = 20.0000' / in. PLOT DATE = 10/4/2023	DESIGNED - DRAWN - CHECKED - DATE -	REVISED - REVISED - REVISED - REVISED -	<b>STATE OF ILLINOIS          DEPARTMENT OF TRANSPORTATION</b>	<b>CROSS SECTIONS          CH 18</b>	SCALE: 1"=10' SHEET 5 OF 6 SHEETS STA. 54+00.00 TO STA. 56+00.00	F.A.I. RTE. 74 SECTION [(72-30;48-29)HB-1]BRR COUNTY PEORIA & KNOX CONTRACT NO. 68D48	TOTAL SHEETS 115 SHEET NO. 114	ILLINOIS FED. AID PROJECT
	END IMPROVEMENTS STA. 56 + 29.81		<b>56 + 00.00</b>			<b>55 + 00.00</b>		<b>54 + 00.00</b>	

FINAL SURVEY NO.	SURVEYED PLOTTED AREAS CHECKED	BY	DATE
NOTE BOOK	TEMPLATE		
	AREAS CHECKED		

ORIGINAL SURVEY NO.	SURVEYED PLOTTED AREAS CHECKED	BY	DATE

MODEL: Definit  
FILE NAME: P:\2021\1212\116 - IL 78 over FAI 74 & CH 184 CADD - DWG\67 Trm\CAD\_Sheets\68D48-ss-hc-CH18.dgn

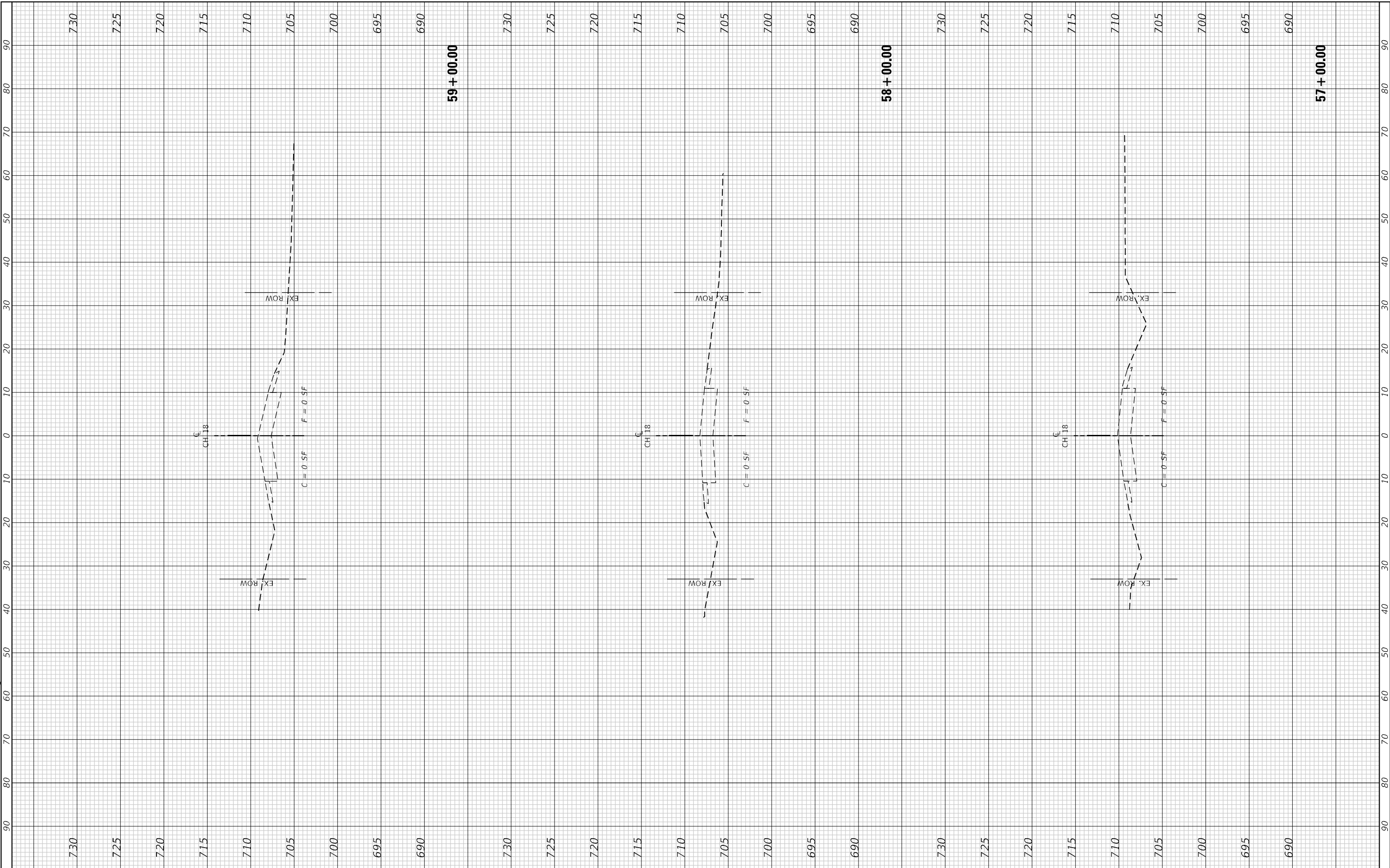

**TWM** ENGINEERING GEOSPATIAL SERVICES  
**TWM, INC.** www.twm-inc.com  
IL DESIGN FIRM LICENSE NO: 184-001220

USER NAME = bbillhartz	DESIGNED -	REVISED -
PLOT SCALE = 20,0000 * / in.	DRAWN -	REVISED -
PLOT DATE = 10/4/2023	CHECKED -	REVISED -
	DATE -	REVISED -

**STATE OF ILLINOIS  
DEPARTMENT OF TRANSPORTATION**

**CROSS SECTIONS  
CH 18**

SCALE: 1"=10'    SHEET 6 OF 6 SHEETS    STA. 57+00.00 TO STA. 59+00.00

F.A.I. RTE.	SECTION	COUNTY	TOTAL SHEETS	SHEET NO.
74	[(72-30;48-29)HB-1]BRR	PEORIA & KNOX	115	115
CONTRACT NO. 68D48				
ILLINOIS FED. AID PROJECT				