

OUTSIDE SHOULDER INSTALLATIONS

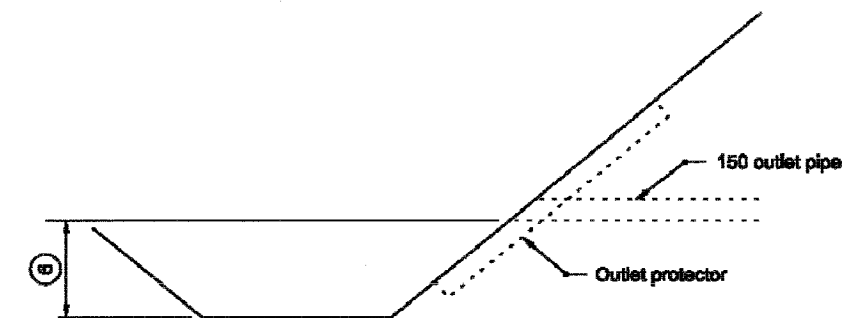

DITCH OUTLET DETAIL

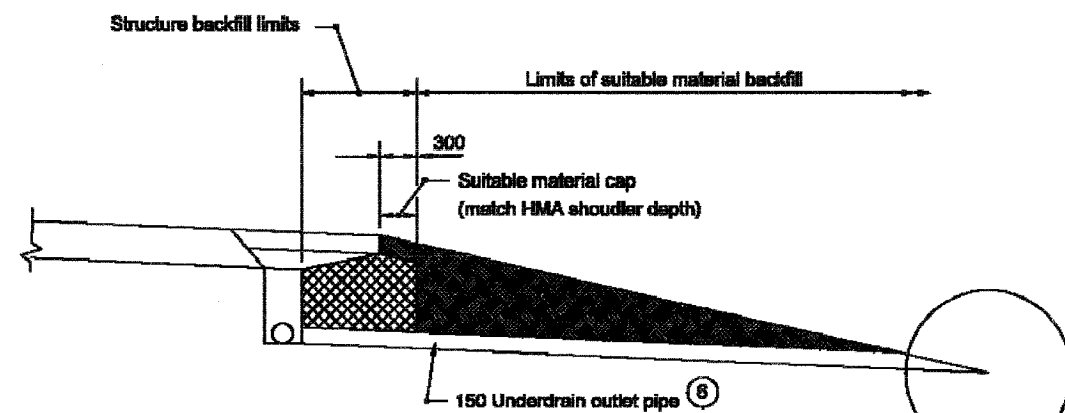

MEDIAN SHOULDER INSTALLATIONS

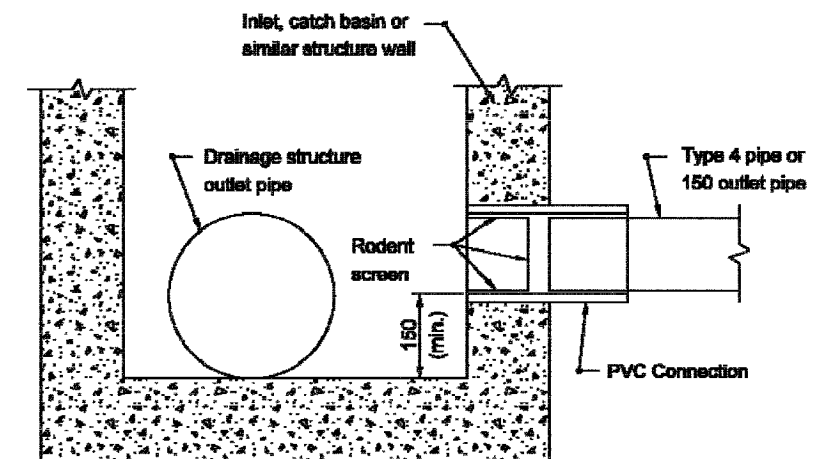

DRAINAGE STRUCTURE OUTLET DETAIL

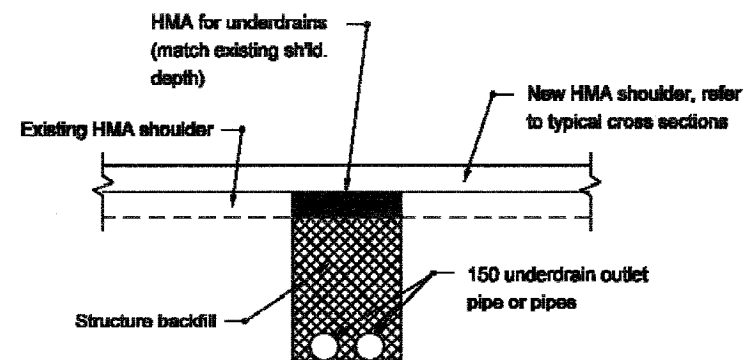

RETROFIT UNDERDRAIN OUTLET DETAIL (UNDER PAVED SHOULDER)

NOTE:

1. Standard Drawing 718-UNDR-07 for General Notes pertaining to this sheet.

All Dimension are in mm unless otherwise specified

| | | | | | | | | | |
|--------------------------------------|---|--------------------------|---------|---------------------------|------|------------------------|---------|------------------------|------|
| INDIANA DEPARTMENT OF TRANSPORTATION | | | | | | | | | |
| UNDERDRAIN DETAILS | | | | | | | | | |
| MARCH 2003 | | | | | | | | | |
| STANDARD DRAWING NO. 718-UNDR-02 | | | | | | | | | |
| | <table border="0" style="width: 100%;"> <tr> <td>/s/ Anthony L. Uremowich</td> <td>3-03-03</td> </tr> <tr> <td>DESIGN STANDARDS ENGINEER</td> <td>DATE</td> </tr> <tr> <td>/s/ Richard K. Smutzer</td> <td>3-03-03</td> </tr> <tr> <td>CHIEF HIGHWAY ENGINEER</td> <td>DATE</td> </tr> </table> | /s/ Anthony L. Uremowich | 3-03-03 | DESIGN STANDARDS ENGINEER | DATE | /s/ Richard K. Smutzer | 3-03-03 | CHIEF HIGHWAY ENGINEER | DATE |
| /s/ Anthony L. Uremowich | 3-03-03 | | | | | | | | |
| DESIGN STANDARDS ENGINEER | DATE | | | | | | | | |
| /s/ Richard K. Smutzer | 3-03-03 | | | | | | | | |
| CHIEF HIGHWAY ENGINEER | DATE | | | | | | | | |
| DESIGN STANDARDS ENGINEER | | | | | | | | | |