

F.A.I. RTE.	SECTION	COUNTY	TOTAL SHEETS	SHEET NO.
80/94	2626.2-R-2	COOK/LAKE	1207	419
STA.	TO STA.			
FED. ROAD DIST. NO.	ILLINOIS	FED. AID PROJECT		
CONTRACT NO. 62114	INDOT DES. NO. 0100987			

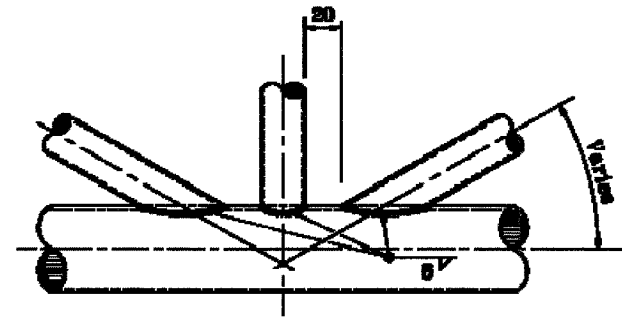

**DETAIL A  
PANEL CONNECTION**

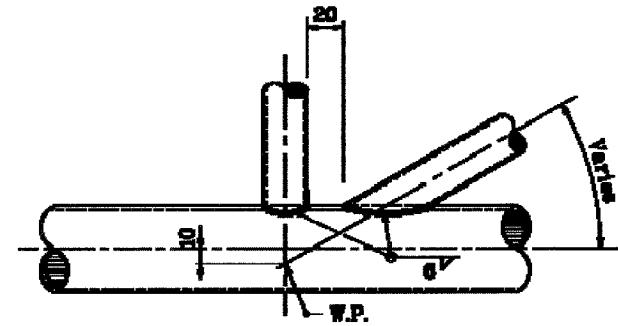

**DETAIL B  
PANEL CONNECTION**

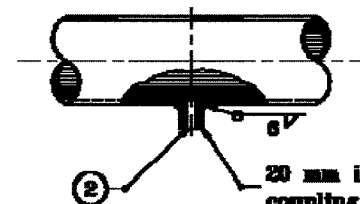

**DETAIL C  
WIRE OUTLET**

20 mm inside diameter aluminum coupling welded into hole in chord

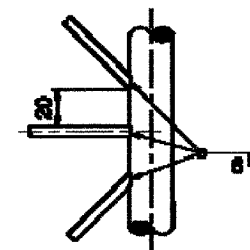

**TYPICAL WELD DETAIL**

**GENERAL NOTES**

- All bracing members shall be machined to provide a snug fit to the chord members along the entire edge of bracing members before welding.
- Drill 25 dia. hole in chord-round edges.

All dimensions are in mm unless otherwise specified.

INDIANA DEPARTMENT OF TRANSPORTATION

**ALUMINUM STRUCTURE  
DETAILS**

SEPTEMBER 2001

STANDARD DRAWING NO. 002-SNOH-05

	<i>/s/ Anthony L. Brumback</i> 9-01-01 REGISTERED PROFESSIONAL ENGINEER    DATE:
	<i>/s/ Steve Smith</i> 9-01-01 CHIEF REGISTERED ENGINEER    DATE: