

F.A.I. RTE.	SECTION	COUNTY	TOTAL SHEETS	SHEET NO.
80/94	2626.2-R-2	COOK	1207	1101
STA.		TO STA.		
FED. ROAD DIST. NO.		ILLINOIS	FED. AID PROJECT	
CONTRACT NO. 62114		INDOT DES. NO 0100987		

FINAL SURVEY	DATE
SURVEYED	BY
NOTE BOOK	
NO.	
AREAS CHECKED	

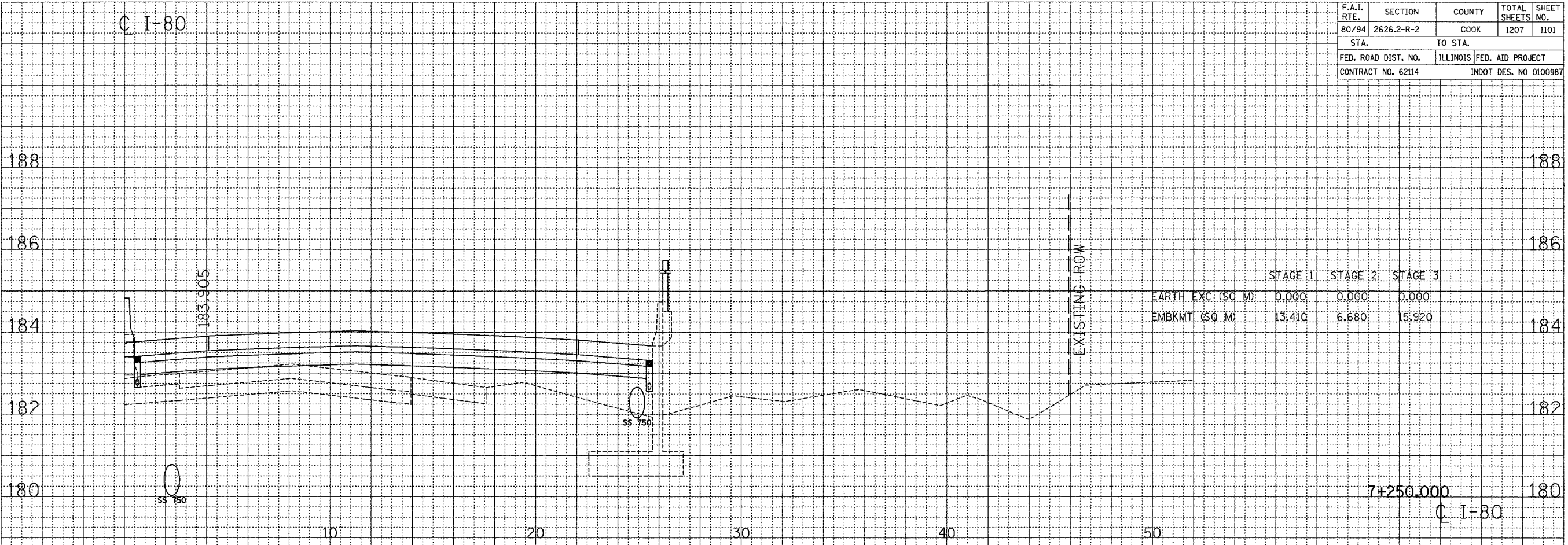

ORIGINAL SURVEY	DATE
SURVEYED	BY
NOTE BOOK	
NO.	
AREAS CHECKED	

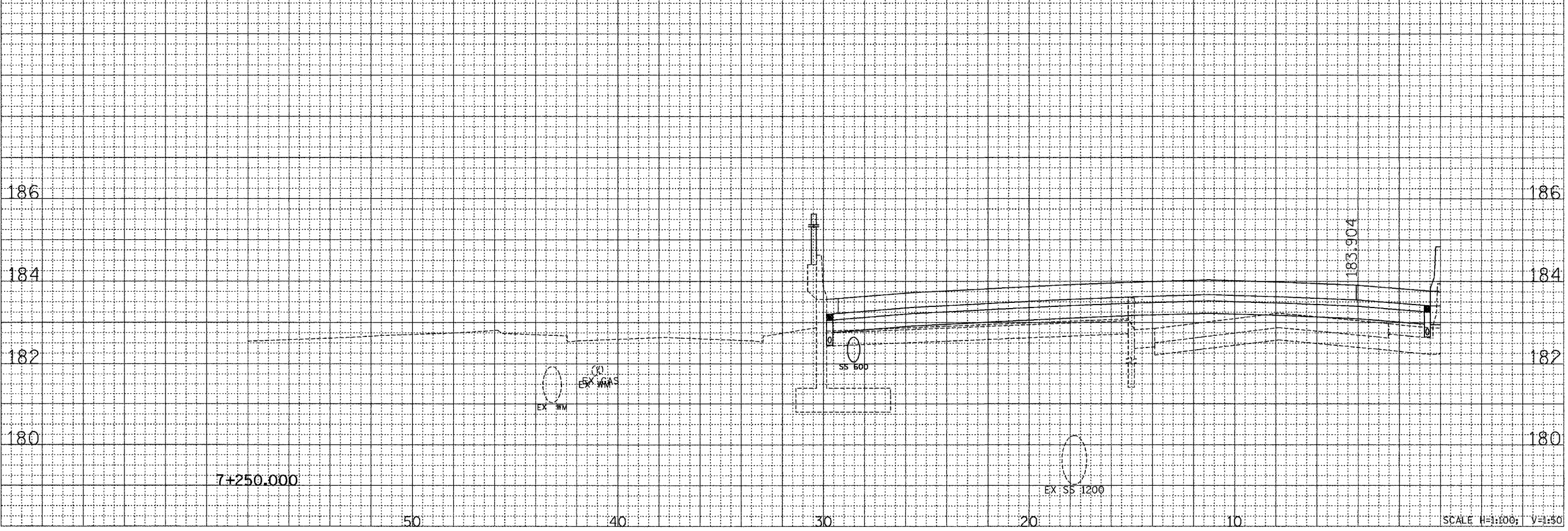

CROSS SECTION - I-80/94/US 6

Scale H=1:100; V=1:50

C I-80

F.A.I. RTE.	SECTION	COUNTY	TOTAL SHEETS	SHEET NO.
80/94	2626.2-R-2	COOK	1207	1102
STA.		TO STA.		
FED. ROAD DIST. NO.		ILLINOIS FED. AID PROJECT		
CONTRACT NO. 62114		INDOT DES. NO 0100987		

FINAL SURVEY	DATE
BY	
SURVEYED	
PLOTTED	
NOTE BOOK	
AREAS	
CHECKED	
NO.	

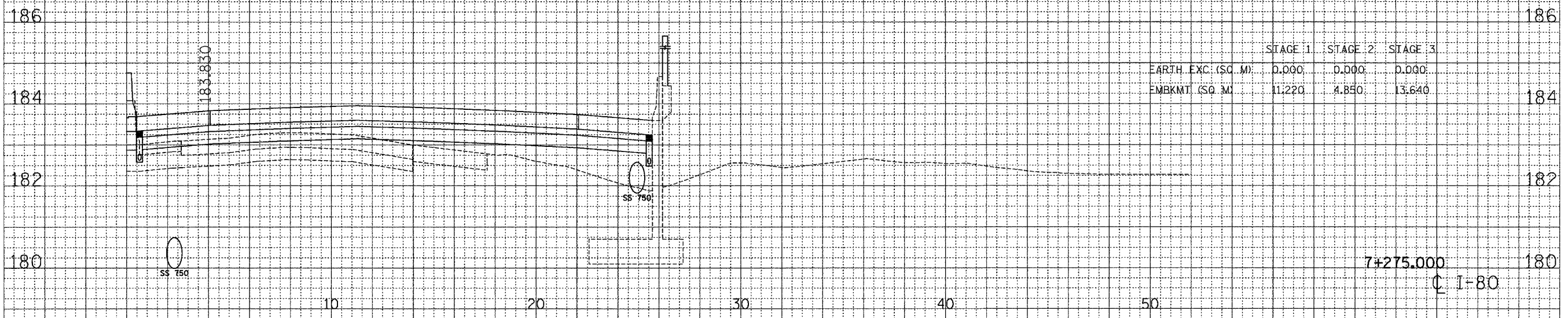

ORIGINAL SURVEY	DATE
BY	
SURVEYED	
PLOTTED	
NOTE BOOK	
AREAS	
CHECKED	
NO.	

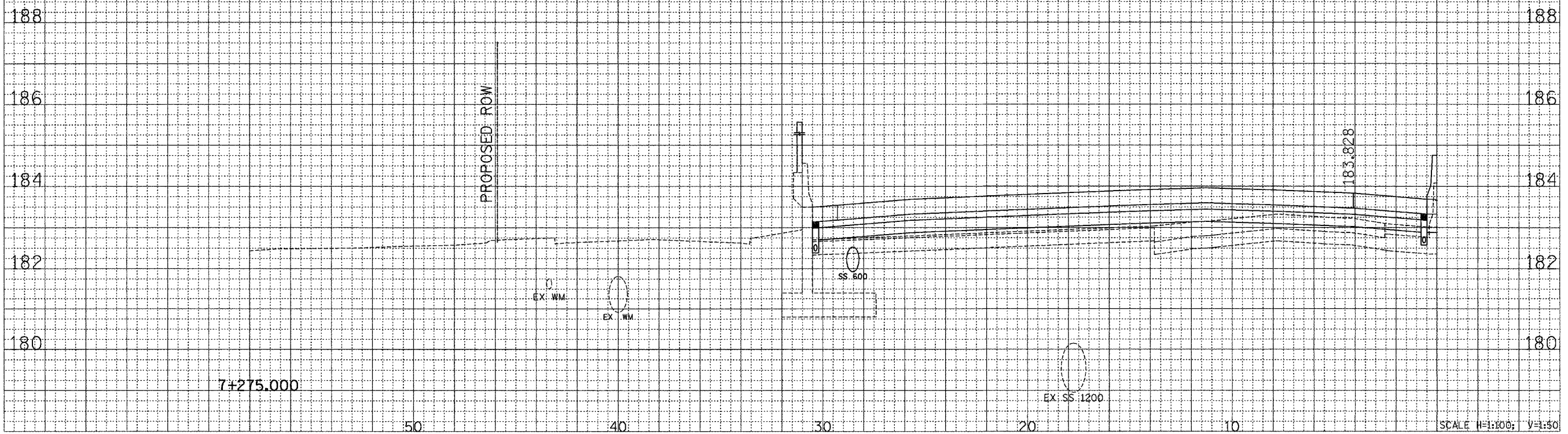

CROSS SECTION - I-80/94/US 6

...:Amicus\us10611a.rvt 09/15/2005 09:46:30 AM

F.A.I. RTE. 80/94	SECTION 2626.2-R-2	COUNTY COOK	TOTAL SHEETS 1207	SHEET NO. 1103
STA. FED. ROAD DIST. NO. 62114		TO STA. ILLINOIS FED. AID PROJECT INDOT DES. NO 0100987		

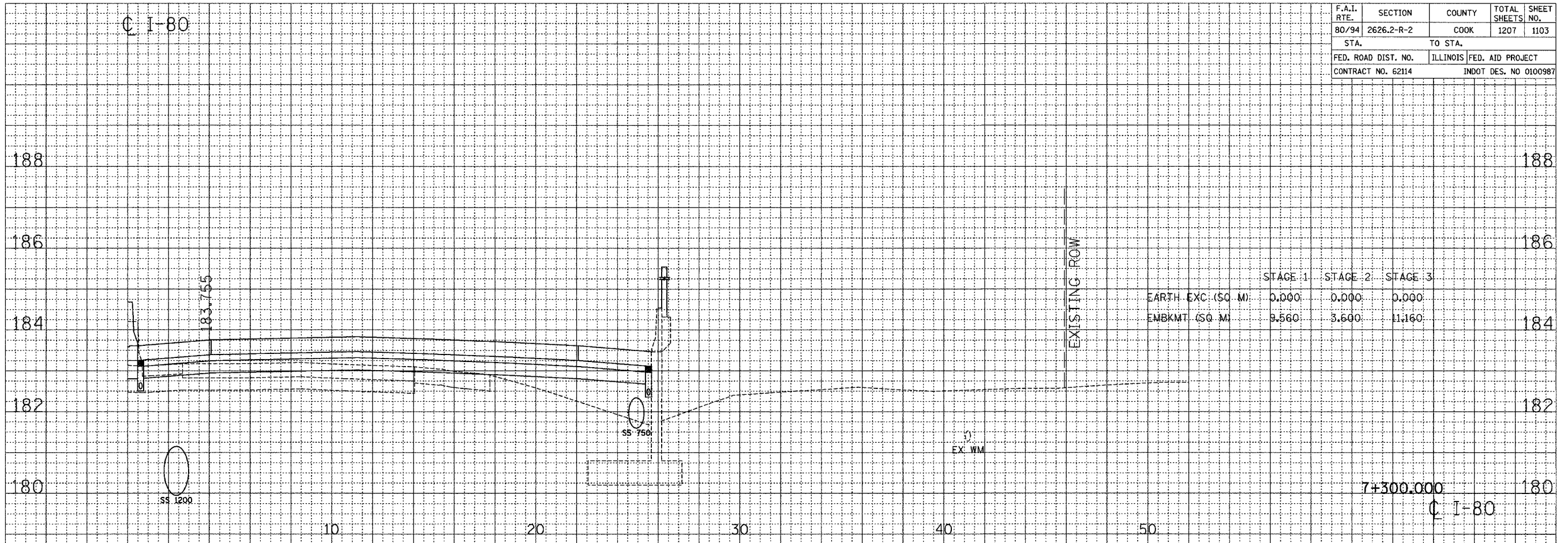

DATE	
BY	
ORIGINAL SURVEY	
PLOTTED	
NOTE BOOK	
AREAS	
AREAS CHECKED	

DATE	
BY	
ORIGINAL SURVEY	
PLOTTED	
NOTE BOOK	
AREAS	
AREAS CHECKED	

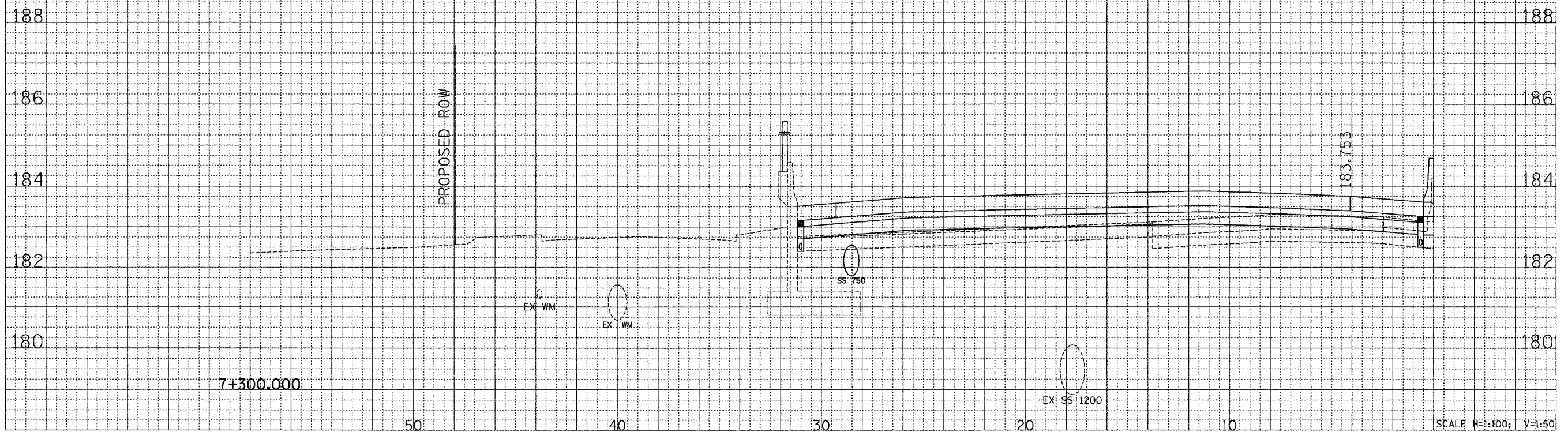

CROSS SECTION - I-80/94/US 6

F.A.I. RTE.	SECTION	COUNTY	TOTAL SHEETS	SHEET NO.
80/94	2626.2-R-2	COOK	1207	1104
STA.		TO STA.		
FED. ROAD DIST. NO.		ILLINOIS FED. AID PROJECT		
CONTRACT NO. 62114		INDOT DES. NO 0100987		

BY	DATE
ORIGINAL SURVEY	DATE
NO. BOOK	NO.
AREAS CHECKED	

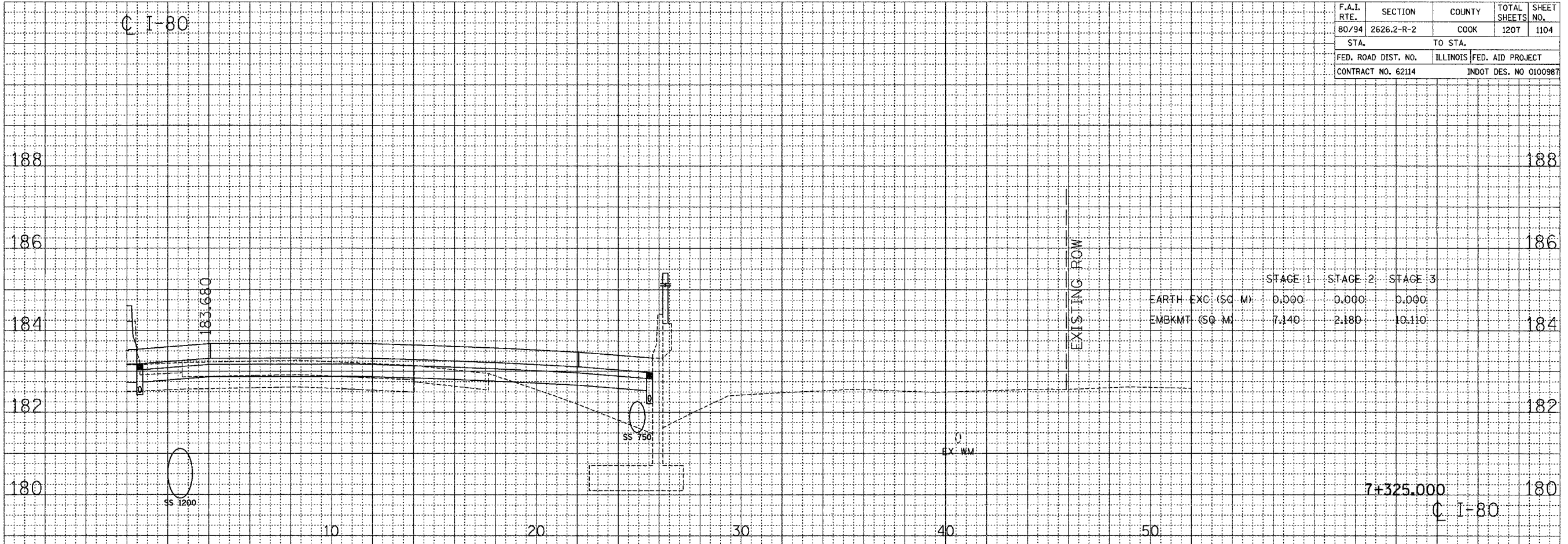

BY	DATE
ORIGINAL SURVEY	DATE
NO. BOOK	NO.
AREAS CHECKED	

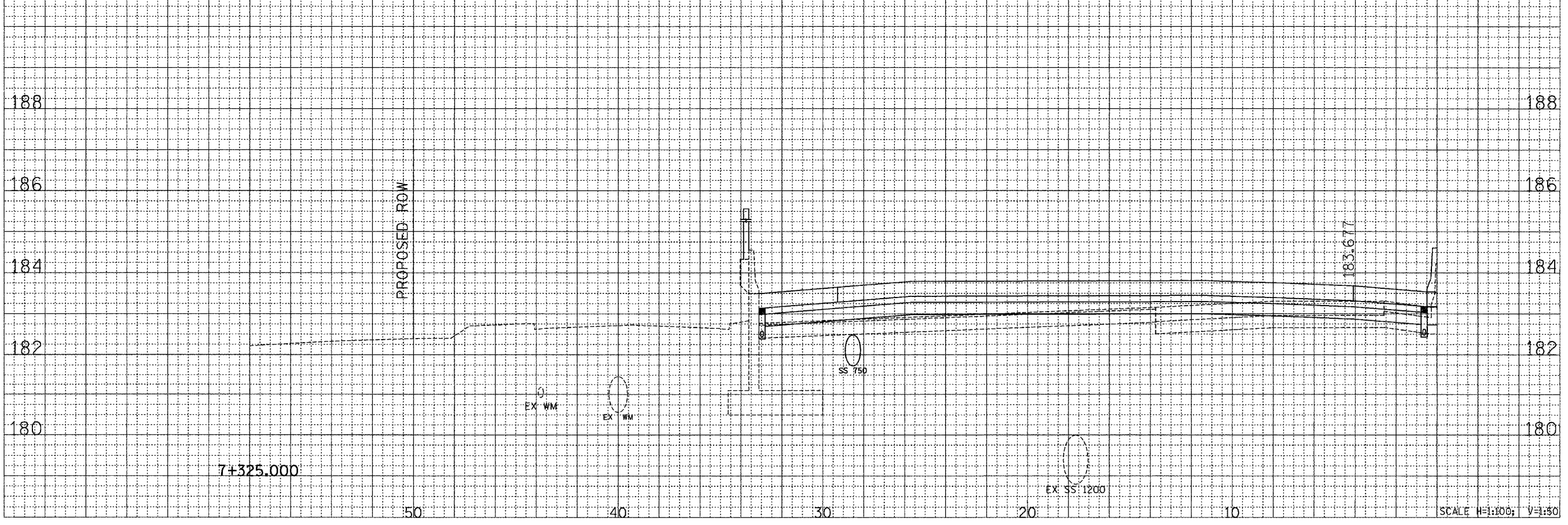

CROSS SECTION - I-80/94/US 6

SCALE H=1:100; V=1:50

F.A.I. RTE.	SECTION	COUNTY	TOTAL SHEETS	SHEET NO.
80/94	2626.2-R-2	COOK	1207	1105
STA.		TO STA.		
FED. ROAD DIST. NO.		ILLINOIS FED. AID PROJECT		
CONTRACT NO. 62114		INDOT DES. NO 0100987		

FINAL SURVEY	DATE
SURVEYED	
PLOTTED	
NOTE BOOK	
AREAS	
CHECKED	
NO.	

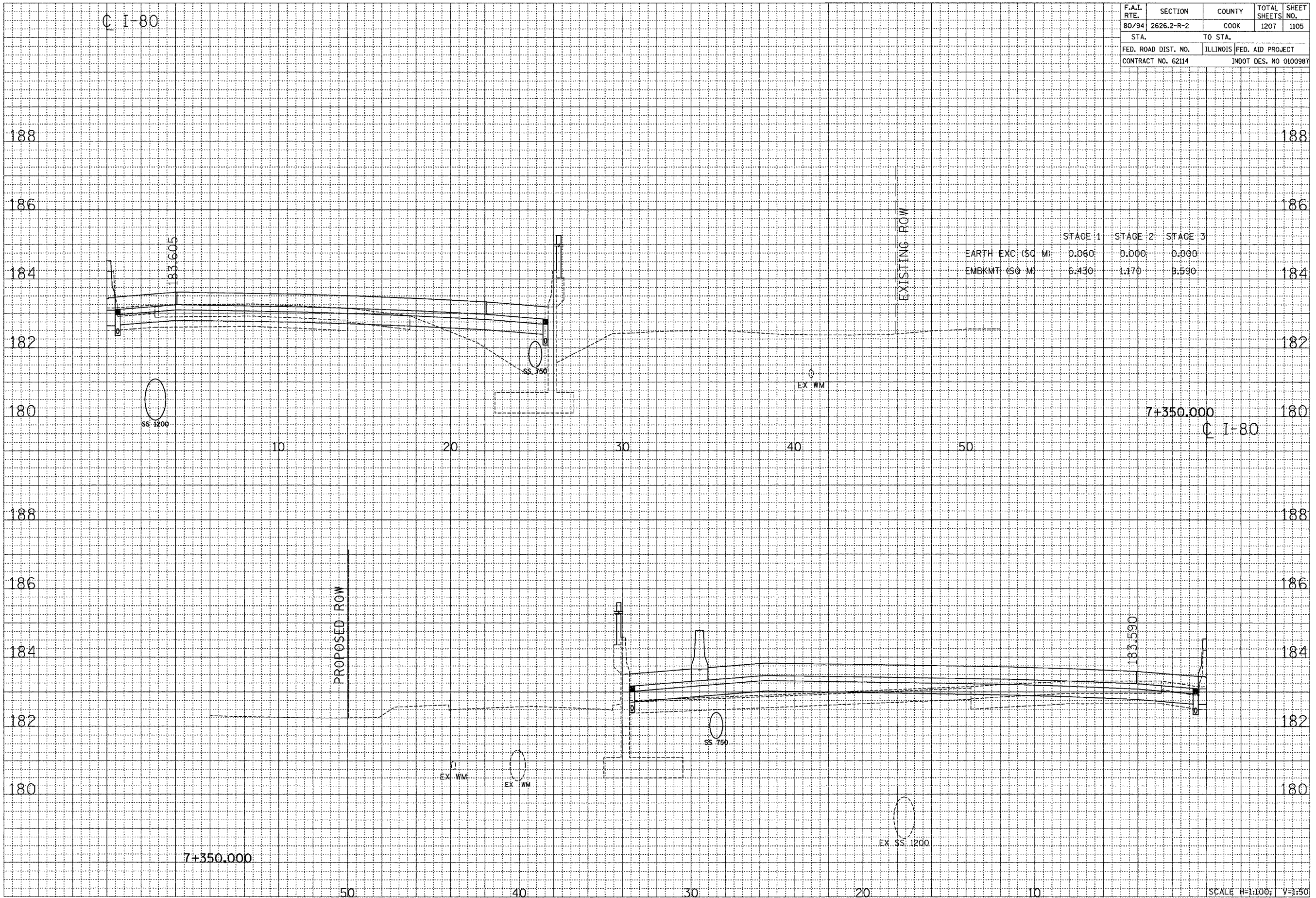

	STAGE 1	STAGE 2	STAGE 3
EARTH EXC (SQ M)	0.060	0.000	0.000
EMBKMT (SQ M)	6.430	1.170	9.590

ORIGINAL SURVEY	DATE
SURVEYED	
PLOTTED	
NOTE BOOK	
AREAS	
CHECKED	
NO.	

CROSS SECTION - I-80/94/US 6

SCALE H=1:100; V=1:50

C I-80

F.A.I. RTE.	SECTION	COUNTY	TOTAL SHEETS	SHEET NO.
80/94	2626.2-R-2	COOK	1207	1106
STA.		TO STA.		
FED. ROAD DIST. NO.		ILLINOIS	FED. AID PROJECT	
CONTRACT NO. 62114		INDOT DES. NO 0100987		

FINAL SURVEY	DATE
SURVEYED	BY
NOTE BOOK	
NO.	
AREAS CHECKED	

ORIGINAL SURVEY	DATE
SURVEYED	BY
NOTE BOOK	
NO.	
AREAS CHECKED	

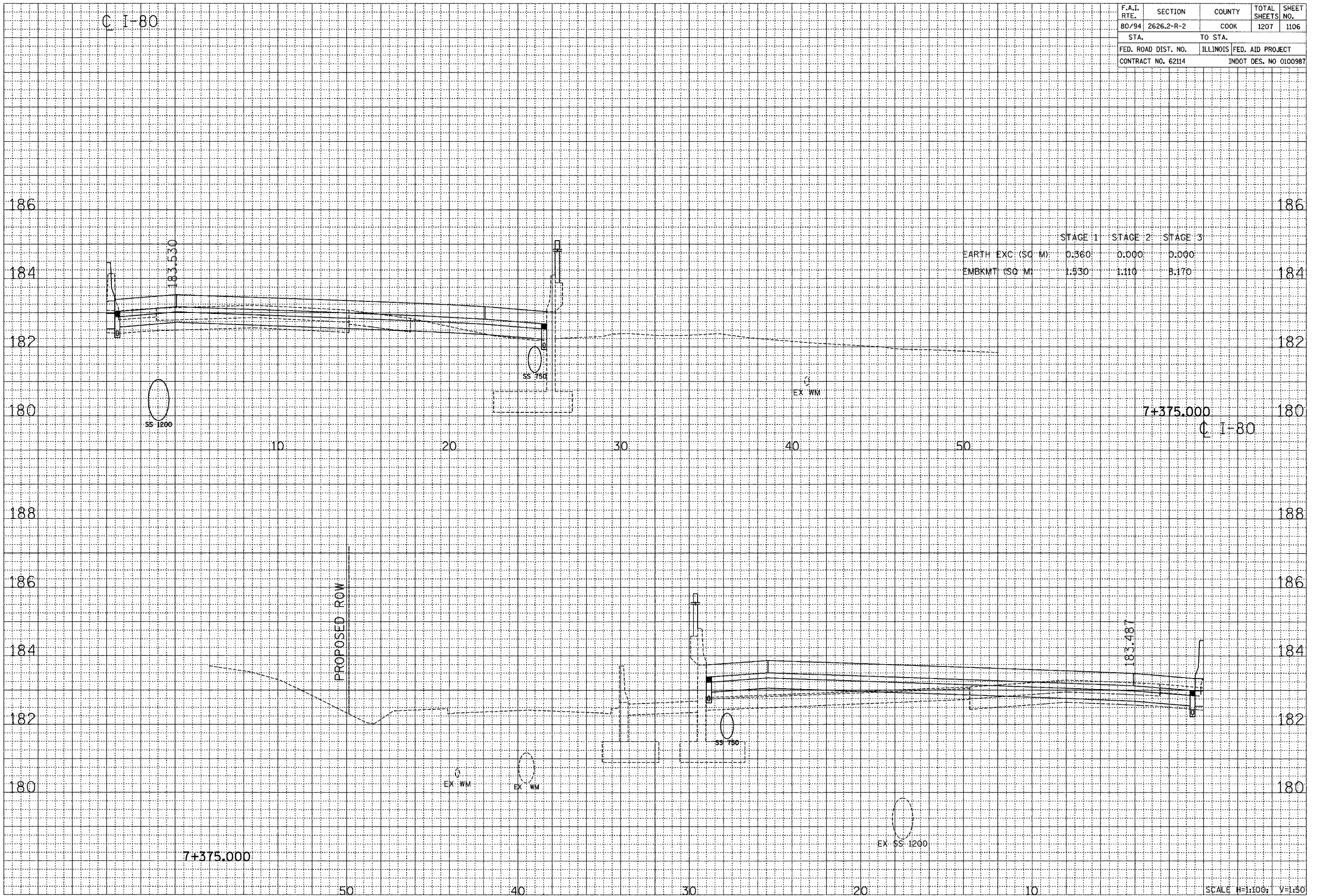

...\\pwr614\us0014.rds 06/15/2005 09:45:34 AM

C I-80

F.A.I. RTE.	SECTION	COUNTY	TOTAL SHEETS	SHEET NO.
80/94	2626.2-R-2	COOK	1207	1107
STA.		TO STA.		
FED. ROAD DIST. NO.		ILLINOIS FED. AID PROJECT		
CONTRACT NO. 62114		INDOT DES. NO 0100987		

BY	DATE
ORIGINAL SURVEY	DATE
PLOTTED	DATE
NOTE BOOK	NO.
AREAS CHECKED	

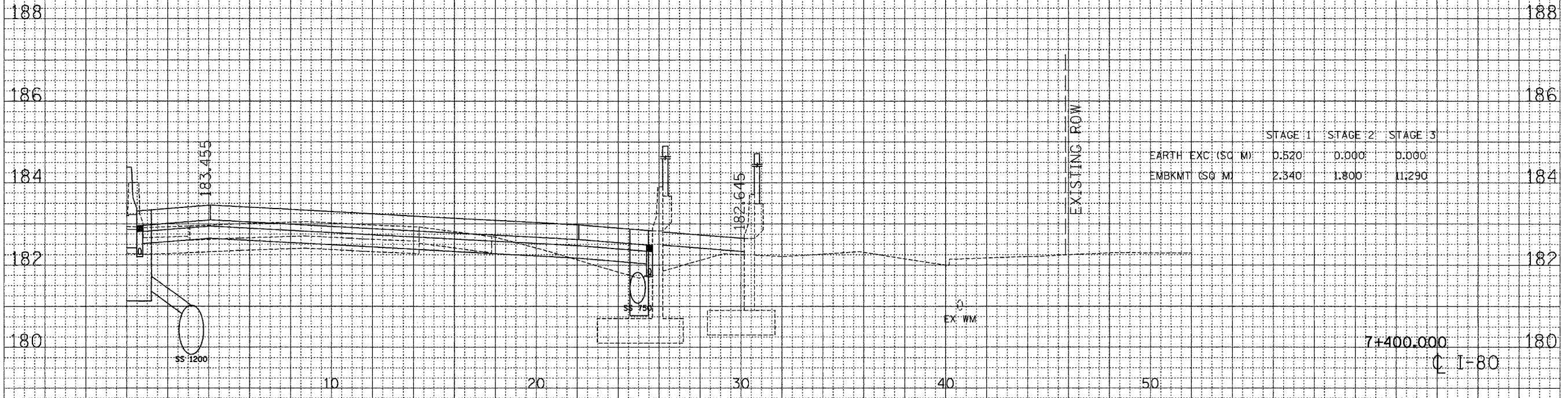

	STAGE 1	STAGE 2	STAGE 3
EARTH EXC (SQ M)	0.520	0.000	0.000
EMBKMT (SQ M)	2.340	1.800	11.290

BY	DATE
ORIGINAL SURVEY	DATE
PLOTTED	DATE
NOTE BOOK	NO.
AREAS CHECKED	

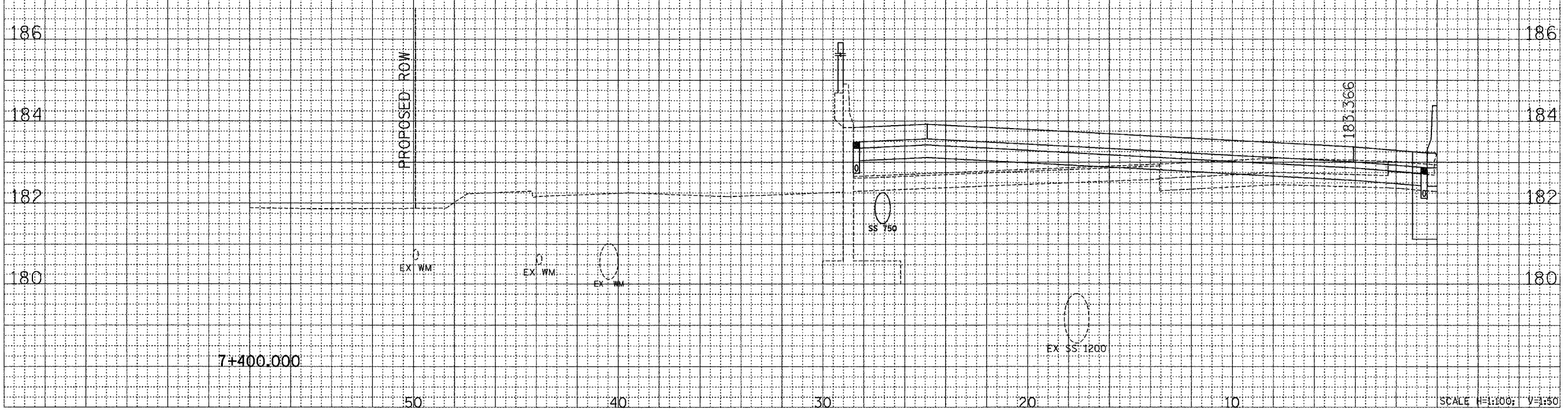

CROSS SECTION - I-80/94/US 6

Scale: H=1:100; V=1:50

F.A.I. RTE.	SECTION	COUNTY	TOTAL SHEETS	SHEET NO.
80/94	2626.2-R-2	COOK	1207	1108
STA.		TO STA.		
FED. ROAD DIST. NO.		ILLINOIS FED. AID PROJECT		
CONTRACT NO. 62114		INDOT DES. NO 0100987		

DATE	BY

DATE	BY

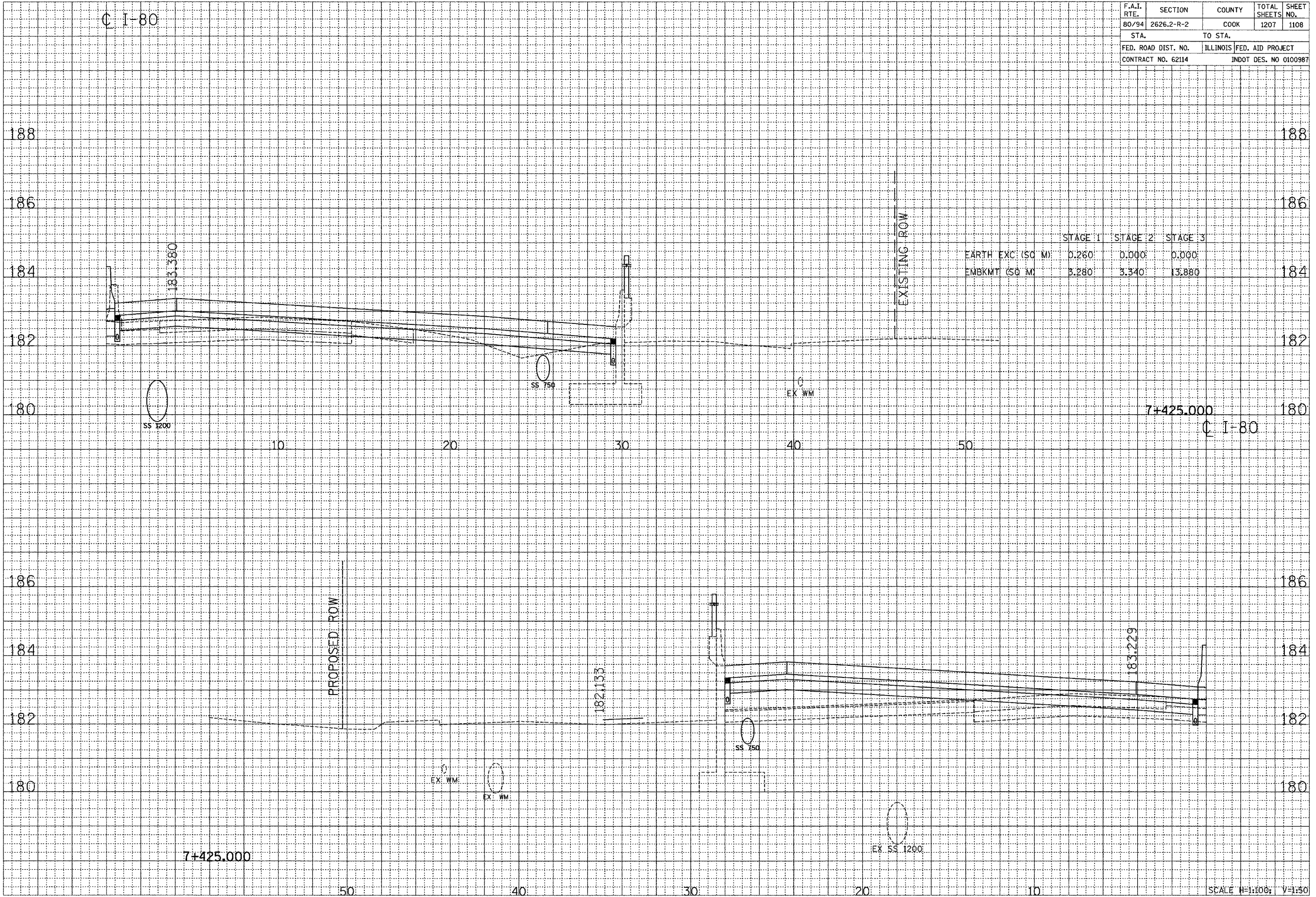

CROSS SECTION - I-80/94/US 6

\\pdr014\1\8091a.rds 02/12/2005 09:46:38 AM

F.A.I. RTE.	SECTION	COUNTY	TOTAL SHEETS	SHEET NO.
80/94	2626.2-R-2	COOK	1207	1109
STA.		TO STA.		
FED. ROAD DIST. NO.		ILLINOIS FED. AID PROJECT		
CONTRACT NO. 62114		INDOT DES. NO 0100987		

FINAL SURVEY	DATE
SAVED	
PLOTTED	
NOTE BOOK	
AREAS CHECKED	

ORIGINAL SURVEY	DATE
SAVED	
PLOTTED	
NOTE BOOK	
AREAS CHECKED	

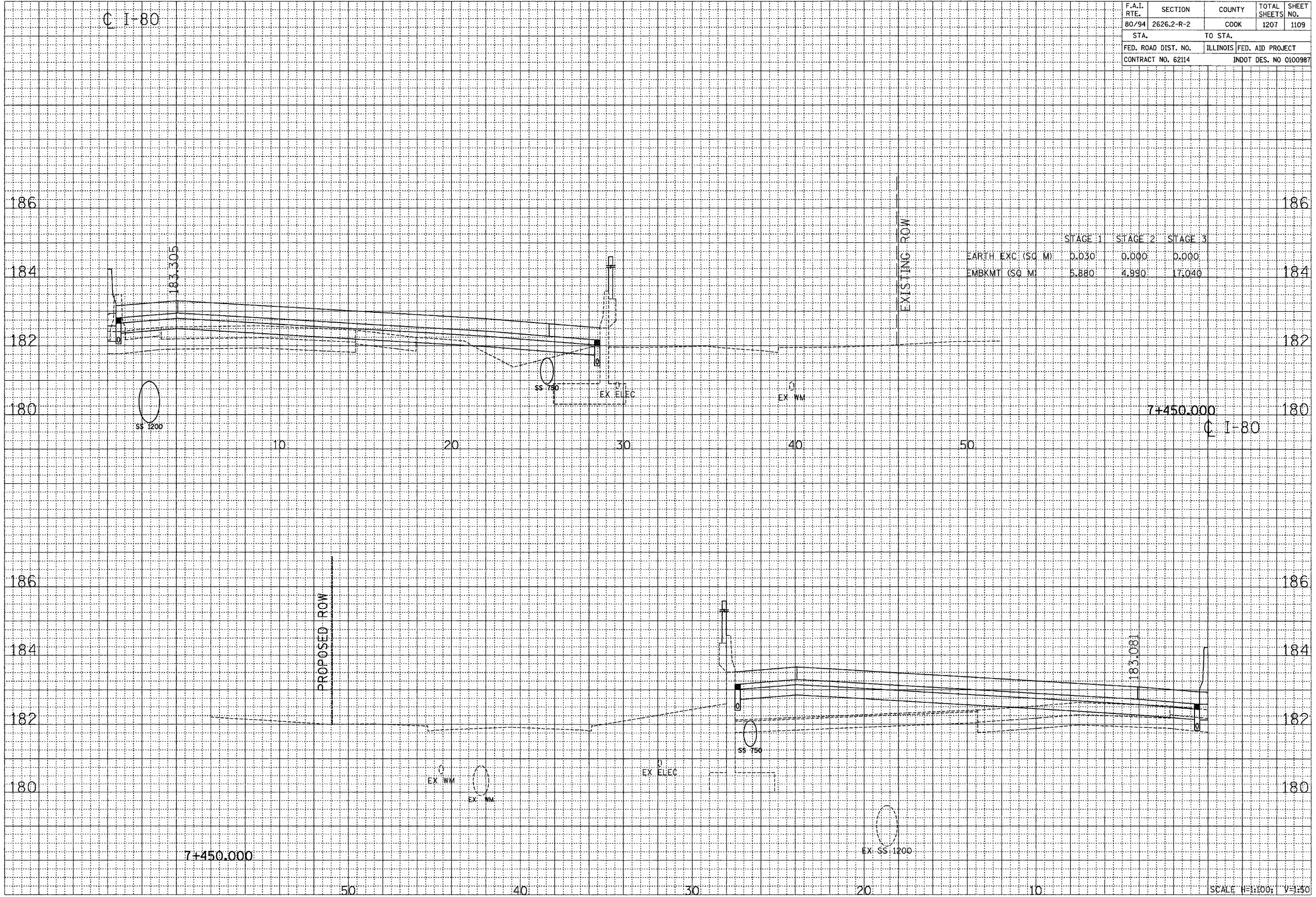

CROSS SECTION - I-80/94/US 6

F.A.I. RTE.	SECTION	COUNTY	TOTAL SHEETS	SHEET NO.
80/94	2626.2-R-2	COOK	1207	1110
STA.		TO STA.		
FED. ROAD DIST. NO.	ILLINOIS	FED. AID PROJECT		
CONTRACT NO. 62114	INDOT DES. NO 0100987			

FINAL SURVEY	DATE
SURVEYED	
NOTE BOOK	
NO.	
AREAS CHECKED	

ORIGINAL SURVEY	DATE
SURVEYED	
NOTE BOOK	
NO.	
AREAS CHECKED	

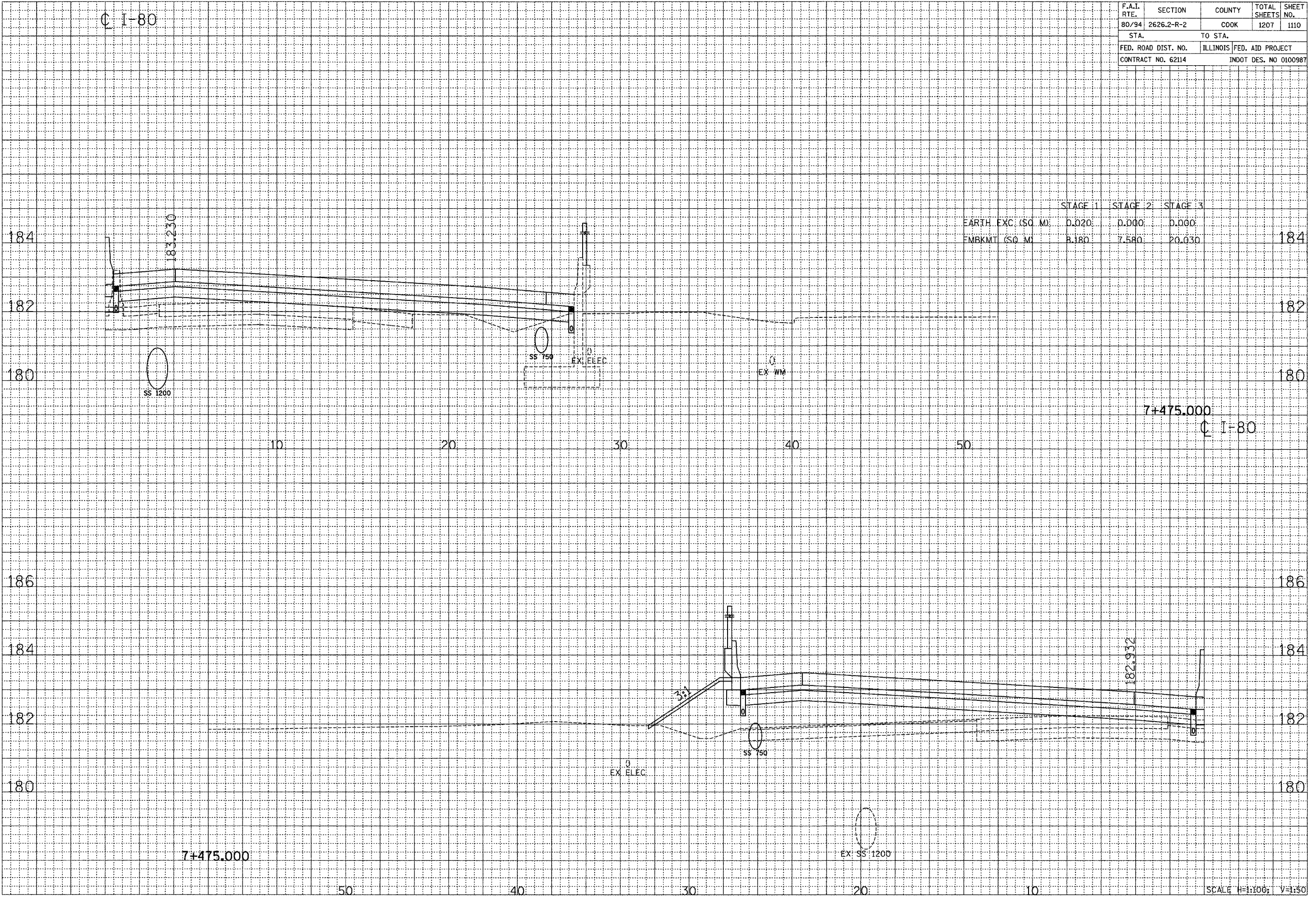

	STAGE 1	STAGE 2	STAGE 3	
EARTH EXC. (SQ. M)	0.020	0.000	0.000	184
EMBKMT (SQ. M)	8.180	7.580	20.030	184

SCALE H=1:100; V=1:50

CROSS SECTION - I-80/94/US 6

F.A.I. RTE.	SECTION	COUNTY	TOTAL SHEETS	SHEET NO.
80/94	2626.2-R-2	COOK	1207	1111
STA.		TO STA.		
FED. ROAD DIST. NO.		ILLINOIS	FED. AID PROJECT	
CONTRACT NO. 62114		INDOT DES. NO 0100987		

FINAL	DATE
SURVEY	BY
NOTE BOOK	
NO.	

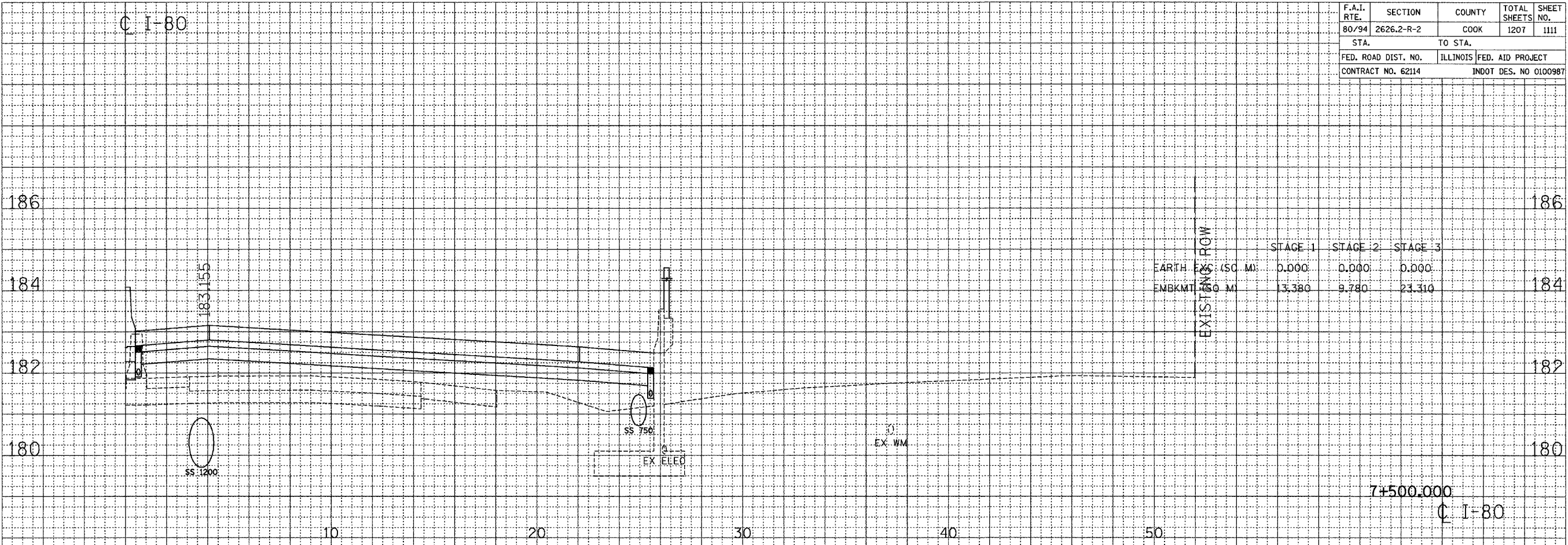

	STAGE 1	STAGE 2	STAGE 3
EARTH (SQ. M)	0.000	0.000	0.000
EMBKMT (SQ. M)	13.380	9.780	23.310

ORIGINAL	DATE
SURVEY	BY
NOTE BOOK	
NO.	

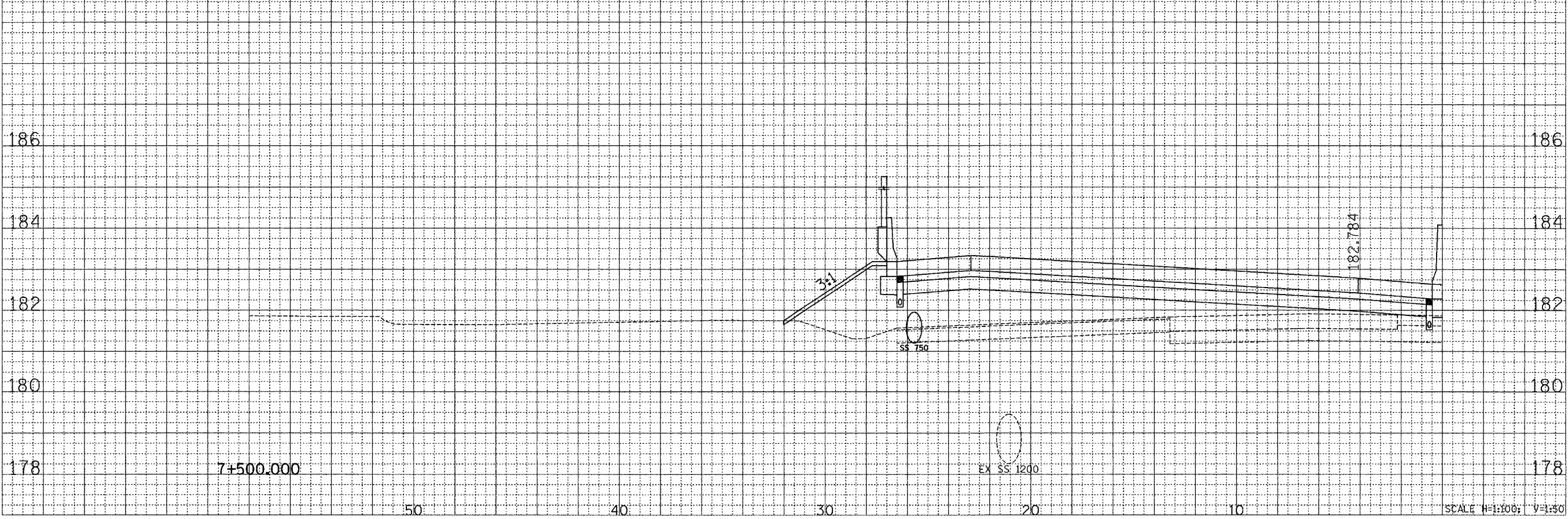

SCALE H=1:100; V=1:50

CROSS SECTION - I-80/94/US 6

...:\S:\845\8450018.rws 08/11/2005 11:47:27 AM

F.A.I. RTE.	SECTION	COUNTY	TOTAL SHEETS	SHEET NO.
80/94	2626.2-R-2	COOK	1207	1112
STA.		TO STA.		
FED. ROAD DIST. NO.		ILLINOIS FED. AID PROJECT		
CONTRACT NO. 62114		INDOT DES. NO 0100987		

FINAL SURVEY	DATE
BY	
NO. _____	
AREAS CHECKED	

ORIGINAL SURVEY	DATE
BY	
NO. _____	
AREAS CHECKED	

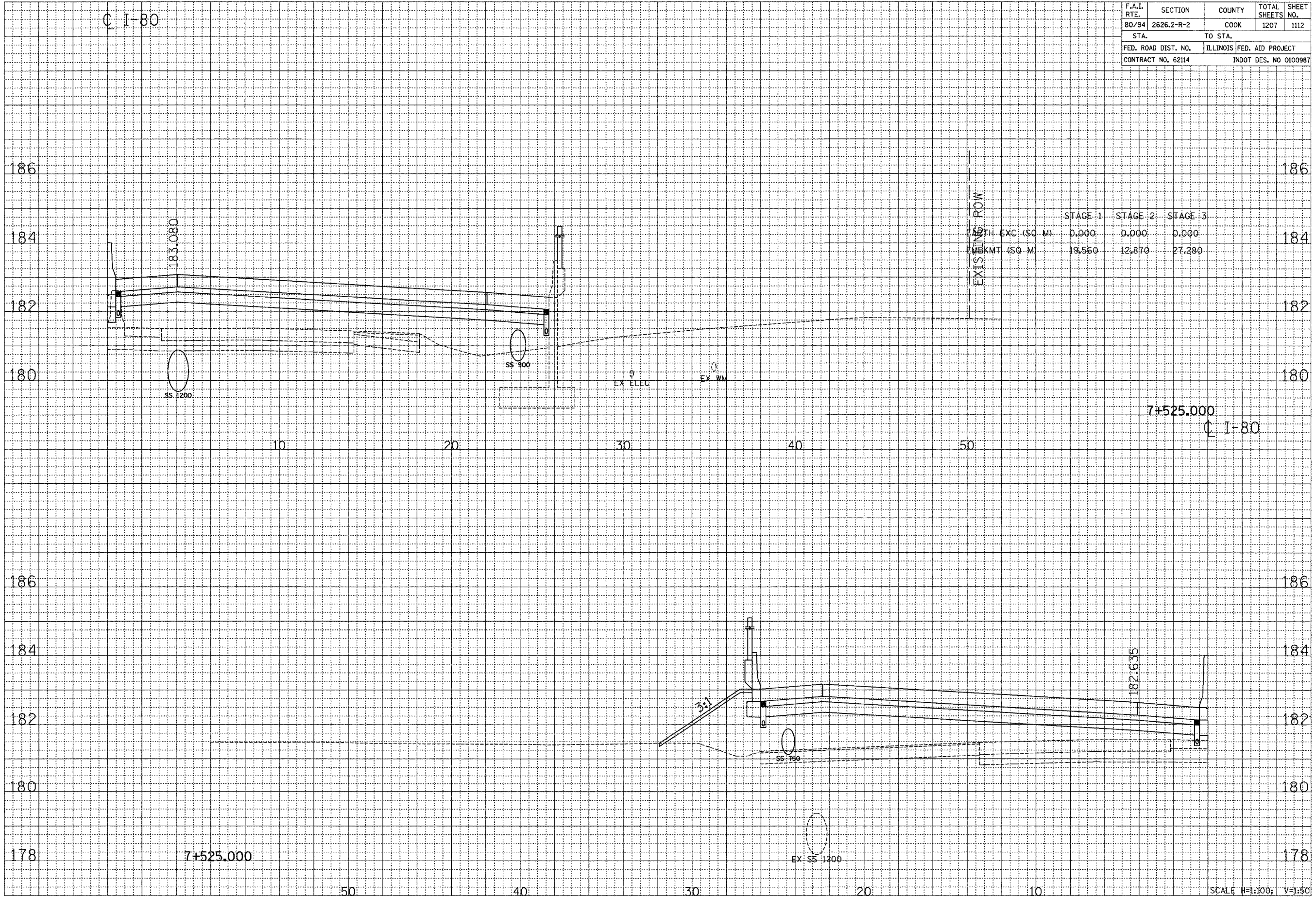

	STAGE 1	STAGE 2	STAGE 3
WIDTH EXC. (SQ. M.)	0.000	0.000	0.000
LENGTH (SQ. M.)	19.560	12.870	27.280

7+525.000
C I-80

SCALE H=1:100; V=1:50

CROSS SECTION - I-80/94/US 6

...:\Sheets\west001a.rvt 08/11/2006 11:47:27 AM

F.A.I. RTE.	SECTION	COUNTY	TOTAL SHEETS	SHEET NO.
80/94	2626.2-R-2	COOK	1207	1113
STA.		TO STA.		
FED. ROAD DIST. NO.		ILLINOIS FED. AID PROJECT		
CONTRACT NO. 62114		INDOT DES. NO 0100987		

FINAL SURVEY	DATE
SURVEYED	BY
NOTE BOOK	
NO.	
AREAS CHECKED	

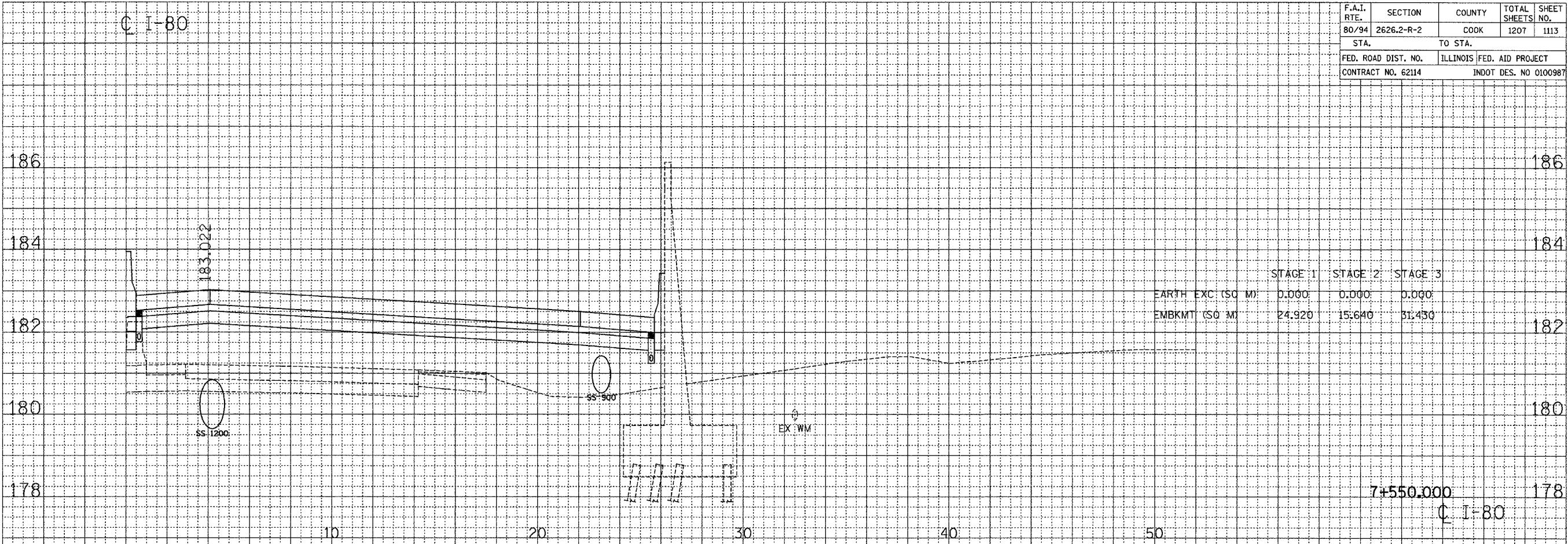

ORIGINAL SURVEY	DATE
SURVEYED	BY
NOTE BOOK	
NO.	
AREAS CHECKED	

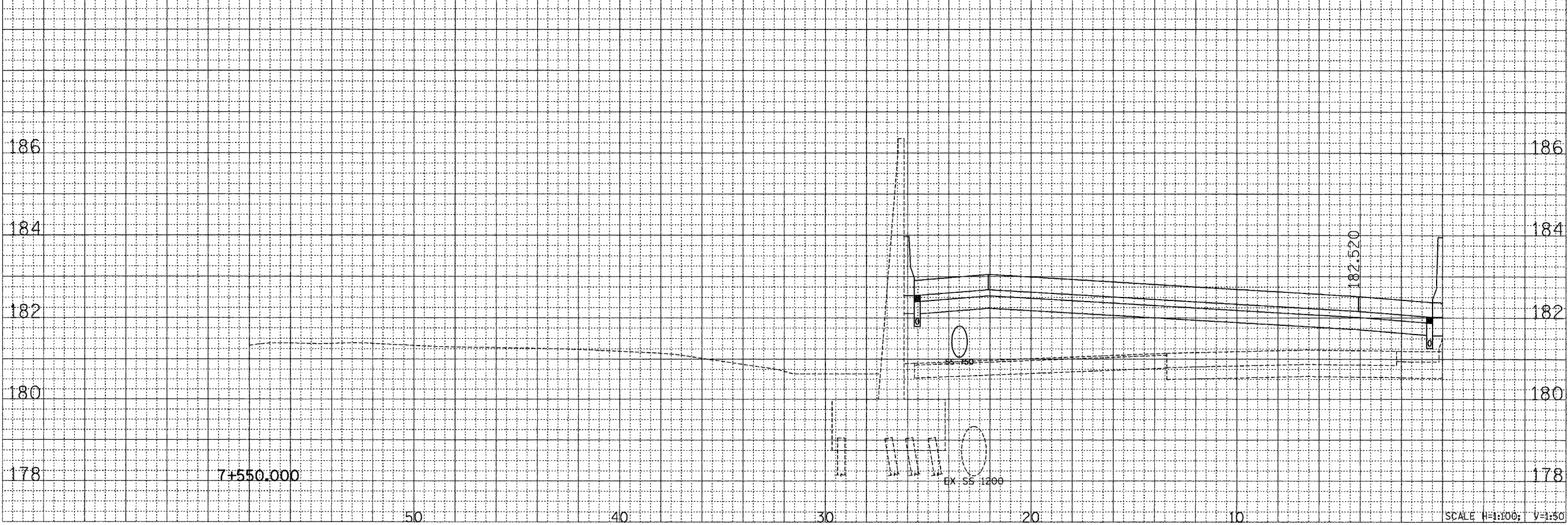

SCALE H=1:100; V=1:50

CROSS SECTION - I-80/94/US 6

\\gpcas100118.cas 06/11/2005 11:47:39 AM

F.A.I. RTE.	SECTION	COUNTY	TOTAL SHEETS	SHEET NO.
80/94	2626.2-R-2	COOK	1207	1114
STA.		TO STA.		
FED. ROAD DIST. NO.		ILLINOIS	FED. AID PROJECT	
CONTRACT NO. 62114		INDOT DES. NO 0100987		

FINAL SURVEY	BY	DATE
NO. _____	_____	_____
NO. _____	_____	_____
NO. _____	_____	_____
NO. _____	_____	_____

ORIGINAL SURVEY	BY	DATE
NO. _____	_____	_____
NO. _____	_____	_____
NO. _____	_____	_____
NO. _____	_____	_____

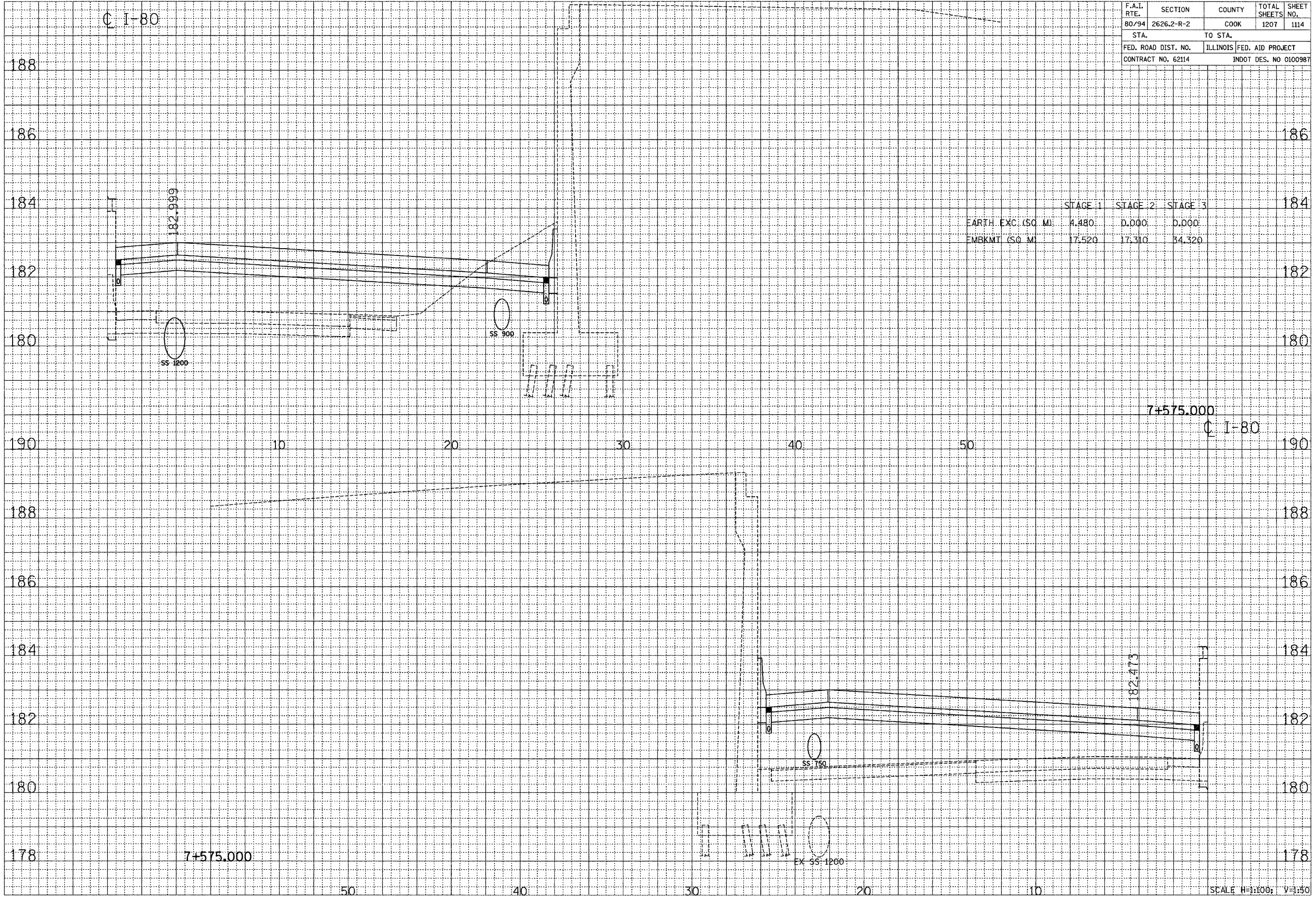

	STAGE 1	STAGE 2	STAGE 3
EARTH. EXC. (SQ. M)	4.480	0.000	0.000
EMBKMT. (SQ. M)	17.520	17.310	34.320

CROSS SECTION - I-80/94/US 6

F.A.I. RTE.	SECTION	COUNTY	TOTAL SHEETS	SHEET NO.
80/94	2626.2-R-2	COOK	1207	1115
STA.		TO STA.		
FED. ROAD DIST. NO.		ILLINOIS FED. AID PROJECT		
CONTRACT NO. 62114		INDOT DES. NO 0100987		

FINAL SURVEY	BY	DATE
NO. _____	_____	_____
SAVED	BY	DATE
NO. _____	_____	_____
PLOTTED	BY	DATE
NO. _____	_____	_____
AREAS CHECKED	BY	DATE
NO. _____	_____	_____

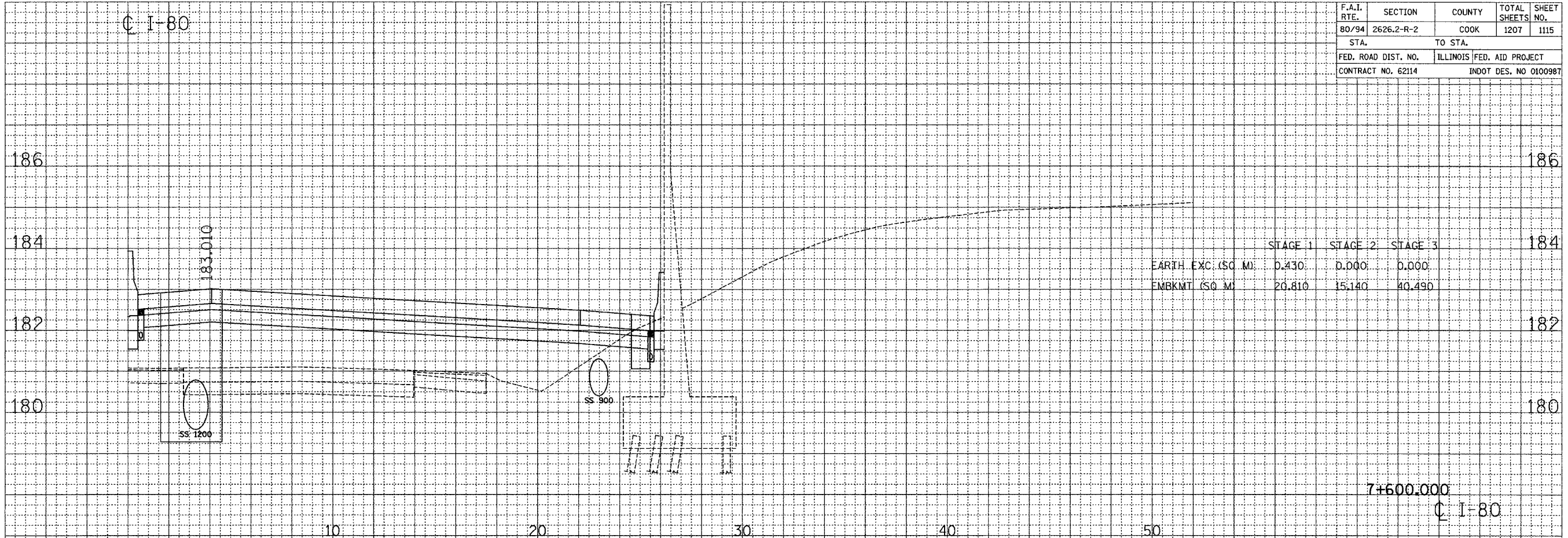

ORIGINAL SURVEY	BY	DATE
NO. _____	_____	_____
SAVED	BY	DATE
NO. _____	_____	_____
PLOTTED	BY	DATE
NO. _____	_____	_____
AREAS CHECKED	BY	DATE
NO. _____	_____	_____

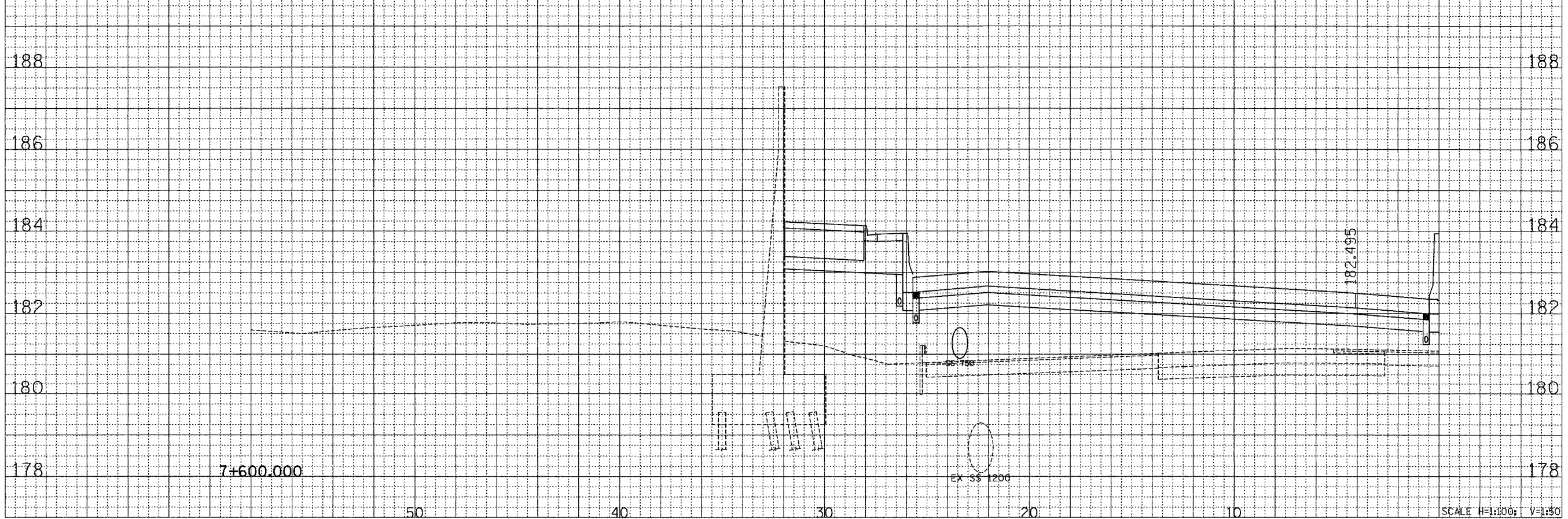

CROSS SECTION - I-80/94/US 6

...:\Spears\res\011a.rps 08/17/2005 11:47:29 AM

F.A.I. RTE.	SECTION	COUNTY	TOTAL SHEETS	SHEET NO.
80/94	2626.2-R-2	COOK	1207	1116
STA.	TO STA.			
FED. ROAD DIST. NO.	ILLINOIS	FED. AID PROJECT		
CONTRACT NO. 62114	INDOT DES. NO 0100987			

C I-80

FINAL SURVEY	DRAWN BY	DATE
NO. _____	_____	_____
ORIGINAL SURVEY	CHECKED BY	DATE
NO. _____	_____	_____
NOTE BOOK	TEMP. PLATE	AREAS CHECKED
NO. _____	_____	_____

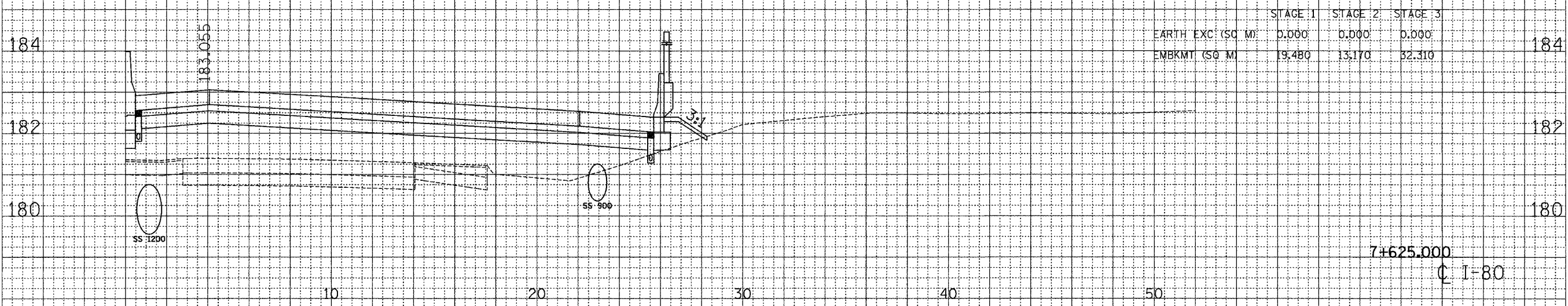

ORIGINAL SURVEY	DRAWN BY	DATE
NO. _____	_____	_____
NOTE BOOK	TEMP. PLATE	AREAS CHECKED
NO. _____	_____	_____

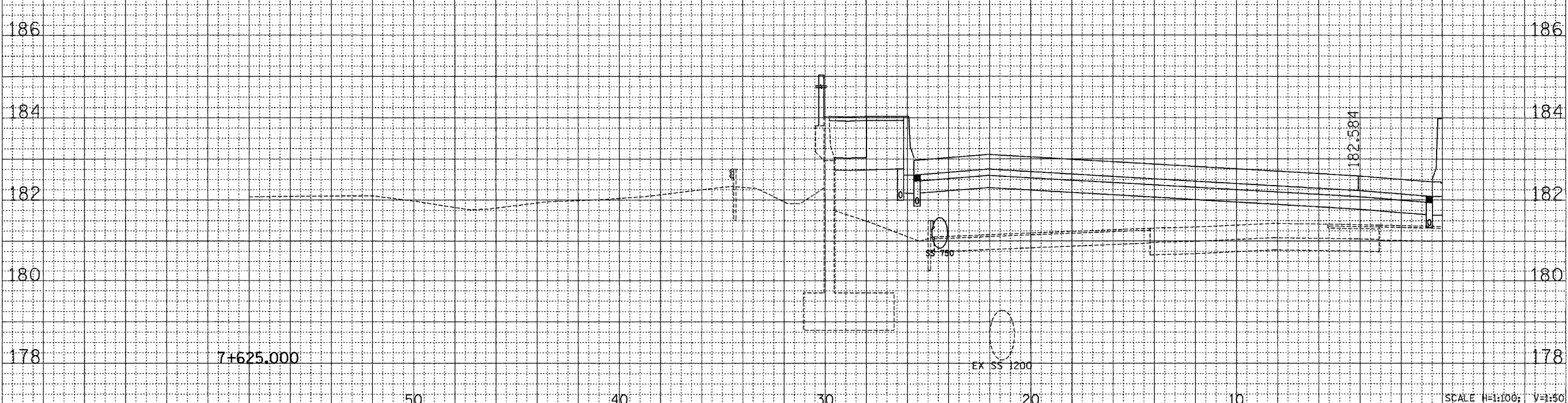

CROSS SECTION - I-80/94/US 6

F.A.I. RTE.	SECTION	COUNTY	TOTAL SHEETS	SHEET NO.
80/94	2626.2-R-2	COOK	1207	1117
STA.		TO STA.		
FED. ROAD DIST. NO.		ILLINOIS	FED. AID PROJECT	
CONTRACT NO. 62114		INDOT DES. NO. 0100987		

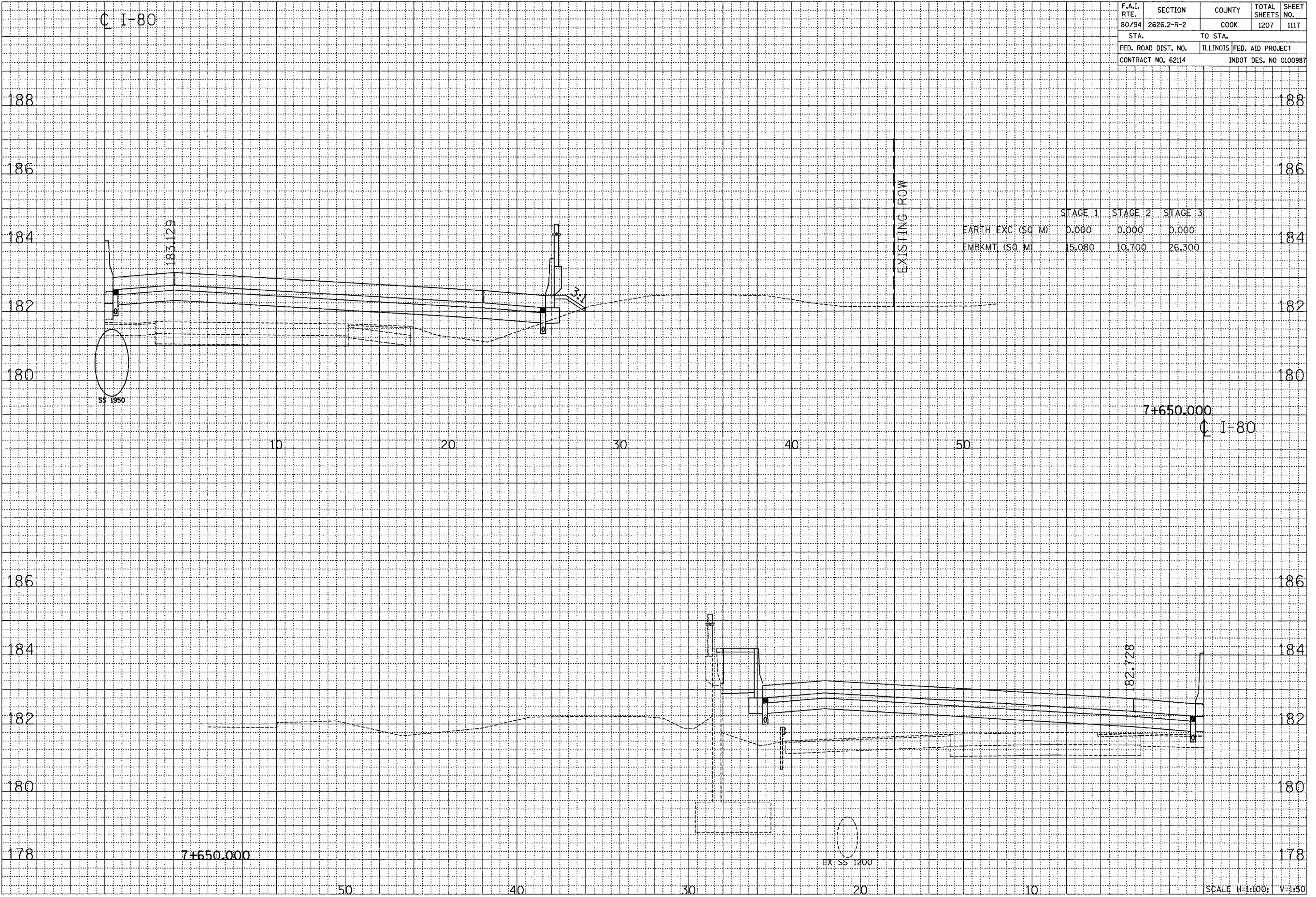

FINAL SURVEY	DATE
BY	
NO.	
AREAS CHECKED	

ORIGINAL SURVEY	DATE
BY	
NO.	
AREAS CHECKED	

CROSS SECTION - I-80/94/US 6

US-80/94/US 6 06/11/2005 11:47:30 AM

F.A.I. RTE.	SECTION	COUNTY	TOTAL SHEETS	SHEET NO.
80/94	2626.2-R-2	COOK	1207	1118
STA.		TO STA.		
FED. ROAD DIST. NO.		ILLINOIS FED. AID PROJECT		
CONTRACT NO. 62114		INDOT DES. NO 0100987		

FINAL SURVEY	BY	DATE
NO. _____	_____	_____
AREAS CHECKED	_____	_____

ORIGINAL SURVEY	BY	DATE
NO. _____	_____	_____
AREAS CHECKED	_____	_____

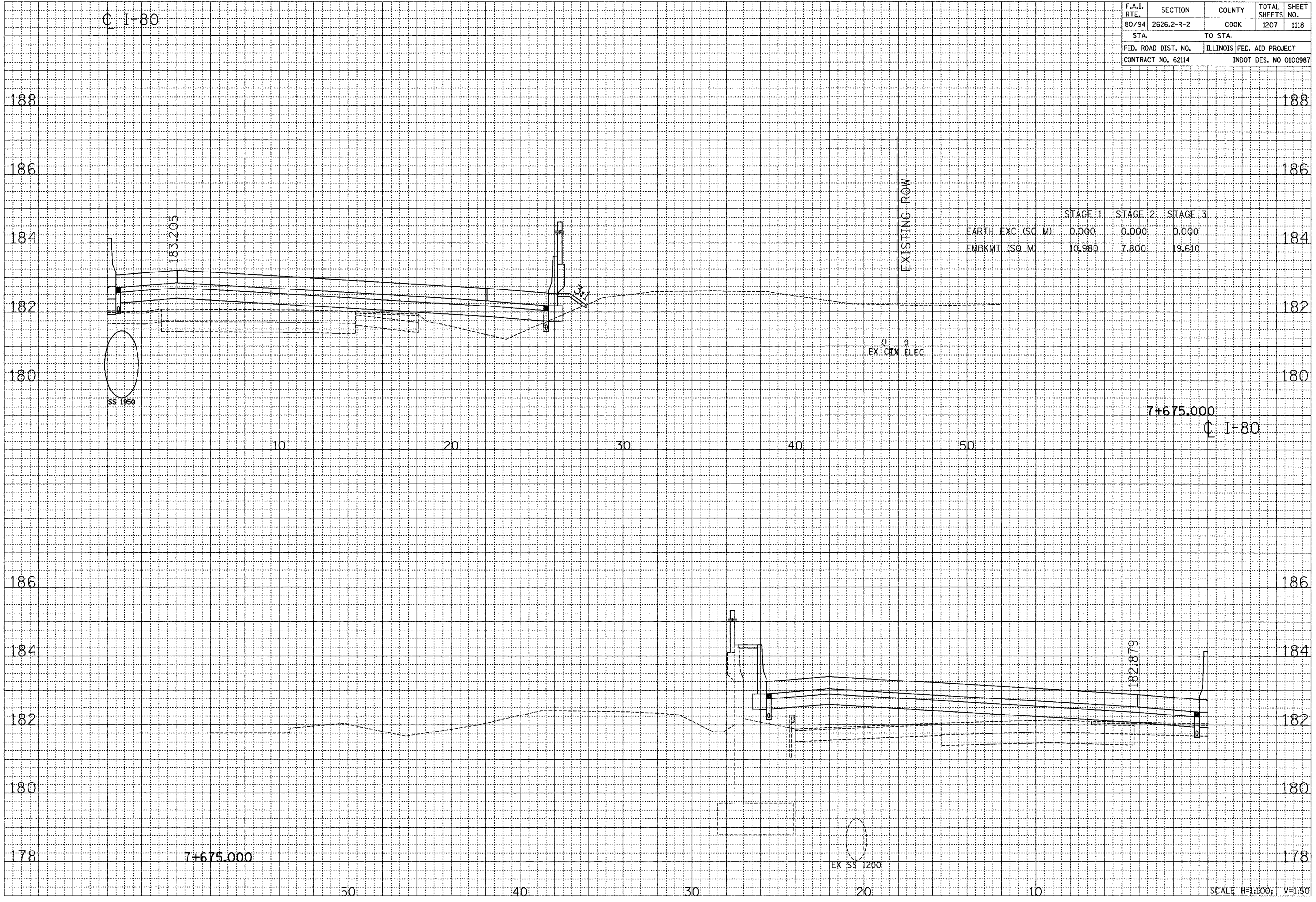

	STAGE 1	STAGE 2	STAGE 3
EARTH EXC. (SQ. M)	0.000	0.000	0.000
EMBKMT. (SQ. M)	10.980	7.800	19.630

CROSS SECTION - I-80/94/US 6

...:\p\112005\1147_21.dwg 08/17/2005 11:47:21 AM

F.A.I. RTE.	SECTION	COUNTY	TOTAL SHEETS	SHEET NO.
80/94	2626.2-R-2	COOK	1207	1119
STA.		TO STA.		
FED. ROAD DIST. NO.		ILLINOIS FED. AID PROJECT		
CONTRACT NO. 62114		INDOT DES. NO 0100987		

FINAL SURVEY	SURVEYED	DATE
NOTE BOOK NO.	PLOTTED	BY
AREAS CHECKED	AREAS CHECKED	

ORIGINAL SURVEY	SURVEYED	DATE
NOTE BOOK NO.	PLOTTED	BY
AREAS CHECKED	AREAS CHECKED	

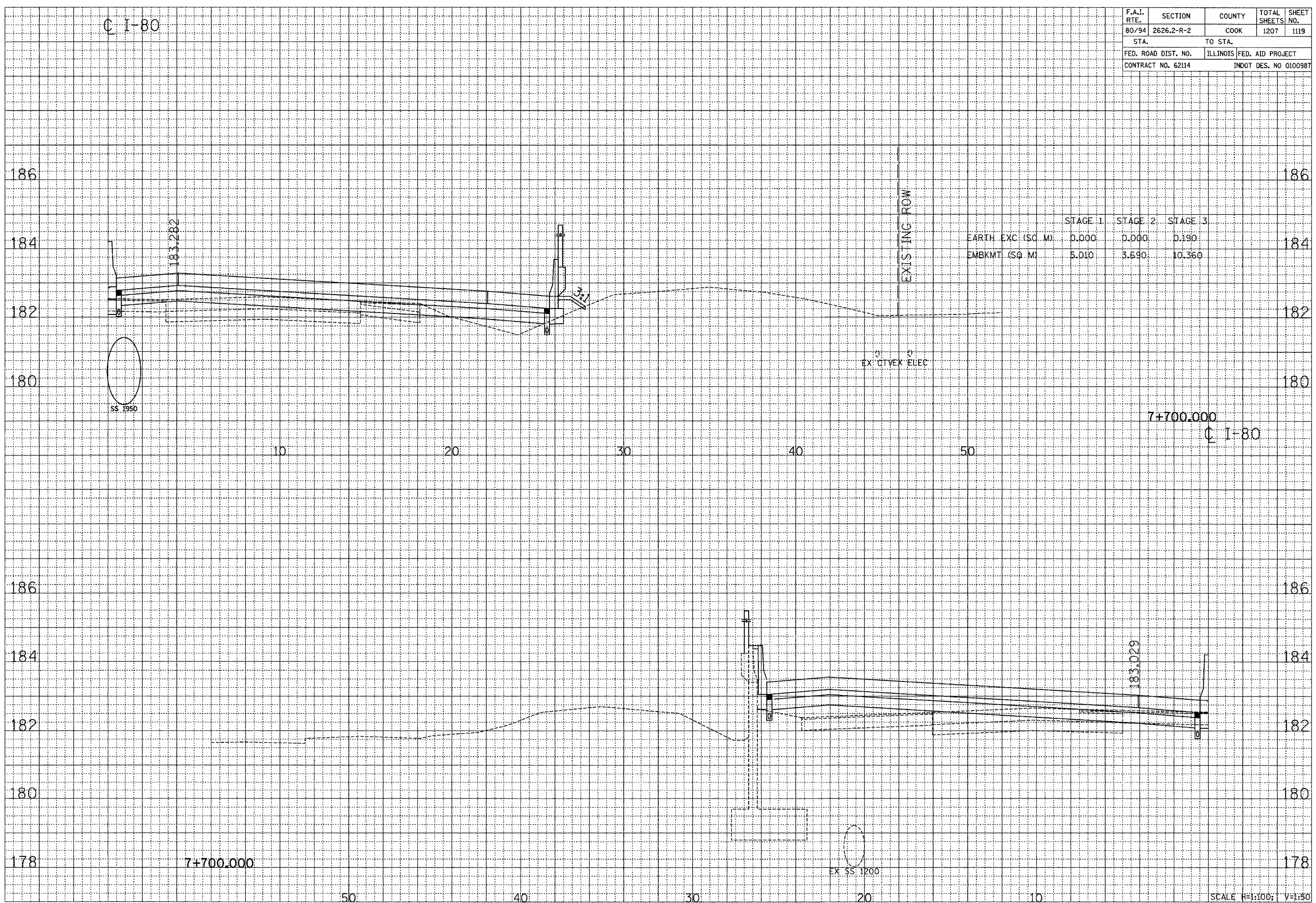

CROSS SECTION - I-80/94/US 6

...:\sharis\1001a.ms 02/11/2005 11:47:31 AM

F.A.I. RTE.	SECTION	COUNTY	TOTAL SHEETS	SHEET NO.
80/94	2626.2-R-2	COOK	1207	1120
STA.		TO STA.		
FED. ROAD DIST. NO.		ILLINOIS FED. AID PROJECT		
CONTRACT NO. 62114		INDOT DES. NO 0100987		

FINAL SURVEY	DATE
STARTED	
PLOTTED	
NOTE BOOK	
AREAS	
CHECKED	

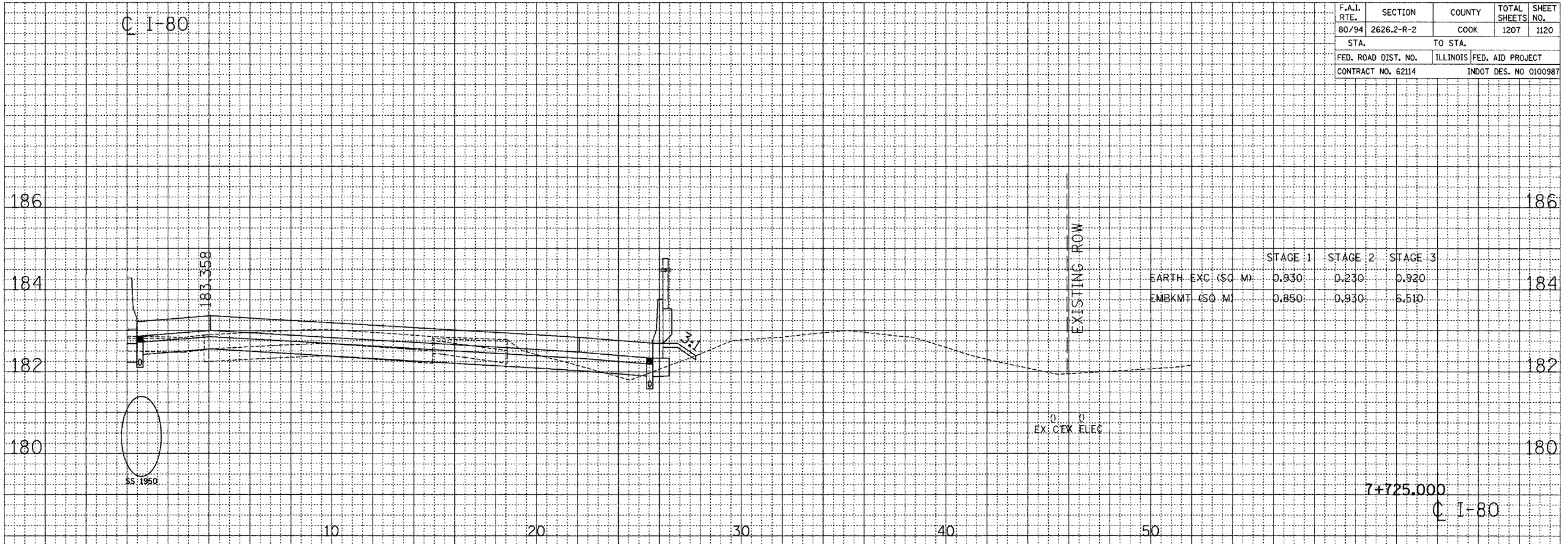

ORIGINAL SURVEY	DATE
STARTED	
PLOTTED	
NOTE BOOK	
AREAS	
CHECKED	

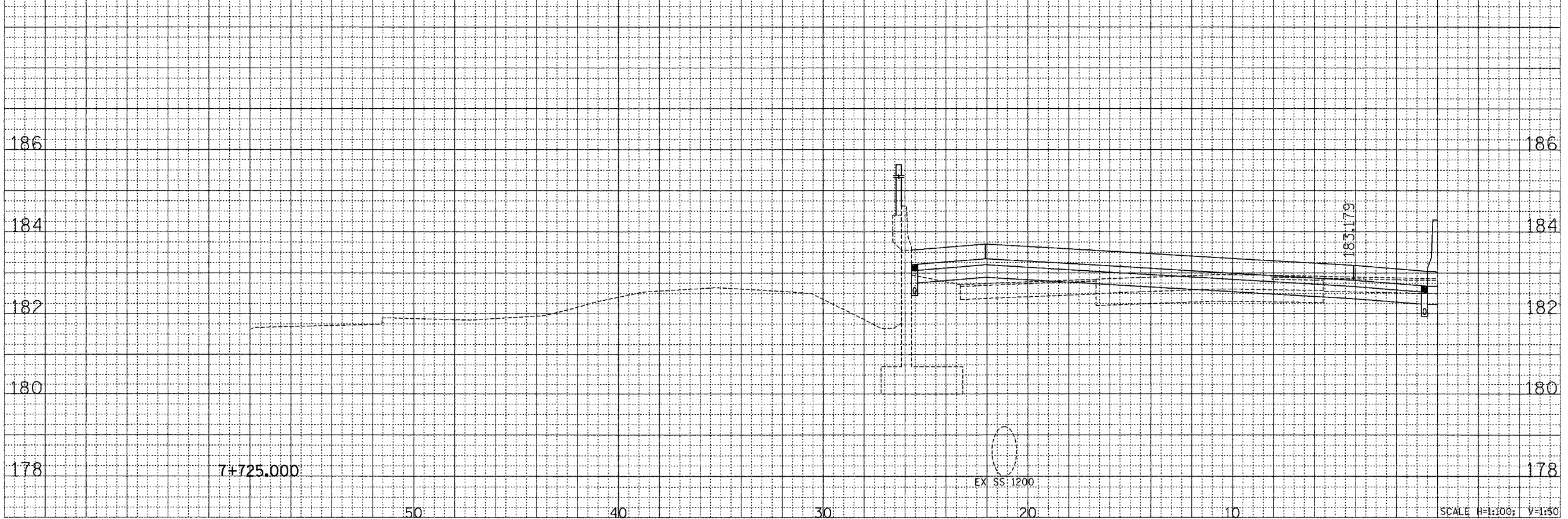

CROSS SECTION - I-80/94/US 6

Scale H=1:100; V=1:50

F.A.I. RTE.	SECTION	COUNTY	TOTAL SHEETS	SHEET NO.
80/94	2626.2-R-2	COOK	1207	1121
STA.		TO STA.		
FED. ROAD DIST. NO.		ILLINOIS	FED. AID PROJECT	
CONTRACT NO. 62114		INDOT DES. NO 0100987		

FINAL SURVEY	DATE
BY	
NO. _____	
AREAS CHECKED	

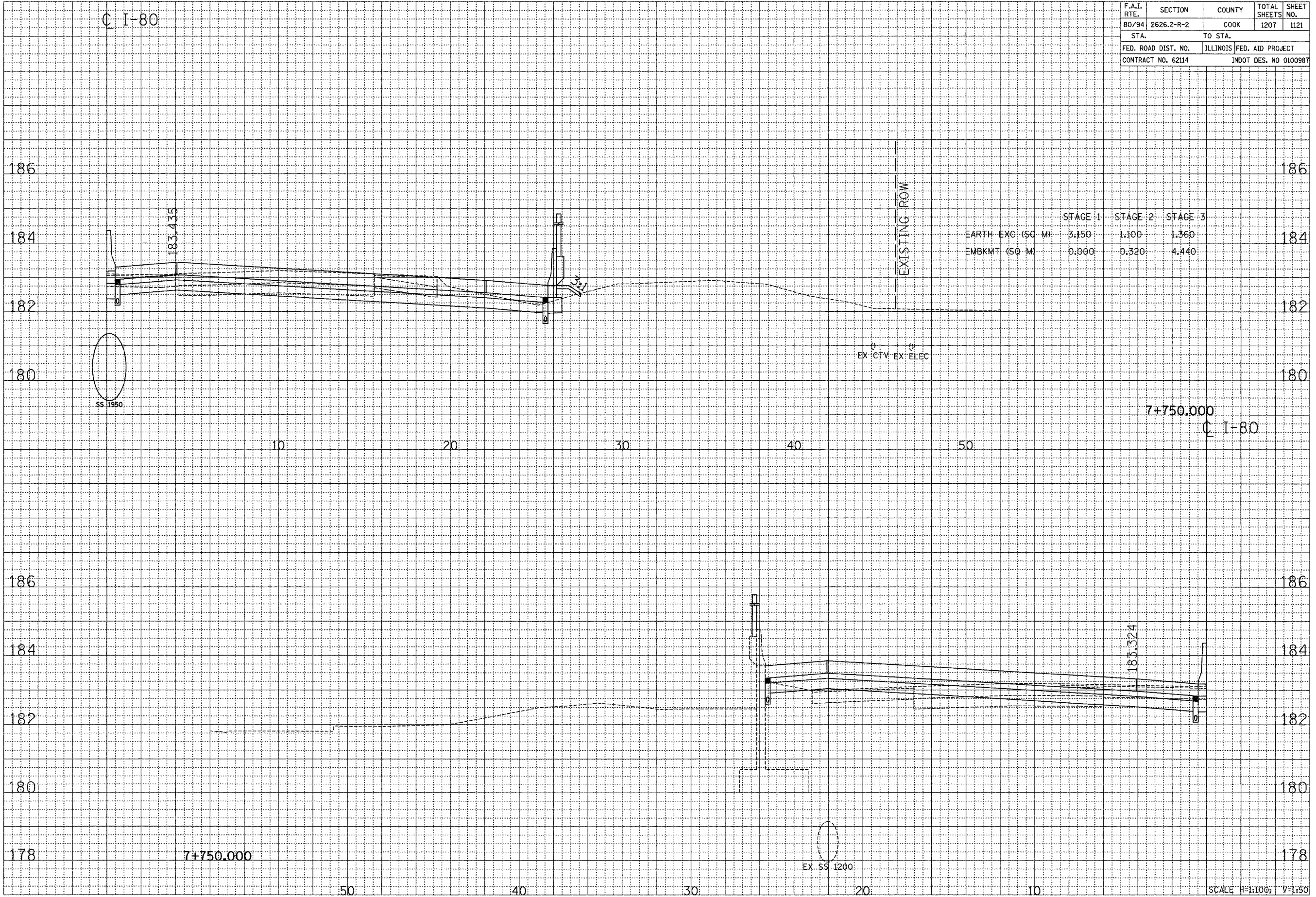

ORIGINAL SURVEY	DATE
BY	
NO. _____	
AREAS CHECKED	

CROSS SECTION - I-80/94/US 6

...:\projects\us80\11a.mxd 08/12/2005 10:40:42 AM

F.A.I. RTE.	SECTION	COUNTY	TOTAL SHEETS	SHEET NO.
80/94	2626.2-R-2	COOK	1207	1122
STA.		TO STA.		
FED. ROAD DIST. NO.		ILLINOIS	FED. AID PROJECT	
CONTRACT NO. 62114		INDOT DES. NO 0100987		

BY	DATE
FINAL SURVEY	
REVIEWED	
PLOTTED	
NOTE BOOK	
AREAS	
CHECKED	
NO.	

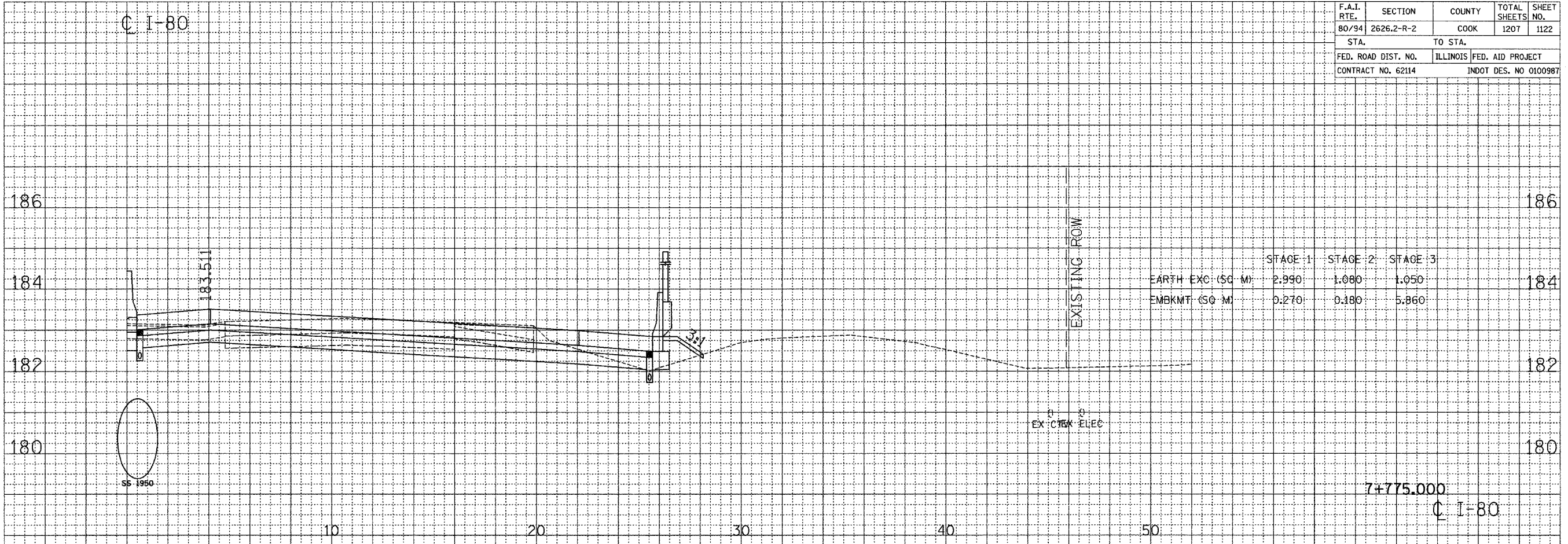

BY	DATE
ORIGINAL SURVEY	
REVIEWED	
PLOTTED	
NOTE BOOK	
AREAS	
CHECKED	
NO.	

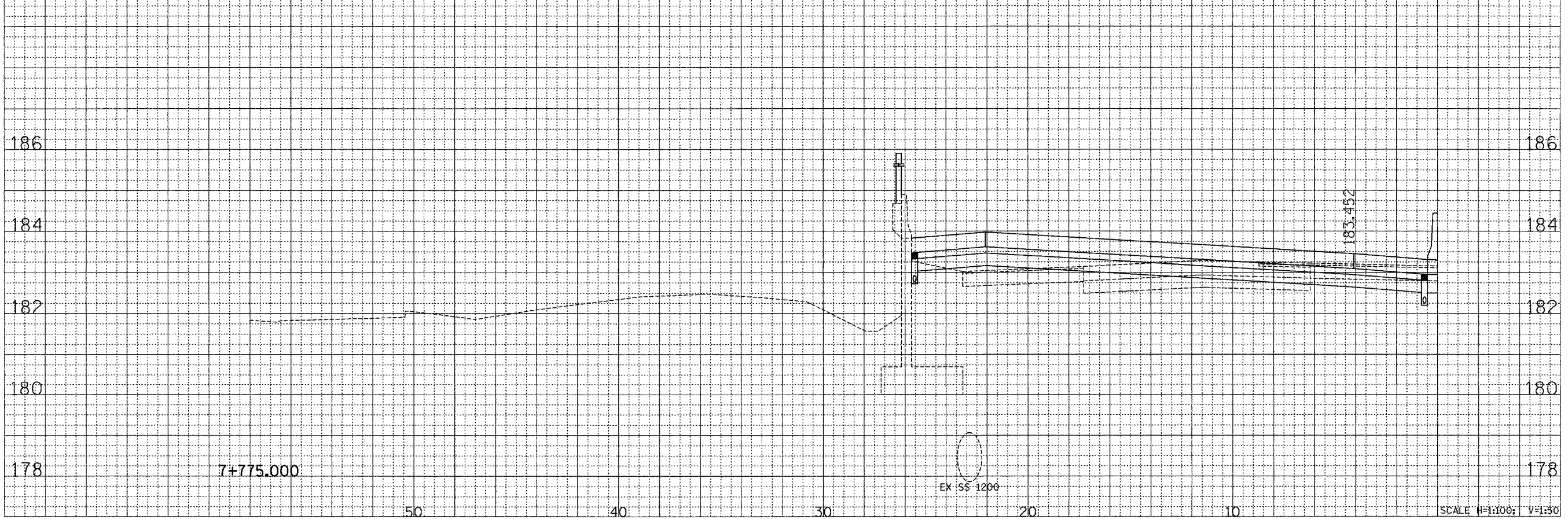

CROSS SECTION - I-80/94/US 6

...:\shers\vs160110 -sh 07/25/2005 09:47:29 AM

F.A.I. RTE.	SECTION	COUNTY	TOTAL SHEETS	SHEET NO.
80/94	2626.2-R-2	COOK	1207	1123
STA.		TO STA.		
FED. ROAD DIST. NO.		ILLINOIS FED. AID PROJECT		
CONTRACT NO. 62114		INDOT DES. NO 0100987		

DATE	BY

DATE	BY

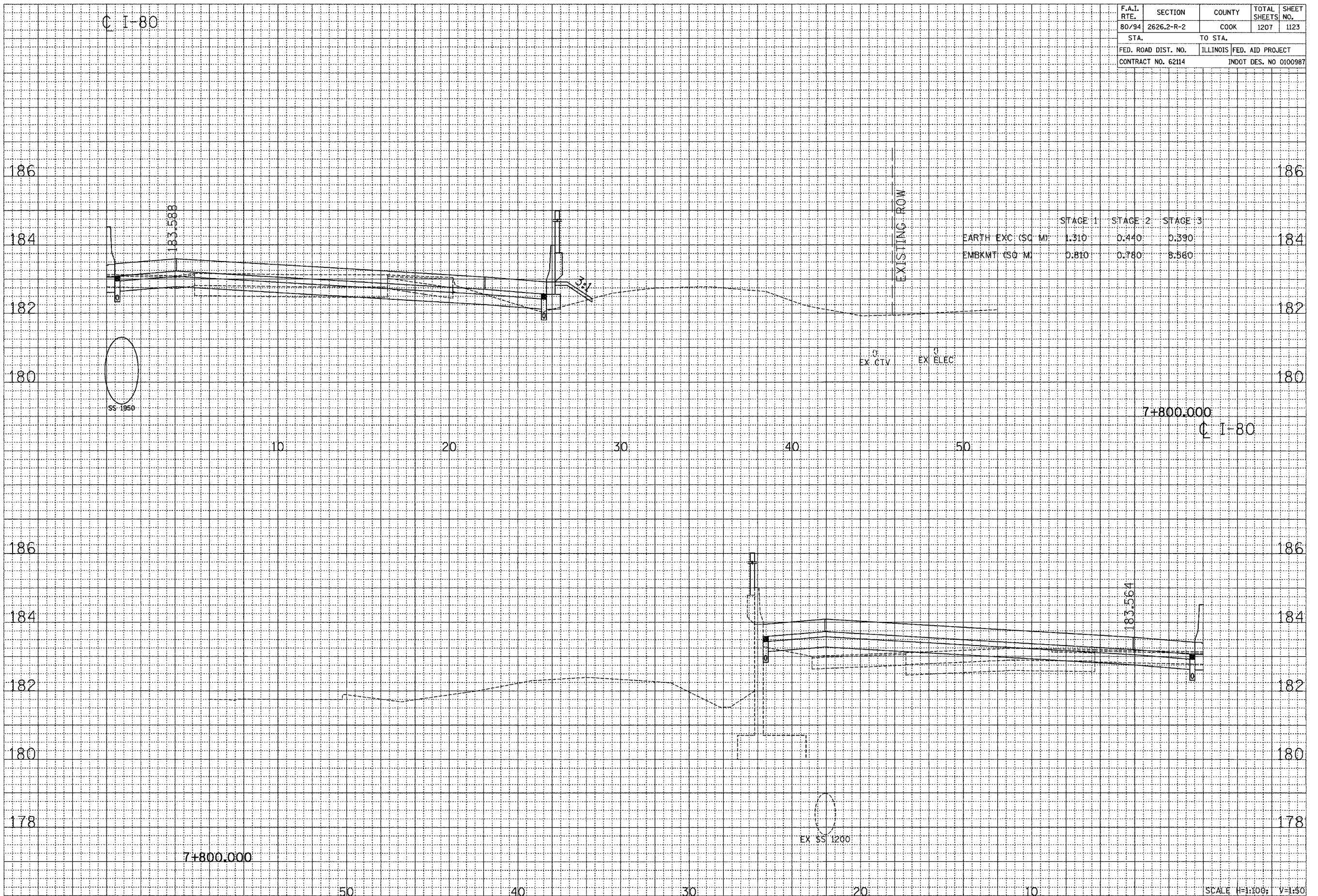

CROSS SECTION - I-80/94/US 6

...Users\ashb11a res 08/12/2005 09:51:17 AM

C I-80

F.A.L. RTE.	SECTION	COUNTY	TOTAL SHEETS	SHEET NO.
80/94	2626.2-R-2	COOK	1207	1124
STA.		TO STA.		
FED. ROAD DIST. NO.		ILLINOIS	FED. AID PROJECT	
CONTRACT NO. 62114		INDOT DES. NO 0100987		

FINAL SURVEY	DATE
SURVEYED BY	BY
NOTE BOOK NO.	DATE
TEMPLATE	
AREAS CHECKED	
AREAS CHECKED	

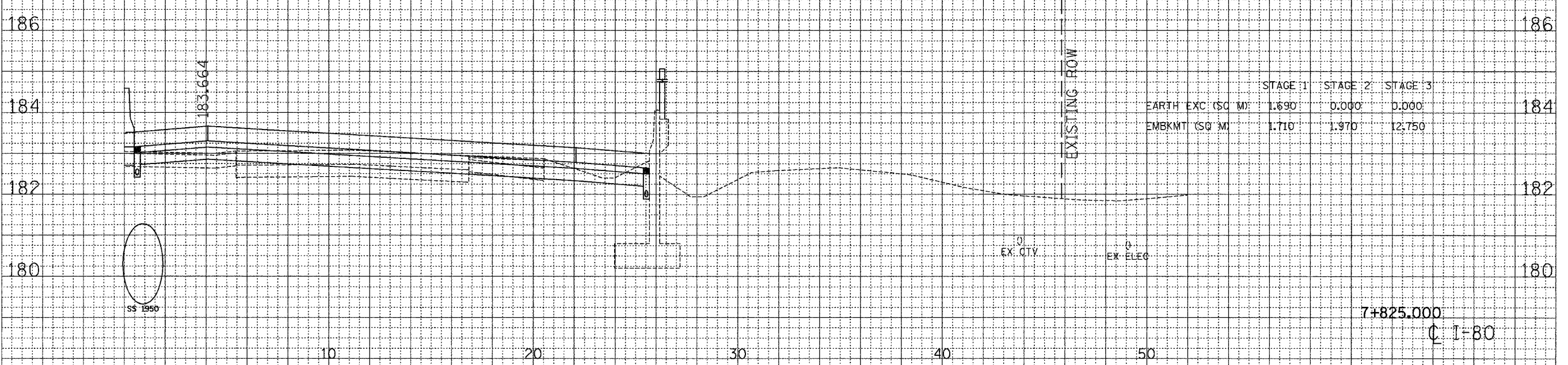

ORIGINAL SURVEY	DATE
SURVEYED BY	BY
NOTE BOOK NO.	DATE
TEMPLATE	
AREAS CHECKED	
AREAS CHECKED	

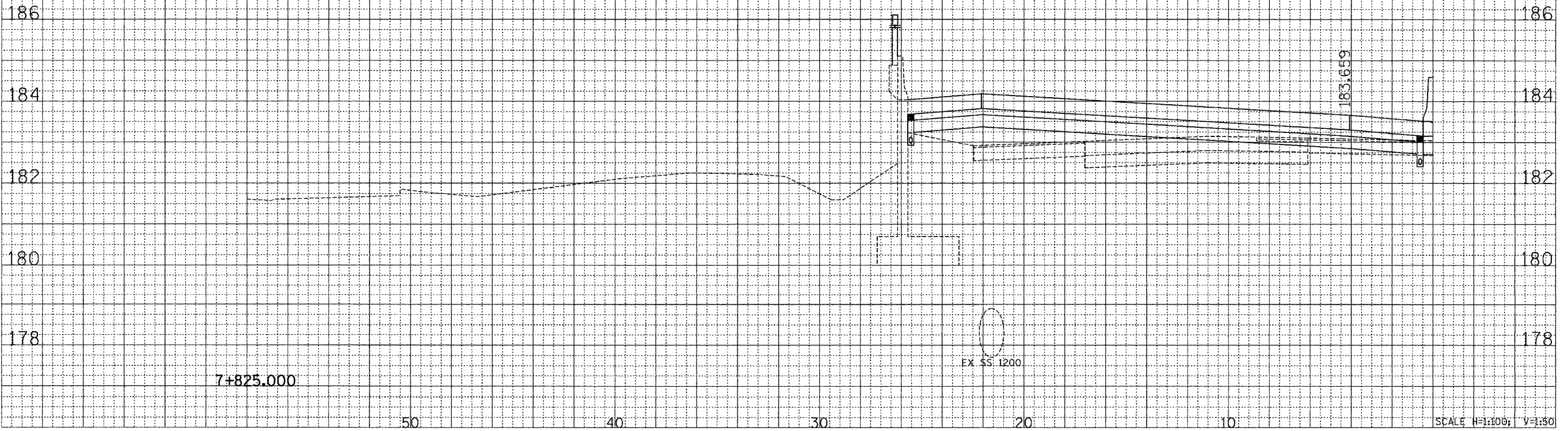

SCALE H=1:100; V=1:50

CROSS SECTION - I-80/94/US 6

F.A.I. RTE.	SECTION	COUNTY	TOTAL SHEETS	SHEET NO.
80/94	2626.2-R-2	COOK	1207	1125
STA.		TO STA.		
FED. ROAD DIST. NO.		ILLINOIS	FED. AID PROJECT	
CONTRACT NO. 62114		INDOT DES. NO 0100987		

FINAL SURVEY	DATE
BY	
REVISIONS	
NO.	

ORIGINAL SURVEY	DATE
BY	
REVISIONS	
NO.	

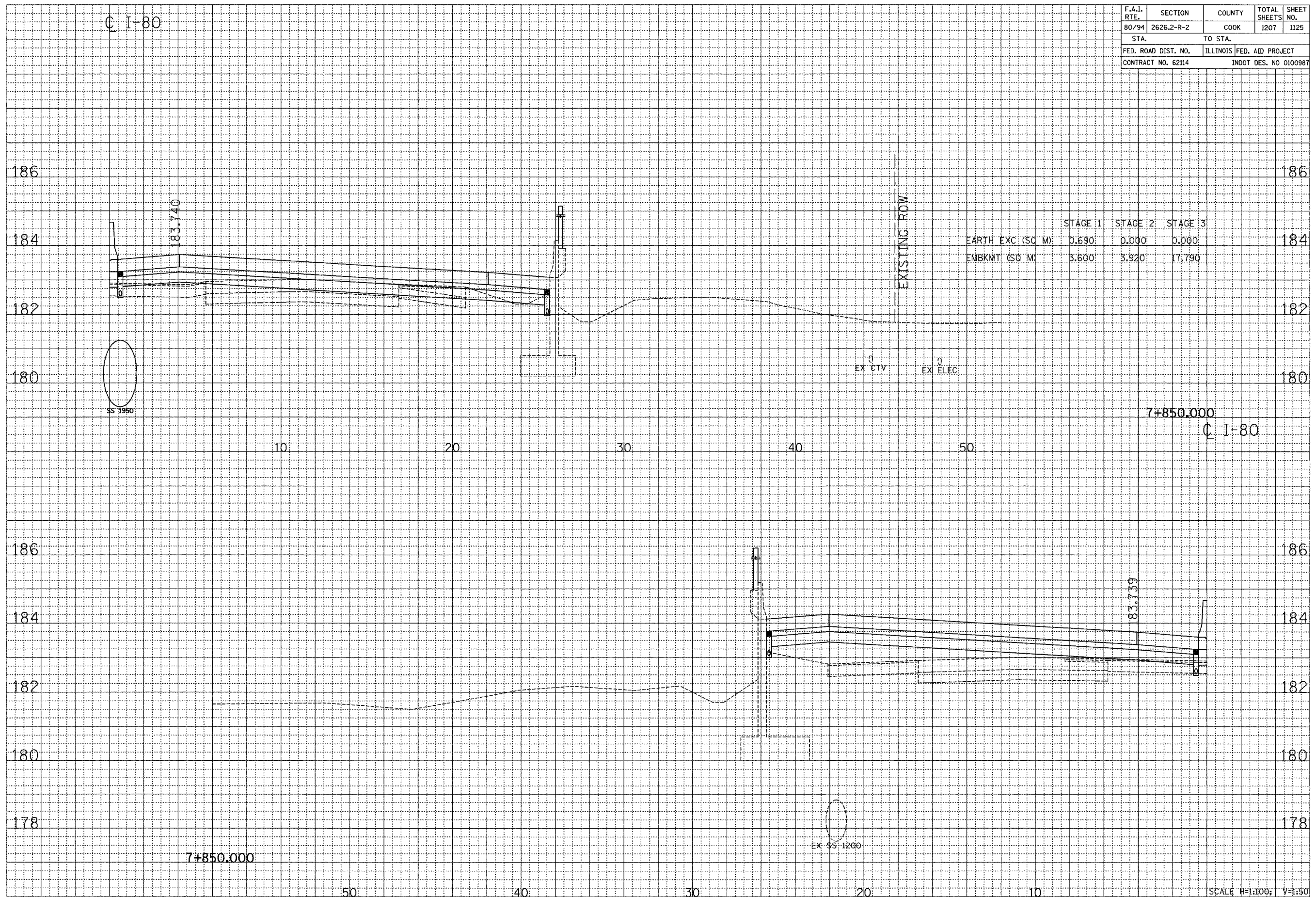

CROSS SECTION - I-80/94/US 6

Scale H=1:100; V=1:50

F.A.I. RTE.	SECTION	COUNTY	TOTAL SHEETS	SHEET NO.
80/94	2626.2-R-2	COOK	1207	1126
STA.		TO STA.		
FED. ROAD DIST. NO.		ILLINOIS	FED. AID PROJECT	
CONTRACT NO. 62114		INDOT DES. NO 0100987		

FINAL SURVEY	BY	DATE
BLANKETED		
PLOTTED		
NOTE BOOK		
NO.		
AREAS CHECKED		

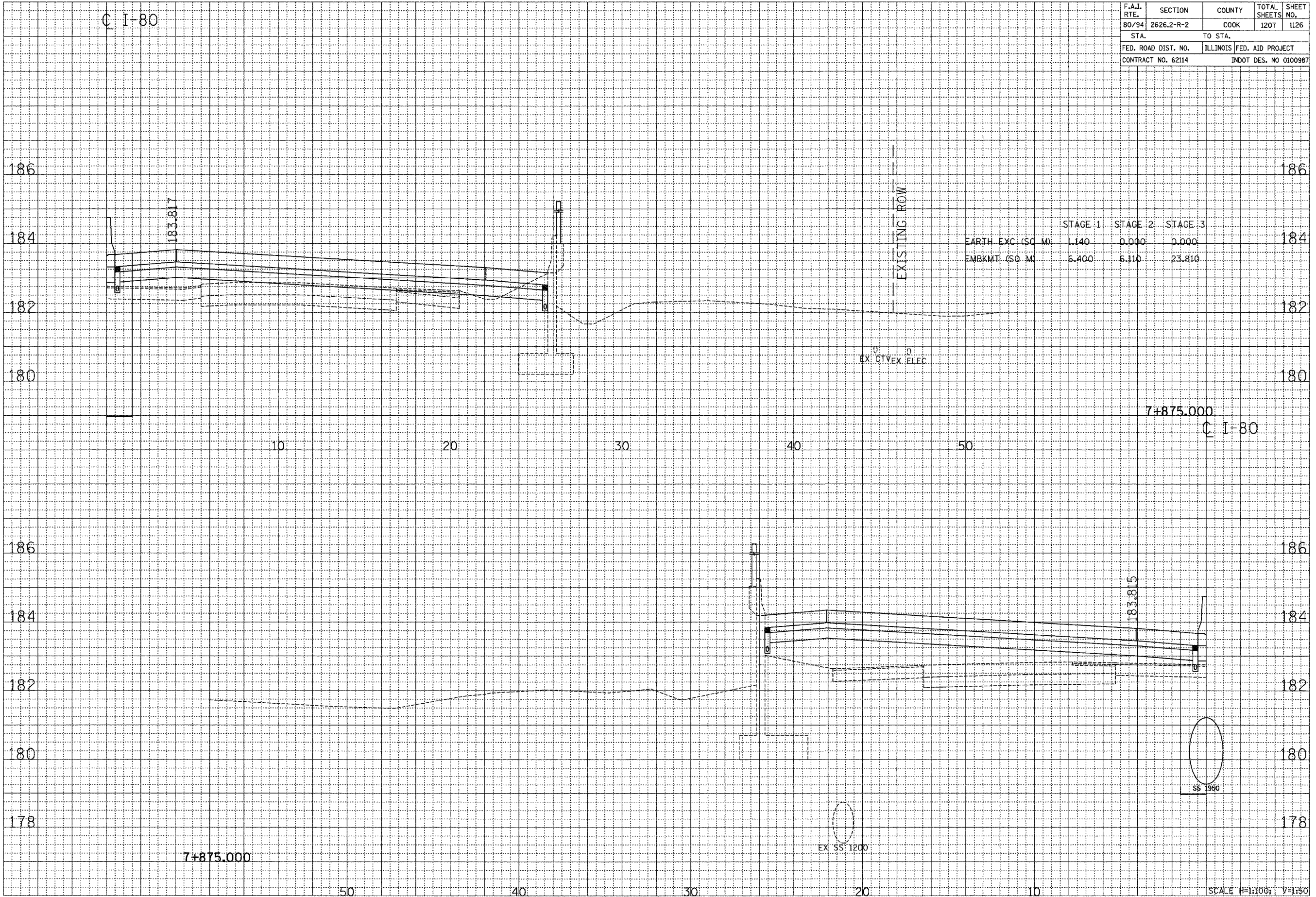

ORIGINAL SURVEY	BY	DATE
BLANKETED		
PLOTTED		
NOTE BOOK		
NO.		
AREAS CHECKED		

CROSS SECTION - I-80/94/US 6

Vertical: 06/15/2005 08:51:35 AM

F.A.I. RTE. 80/94	SECTION 2626.2-R-2	COUNTY COOK	TOTAL SHEETS 1207	SHEET NO. 1127
STA.		TO STA.		
FED. ROAD DIST. NO.		ILLINOIS FED. AID PROJECT		
CONTRACT NO. 62114		INDOT DES. NO 0100987		

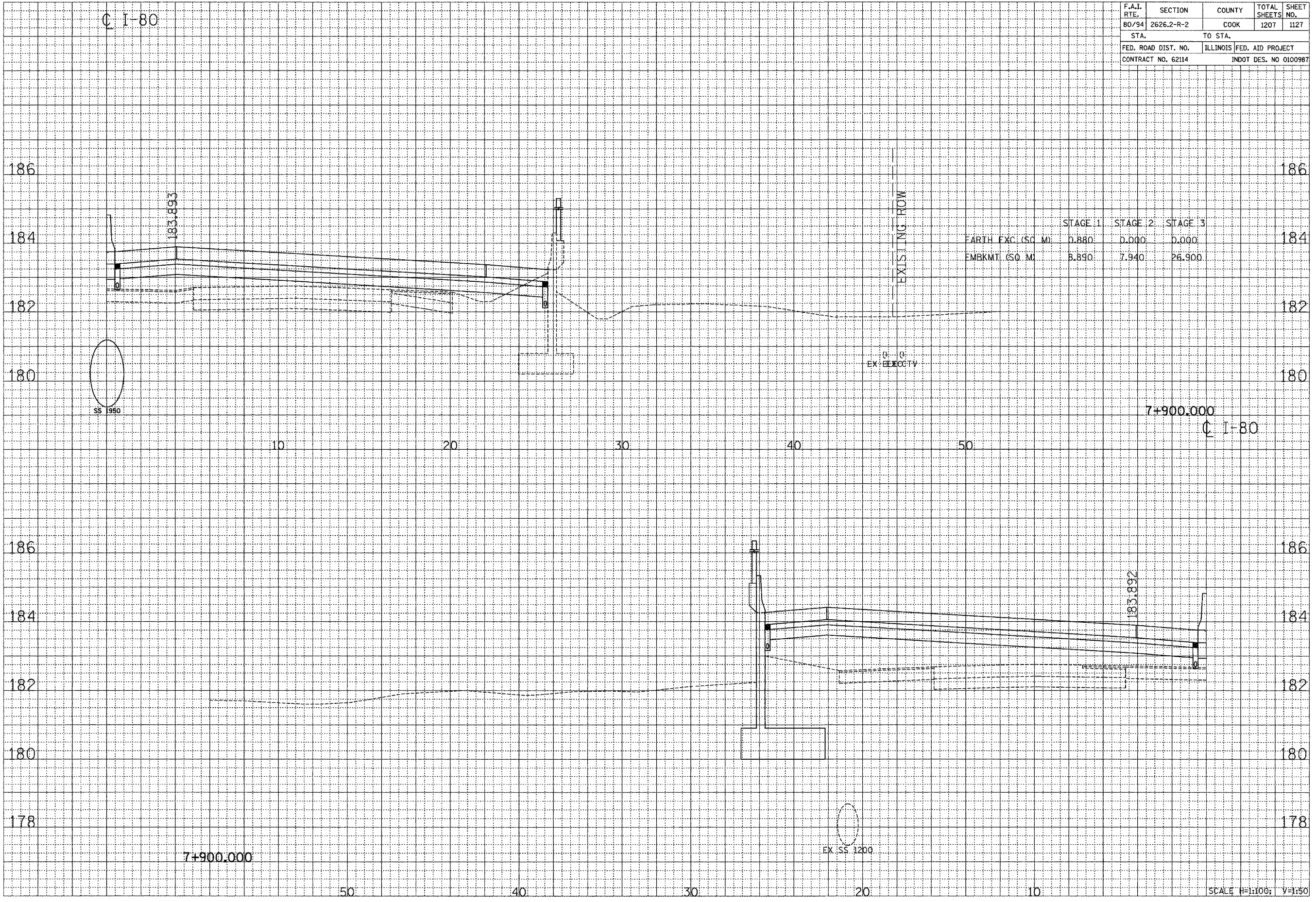

BY	DATE
BY	DATE
BY	DATE
BY	DATE

BY	DATE
BY	DATE
BY	DATE
BY	DATE

CROSS SECTION - I-80/94/US 6

...America's VeriSoft/114 750 09/12/2005 09:51:40 AM

F.A.I. RTE.	SECTION	COUNTY	TOTAL SHEETS	SHEET NO.
80/94	2626.2-R-2	COOK	1207	1128
STA.		TO STA.		
FED. ROAD DIST. NO.		ILLINOIS	FED. AID PROJECT	
CONTRACT NO. 62114		INDOT DES. NO 0100987		

FINAL SURVEY	DATE
EMBARVED	BY
PLOTTED	
NOTE BOOK	
AREAS	
CHECKED	

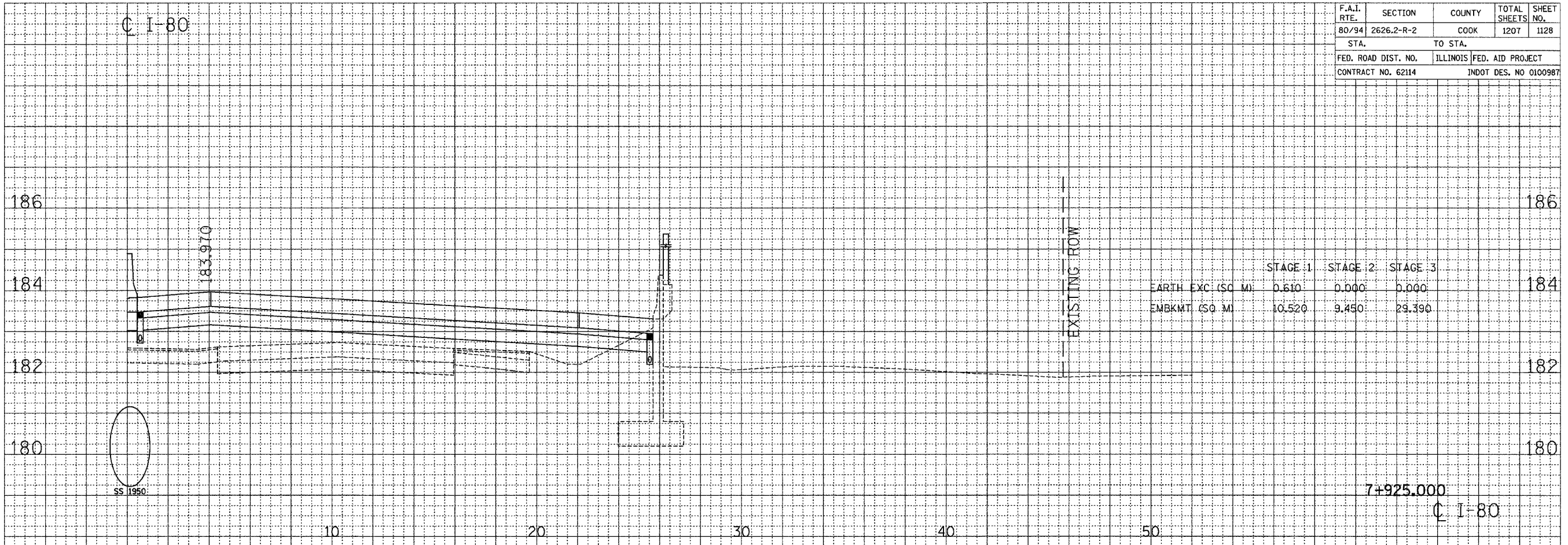

ORIGINAL SURVEY	DATE
EMBARVED	BY
PLOTTED	
NOTE BOOK	
AREAS	
CHECKED	

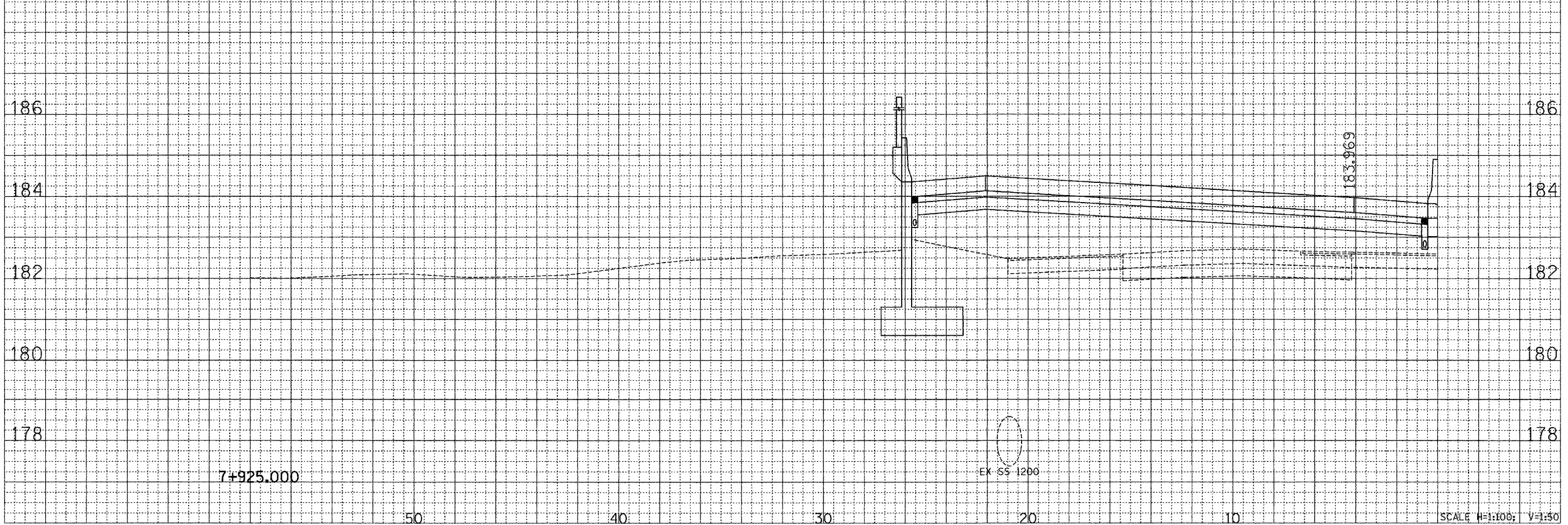

CROSS SECTION - I-80/94/US 6

Scale H=1:100; V=1:50

F.A.I. RTE.	SECTION	COUNTY	TOTAL SHEETS	SHEET NO.
80/94	2626.2-R-2	COOK	1207	1129
STA.		TO STA.		
FED. ROAD DIST. NO.		ILLINOIS	FED. AID PROJECT	
CONTRACT NO. 62114		INDOT DES. NO 0100987		

FINAL SURVEY	BY	DATE
NOTE BOOK NO.		
AREAS CHECKED		

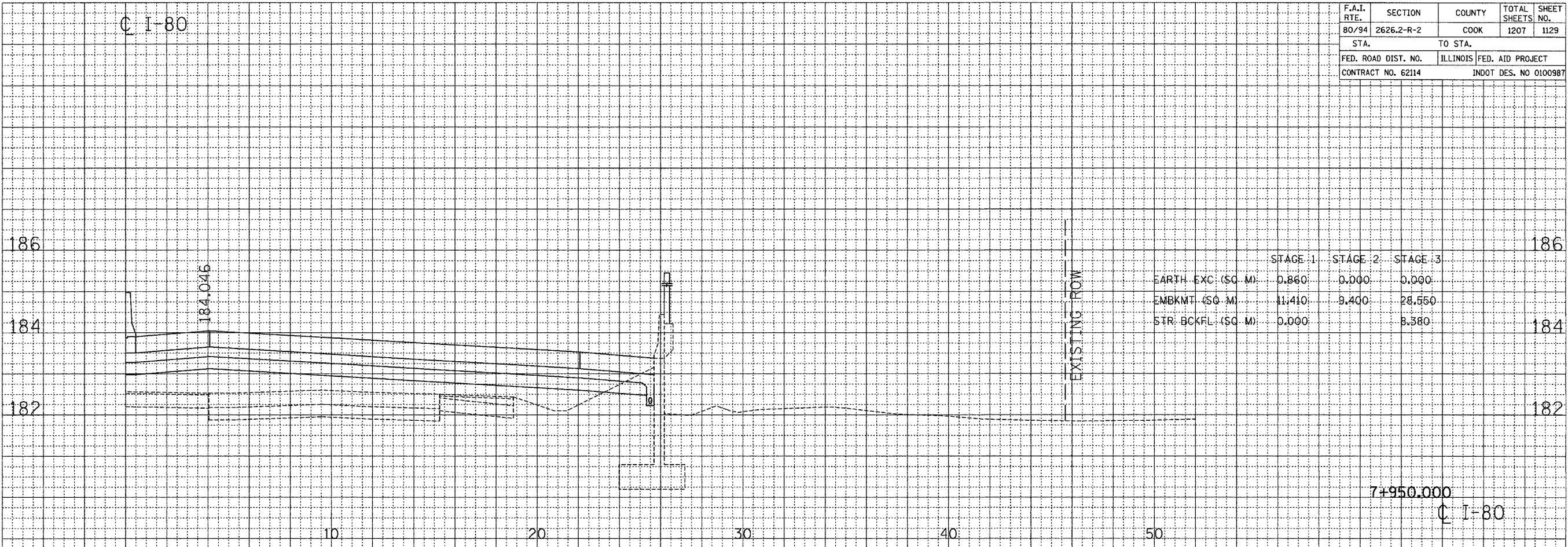

ORIGINAL SURVEY	BY	DATE
NOTE BOOK NO.		
AREAS CHECKED		

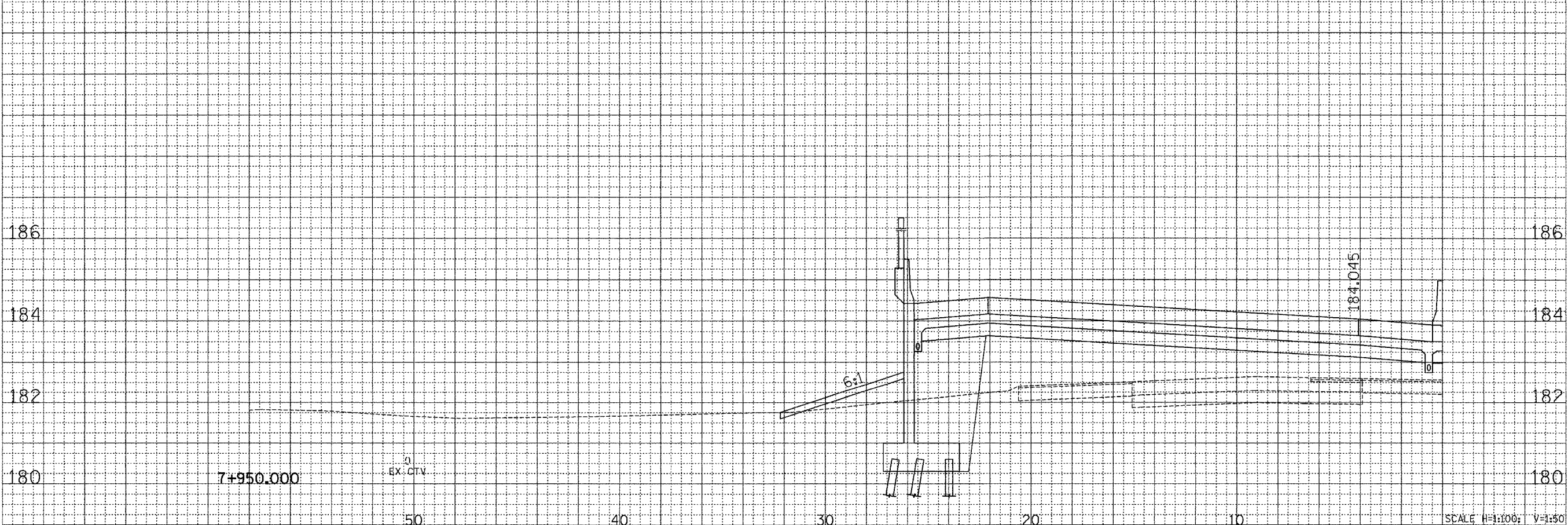

CROSS SECTION - I-80/94/US 6

Scale H=1:100; V=1:50

C I-80

F.A.I. RTE.	SECTION	COUNTY	TOTAL SHEETS	SHEET NO.
80/94	2626.2-R-2	COOK	1207	1130
STA.		TO STA.		
FED. ROAD DIST. NO.		ILLINOIS FED. AID PROJECT		
CONTRACT NO. 62114		INDOT DES. NO 0100987		

FINAL SURVEY	BY	DATE
NO. _____	_____	_____
REVISIONS	BY	DATE
NO. _____	_____	_____
APPROVED	BY	DATE
NO. _____	_____	_____

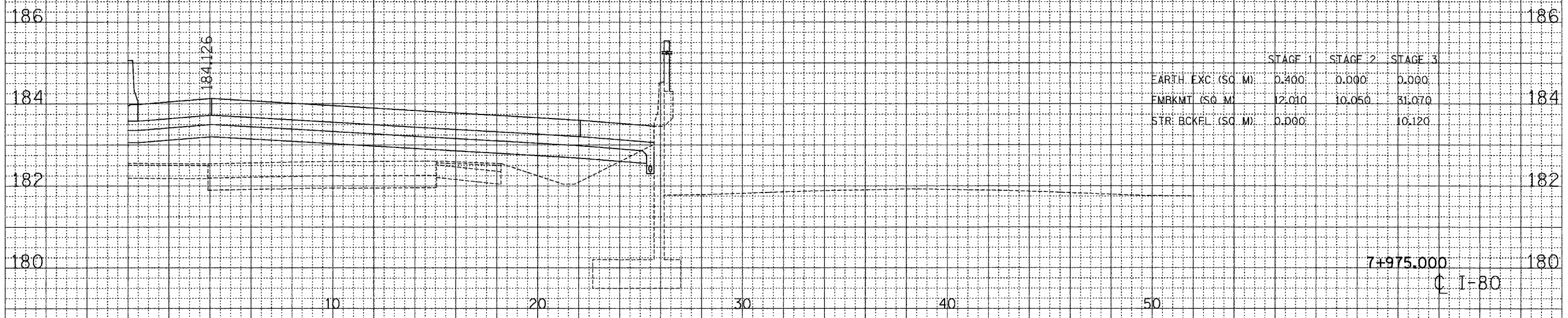

ORIGINAL SURVEY	BY	DATE
NO. _____	_____	_____
REVISIONS	BY	DATE
NO. _____	_____	_____
APPROVED	BY	DATE
NO. _____	_____	_____

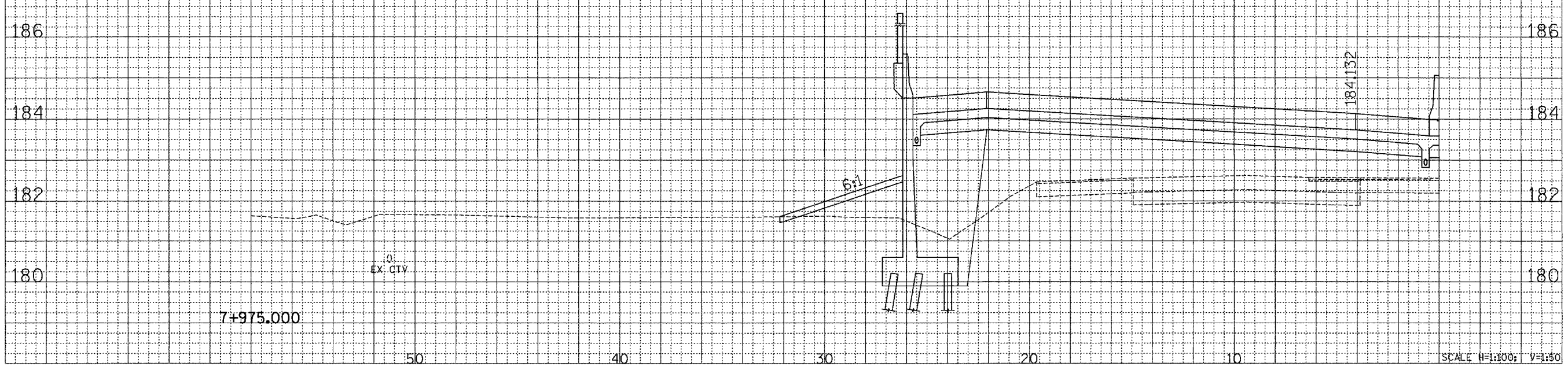

CROSS SECTION - I-80/94/US 6

Scale H=1:100; V=1:50

F.A.I. RTE.	SECTION	COUNTY	TOTAL SHEETS	SHEET NO.
80/94	2626.2-R-2	COOK	1207	1131
STA.		TO STA.		
FED. ROAD DIST. NO.		ILLINOIS FED. AID PROJECT		
CONTRACT NO. 62114		INDOT DES. NO 0100987		

FINAL SURVEY	DATE
SURVEYED	BY
PLOTTED	
NOTE BOOK NO.	
AREAS DATE	
AREAS CHECKED	

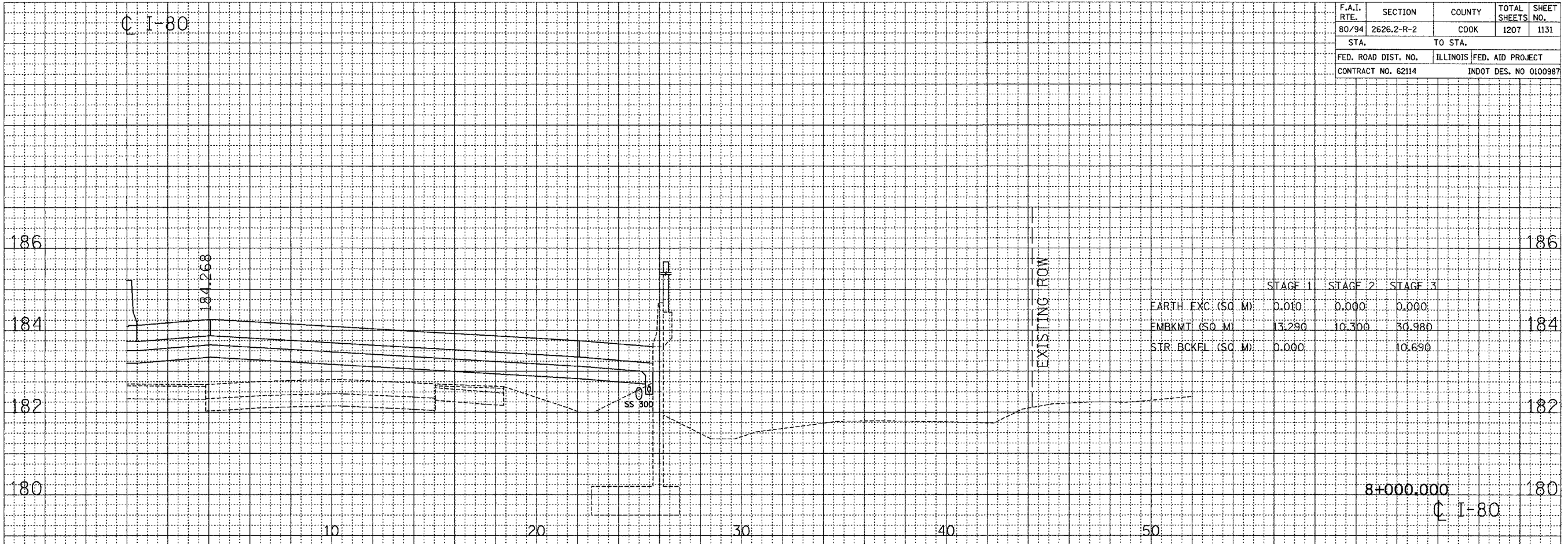

ORIGINAL SURVEY	DATE
SURVEYED	BY
PLOTTED	
NOTE BOOK NO.	
AREAS DATE	
AREAS CHECKED	

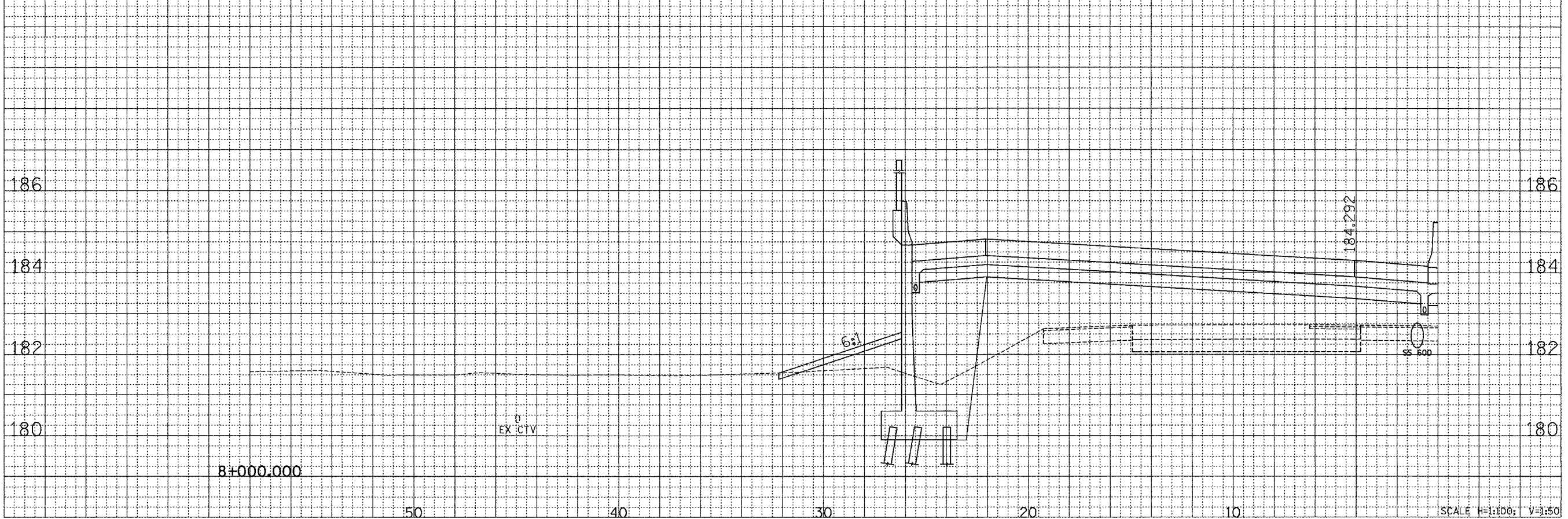

CROSS SECTION - I-80/94/US 6

Scale H=1:100; V=1:50

C I-80

F.A.I. RTE.	SECTION	COUNTY	TOTAL SHEETS	SHEET NO.
80/94	2626.2-R-2	COOK	1207	1132
STA.		TO STA.		
FED. ROAD DIST. NO.		ILLINOIS	FED. AID PROJECT	
CONTRACT NO. 62114		INDOT DES. NO 0100987		

FINAL SURVEY	BY	DATE
SURVEYED		
NOTE BOOK		
NO.		
AREAS CHECKED		

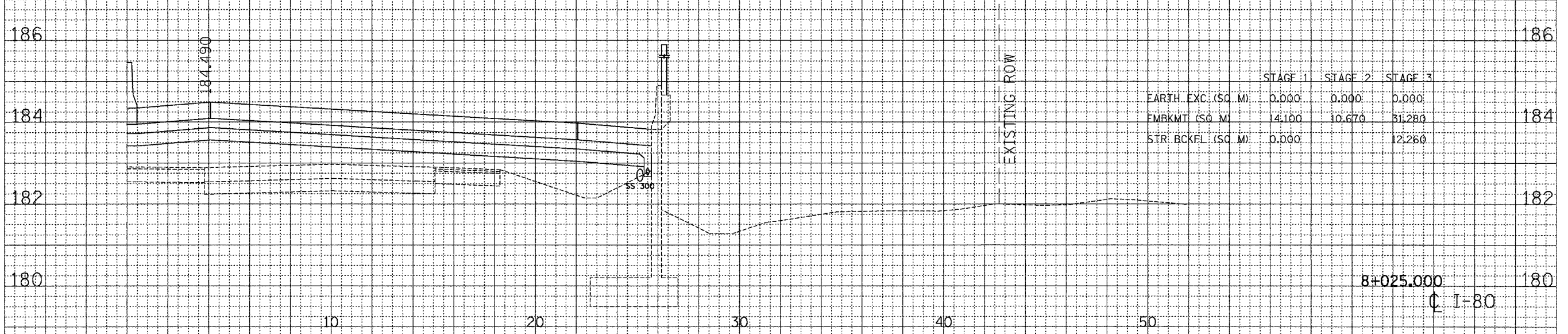

ORIGINAL SURVEY	BY	DATE
SURVEYED		
NOTE BOOK		
NO.		
AREAS CHECKED		

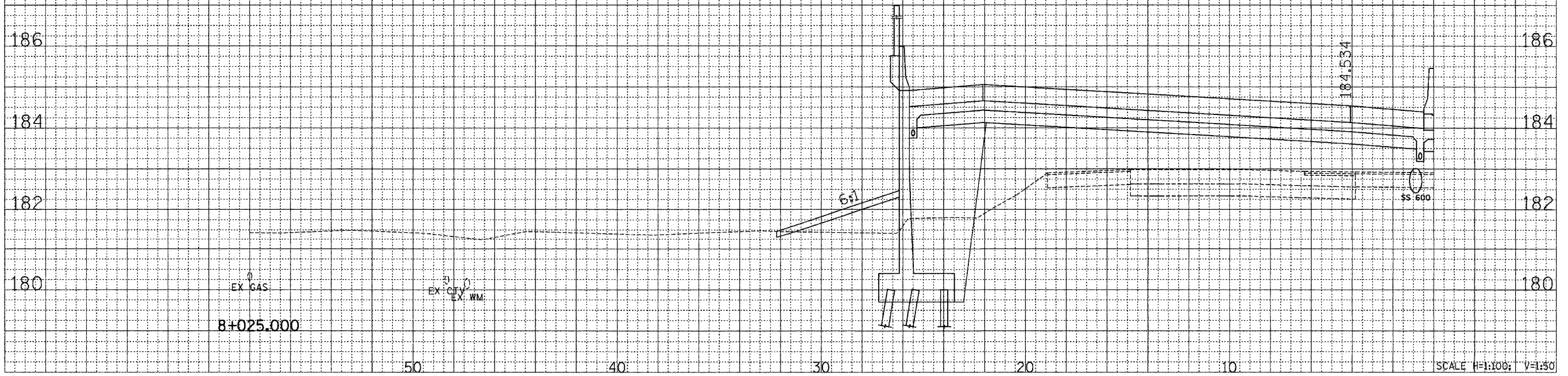

SCALE H=1:100; V=1:50
CROSS SECTION - I-80/94/US 6

\\spw11s0011a.ccs 05/11/2006 11:47:57 AM

C I-80

F.A.I. RTE.	SECTION	COUNTY	TOTAL SHEETS	SHEET NO.
80/94	2626.2-R-2	COOK	1207	1133
STA.		TO STA.		
FED. ROAD DIST. NO.	ILLINOIS	FED. AID PROJECT		
CONTRACT NO. 62114	INDOT DES. NO 0100987			

FINAL SURVEY
NOTE BOOK NO. _____
DATE _____
BY _____
APPROVED BY _____

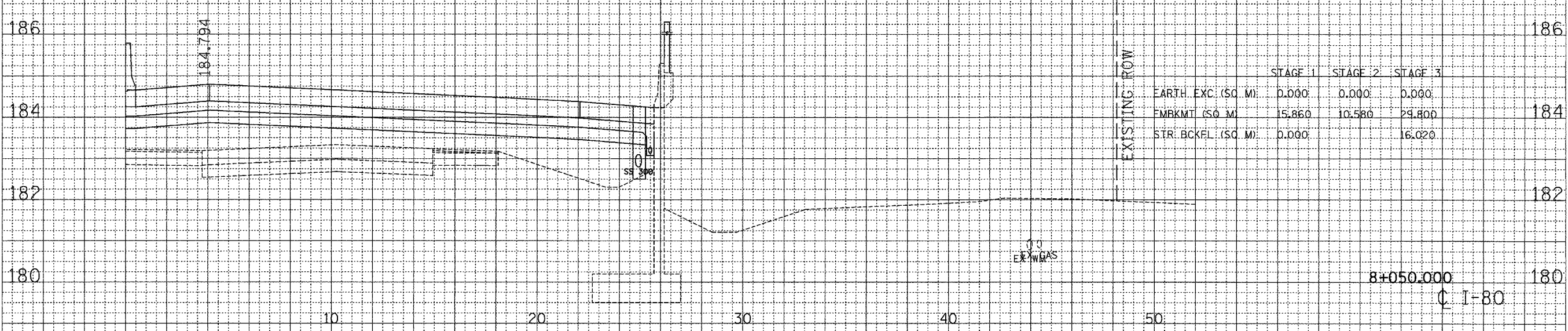

ORIGINAL SURVEY
NOTE BOOK NO. _____
DATE _____
BY _____
APPROVED BY _____

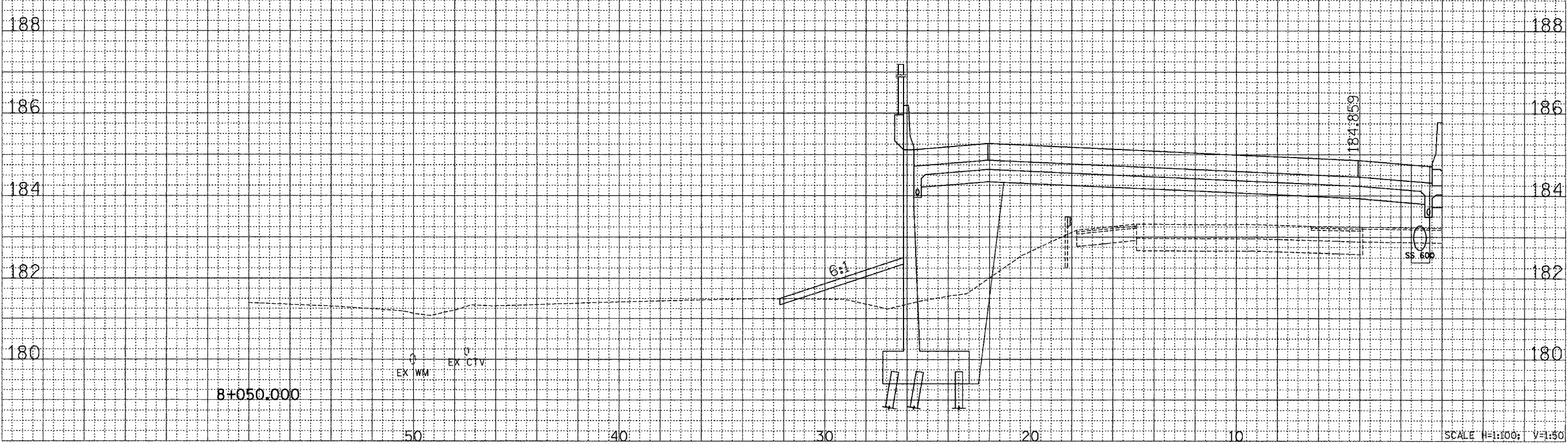

CROSS SECTION - I-80/94/US 6

SCALE H=1:100; V=1:50

C I-80

F.A.I. RTE.	SECTION	COUNTY	TOTAL SHEETS	SHEET NO.
80/94	2626.2-R-2	COOK	1207	1134
STA.		TO STA.		
FED. ROAD DIST. NO.		ILLINOIS	FED. AID PROJECT	
CONTRACT NO. 62114		INDOT DES. NO 0100987		

FINAL SURVEY	DATE
BY	
SURVEYED	
TEMPLATE	
AREAS	
CHECKED	
NO.	

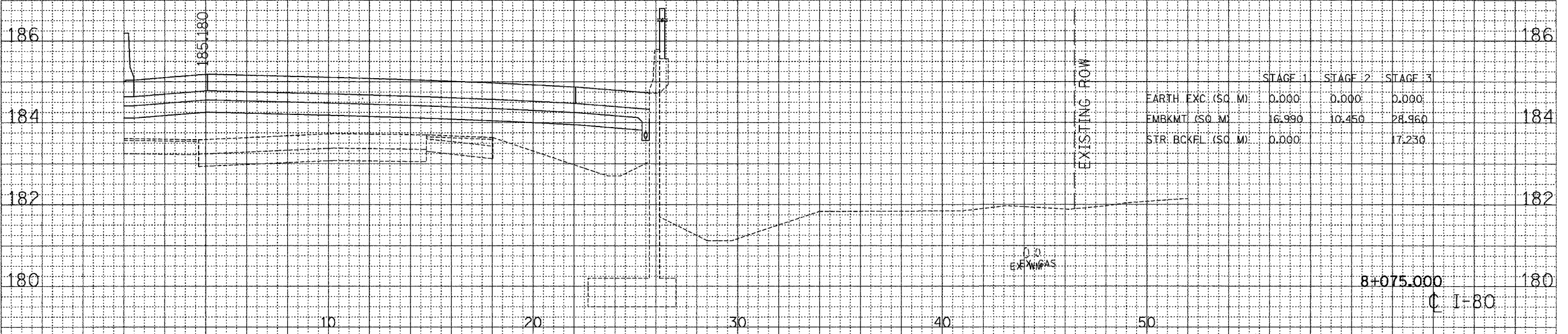

ORIGINAL SURVEY	DATE
BY	
SURVEYED	
TEMPLATE	
AREAS	
CHECKED	
NO.	

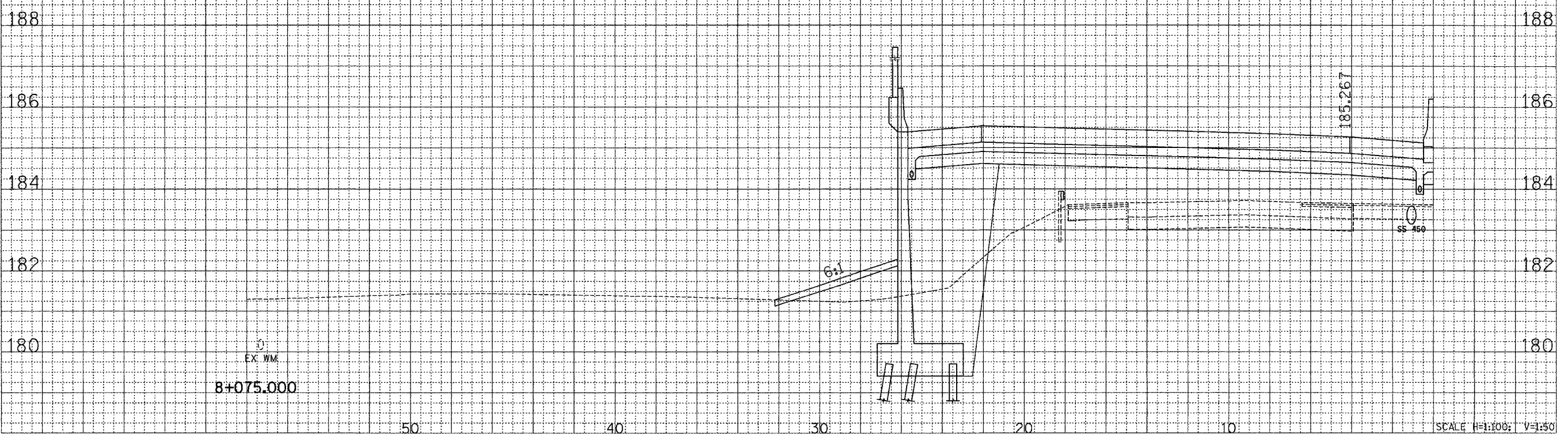

CROSS SECTION - I-80/94/US 6

...:\Sweat\181011a.dwg 06/11/2005 11:47:50 AM

F.A.I. RTE.	SECTION	COUNTY	TOTAL SHEETS	SHEET NO.
80/94	2626.2-R-2	COOK	1207	1135
STA.		TO STA.		
FED. ROAD DIST. NO.		ILLINOIS FED. AID PROJECT		
CONTRACT NO. 62114		INDOT DES. NO 0100987		

FINAL SURVEY	DATE
BLANKET	
PLOTTED	
AREAS	
NO. CHECKED	

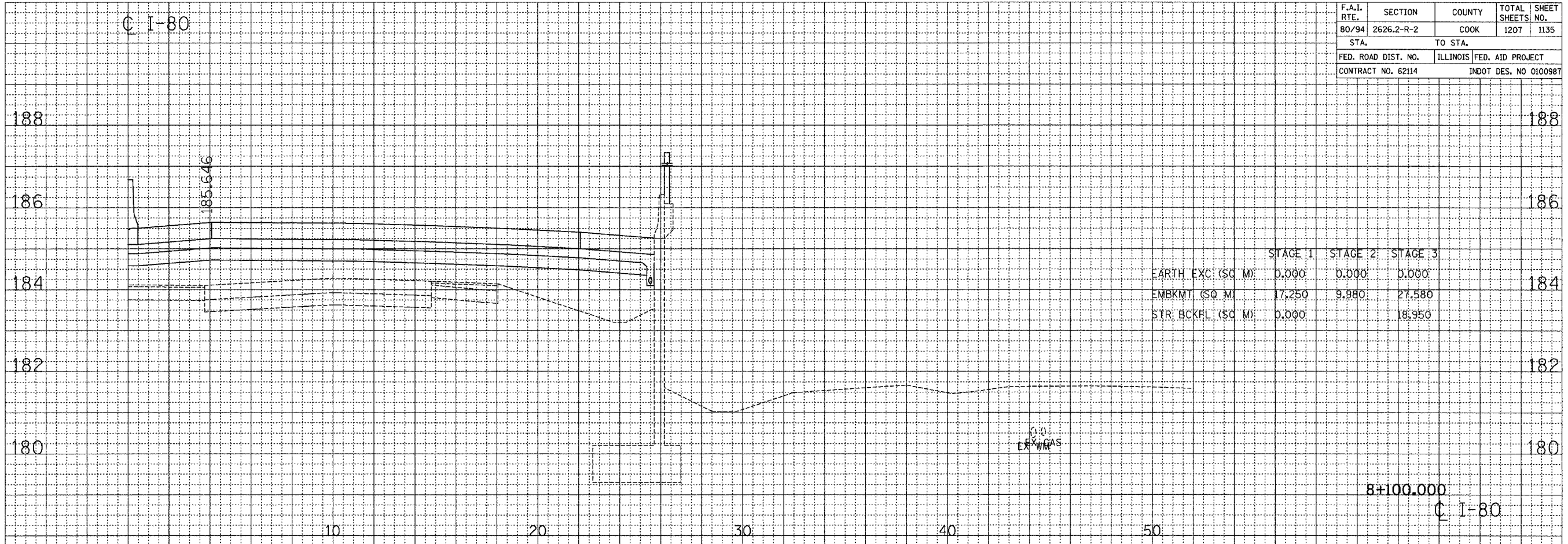

ORIGINAL SURVEY	DATE
BLANKET	
PLOTTED	
AREAS	
NO. CHECKED	

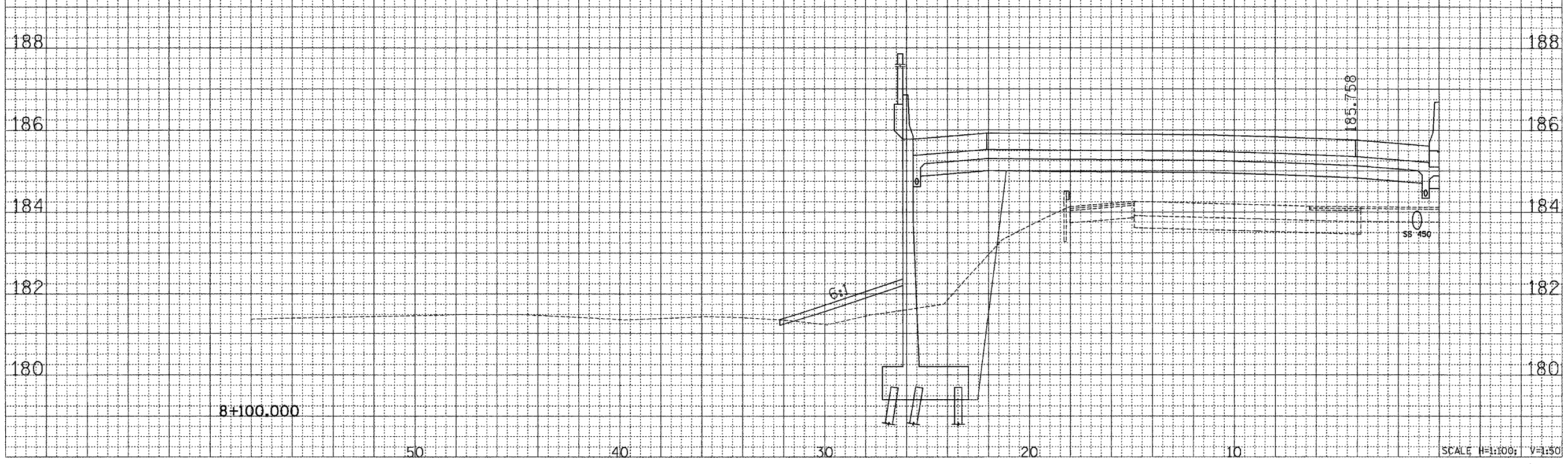

CROSS SECTION - I-80/94/US 6

Scale H=1:100; V=1:50

F.A.I. RTE.	SECTION	COUNTY	TOTAL SHEETS	SHEET NO.
80/94	2626.2-R-2	COOK	1207	1136
STA.		TO STA.		
FED. ROAD DIST. NO.		ILLINOIS	FED. AID PROJECT	
CONTRACT NO. 62114		INDOT DES. NO 0100987		

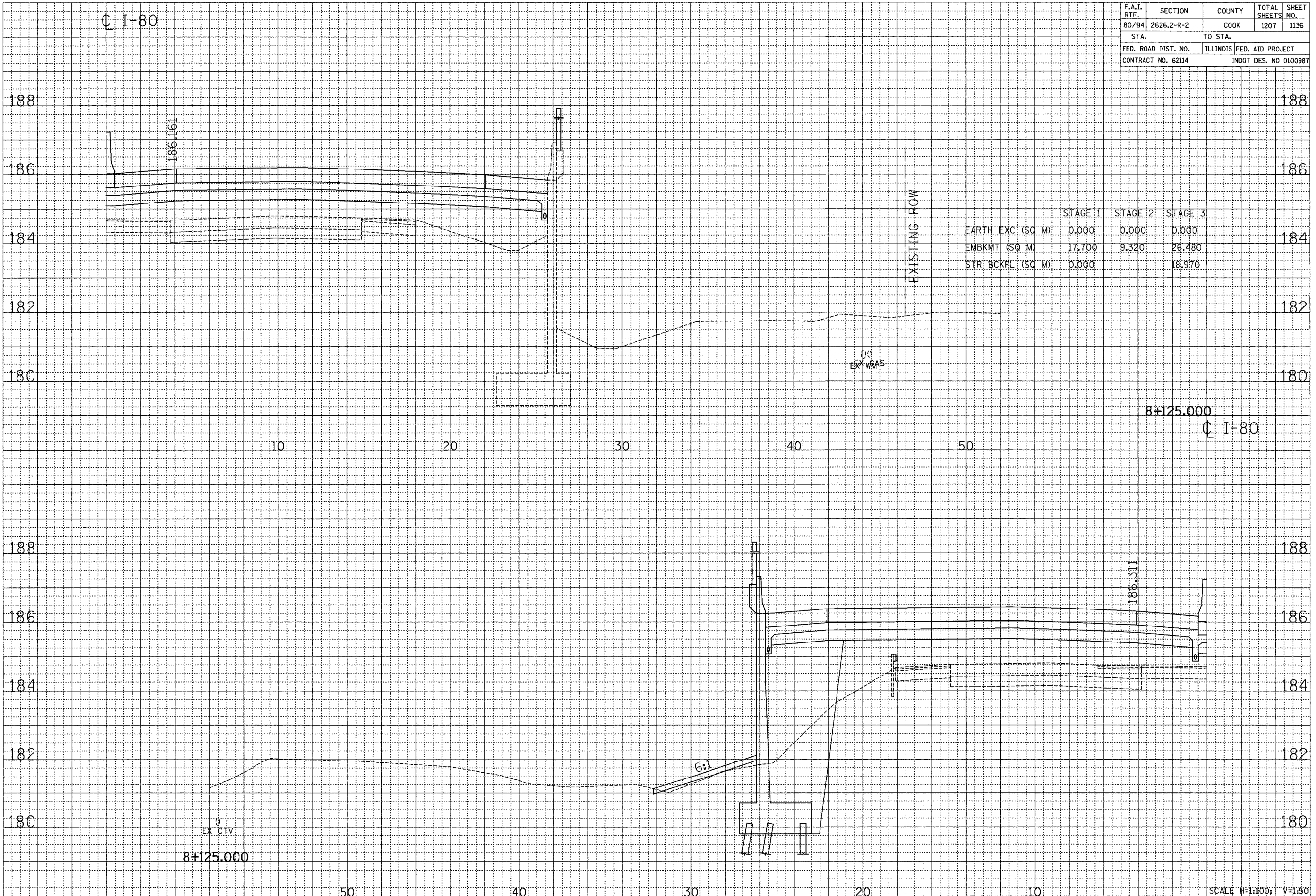

	STAGE 1	STAGE 2	STAGE 3
EARTH EXC (SQ M)	0.000	0.000	0.000
EMBKMT (SQ M)	17.700	9.320	26.480
STR. BCKFL (SQ M)	0.000		18.970

FINAL SURVEY	DATE
SURVEYED	
PLOTTED	
NOTE BOOK	
AREAS CHECKED	
NO.	

ORIGINAL SURVEY	DATE
SURVEYED	
PLOTTED	
NOTE BOOK	
AREAS CHECKED	
NO.	

CROSS SECTION - I-80/94/US 6

SCALE H=1:100; V=1:50

F.A.I. RTE.	SECTION	COUNTY	TOTAL SHEETS	SHEET NO.
80/94	2626.2-R-2	COOK	1207	1137
STA.		TO STA.		
FED. ROAD DIST. NO.	ILLINOIS	FED. AID PROJECT		
CONTRACT NO. 62114	INDOT DES. NO 0100987			

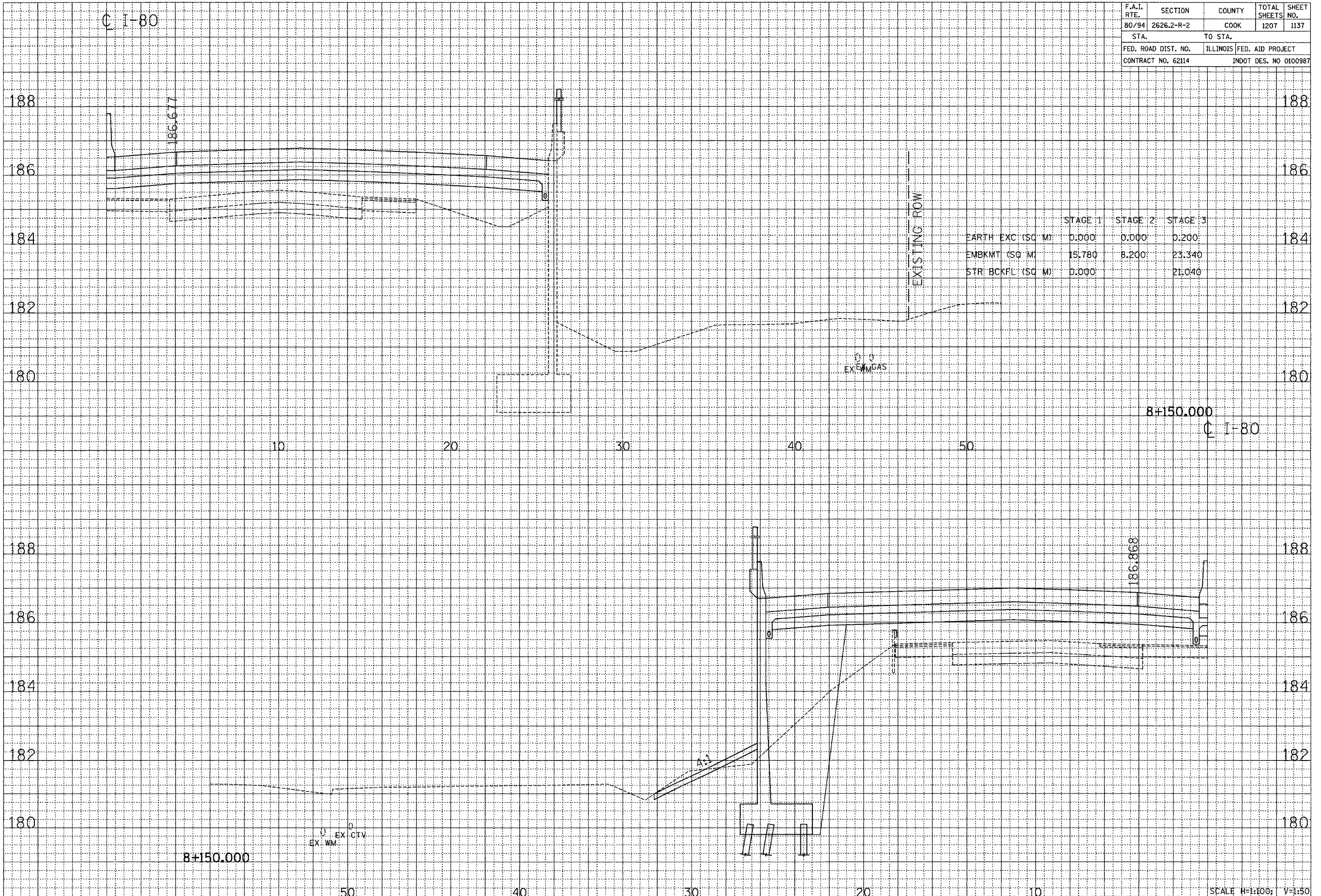

FINAL SURVEY	DATE
REVISION	BY
NOTE BOOK	
NO.	

ORIGINAL SURVEY	DATE
REVISION	BY
NOTE BOOK	
NO.	

F.A.I. RTE.	SECTION	COUNTY	TOTAL SHEETS	SHEET NO.
80/94	2626.2-R-2	COOK	1207	1138
STA.		TO STA.		
FED. ROAD DIST. NO.		ILLINOIS FED. AID PROJECT		
CONTRACT NO. 62114		INDOT DES. NO 0100987		

FINAL SURVEY	DATE
BURNED SURVEY	BY
NOTE BOOK	
NO.	
AREAS CHECKED	

ORIGINAL SURVEY	DATE
BURNED SURVEY	BY
NOTE BOOK	
NO.	
AREAS CHECKED	

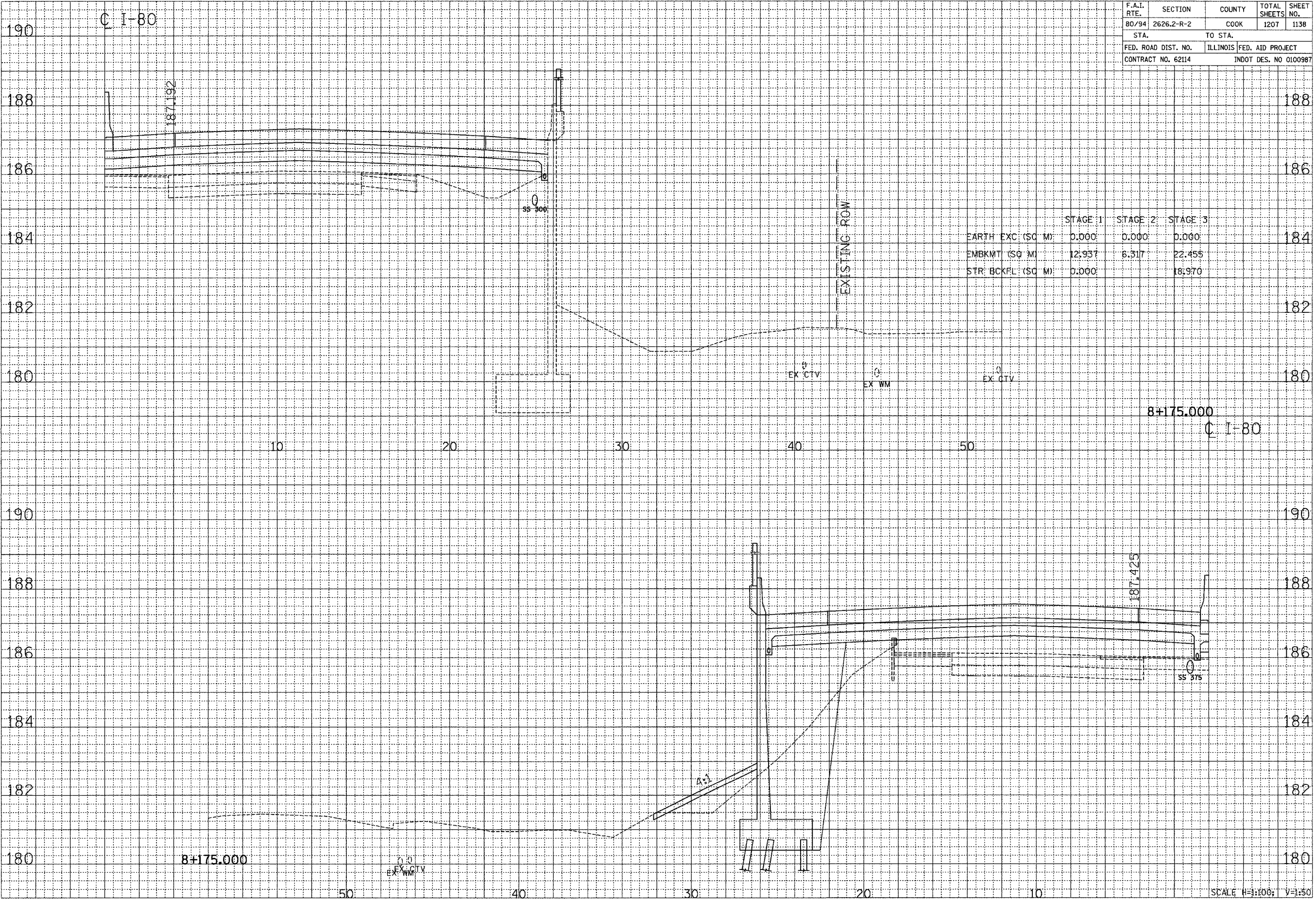

CROSS SECTION - I-80/94/US 6

...:\Sheets\I-80\1138.mxd 05/14/2005 08:58:25 AM

F.A.I. RTE.	SECTION	COUNTY	TOTAL SHEETS	SHEET NO.
80/94	2626.2-R-2	COOK	1207	1139
STA.		TO STA.		
FED. ROAD DIST. NO.		ILLINOIS FED. AID PROJECT		
CONTRACT NO. 62114		INDOT DES. NO 0100987		

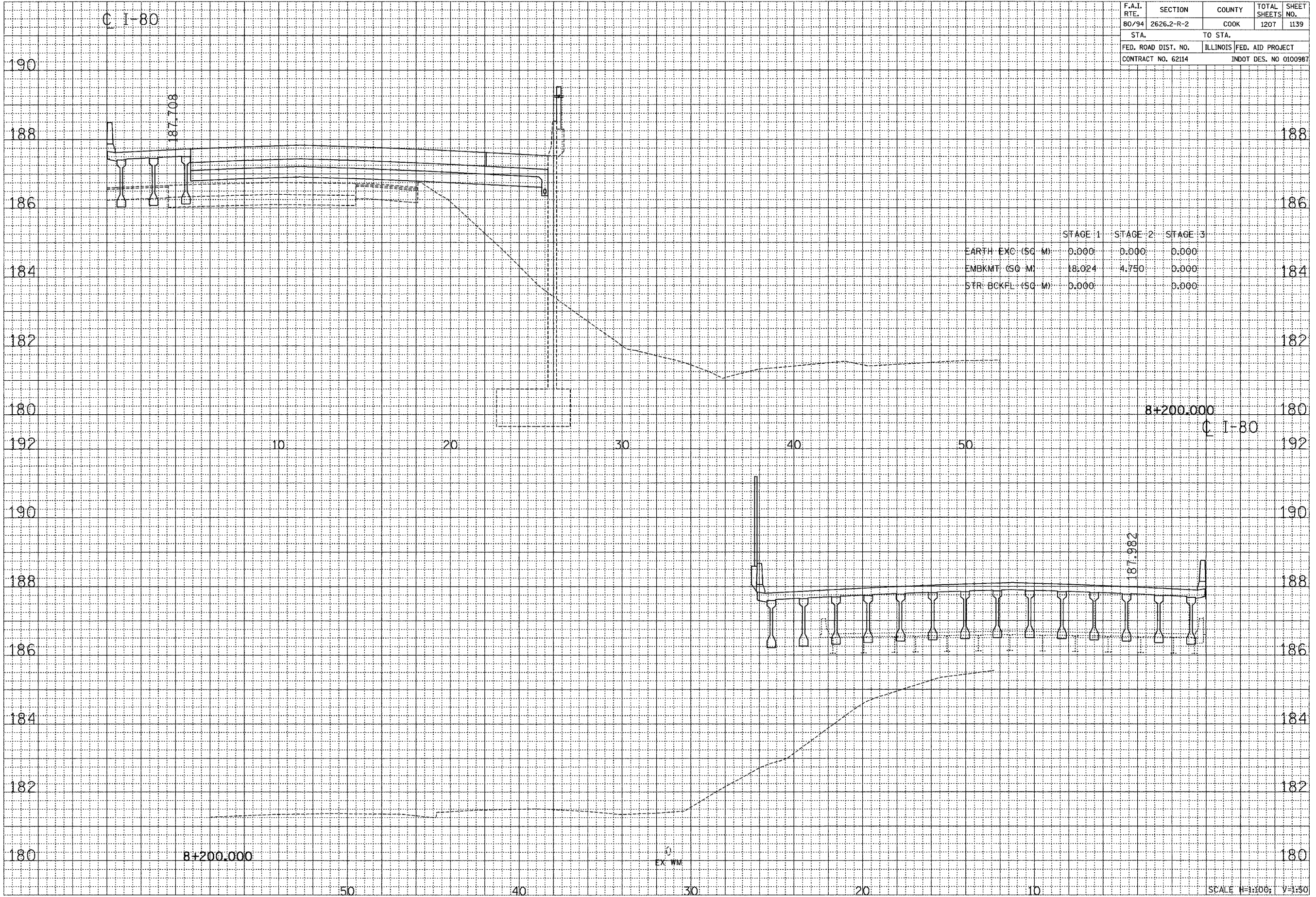

BY	DATE

BY	DATE

CROSS SECTION - I-80/94/US 6

\\share1\vs160511a.rbf 09/12/2005 08:56:36 AM

F.A.I. RTE.	SECTION	COUNTY	TOTAL SHEETS	SHEET NO.
80/94	2626.2-R-2	COOK	1207	1140
STA.		TO STA.		
FED. ROAD DIST. NO.		ILLINOIS	FED. AID PROJECT	
CONTRACT NO. 62114		INDOT DES. NO 0100987		

DATE	BY	DATE
ORIGINAL SURVEY	SHAWNEE	PLATTED
NOTE BOOK	NO. 1	DATE
		AREAS CHECKED

DATE	BY	DATE
ORIGINAL SURVEY	SHAWNEE	PLATTED
NOTE BOOK	NO. 1	DATE
		AREAS CHECKED

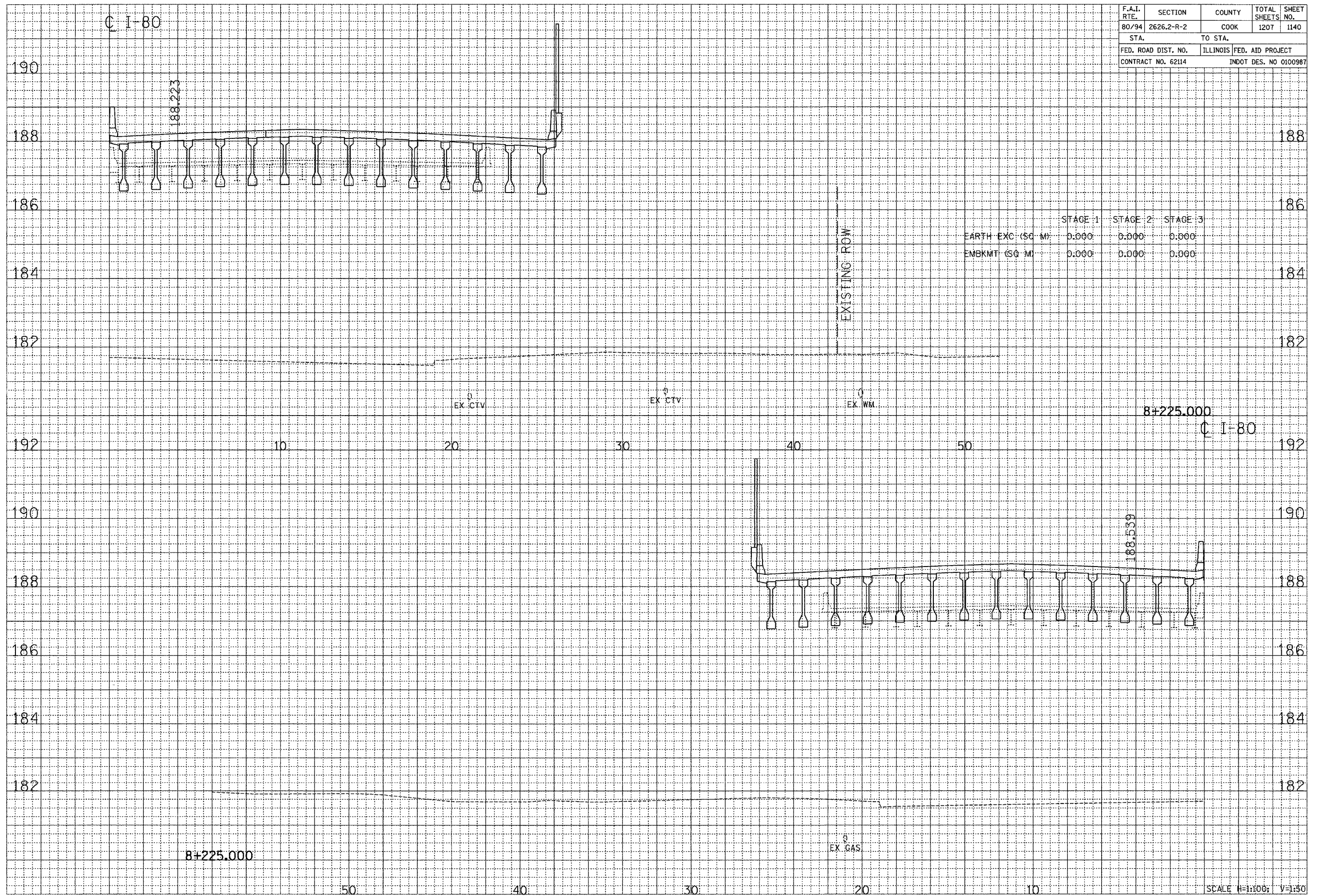

CROSS SECTION - I-80/94/US 6

F.A.I. RTE.	SECTION	COUNTY	TOTAL SHEETS	SHEET NO.
80/94	2626.2-R-2	COOK	1207	1141
STA.		TO STA.		
FED. ROAD DIST. NO.		ILLINOIS FED. AID PROJECT		
CONTRACT NO. 62114		INDOT DES. NO 0100987		

BY	DATE
FINAL SURVEY PLOTTED AREAS CHECKED	
NOTE BOOK NO.	

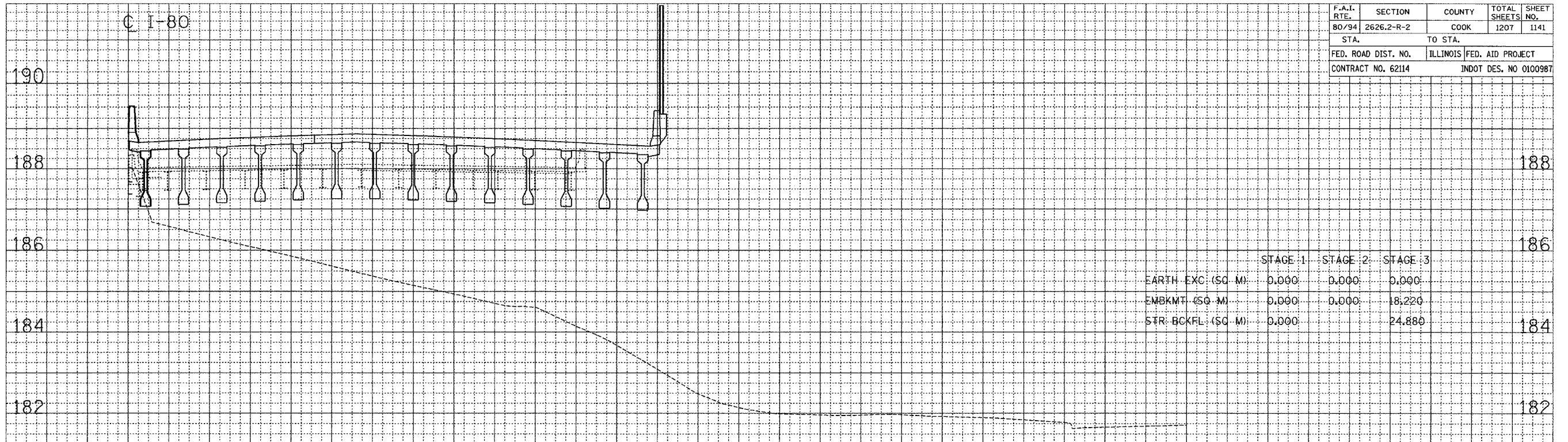

BY	DATE
ORIGINAL SURVEY PLOTTED AREAS CHECKED	
NOTE BOOK NO.	

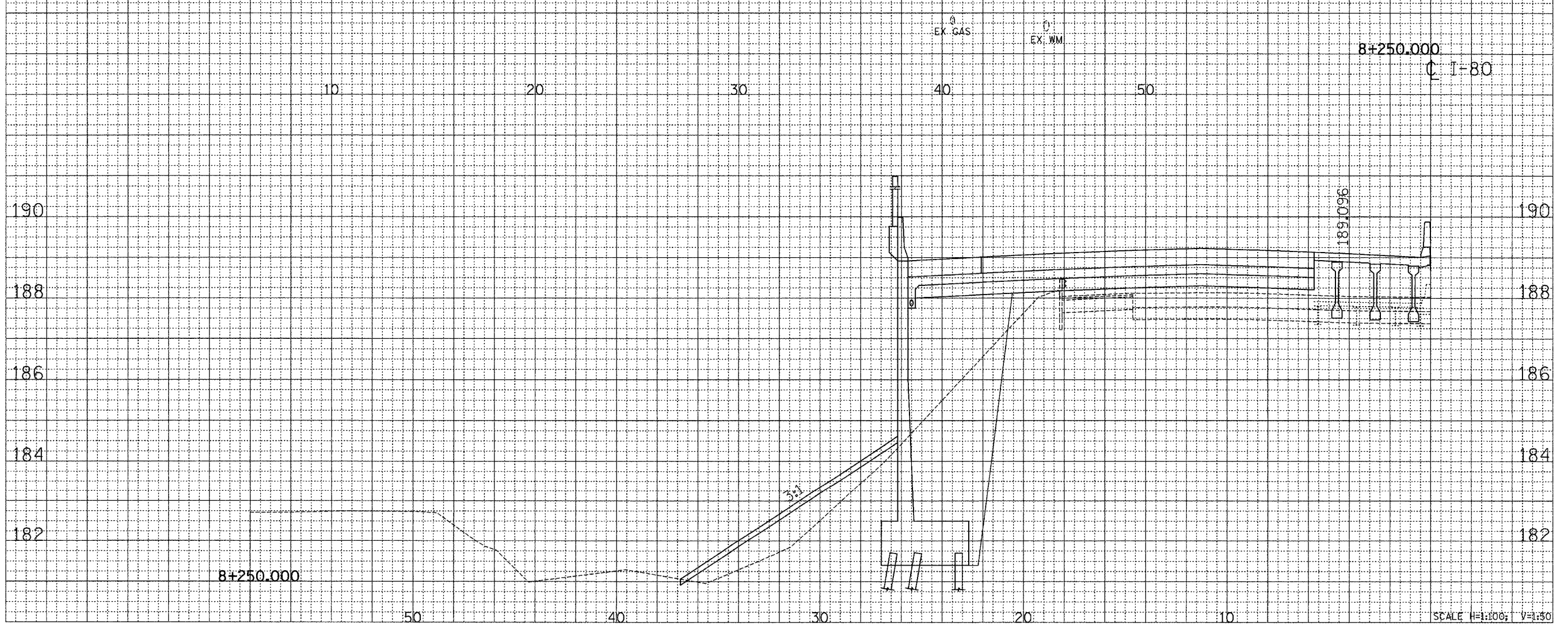

CROSS SECTION - I-80/94/US 6

... Sheets via BDC114 r6b 06/14/2005 08:58:59 AM

F.A.I. RTE.	SECTION	COUNTY	TOTAL SHEETS	SHEET NO.
80/94	2626.2-R-2	COOK	1207	1142
STA.		TO STA.		
FED. ROAD DIST. NO.		ILLINOIS	FED. AID PROJECT	
CONTRACT NO. 62114		INDOT DES. NO. 0100987		

FINAL SURVEY	DATE
SURVEYED	BY
NOTE BOOK	
NO.	
AREAS CHECKED	

ORIGINAL SURVEY	DATE
SURVEYED	BY
NOTE BOOK	
NO.	
AREAS CHECKED	

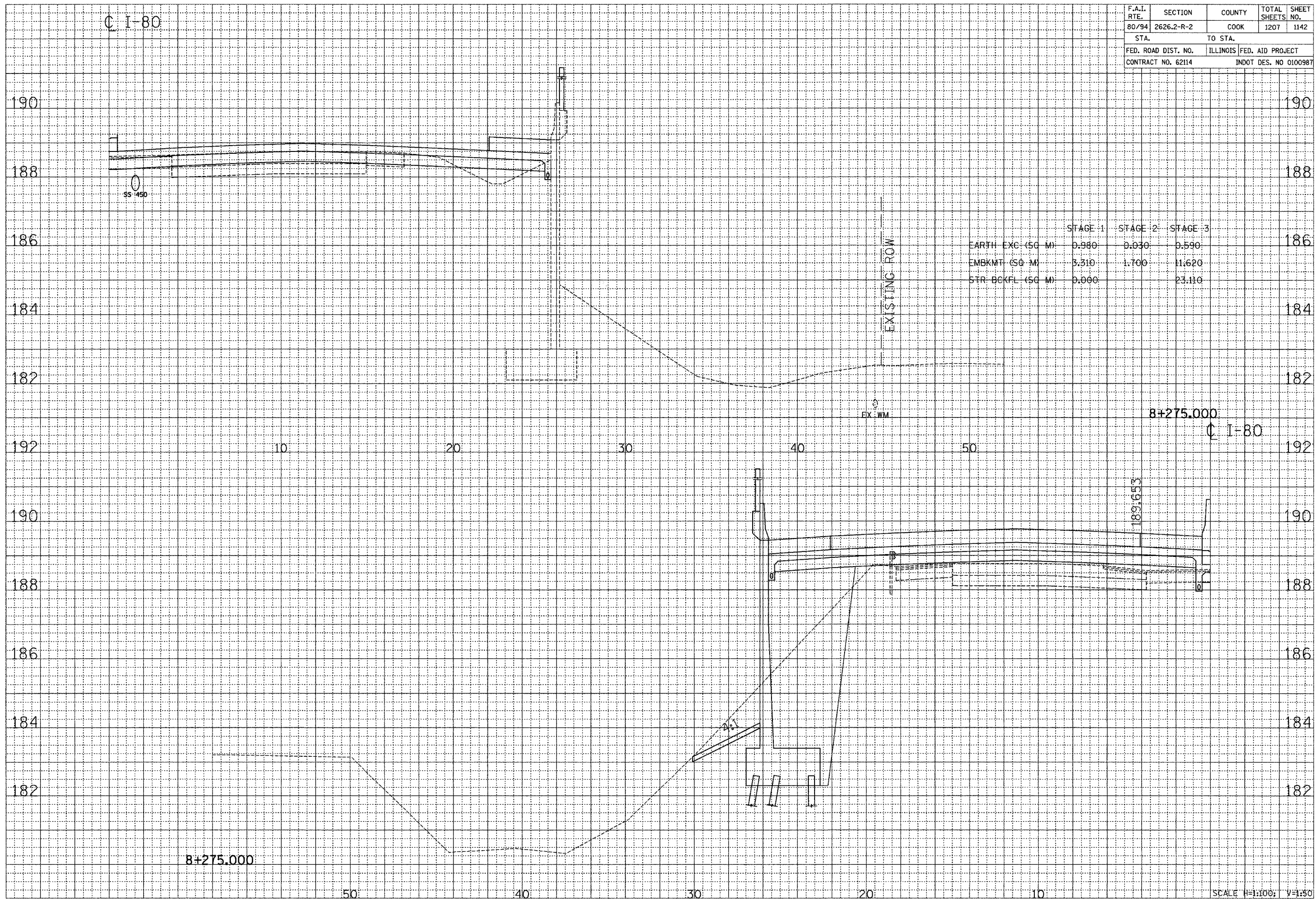

CROSS SECTION - I-80/94/US 6

...:\SHEETS\8150013.ras 06/11/2005 11:48:03 AM

F.A.I. RTE.	SECTION	COUNTY	TOTAL SHEETS	SHEET NO.
80/94	2626.2-R-2	COOK	1207	1143
STA.		TO STA.		
FED. ROAD DIST. NO.		ILLINOIS	FED. AID PROJECT	
CONTRACT NO. 62114		INDOT DES. NO 0100987		

FINAL SURVEY NO.	DATE
BLANKED SURVEY NO.	
PLOTTED SURVEY NO.	
REPLATE SURVEY NO.	
AREAS CHECKED	

ORIGINAL SURVEY NO.	DATE
BLANKED SURVEY NO.	
PLOTTED SURVEY NO.	
REPLATE SURVEY NO.	
AREAS CHECKED	

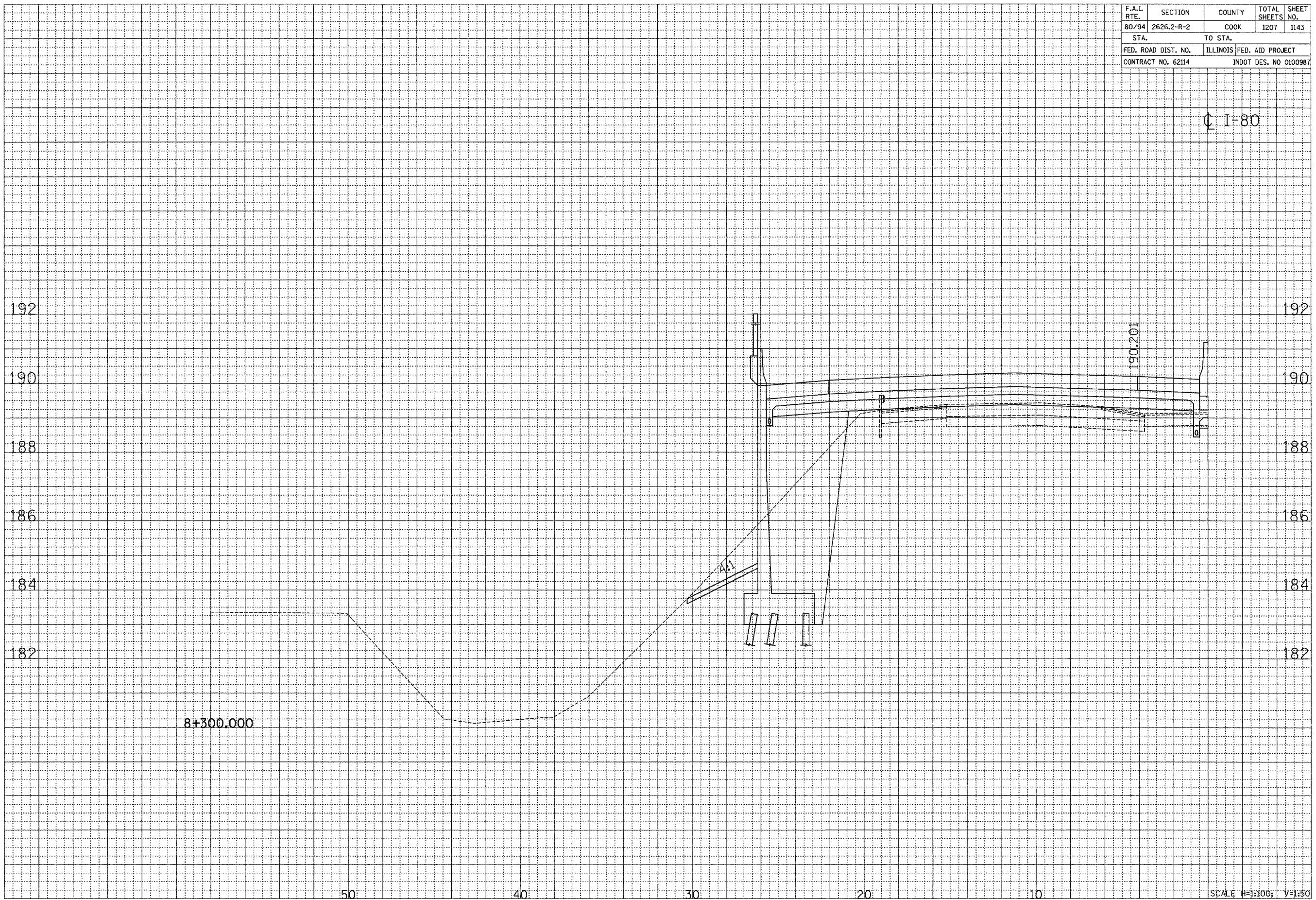

C. I-80

CROSS SECTION - I-80/94/US 6

SCALE H=1:100; V=1:50

F.A.I. RTE.	SECTION	COUNTY	TOTAL SHEETS	SHEET NO.
80/94	2626.2-R-2	COOK	1207	1144
STA.		TO STA.		
FED. ROAD DIST. NO.		ILLINOIS	FED. AID PROJECT	
CONTRACT NO. 62114		INDOT DES. NO 0100987		

C I-80

FINAL SURVEY	DATE
NO. _____	_____
BY _____	_____
DATE _____	_____
BY _____	_____
DATE _____	_____

ORIGINAL SURVEY	DATE
NO. _____	_____
BY _____	_____
DATE _____	_____
BY _____	_____
DATE _____	_____

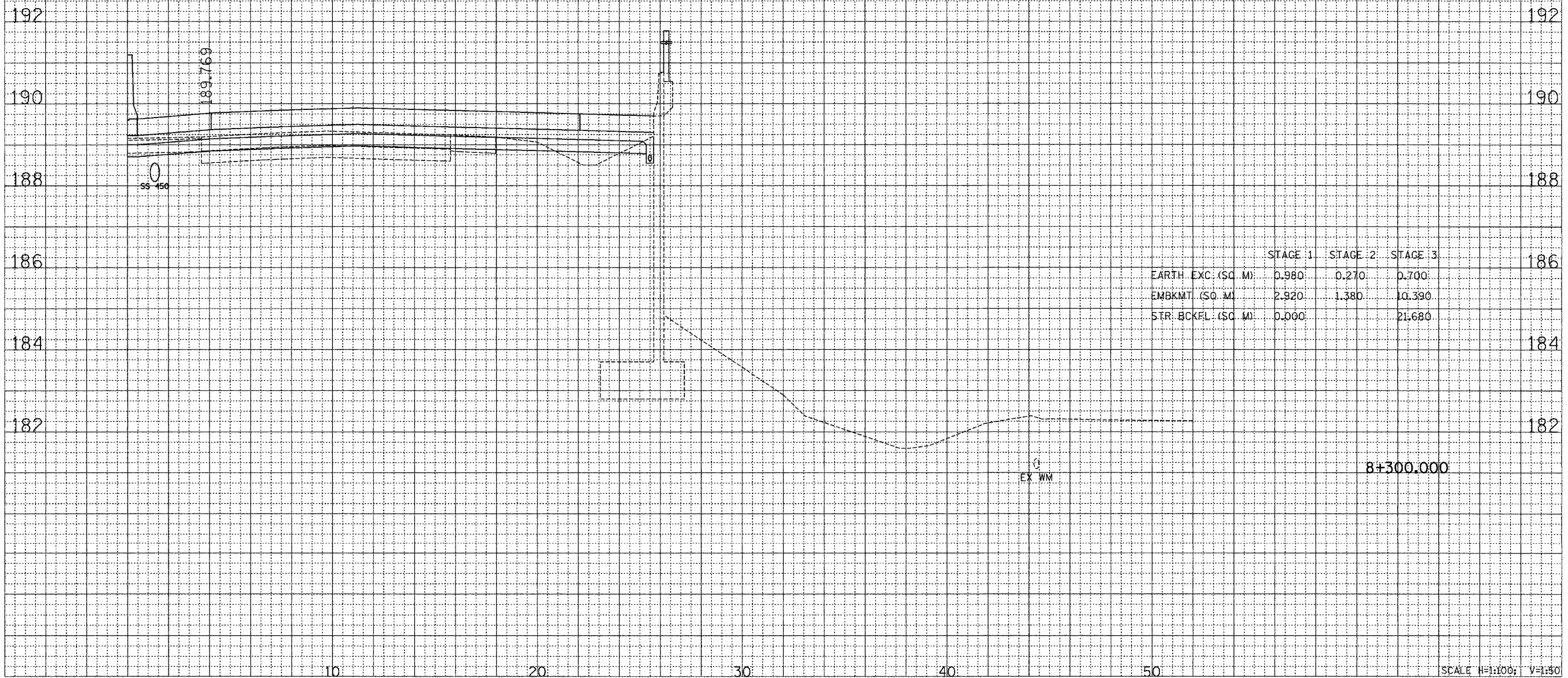

8+300.000

SCALE H=1:100; V=1:50

...:\Shen's\35001a.rps 08/17/2005 01:23:45 94

F.A.I. RTE.	SECTION	COUNTY	TOTAL SHEETS	SHEET NO.
80/94	2626.2-R-2	COOK	1207	1145
STA.		TO STA.		
FED. ROAD DIST. NO.		ILLINOIS	FED. AID PROJECT	
CONTRACT NO. 62114		INDOT DES. NO 0100987		

Q I-80

FINAL SURVEY	DATE	BY	DATE
NOTE BOOK NO.			
SURVEYED AREAS	TEMPLATE	AREAS	CHECKED

ORIGINAL SURVEY	DATE	BY	DATE
NOTE BOOK NO.			
SURVEYED AREAS	TEMPLATE	AREAS	CHECKED

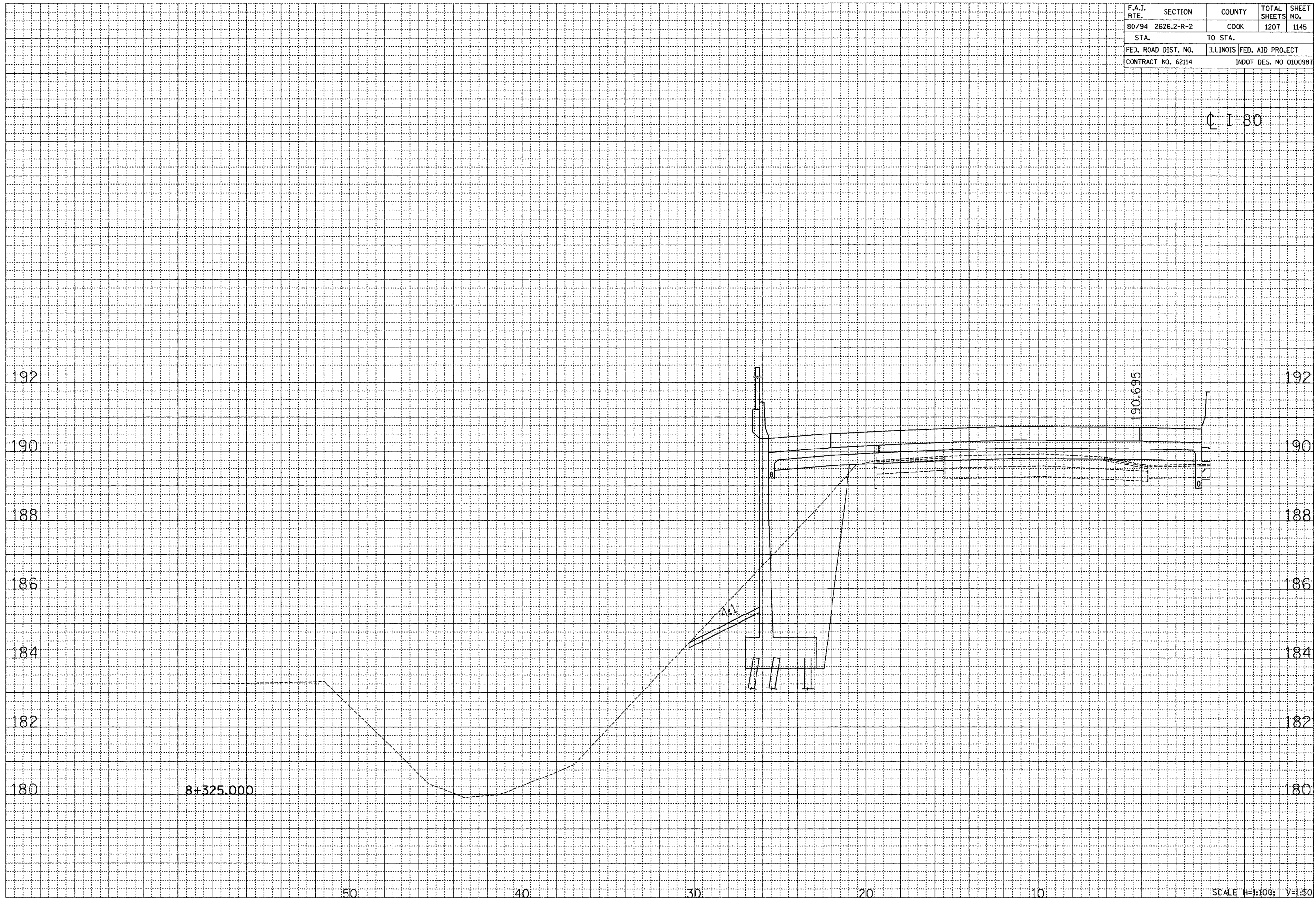

SCALE H=1:100; V=1:50

CROSS SECTION - I-80/94/US 6

F.A.I. RTE.	SECTION	COUNTY	TOTAL SHEETS	SHEET NO.
80/94	2626.2-R-2	COOK	1207	1146
STA.		TO STA.		
FED. ROAD DIST. NO.		ILLINOIS	FED. AID PROJECT	
CONTRACT NO. 62114		INDOT DES. NO 0100987		

C I-80

FINAL SURVEY	DATE
BLANKETED	BY
NOTE BOOK	
NO.	
AREAS CHECKED	

ORIGINAL SURVEY	DATE
BLANKETED	BY
NOTE BOOK	
NO.	
AREAS CHECKED	

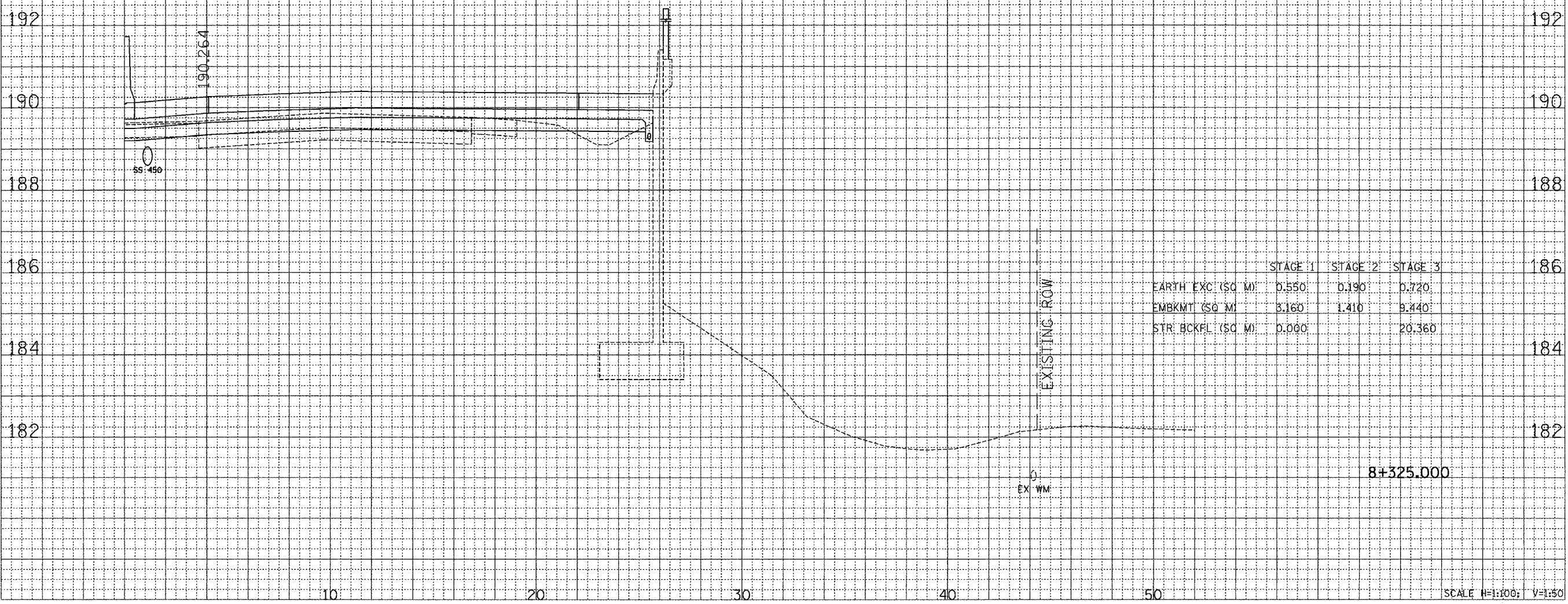

SCALE H=1:100; V=1:50

CROSS SECTION - I-80/94/US 6

...:\SHERIDAN\80921A.dwg 08/11/2006 01:23:44 PM

F.A.I. RTE.	SECTION	COUNTY	TOTAL SHEETS	SHEET NO.
80/94	2626.2-R-2	COOK	1207	1147
STA.		TO STA.		
FED. ROAD DIST. NO.		ILLINOIS	FED. AID PROJECT	
CONTRACT NO. 62114		INDOT DES. NO 0100987		

C I-80

FINAL SURVEY	SURVEYED	BY	DATE
NOTE BOOK NO.	PLOTTED		
	DATE		
	AREAS		
	CHECKED		

ORIGINAL SURVEY	SURVEYED	BY	DATE
NOTE BOOK NO.	PLOTTED		
	DATE		
	AREAS		
	CHECKED		

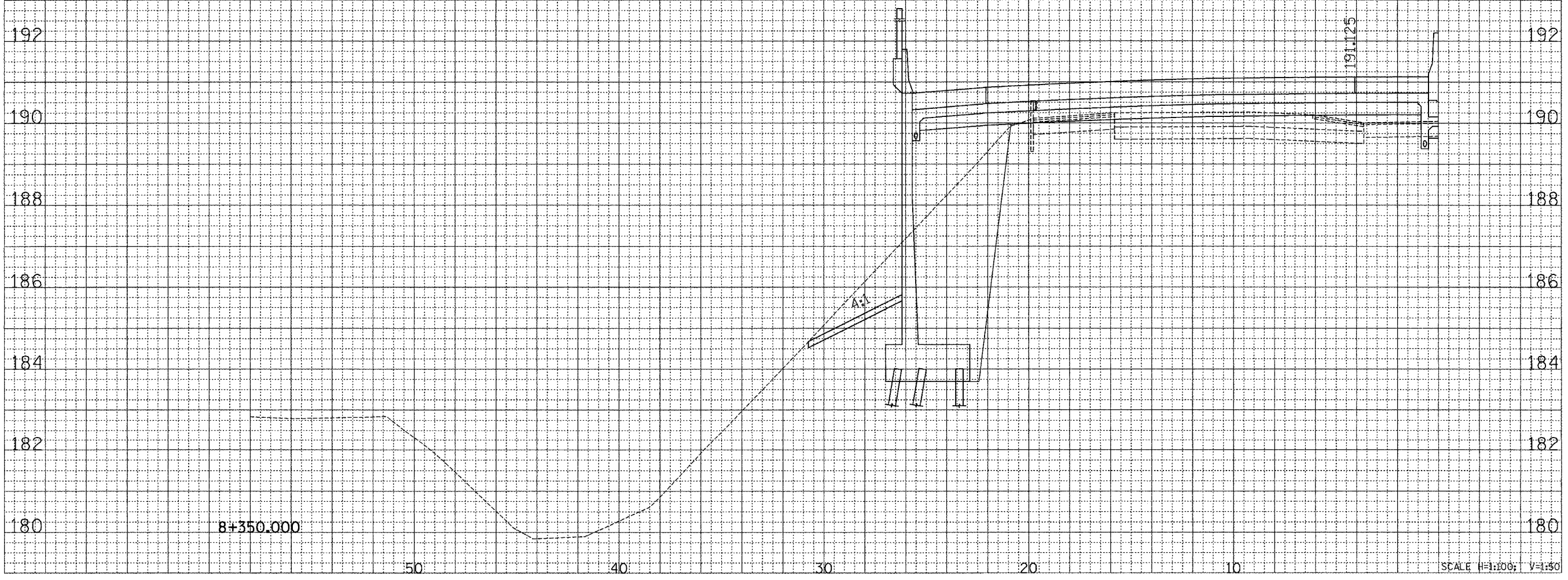

CROSS SECTION - I-80/94/US 6

F.A.I. RTE.	SECTION	COUNTY	TOTAL SHEETS	SHEET NO.
80/94	2626.2-R-2	COOK	1207	1148
STA.		TO STA.		
FED. ROAD DIST. NO.		ILLINOIS FED. AID PROJECT		
CONTRACT NO. 62114		INDOT DES. NO 0100987		

C I-80

FINAL SURVEY	BY	DATE
REVIEWED		
PLOTTED		
NOTE BOOK		
AREAS		
CHECKED		
NO.		

ORIGINAL SURVEY	BY	DATE
REVIEWED		
PLOTTED		
NOTE BOOK		
AREAS		
CHECKED		
NO.		

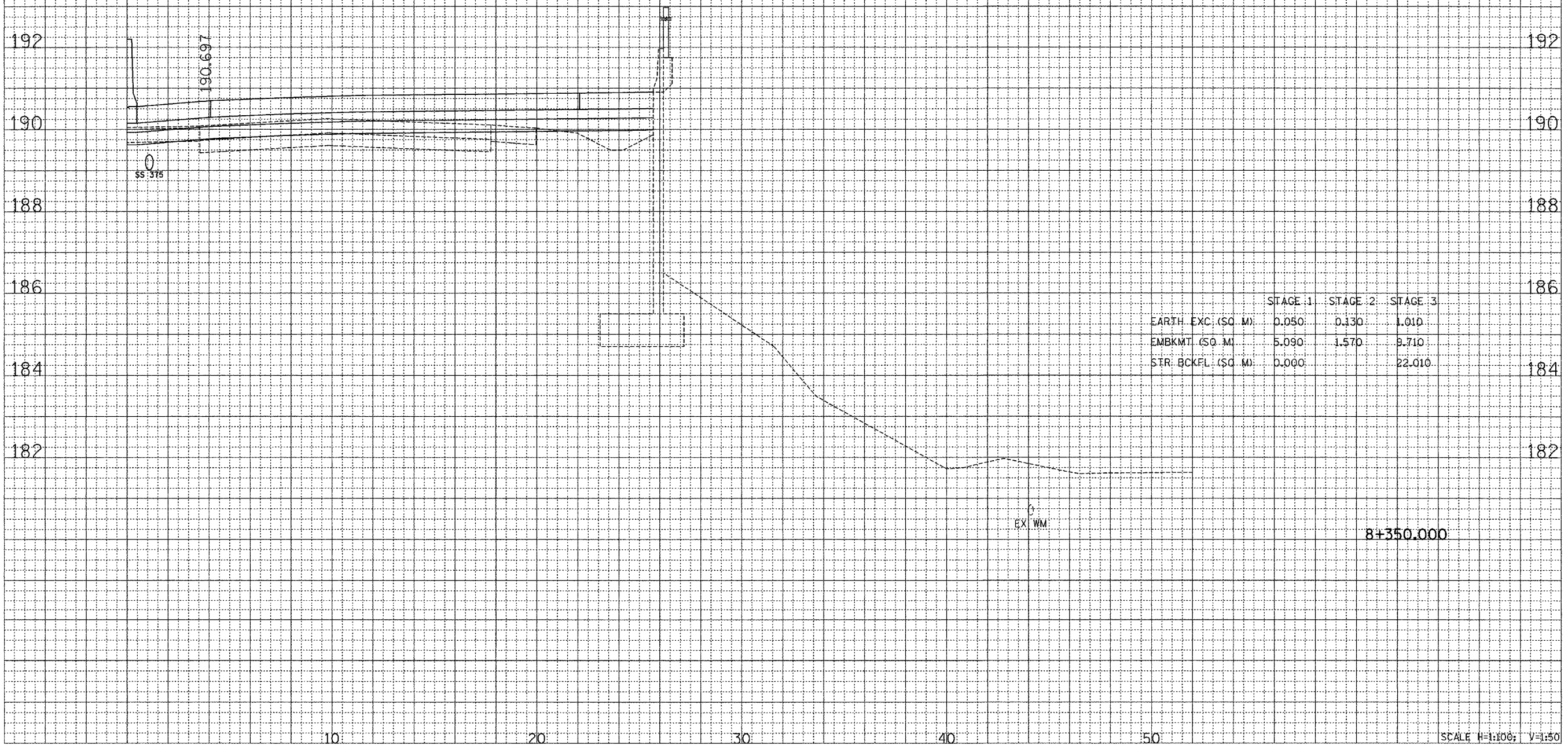

8+350.000

SCALE H=1:100; V=1:50

CROSS SECTION - I-80/94/US 6

...:\sheets\151602\ca_rds_00\17/2005 CI 23-45.dwg

F.A.I. RTE.	SECTION	COUNTY	TOTAL SHEETS	SHEET NO.
80/94	2626.2-R-2	COOK	1207	1149
STA.		TO STA.		
FED. ROAD DIST. NO.		ILLINOIS	FED. AID PROJECT	
CONTRACT NO. 62114		INDOT DES. NO 0100987		

C I-80

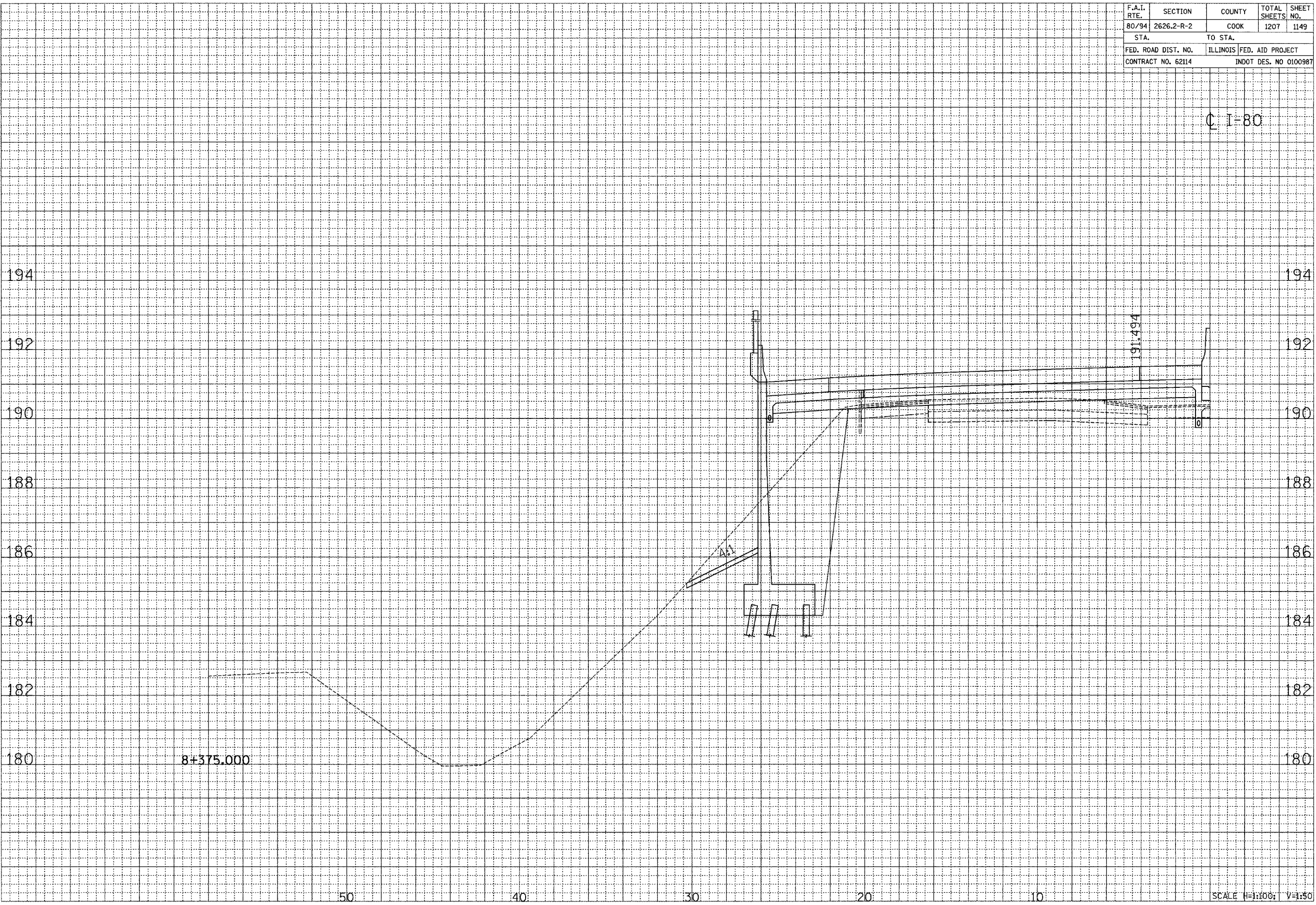

FINAL SURVEY	DATE
BY	
BLANKETED SURVEY	DATE
NOTE BOOK	
NO.	
TEMPLATE	
AREAS CHECKED	

ORIGINAL SURVEY	DATE
BY	
BLANKETED SURVEY	DATE
NOTE BOOK	
NO.	
TEMPLATE	
AREAS CHECKED	

SCALE H=1:100; V=1:50

CROSS SECTION - I-80/94/US 6

F.A.I. RTE.	SECTION	COUNTY	TOTAL SHEETS	SHEET NO.
80/94	2626.2-R-2	COOK	1207	1150
STA.		TO STA.		
FED. ROAD DIST. NO.		ILLINOIS	FED. AID PROJECT	
CONTRACT NO. 62114		INDOT DES. NO 0100987		

C I-80

FINAL SURVEY	BY	DATE
SHAWYED		
PLOTTED		
NOTE BOOK		
NO.		
AREAS CHECKED		

ORIGINAL SURVEY	BY	DATE
SHAWYED		
PLOTTED		
NOTE BOOK		
NO.		
AREAS CHECKED		

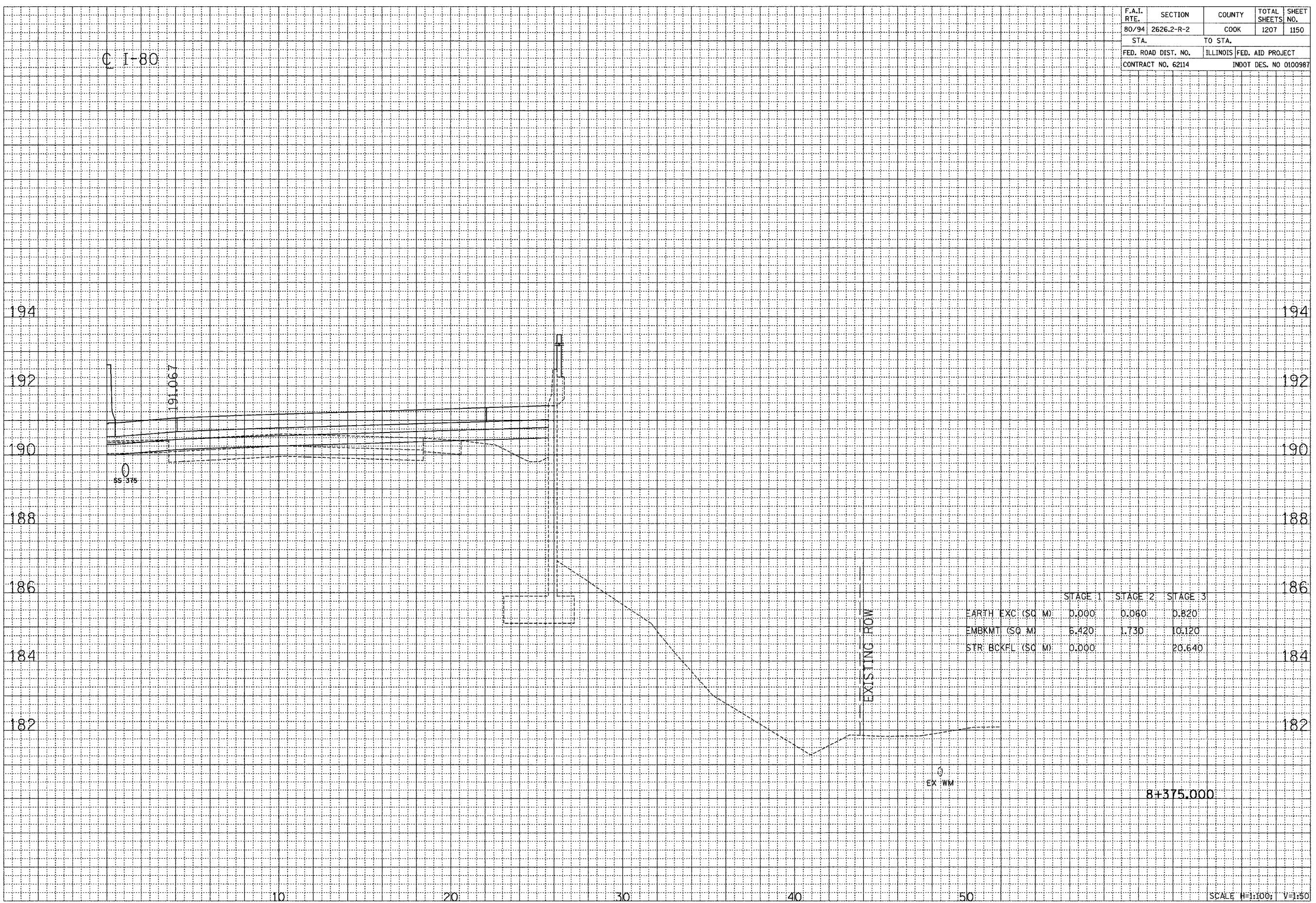

8+375.000

SCALE H=1:100; V=1:50

CROSS SECTION - I-80/94/US 6

\\spines\vs10021a.rds 06/12/2005 01:25:47 PM

F.A.I. RTE.	SECTION	COUNTY	TOTAL SHEETS	SHEET NO.
80/94	2626.2-R-2	COOK	1207	1151
STA.		TO STA.		
FED. ROAD DIST. NO.		ILLINOIS FED. AID PROJECT		
CONTRACT NO. 62114		INDOT DES. NO 0100987		

C I-80

ORIGINAL SURVEY	DATE
BY	
SHAWNTON PLOTTED	
NOTE BOOK NO.	
AREAS CHECKED	

ORIGINAL SURVEY	DATE
BY	
SHAWNTON PLOTTED	
NOTE BOOK NO.	
AREAS CHECKED	

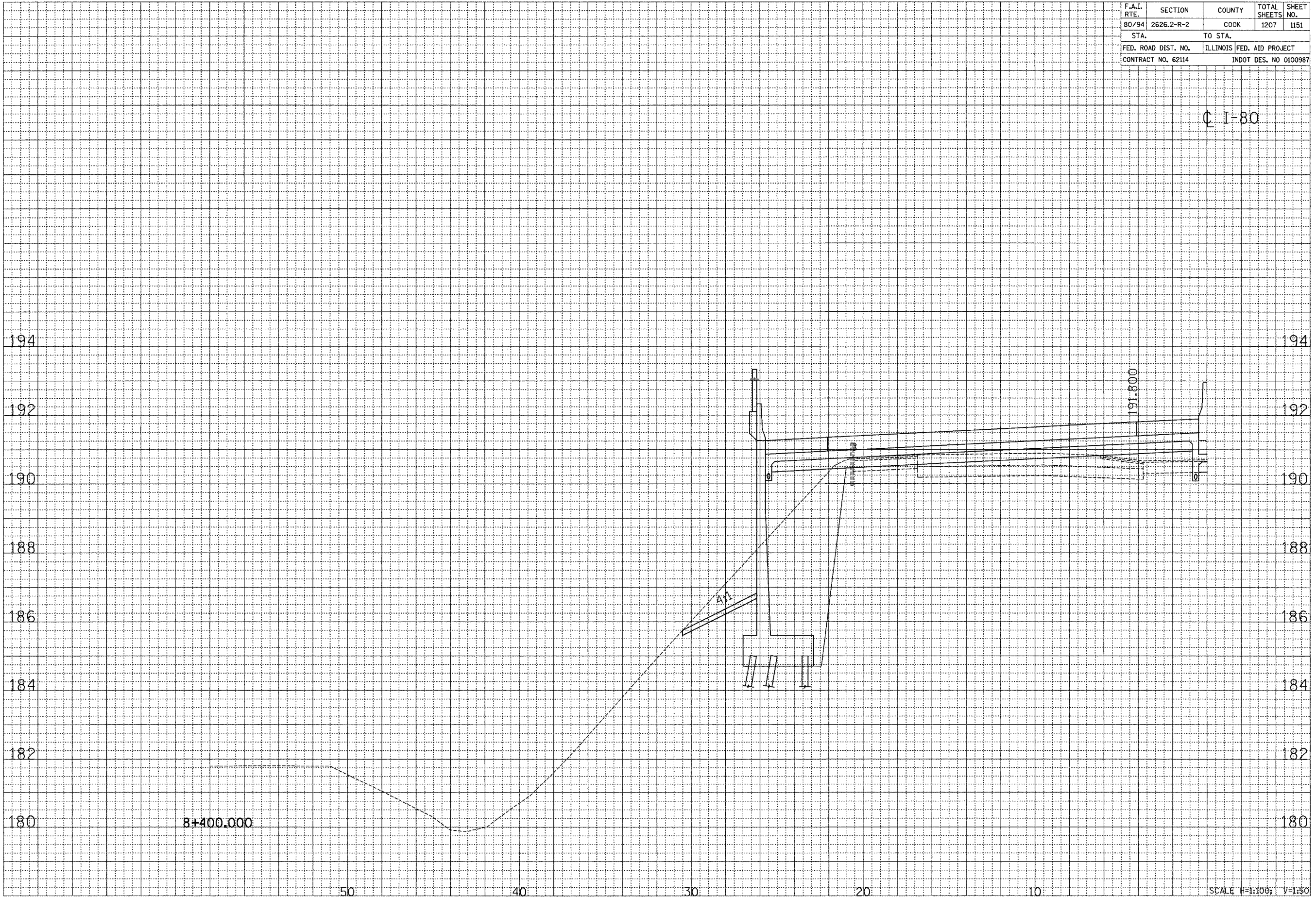

CROSS SECTION - I-80/94/US 6

SCALE H=1:100; V=1:50

F.A.L. RTE.	SECTION	COUNTY	TOTAL SHEETS	SHEET NO.
80/94	2626.2-R-2	COOK	1207	1152
STA.		TO STA.		
FED. ROAD DIST. NO.		ILLINOIS	FED. AID PROJECT	
CONTRACT NO. 62114		INDOT DES. NO 0100987		

C I-80

FINAL SURVEY	BY	DATE
NO.		
SURVEYED		
NOTE BOOK		
TEMPLATE		
AREAS		
CHECKED		

ORIGINAL SURVEY	BY	DATE
NO.		
SURVEYED		
NOTE BOOK		
TEMPLATE		
AREAS		
CHECKED		

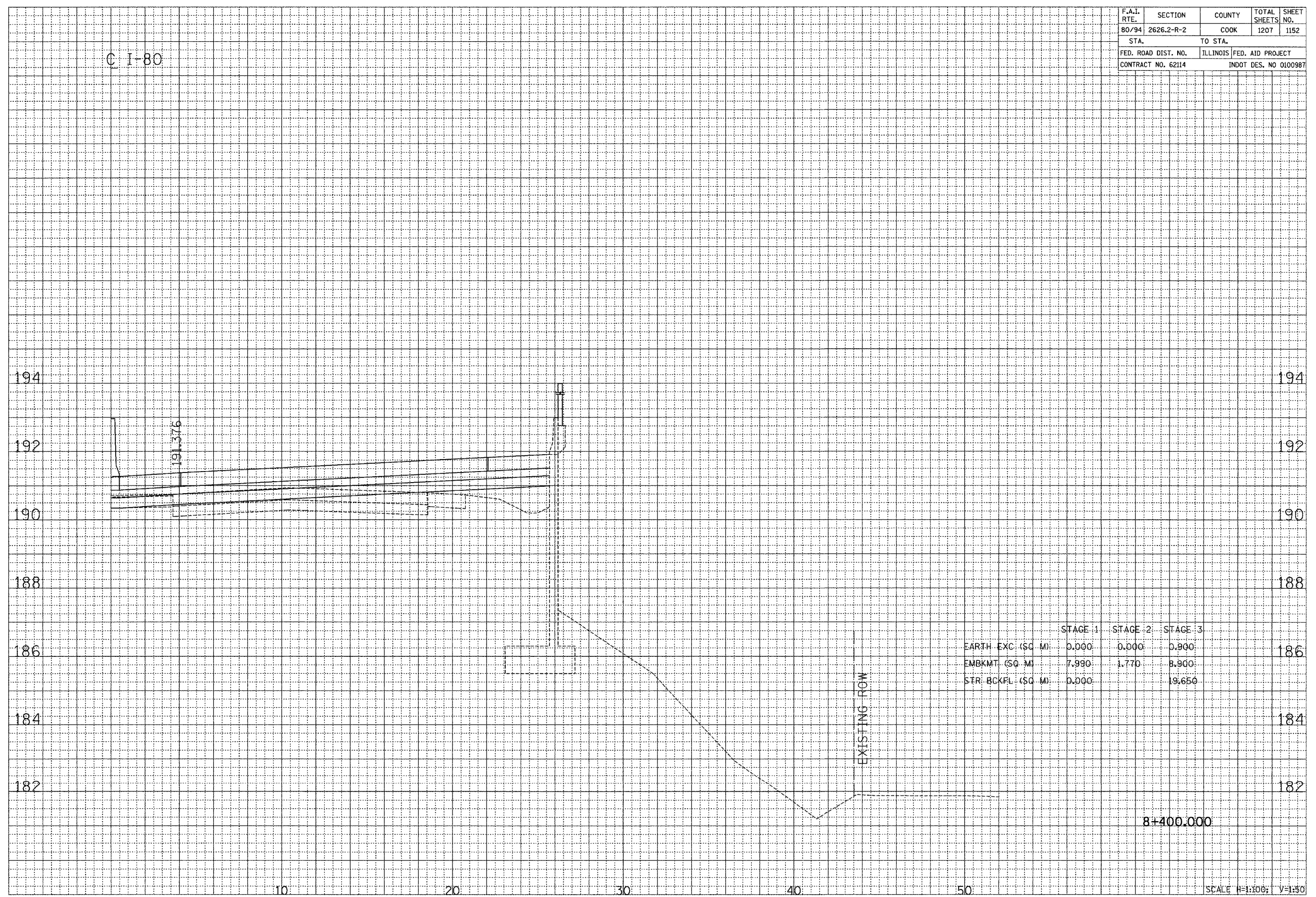

8+400.000

SCALE H=1:100; V=1:50

CROSS SECTION - I-80/94/US 6

F.A.I. RTE.	SECTION	COUNTY	TOTAL SHEETS	SHEET NO.
80/94	2626.2-R-2	COOK	1207	1153
STA.		TO STA.		
FED. ROAD DIST. NO.	ILLINOIS	FED. AID PROJECT		
CONTRACT NO. 62114	INDOT DES. NO 0100987			

FINAL SURVEY	DATE
NO.	
BY	
AREAS CHECKED	

ORIGINAL SURVEY	DATE
NO.	
BY	
AREAS CHECKED	

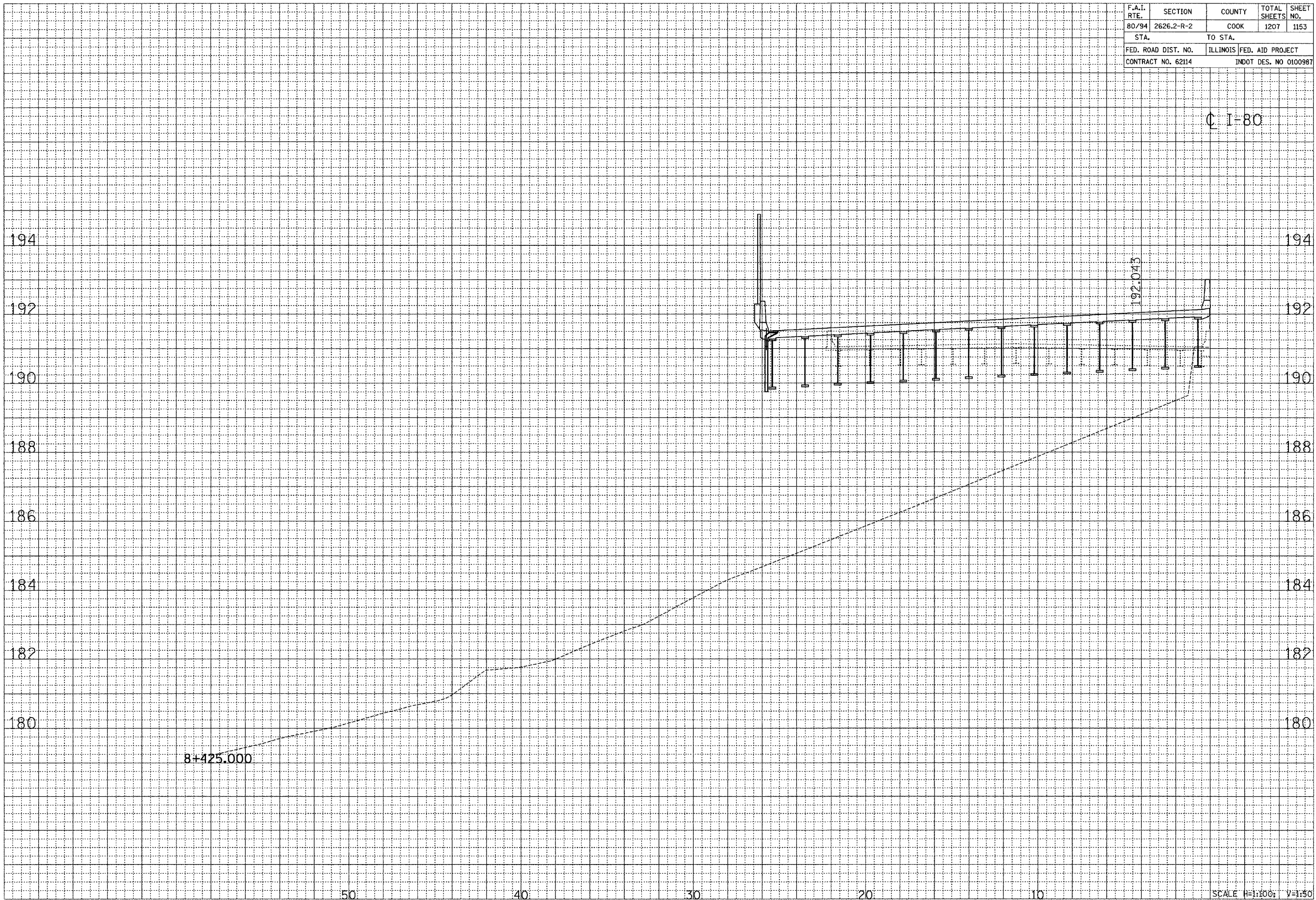

8+425.000

C I-80

192.043

SCALE H=1:100; V=1:50

CROSS SECTION - I-80/94/US 6

F.A.I. RTE.	SECTION	COUNTY	TOTAL SHEETS	SHEET NO.
80/94	2626.2-R-2	COOK	1207	1155
STA.		TO STA.		
FED. ROAD DIST. NO.		ILLINOIS FED. AID PROJECT		
CONTRACT NO. 62114		INDOT DES. NO 0100987		

BY	DATE
FINAL SURVEY	SURVEYED
NOTE BOOK	PLOTTED
NO.	AREAS
	CHECKED

BY	DATE
ORIGINAL SURVEY	SURVEYED
NOTE BOOK	PLOTTED
NO.	AREAS
	CHECKED

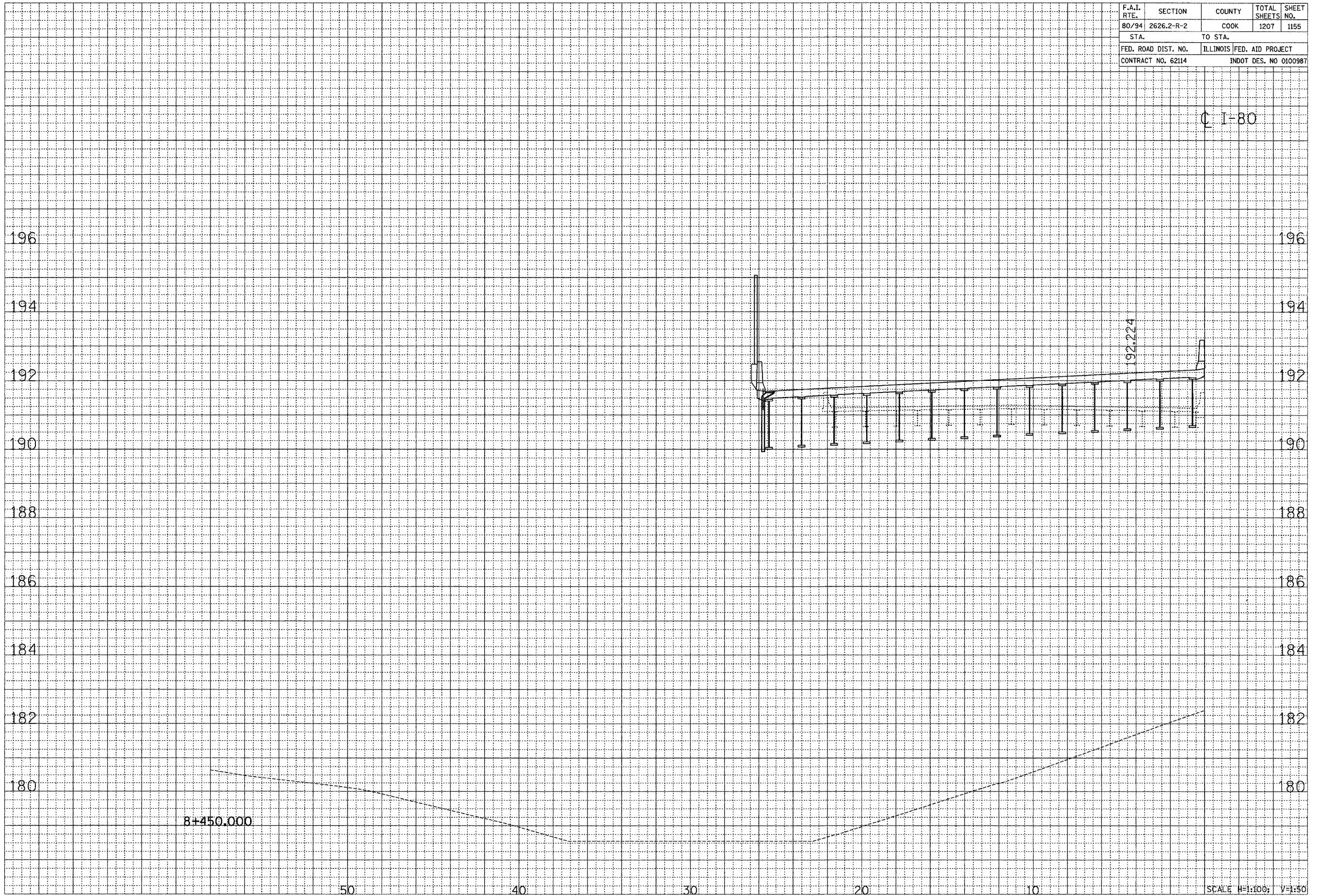

SCALE H=1:100; V=1:50

CROSS SECTION - I-80/94/US 6

...:liberts\vs160024.rvt 05/12/2005 09:00:20 AM

F.A.I. RTE.	SECTION	COUNTY	TOTAL SHEETS	SHEET NO.
80/94	2626.2-R-2	COOK	1207	1156
STA.		TO STA.		
FED. ROAD DIST. NO.		ILLINOIS FED. AID PROJECT		
CONTRACT NO. 62114		INDOT DES. NO 0100987		

C I-80

FINAL SURVEY	BY	DATE
NOTE BOOK NO.		
AREAS CHECKED		

ORIGINAL SURVEY	BY	DATE
NOTE BOOK NO.		
AREAS CHECKED		

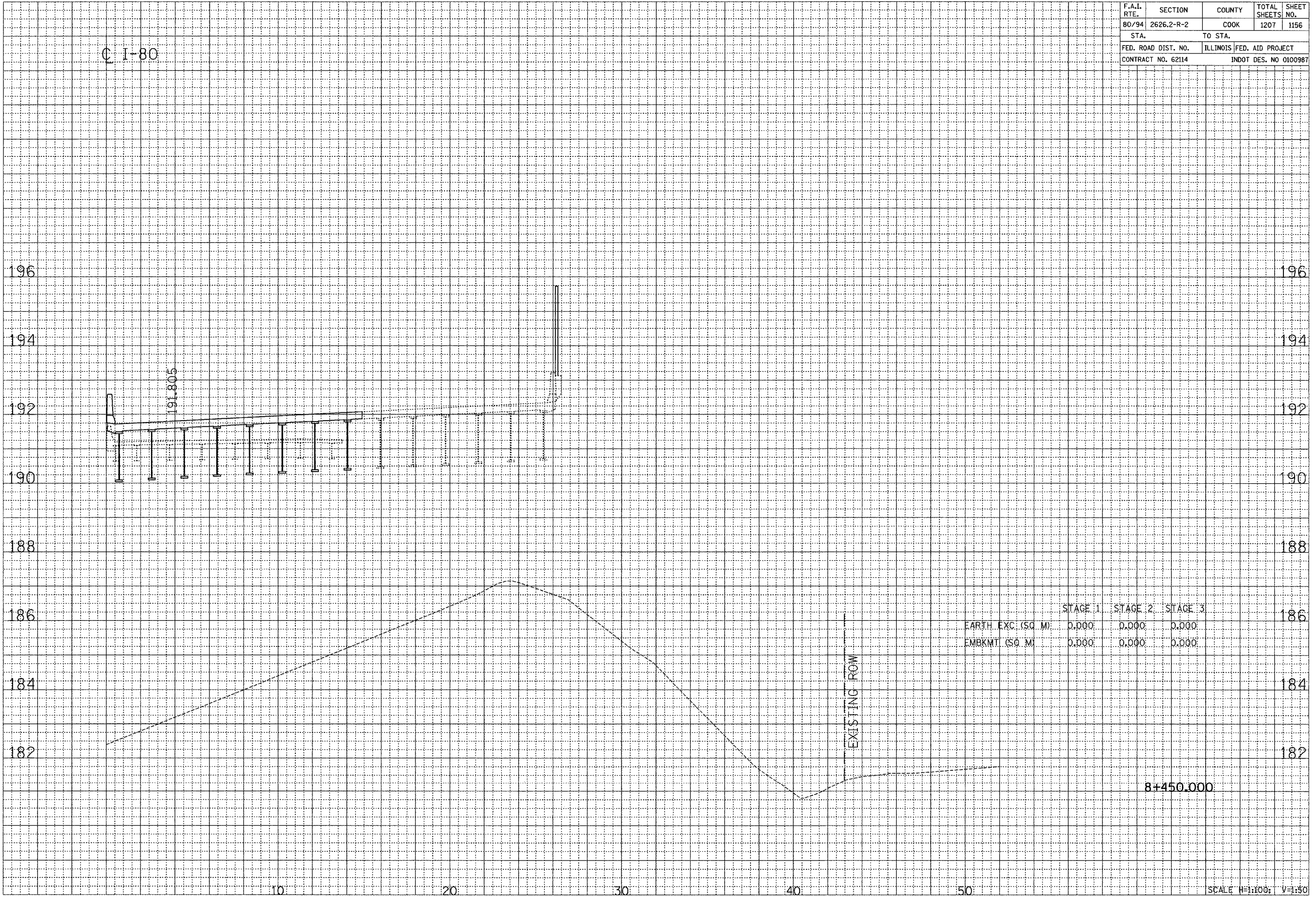

8+450.000

SCALE H=1:100; V=1:50

CROSS SECTION - I-80/94/US 6

F.A.I. RTE.	SECTION	COUNTY	TOTAL SHEETS	SHEET NO.
80/94	2626.2-R-2	COOK	1207	1157
STA.		TO STA.		
FED. ROAD DIST. NO.		ILLINOIS FED. AID PROJECT		
CONTRACT NO. 62114		INDOT DES. NO 0100987		

BY	DATE
ORIGINAL SURVEY	SURVEYED
NOTE BOOK NO.	PLOTTED
	AREAS
	CHECKED

BY	DATE
ORIGINAL SURVEY	SURVEYED
NOTE BOOK NO.	PLOTTED
	AREAS
	CHECKED

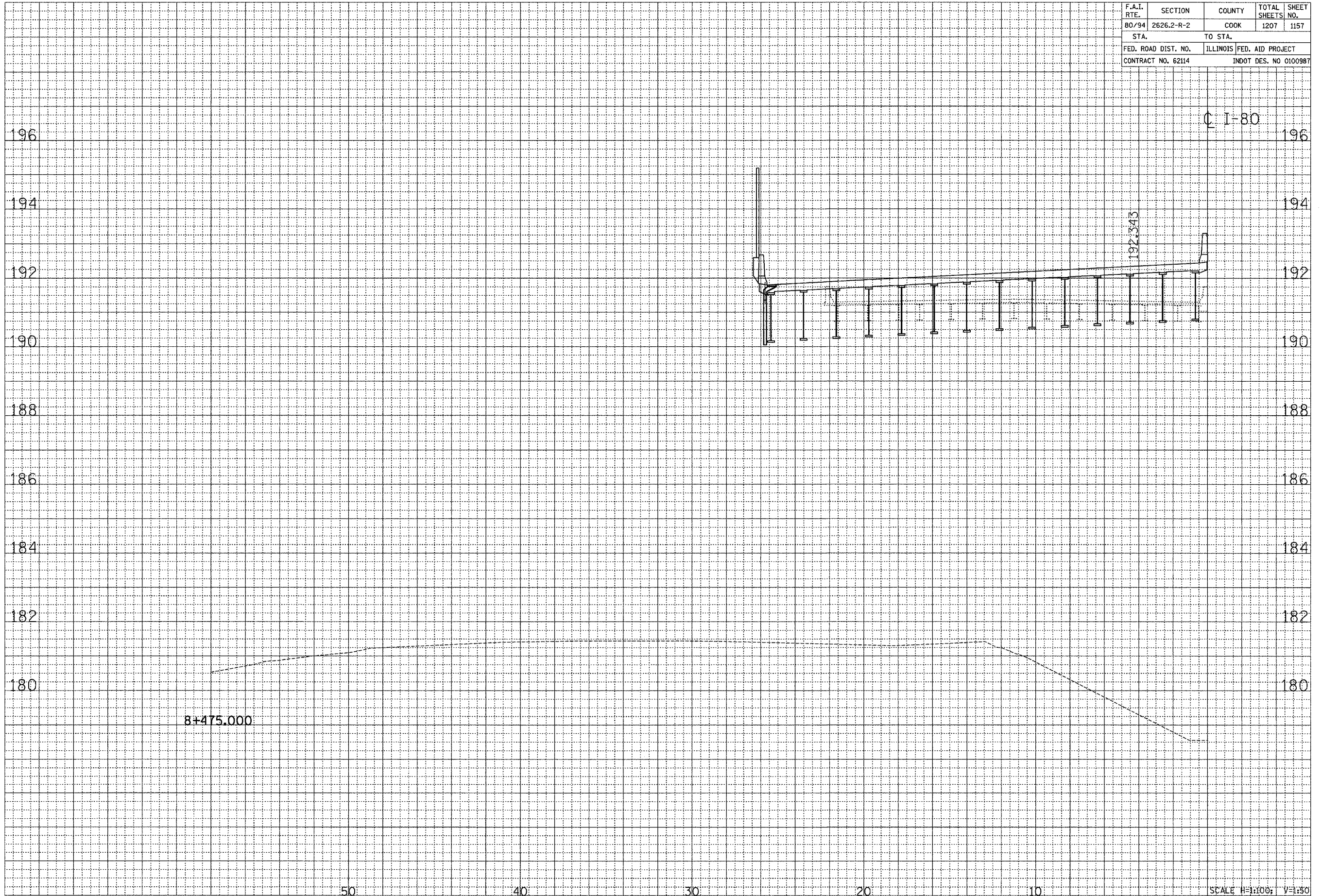

CROSS SECTION - I-80/94/US 6

0:00:00 09/17/2005 09:30:43 AM

F.A.I. RTE.	SECTION	COUNTY	TOTAL SHEETS	SHEET NO.
80/94	2626.2-R-2	COOK	1207	1158
STA.		TO STA.		
FED. ROAD DIST. NO.		ILLINOIS	FED. AID PROJECT	
CONTRACT NO. 62114		INDOT DES. NO 0100987		

C I-80

FINAL SURVEY	BY	DATE
NO. _____	_____	_____
NOTE BOOK NO.		
AREAS CHECKED		

ORIGINAL SURVEY	BY	DATE
NO. _____	_____	_____
NOTE BOOK NO.		
AREAS CHECKED		

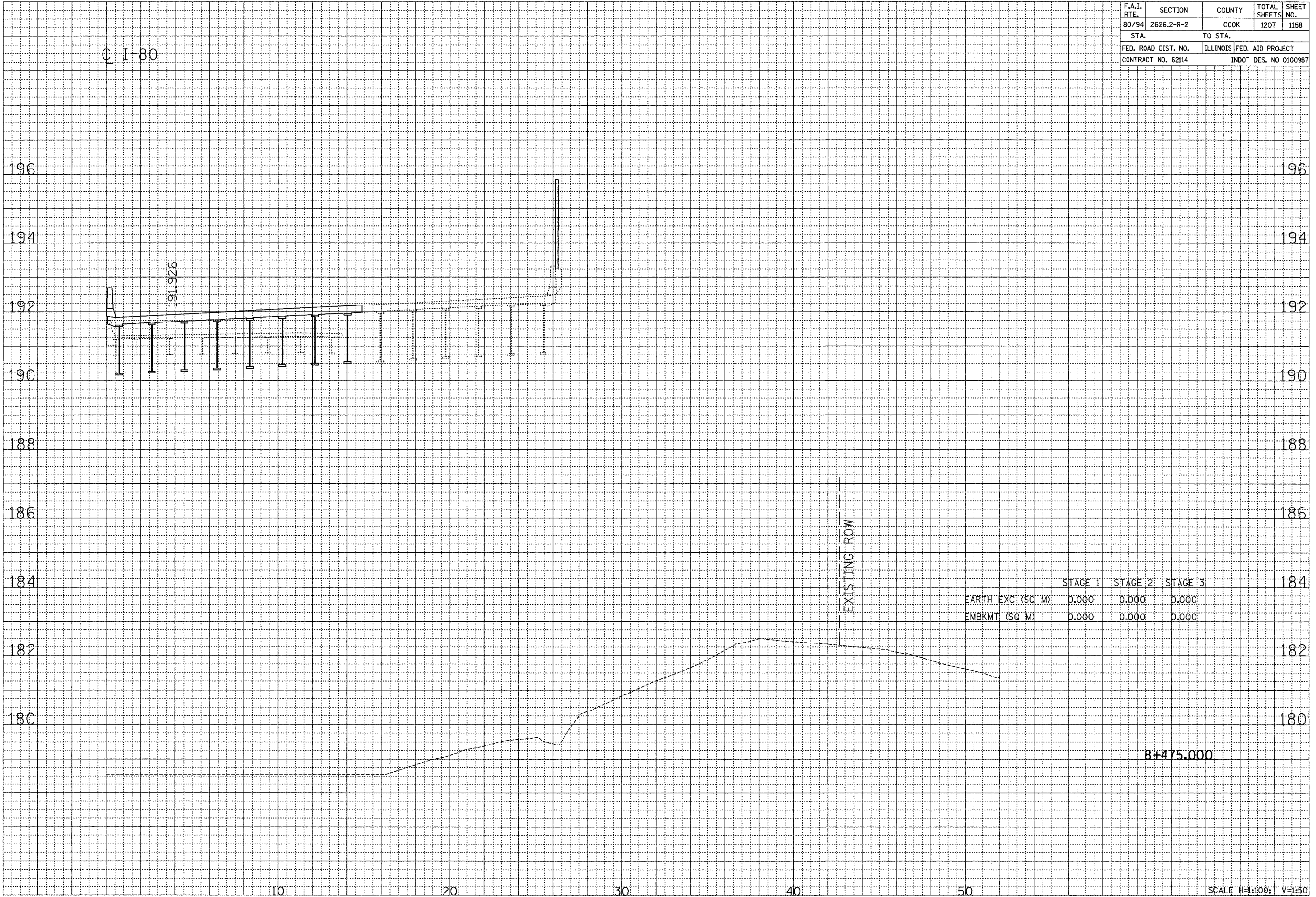

8+475.000

SCALE H=1:100; V=1:50

CROSS SECTION - I-80/94/US 6

F.A.I. RTE.	SECTION	COUNTY	TOTAL SHEETS	SHEET NO.
80/94	2626.2-R-2	COOK	1207	1159
STA.		TO STA.		
FED. ROAD DIST. NO.		ILLINOIS FED. AID PROJECT		
CONTRACT NO. 62114		INDOT DES. NO 0100987		

FINAL SURVEY	DATE
NO. _____	_____
BY _____	_____
DATE _____	_____
SAVED SURVEY	DATE
NO. _____	_____
BY _____	_____
DATE _____	_____
SAVED SURVEY	DATE
NO. _____	_____
BY _____	_____
DATE _____	_____

ORIGINAL SURVEY	DATE
NO. _____	_____
BY _____	_____
DATE _____	_____
SAVED SURVEY	DATE
NO. _____	_____
BY _____	_____
DATE _____	_____
SAVED SURVEY	DATE
NO. _____	_____
BY _____	_____
DATE _____	_____

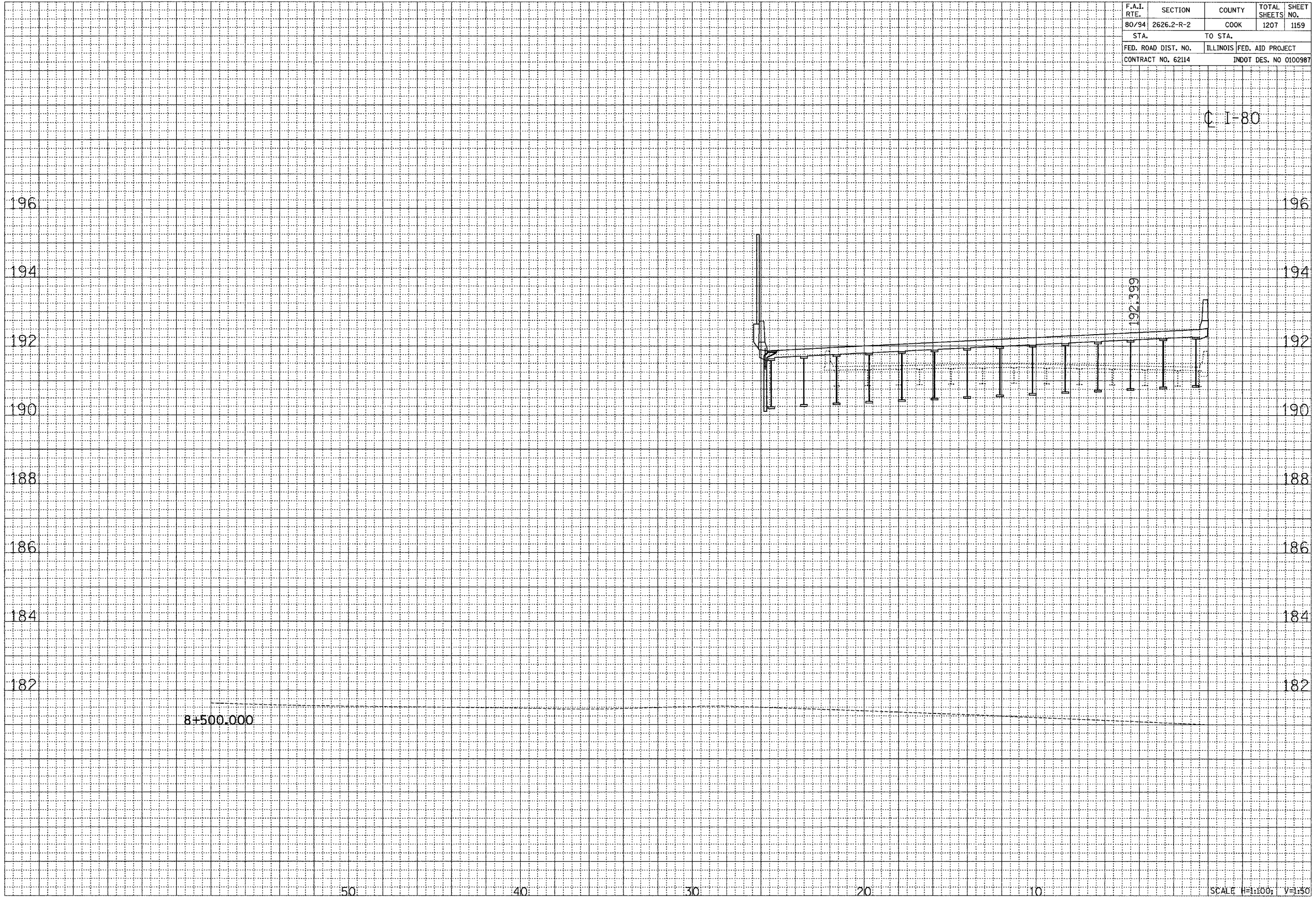

SCALE H=1:100; V=1:50

CROSS SECTION - I-80/94/US 6

F.A.I. RTE.	SECTION	COUNTY	TOTAL SHEETS	SHEET NO.
80/94	2626.2-R-2	COOK	1207	1160
STA.		TO STA.		
FED. ROAD DIST. NO.	ILLINOIS	FED. AID PROJECT		
CONTRACT NO. 62114	INDOT DES. NO 0100987			

C I-80

DATE	BY	DATE
SAVED SURVEY		
NOTE BOOK		
NO.		
AREA		
HEREIN CHECKED		

DATE	BY	DATE
ORIGINAL SURVEY		
NOTE BOOK		
NO.		
AREA		
HEREIN CHECKED		

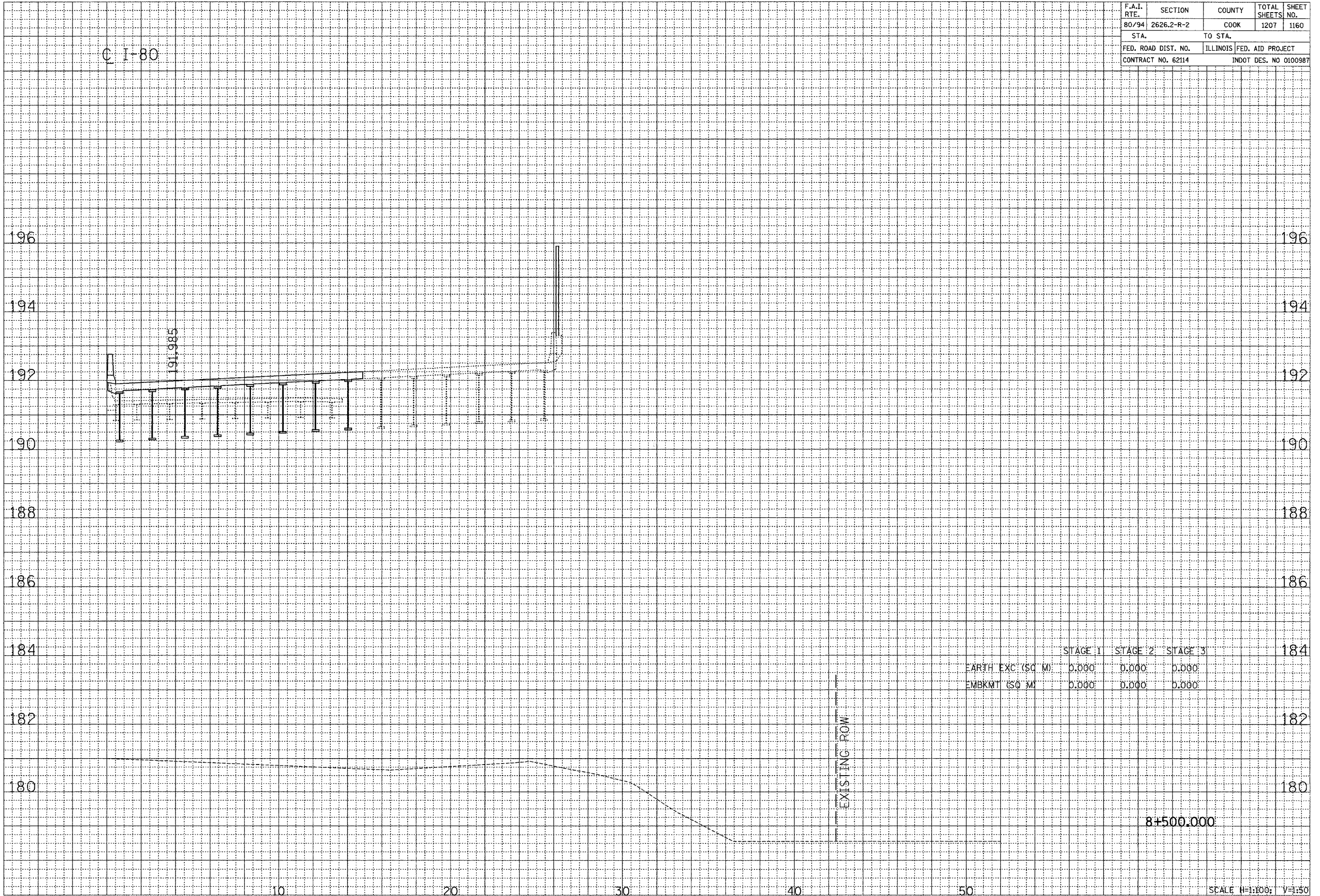

8+500.000

SCALE H=1:100; V=1:50

CROSS SECTION - I-80/94/US 6

F.A.I. RTE.	SECTION	COUNTY	TOTAL SHEETS	SHEET NO.
80/94	2626.2-R-2	COOK	1207	1161
STA.		TO STA.		
FED. ROAD DIST. NO.		ILLINOIS	FED. AID PROJECT	
CONTRACT NO. 62114		INDOT DES. NO 0100987		

FINAL SURVEY	DATE
NO. _____	_____
BY _____	_____
REVIEWED _____	_____
NOTE BOOK _____	_____
AREAS CHECKED _____	_____

ORIGINAL SURVEY	DATE
NO. _____	_____
BY _____	_____
REVIEWED _____	_____
NOTE BOOK _____	_____
AREAS CHECKED _____	_____

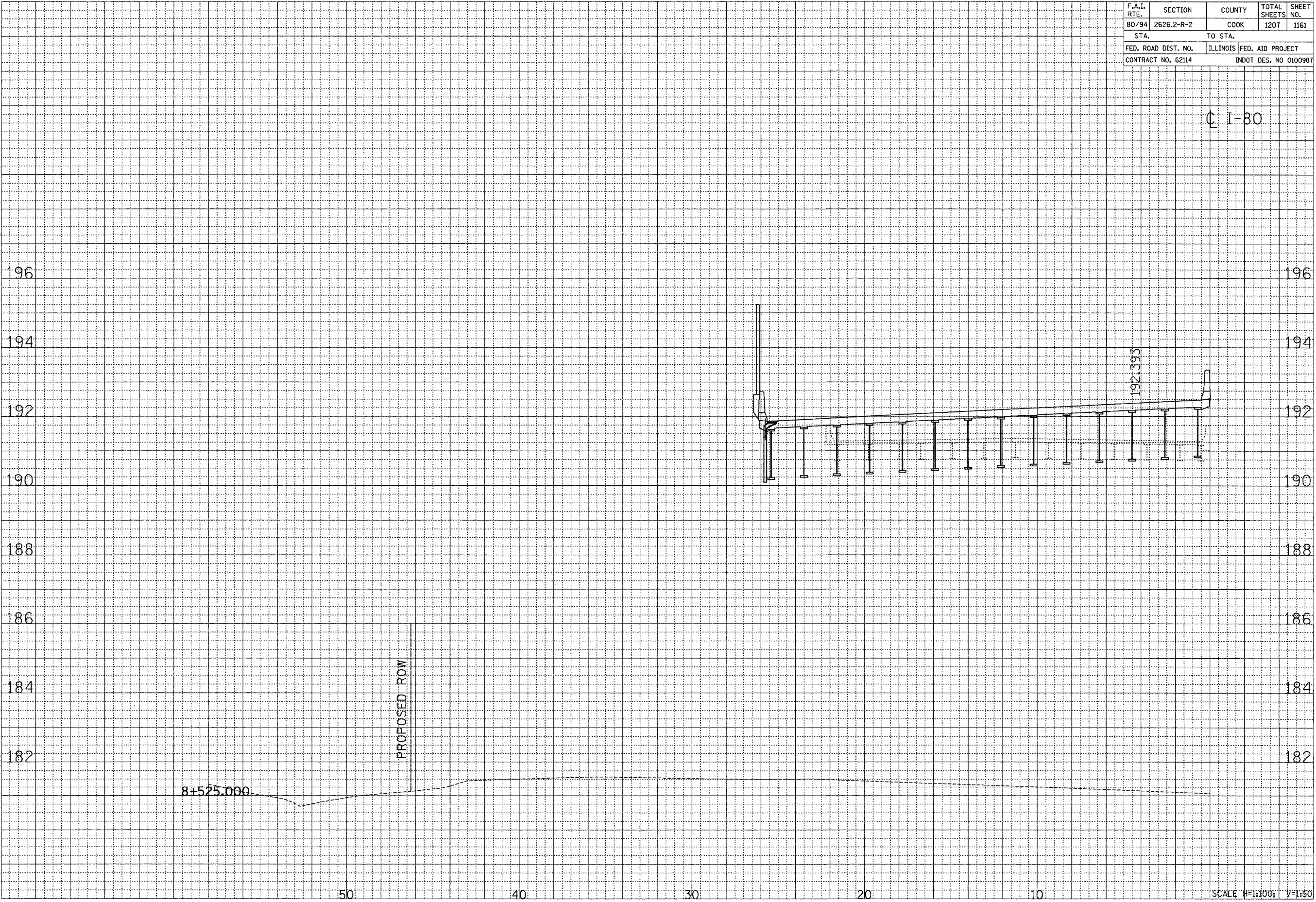

C I-80

SCALE H=1:100; V=1:50

CROSS SECTION - I-80/94/US 6

F.A.I. RTE.	SECTION	COUNTY	TOTAL SHEETS	SHEET NO.
80/94	2626.2-R-2	COOK	1207	1162
STA.		TO STA.		
FED. ROAD DIST. NO.		ILLINOIS	FED. AID PROJECT	
CONTRACT NO. 62114		INDOT DES. NO 0100987		

C I-80

FINAL SURVEY	SURVEYED	BY	DATE
NOTE BOOK NO.	PLOTTED		
	AREAS		
	CHECKED		

ORIGINAL SURVEY	SURVEYED	BY	DATE
NOTE BOOK NO.	PLOTTED		
	AREAS		
	CHECKED		

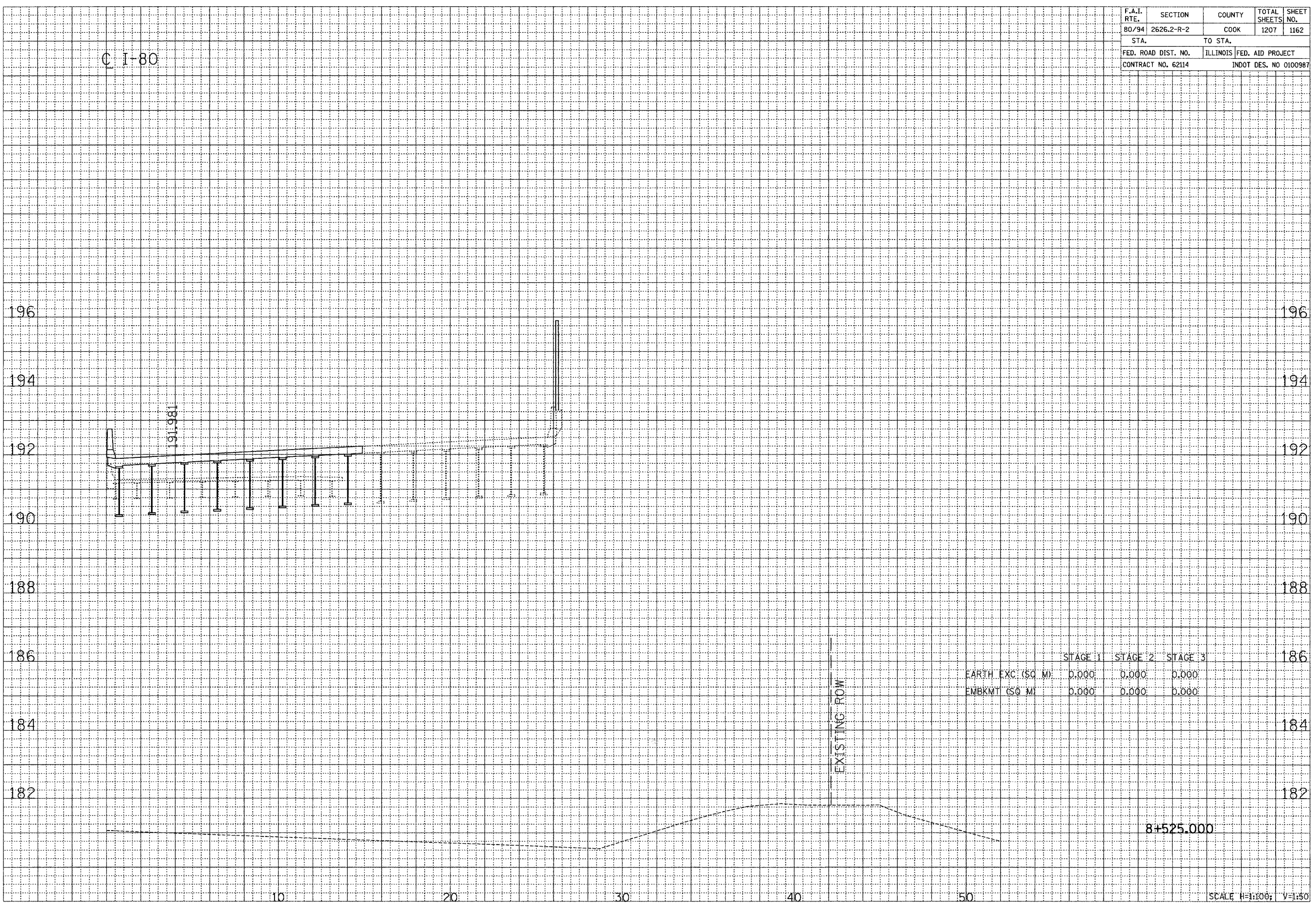

CROSS SECTION - I-80/94/US 6

Scale: H=1:100; V=1:50

F.A.I. RTE.	SECTION	COUNTY	TOTAL SHEETS	SHEET NO.
80/94	2626.2-R-2	COOK	1207	1163
STA.		TO STA.		
FED. ROAD DIST. NO.		ILLINOIS	FED. AID PROJECT	
CONTRACT NO. 62114		INDOT DES. NO 0100987		

FINAL SURVEY	BY	DATE
REVISIONS		
NO. _____		
DATE _____		
BY _____		
DATE _____		
BY _____		
DATE _____		

ORIGINAL SURVEY	BY	DATE
REVISIONS		
NO. _____		
DATE _____		
BY _____		
DATE _____		
BY _____		
DATE _____		

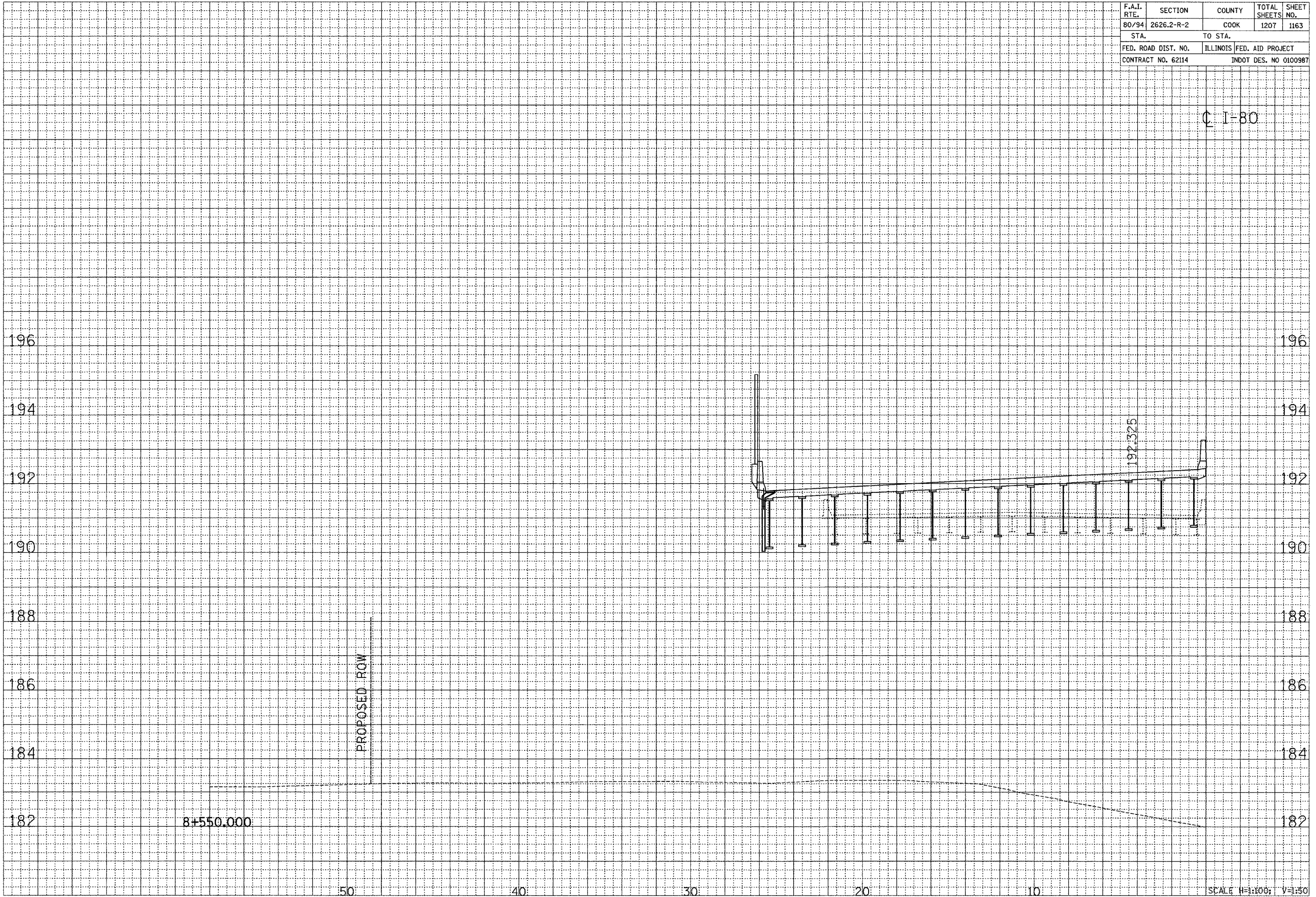

CL I-80

CROSS SECTION - I-80/94/US 6

SCALE H=1:100; V=1:50

F.A.I. RTE.	SECTION	COUNTY	TOTAL SHEETS	SHEET NO.
80/94	2626.2-R-2	COOK	1207	1164
STA.		TO STA.		
FED. ROAD DIST. NO.		ILLINOIS	FED. AID PROJECT	
CONTRACT NO. 62114		INDOT DES. NO 0100987		

C I-80

FINAL SURVEY	DATE
BY	
REVIEWED	
DATE	
NOTE BOOK	
NO.	
TEMPLATE	
AREAS CHECKED	

ORIGINAL SURVEY	DATE
BY	
REVIEWED	
DATE	
NOTE BOOK	
NO.	
TEMPLATE	
AREAS CHECKED	

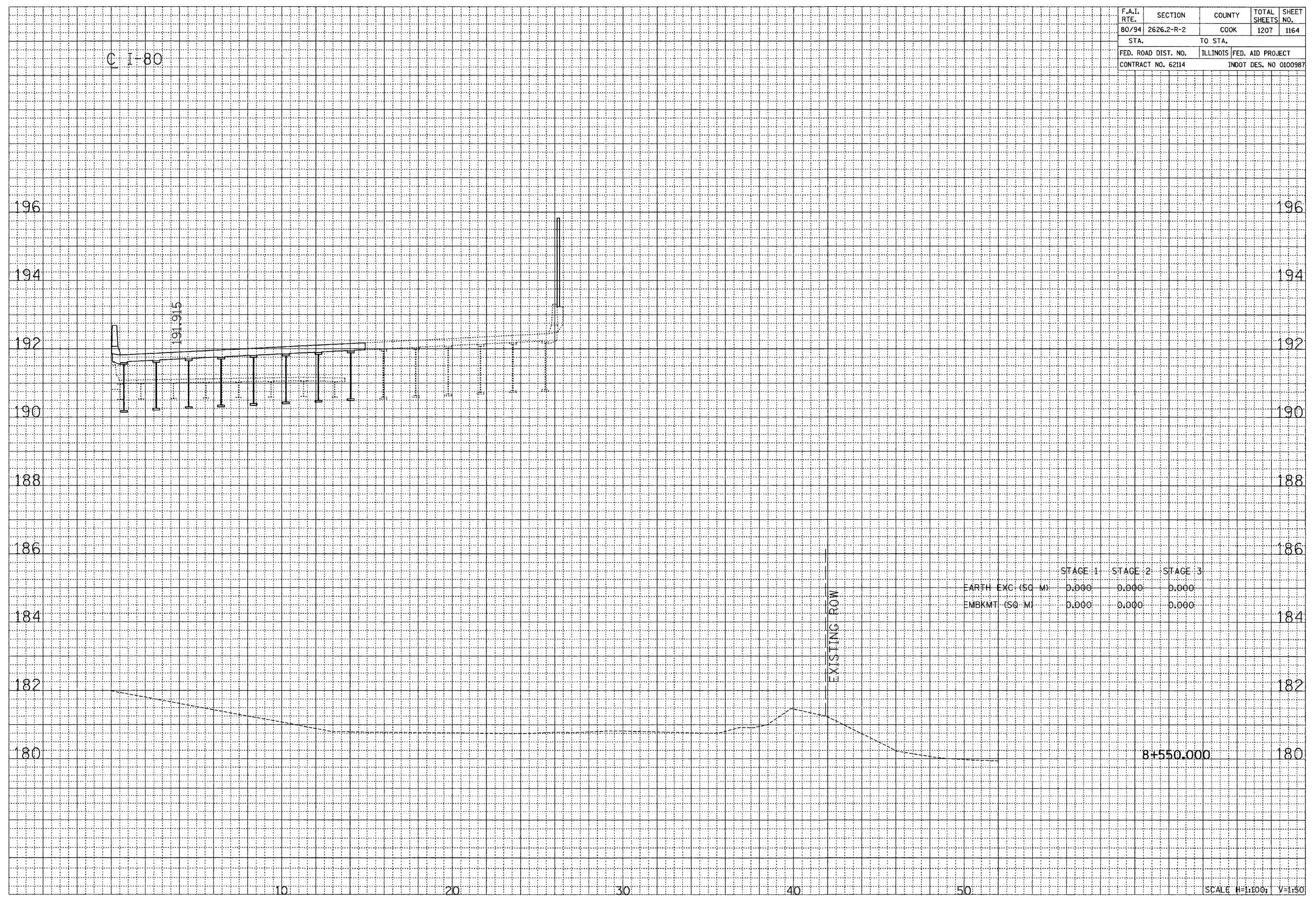

8+550.000

SCALE H=1:100; V=1:50

CROSS SECTION - I-80/94/US 6

F.A.I. RTE.	SECTION	COUNTY	TOTAL SHEETS	SHEET NO.
80/94	2626.2-R-2	COOK	1207	1165
STA.		TO STA.		
FED. ROAD DIST. NO.		ILLINOIS FED. AID PROJECT		
CONTRACT NO. 62114		INDOT DES. NO 0100987		

FINAL SURVEY	DATE
BY	
SURVEYED	
PLOTTED	
NOTE BOOK	
AREAS CHECKED	

ORIGINAL SURVEY	DATE
BY	
SURVEYED	
PLOTTED	
NOTE BOOK	
AREAS CHECKED	

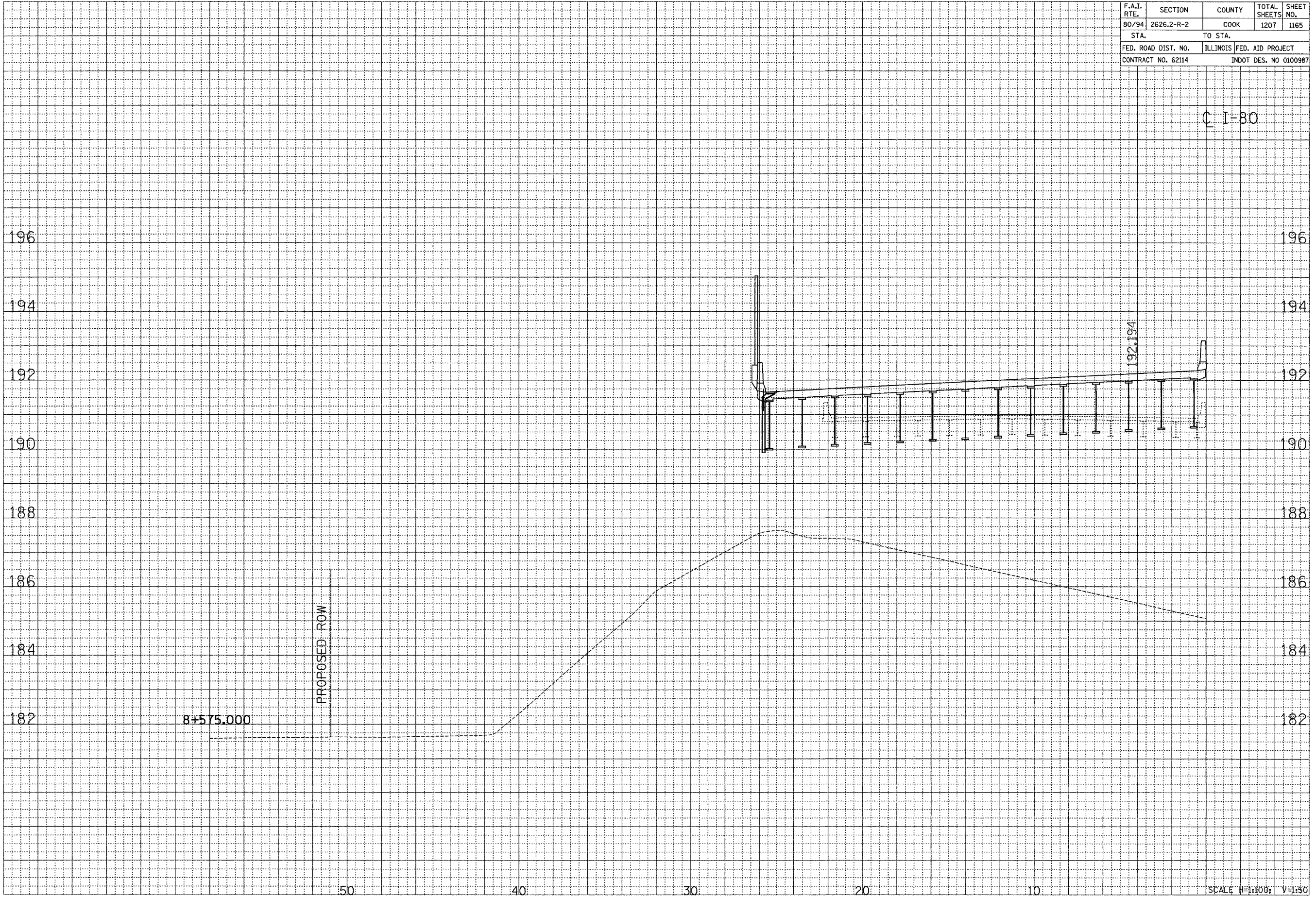

CROSS SECTION - I-80/94/US 6

SCALE H=1:100; V=1:50

F.A.I. RTE.	SECTION	COUNTY	TOTAL SHEETS	SHEET NO.
80/94	2626.2-R-2	COOK	1207	1166
STA.		TO STA.		
FED. ROAD DIST. NO.		ILLINOIS FED. AID PROJECT		
CONTRACT NO. 62114		INDOT DES. NO 0100987		

C I-80

FINAL SURVEY	BY	DATE
NOTE BOOK NO.		
AREAS CHECKED		

ORIGINAL SURVEY	BY	DATE
NOTE BOOK NO.		
AREAS CHECKED		

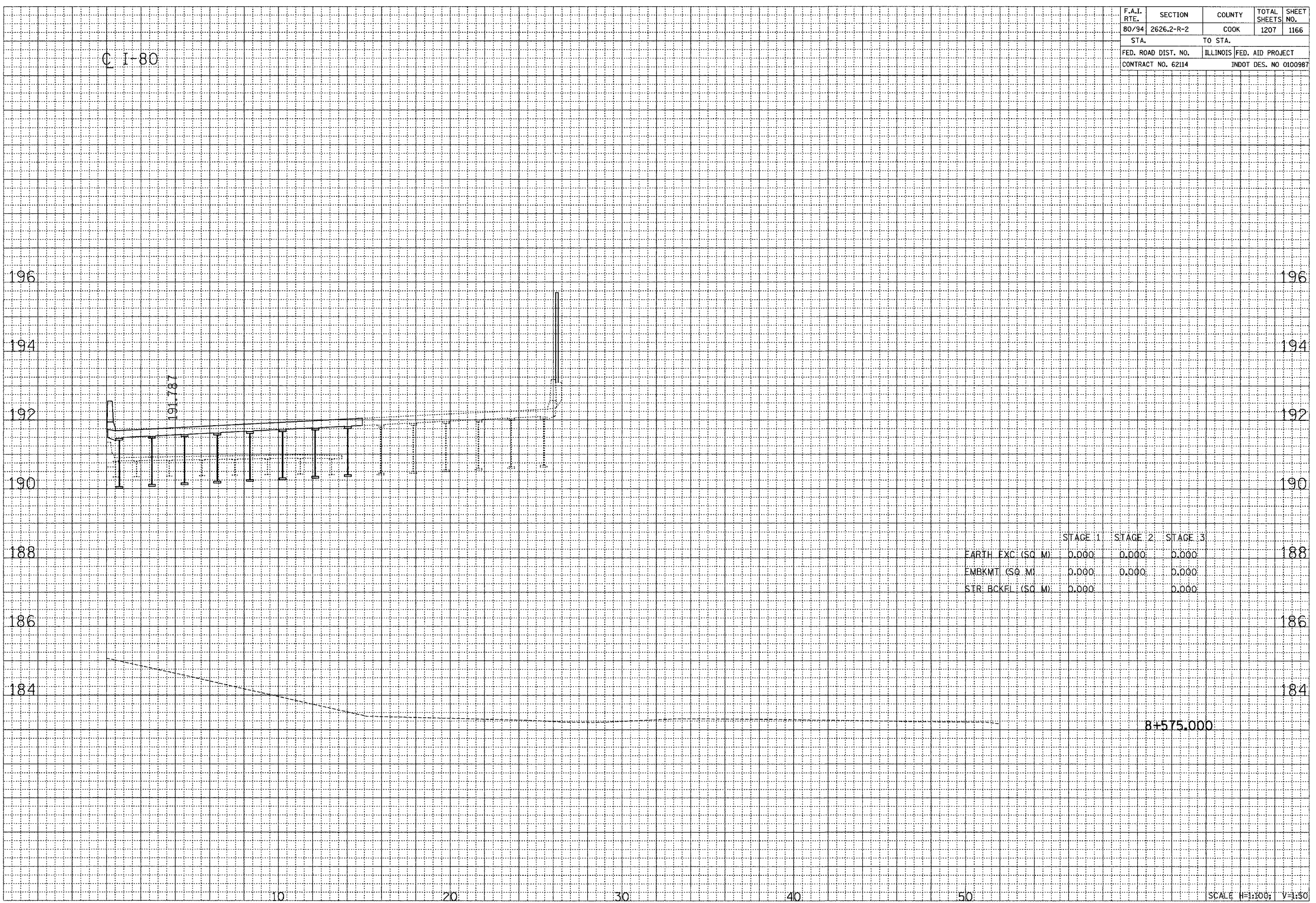

CROSS SECTION - I-80/94/US 6

09/14/2005 05:01:28 AM

F.A.I. RTE.	SECTION	COUNTY	TOTAL SHEETS	SHEET NO.
80/94	2626.2-R-2	COOK	1207	1167
STA.		TO STA.		
FED. ROAD DIST. NO.		ILLINOIS	FED. AID PROJECT	
CONTRACT NO. 62114		INDOT DES. NO 0100987		

FINAL SURVEY	SURVEYED	BY	DATE
NOTE BOOK NO.	PLOTTED		
	AREAS		
	CHECKED		

ORIGINAL SURVEY	SURVEYED	BY	DATE
NOTE BOOK NO.	PLOTTED		
	AREAS		
	CHECKED		

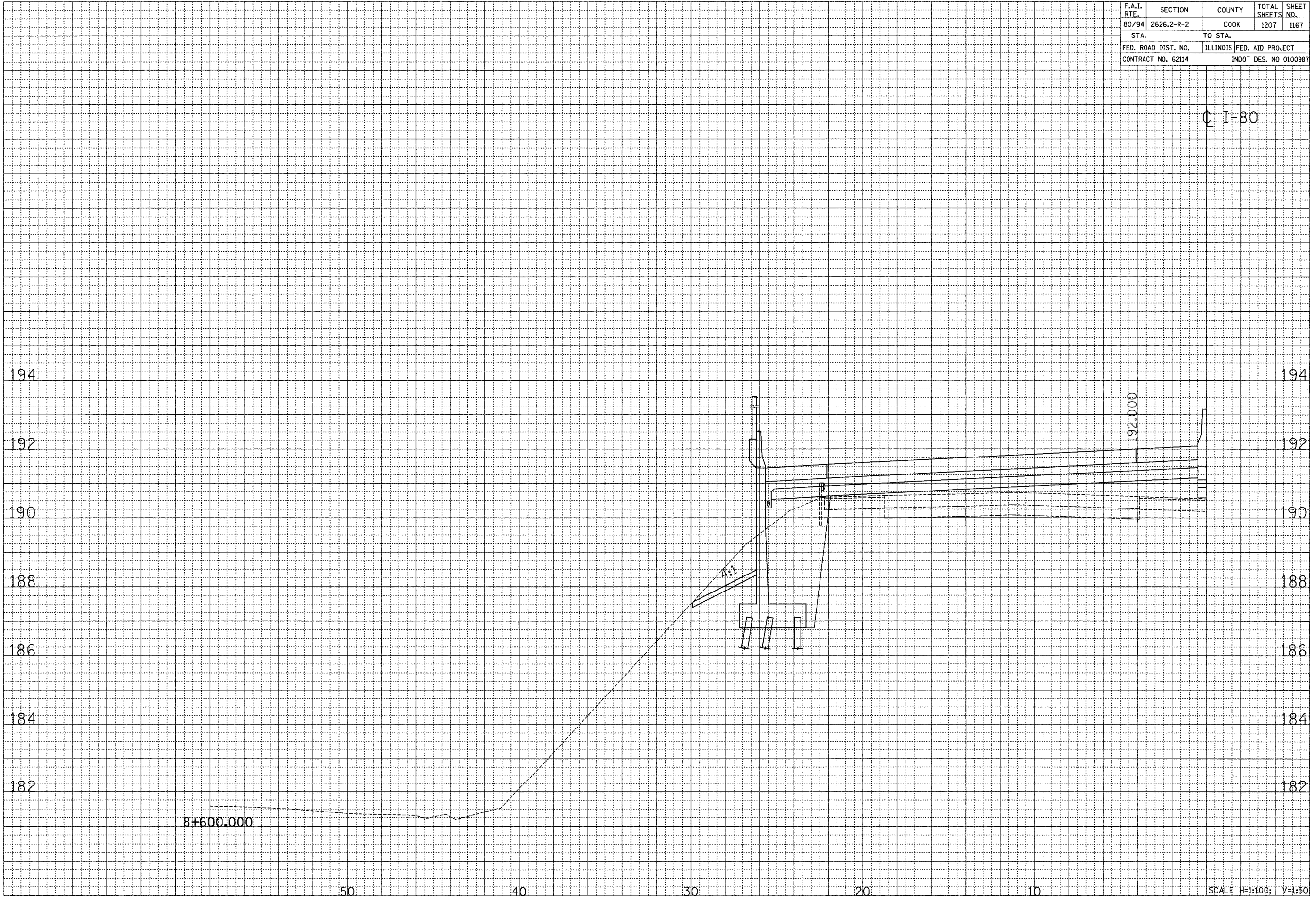

CROSS SECTION - I-80/94/US 6

...:\projects\130626.rvt 08/12/2005 07:23:50 AM

F.A.I. RTE.	SECTION	COUNTY	TOTAL SHEETS	SHEET NO.
80/94	2626.2-R-2	COOK	1207	1168
STA.		TO STA.		
FED. ROAD DIST. NO.		ILLINOIS	FED. AID PROJECT	
CONTRACT NO. 62114		INDOT DES. NO 0100987		

C I-80

FINAL SURVEY	DATE
SURVEYED	BY
NOTE BOOK	
NO.	
AREAS CHECKED	
AREAS CHECKED	

ORIGINAL SURVEY	DATE
SURVEYED	BY
NOTE BOOK	
NO.	
AREAS CHECKED	
AREAS CHECKED	

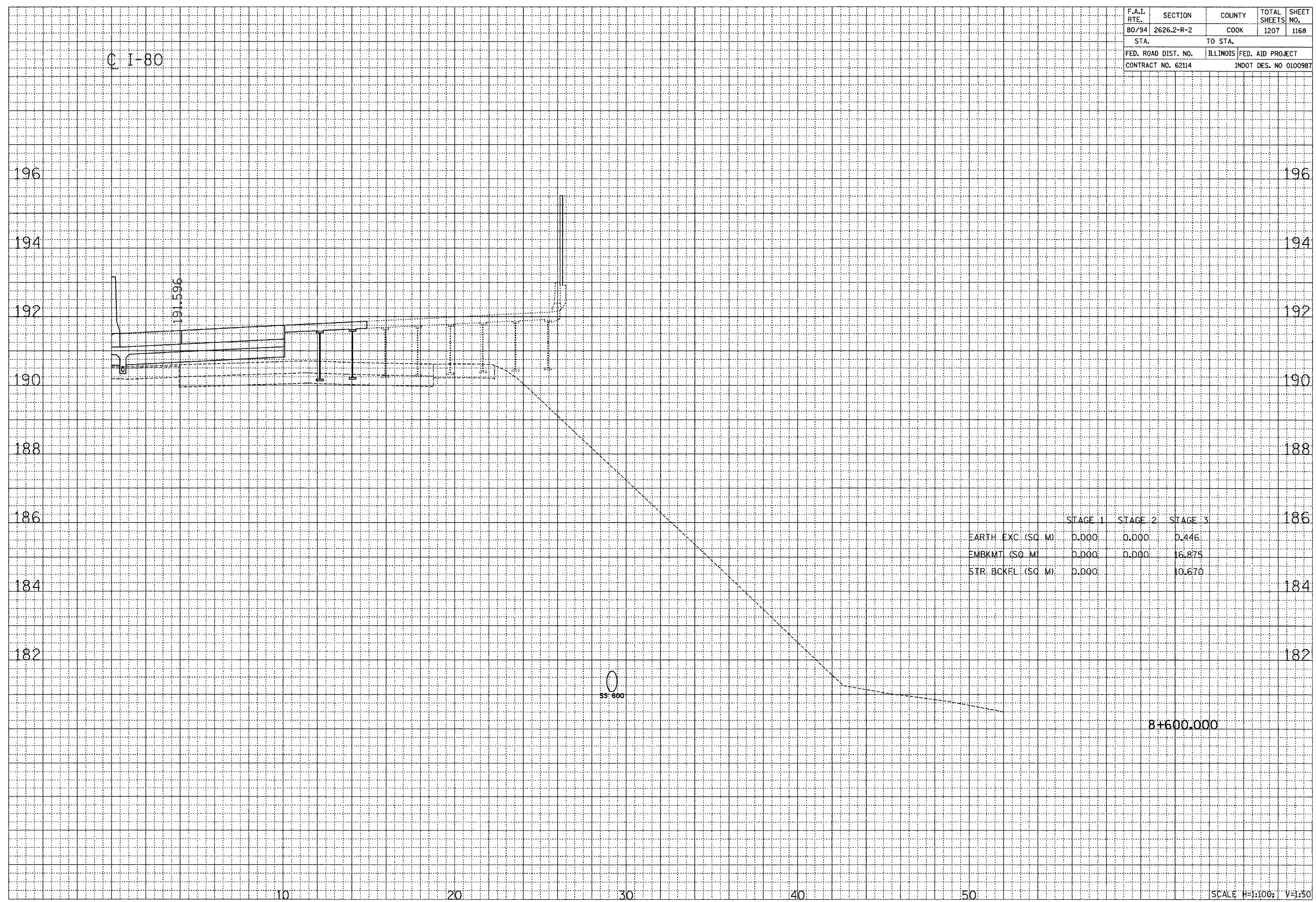

8+600.000

SCALE H=1:100; V=1:50

CROSS SECTION - I-80/94/US 6

F.A.I. RTE.	SECTION	COUNTY	TOTAL SHEETS	SHEET NO.
80/94	2626.2-R-2	COOK	1207	1169
STA.		TO STA.		
FED. ROAD DIST. NO.		ILLINOIS	FED. AID PROJECT	
CONTRACT NO. 62114		INDOT DES. NO 0100987		

FINAL SURVEY	DATE
NO. _____	_____
BY _____	_____
DATE _____	_____
NO. _____	_____
BY _____	_____
DATE _____	_____

ORIGINAL SURVEY	DATE
NO. _____	_____
BY _____	_____
DATE _____	_____
NO. _____	_____
BY _____	_____
DATE _____	_____

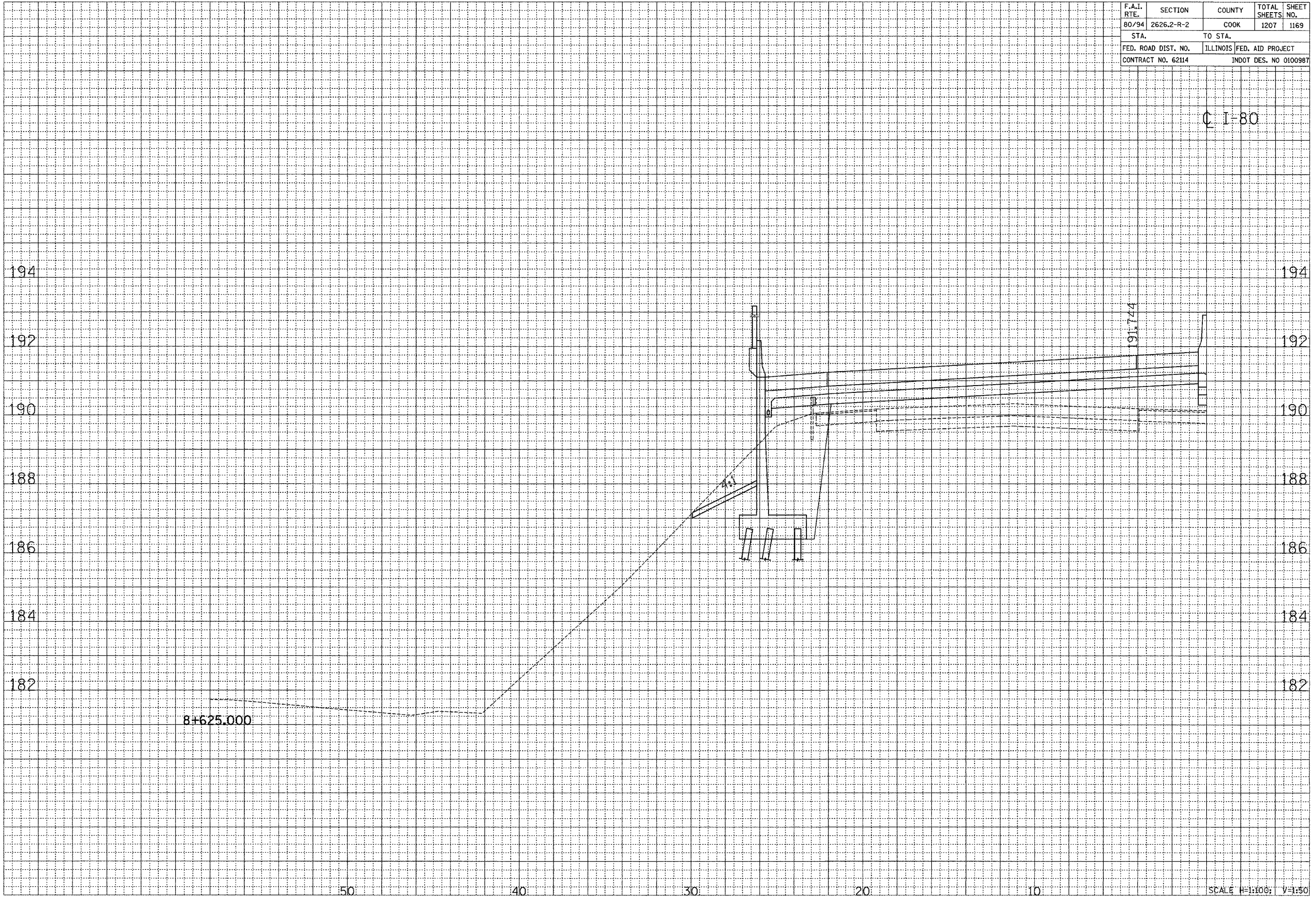

CROSS SECTION - I-80/94/US 6

Scale H=1:100; V=1:50

F.A.I. RTE.	SECTION	COUNTY	TOTAL SHEETS	SHEET NO.
80/94	2626.2-R-2	COOK	1207	1170
STA.		TO STA.		
FED. ROAD DIST. NO.		ILLINOIS	FED. AID PROJECT	
CONTRACT NO. 62114		INDOT DES. NO 0100987		

C I-80

FINAL SURVEY	DATE
SURVEYED	BY
NOTE BOOK	
NO.	
AREAS CHECKED	

ORIGINAL SURVEY	DATE
SURVEYED	BY
NOTE BOOK	
NO.	
AREAS CHECKED	

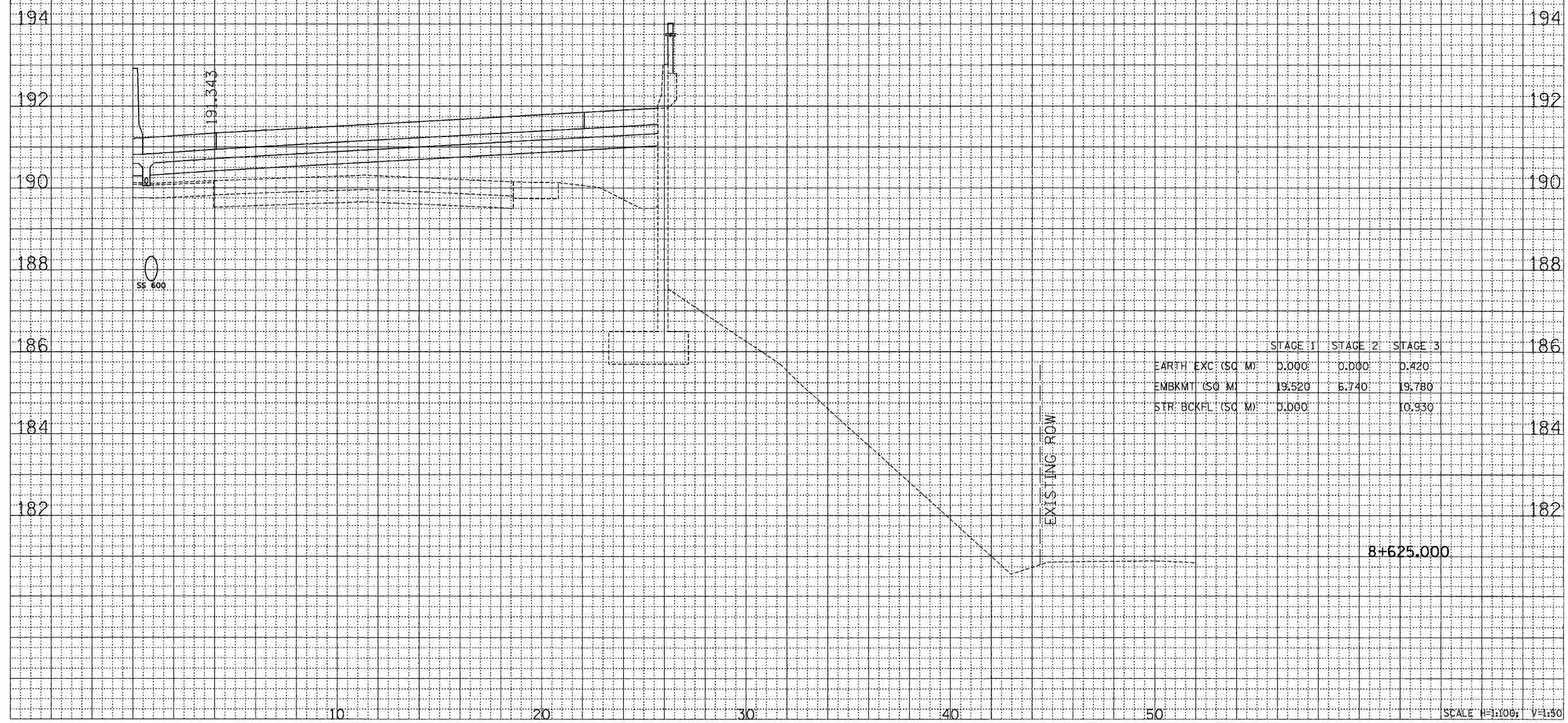

8+625.000

SCALE H=1:100; V=1:50

CROSS SECTION - I-80/94/US 6

F.A.I. RTE.	SECTION	COUNTY	TOTAL SHEETS	SHEET NO.
80/94	2626.2-R-2	COOK	1207	1171
STA.		TO STA.		
FED. ROAD DIST. NO.		ILLINOIS FED. AID PROJECT		
CONTRACT NO. 62114		INDOT DES. NO 0100987		

FINAL SURVEY	SURVEYED	BY	DATE
NOTE BOOK NO.	PLOTTED		
	AREAS		
	CHECKED		

ORIGINAL SURVEY	SURVEYED	BY	DATE
NOTE BOOK NO.	PLOTTED		
	AREAS		
	CHECKED		

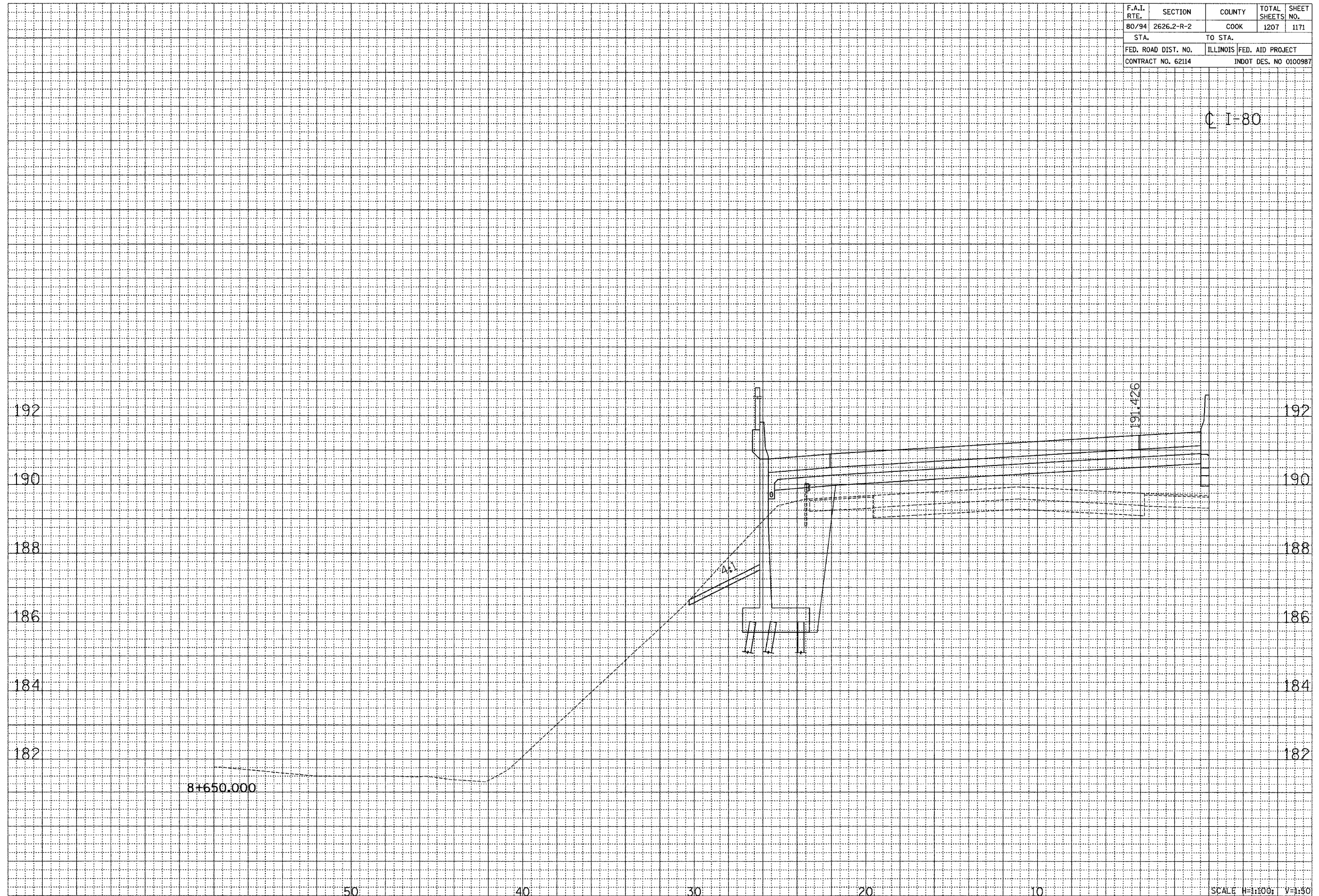

8+650.000

SCALE H=1:100; V=1:30

CROSS SECTION - I-80/94/US 6

F.A.I. RTE.	SECTION	COUNTY	TOTAL SHEETS	SHEET NO.
80/94	2626.2-R-2	COOK	1207	1172
STA.		TO STA.		
FED. ROAD DIST. NO.	ILLINOIS	FED. AID PROJECT		
CONTRACT NO. 62114	INDOT DES. NO 0100987			

C I-80

FINAL SURVEY	DATE
NOTE BOOK NO.	
SURVEYED BY	
TEMPLATE	
AREAS CHECKED	
REVISIONS CHECKED	

ORIGINAL SURVEY	DATE
NOTE BOOK NO.	
SURVEYED BY	
TEMPLATE	
AREAS CHECKED	
REVISIONS CHECKED	

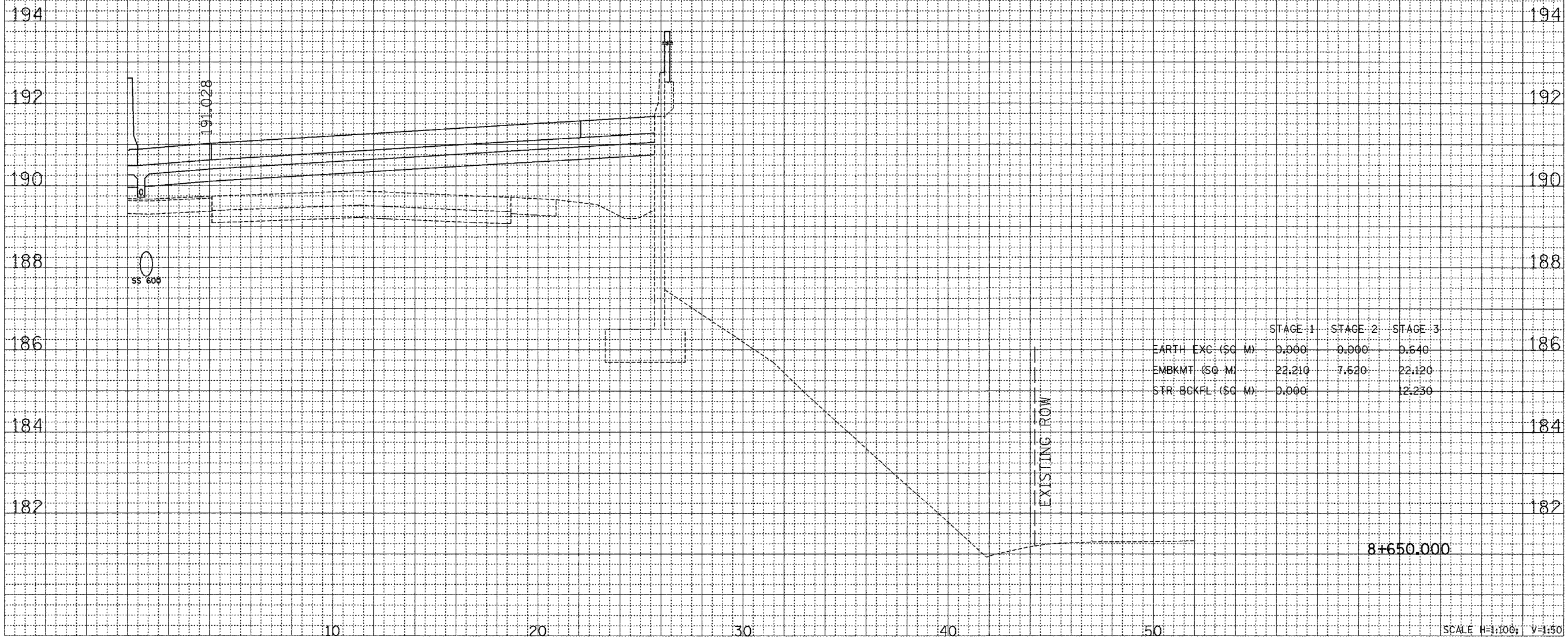

CROSS SECTION - I-80/94/US 6

F.A.I. RTE.	SECTION	COUNTY	TOTAL SHEETS	SHEET NO.
80/94	2626.2-R-2	COOK	1207	1173
STA.		TO STA.		
FED. ROAD DIST. NO.	ILLINOIS	FED. AID PROJECT		
CONTRACT NO. 62114		INDOT DES. NO 0100987		

C I-80

FINAL SURVEY	DATE
BY	
REVIEWED	
DATE	
BY	
NOTE BOOK	
NO.	
TEMPLATE	
AREAS	
CHECKED	

ORIGINAL SURVEY	DATE
BY	
REVIEWED	
DATE	
BY	
NOTE BOOK	
NO.	
TEMPLATE	
AREAS	
CHECKED	

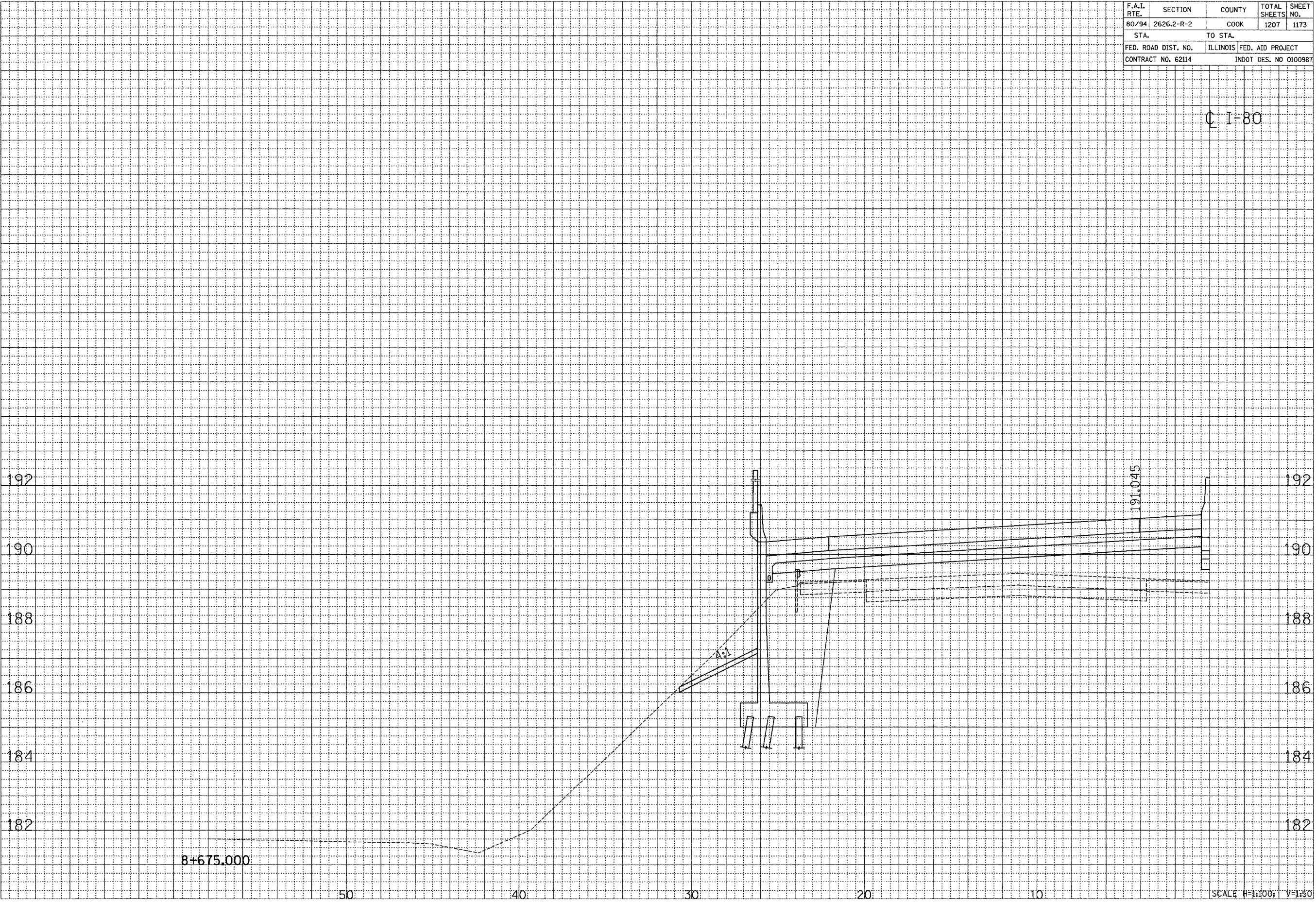

SCALE H=1:100; V=1:50

CROSS SECTION - I-80/94/US 6

\\p01665188\B011818.dwg 06/11/2006 01:24:28 PM

F.A.I. RTE.	SECTION	COUNTY	TOTAL SHEETS	SHEET NO.
80/94	2626.2-R-2	COOK	1207	1174
STA.		TO STA.		
FED. ROAD DIST. NO.		ILLINOIS	FED. AID PROJECT	
CONTRACT NO. 62114		INDOT DES. NO 0100987		

C I-80

DATE	BY
DATE	BY
DATE	BY

DATE	BY
DATE	BY
DATE	BY

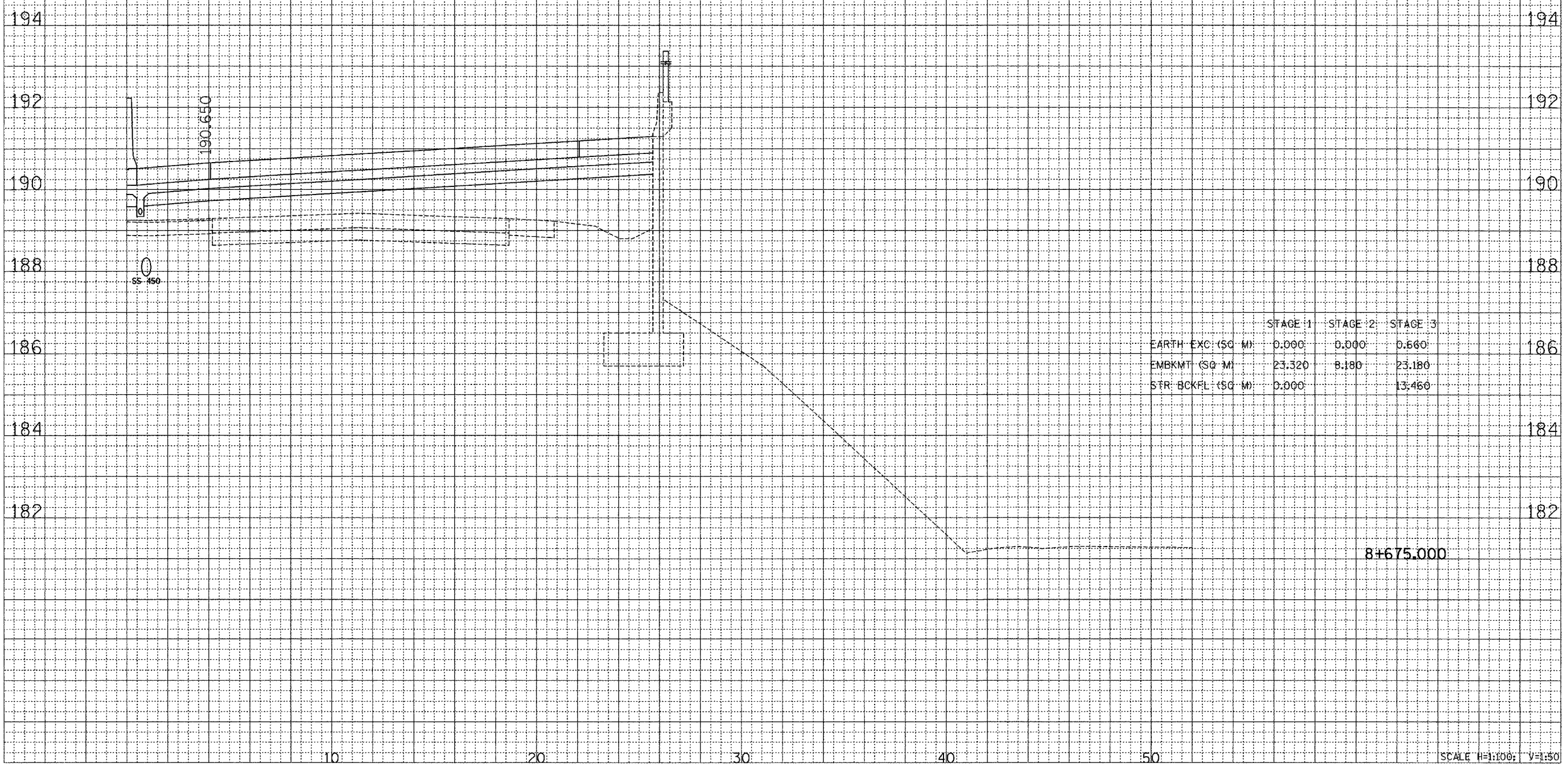

SCALE H=1:100; V=1:50
CROSS SECTION - I-80/94/US 6

...:\Share\1519\62114.r35 05/17/2005 01:24:36 PM

F.A.I. RTE.	SECTION	COUNTY	TOTAL SHEETS	SHEET NO.
80/94	2626.2-R-2	COOK	1207	1175
STA.		TO STA.		
FED. ROAD DIST. NO.		ILLINOIS FED. AID PROJECT		
CONTRACT NO. 62114		INDOT DES. NO 0100987		

FINAL SURVEY	DATE
BLANKED	BY
NOTE BOOK	
NO.	
AREAS CHECKED	

ORIGINAL SURVEY	DATE
BLANKED	BY
NOTE BOOK	
NO.	
AREAS CHECKED	

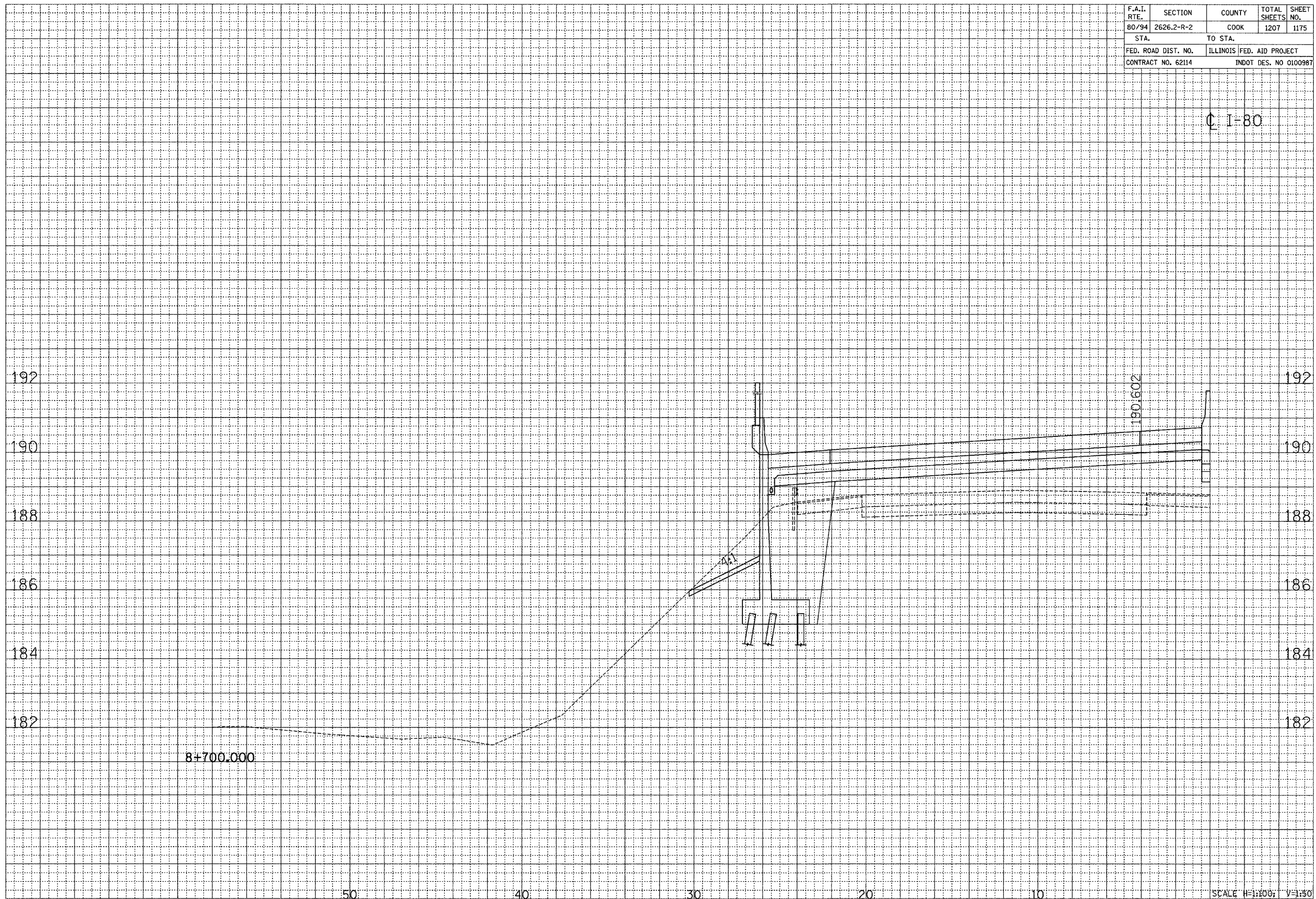

Q I-80

SCALE H=1:100; V=1:50

CROSS SECTION - I-80/94/US 6

...:\SHERES\ASB0214.ras 06/11/2005 01:24:27 PM

F.A.I. RTE.	SECTION	COUNTY	TOTAL SHEETS	SHEET NO.
80/94	2626.2-R-2	COOK	1207	1176
STA.		TO STA.		
FED. ROAD DIST. NO.		ILLINOIS	FED. AID PROJECT	
CONTRACT NO. 62114		INDOT DES. NO 0100987		

© I-80

FINAL SURVEY	SURVEYED	BY	DATE
NOTE BOOK NO.	TEMPLATE AREAS CHECKED		

ORIGINAL SURVEY	SURVEYED	BY	DATE
NOTE BOOK NO.	TEMPLATE AREAS CHECKED		

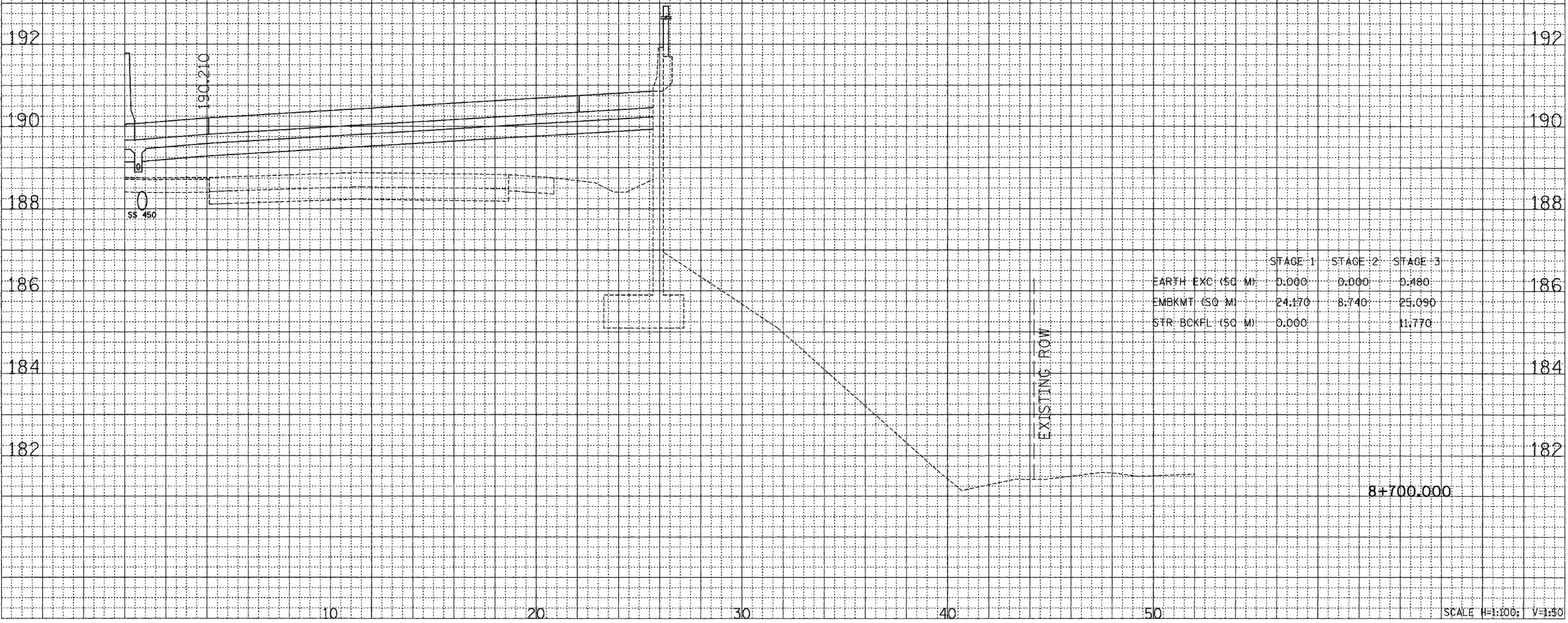

SCALE H=1:100; V=1:50

CROSS SECTION - I-80/94/US 6

\\shereh\sl\6003a.ms 06/11/2005 01:24:27 PM

F.A.I. RTE.	SECTION	COUNTY	TOTAL SHEETS	SHEET NO.
80/94	2626.2-R-2	COOK	1207	1177
STA.		TO STA.		
FED. ROAD DIST. NO.		ILLINOIS FED. AID PROJECT		
CONTRACT NO. 62114		INDOT DES. NO 0100987		

FINAL SURVEY	DATE
NO. _____	_____
BY _____	_____
DATE _____	_____
REVISIONS	DATE
NO. _____	_____
BY _____	_____
DATE _____	_____
REVISIONS	DATE
NO. _____	_____
BY _____	_____
DATE _____	_____

ORIGINAL SURVEY	DATE
NO. _____	_____
BY _____	_____
DATE _____	_____
REVISIONS	DATE
NO. _____	_____
BY _____	_____
DATE _____	_____
REVISIONS	DATE
NO. _____	_____
BY _____	_____
DATE _____	_____

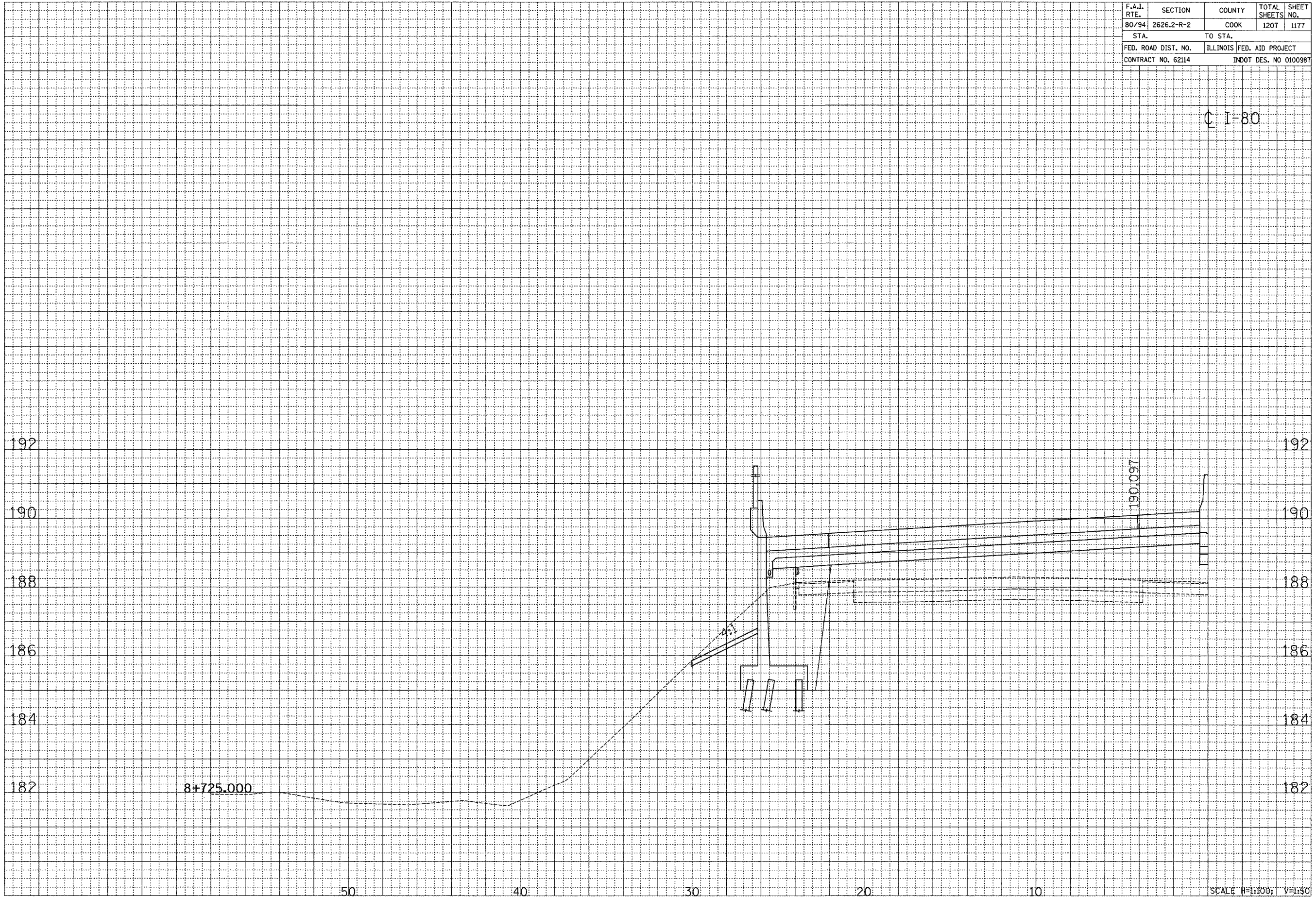

CROSS SECTION - I-80/94/US 6

SCALE H=1:100; V=1:50

F.A.L. RTE.	SECTION	COUNTY	TOTAL SHEETS	SHEET NO.
80/94	2626.2-R-2	COOK	1207	1178
STA.		TO STA.		
FED. ROAD DIST. NO.		ILLINOIS	FED. AID PROJECT	
CONTRACT NO. 62114		INDOT DES. NO 0100987		

© I-80

FINAL SURVEY	DATE
NO. _____	_____
BY _____	_____
NO. _____	_____
BY _____	_____
NO. _____	_____
BY _____	_____
NO. _____	_____

ORIGINAL SURVEY	DATE
NO. _____	_____
BY _____	_____
NO. _____	_____
BY _____	_____
NO. _____	_____
BY _____	_____
NO. _____	_____

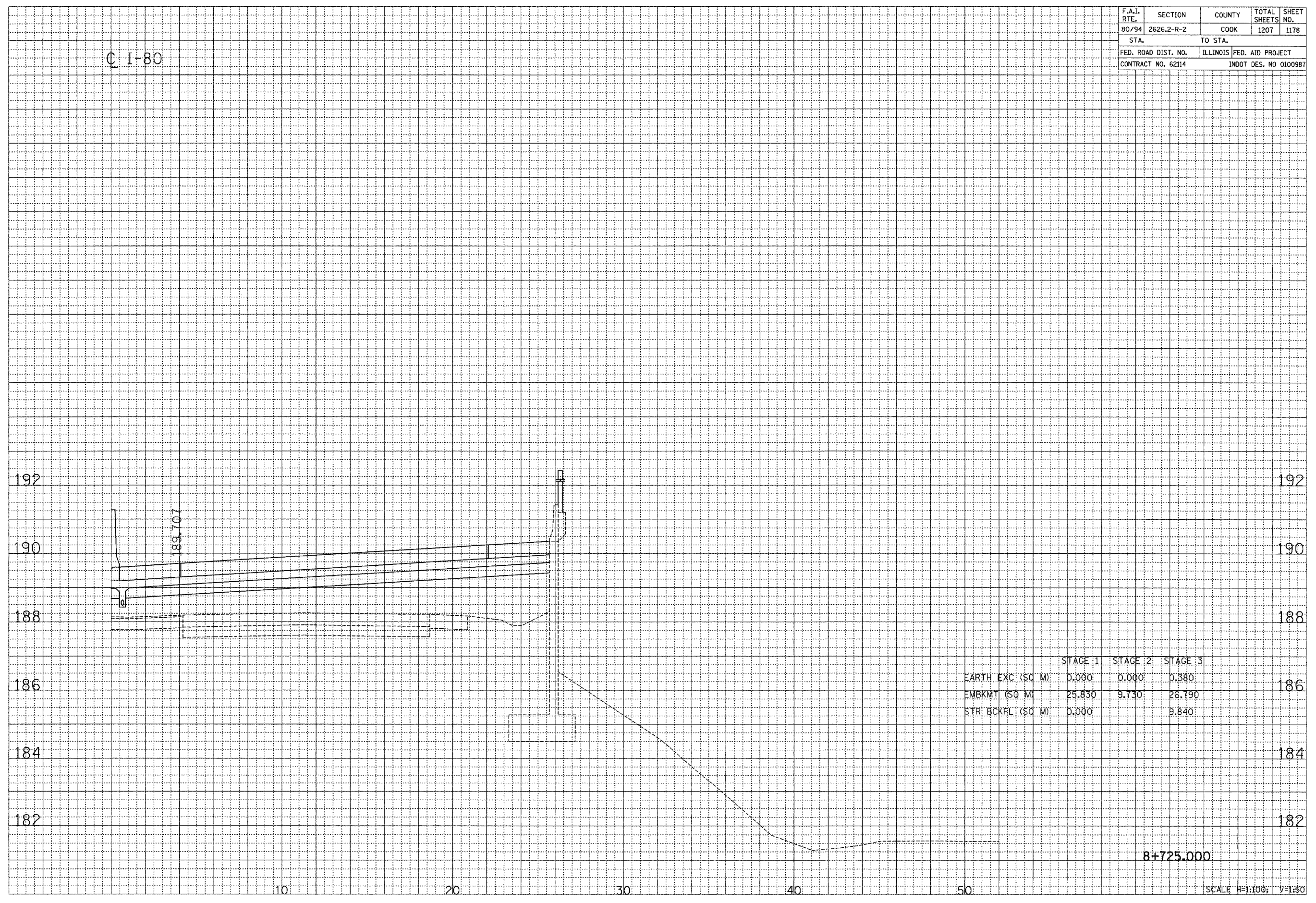

8+725.000

SCALE H=1:100; V=1:50

CROSS SECTION - I-80/94/US 6

F.A.I. RTE.	SECTION	COUNTY	TOTAL SHEETS	SHEET NO.
80/94	2626.2-R-2	COOK	1207	1179
STA.		TO STA.		
FED. ROAD DIST. NO.		ILLINOIS FED. AID PROJECT		
CONTRACT NO. 62114		INDOT DES. NO 0100987		

FINAL SURVEY	DATE
SURVEYED	
PLOTTED	
AREAS	
CHECKED	
NO.	

ORIGINAL SURVEY	DATE
SURVEYED	
PLOTTED	
AREAS	
CHECKED	
NO.	

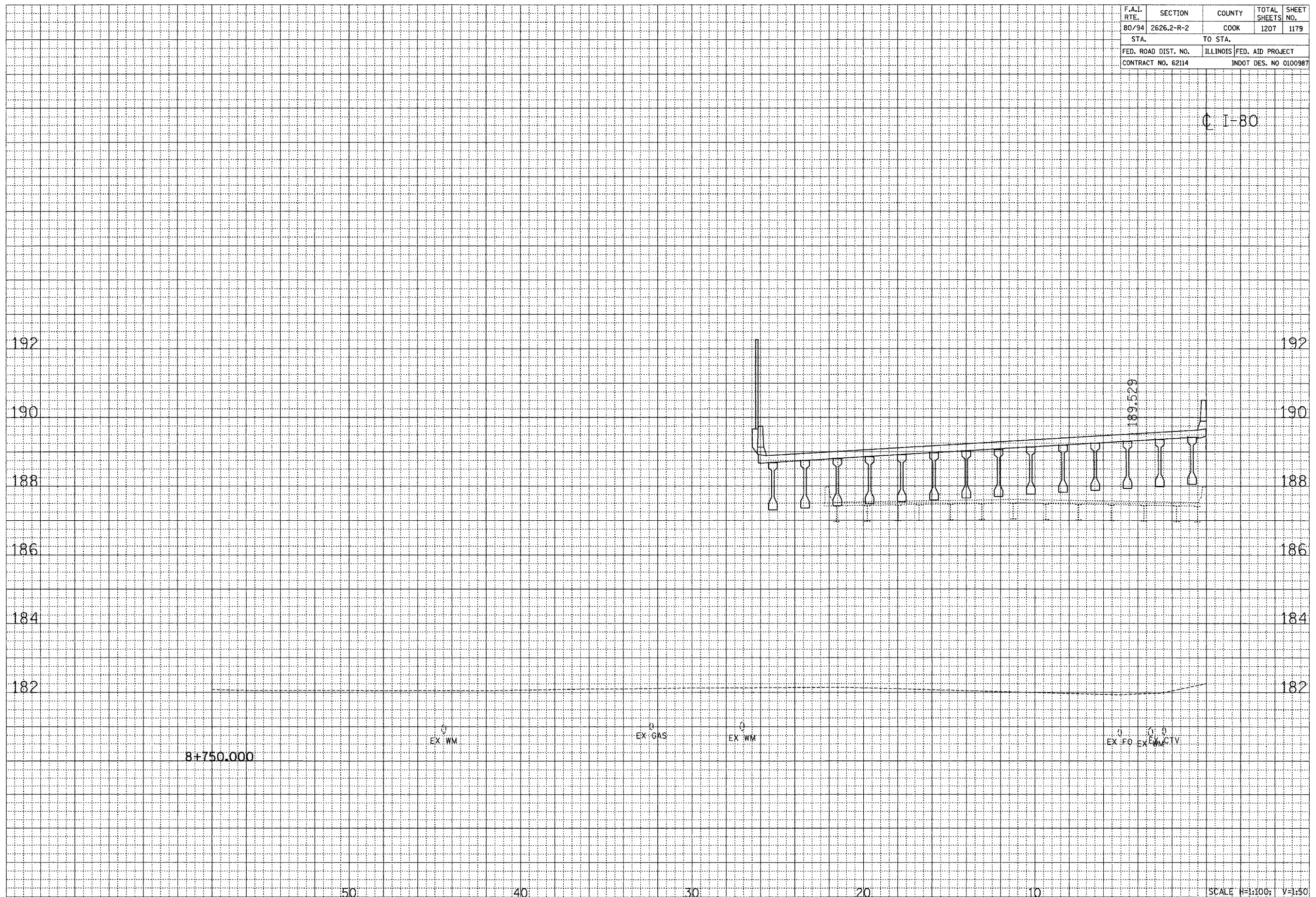

CROSS SECTION - I-80/94/US 6

F.A.I. RTE.	SECTION	COUNTY	TOTAL SHEETS	SHEET NO.
80/94	2626.2-R-2	COOK	1207	1180
STA.		TO STA.		
FED. ROAD DIST. NO.		ILLINOIS FED. AID PROJECT		
CONTRACT NO. 62114		INDOT DES. NO 0100987		

© I-80

FINAL SURVEY	DATE
SURVEYED	BY
NOTE BOOK	NO.
TEMPLATE	AREAS CHECKED
AREAS CHECKED	

ORIGINAL SURVEY	DATE
SURVEYED	BY
NOTE BOOK	NO.
TEMPLATE	AREAS CHECKED
AREAS CHECKED	

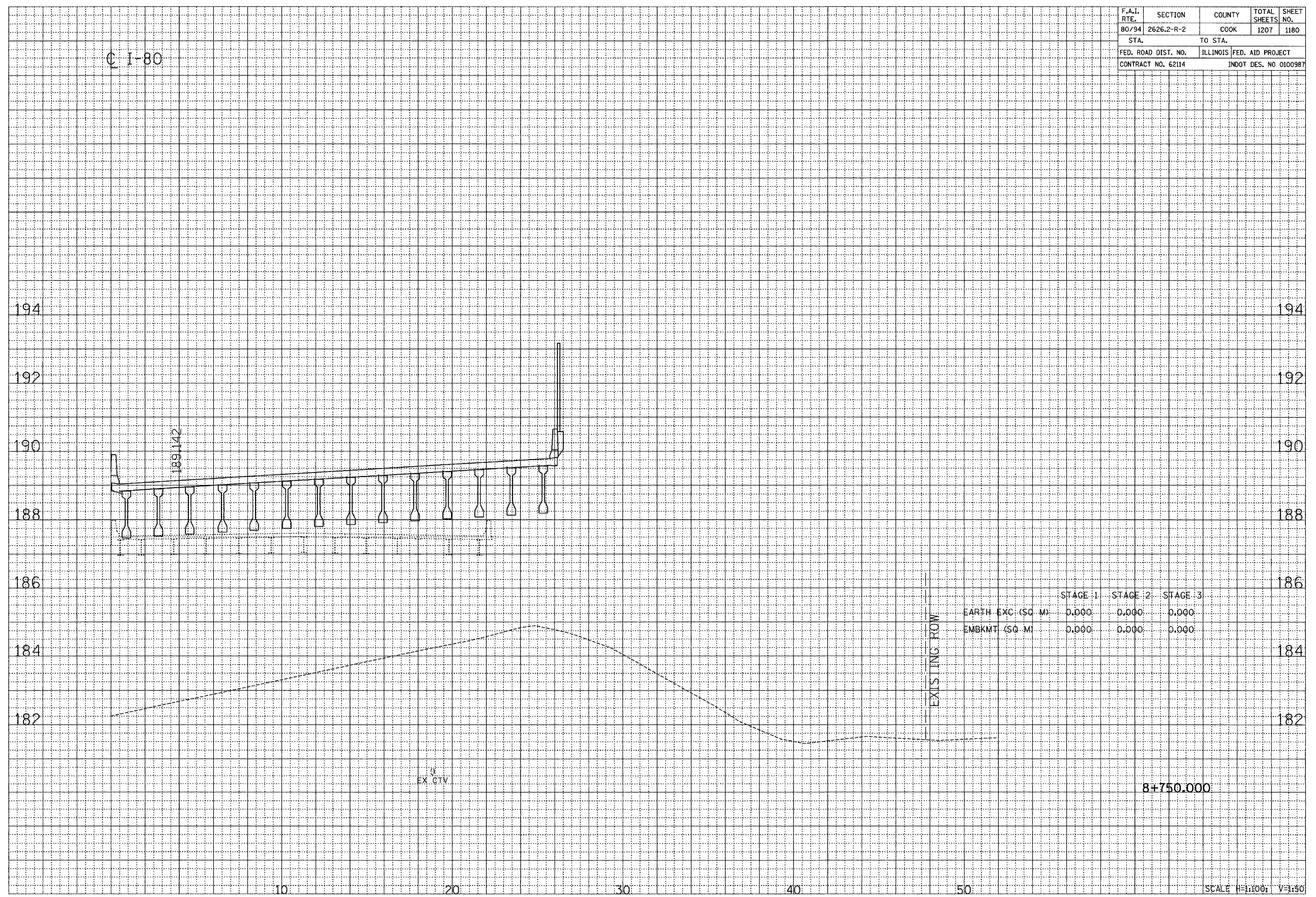

CROSS SECTION - I-80/94/US 6

Small vertical text at the bottom right corner, likely a file path or version number.

F.A.I. RTE.	SECTION	COUNTY	TOTAL SHEETS	SHEET NO.
80/94	2626.2-R-2	COOK	1207	1181
STA.		TO STA.		
FED. ROAD DIST. NO.		ILLINOIS FED. AID PROJECT		
CONTRACT NO. 62114		INDOT DES. NO 0100987		

FINAL SURVEY	DATE
NO. _____	_____
BY _____	_____
REVIEWED	DATE
NOTE BOOK	_____
NO. _____	_____
AREAS CHECKED	_____
AREAS CHECKED	_____

ORIGINAL SURVEY	DATE
NO. _____	_____
BY _____	_____
REVIEWED	DATE
NOTE BOOK	_____
NO. _____	_____
AREAS CHECKED	_____
AREAS CHECKED	_____

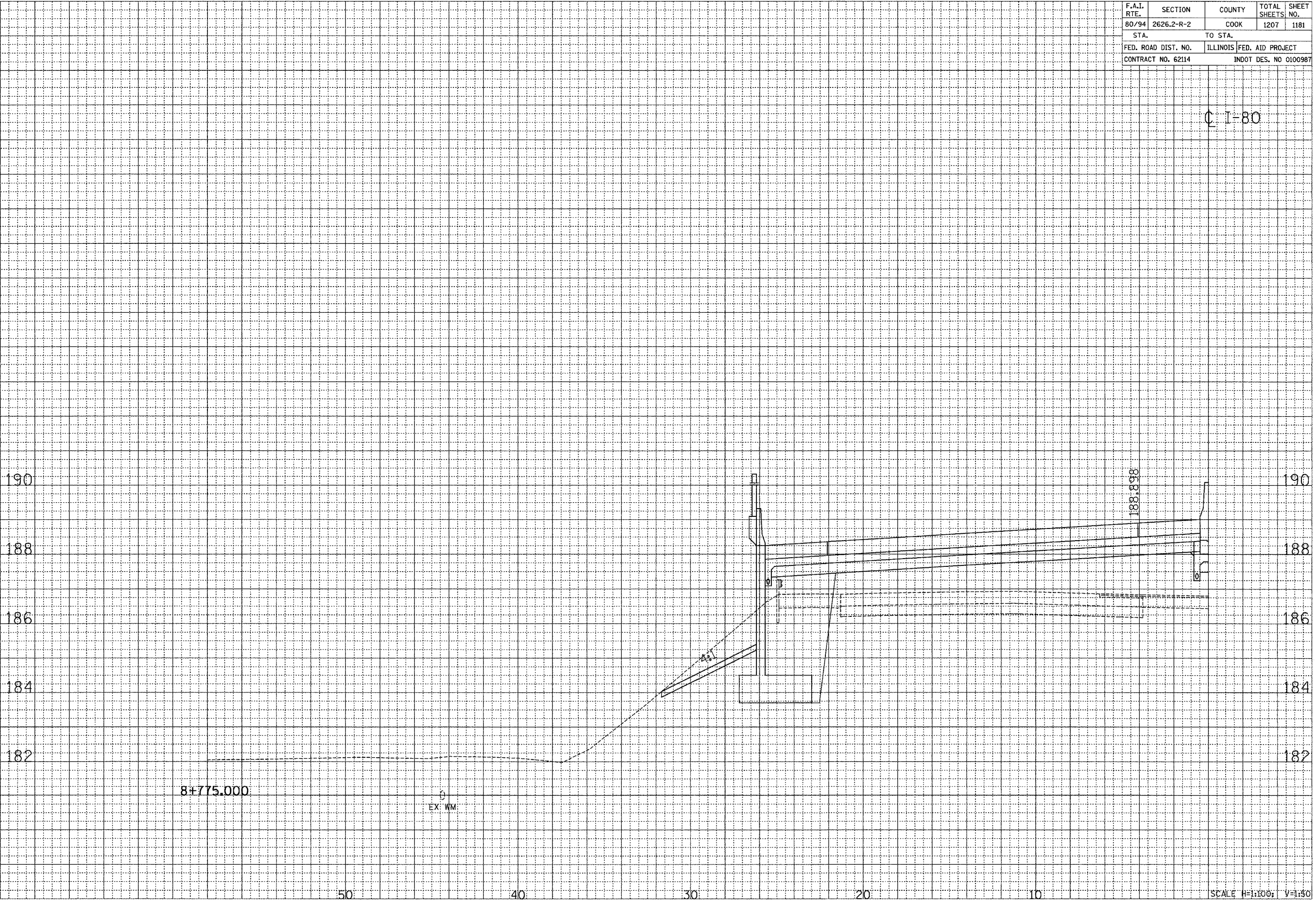

C I-80

SCALE H=1:100; V=1:50

CROSS SECTION - I-80/94/US 6

F.A.I. RTE.	SECTION	COUNTY	TOTAL SHEETS	SHEET NO.
80/94	2626.2-R-2	COOK	1207	1182
STA.		TO STA.		
FED. ROAD DIST. NO.		ILLINOIS	FED. AID PROJECT	
CONTRACT NO. 62114		INDOT DES. NO 0100987		

C I-80

FINAL SURVEY	DATE
SURVEYED	
BY	
PLOTTED	
NOTE BOOK	
NO.	
AREAS CHECKED	

ORIGINAL SURVEY	DATE
SURVEYED	
BY	
PLOTTED	
NOTE BOOK	
NO.	
AREAS CHECKED	

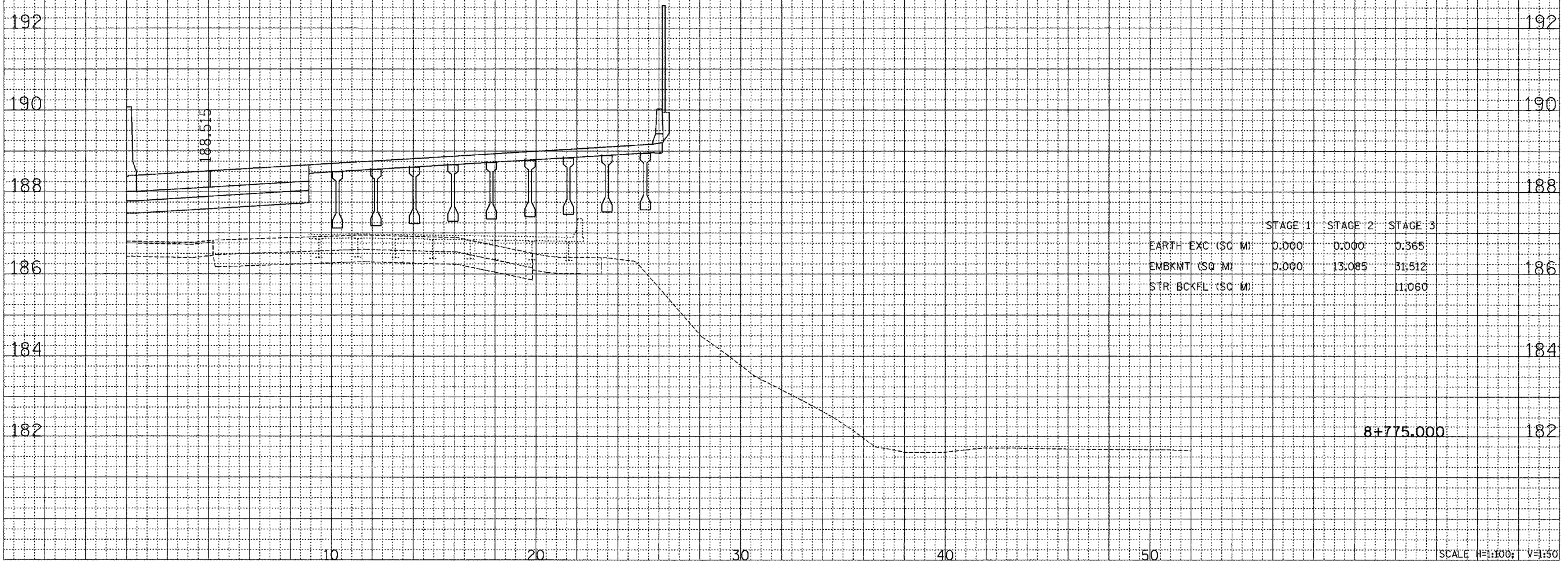

CROSS SECTION - I-80/94/US 6

...:\mexis\w\0100987-06 05/14/2005 09:02:20 AM

F.A.I. RTE.	SECTION	COUNTY	TOTAL SHEETS	SHEET NO.
80/94	2626.2-R-2	COOK	1207	1183
STA.		TO STA.		
FED. ROAD DIST. NO.		ILLINOIS	FED. AID PROJECT	
CONTRACT NO. 62114		INDOT DES. NO 0100987		

FINAL SURVEY	DATE
SURVEYED	BY
NOTE BOOK	
NO.	
AREAS CHECKED	

ORIGINAL SURVEY	DATE
SURVEYED	BY
NOTE BOOK	
NO.	
AREAS CHECKED	

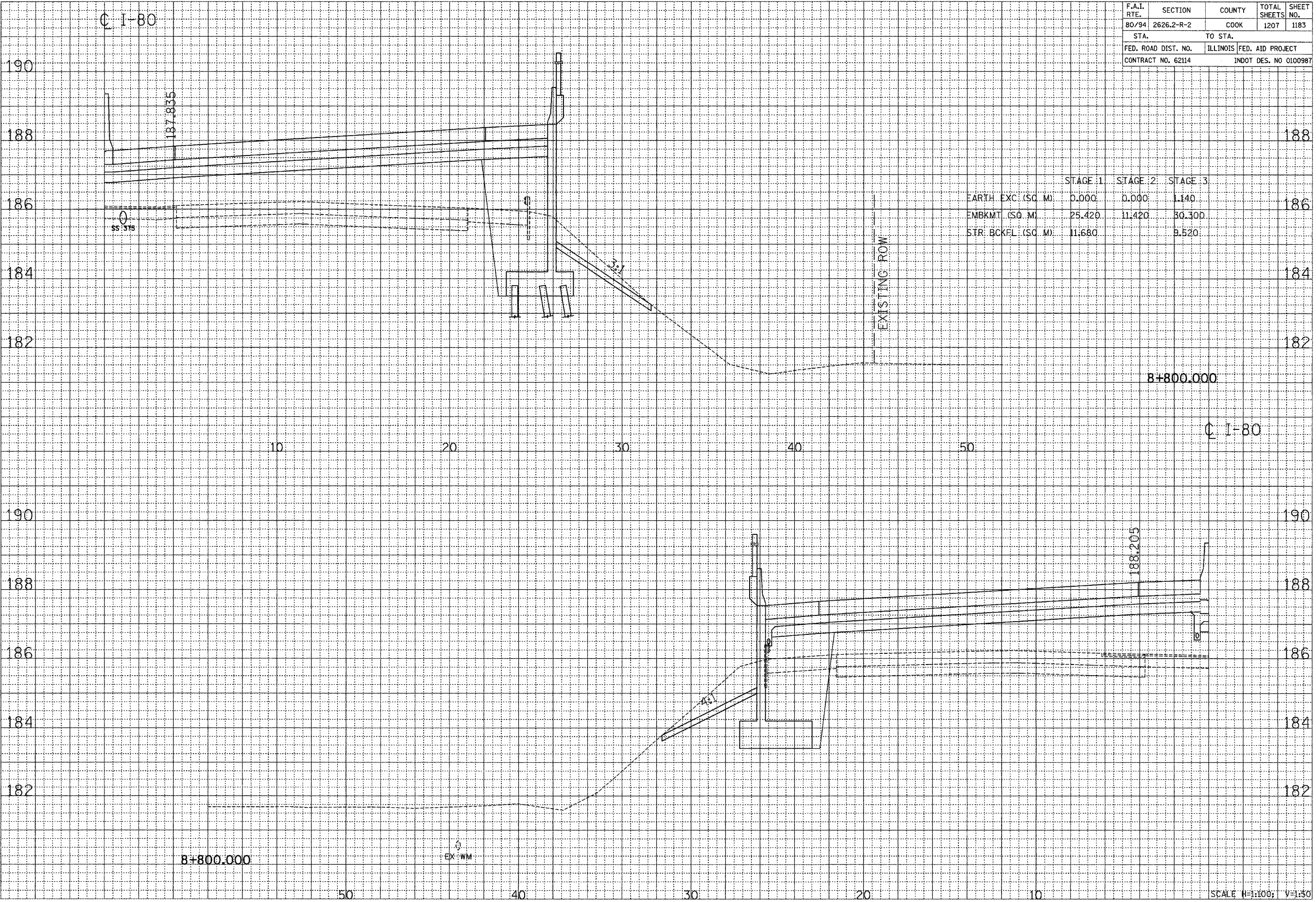

CROSS SECTION - I-80/94/US 6

... 06/21/2005 08:05:27 AM

F.A.I. RTE.	SECTION	COUNTY	TOTAL SHEETS	SHEET NO.
80/94	2626.2-R-2	COOK	1207	1184
STA.		TO STA.		
FED. ROAD DIST. NO.		ILLINOIS FED. AID PROJECT		
CONTRACT NO. 62114		INDOT DES. NO 0100987		

FINAL SURVEY	DATE
NO.	
BY	
DATE	
NO.	
BY	
DATE	
NO.	
BY	
DATE	
NO.	

ORIGINAL SURVEY	DATE
NO.	
BY	
DATE	
NO.	
BY	
DATE	
NO.	
BY	
DATE	
NO.	

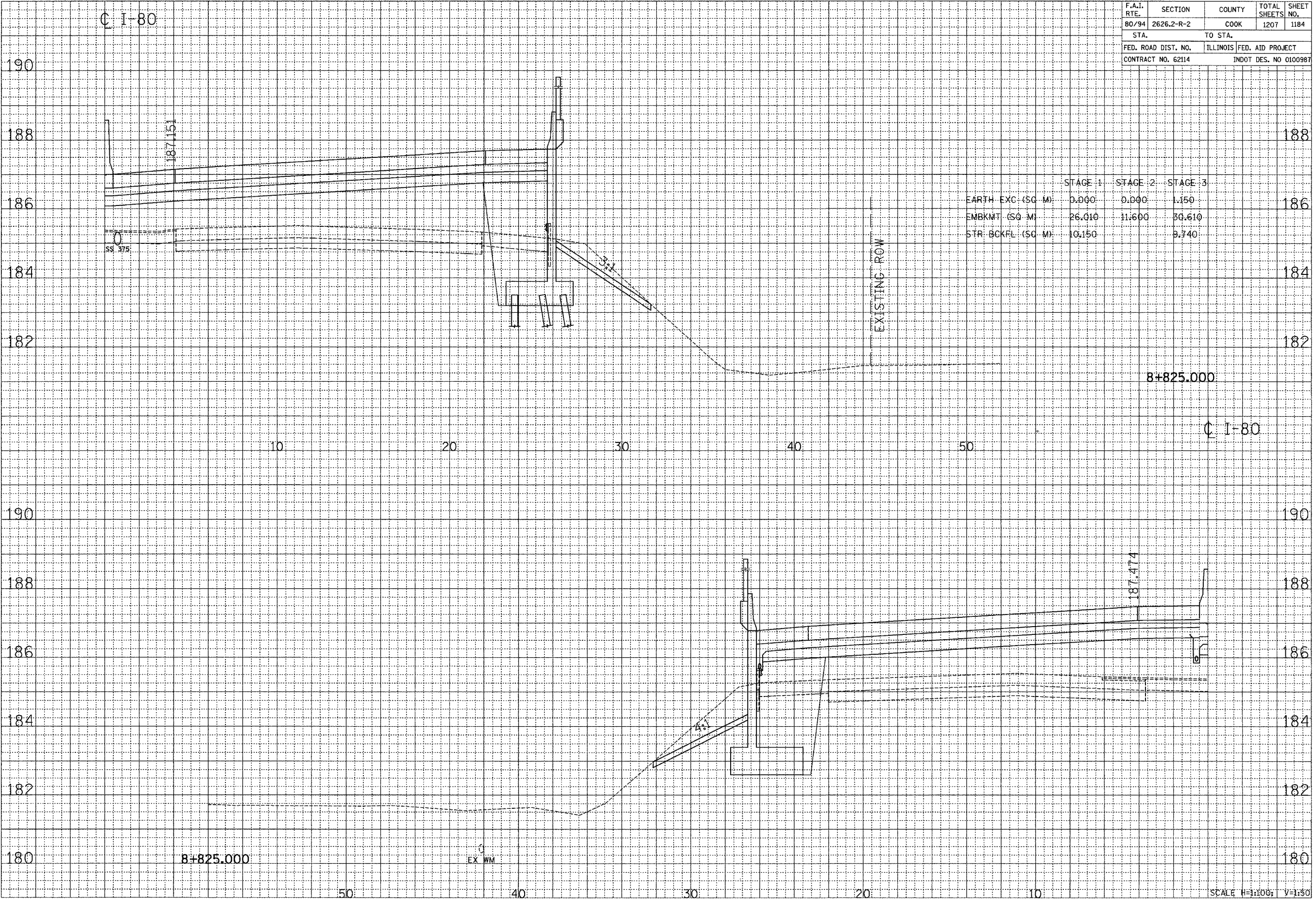

CROSS SECTION - I-80/94/US 6

Sheets 1001001184.dwg 09/14/2005 09:02:55 AM

F.A.I. RTE.	SECTION	COUNTY	TOTAL SHEETS	SHEET NO.
80/94	2626.2-R-2	COOK	1207	1185
STA.		TO STA.		
FED. ROAD DIST. NO.		ILLINOIS FED. AID PROJECT		
CONTRACT NO. 62114		INDOT DES. NO 0100987		

BY	DATE
FINAL SURVEY	
PLOTTED	
NOTE BOOK	
AREAS DATE	
AREAS CHECKED	
NO.	

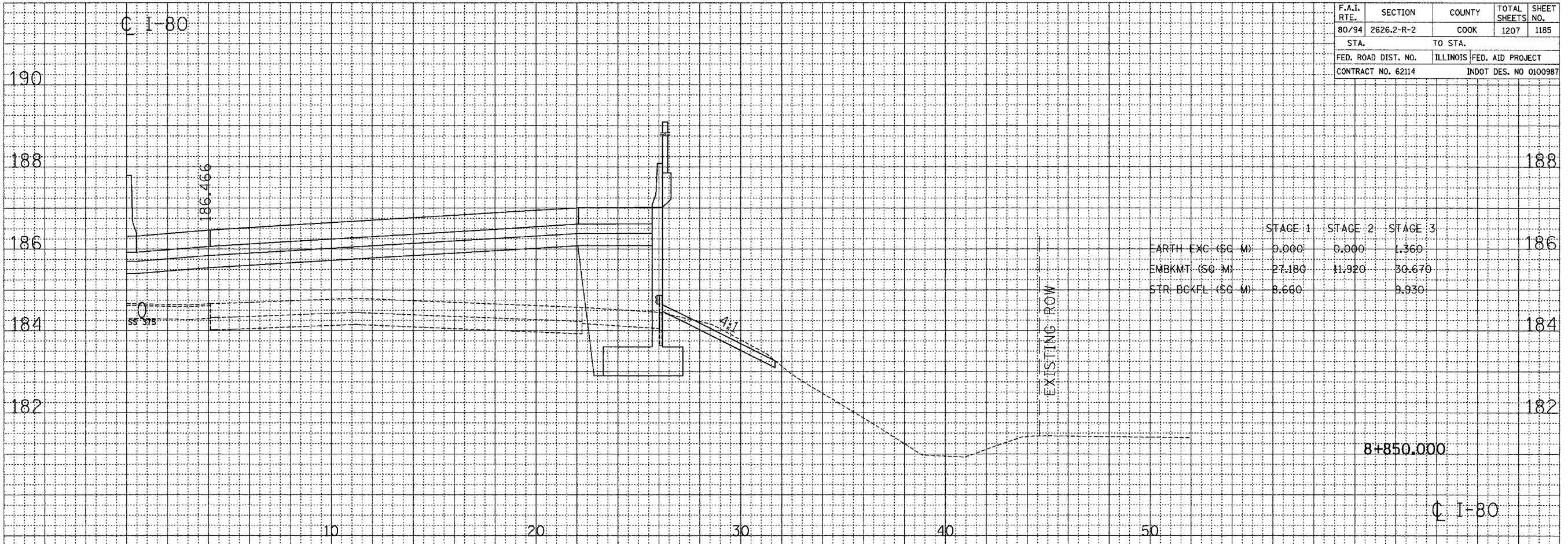

BY	DATE
ORIGINAL SURVEY	
PLOTTED	
NOTE BOOK	
AREAS DATE	
AREAS CHECKED	
NO.	

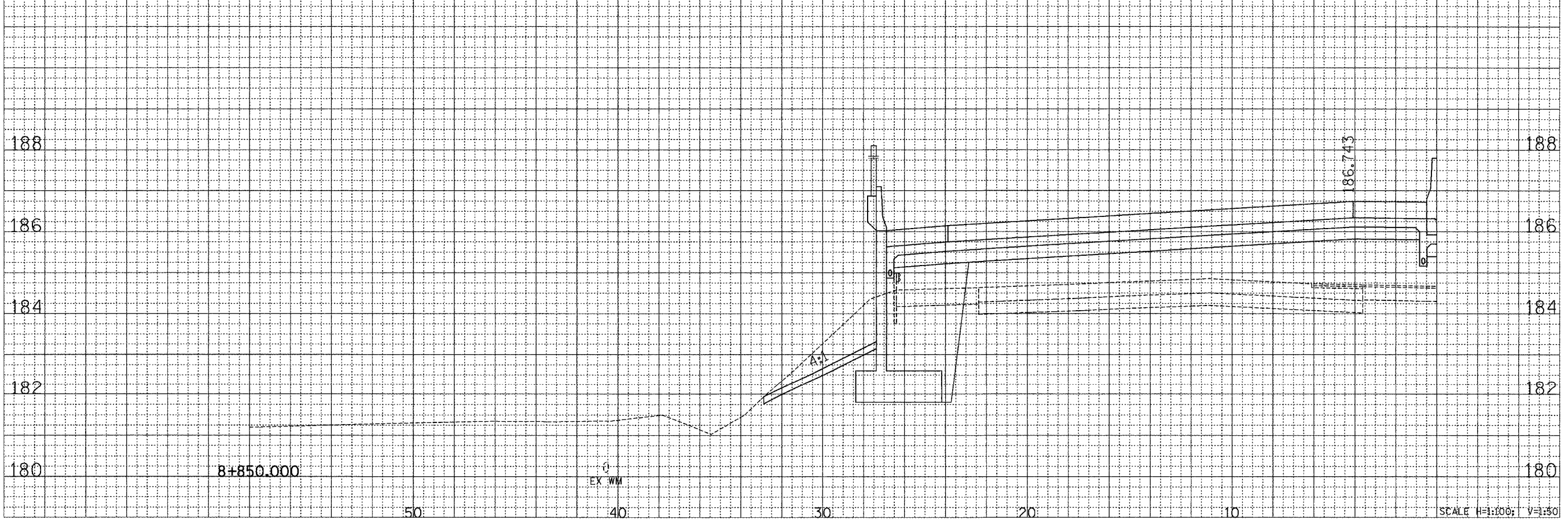

CROSS SECTION - I-80/94/US 6

03/14/2005 08:03:02 AM

F.A.I. RTE.	SECTION	COUNTY	TOTAL SHEETS	SHEET NO.
80/94	2626.2-R-2	COOK	1207	1188
STA.		TO STA.		
FED. ROAD DIST. NO.		ILLINOIS FED. AID PROJECT		
CONTRACT NO. 62114		INDOT DES. NO 0100987		

FINAL SURVEY	BY	DATE
SURVEYED		
NOTE BOOK		
NO.		
AREAS CHECKED		

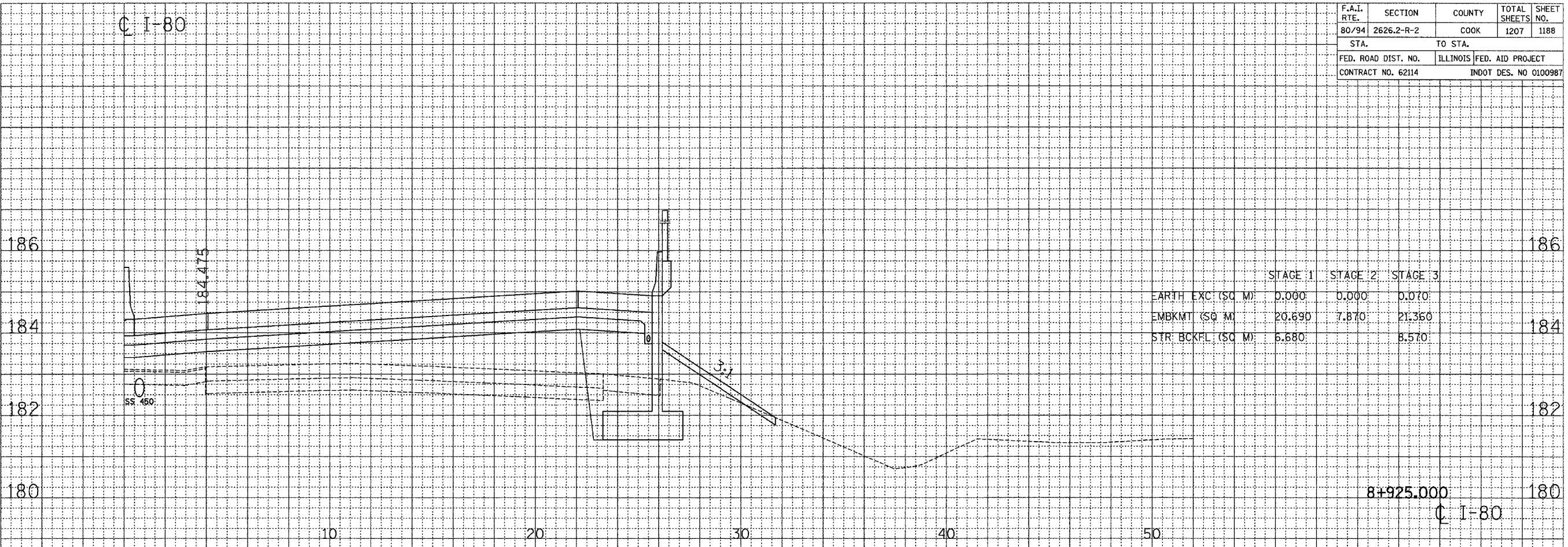

	STAGE 1	STAGE 2	STAGE 3
EARTH EXC (SQ M)	0.000	0.000	0.070
EMBKMT (SQ M)	20.890	7.870	21.360
STR. BCKFL (SQ M)	6.680		8.570

ORIGINAL SURVEY	BY	DATE
SURVEYED		
NOTE BOOK		
NO.		
AREAS CHECKED		

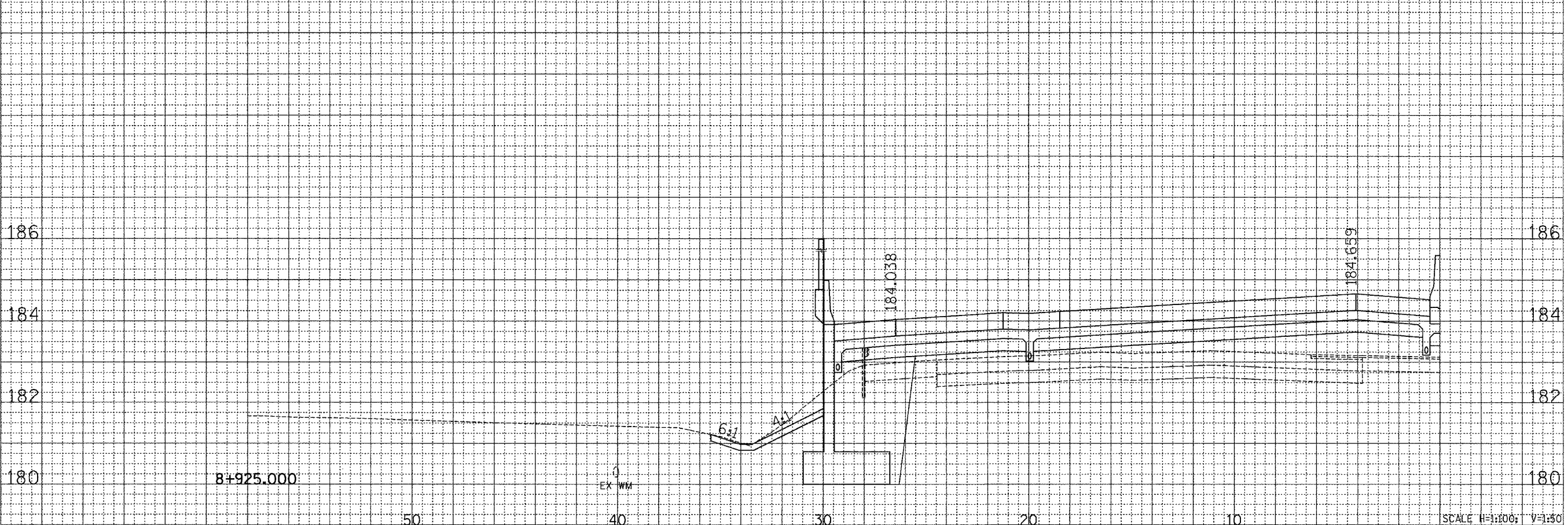

CROSS SECTION - I-80/94/US 6

...:\Sheets\18000\18000a.rds 09/14/2005 09:03:24 AM

C I-80

F.A.I. RTE.	SECTION	COUNTY	TOTAL SHEETS	SHEET NO.
80/94	2626.2-R-2	COOK	1207	1189
STA.		TO STA.		
FED. ROAD DIST. NO.		ILLINOIS	FED. AID PROJECT	
CONTRACT NO. 62114		INDOT DES. NO 0100987		

FINAL SURVEY	BY	DATE
SURVEYED		
NOTE BOOK		
NO.		
AREAS CHECKED		

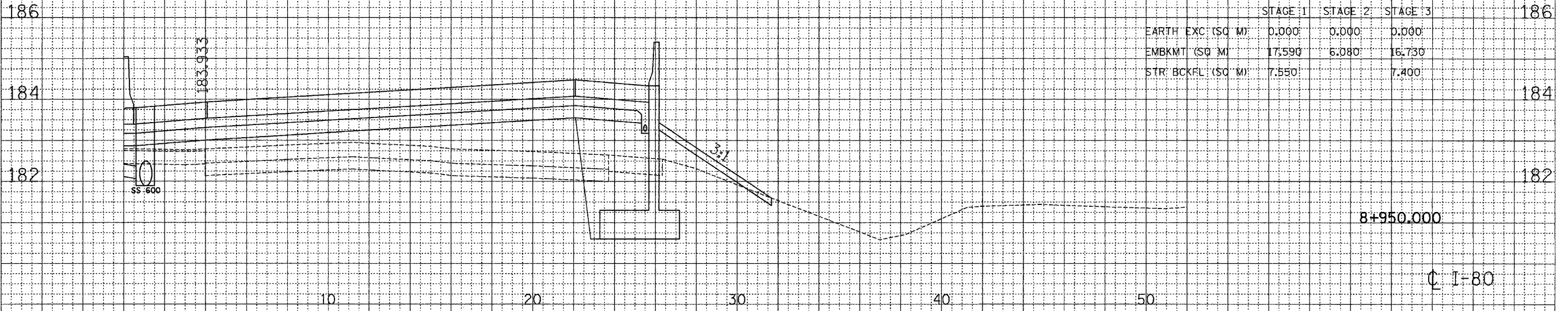

ORIGINAL SURVEY	BY	DATE
SURVEYED		
NOTE BOOK		
NO.		
AREAS CHECKED		

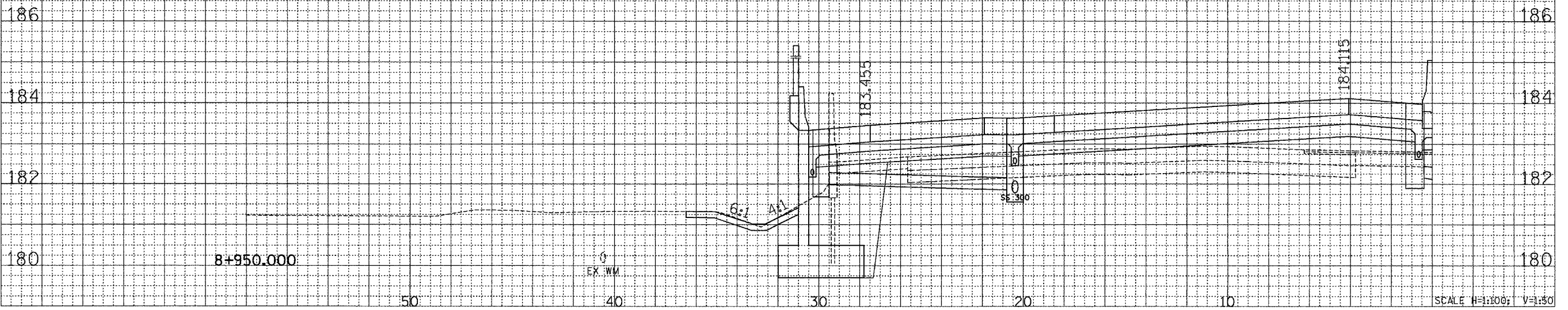

CROSS SECTION - I-80/94/US 6

... \SHP\414\EBR0018.rws 06/11/2005 09:03:31 AM

F.A.I. RTE. 80/94	SECTION 2626.2-R-2	COUNTY COOK	TOTAL SHEETS 1207	SHEET NO. 1190
STA.		TO STA.		
FED. ROAD DIST. NO.		ILLINOIS	FED. AID PROJECT	
CONTRACT NO. 62114		INDOT DES. NO 0100987		

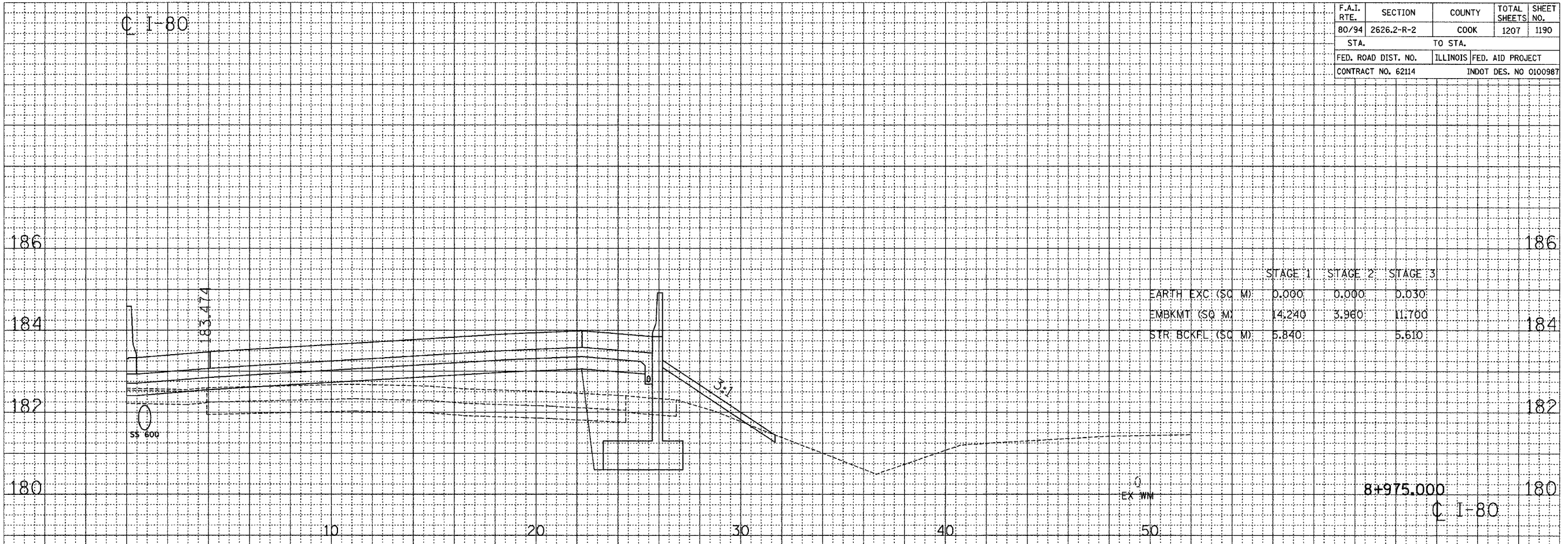

	STAGE 1	STAGE 2	STAGE 3
EARTH EXC (SQ M)	0.000	0.000	0.030
EMBKMT (SQ M)	14.240	3.960	11.700
STR. BCKFL (SQ M)	5.840		5.610

FINAL SURVEY	BY	DATE
NOTE BOOK NO.		
PLOTTED AREAS		
CHECKED AREAS		

ORIGINAL SURVEY	BY	DATE
NOTE BOOK NO.		
PLOTTED AREAS		
CHECKED AREAS		

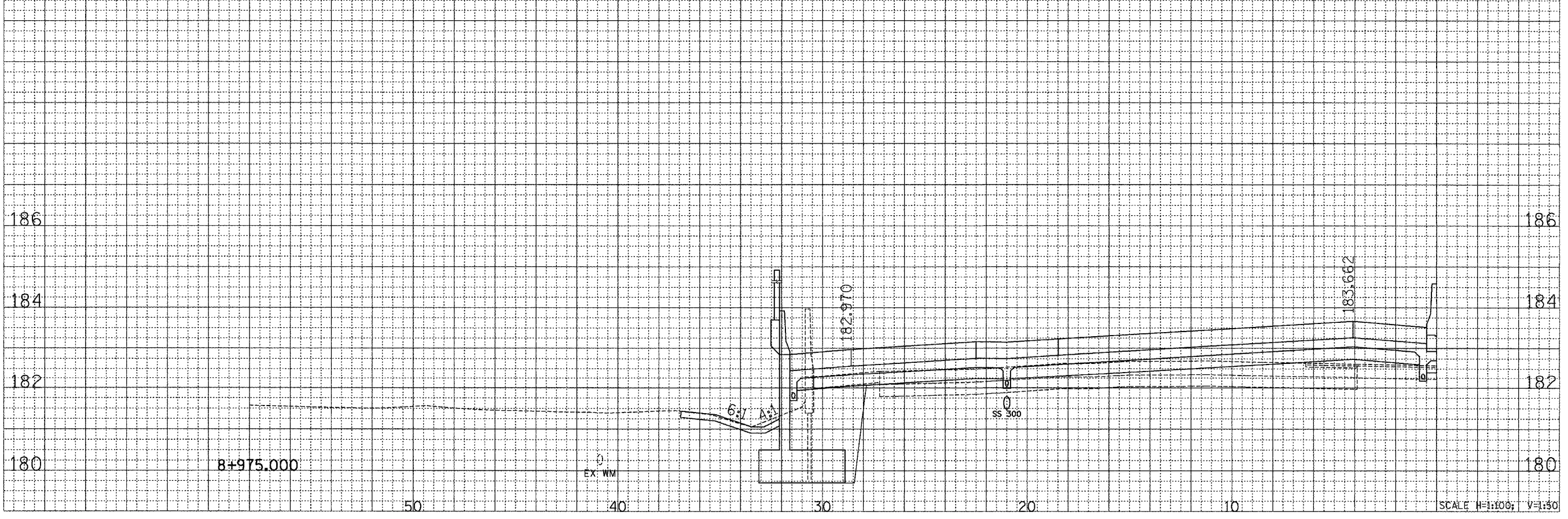

CROSS SECTION - I-80/94/US 6

SCALE H=1:100; V=1:50

F.A.I. RTE.	SECTION	COUNTY	TOTAL SHEETS	SHEET NO.
80/94	2626.2-R-2	COOK	1207	1191
STA.		TO STA.		
FED. ROAD DIST. NO.		ILLINOIS FED. AID PROJECT		
CONTRACT NO. 62114		INDOT DES. NO 0100987		

FINAL SURVEY	DATE
SURVEYED	
PLOTTED	
NOTE BOOK	
AREAS CHECKED	
NO.	

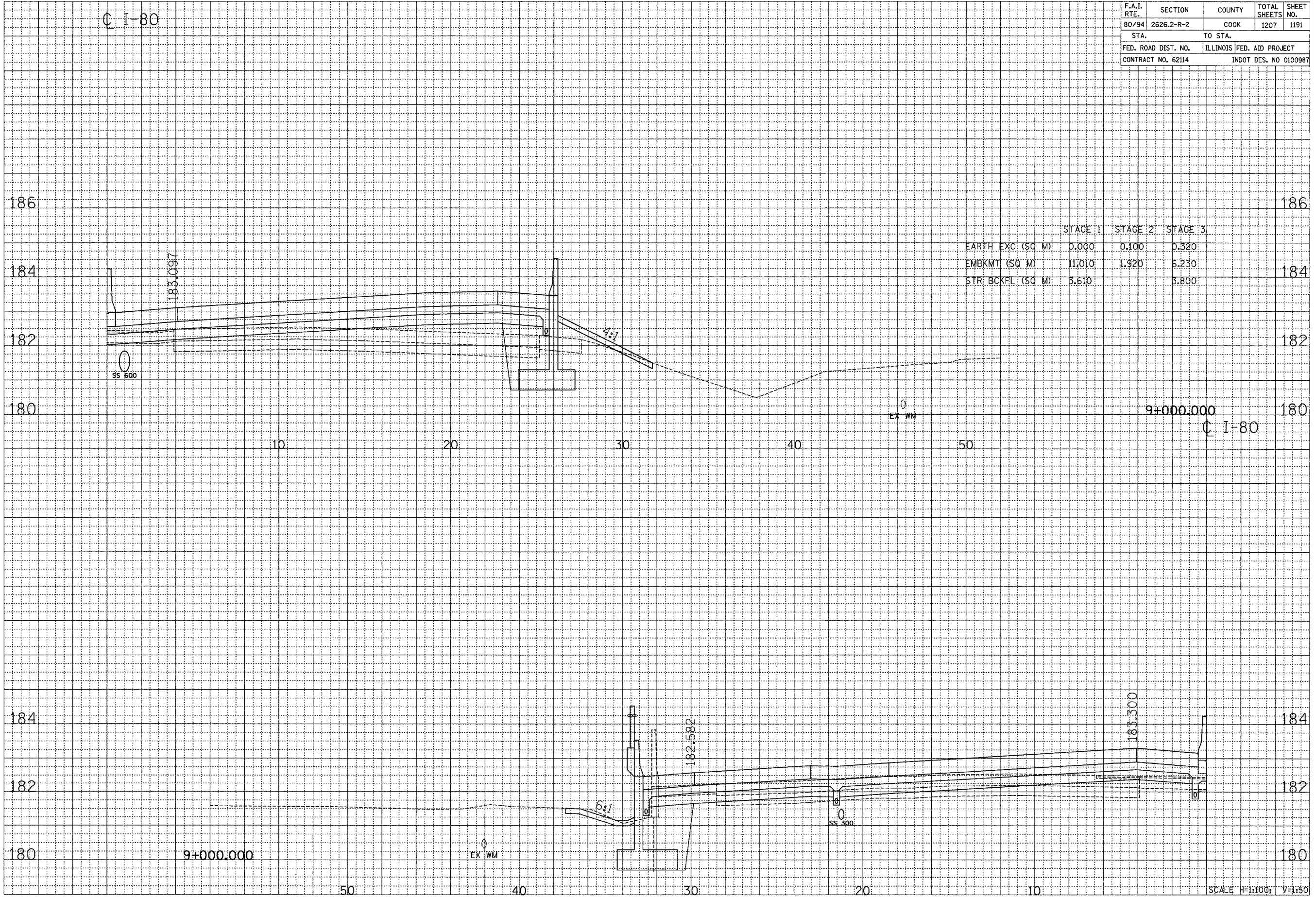

ORIGINAL SURVEY	DATE
SURVEYED	
PLOTTED	
NOTE BOOK	
AREAS CHECKED	
NO.	

CROSS SECTION - I-80/94/US 6

...:\Users\va190526-rdb_07/14/2005 08:13:47 AM

F.A.I. RTE.	SECTION	COUNTY	TOTAL SHEETS	SHEET NO.
80/94	2626.2-R-2	COOK	1207	1192
STA.		TO STA.		
FED. ROAD DIST. NO.		ILLINOIS	FED. AID PROJECT	
CONTRACT NO. 62114		INDOT DES. NO 0100987		

FINAL SURVEY	DATE
BY	
NO.	
AREAS CHECKED	
TEMP. AREAS	
NOTE BOOK	
NO.	

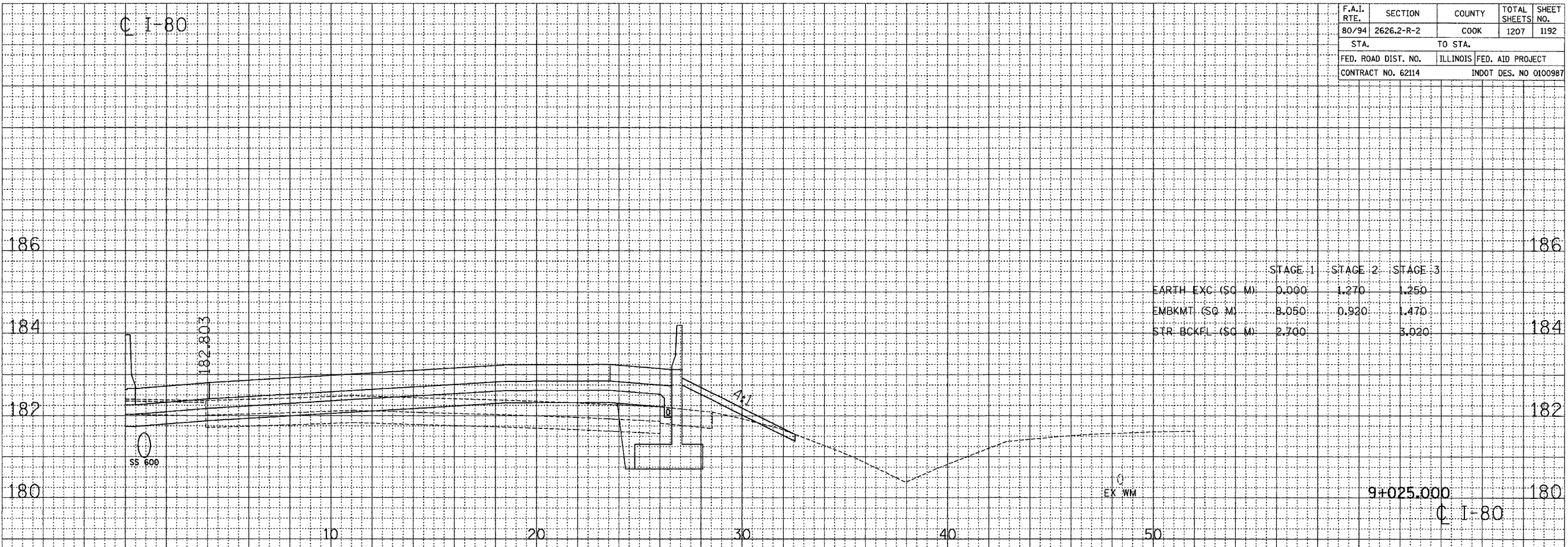

ORIGINAL SURVEY	DATE
BY	
NO.	
AREAS CHECKED	
TEMP. AREAS	
NOTE BOOK	
NO.	

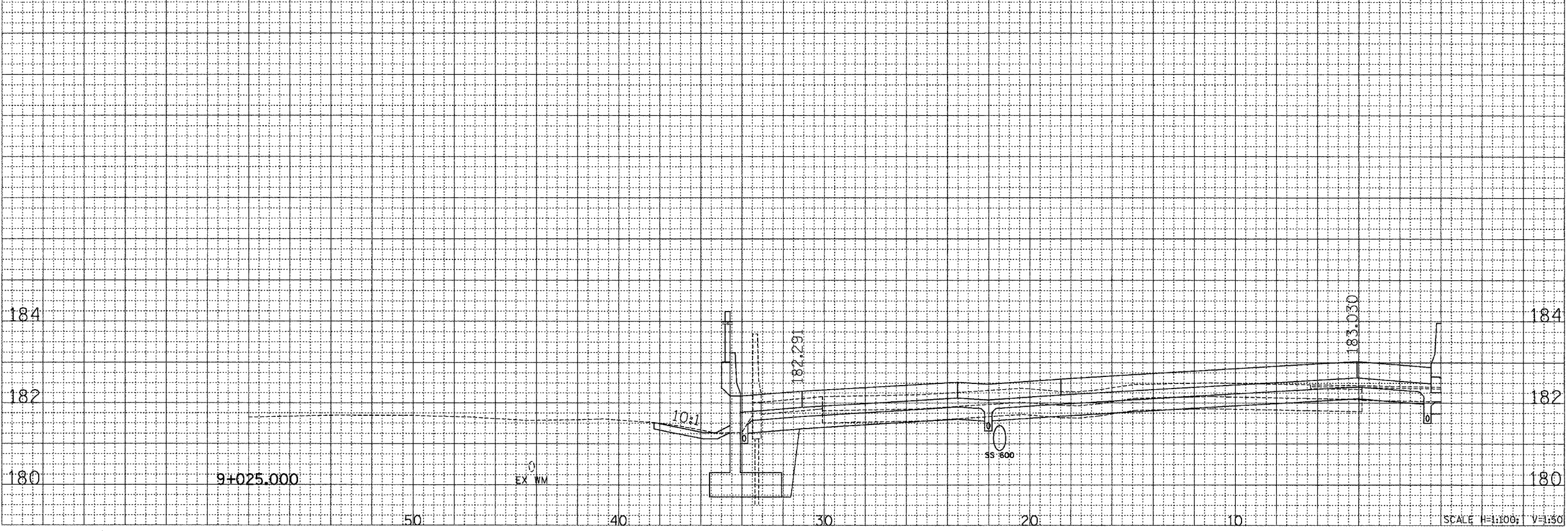

CROSS SECTION - I-80/94/US 6

...\\nfsa1446031a.ms 09/14/2005 09:01:55 AM

C I-80

F.A.I. RTE.	SECTION	COUNTY	TOTAL SHEETS	SHEET NO.
80/94	2626.2-R-2	COOK	1207	1193
STA.		TO STA.		
FED. ROAD DIST. NO.		ILLINOIS FED. AID PROJECT		
CONTRACT NO. 62114		INDOT DES. NO 0100987		

FINAL SURVEY	DATE
SURVEYED	
BY	
PLOTTED	
NOTE BOOK	
AREAS	
CHECKED	
NO.	

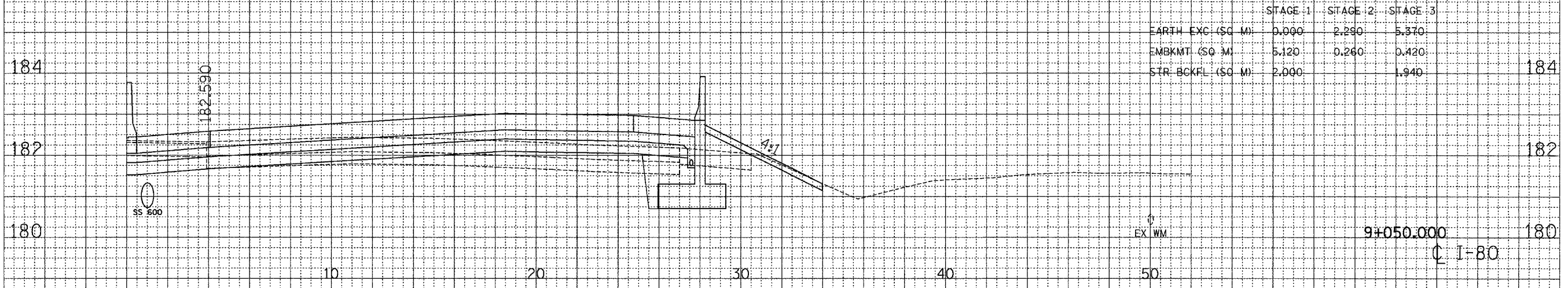

ORIGINAL SURVEY	DATE
SURVEYED	
BY	
PLOTTED	
NOTE BOOK	
AREAS	
CHECKED	
NO.	

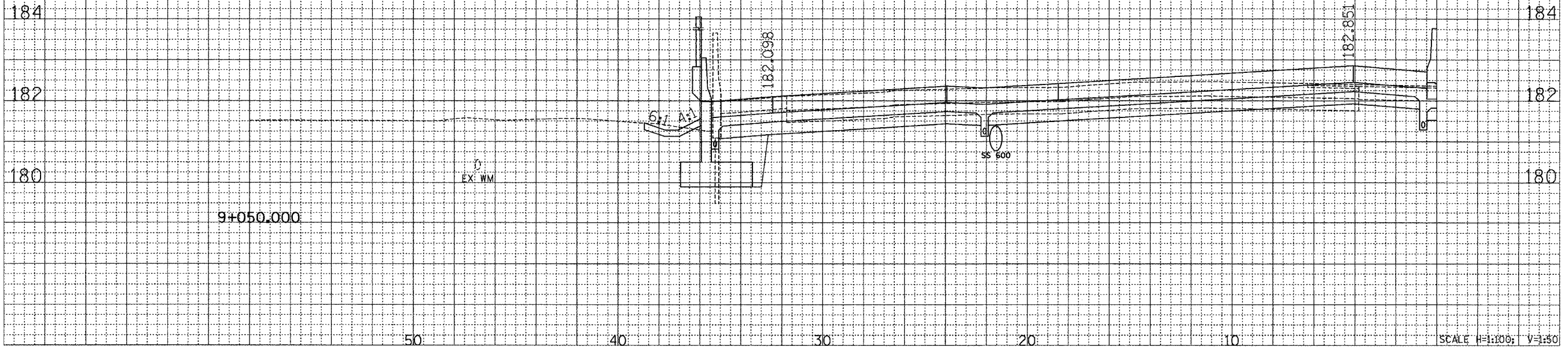

CROSS SECTION - I-80/94/US 6

SCALE H=1:100; V=1:50

...:iberev.us1600376.r66 03/14/2005 08:04:02 AM

F.A.I. RTE.	SECTION	COUNTY	TOTAL SHEETS	SHEET NO.
80/94	2626.2-R-2	COOK	1207	1194
STA.		TO STA.		
FED. ROAD DIST. NO.		ILLINOIS	FED. AID PROJECT	
CONTRACT NO. 62114		INDOT DES. NO 0100987		

FINAL SURVEY	BY	DATE
NOTE BOOK NO.		
AREAS CHECKED		

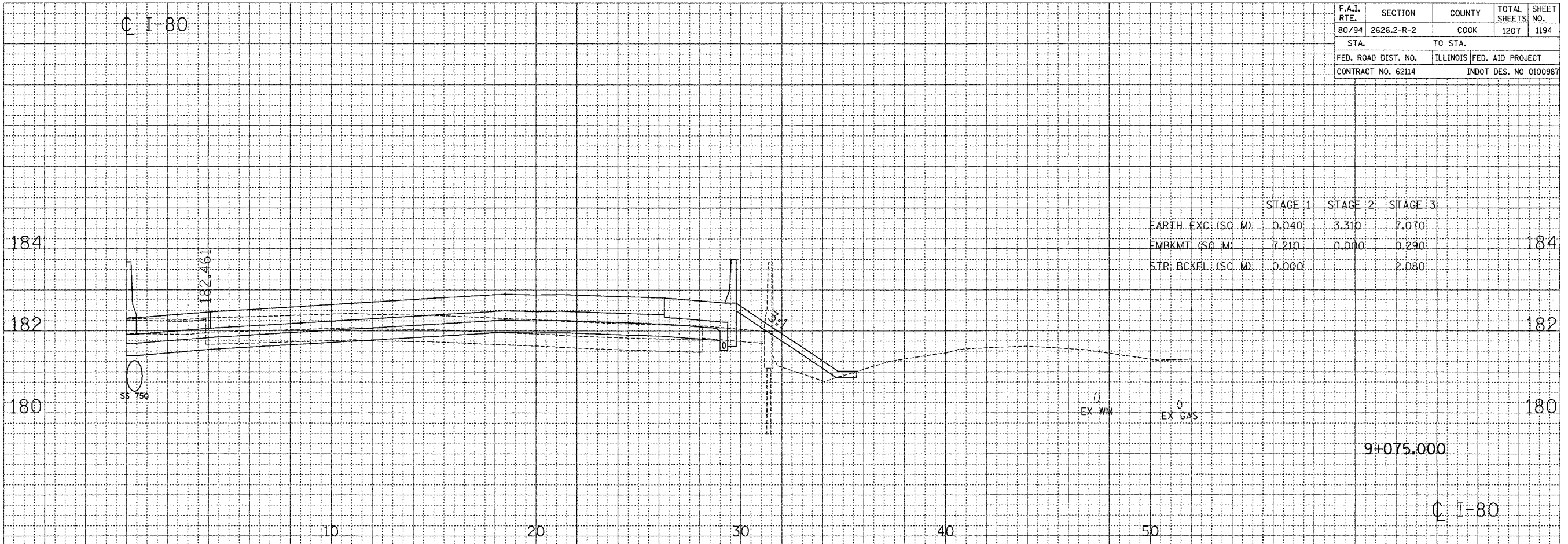

ORIGINAL SURVEY	BY	DATE
NOTE BOOK NO.		
AREAS CHECKED		

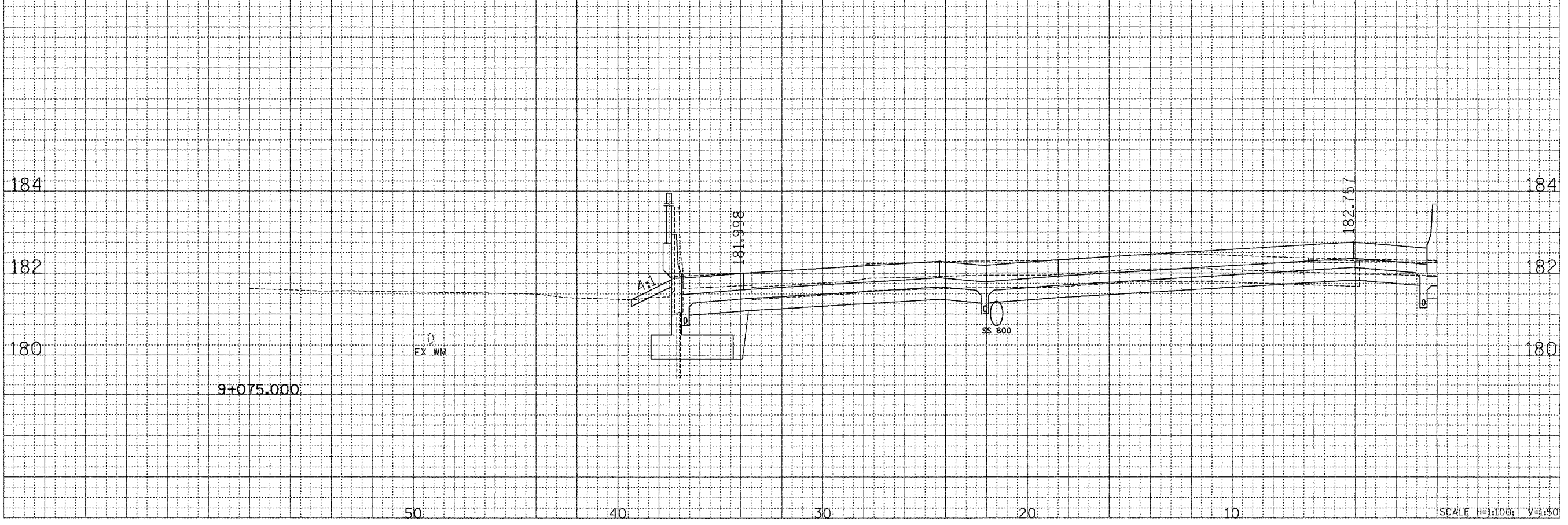

CROSS SECTION - I-80/94/US 6

Scale H=1:100; V=1:50

F.A.I. RTE. 80/94	SECTION 2626.2-R-2	COUNTY COOK	TOTAL SHEETS 1207	SHEET NO. 1195
STA.		TO STA.		
FED. ROAD DIST. NO.		ILLINOIS FED. AID PROJECT		
CONTRACT NO. 62114		INDOT DES. NO 0100987		

Q I-80

BY	DATE
FINAL SURVEY	
NOTED	
PLOTTED	
AREAS CHECKED	

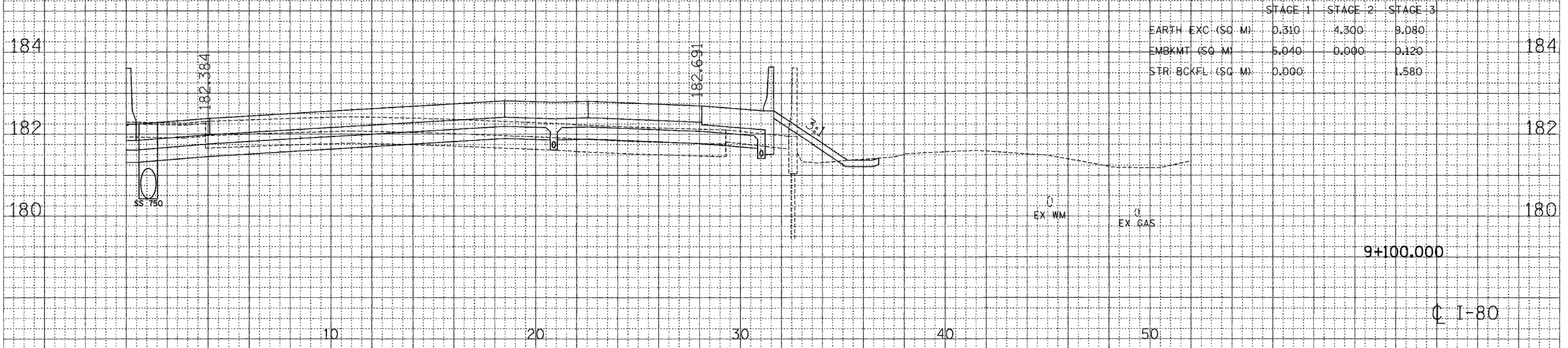

BY	DATE
ORIGINAL SURVEY	
NOTED	
PLOTTED	
AREAS CHECKED	

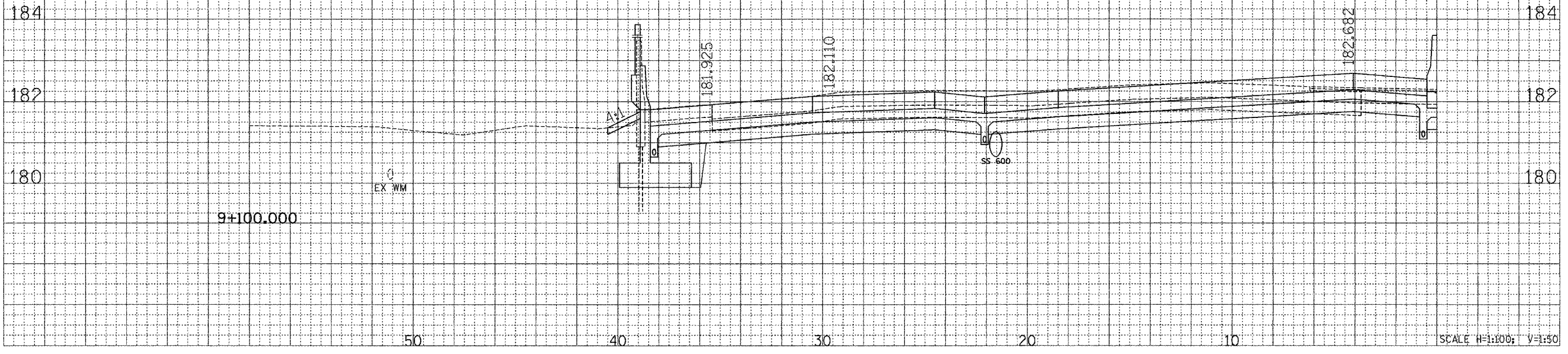

SCALE H=1:100; V=1:50
CROSS SECTION - I-80/94/US 6

...:\spreadsheets\000316.dwg 10/27/2005 03:36:35 PM

F.A.I. RTE.	SECTION	COUNTY	TOTAL SHEETS	SHEET NO.
80/94	2626.2-R-2	COOK	1207	1196
STA.		TO STA.		
FED. ROAD DIST. NO.		ILLINOIS FED. AID PROJECT		
CONTRACT NO. 62114		INDOT DES. NO 0100987		

FINAL SURVEY	BY	DATE
SURVEYED		
PLOTTED		
NOTE BOOK		
NO.		
AREAS CHECKED		

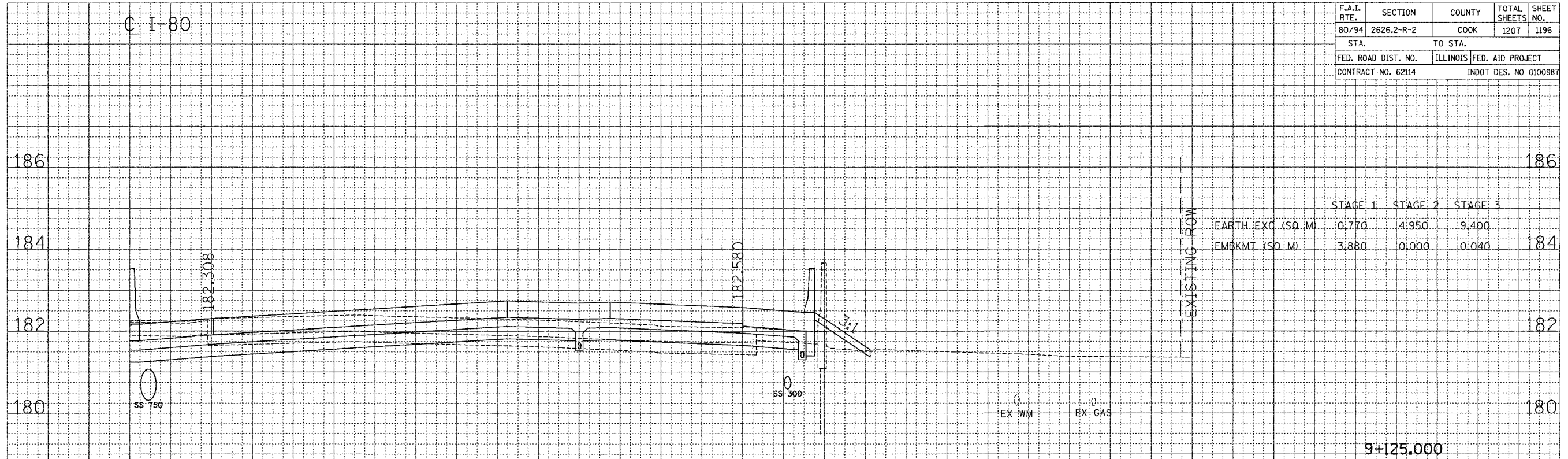

ORIGINAL SURVEY	BY	DATE
SURVEYED		
PLOTTED		
NOTE BOOK		
NO.		
AREAS CHECKED		

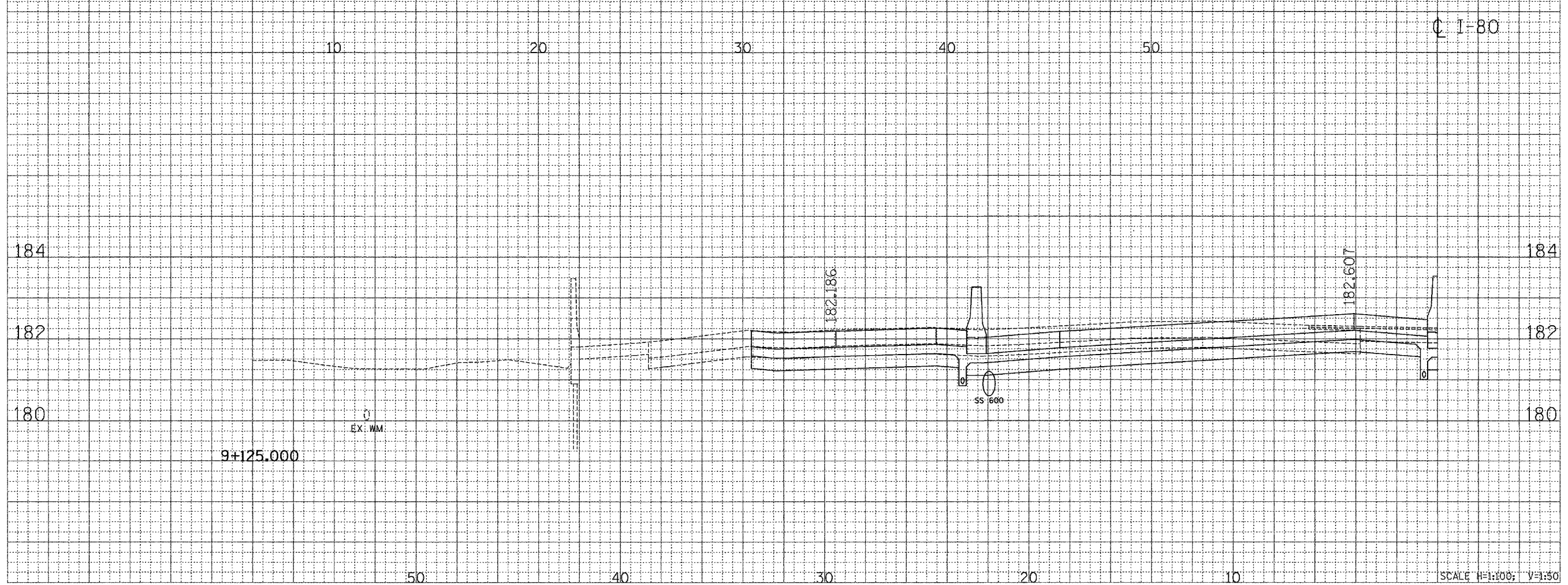

CROSS SECTION - I-80/94/US 6

Scale: H=1:100; V=1:50

F.A.I. RTE.	SECTION	COUNTY	TOTAL SHEETS	SHEET NO.
80/94	2626.2-R-2	COOK	1207	1197
STA.		TO STA.		
FED. ROAD DIST. NO.		ILLINOIS	FED. AID PROJECT	
CONTRACT NO. 62114		INDOT DES. NO 0100987		

FINAL SURVEY	BY	DATE
NOTED BOOK		
AREAS CHECKED		
NO.		

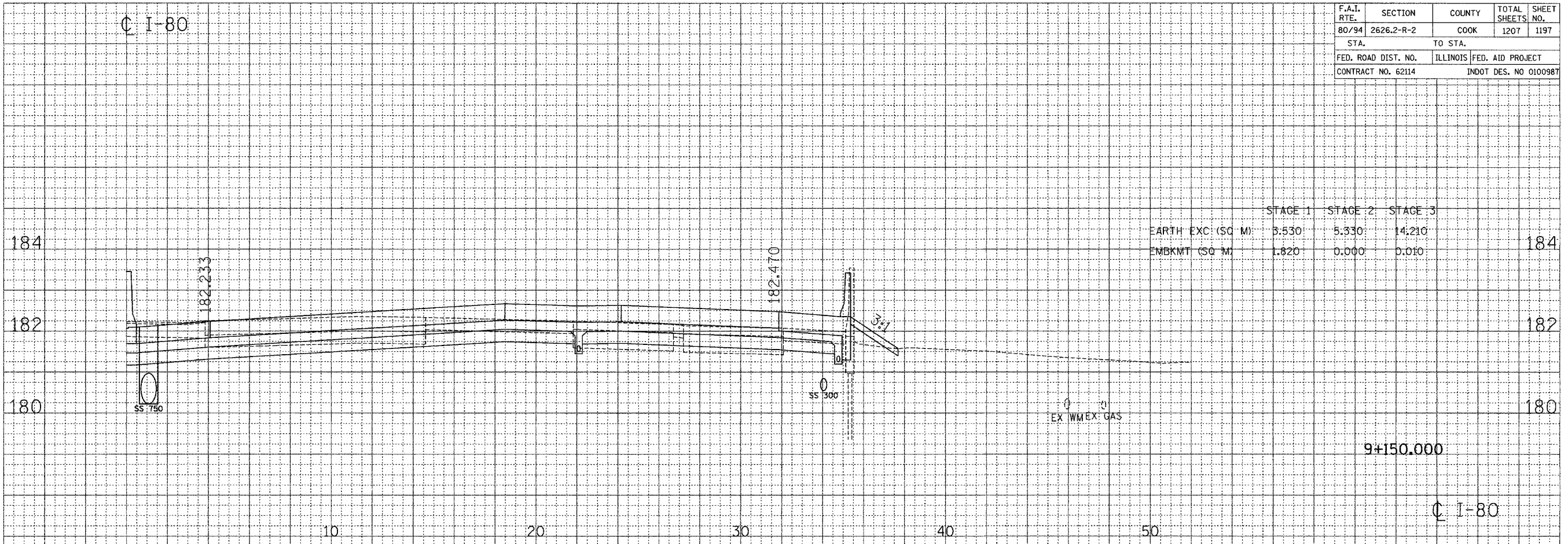

ORIGINAL SURVEY	BY	DATE
NOTED BOOK		
AREAS CHECKED		
NO.		

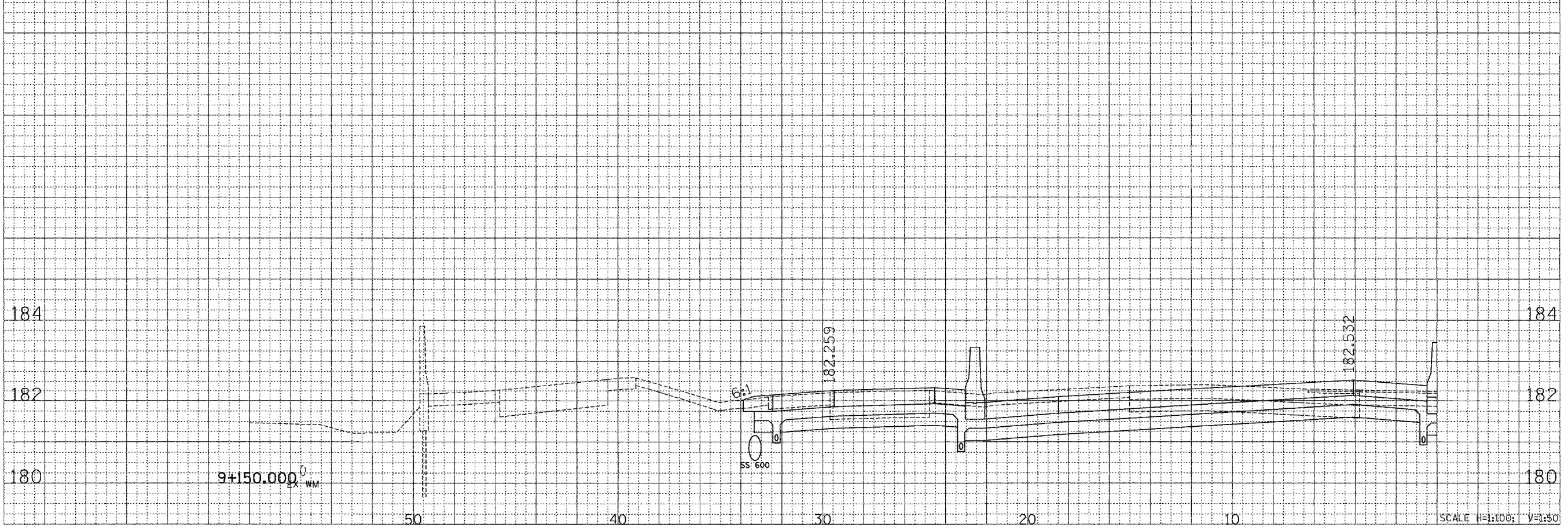

CROSS SECTION - I-80/94/US 6

Small vertical text at the bottom right corner, likely a file path or reference number.

F.A.I. RTE.	SECTION	COUNTY	TOTAL SHEETS	SHEET NO.
80/94	2626.2-R-2	COOK	1207	1198
STA.		TO STA.		
FED. ROAD DIST. NO.		ILLINOIS FED. AID PROJECT		
CONTRACT NO. 62114		INDOT DES. NO 0100987		

ORIGINAL SURVEY	DATE
SURVEYED	BY
PLOTTED	
NOTE BOOK	
AREAS	
CHECKED	

ORIGINAL SURVEY	DATE
SURVEYED	BY
PLOTTED	
NOTE BOOK	
AREAS	
CHECKED	

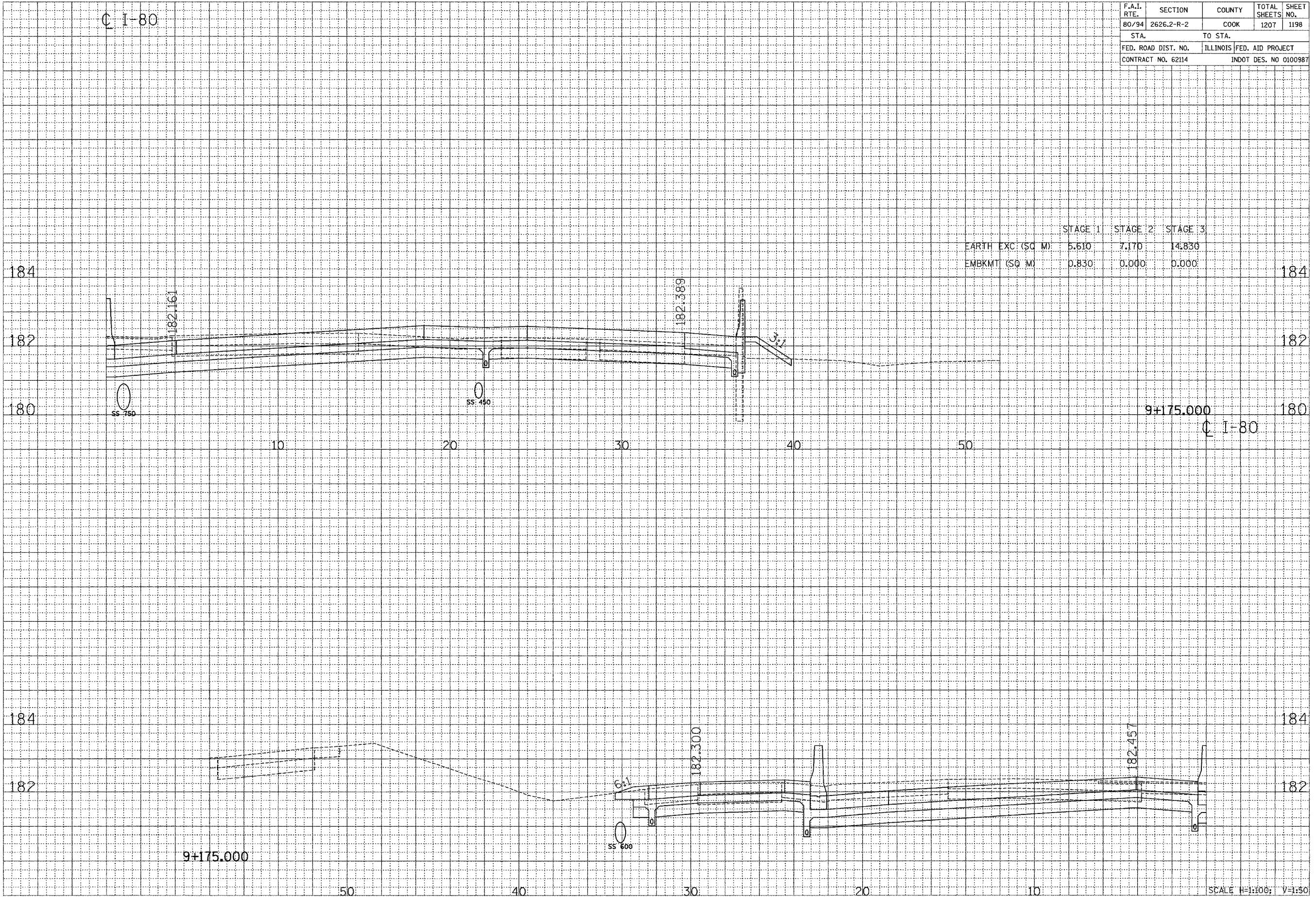

	STAGE 1	STAGE 2	STAGE 3
EARTH EXC (SQ M)	5.610	7.170	14.830
EMBKMT (SQ M)	0.830	0.000	0.000

CROSS SECTION - I-80/94/US 6

Scale: H=1:100; V=1:50

C I-80

F.A.I. RTE.	SECTION	COUNTY	TOTAL SHEETS	SHEET NO.
80/94	2626.2-R-2	COOK	1207	1199
STA.		TO STA.		
FED. ROAD DIST. NO.	ILLINOIS	FED. AID PROJECT		
CONTRACT NO. 62114	INDOT DES. NO 0100987			

FINAL SURVEY	DATE
NOTE BOOK NO.	
SURVEYED	BY
TEMPLATE	
AREAS CHECKED	

ORIGINAL SURVEY	DATE
NOTE BOOK NO.	
SURVEYED	BY
TEMPLATE	
AREAS CHECKED	

	STAGE 1	STAGE 2	STAGE 3	
EARTH. EXC. (SQ. M)	4.300	7.860	16.830	
EMBKMT. (SQ. M)	1.270	0.000	0.000	

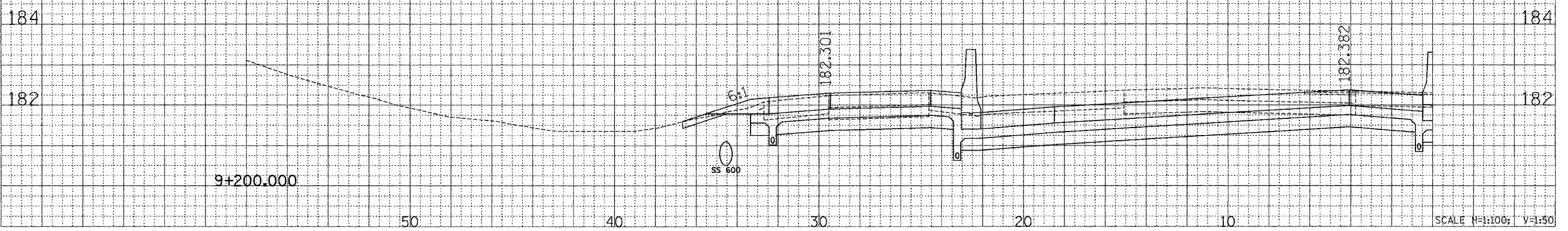
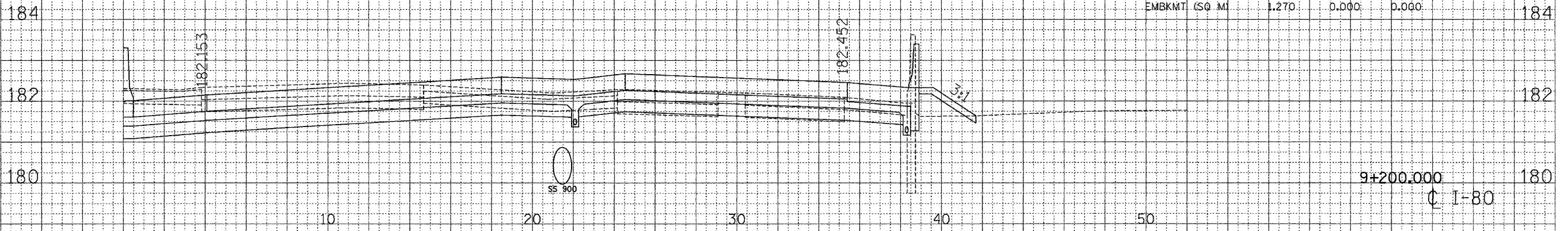

SCALE H=1:100; V=1:50

CROSS SECTION - I-80/94/US 6

C I-80

F.A.I. RTE.	SECTION	COUNTY	TOTAL SHEETS	SHEET NO.
80/94	2626.2-R-2	COOK	1207	1200
STA.		TO STA.		
FED. ROAD DIST. NO.		ILLINOIS FED. AID PROJECT		
CONTRACT NO. 62114		INDOT DES. NO 0100987		

FINAL SURVEY	BY	DATE
NOTED		
AREAS CHECKED		

ORIGINAL SURVEY	BY	DATE
NOTED		
AREAS CHECKED		

	STAGE 1	STAGE 2	STAGE 3	
EARTH EXC (SQ M)	5.680	7.160	19.100	
EMBKMT (SQ M)	0.510	0.000	0.000	184

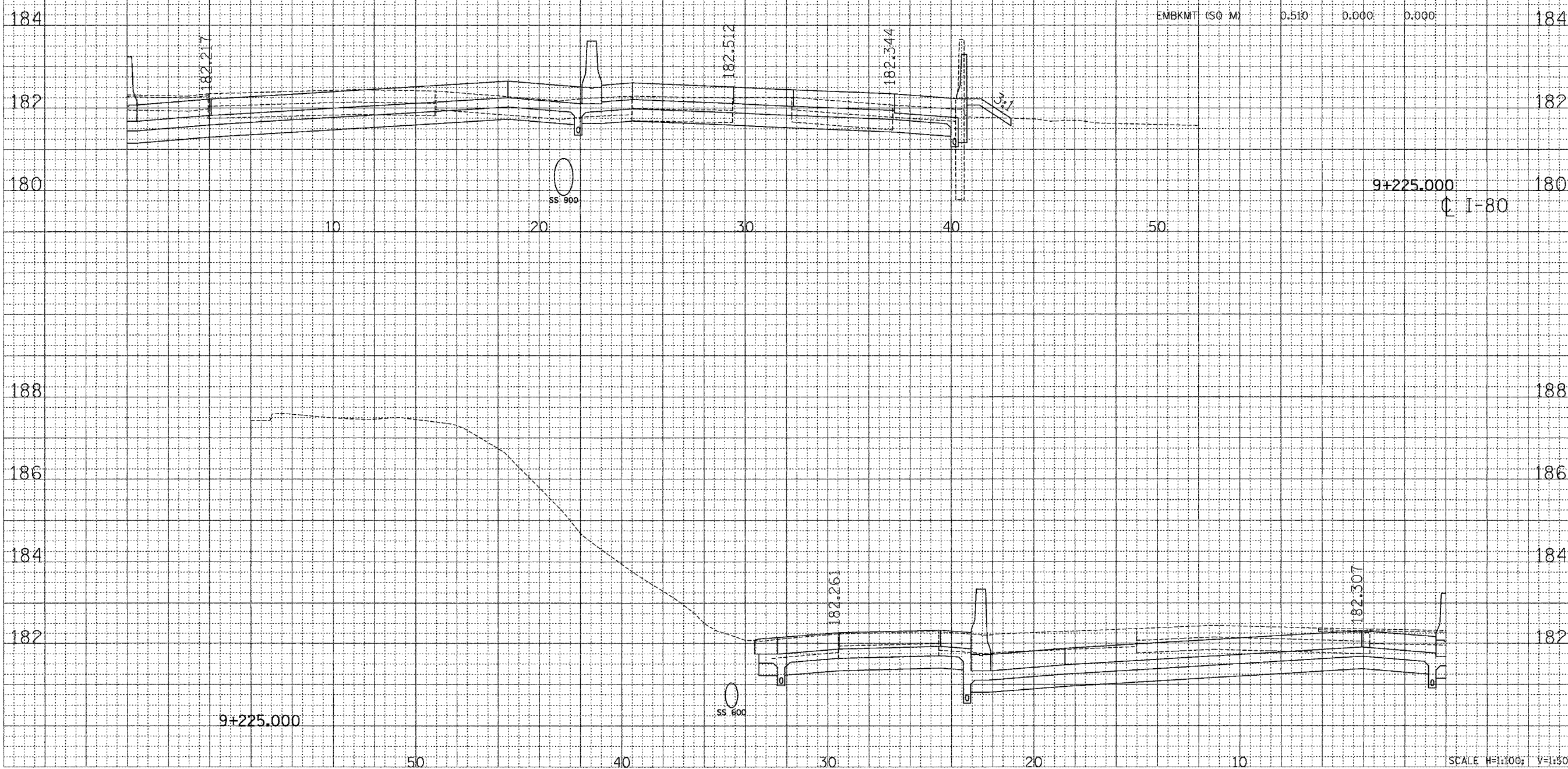

CROSS SECTION - I-80/94/US 6

08/27/2005 03:37:29 PM

C I-80

F.A.I. RTE.	SECTION	COUNTY	TOTAL SHEETS	SHEET NO.
80/94	2626.2-R-2	COOK	1207	1201
STA.		TO STA.		
FED. ROAD DIST. NO.		ILLINOIS	FED. AID PROJECT	
CONTRACT NO. 62114		INDOT DES. NO 0100987		

FINAL SURVEY	DATE
BY	
SWAYED SURVEY	
NOTE BOOK	
AREA	
AREAS CHECKED	

ORIGINAL SURVEY	DATE
BY	
SWAYED SURVEY	
NOTE BOOK	
AREA	
AREAS CHECKED	

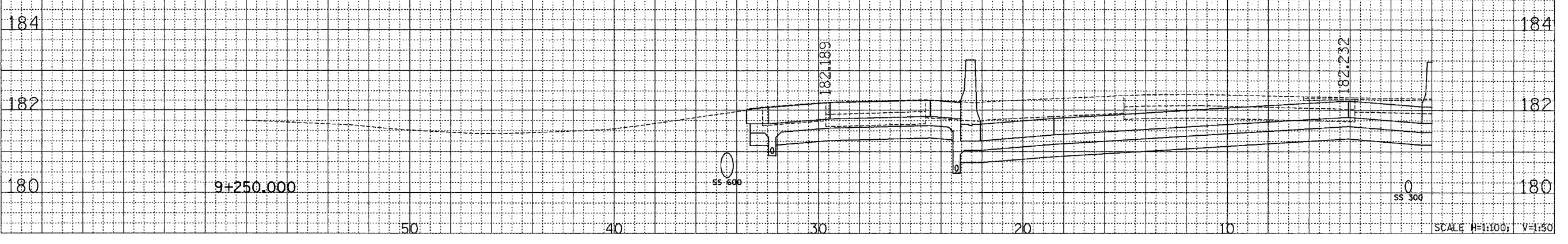
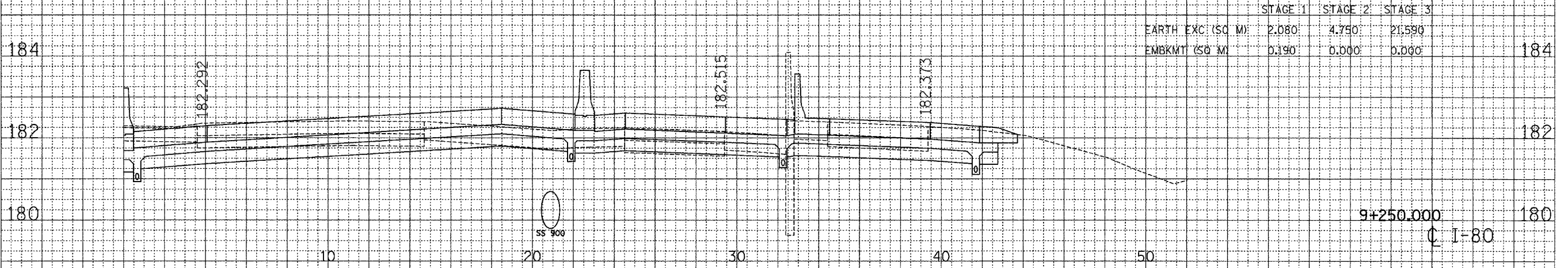

CROSS SECTION - I-80/94/US 6

...:\Swer\1\100218_05 06/12/2005 07:05:30 AM

F.A.I. RTE.	SECTION	COUNTY	TOTAL SHEETS	SHEET NO.
80/94	2626.2-R-2	COOK	1207	1202
STA.		TO STA.		
FED. ROAD DIST. NO.		ILLINOIS	FED. AID PROJECT	
CONTRACT NO. 62114		INDOT DES. NO 0100987		

FINAL SURVEY	DATE
BY	
ORIGINAL SURVEY	DATE
BY	
NOTE BOOK NO.	
AREAS CHECKED	

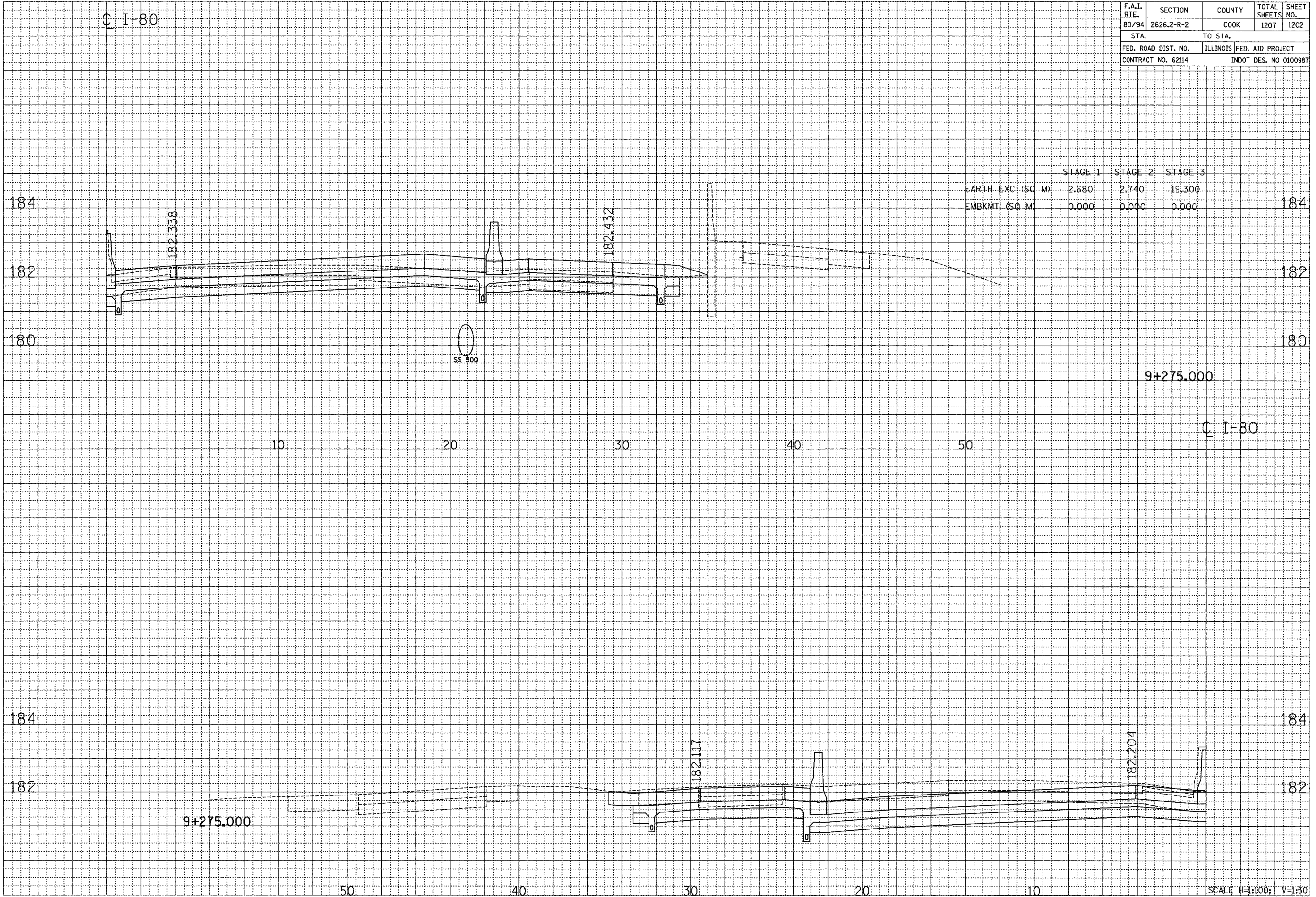

ORIGINAL SURVEY	DATE
BY	
NOTE BOOK NO.	
AREAS CHECKED	

CROSS SECTION - I-80/94/US 6

...:\bentley\us10031a.rvt: 05/12/2005 07:09:30 AM

F.A.I. RTE.	SECTION	COUNTY	TOTAL SHEETS	SHEET NO.
80/94	2626.2-R-2	COOK	1207	1203
STA.		TO STA.		
FED. ROAD DIST. NO.		ILLINOIS	FED. AID PROJECT	
CONTRACT NO. 62114		INDOT DES. NO 0100987		

FINAL SURVEY	DATE
SURVEYED	BY
NOTE BOOK	
NO.	
AREAS CHECKED	

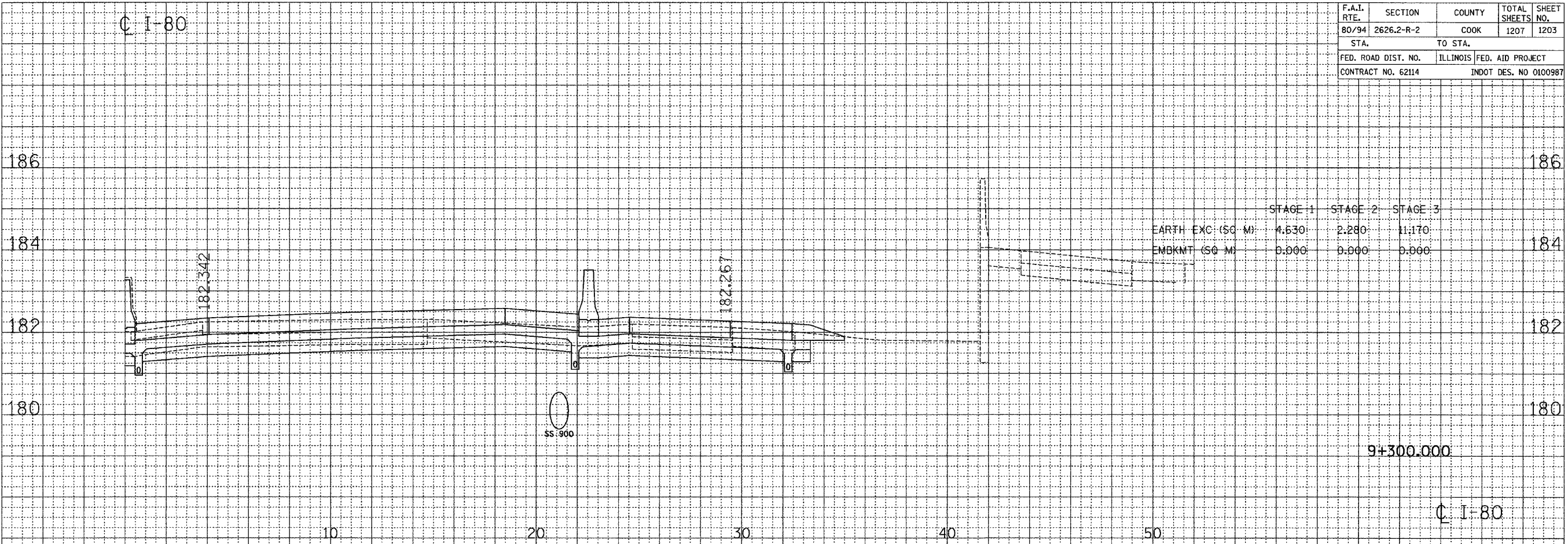

ORIGINAL SURVEY	DATE
SURVEYED	BY
NOTE BOOK	
NO.	
AREAS CHECKED	

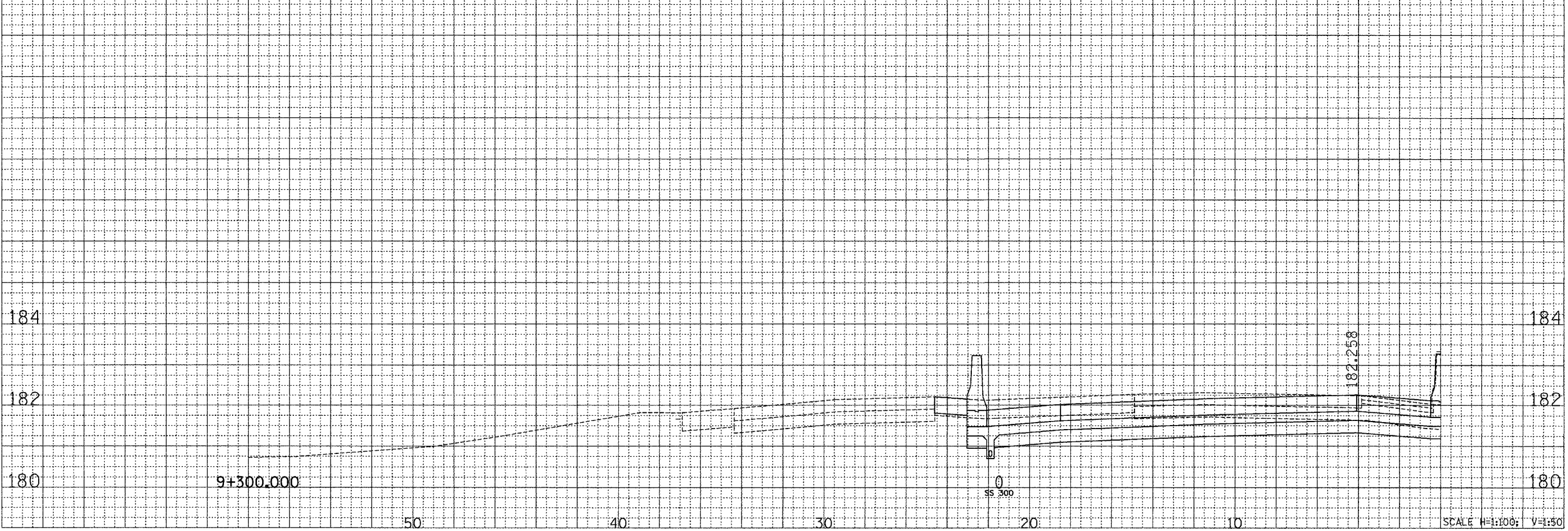

CROSS SECTION - I-80/94/US 6

\\snc\va310031a_r06 06/12/2009 07:15:54 AM

F.A.I. RTE. 80/94	SECTION 2626.2-R-2	COUNTY COOK	TOTAL SHEETS 1207	SHEET NO. 1204
STA.		TO STA.		
FED. ROAD DIST. NO.		ILLINOIS FED. AID PROJECT		
CONTRACT NO. 62114		INDOT DES. NO 0100987		

BY	DATE
FINAL SURVEY	SURVEYED
NOTE BOOK NO.	PLOTTED DATE
	AREAS CHECKED

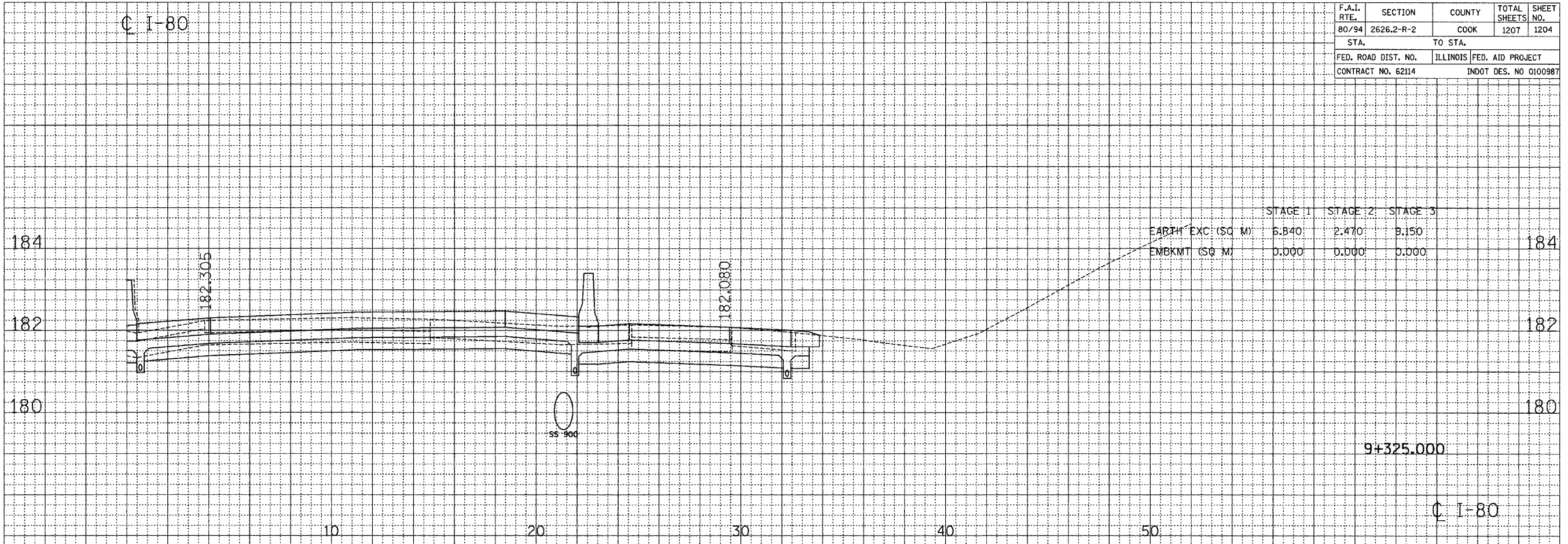

BY	DATE
ORIGINAL SURVEY	SURVEYED
NOTE BOOK NO.	PLOTTED DATE
	AREAS CHECKED

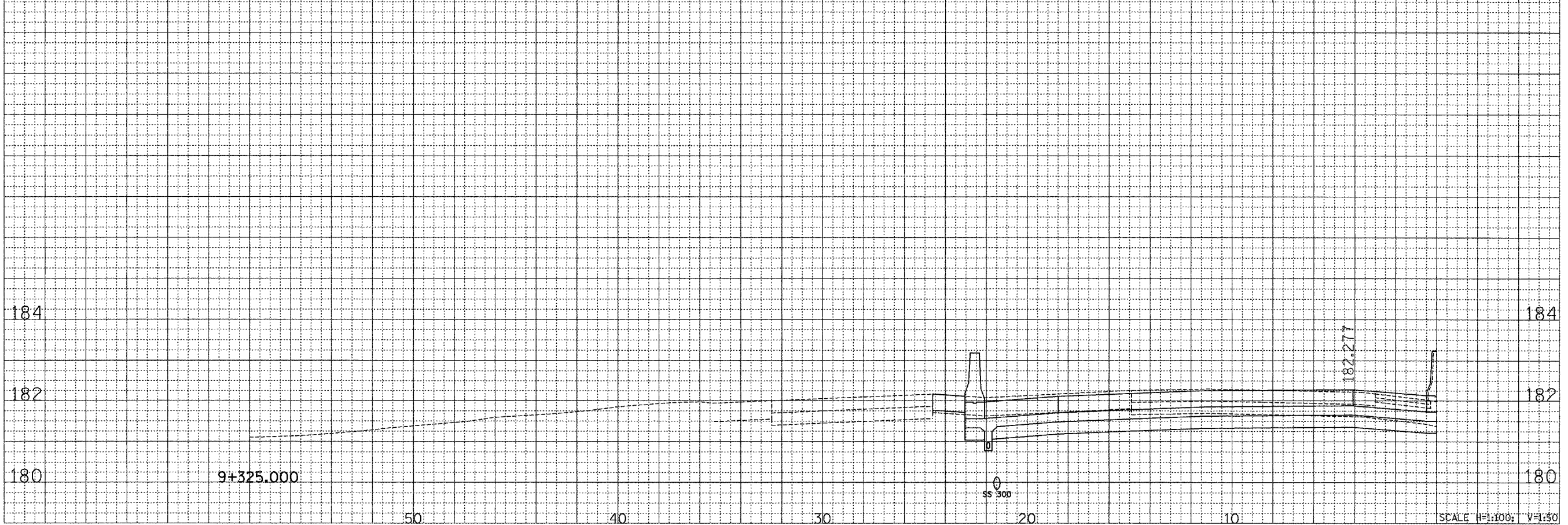

CROSS SECTION - I-80/94/US 6

...:\projects\62114\62114_115 06/12/2005 07:13:55 AM

F.A.I. RTE.	SECTION	COUNTY	TOTAL SHEETS	SHEET NO.
80/94	2626.2-R-2	COOK	1207	1205
STA.		TO STA.		
FED. ROAD DIST. NO.		ILLINOIS	FED. AID PROJECT	
CONTRACT NO. 62114		INDOT DES. NO 0100987		

DATE	BY
ORIGINAL SURVEY	DATE
PLOTTED	
NOTE BOOK	
AREAS	
CHECKED	

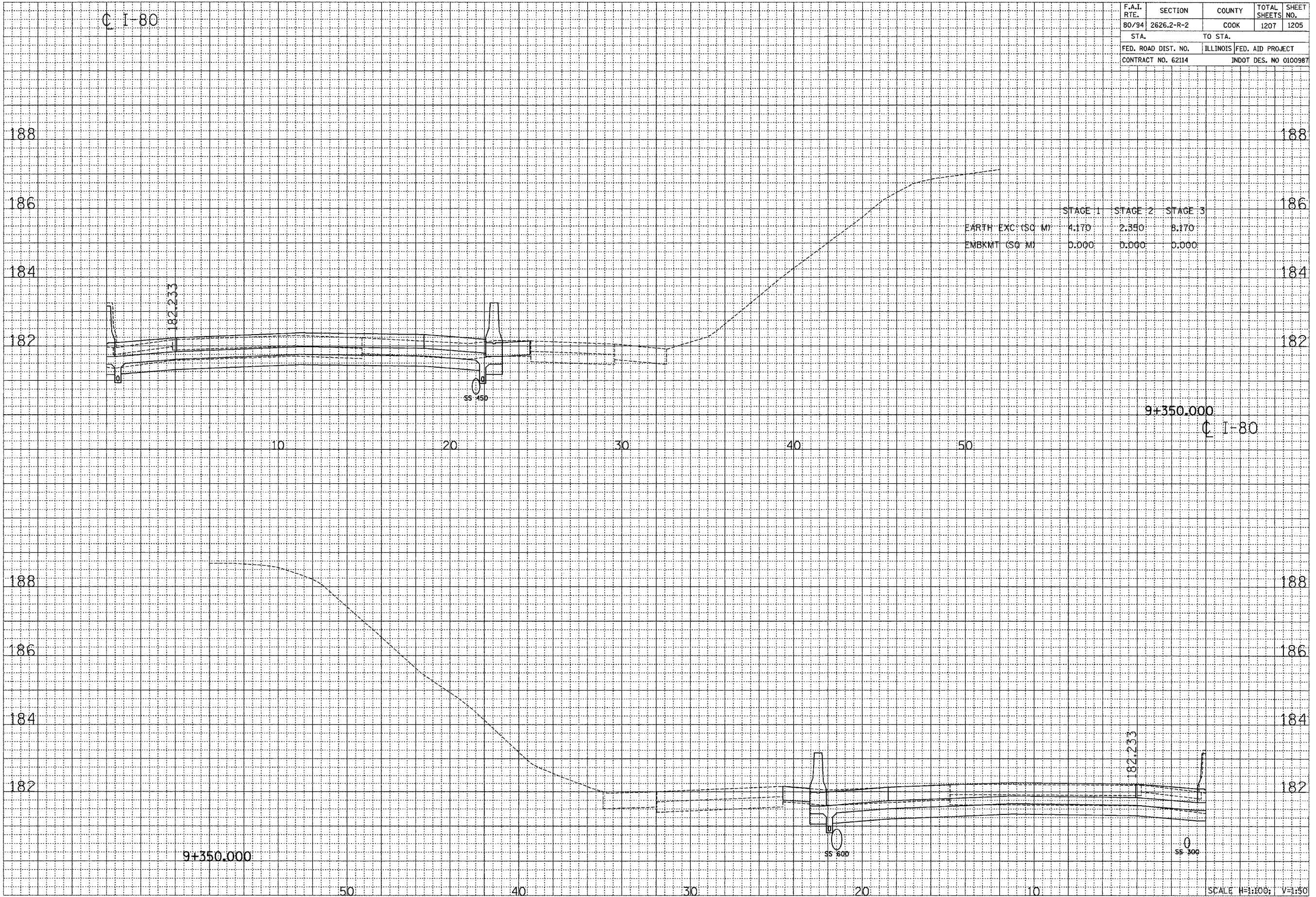

DATE	BY
ORIGINAL SURVEY	DATE
PLOTTED	
NOTE BOOK	
AREAS	
CHECKED	

CROSS SECTION - I-80/94/US 6

Scale: H=1:100; V=1:50

Q I-80

F.A.I. RTE.	SECTION	COUNTY	TOTAL SHEETS	SHEET NO.
80/94	2626.2-R-2	COOK	1207	1206
STA.		TO STA.		
FED. ROAD DIST. NO.		ILLINOIS FED. AID PROJECT		
CONTRACT NO. 62114		INDOT DES. NO 0100987		

BY	DATE
ORIGINAL SURVEY	SURVEYED
NOTE BOOK NO.	PLOTTED
	AREAS
	CHECKED

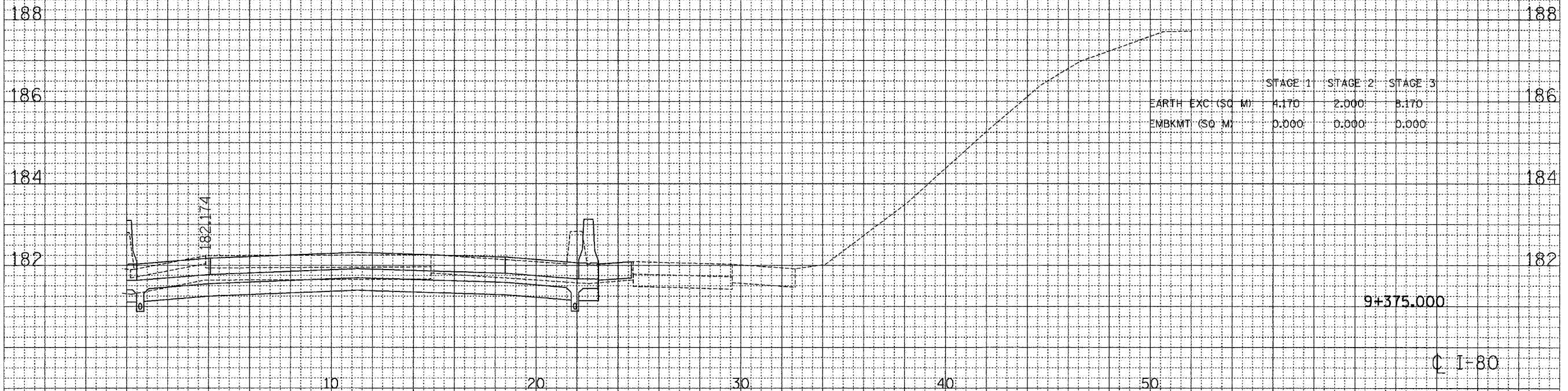

BY	DATE
ORIGINAL SURVEY	SURVEYED
NOTE BOOK NO.	PLOTTED
	AREAS
	CHECKED

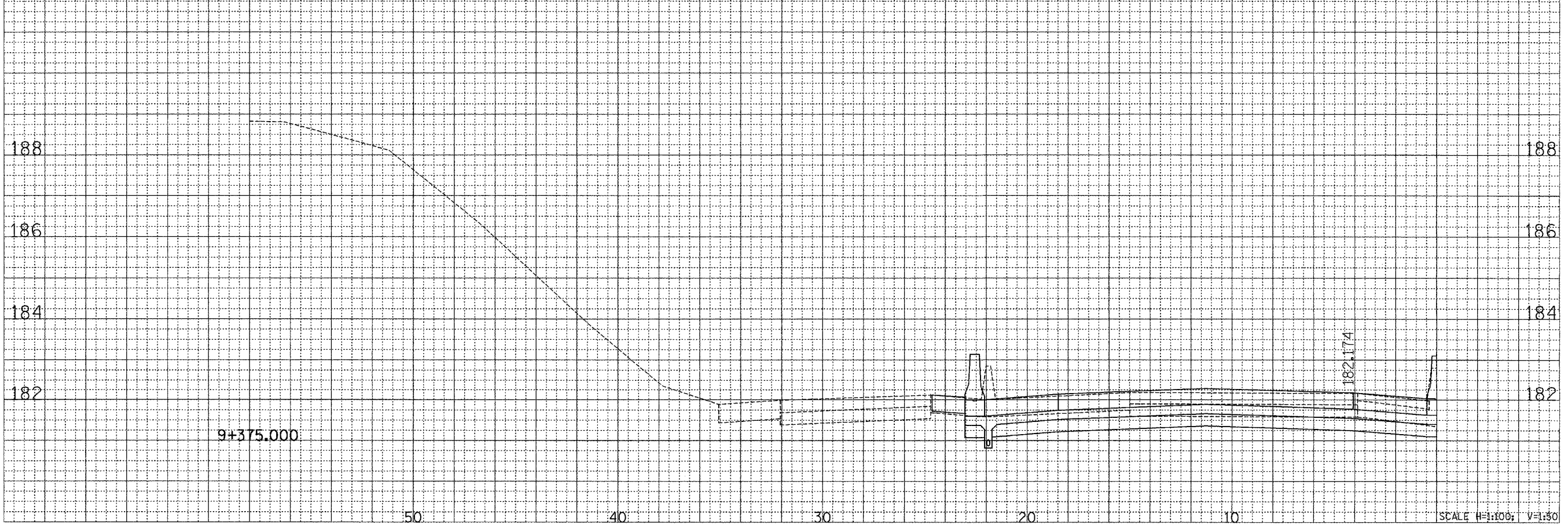

CROSS SECTION - I-80/94/US 6

Scale H=1:100; V=1:50

