

F.A. DIST.	SECTION	COUNTY	TOTAL SHEETS	SHEET NO.
301		STENHEIM	290	127
STA.	TO STA.			
FED. ROAD DIST. NO. 2	BALDWIN	FED. AID PROJECT		

BEVELED PIPE & GUARD DETAIL

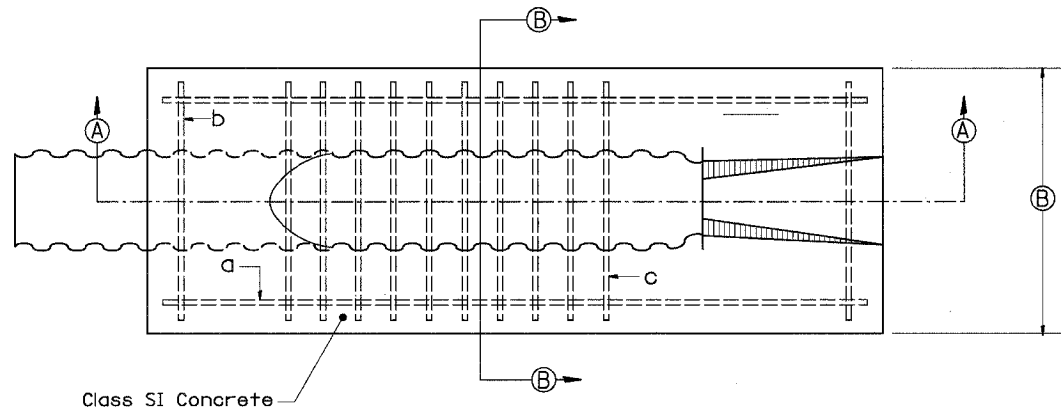

PLAN VIEW

Mark Req'd	Size	Length	No.
a	15 (5)	2750 (110)	2
b	15 (5)	800 (32)	2
c	25 (8)	850 (34)	10

Mark Req'd	Size	Length	No.
a	15 (5)	3400 (136)	2
b	15 (5)	875 (35)	2
c	25 (8)	925 (37)	14

Mark Req'd	Size	Length	No.
a	15 (5)	4050 (162)	2
b	15 (5)	950 (38)	2
c	25 (8)	1000 (40)	18

GENERAL NOTES:

Details shown hereon are for the construction of beveled pipe and guard. Alternate designs, methods of construction or materials may be submitted to the Engineer for approval. All methods of construction and materials involved shall conform to current Standard Specifications.

Reinforcing steel used in construction of "Beveled Pipe and Guard" shall be deformed bars meeting the requirements of Article 1006.10 of the Standard Specifications. All steel bars shall be hot-dip galvanized in accordance with ASTM A 123 specifications.

Concrete used in construction of the beveled pipe and guard shall be Class "SI" Concrete.

The corrugated metal pipe shall be cut to fit the 1:8 foreslope. Slots shall be cut into the C.M.P. for placement of the No. 25 (8) bars. After the foreslope has been placed, the No. 25 (8) bars shall be fitted into the slots cut in the C.M.P. so they will be in proper position when the concrete collar is poured.

This work shall be paid for at the contract unit price per Each for "Beveled Pipe and Guard", as shown hereon and as directed by the Engineer.

SPECIAL NOTE:

A silt basin will be required immediately upstream from the inlet of culvert. Refer to State Standard 280001 for construction details.

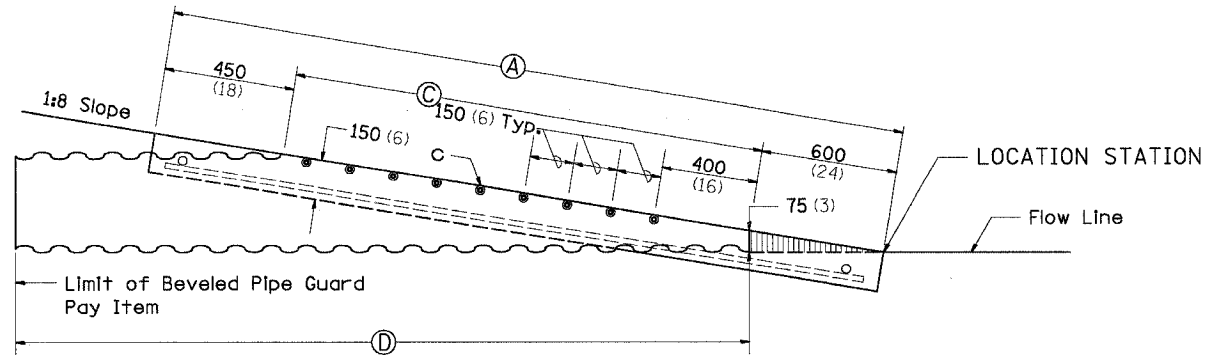

SECTION A-A

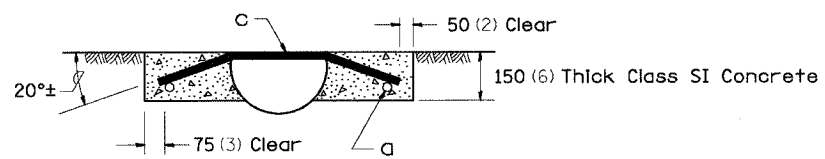

SECTION B-B

PIPE SIZE	A	B	C	D
305 (12)	2.9m (9'-6")	900 (36)	1.83m (6')	3m (10')
381 (15)	3.6m (11'-8")	975 (39)	2.5m (8'-2")	3.6m (12')
457 (18)	4.2m (13'-10")	1050 (42)	3.15m (10'-4")	4.5m (14'-10")

ALL DIMENSIONS ARE IN MILLIMETERS (INCHES) UNLESS OTHERWISE NOTED.

DATE-TIME
 10/26/2005 11:24:43 AM