

F. A. P. RTE.	SECTION	COUNTY	TOTAL SHEETS	SHEET NO.
301	*	**	290	128
STA.	TO STA.			
FED. ROAD DIST. NO. 2	B.LINER	FED. AID PROJECT		
* 177-3, 4, 4-1-1		** STEPHENSON		

(VARIES 51.5'-54') MEDIAN CROSSOVER

GENERAL NOTES

The intent of this plan is to show the construction requirements for a median crossover where the median width varies from 51.5' - 54'. Construction of median crossover shall conform to the requirement of current Standard Specifications. Slotted drain shall be constructed of 14-gauge corrugated metal roadway pipe modified to accommodate slotted drain as shown. Price bid for contract items shall be considered full compensation for furnishing all necessary materials and labor to construct the median crossover as detailed herein.

- Quantities are:
- (1552 Sq Yds.) FURNISHED EXCAVATION
  - (1900 Tons) STABILIZED SUBBASE, 4"
  - (2550 Sq. Yds.) SUBBASE GRANULAR MATERIAL TYPE A
  - (220 Lin. Ft.) P.C.C. CONCRETE, (JOINTED) 250 (10)
  - (126 Lin. Ft.) 375 (15) PIPE CULVERT, CLASS D, TYPE 1
  - 2 EACH SLOTTED DRAIN 300 (12) with 150 (6) SLOT
  - 2 EACH BEVELED PIPE GUARD
  - (423 Tons) AGGREGATE SHOULDER TYPE A 150 (6)
- Incidental Items to Slotted Drain Flowable Mortar
- EARTHWORK QUANTITIES ARE ACCOUNTED FOR IN THE EARTHWORK SCHEDULE

Elbows, Tees and Caps shall be considered incidental to the Corrugated Metal Pipe. ALL DIMENSIONS ARE IN MILLIMETERS (INCHES) UNLESS OTHERWISE NOTED.

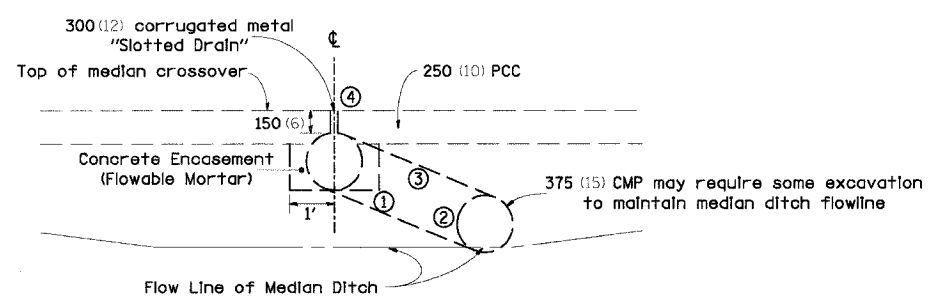

SECTION A-A

- ① 300 (12) CMP Elbow
- ② CMP Tee Section with 300 (12) Riser
- ③ 300 (12) Coupling Band
- ④ Duct tape or wood blocks shall be used to cover slotted drain during construction of crossover paving

		TABLE OF OFFSETS AND DROPS										
Distance meters (feet) from location station		(63.17)	(75)	(100)	(125)	(150)	(175)	(200)	(225)	(250)	(277.49)	
APPROACH 1	Offsets meters (feet) from inside edge of pavement	(25)	(23.00)	(21.34)	(18.12)	(15.33)	(12.94)	(10.96)	(9.38)	(7.90)	(6.78)	(6.00)
APPROACH 1	Drop meters (feet) from inside edge of pavement	(0.50)	(0.46)	(0.43)	(0.36)	(0.31)	(0.26)	(0.22)	(0.19)	(0.16)	(0.13)	(0.24)
APPROACH 2	Offsets meters (feet) from inside edge of pavement	(27)	(25.00)	(23.17)	(19.84)	(16.44)	(13.69)	(11.35)	(9.42)	(7.89)	(6.77)	(6.00)
APPROACH 2	Drop meters (feet) from inside edge of pavement	(0.54)	(0.50)	(0.46)	(0.40)	(0.33)	(0.27)	(0.23)	(0.19)	(0.16)	(0.14)	(0.24)
APPROACH 3	Offsets meters (feet) from inside edge of pavement	(26.5)	(24.50)	(22.69)	(19.18)	(16.09)	(13.40)	(11.12)	(9.24)	(7.77)	(6.71)	(6.00)
APPROACH 3	Drop meters (feet) from inside edge of pavement	(0.53)	(0.49)	(0.45)	(0.38)	(0.32)	(0.27)	(0.22)	(0.18)	(0.16)	(0.13)	(0.24)
APPROACH 4	Offsets meters (feet) from inside edge of pavement	(25)	(23.00)	(21.28)	(17.95)	(15.02)	(12.51)	(10.41)	(8.71)	(7.41)	(6.52)	(6.00)
APPROACH 4	Drop meters (feet) from inside edge of pavement	(0.50)	(0.46)	(0.43)	(0.36)	(0.30)	(0.25)	(0.21)	(0.17)	(0.15)	(0.13)	(0.24)

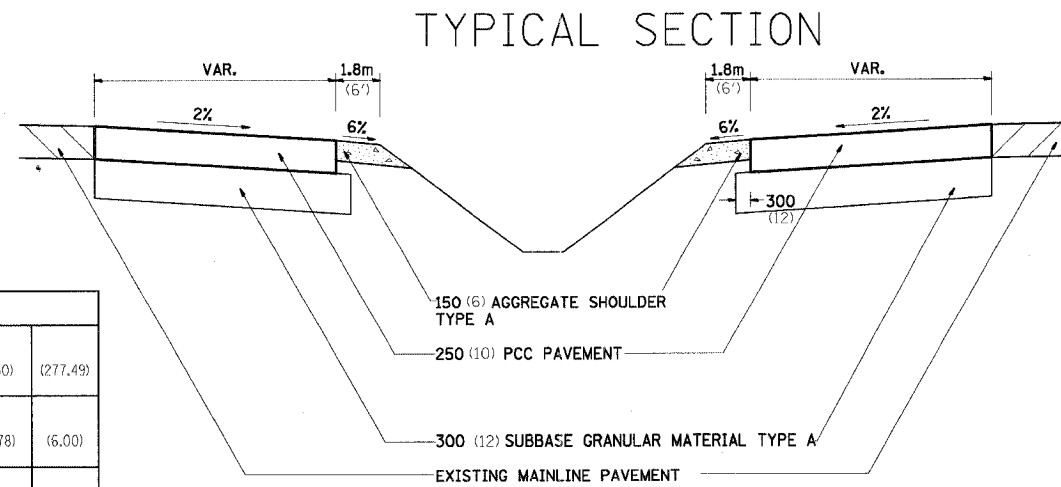

TYPICAL SECTION THRU CENTERLINE OF MEDIAN CROSSOVER

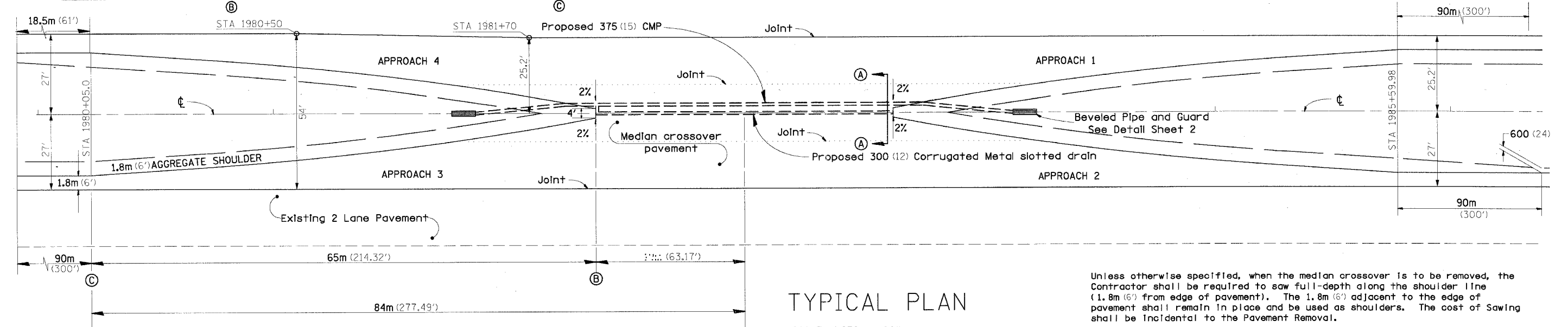
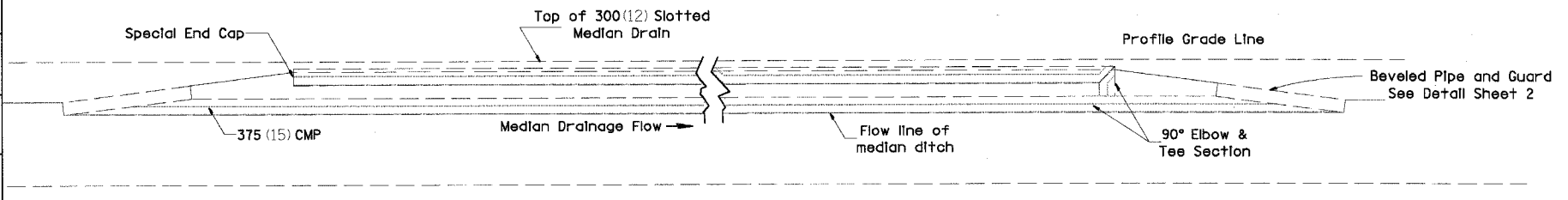

TYPICAL PLAN

SCALE= 1:250 (1"=20')

Unless otherwise specified, when the median crossover is to be removed, the Contractor shall be required to saw full-depth along the shoulder line (1.8m (6') from edge of pavement). The 1.8m (6') adjacent to the edge of pavement shall remain in place and be used as shoulders. The cost of Sawing shall be incidental to the Pavement Removal. Joints shall be sawed at 1/3 of the median width. All joints shall be sealed. TRAFFIC CONTROL STANDARD 701416 IS TO BE USED WITH THIS DETAIL

DATE-TIME  
 10/26/2005 12:16:55 PM