

CONTRACT NO. 72449

F.A.U. RTE.	SECTION	COUNTY	TOTAL SHEETS	SHEET NO.
*	**	SANGAMON	261	15
STA. ***		TO STA. ***		
FED. ROAD DIST. NO.	ILLINOIS	FED. AID PROJECT		

- 7978 (OLD US 36) & 7968 (CAMP BUTLER RD.)
- 3R(BR, BR-1, BR-2), 19RS-8
- E.B. OLD US 36 FR. STA 53+98.40 TO 58+44.40
- W.B. OLD US 36 FR. STA 56+68.30 TO 58+70.30

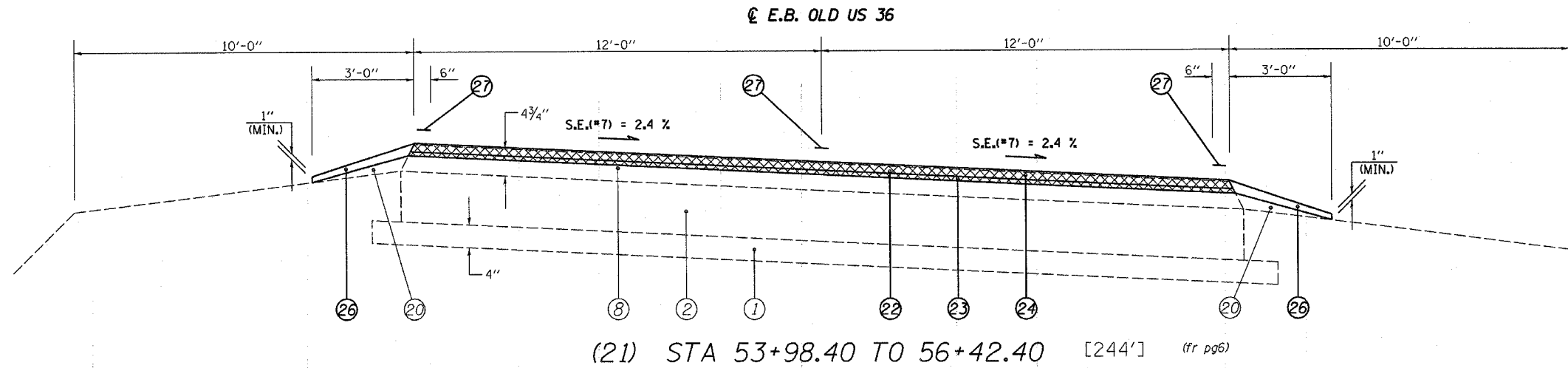

**FULL S.E.:** (S.E.#7 = 2.4%)  
 STA 54+80.40 TO 61+49.60  
**S.E. TRANSITION:**  
 STA 53+16.40 TO 54+80.40  
 STA 61+49.6 TO 63+13.60

(21) STA 53+98.40 TO 56+42.40 [244'] (fr pg6)

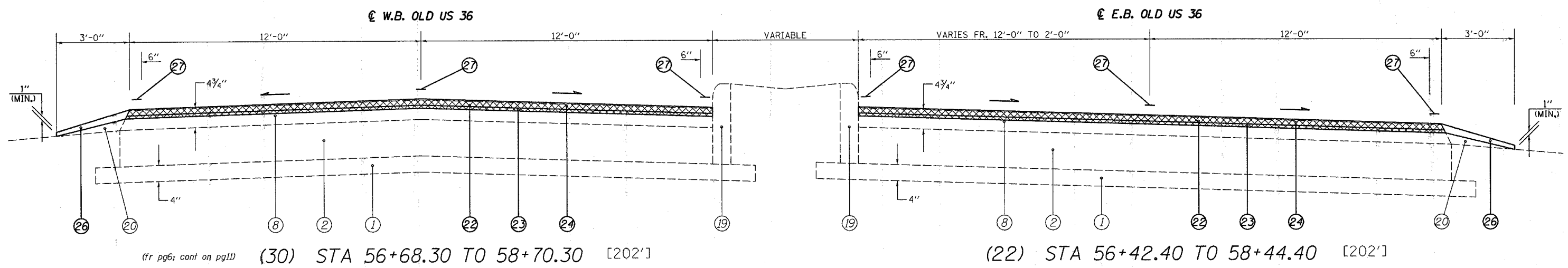

(fr pg6; cont on pg11)

(30) STA 56+68.30 TO 58+70.30 [202']

(22) STA 56+42.40 TO 58+44.40 [202']

**LEGEND**

- |   |  |
|---|--|
| ① EXIST. SUB-BASE GRANULAR MATERIAL               | ⑮ EXIST. P.C.C. CURB & GUTTER, TYPE 7                                      |
| ② EXIST. P.C.C. PAVEMENT 9"                       | ⑯ EXIST. P.C.C. CURB, TYPE 4   |
| ③ EXIST. P.C.C. PAVEMENT 9"-6"-9"                 | ⑰ EXIST. P.C.C. CURB, TYPE 10 (MODIFIED)                                   |
| ④ EXIST. P.C.C. PAVEMENT 10"                      | ⑱ EXIST. AGGREGATE SHOULDERS, TYPE B                                       |
| ⑤ EXIST. BITUMINOUS BASE COURSE 10"               | ⑲ PROP. BITUMINOUS SURFACE REMOVAL (VARIABLE DEPTH) *                      |
| ⑥ EXIST. P.C.C. BASE COURSE WIDENING 9"           | ⑳ PROP. BITUMINOUS SURFACE REMOVAL 2"                                      |
| ⑦ EXIST. STABILIZED BASE COURSE 10"               | ㉑ PROP. LEVELING BINDER (MACHINE METHOD), SUPERPAVE N70 3/4"               |
| ⑧ EXIST. BITUMINOUS OVERLAY                       | ㉒ PROP. BITUMINOUS CONCRETE SURFACE COURSE, SUPERPAVE, MIX "D", N70 1 1/2" |
| ⑨ EXIST. BITUMINOUS SHOULDERS                     | ㉓ PROP. BITUMINOUS SHOULDERS SUPERPAVE                                     |
| ⑩ EXIST. PIPE UNDERDRAIN 6"                       | ㉔ PROP. AGGREGATE SHOULDERS, TYPE B  |
| ⑪ EXIST. CONCRETE GUTTER, TYPE A (MODIFIED)       | ㉕ PROP. PAINT PAVEMENT MARKING - LINE 5"                                   |
| ⑫ EXIST. CONCRETE GUTTER, TYPE B                  | ㉖ PROP. CONCRETE GUTTER, TYPE A (MODIFIED)                                 |
| ⑬ EXIST. CONCRETE GUTTER, TYPE C (MODIFIED)       | ㉗ PROP. BITUMINOUS SHOULDER SUPERPAVE 8"                                   |
| ⑭ EXIST. P.C.C. CURB & GUTTER, TYPE 10 (MODIFIED) | ㉘ PROP. GRADING AND SHAPING SHOULDERS                                      |
| ⑮ EXIST. P.C.C. CURB & GUTTER, TYPE 6             |  |
| ⑯ EXIST. P.C.C. CURB & GUTTER, TYPE 6 (MODIFIED)  |  |

\* NOMINAL MILLING DEPTH 1/2"

NOT TO SCALE

REVISIONS	
NAME	DATE

ILLINOIS DEPARTMENT OF TRANSPORTATION  
**TYPICAL SECTIONS**  
 F.A.U. Route 7978 (OLD US 36) &  
 F.A.U. Route 7968 (CAMP BUTLER RD.)  
 Section 3R(BR, BR-1, BR-2), 19RS-8  
 SANGAMON COUNTY  
 SCALE: VERT. DRAWN BY: JWC  
 HORIZ. CHECKED BY: RSC  
 DATE: JULY 20, 2005

(W.B. & E.B. OLD US 36)

\*DEN-SPEC-  
\*DATE-TIME-  
\*REF-01