

CONTRACT NO. 72449

F.A.U. RTE.	SECTION	COUNTY	TOTAL SHEETS	SHEET NO.
•	••	SANGAMON	261	29
STA. 4+68.80		TO STA. 8+00.00		
FED. ROAD DIST. NO.		ILLINOIS FED. AID PROJECT		
• 7978 (OLD US 36) & 7968 (CAMP BUTLER RD.)				
•• 3R(BR, BR-1, BR-2), 19RS-8				

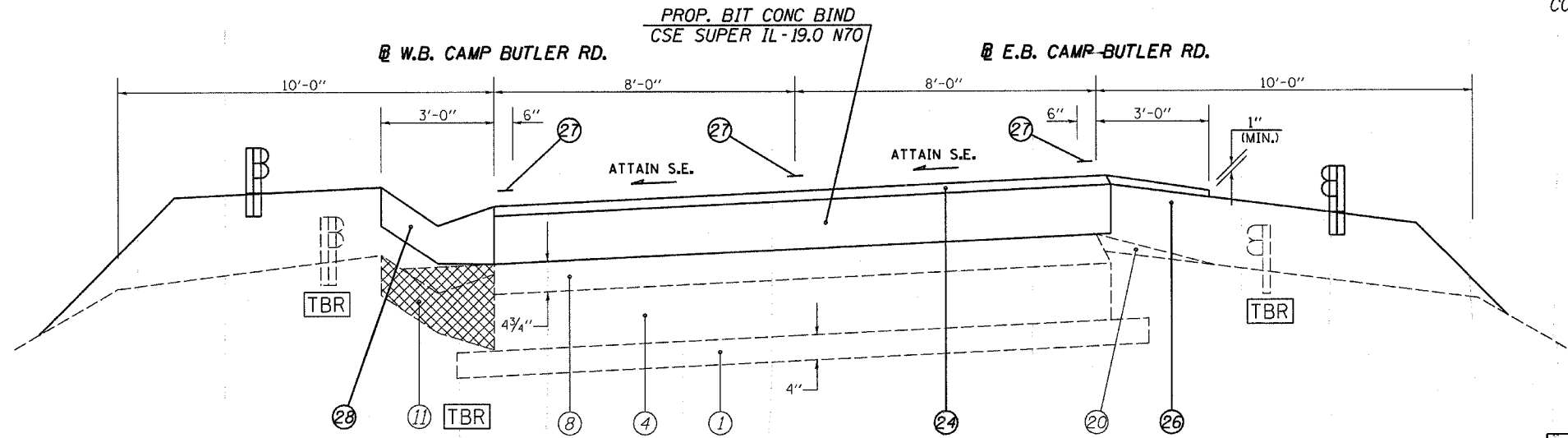

(E.B. CAMP BUTLER RD.)
 (58) STA 15+00.00 TO 16+58.26 [158.26']
 (59) STA 19+60.87 TO 20+60.00 [99.13'] (cont on pg21)

S.N. 084-0086
 STA 16+58.26 TO
 STA 19+60.87

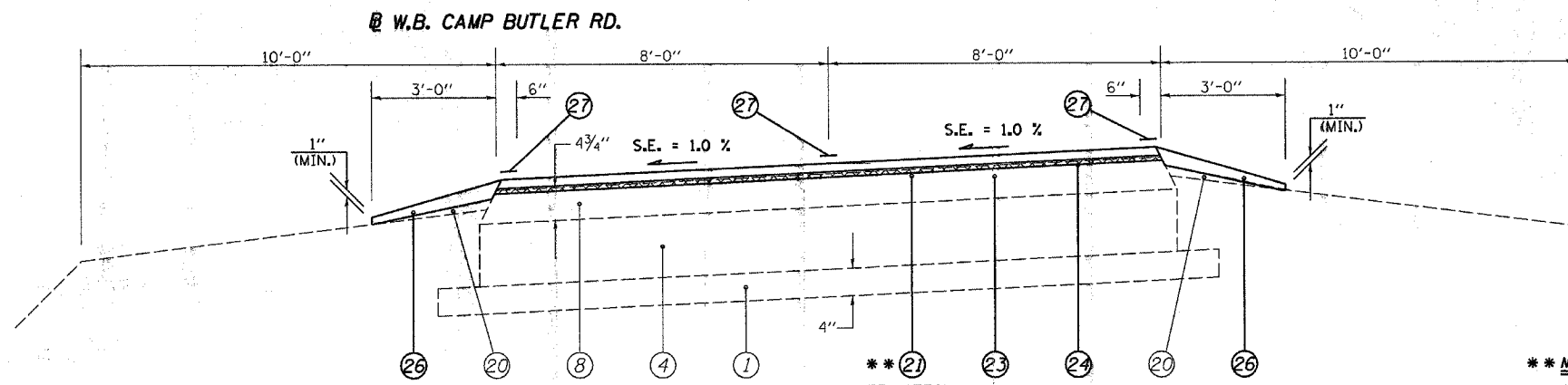

(63) STA 20+50.00 TO 22+42.20 (ENTR.) [192.2'] (fr pg21; cont on pg9)

*** NOTES:
 1/2" MILLING DEPTH ENDS AT STA 22+12.20. MILLING DEPTH TAPERS
 FR 1/2" TO 2" FR STA 22+12.20 TO 22+42.20

LEGEND	
①	EXIST. SUB-BASE GRANULAR MATERIAL
②	EXIST. P.C.C. PAVEMENT 9"
③	EXIST. P.C.C. PAVEMENT 9"-6"-9"
④	EXIST. P.C.C. PAVEMENT 10"
⑤	EXIST. BITUMINOUS BASE COURSE 10"
⑥	EXIST. P.C.C. BASE COURSE WIDENING 9"
⑦	EXIST. STABILIZED BASE COURSE 10"
⑧	EXIST. BITUMINOUS OVERLAY
⑨	EXIST. BITUMINOUS SHOULDERS
⑩	EXIST. PIPE UNDERDRAIN 6"
⑪	EXIST. CONCRETE GUTTER, TYPE A (MODIFIED)
⑫	EXIST. CONCRETE GUTTER, TYPE B
⑬	EXIST. CONCRETE GUTTER, TYPE C (MODIFIED)
⑭	EXIST. P.C.C. CURB & GUTTER, TYPE 10 (MODIFIED)
⑮	EXIST. P.C.C. CURB & GUTTER, TYPE 6
⑯	EXIST. P.C.C. CURB & GUTTER, TYPE 6 (MODIFIED)
⑰	EXIST. P.C.C. CURB & GUTTER, TYPE 7
⑱	EXIST. P.C.C. CURB, TYPE 4
⑲	EXIST. P.C.C. CURB, TYPE 10 (MODIFIED)
⑳	EXIST. AGGREGATE SHOULDERS, TYPE B
㉑	PROP. BITUMINOUS SURFACE REMOVAL (VARIABLE DEPTH) *
㉒	PROP. BITUMINOUS SURFACE REMOVAL 2"
㉓	PROP. LEVELING BINDER (MACHINE METHOD), SUPERPAVE N70 3/4"
㉔	PROP. BITUMINOUS CONCRETE SURFACE COURSE, SUPERPAVE, MIX "D", N70 1 1/2"
㉕	PROP. BITUMINOUS SHOULDERS SUPERPAVE
㉖	PROP. AGGREGATE SHOULDERS, TYPE B
㉗	PROP. PAINT PAVEMENT MARKING - LINE 5"
㉘	PROP. CONCRETE GUTTER, TYPE A (MODIFIED)
㉙	PROP. BITUMINOUS SHOULDER SUPERPAVE 8"
㉚	PROP. GRADING AND SHAPING SHOULDERS

* NOMINAL MILLING DEPTH 1/2"

NOT TO SCALE

REVISIONS		ILLINOIS DEPARTMENT OF TRANSPORTATION
NAME	DATE	
		TYPICAL SECTIONS F.A.U. Route 7978 (OLD US 36) & F.A.U. Route 7968 (CAMP BUTLER RD.) Section 3R(BR, BR-1, BR-2), 19RS-8 SANGAMON COUNTY SCALE: VERT. DRAWN BY: JWC HORIZ. DATE: JULY 20, 2005 CHECKED BY: RSC

(CAMP BUTLER RD.)

• DGN-SPEC
 • DATE-TIME
 • REF ID