

F.A.U. RTE.	SECTION	COUNTY	TOTAL SHEETS	SHEET NO.
*	**	SANGAMON	261	204

STA.	TO STA.
FED. ROAD DIST. NO.	ILLINOIS FED. AID PROJECT

- * 7978 (OLD US 36) & 7968 (CAMP BUTLER RD.)
- ** 3R1BR, BR-1, BR-2, 19RS-8

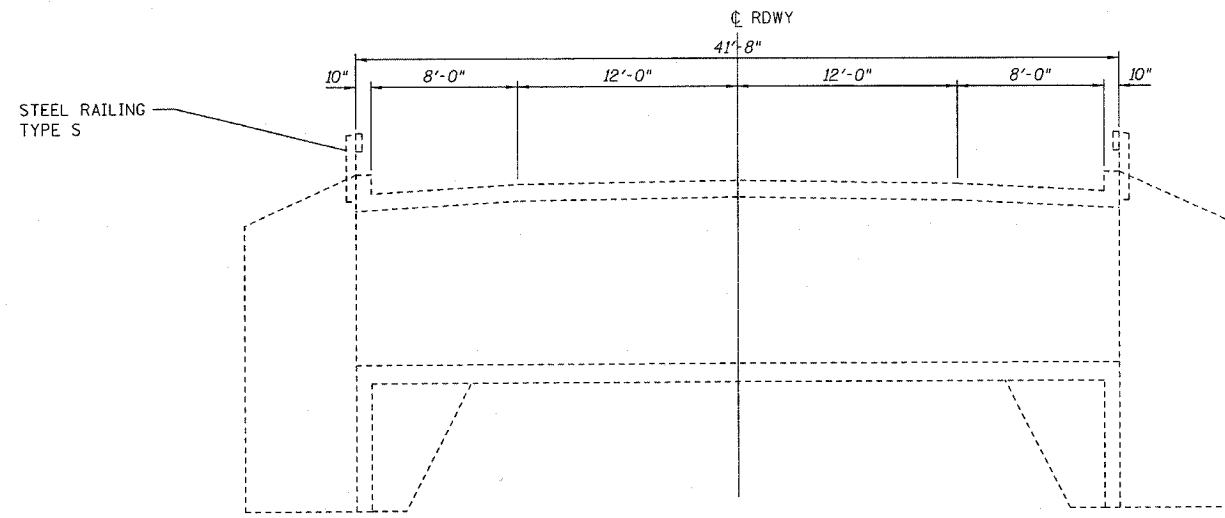

LONGITUDINAL SECTION

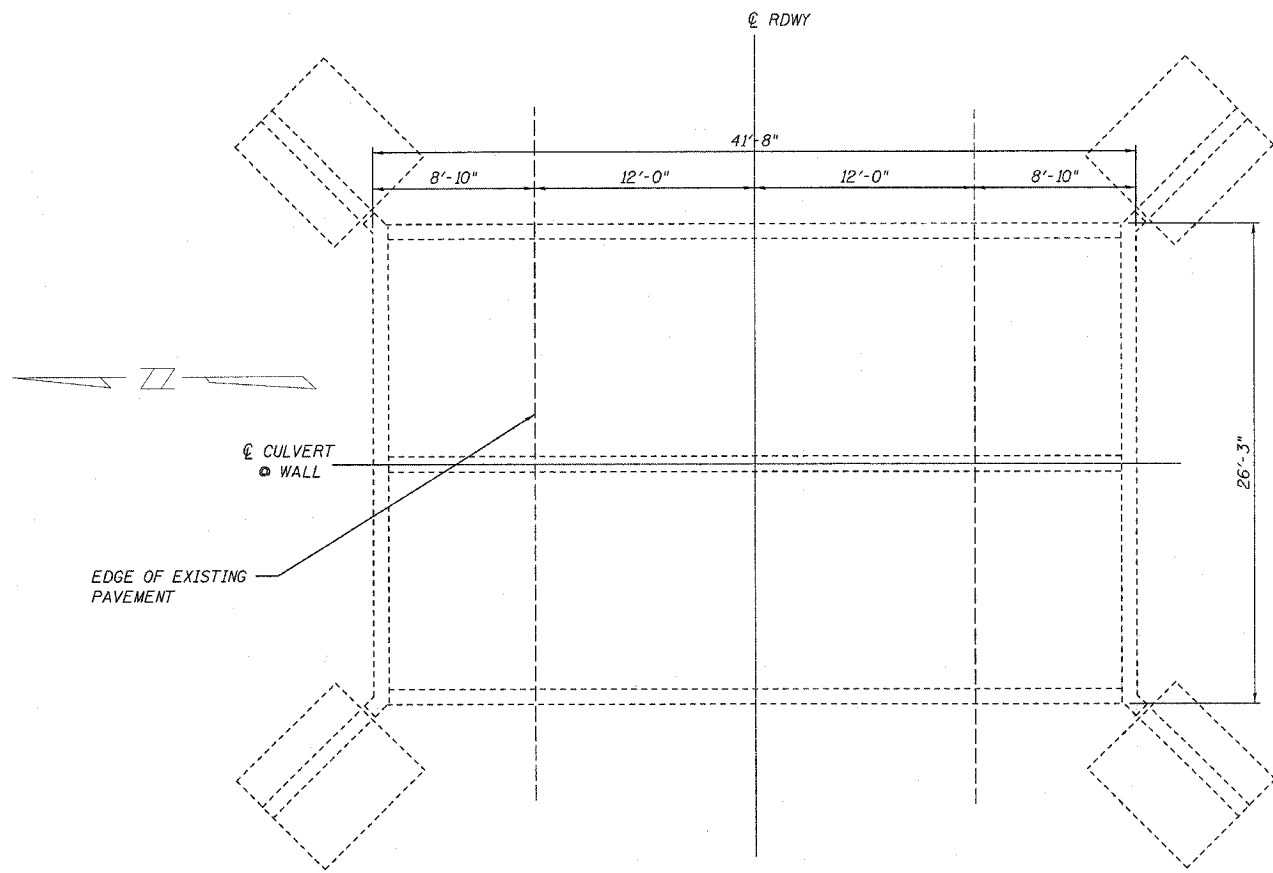

PLAN

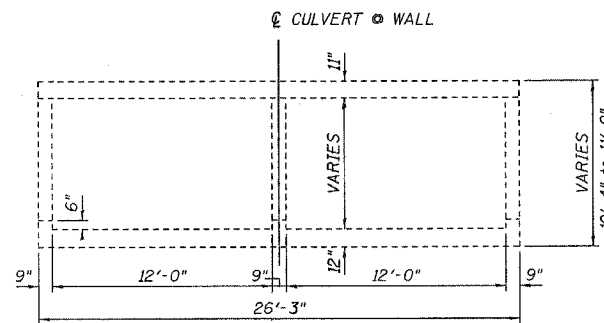

SECTION THRU BARREL

GENERAL NOTES
 PLANS, DIMENSIONS, AND DETAILS OF THE EXISTING STRUCTURE ARE TAKEN FROM EXISTING PLANS AND ARE SUBJECT TO NOMINAL CONSTRUCTION VARIATIONS. IT SHALL BE THE CONTRACTOR'S RESPONSIBILITY TO VERIFY SUCH DIMENSION AND DETAILS IN THE FIELD AND TO MAKE NECESSARY APPROVED ADJUSTMENTS PRIOR TO CONSTRUCTION OR ORDERING MATERIALS. SUCH VARIATIONS SHALL NOT BE CAUSE FOR ADDITIONAL COMPENSATION OR CHANGE IN SCOPE OF WORK; HOWEVER THE CONTRACTOR WILL BE PAID FOR THE QUANTITY ACTUALLY FURNISHED AT THE CONTRACT UNIT PRICE FOR THE WORK.

TOTAL BILL OF MATERIALS		
ITEM	UNIT	TOTAL
BIT. CONC. SURF. CRSE., SUPER, MIX D, N70	TON	10
DECK SLAB REPAIR, (PARTIAL)	SQ YD	53.1
DECK SLAB REPAIR, (FULL)	SQ YD	2.5
WATERPROOF. MEMBRANE SYSTEM	SQ YD	117

REVISIONS	
NAME	DATE

ILLINOIS DEPARTMENT OF TRANSPORTATION
BRIDGE REPAIR DETAILS
 F.A.U. Route 7978 (OLD US 36) &
 F.A.U. Route 7968 (CAMP BUTLER RD.)
 Section 3R1BR, BR-1, BR-2, 19RS-8
 SANGAMON COUNTY

SCALE: VERT. DRAWN BY: TS
 HORIZ. CHECKED BY: RSC
 DATE: OCTOBER 28, 2005