

**CROSS SECTION**  
(40' SPAN)

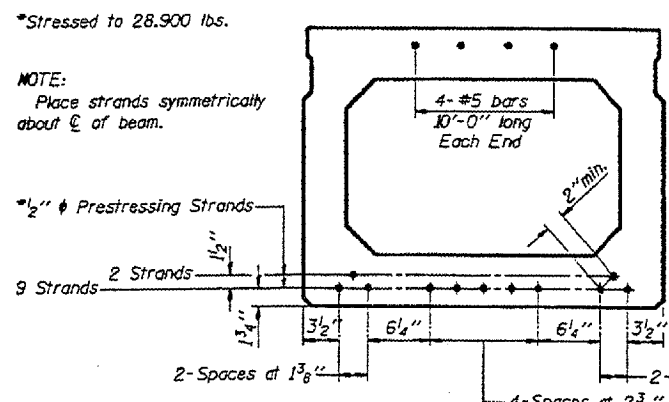

**CROSS SECTION**  
(50' SPAN)

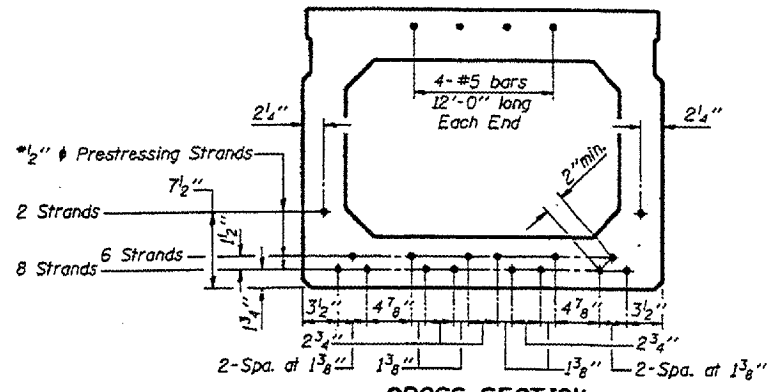

**CROSS SECTION**  
(60' SPAN)

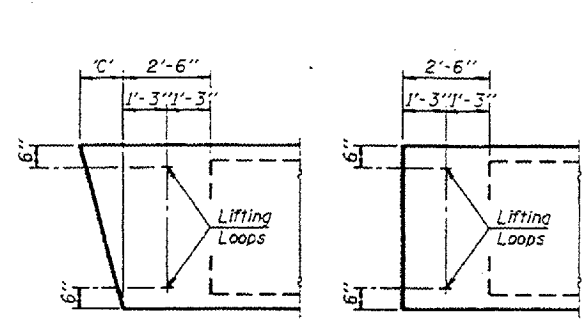

**END BLOCK DETAILS**

Each beam shall have four Lifting Loops, two at each end of beam cast in locations shown above. Loops shall be burned off after beams have been erected.

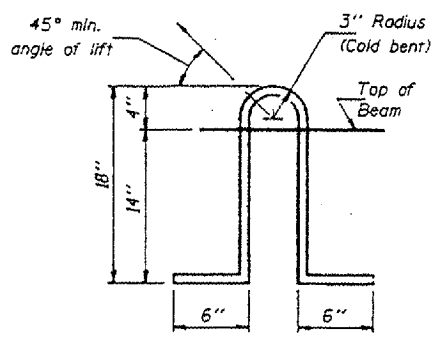

**LIFTING LOOP DETAIL**

Lifting loops shall be 2-1/2" #270 ksi strands, as shown. Alternate approved lifting devices are also acceptable.

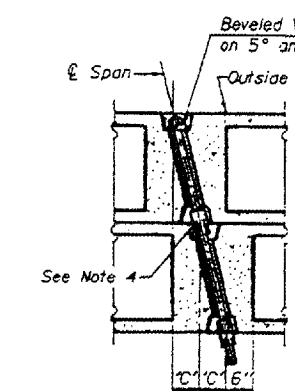

**PARTIAL PLAN TRANSVERSE TIE ASSEMBLY**  
(D=0°, 5° and 10°)

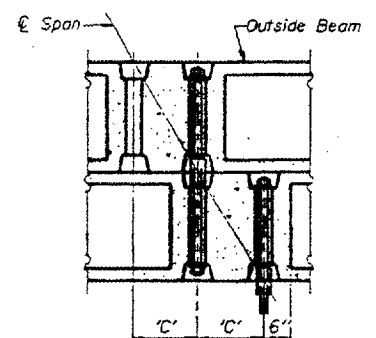

**PARTIAL PLAN TRANSVERSE TIE ASSEMBLY**  
(D=15°, 20°, 25° and 30°)

**DIMENSION 'C'**

Skew Angle 'D'	0°	5°	10°	15°	20°	25°	30°
Dimension 'C' (Inches)	0	3 3/8	6 3/8	9 3/8	13 3/8	16 3/4	20 3/4

\*Stressed to 28,900 lbs.  
NOTE:  
Place strands symmetrically about centerline of beam.

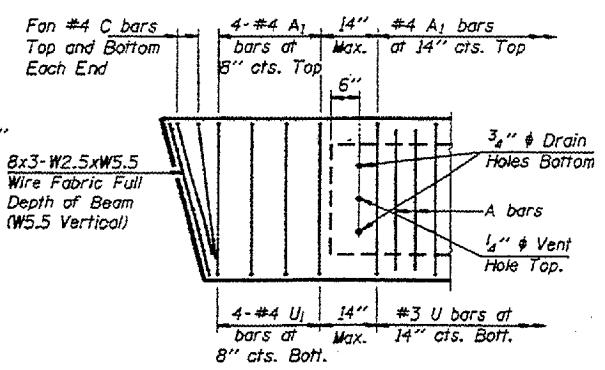

**END REINFORCEMENT**  
(SKEWED)

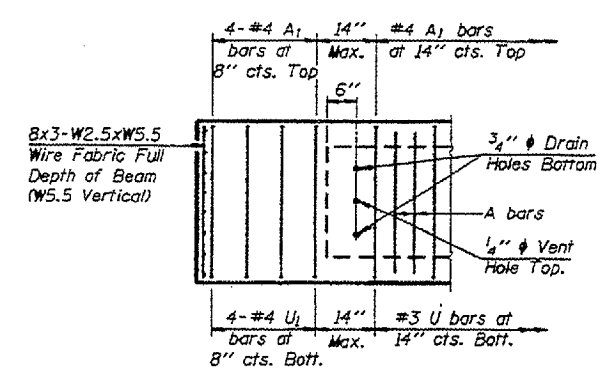

**END REINFORCEMENT**  
(RIGHT ANGLE)

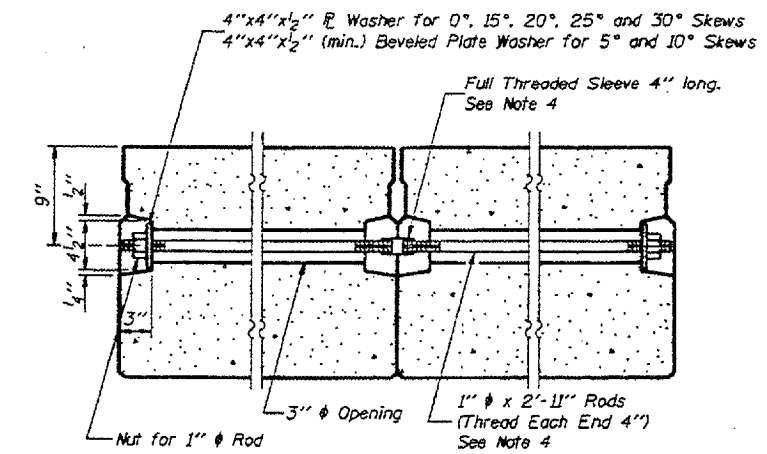

**SECTION ALONG TRANSVERSE TIE ASSEMBLY**  
(REQUIRED FOR 50' & 60' SPANS ONLY)

**NOTES**

1. Prestressing steel shall be uncoated high strength, stress relieved 7-wire strand, Grade 270.
2. The nominal diameter shall be 1/2" and the nominal cross-sectional area shall be 0.153 square inches.
3. Reinforcement bars shall conform to AASHTO M-31 M-42 or M-53, Grade 60.
4. On 0°, 5° and 10° skew angles, alternate approved transverse tie rods of increased segmental length are acceptable.
5. Rail Post anchor devices shall be cast into outside beam as elsewhere specified.
6. When Waterproofing Membrane System is specified, the top surface of the beams shall be finished in accordance with Article 504.05 of the Standard Specifications except that the surface shall not be roughened by brooming. The finished surface shall be free of depressions or high spots with sharp corners, and the top edge of keys shall be rounded or chamfered a minimum of 1/4".
7. Low relaxation strands may be substituted for the stress relieved strands. The initial prestressing force applied to each strand shall be the same as for the stress relieved strands (28,900 lbs.).
8. Keyway surfaces shall be cleaned to remove form oil or other bond breaking material prior to shipment of the beams. Cleaning shall be done by sandblasting the keyway areas between the top of the beam and the bottom edge of the key.

Illinois Department of Transportation  
PASSED NOVEMBER 1, 1995  
Engineer of Bridge Design  
APPROVED NOVEMBER 1, 1995  
Engineer of Bridges and Structures

NOTE:  
The std. reinf. shown on the 40' span cross section is typical for all spans, except as shown.

\*\*NOTE:  
The following number of C bars shall be used:  
Skew No.  
5° and 10° — 1  
15° and 20° — 2  
25° and 30° — 3

**DESIGN STRESSES**

$f'_c = 5,000$  p.s.i.  
 $f'_a =$  (See Required Release Strength Table)  
 $f'_s = 270,000$  p.s.i. (1/2" # Strand)  
 $f_{sl} = 189,000$  p.s.i. (1/2" # Strand)  
 $f_y = 60,000$  p.s.i.

**REQUIRED RELEASE STRENGTH**

Span	$f'_a$ (psi)
40'	4,000
50'	4,000
60'	4,000

**P.P.C. DECK BEAM DETAILS**

24' ROADWAY | 27" x 36" BEAMS  
STANDARD CB-2427-36