

FOR INDEX OF SHEETS, SEE SHEET NO. 2

DESIGN DESIGNATION:

SPEED LIMIT: 40 TO 45 M.P.H.

2009 ADT = 27,300 (WARRENVILLE RD. TO PARK BLVD.)

15,700-16,500 (PARK BLVD. TO IL RTE. 38)

PROJECT LOCATED IN THE VILLAGES OF LISLE, GLEN ELLYN, AND DOWNERS GROVE

**STATE OF ILLINOIS
DEPARTMENT OF TRANSPORTATION**

DIVISION OF HIGHWAYS

**PROPOSED
HIGHWAY PLANS**

FAP 870 (IL RTE. 53)

SECTION 534X-RS-5

FAU 1479 (WARRENVILLE RD.) TO FAP 347 (IL RTE. 38)

RESURFACING (3P)

DUPAGE COUNTY

C-91-313-11

F.A. RTE.	SECTION	COUNTY	TOTAL SHEETS	SHEET NO.
870	534X-RS-5	DUPAGE	35	1
FED. ROAD DIST. NO.	ILLINOIS	CONTRACT NO. 60N43		

D-91-313-11



**PROJECT ENDS
STA. 205 + 72**

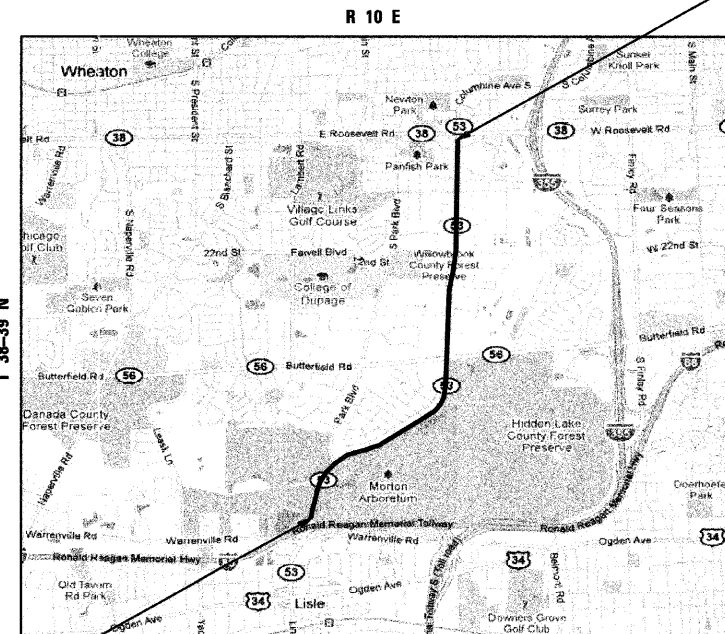

OMISSIONS:
STA. 13 + 61 TO STA. 15 + 15 (SB)
STA. 27 + 24 TO STA. 27 + 58 (SB)
STA. 27 + 32 TO STA. 27 + 66 (NB)
STA. 34 + 54 TO STA. 36 + 49 (SB)
STA. 34 + 83 TO STA. 36 + 83 (NB)

**PROJECT BEGINS
STA. 13 + 61**

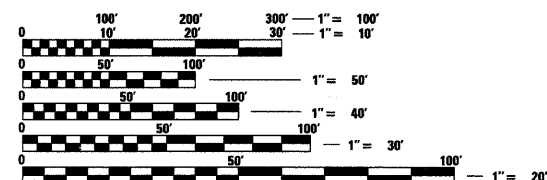

FULL SIZE PLANS HAVE BEEN PREPARED USING STANDARD ENGINEERING SCALES. REDUCED SIZED PLANS WILL NOT CONFORM TO STANDARD SCALES. IN MAKING MEASUREMENTS ON REDUCED PLANS, THE ABOVE SCALES MAY BE USED.

J.U.L.I.E.
 JOINT UTILITY LOCATION INFORMATION FOR EXCAVATION
 1-800-892-0123
 OR 811

GROSS LENGTH OF PROJECT = 19,211 FT. = 3.64 MILE
NET LENGTH OF PROJECT = 18,594 FT. = 3.52 MILE

DISTRICT ONE - PLAN PREPARATION ENGINEER: KEN ENG: (847) 705-4247

CONTRACT NO. 60N43

STATE OF ILLINOIS
 DEPARTMENT OF TRANSPORTATION
 DIVISION OF HIGHWAYS

SUBMITTED OCTOBER 20, 2011

Diana M. O'Keefe, PE
 DEPUTY DIRECTOR OF HIGHWAYS, REGION ENGINEER

December 9, 2011
Scott E. Stett, P.E./a
 acting ENGINEER OF DESIGN AND ENVIRONMENT

December 9, 2011
William R. Frenkel
 INTERIM DIRECTOR OF HIGHWAYS, CHIEF ENGINEER

PROFESSIONAL ENGINEER'S SIGN & SEAL

Christopher M. Heather

EXPIRES: 11/30/2011

**PRINTED BY THE AUTHORITY
OF THE STATE OF ILLINOIS**

INDEX OF SHEETS

1	COVER SHEET
2	INDEX OF SHEETS, LIST OF STATE STANDARDS, AND GENERAL NOTES
3	SUMMARY OF QUANTITIES
4-5	TYPICAL SECTIONS
6-12	ROADWAY PLAN
13-19	PAVEMENT MARKING PLAN
20-23	DETECTOR LOOP PLAN
24	DRIVEWAY DETAILS - DISTANCE BETWEEN R.O.W. AND FACE OF CURB & EDGE OF SHOULDER >= 15' (4.5 m) (BD-01)
25	DETAILS FOR FRAMES AND LIDS ADJUSTMENT WITH MILLING (BD-08)
26	PAVEMENT PATCHING FOR HMA SURFACED PAVEMENT (BD-22)
27	CURB OR CURB AND GUTTER REMOVAL AND REPLACEMENT (BD-24)
28	BUTT JOINT AND HMA TAPER DETAILS (BD-32)
29	TRAFFIC CONTROL AND PROTECTION FOR SIDE ROADS, INTERSECTIONS, AND DRIVEWAYS (TC-10)
30	TYPICAL APPLICATIONS RAISED REFLECTIVE PAVEMENT MARKERS (SNOW-PLOW RESISTANT) (TC-11)
31	DISTRICT ONE TYPICAL PAVEMENT MARKINGS (TC-13)
32	PAVEMENT MARKING LETTERS AND SYMBOLS FOR TRAFFIC STAGING (TC-16)
33	ARTERIAL ROAD INFORMATION SIGN (TC-22)
34	DISTRICT 1 STANDARD TRAFFIC SIGNAL DETAILS (TS-05)
35	DISTRICT 1 - DETECTOR LOOP INSTALLATION DETAILS FOR ROADWAY RESURFACING (TS-07)

LIST OF STATE STANDARDS

STANDARD NO.	DESCRIPTION
000001-00	STANDARD SYMBOLS, ABBREVIATIONS AND PATTERNS
442201-03	CLASS C AND D PATCHES
482011-03	HMA SHOULDER STRIPS/SHOULDERS WITH RESURFACING OR WIDENING AND RESURFACING PROJECTS
606001-04	CONCRETE CURB TYPE B AND COMBINATION CONCRETE CURB AND GUTTER
606301-04	PC CONCRETE ISLANDS AND MEDIANS
701421-04	LANE CLOSURE, MULTILANE, DAY OPERATIONS ONLY, FOR SPEEDS >= 45 MPH TO 55 MPH
701422-02	LANE CLOSURE, MULTILANE, FOR SPEEDS >= 45 MPH TO 55 MPH
701426-04	LANE CLOSURE, MULTILANE, INTERMITTENT OR MOVING OPER., FOR SPEEDS >= 45 MPH
701427	LANE CLOSURE, MULTILANE, INTERMITTENT OR MOVING OPER., FOR SPEEDS <= 40 MPH
701501-00	URBAN LANE CLOSURE, 2L, 2W, UNDIVIDED
701601-07	URBAN LANE CLOSURE, MULTILANE, 1W OR 2W WITH NONTRAVERSABLE MEDIAN
701701-08	URBAN LANE CLOSURE, MULTILANE INTERSECTION
701901-02	TRAFFIC CONTROL DEVICES

GENERAL NOTES

1. BEFORE STARTING ANY EXCAVATION, THE CONTRACTOR SHALL CALL "JULIE" (JOINT UTILITY LOCATION INFORMATION FOR EXCAVATION) AT 8-1-1 OR (800) 892-0123 FOR FIELD LOCATIONS OF BURIED ELECTRIC, TELEPHONE, AND GAS FACILITIES (48 HOUR NOTIFICATION IS REQUIRED).
2. 10 FOOT TRANSITIONS SHALL BE USED TO MATCH PROPOSED CURB AND GUTTER ITEMS OF WORK TO EXISTING CURBS AND GUTTERS AND CONDITIONS IN THE FIELD UNLESS OTHERWISE SHOWN. THE TRANSITIONS SHALL BE PAID FOR AT THE CONTRACT UNIT PRICE FOR THE PROPOSED ITEMS OF WORK SPECIFIED.
3. THE CONTRACTOR SHALL COORDINATE CONSTRUCTION ACTIVITIES WITH UTILITY COMPANIES AND THE VILLAGES OF LISLE, GLEN ELLYN, AND DOWNERS GROVE.
4. WHEN ARTIFICIAL LIGHTING IS USED IN NIGHT OPERATIONS, THE CONTRACTOR SHALL EXERCISE THE UTMOST PRECAUTIONS IN PREVENTING ADVERSE VISIBILITY TO THE MOTORING PUBLIC AND ADJOINING RESIDENTIAL AREAS.
5. THE CONTRACTOR WILL NOT BE ALLOWED TO SET UP A YARD OR FIELD OFFICE ON STATE PROPERTY WITHOUT WRITTEN PERMISSION FROM THE DEPARTMENT.
6. SAW CUTTING OF PAVEMENTS, SIDEWALK, CURB & GUTTER, ETC. SHALL BE TO FULL DEPTH AND SHALL RESULT IN A CLEAN STRAIGHT EDGE ON THE PORTION REMAINING. ALL SAW CUTTING SHALL BE CONSIDERED INCLUDED IN THE COST OF THE ITEM REMOVED.
7. DO NOT SCALE PLANS FOR CONSTRUCTION DIMENSIONS.
8. THE CONTRACTOR SHALL USE CARE IN REMOVING OR EXCAVATING NEAR ALL EXISTING ITEMS WHICH WILL REMAIN. ANY DAMAGE DONE TO EXISTING ITEMS BY THE CONTRACTOR SHALL BE REPAIRED AT THE CONTRACTOR'S EXPENSE.
9. WHEN MILLED PAVEMENT IS OPEN TO TRAFFIC, THE MAXIMUM GRADE DIFFERENTIAL BETWEEN PASSES OF THE MILLING MACHINE SHALL NOT EXCEED 1.5 INCHES (40mm) WHERE THE SPEED LIMIT IS 40 MPH OR LESS AND 1 INCH WHERE THE SPEED LIMIT IS GREATER THAN 45 MPH. WITH WRITTEN APPROVAL FROM THE ENGINEER, A MAXIMUM GRADE DIFFERENTIAL OF 3 INCHES MAY BE ALLOWED IF THE EDGE OF MILLING IS SLOPED A MINIMUM OF 1:3 (V:H).
10. UNLESS OTHER CONDITIONS WARRANT EXTENDED LANE CLOSURE AS DETERMINED AND APPROVED IN WRITING BY THE ENGINEER OR AS PROVIDED FOR IN THE CONTRACT SPECIFICATIONS, OVERNIGHT CLOSURES SHALL NOT BE ALLOWED FOR REHABILITATION PROJECTS INVOLVING DAYTIME MILLING AND RESURFACING OPERATIONS AND CLASS D PATCHING.
11. BEFORE BEGINNING ANY WORK, THE CONTRACTOR SHALL RETAIN AND RECORD FOR FUTURE REFERENCE ALL EXISTING PAVEMENT MARKING LINES AND RAISED REFLECTIVE PAVEMENT MARKERS IN ORDER THAT THESE LOCATIONS CAN BE RE-ESTABLISHED FOR STRIPING. EXACT LOCATIONS OF ALL PAVEMENT MARKING SHALL BE AS DIRECTED BY THE ENGINEER.
12. PAVEMENT MARKING TAPE, TYPE III SHALL BE USED FOR SHORT TERM PAVEMENT MARKINGS AND TEMPORARY PAVEMENT MARKING ON ALL FINAL SURFACES. THE COST OF THE PAVEMENT MARKING TAPE TYPE III SHALL BE INCLUDED IN THE COST OF SHORT TERM PAVEMENT MARKINGS AND TEMPORARY PAVEMENT MARKINGS.
13. THE RESIDENT ENGINEER SHALL CONTACT THE TRAFFIC CONTROL SUPERVISOR AT (847) 705-4470 A MINIMUM OF 72 HOURS PRIOR TO THE PLACEMENT OF ANY TEMPORARY TRAFFIC CONTROL DEVICES.
14. THE RESIDENT ENGINEER SHALL CONTACT MR. DON CHIARUGI, THE AREA TRAFFIC FIELD ENGINEER, AT (847) 741-9857 AT LEAST TWO (2) WEEKS PRIOR TO THE PLACEMENT OF PERMANENT PAVEMENT MARKINGS.
15. LOCATIONS OF PAVEMENT PATCHING AND CURB & GUTTER REMOVAL & REPLACEMENT WILL BE DETERMINED IN THE FIELD BY THE ENGINEER.
16. BUTT JOINTS WILL BE INSTALLED AT THE ENDS OF ALL RESURFACING (WHERE RESURFACING MEETS EXISTING PAVEMENT), IN ACCORDANCE THE "BUTT JOINT AND HMA TAPER DETAILS" INCLUDED IN THE PLANS, UNLESS OTHERWISE SPECIFIED.
17. MATCH EXISTING PAVEMENT MARKINGS AT THE PROJECT LIMITS.
18. ALL DAMAGE TO EXISTING PAVEMENT MARKINGS OUTSIDE THE REMOVAL LINE SHOWN ON THE PLANS SHALL BE REPLACED AT THE CONTRACTORS EXPENSE.
19. THE CONTRACTOR SHALL BE RESPONSIBLE FOR CONTACTING OWNERS OF ALL UTILITIES PRIOR TO CONSTRUCTION TO DETERMINE THE LOCATION OF ALL UTILITY EQUIPMENT. THE CONTRACTOR SHALL COOPERATE WITH ALL UTILITY OWNERS IN ACCORDANCE WITH THE STANDARD SPECIFICATIONS IF UTILITY RELOCATION, ADJUSTMENT, OR PROTECTION IS NECESSARY.
20. THE LOCATION OF EXISTING DRAINAGE STRUCTURES, STORM SEWERS, WATER MAINS, SANITARY SEWERS, AND ANY OTHER PUBLIC OR PRIVATE UTILITIES AS SHOWN ON THE PLANS IS APPROXIMATE AND THEIR EXACT LOCATION IS TO BE DETERMINED IN THE FIELD BY THE CONTRACTOR
21. THE CONTRACTOR SHALL BE RESPONSIBLE FOR THE PROTECTION OF ALL UNDERGROUND AND SURFACE UTILITIES EVEN THOUGH THEY MIGHT NOT BE SHOWN ON THE PLANS. ANY UTILITY PROPERTY DAMAGED DURING CONSTRUCTION SHALL BE REPAIRED OR REPLACED TO THE SATISFACTION OF THE ENGINEER.
22. ANY LOOSE MATERIAL DEPOSITED IN THE FLOW LINE OF DRAINAGE STRUCTURES, WHICH OBSTRUCTS THE NATURAL FLOW OF WATER SHALL BE REMOVED AT THE CLOSE OF EACH WORKING DAY. PRIOR TO ACCEPTANCE OF THE IMPROVEMENT, ALL DRAINAGE STRUCTURES SHALL BE FREE OF DIRT AND DEBRIS. THIS WORK WILL NOT BE PAID FOR SEPARATELY, BUT SHALL BE CONSIDERED AS INCLUDED IN THE UNIT BID PRICES OF THE CONTRACT.
23. EXISTING BROKEN FRAMES AND LIDS SHALL BE REMOVED AND DISPOSED OF BY THE CONTRACTOR AND SHALL BE REPLACED AS DIRECTED BY THE ENGINEER. REPLACEMENT FRAMES AND LIDS WILL BE PAID FOR ACCORDING TO ARTICLE 109.04 OF THE STANDARD SPECIFICATIONS UNLESS A SEPARATE PAY ITEM HAS BEEN PROVIDED.

COMPANY NAME: HRGreen.com
 PROJECT CONTACT: J. ROITBURD
 CLIENT CONTACTED: J. ROITBURD
 FILE NAME: 8610098608-08-01.dgn
 PLOT DRIVER: pdf.plt
 PEN TABLE: standard-trans.tbl



USER NAME = SPernell	DESIGNED - J. ROITBURD	REVISED -
PLOT SCALE = N.T.S.	DRAWN - R. BEST	REVISED -
PLOT DATE = 10/24/2011	CHECKED - T. HAMILTON	REVISED -
	DATE - 10/24/11	REVISED -

**STATE OF ILLINOIS
DEPARTMENT OF TRANSPORTATION**

INDEX OF SHEETS, LIST OF STATE STANDARDS AND GENERAL NOTES

SCALE: N.T.S. SHEET NO. 1 OF 1 SHEETS STA. TO STA.

F.A.P. RTE.	SECTION	COUNTY	TOTAL SHEETS	SHEET NO.
870	534X-RS-5	DUPAGE	35	2
CONTRACT NO. 60N43				
FED. ROAD DIST. NO. ILLINOIS FED. AID PROJECT				

SUMMARY OF QUANTITIES

CODE NO.	ITEM	UNIT	URBAN 100% STATE	
			TOTAL QUANTITY	ROADWAY 0005
21101615	TOPSOIL FURNISH AND PLACE, 4"	SO YD	70	70
25200110	SODDING, SALT TOLERANT	SO YD	70	70
35501316	HOT-MIX ASPHALT BASE COURSE, 8"	SO YD	9	9
40600200	BITUMINOUS MATERIALS (PRIME COAT)	TON	87	87
40600300	AGGREGATE (PRIME COAT)	TON	434	434
40600400	MIXTURE FOR CRACKS, JOINTS, AND FLANGEWAYS	TON	45	45
40600827	POLYMERIZED LEVELING BINDER (MACHINE METHOD), IL-4.75, N50	TON	4,555	4,555
40600895	CONSTRUCTING TEST STRIP	EACH	2	2
40600982	HOT-MIX ASPHALT SURFACE REMOVAL - BUTT JOINT	SO YD	855	855
40601005	HOT-MIX ASPHALT REPLACEMENT OVER PATCHES	TON	130	130
40603335	HOT-MIX ASPHALT SURFACE COURSE, MIX "D", N50	TON	1	1
40603595	POLYMERIZED HOT-MIX ASPHALT SURFACE COURSE, MIX "F", N90	TON	10,627	10,627
42001300	PROTECTIVE COAT	SO YD	247	247
44000159	HOT-MIX ASPHALT SURFACE REMOVAL, 2 1/2"	SO YD	108,441	108,441
44000200	DRIVEWAY PAVEMENT REMOVAL	SO YD	9	9
44002209	HOT-MIX ASPHALT REMOVAL OVER PATCHES, 2 1/4"	SO YD	1,030	1,030
44003100	MEDIAN REMOVAL	SO FT	1,185	1,185
44201765	CLASS D PATCHES, TYPE II, 10 INCH	SO YD	292	292
44201769	CLASS D PATCHES, TYPE III, 10 INCH	SO YD	237	237
44201771	CLASS D PATCHES, TYPE IV, 10 INCH	SO YD	261	261
44201815	CLASS D PATCHES, TYPE II, 14 INCH	SO YD	876	876
44201819	CLASS D PATCHES, TYPE III, 14 INCH	SO YD	711	711
44201821	CLASS D PATCHES, TYPE IV, 14 INCH	SO YD	782	782
48102100	AGGREGATE WEDGE SHOULDER, TYPE B	TON	2,415	2,415
60618208	HOT-MIX ASPHALT MEDIAN	SO FT	1,185	1,185
67000400	ENGINEER'S FIELD OFFICE, TYPE A	CAL MO	6	6
67100100	MOBILIZATION	L SUM	1	1
70100310	TRAFFIC CONTROL AND PROTECTION, STANDARD 701421	L SUM	1	1
70100320	TRAFFIC CONTROL AND PROTECTION, STANDARD 701422	L SUM	1	1
70102620	TRAFFIC CONTROL AND PROTECTION, STANDARD 701501	L SUM	1	1
70102630	TRAFFIC CONTROL AND PROTECTION, STANDARD 701601	L SUM	1	1
70102635	TRAFFIC CONTROL AND PROTECTION, STANDARD 701701	L SUM	1	1
70300100	SHORT-TERM PAVEMENT MARKING	FOOT	25,705	25,705
70300210	TEMPORARY PAVEMENT MARKING LETTERS AND SYMBOLS	SO FT	965	965
70300220	TEMPORARY PAVEMENT MARKING - LINE 4"	FOOT	66,030	66,030
70300240	TEMPORARY PAVEMENT MARKING - LINE 6"	FOOT	4,380	4,380
70300250	TEMPORARY PAVEMENT MARKING - LINE 8"	FOOT	20	20

CODE NO.	ITEM	UNIT	URBAN 100% STATE	
			TOTAL QUANTITY	ROADWAY 0005
70300260	TEMPORARY PAVEMENT MARKING - LINE 12"	FOOT	2,880	2,880
70300280	TEMPORARY PAVEMENT MARKING - LINE 24"	FOOT	895	895
70301000	WORK ZONE PAVEMENT MARKING REMOVAL	SO FT	8,570	8,570
78000100	THERMOPLASTIC PAVEMENT MARKING - LETTERS AND SYMBOLS	SO FT	965	965
78000200	THERMOPLASTIC PAVEMENT MARKING - LINE 4"	FOOT	66,030	66,030
78000400	THERMOPLASTIC PAVEMENT MARKING - LINE 6"	FOOT	4,380	4,380
78000500	THERMOPLASTIC PAVEMENT MARKING - LINE 8"	FOOT	20	20
78000600	THERMOPLASTIC PAVEMENT MARKING - LINE 12"	FOOT	2,880	2,880
78000650	THERMOPLASTIC PAVEMENT MARKING - LINE 24"	FOOT	895	895
78100100	RAISED REFLECTIVE PAVEMENT MARKER	EACH	840	840
78300200	RAISED REFLECTIVE PAVEMENT MARKER REMOVAL	EACH	840	840
88600600	DETECTOR LOOP REPLACEMENT	FOOT	3,580	3,580
X2020110	GRADING AND SHAPING SHOULDERS	UNIT	220	220
X5537800	STORM SEWERS TO BE CLEANED 12"	FOOT	100	100
X6030310	FRAMES AND LIDS TO BE ADJUSTED (SPECIAL)	EACH	15	15
Z0004562	COMBINATION CONCRETE CURB & GUTTER REMOVAL AND REPLACEMENT	FOOT	740	740
Z0017800	DRAINAGE & UTILITY STRUCTURES TO BE RECONSTRUCTED (SPECIAL)	EACH	5	5
Z0018500	DRAINAGE STRUCTURES TO BE CLEANED	EACH	15	15
Z0030850	TEMPORARY INFORMATION SIGNING	SO FT	129	129

- SPECIALTY ITEMS
- △ NON-PARTICIPATING

COMPANY NAME: HRGreen
 PROJECT CONTACT: J. ROITBURD
 CLIENT: HRGreen
 DATE PLOTTED: 10/25/2011 11:30:37 PM
 FILE NAME: 66100096.06-sum.dgn
 PLOT DRIVER: pdfplot
 PLOT TABLE: stransbrdr-trans.tbl



USER NAME = SPermal	DESIGNED - J. ROITBURD	REVISED -
	DRAWN - R. BEST	REVISED -
PLOT SCALE = N.T.S.	CHECKED - T. HAMILTON	REVISED -
PLOT DATE = 10/25/2011	DATE - 10/25/11	REVISED -

STATE OF ILLINOIS
DEPARTMENT OF TRANSPORTATION

SUMMARY OF QUANTITIES	
SCALE: N.T.S.	SHEET NO. 1 OF 1 SHEETS STA. TO STA.

F.A.P. RTE.	SECTION	COUNTY	TOTAL SHEETS	SHEET NO.
870	534X-RS-5	DUPAGE	35	3
FED. ROAD DIST. NO. ILLINOIS FED. AID PROJECT			CONTRACT NO. 60N43	

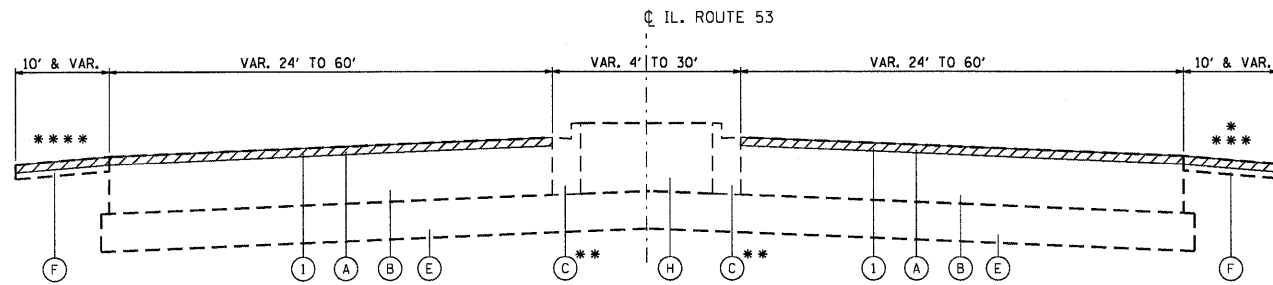

EXISTING TYPICAL SECTION

STA. 13+61 TO STA. 56+40
 OMISSIONS AT STA. 13+61 TO STA. 15+55 (SB)
 STA. 27+24 TO STA. 27+58 (SB)
 STA. 27+32 TO STA. 27+66 (NB)
 STA. 34+54 TO STA. 36+49 (SB)
 STA. 34+83 TO STA. 36+83 (NB)
 * AGGREGATE SHOULDER STA. 46+61 TO STA. 56+40
 ** CURB & GUTTER ENDS AT STA. 44+50 RT.
 AND STA. 46+50 LT.
 *** CURB & GUTTER: STA. 38+20 TO STA. 41+80
 **** CURB & GUTTER: STA. 39+57 TO STA. 43+26

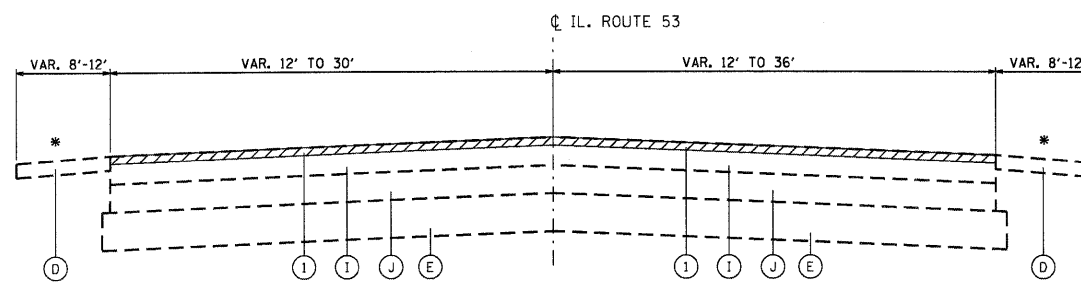

EXISTING TYPICAL SECTION

STA. 58+42 TO STA. 131+21
 STA. 136+20 TO STA. 158+21
 STA. 168+69 TO STA. 205+72
 * HMA SHOULDER STA. 58+42 TO STA. 63+52 LT.
 HMA SHOULDER STA. 92+61 TO STA. 98+75 RT.
 HMA SHOULDER STA. 147+69 TO STA. 149+23 LT.
 HMA SHOULDER STA. 149+15 TO STA. 149+80 RT.
 HMA SHOULDER STA. 173+25 TO STA. 178+53 RT.
 HMA SHOULDER STA. 183+00 TO STA. 183+91 RT.
 HMA SHOULDER STA. 190+74 TO STA. 191+35 RT.
 HMA SHOULDER STA. 192+89 TO STA. 194+54 RT.
 HMA SHOULDER STA. 195+59 TO STA. 196+43 LT.
 HMA SHOULDER STA. 195+96 TO STA. 199+63 RT.
 HMA SHOULDER STA. 201+44 TO STA. 202+59 LT.
 GRASS MEDIAN STA. 56+40 TO STA. 59+42
 GRASS MEDIAN STA. 98+75 TO STA. 122+00
 HMA MEDIAN STA. 202+59 TO STA. 205+72

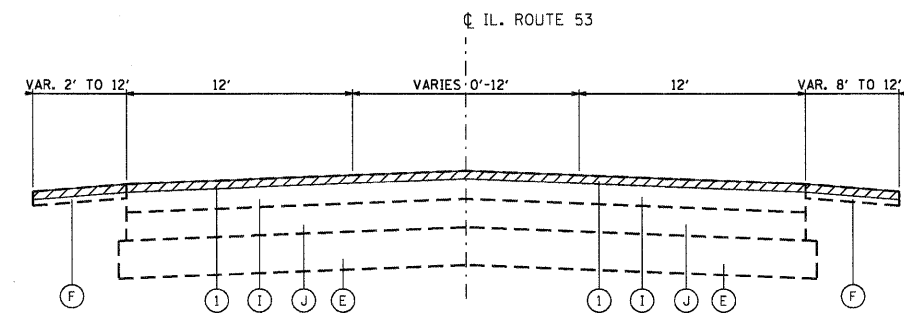

EXISTING TYPICAL SECTION

STA. 131+21 TO STA. 136+20
 STA. 158+21 TO STA. 168+69

EXISTING CONDITIONS

- (A) HMA RESURFACING, ±2 1/4"
- (B) PCC PAVEMENT, ±10"
- (C) COMBINATION CONCRETE CURB AND GUTTER
- (D) AGGREGATE SHOULDERS
- (E) AGGREGATE BASE COURSE
- (F) HMA SHOULDERS
- (H) CONCRETE MEDIAN / GRASS MEDIAN
- (I) HMA RESURFACING, ±8"
- (J) PCC PAVEMENT, ±8"

PROPOSED IMPROVEMENTS

- (1) HOT-MIX ASPHALT SURFACE REMOVAL, 2 1/2"
- (2) POLYMERIZED HOT-MIX ASPHALT SURFACE COURSE, MIX "F", N90, 1 3/4"
- (3) POLYMERIZED LEVELING BINDER (MACHINE METHOD), IL-4.75, N50, 3/4"
- (4) COMBINATION CONCRETE CURB & GUTTER REMOVAL AND REPLACEMENT (AT LOCATIONS AS DETERMINED BY THE ENGINEER)
- (5) AGGREGATE WEDGE SHOULDER, TYPE B (TAPER 3" TO 1" THICKNESS)

NOTES:

REMOVAL OF THE EXISTING HMA SURFACE COURSE 2 1/4" FROM STA. 13+61 TO STA. 56+40 SHALL BE PAID FOR AS "HMA SURFACE REMOVAL, 2 1/2"."

COMPANY NAME: HRGreen.com
 PROJECT CONTACT: #PROJECT_CONTACT1
 CLIENT: #CLIENT1
 DATE PLOTTED: 10/24/2011 2:12:18 PM
 FILE NAME: 86100196.06-1typ-01.dgn
 PLOT DRIVER: pdf.plt
 PEN TABLE: standard-trans.tbl



USER NAME = SPernol	DESIGNED - J. ROITBURD	REVISED -
PLOT SCALE = N.T.S.	DRAWN - R. BEST	REVISED -
PLOT DATE = 10/24/2011	CHECKED - T. HAMILTON	REVISED -
	DATE - 10/24/11	REVISED -

**STATE OF ILLINOIS
 DEPARTMENT OF TRANSPORTATION**

TYPICAL SECTIONS

SCALE: N.T.S. SHEET NO. 1 OF 2 SHEETS STA. TO STA.

F.A.P. RTE.	SECTION	COUNTY	TOTAL SHEETS	SHEET NO.
870	534X-RS-5	DUPAGE	35	4
FED. ROAD DIST. NO.			ILLINOIS FED. AID PROJECT	
			CONTRACT NO. 60N43	

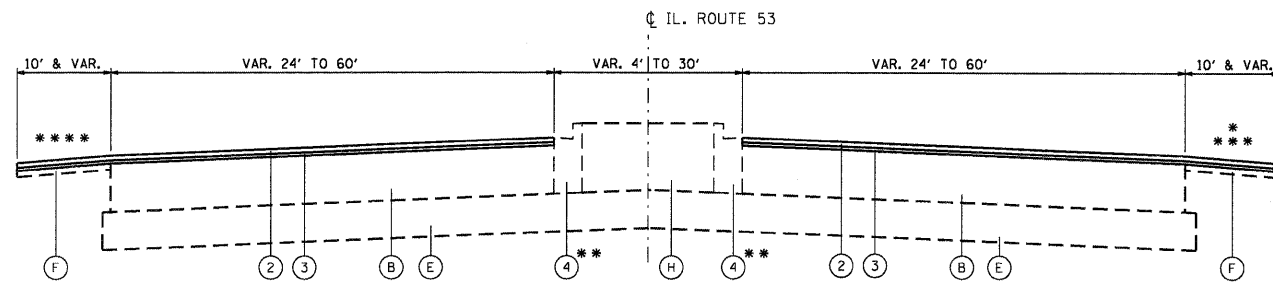

PROPOSED TYPICAL SECTION

STA. 13+61 TO STA. 58+42
 OMISSIONS AT STA. 13+61 TO STA. 15+55 (SB)
 STA. 27+24 TO STA. 27+58 (SB)
 STA. 27+32 TO STA. 27+66 (NB)
 STA. 34+54 TO STA. 36+49 (SB)
 STA. 34+83 TO STA. 36+83 (NB)
 * AGGREGATE SHOULDER STA. 46+61 TO STA. 58+42
 ** CURB & GUTTER ENDS AT STA. 44+50 RT.
 AND STA. 46+50 LT.
 *** CURB & GUTTER: STA. 38+20 TO STA. 41+80
 **** CURB & GUTTER: STA. 39+57 TO STA. 43+26

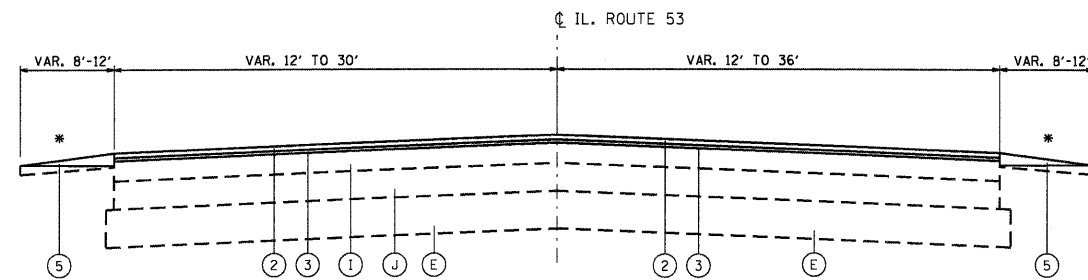

PROPOSED TYPICAL SECTION

STA. 58+42 TO STA. 98+75
 STA. 122+00 TO STA. 131+21
 STA. 136+20 TO STA. 158+21
 STA. 168+69 TO STA. 205+72
 * HMA SHOULDER STA. 58+42 TO STA. 63+52 LT.
 HMA SHOULDER STA. 92+61 TO STA. 98+75 RT.
 HMA SHOULDER STA. 147+69 TO STA. 149+23 LT.
 HMA SHOULDER STA. 149+15 TO STA. 149+80 RT.
 HMA SHOULDER STA. 173+25 TO STA. 178+53 RT.
 HMA SHOULDER STA. 183+00 TO STA. 183+91 RT.
 HMA SHOULDER STA. 190+74 TO STA. 191+35 RT.
 HMA SHOULDER STA. 192+89 TO STA. 194+54 RT.
 HMA SHOULDER STA. 195+59 TO STA. 196+43 LT.
 HMA SHOULDER STA. 195+96 TO STA. 199+63 RT.
 HMA SHOULDER STA. 201+44 TO STA. 202+59 RT.
 HMA MEDIAN STA. 202+59 TO STA. 205+72

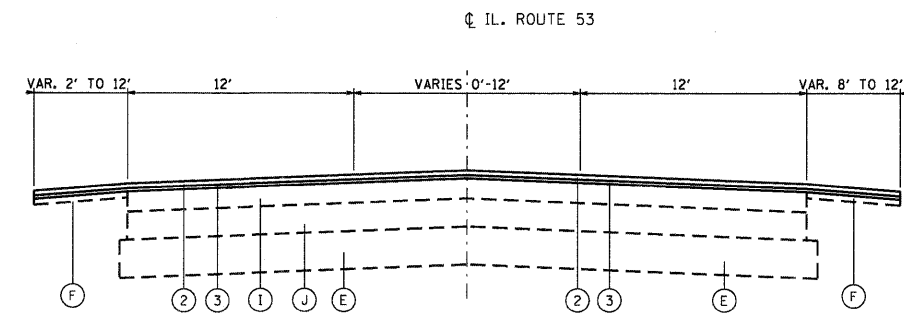

PROPOSED TYPICAL SECTION

STA. 131+21 TO STA. 136+20
 STA. 158+21 TO STA. 168+69

NOTES:

THE CONTRACTOR SHALL PATCH FIRST BEFORE MILLING FROM APPROXIMATELY STA. 13+61 TO STA. 56+40. THE CONTRACTOR SHALL MILL BEFORE PATCHING FROM STA. 56+40 TO STA. 202+59. SEE DISTRICT 1 DETAIL PAVEMENT PATCHING FOR HMA SURFACED PAVEMENT.

HOT-MIX ASPHALT MIXTURE REQUIREMENTS

MIXTURE TYPE	AIR VOIDS
PAVEMENT RESURFACING	
POLYMERIZED HOT-MIX ASPHALT SURFACE COURSE, MIX "F", N90 (IL-9.5mm)	4% @ 90 GYR.
POLYMERIZED LEVELING BINDER (MACHINE METHOD), IL-4.75, N50	4% @ 50 GYR.
HMA SHOULDER RESURFACING	
POLYMERIZED HOT-MIX ASPHALT SURFACE COURSE, MIX "F", N90 (IL-9.5mm)	4% @ 90 GYR.
POLYMERIZED LEVELING BINDER (MACHINE METHOD), IL-4.75, N50	4% @ 50 GYR.
PATCHING	
CLASS D PATCHES (HMA BINDER, IL-19mm)	4% @ 70 GYR.
HMA REPLACEMENT OVER PATCHES (HMA BINDER IL-19mm)	4% @ 70 GYR.
DRIVEWAYS	
HMA SURFACE COURSE, MIX "D", N 50 (IL 9.5 mm); 2"	4% @ 50 GYR.
HMA BASE COURSE (HMA BINDER IL-19mm); PE -6", CE -8"	4% @ 50 GYR.

THE UNIT WEIGHT TO CALCULATE ALL HMA SURFACE MIXTURE QUANTITIES IS 112 LBS/50 YD³/IN

THE "AC TYPE" FOR POLYMERIZED HMA MIXES SHALL BE "SBS/SBR PG 76-22" AND FOR NON-POLYMERIZED HMA THE "AC TYPE" SHALL BE "PG 64-22" UNLESS MODIFIED BY DISTRICT ONE SPECIAL PROVISIONS.

FOR "PERCENT OF RAP" SEE SPECIAL PROVISIONS.

PAY FOR PERFORMANCE SPECIFICATION SHALL ONLY APPLY TO THE POLYMERIZED HMA SURFACE COURSE, MIX "F", N90.

EXISTING CONDITIONS

- (A) HMA RESURFACING, ±2 1/4"
- (B) PCC PAVEMENT, ±10"
- (C) COMBINATION CONCRETE CURB AND GUTTER
- (D) AGGREGATE SHOULDERS
- (E) AGGREGATE BASE COURSE
- (F) HMA SHOULDERS
- (H) CONCRETE MEDIAN / GRASS MEDIAN
- (I) HMA RESURFACING, ±8"
- (J) PCC PAVEMENT, ±8"

PROPOSED IMPROVEMENTS

- (1) HOT-MIX ASPHALT SURFACE REMOVAL, 2 1/2"
- (2) POLYMERIZED HOT-MIX ASPHALT SURFACE COURSE, MIX "F", N90, 1 3/4"
- (3) POLYMERIZED LEVELING BINDER (MACHINE METHOD), IL-4.75, N50, 3/4"
- (4) COMBINATION CONCRETE CURB & GUTTER REMOVAL AND REPLACEMENT (AT LOCATIONS AS DETERMINED BY THE ENGINEER)
- (5) AGGREGATE WEDGE SHOULDER, TYPE B (TAPER 3" TO 1" THICKNESS)

COMPANY NAME: HRGreen.com
 PROJECT CONTACT: SPernal
 CLIENT: HRGreen
 DATE PLOTTED: 10/24/2011 3:32:20 PM
 FILE NAME: 86100196.06-1yp-02.dgn
 PLOT DRIVER: pdf.plt
 PEN TABLE: standard-trans.tbl



USER NAME = SPernal	DESIGNED - J. ROITBURD	REVISED -
PLOT SCALE = N.T.S.	DRAWN - R. BEST	REVISED -
PLOT DATE = 10/24/2011	CHECKED - T. HAMILTON	REVISED -
	DATE - 10/24/11	REVISED -

**STATE OF ILLINOIS
 DEPARTMENT OF TRANSPORTATION**

TYPICAL SECTIONS

SCALE: N.T.S. SHEET NO. 2 OF 2 SHEETS STA. TO STA.

F.A.P. RTE. 870	SECTION 534X-RS-5	COUNTY DUPAGE	TOTAL SHEETS 35	SHEET NO. 5
FED. ROAD DIST. NO. ILLINOIS FED. AID PROJECT			CONTRACT NO. 60N43	

INTERSTATE 88

PROJECT BEGINS STA. 15+55

IL RTE 53

HMA SURF REM 2 1/2
P HMA SC "F" N90, 1 1 3/4"
P LEV BIND MM, IL-4.75, N50, 3/4"

MATCHLINE STA. 18+00

PROJECT BEGINS STA. 13+61



BRIDGE OMISSION STA. 27+24 TO STA. 27+58

INDIAN HILL DR.

HMA SURF REM 2 1/2
P HMA SC "F" N90, 1 1 3/4"
P LEV BIND MM, IL-4.75, N50, 3/4"

IL RTE 53

HMA SURF REM 2 1/2
P HMA SC "F" N90, 1 1 3/4"
P LEV BIND MM, IL-4.75, N50, 3/4"

MATCHLINE STA. 18+00

25 LIN FT
COMB C C&G REM & REPL

HMA SURF REM 2 1/2
P HMA SC "F" N90, 1 1 3/4"
P LEV BIND MM, IL-4.75, N50, 3/4"

BUTT JOINT (TYP.)

LEGEND

- EXISTING INLET
- EXISTING CATCH BASIN
- ⊙ EXISTING MANHOLE
- E ELECTRIC
- W WATER
- CE COM ED (ADJUSTMENTS PERFORMED BY OTHERS)
- T TELEPHONE (ADJUSTMENTS PERFORMED BY OTHERS)
- G GAS
- SP FRAMES AND LIDS TO BE ADJUSTED, SPECIAL
- C DRAINAGE STRUCTURES TO BE CLEANED
- ADJ FRAMES AND LIDS TO BE ADJUSTED
- REC DRAINAGE STRUCTURES TO BE RECONSTRUCTED
- UNIT TREE REMOVAL

BRIDGE OMISSION STA. 27+32 TO STA. 27+66

MATCHLINE STA. 33+00

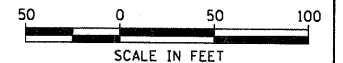

COMPANY NAME: HRGreen
 PROJECT CONTACT: SPernall
 CLIENT: HRGreen
 DATE PLOTTED: 10/24/2011 2:32:23 PM
 FILE NAME: 8600196.06-plan-01.dgn
 PLOT DRIVER: pdf.plt
 PEN TABLE: standard-trans.tbl



USER NAME = SPernall
PLOT SCALE = 1" = 50'
PLOT DATE = 10/24/2011

DESIGNED - J. ROITBURD	REVISED -
DRAWN - R. BEST	REVISED -
CHECKED - T. HAMILTON	REVISED -
DATE - 10/24/11	REVISED -

STATE OF ILLINOIS
DEPARTMENT OF TRANSPORTATION

ROADWAY PLAN
ILLINOIS ROUTE 53 (WARRENVILLE RD. TO IL RTE. 38)

SCALE: 1" = 50' SHEET NO. 1 OF 7 SHEETS STA. BEGIN TO STA. 33+00

F.A.P. RTE.	SECTION	COUNTY	TOTAL SHEETS	SHEET NO.
870	534X-RS-5	DUPAGE	35	6
CONTRACT NO. 60N43				

FED. ROAD DIST. NO. ILLINOIS FED. AID PROJECT

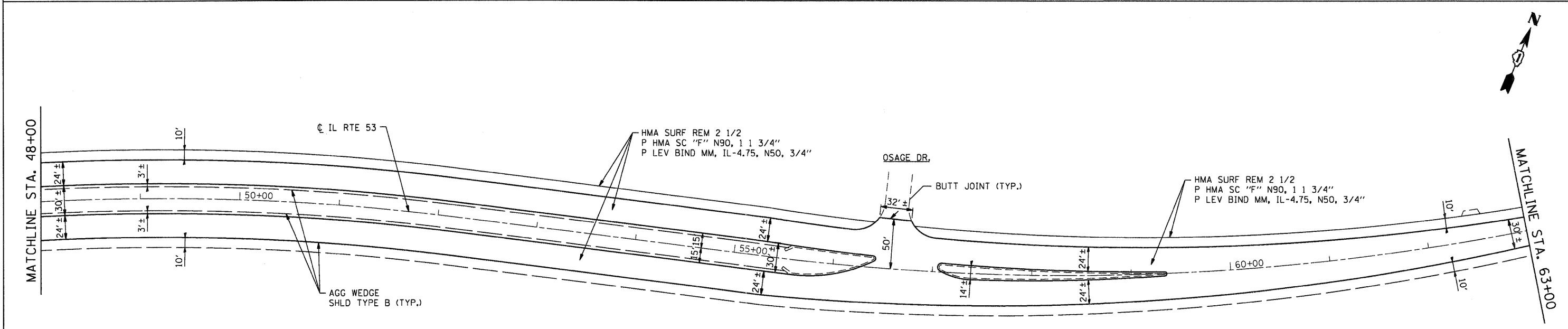
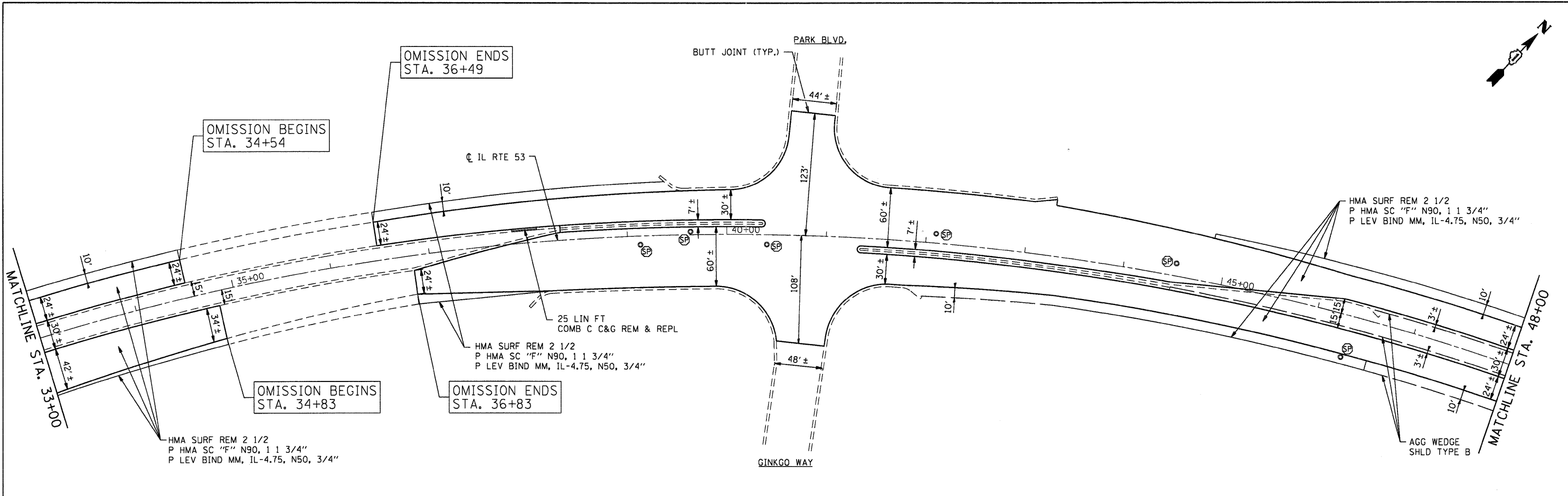

- LEGEND**
- EXISTING INLET
 - EXISTING CATCH BASIN
 - ⊙ EXISTING MANHOLE
 - E ELECTRIC
 - W WATER
 - CE COM ED (ADJUSTMENTS PERFORMED BY OTHERS)
 - T TELEPHONE (ADJUSTMENTS PERFORMED BY OTHERS)
 - G GAS
 - ⊕ FRAMES AND LIDS TO BE ADJUSTED, SPECIAL
 - DRAINAGE STRUCTURES TO BE CLEANED
 - ADJ FRAMES AND LIDS TO BE ADJUSTED
 - REC DRAINAGE STRUCTURES TO BE RECONSTRUCTED
 - ⊕ UNIT TREE REMOVAL

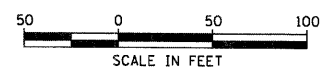

COMPANY NAME: HRGreen.com
 PROJECT CONTACT: HRGreen.com
 CLIENT: HRGreen.com
 DATE PLOTTED: 10/24/2011 2:32:25 PM
 FILE NAME: 86100196.06-pion-02.dgn
 PLOT DRIVER: pdfplot
 PEN TABLE: standard-trans.tbl



USER NAME = SPernal	DESIGNED - J. ROITBURD	REVISED -
PLOT SCALE = 1" = 50'	DRAWN - R. BEST	REVISED -
PLOT DATE = 10/24/2011	CHECKED - T. HAMILTON	REVISED -
	DATE - 10/24/11	REVISED -

**STATE OF ILLINOIS
 DEPARTMENT OF TRANSPORTATION**

**ROADWAY PLAN
 ILLINOIS ROUTE 53 (WARRENVILLE RD. TO IL RTE. 38)**

SCALE: 1" = 50' SHEET NO. 2 OF 7 SHEETS STA. 33+00 TO STA. 63+00

F.A.P. RTE. 870	SECTION 534X-RS-5	COUNTY DUPAGE	TOTAL SHEETS 35	SHEET NO. 7
FED. ROAD DIST. NO.			ILLINOIS FED. AID PROJECT	
CONTRACT NO. 60N43				

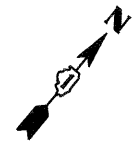
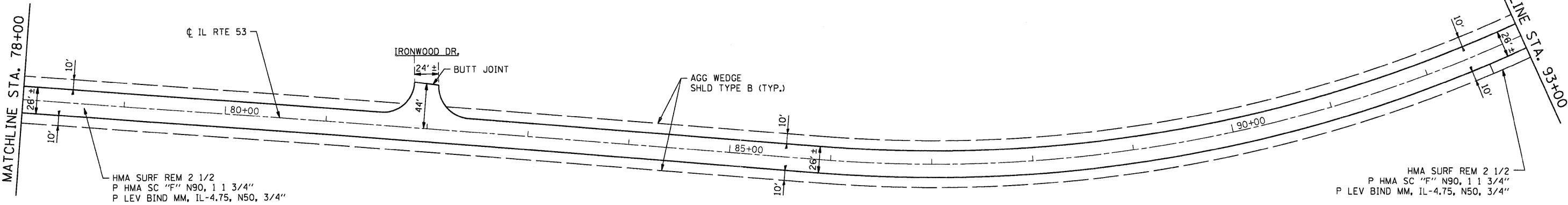
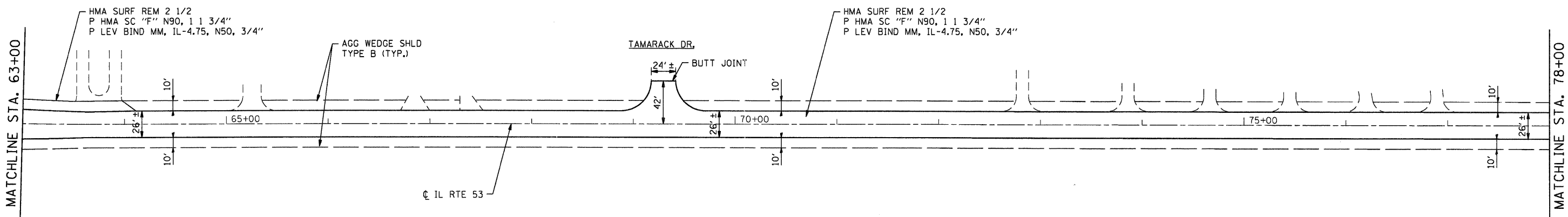
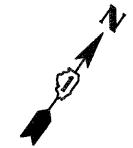

- LEGEND**
- EXISTING INLET
 - EXISTING CATCH BASIN
 - ⊙ EXISTING MANHOLE
 - E ELECTRIC
 - W WATER
 - CE COM ED (ADJUSTMENTS PERFORMED BY OTHERS)
 - T TELEPHONE (ADJUSTMENTS PERFORMED BY OTHERS)
 - G GAS
 - ⊕ FRAMES AND LIDS TO BE ADJUSTED, SPECIAL
 - DRAINAGE STRUCTURES TO BE CLEANED
 - ADJ FRAMES AND LIDS TO BE ADJUSTED
 - REC DRAINAGE STRUCTURES TO BE RECONSTRUCTED
 - ⊗ UNIT TREE REMOVAL

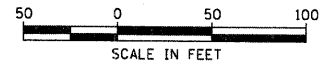

COMPANY NAME: HRCGreen
 PROJECT CONTACT: #PROJECT_CONTACT1
 CLIENT: #CLIENT
 DATE PLOTTED: 10/24/2011 2:32:28 PM
 FILE NAME: 86100196-05-plan-03.dgn
 PLOT DRIVER: pcf.plt
 PEN TABLE: standard-trans.tbl



USER NAME = SParnal	DESIGNED - J. ROITBURD	REVISED -
	DRAWN - R. BEST	REVISED -
PLOT SCALE = 1" = 50'	CHECKED - T. HAMILTON	REVISED -
PLOT DATE = 10/24/2011	DATE - 10/24/11	REVISED -

**STATE OF ILLINOIS
 DEPARTMENT OF TRANSPORTATION**

ROADWAY PLAN
ILLINOIS ROUTE 53 (WARRENVILLE RD. TO IL RTE. 38)
 SCALE: 1" = 50' SHEET NO. 3 OF 7 SHEETS STA. 63+00 TO STA. 93+00

F.A.P. RTE.	SECTION	COUNTY	TOTAL SHEETS	SHEET NO.
870	534X-RS-5	DUPAGE	35	8
FED. ROAD DIST. NO. ILLINOIS FED. AID PROJECT			CONTRACT NO. 60N43	

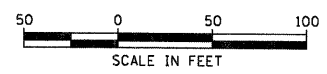
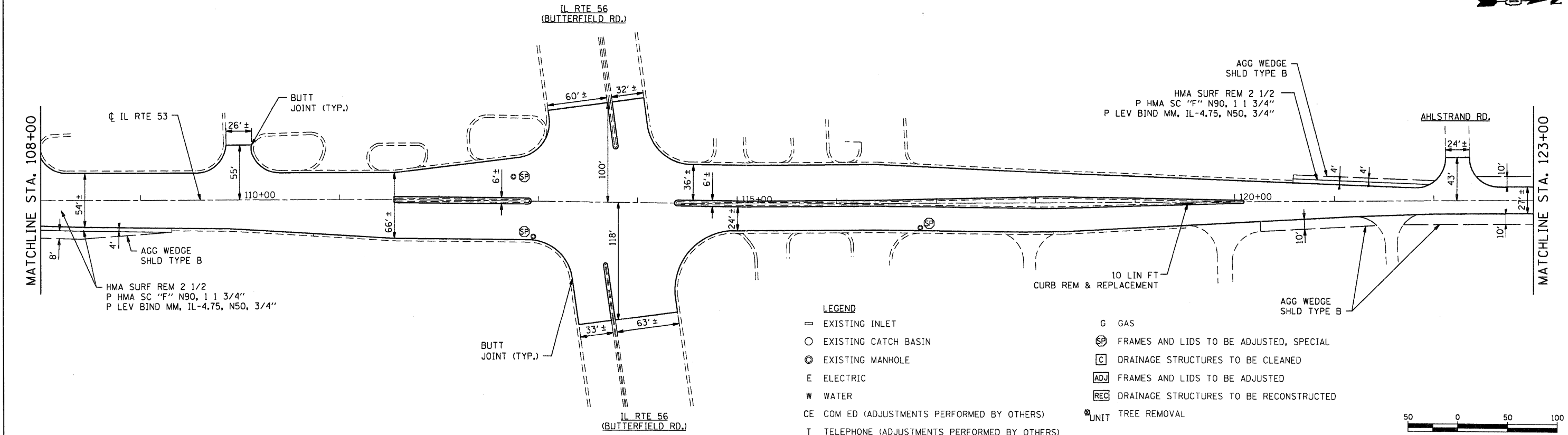
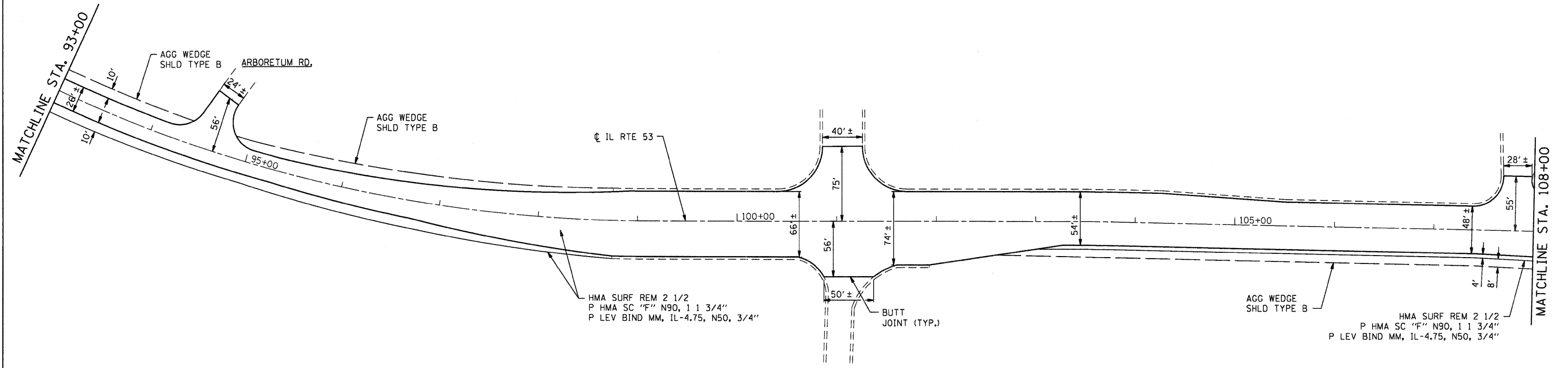

COMPANY NAME: HRGreen.com
 PROJECT CONTACT: #PROJECT CONTACT
 CLIENT: #CLIENT
 DATE PLOTTED: 10/24/2011 2:32:30 PM
 FILE NAME: 86100196-06-plan-04.dgn
 PLOT DRIVER: pdfLdt
 PEN TABLE: s:\standard-trans.tbl



USER NAME = SPernal	DESIGNED - J. ROITBURD	REVISED -
PLOT SCALE = 1" = 50'	DRAWN - R. BEST	REVISED -
PLOT DATE = 10/24/2011	CHECKED - T. HAMILTON	REVISED -
	DATE - 10/24/11	REVISED -

**STATE OF ILLINOIS
 DEPARTMENT OF TRANSPORTATION**

**ROADWAY PLAN
 ILLINOIS ROUTE 53 (WARRENVILLE RD. TO IL RTE. 38)**

SCALE: 1" = 50' SHEET NO. 4 OF 7 SHEETS STA. 93+00 TO STA. 123+00

F.A.P. RTE. B70	SECTION 534X-RS-5	COUNTY DUPAGE	TOTAL SHEETS 35	SHEET NO. 9
FED. ROAD DIST. NO.		ILLINOIS FED. AID PROJECT		
		CONTRACT NO. 60N43		

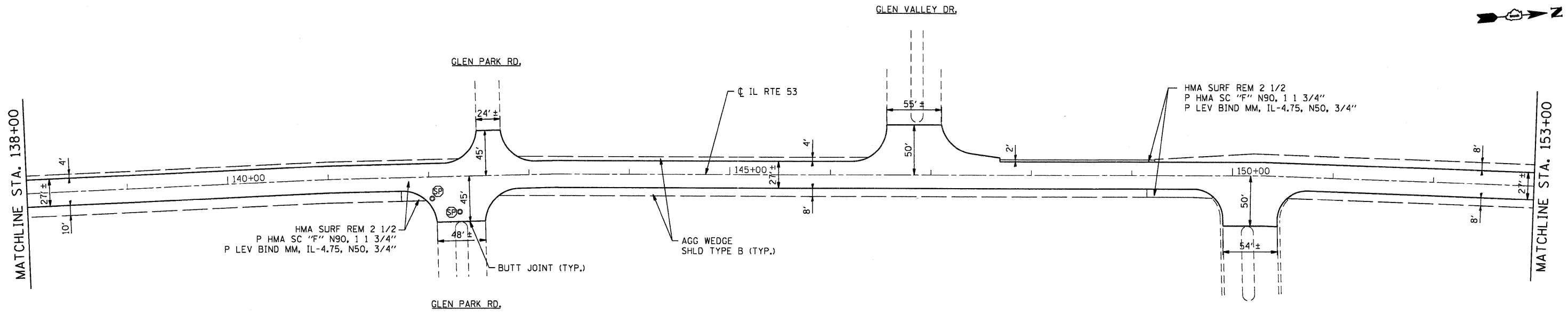
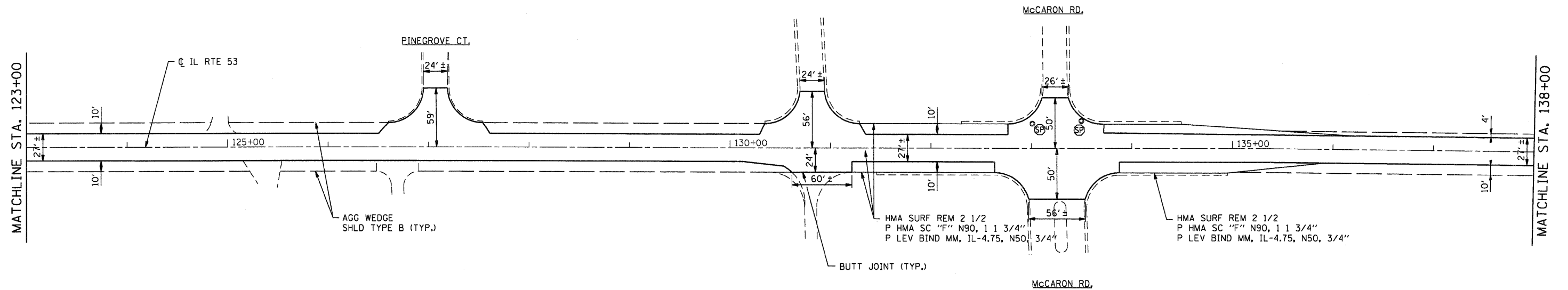

LEGEND

- ⊖ EXISTING INLET
- EXISTING CATCH BASIN
- ⊙ EXISTING MANHOLE
- E ELECTRIC
- W WATER
- CE COM ED (ADJUSTMENTS PERFORMED BY OTHERS)
- T TELEPHONE (ADJUSTMENTS PERFORMED BY OTHERS)
- G GAS
- ⊕ FRAMES AND LIDS TO BE ADJUSTED, SPECIAL
- ⊔ DRAINAGE STRUCTURES TO BE CLEANED
- ⊕ FRAMES AND LIDS TO BE ADJUSTED
- ⊔ DRAINAGE STRUCTURES TO BE RECONSTRUCTED
- ⊕ UNIT TREE REMOVAL

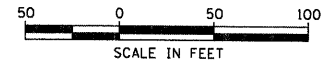

COMPANY NAME: HRGreen
 PROJECT CONTACT: #PROJECT_CONTACT1
 CLIENT: #CLIENT
 DATE PLOTTED: 10/24/2011 2:32:33 PM
 FILE NAME: 86100196.06-plan-05.dgn
 PLOT DRIVER: pdfplot
 PEN TABLE: standard-trans.tbl



USER NAME = SPernol	DESIGNED - J. ROITBURD	REVISED -
	DRAWN - R. BEST	REVISED -
PLOT SCALE = 1" = 50'	CHECKED - T. HAMILTON	REVISED -
PLOT DATE = 10/24/2011	DATE - 10/24/11	REVISED -

**STATE OF ILLINOIS
DEPARTMENT OF TRANSPORTATION**

**ROADWAY PLAN
ILLINOIS ROUTE 53 (WARRENVILLE RD. TO IL RTE. 38)**

SCALE: 1" = 50' SHEET NO. 5 OF 7 SHEETS STA. 123+00 TO STA. 153+00

F.A.P. RTE.	SECTION	COUNTY	TOTAL SHEETS	SHEET NO.
870	534X-RS-5	DUPAGE	35	10
FED. ROAD DIST. NO.			ILLINOIS FED. AID PROJECT	
			CONTRACT NO. 60N43	

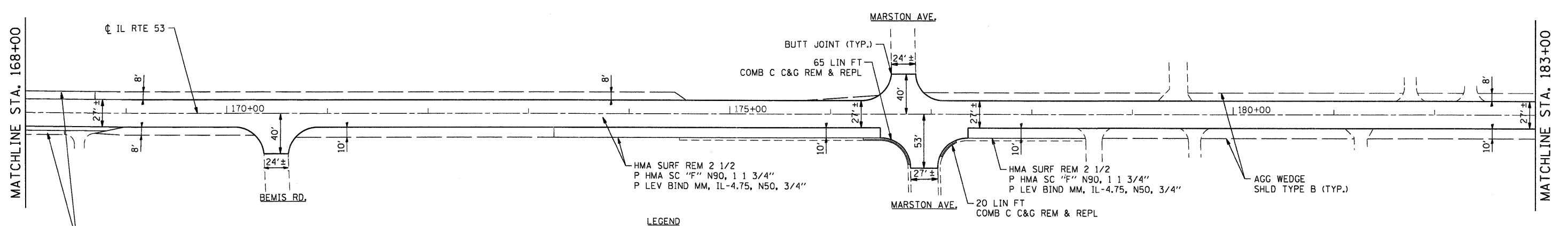
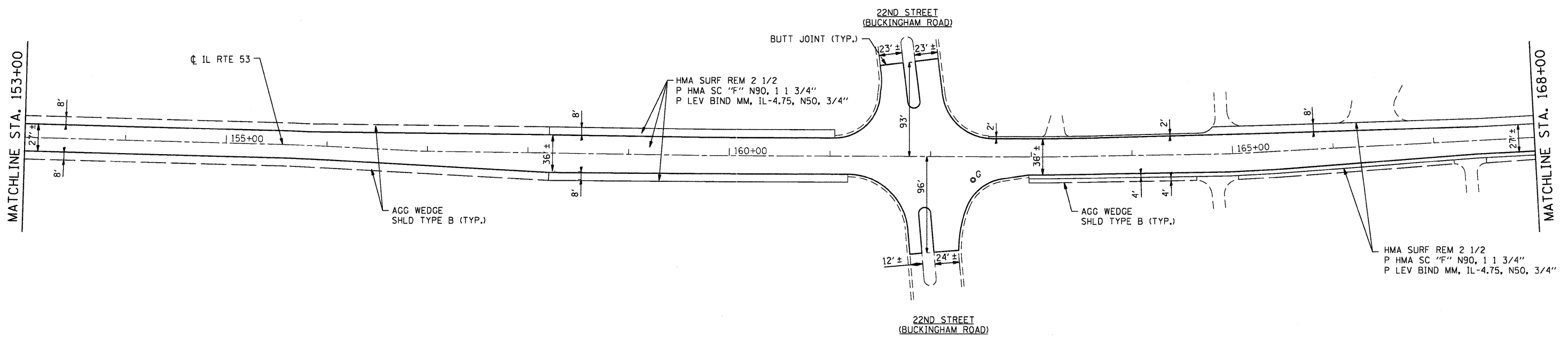

- LEGEND**
- ◻ EXISTING INLET
 - EXISTING CATCH BASIN
 - ⊙ EXISTING MANHOLE
 - E ELECTRIC
 - W WATER
 - CE COM ED (ADJUSTMENTS PERFORMED BY OTHERS)
 - T TELEPHONE (ADJUSTMENTS PERFORMED BY OTHERS)
 - G GAS
 - ⊕ FRAMES AND LIDS TO BE ADJUSTED, SPECIAL
 - ⊓ DRAINAGE STRUCTURES TO BE CLEANED
 - ADJ FRAMES AND LIDS TO BE ADJUSTED
 - REC DRAINAGE STRUCTURES TO BE RECONSTRUCTED
 - UNIT TREE REMOVAL

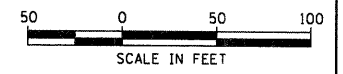

COMPANY NAME: HRGreen.com
 PROJECT CONTACT: J. ROITBURD
 DATE PLOTTED: 10/24/2011 2:32:35 PM
 FILE NAME: 86100196.06-plan-06.dgn
 PLOT DRIVER: pdt.plt
 PEN TABLE: standard-trans.tbl

HRGreen.com
 Illinois Professional Design Firm
 #184-001322

USER NAME = SPernal	DESIGNED - J. ROITBURD	REVISED -
PLOT SCALE = 1" = 50'	DRAWN - R. BEST	REVISED -
PLOT DATE = 10/24/2011	CHECKED - T. HAMILTON	REVISED -
	DATE - 10/24/11	REVISED -

**STATE OF ILLINOIS
 DEPARTMENT OF TRANSPORTATION**

**ROADWAY PLAN
 ILLINOIS ROUTE 53 (WARRENVILLE RD. TO IL RTE. 38)**

SCALE: 1" = 50' SHEET NO. 6 OF 7 SHEETS STA. 153+00 TO STA. 183+00

F.A.P. RTE.	SECTION	COUNTY	TOTAL SHEETS	SHEET NO.
870	534X-RS-5	DUPAGE	35	11
FED. ROAD DIST. NO.			ILLINOIS FED. AID PROJECT	

CONTRACT NO. 60N43

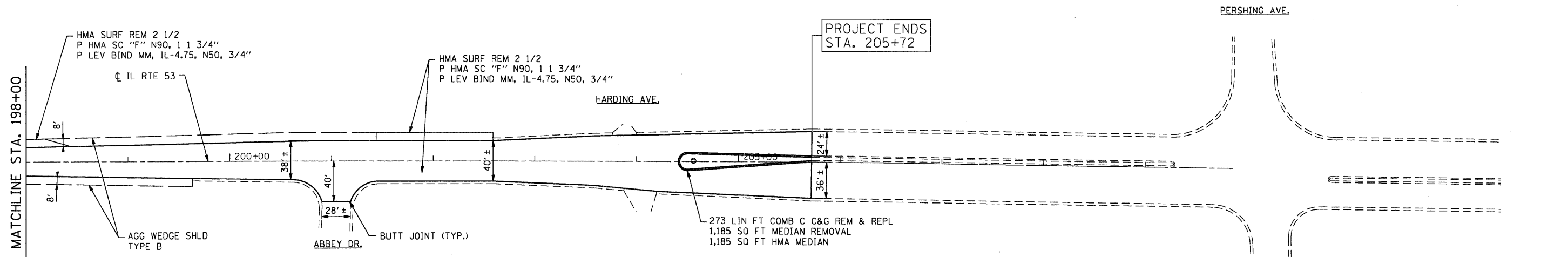
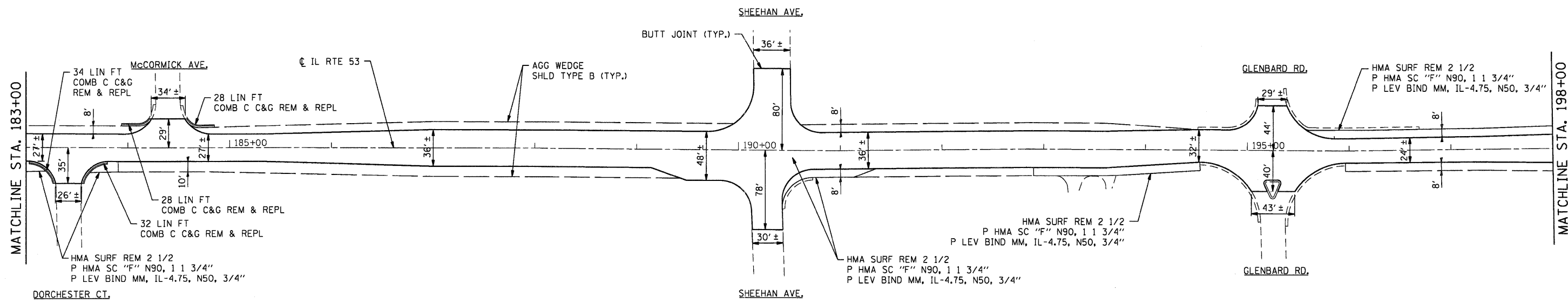

- LEGEND**
- EXISTING INLET
 - EXISTING CATCH BASIN
 - ⊙ EXISTING MANHOLE
 - E ELECTRIC
 - W WATER
 - CE COM ED (ADJUSTMENTS PERFORMED BY OTHERS)
 - T TELEPHONE (ADJUSTMENTS PERFORMED BY OTHERS)
 - G GAS
 - ⊕ FRAMES AND LIDS TO BE ADJUSTED, SPECIAL
 - ⊔ DRAINAGE STRUCTURES TO BE CLEANED
 - ADJ FRAMES AND LIDS TO BE ADJUSTED
 - REC DRAINAGE STRUCTURES TO BE RECONSTRUCTED
 - ⊗ UNIT TREE REMOVAL

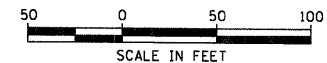

COMPANY NAME: HRGreen.com
 PROJECT CONTACT: J. ROITBURD
 CLIENT CONTACT: R. BEST
 DATE PLOTTED: 10/24/2011 2:42:37 PM
 FILE NAME: 86100196.06-plan-01.dgn
 PLOT DRIVER: pcf.plt
 PEN TABLE: standard-trans.tbl



USER NAME = SPernal	DESIGNED - J. ROITBURD	REVISED -
PLOT SCALE = 1" = 50'	DRAWN - R. BEST	REVISED -
PLOT DATE = 10/24/2011	CHECKED - T. HAMILTON	REVISED -
	DATE - 10/24/11	REVISED -

**STATE OF ILLINOIS
 DEPARTMENT OF TRANSPORTATION**

**ROADWAY PLAN
 ILLINOIS ROUTE 53 (WARRENVILLE RD. TO IL RTE. 38)**

SCALE: 1" = 50' SHEET NO. 7 OF 7 SHEETS STA. 183+00 TO STA. END

F.A.P. RTE.	SECTION	COUNTY	TOTAL SHEETS	SHEET NO.
870	534X-RS-5	DUPAGE	35	12
FED. ROAD DIST. NO.			ILLINOIS FED. AID PROJECT	
			CONTRACT NO. 60N43	

INTERSTATE 88



PROJECT BEGINS
STA. 15+55
MATCH EXISTING
PAVEMENT MARKINGS

IL RTE 53

PROJECT BEGINS
STA. 13+61
MATCH EXISTING
PAVEMENT MARKINGS

MATCHLINE STA. 18+00

INDIAN HILL DR.

BRIDGE OMISSION
STA. 27+24 TO STA. 27+58

BRIDGE OMISSION
STA. 27+32 TO STA. 27+66



MATCHLINE STA. 18+00

MATCHLINE STA. 33+00

LEGEND	
1	LINE 4" (YELLOW SOLID LINE)
2	LINE 4" (DOUBLE YELLOW SOLID LINES)
3	LINE 4" (YELLOW - 10' DASH, 30' SKIP)
4	LINE 4" (WHITE LANE LINE - 10' DASH, 30' SKIP)
5	LINE 4" (WHITE SOLID LINE)
6	LINE 6" (WHITE SOLID LINE)
7	LINE 6" (WHITE LANE LINE - 2' DASH, 6' SKIP)
8	LINE 8" (WHITE SOLID LINE)
9	LINE 12" (WHITE SOLID LINE)
10	LINE 12" (WHITE DIAGONAL LINE)
11	LINE 12" (YELLOW DIAGONAL LINE)
12	LINE 24" (WHITE SOLID LINE)
13	LETTERS AND SYMBOLS (TYP.)

NOTES:
1. ALL PAVEMENT MARKINGS SHALL BE THERMOPLASTIC UNLESS OTHERWISE SPECIFIED.
2. RAISED REFLECTIVE PAVEMENT MARKERS SHALL BE USED THROUGHOUT THE PROJECT LIMITS. SEE DISTRICT DETAIL TC-11.



COMPANY NAME: HRGreen.com
PROJECT CONTACT: #PROJECT_CONTACT1
CLIENT: ILLINOIS DEPARTMENT OF TRANSPORTATION
FILE NAME: 86100196.06-pm-01.dgn
PLOT DRIVER: pdf.plt
PEN TABLE: standard-trans.tbl



USER NAME = SPernal	DESIGNED - J. ROITBURD	REVISED -
PLOT SCALE = 1" = 50'	DRAWN - R. BEST	REVISED -
PLOT DATE = 10/25/2011	CHECKED - T. HAMILTON	REVISED -
	DATE - 10/25/11	REVISED -

STATE OF ILLINOIS
DEPARTMENT OF TRANSPORTATION

PAVEMENT MARKING PLAN
ILLINOIS ROUTE 53 (WARRENVILLE RD. TO IL RTE. 38)

SCALE: 1" = 50' SHEET NO. 1 OF 7 SHEETS STA. BEGIN TO STA. 33+00

F.A.P. RTE.	SECTION	COUNTY	TOTAL SHEETS	SHEET NO.
870	534X-RS-5	DUPAGE	35	13
CONTRACT NO. 60N43			FED. ROAD DIST. NO. [ILLINOIS] FED. AID PROJECT	

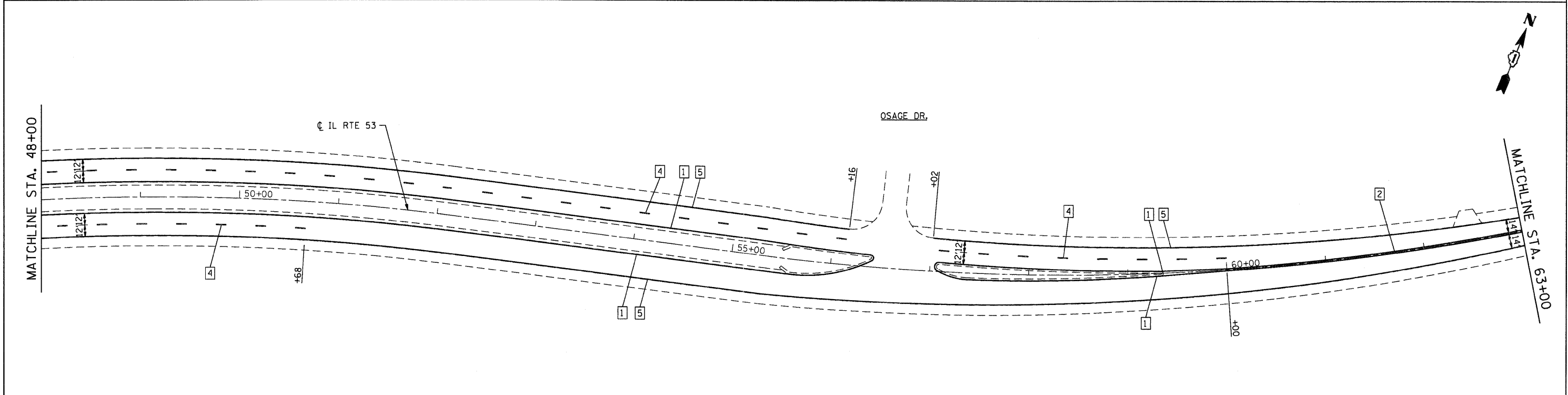
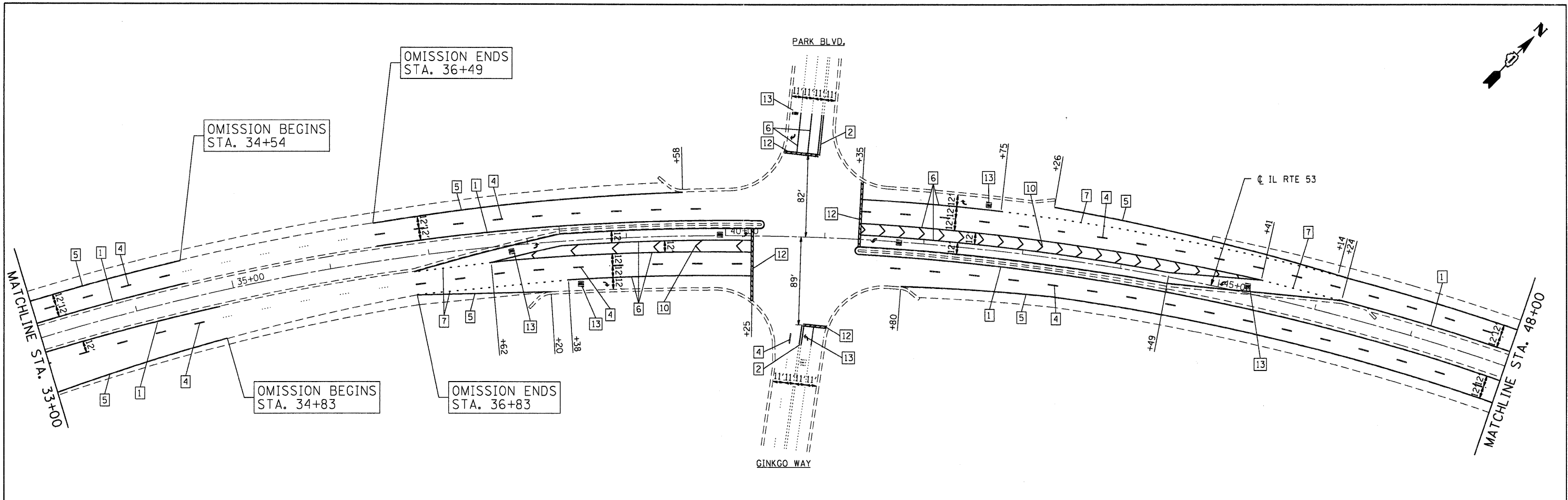

LEGEND			NOTES:		
1	LINE 4" (YELLOW SOLID LINE)	5	LINE 4" (WHITE SOLID LINE)	10	LINE 12" (WHITE DIAGONAL LINE)
2	LINE 4" (DOUBLE YELLOW SOLID LINES)	6	LINE 6" (WHITE SOLID LINE)	11	LINE 12" (YELLOW DIAGONAL LINE)
3	LINE 4" (YELLOW - 10' DASH, 30' SKIP)	7	LINE 6" (WHITE LANE LINE - 2' DASH, 6' SKIP)	12	LINE 24" (WHITE SOLID LINE)
4	LINE 4" (WHITE LANE LINE - 10' DASH, 30' SKIP)	8	LINE 8" (WHITE SOLID LINE)	13	LETTERS AND SYMBOLS (TYP.)
		9	LINE 12" (WHITE SOLID LINE)		

1. ALL PAVEMENT MARKINGS SHALL BE THERMOPLASTIC UNLESS OTHERWISE SPECIFIED.
 2. RAISED REFLECTIVE PAVEMENT MARKERS SHALL BE USED THROUGHOUT THE PROJECT LIMITS. SEE DISTRICT DETAIL TC-11.

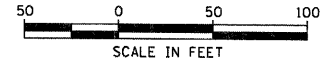

COMPANY NAME: HRGreen.com
 PROJECT CONTACT: #PROJECT CONTACT
 CLIENT: #CLIENT
 DATE PLOTTED: 10/25/2011 6:24:49 PM
 FILE NAME: 86100196_06-pm-02.dgn
 PLOT DRIVER: pdfLaf
 PEN TABLE: standard-trans.tbl



USER NAME = SPernal	DESIGNED - J. ROITBURD	REVISED -
PLOT SCALE = 1" = 50'	DRAWN - R. BEST	REVISED -
PLOT DATE = 10/25/2011	CHECKED - T. HAMILTON	REVISED -
	DATE - 10/25/11	REVISED -

**STATE OF ILLINOIS
 DEPARTMENT OF TRANSPORTATION**

**PAVEMENT MARKING PLAN
 ILLINOIS ROUTE 53 (WARRENVILLE RD. TO IL RTE. 38)**
 SCALE: 1" = 50' SHEET NO. 2 OF 7 SHEETS STA. 33+00 TO STA. 63+00

F.A.P. RTE.	SECTION	COUNTY	TOTAL SHEETS	SHEET NO.
870	534X-RS-5	DUPAGE	35	14
FED. ROAD DIST. NO. ILLINOIS FED. AID PROJECT			CONTRACT NO. 60N43	

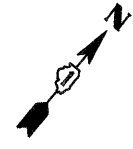
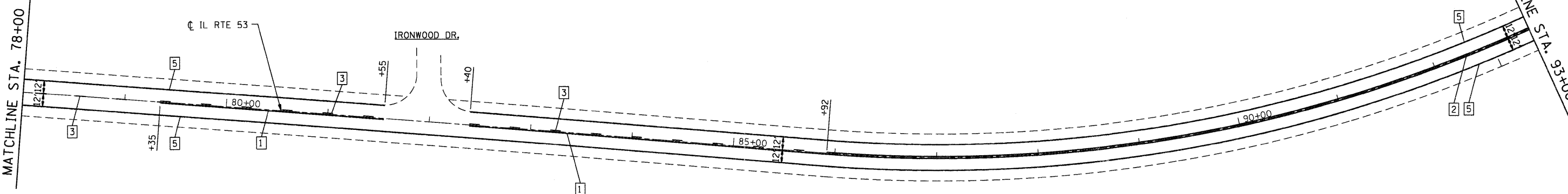
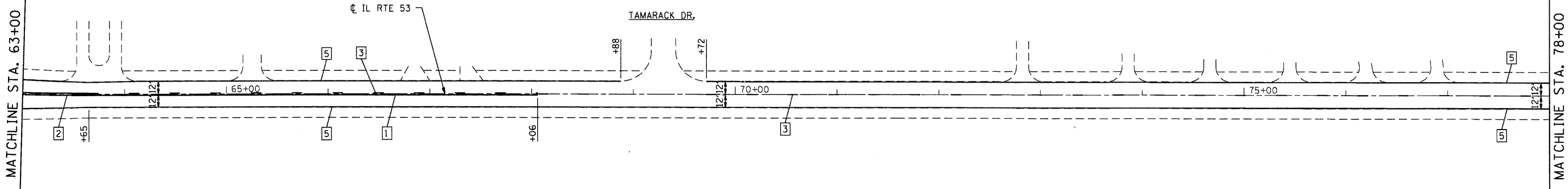
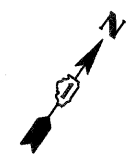

LEGEND	
1	LINE 4" (YELLOW SOLID LINE)
2	LINE 4" (DOUBLE YELLOW SOLID LINES)
3	LINE 4" (YELLOW - 10' DASH, 30' SKIP)
4	LINE 4" (WHITE LANE LINE - 10' DASH, 30' SKIP)
5	LINE 4" (WHITE SOLID LINE)
6	LINE 6" (WHITE SOLID LINE)
7	LINE 6" (WHITE LANE LINE - 2' DASH, 6' SKIP)
8	LINE 8" (WHITE SOLID LINE)
9	LINE 12" (WHITE SOLID LINE)
10	LINE 12" (WHITE DIAGONAL LINE)
11	LINE 12" (YELLOW DIAGONAL LINE)
12	LINE 24" (WHITE SOLID LINE)
13	LETTERS AND SYMBOLS (TYP.)

NOTES:

1. ALL PAVEMENT MARKINGS SHALL BE THERMOPLASTIC UNLESS OTHERWISE SPECIFIED.
2. RAISED REFLECTIVE PAVEMENT MARKERS SHALL BE USED THROUGHOUT THE PROJECT LIMITS. SEE DISTRICT DETAIL TC-11.

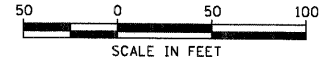

COMPANY NAME: HRGreen.com
 PROJECT CONTACT: #PROJECT_CONTACT
 CLIENT: #CLIENT
 DATE PLOTTED: 10/25/2011 6:22:53 PM
 FILE NAME: 86100196_06-pm-03.dgn
 PLOT DRIVER: perf.dwt
 PLOT TABLE: standard-trans.tbl



USER NAME = SPernal	DESIGNED - J. ROITBURD	REVISED -
	DRAWN - R. BEST	REVISED -
PLOT SCALE = 1" = 50'	CHECKED - T. HAMILTON	REVISED -
PLOT DATE = 10/25/2011	DATE - 10/25/11	REVISED -

**STATE OF ILLINOIS
DEPARTMENT OF TRANSPORTATION**

**PAVEMENT MARKING PLAN
ILLINOIS ROUTE 53 (WARRENVILLE RD. TO IL RTE. 38)**

SCALE: 1" = 50' SHEET NO. 3 OF 7 SHEETS STA. 63+00 TO STA. 93+00

F.A.P. RTE.	SECTION	COUNTY	TOTAL SHEETS	SHEET NO.
870	534X-RS-5	DUPAGE	35	15
FED. ROAD DIST. NO. ILLINOIS FED. AID PROJECT			CONTRACT NO. 60N43	

- LEGEND**
- | | | |
|--|--|------------------------------------|
| 1 LINE 4" (YELLOW SOLID LINE) | 5 LINE 4" (WHITE SOLID LINE) | 10 LINE 12" (WHITE DIAGONAL LINE) |
| 2 LINE 4" (DOUBLE YELLOW SOLID LINES) | 6 LINE 6" (WHITE SOLID LINE) | 11 LINE 12" (YELLOW DIAGONAL LINE) |
| 3 LINE 4" (YELLOW - 10' DASH, 30' SKIP) | 7 LINE 6" (WHITE LANE LINE - 2' DASH, 6' SKIP) | 12 LINE 24" (WHITE SOLID LINE) |
| 4 LINE 4" (WHITE LANE LINE - 10' DASH, 30' SKIP) | 8 LINE 8" (WHITE SOLID LINE) | 13 LETTERS AND SYMBOLS (TYP.) |
| | 9 LINE 12" (WHITE SOLID LINE) | |

- NOTES:**
- ALL PAVEMENT MARKINGS SHALL BE THERMOPLASTIC UNLESS OTHERWISE SPECIFIED.
 - RAISED REFLECTIVE PAVEMENT MARKERS SHALL BE USED THROUGHOUT THE PROJECT LIMITS. SEE DISTRICT DETAIL TC-11.

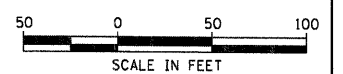
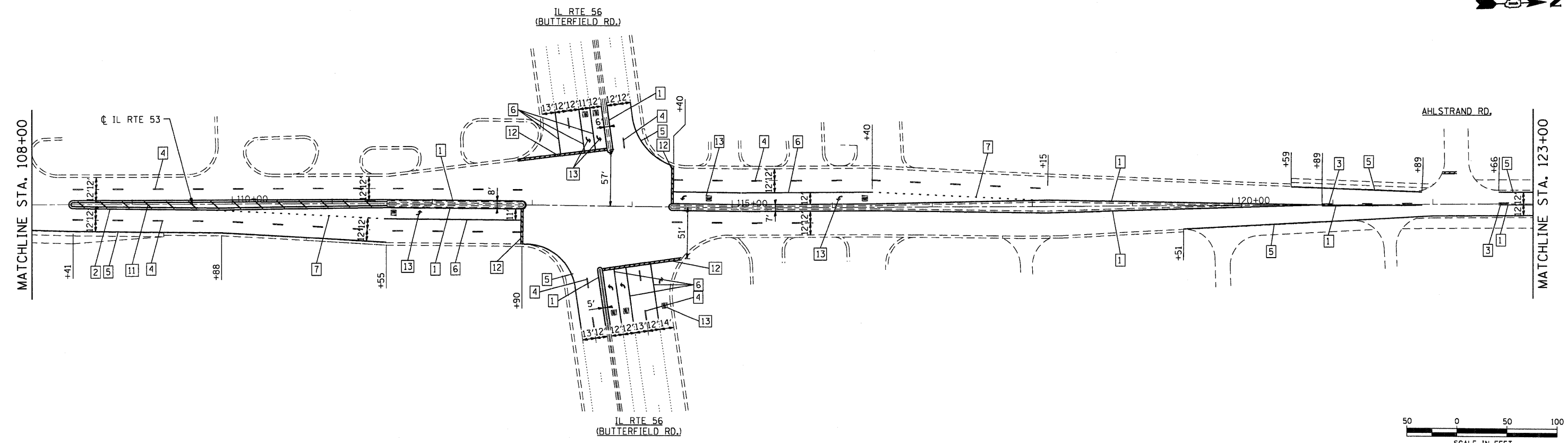
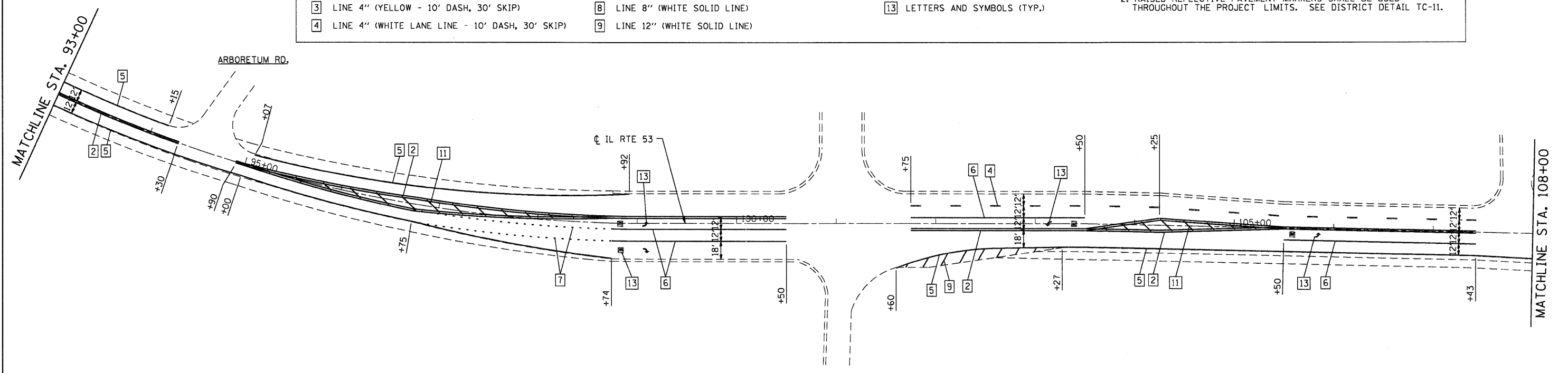

COMPANY NAME: HRGreen.com
 PROJECT CONTACT: #PROJECT_CONTACT1
 CLIENT: #CLIENT1
 DATE PLOTTED: 10/25/2011 6:22:56 PM
 FILE NAME: 86100196.06-pm-04.dgn
 PLOT DRIVER: pdfplot
 PLOT TABLE: standard-trans.tbl



USER NAME = SPernal	DESIGNED - J. ROITBURD	REVISED -
PLOT SCALE = 1" = 50'	DRAWN - R. BEST	REVISED -
PLOT DATE = 10/25/2011	CHECKED - T. HAMILTON	REVISED -
	DATE - 10/25/11	REVISED -

**STATE OF ILLINOIS
 DEPARTMENT OF TRANSPORTATION**

PAVEMENT MARKING PLAN			
ILLINOIS ROUTE 53 (WARRENVILLE RD. TO IL RTE. 38)			
SCALE: 1" = 50'	SHEET NO. 4 OF 7 SHEETS	STA. 93+00	TO STA. 123+00

F.A.P. RTE.	SECTION	COUNTY	TOTAL SHEETS	SHEET NO.
870	534X-RS-5	DUPAGE	35	16
FED. ROAD DIST. NO.			CONTRACT NO. 60N43	
ILLINOIS FED. AID PROJECT				

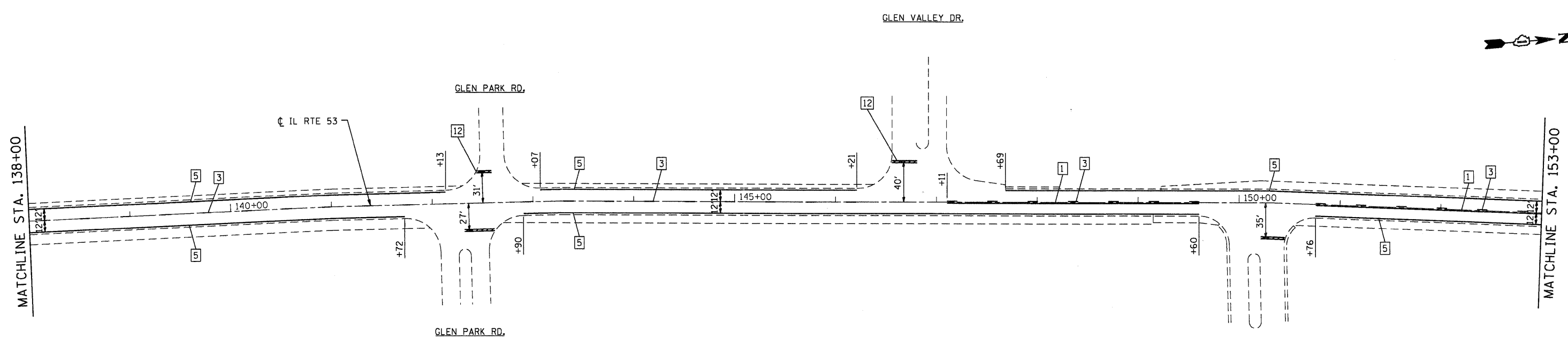
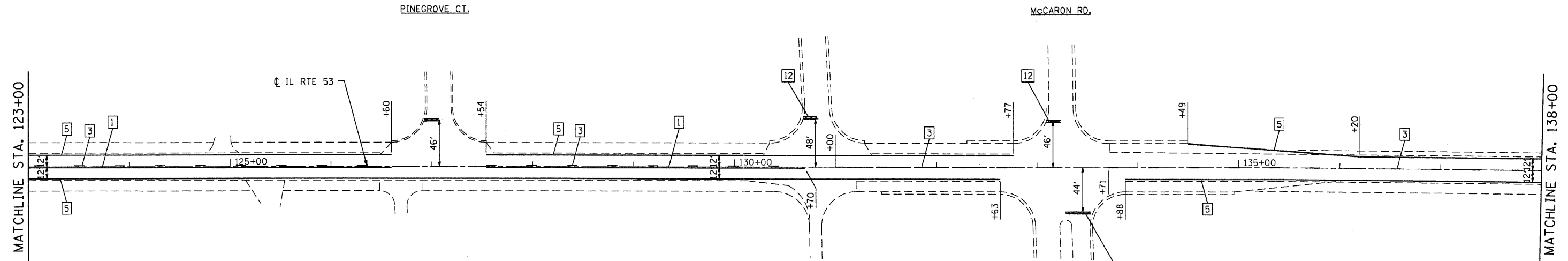

LEGEND			
1	LINE 4" (YELLOW SOLID LINE)	5	LINE 4" (WHITE SOLID LINE)
2	LINE 4" (DOUBLE YELLOW SOLID LINES)	6	LINE 6" (WHITE SOLID LINE)
3	LINE 4" (YELLOW - 10' DASH, 30' SKIP)	7	LINE 6" (WHITE LANE LINE - 2' DASH, 6' SKIP)
4	LINE 4" (WHITE LANE LINE - 10' DASH, 30' SKIP)	8	LINE 8" (WHITE SOLID LINE)
		9	LINE 12" (WHITE SOLID LINE)
		10	LINE 12" (WHITE DIAGONAL LINE)
		11	LINE 12" (YELLOW DIAGONAL LINE)
		12	LINE 24" (WHITE SOLID LINE)
		13	LETTERS AND SYMBOLS (TYP.)

NOTES:

- ALL PAVEMENT MARKINGS SHALL BE THERMOPLASTIC UNLESS OTHERWISE SPECIFIED.
- RAISED REFLECTIVE PAVEMENT MARKERS SHALL BE USED THROUGHOUT THE PROJECT LIMITS. SEE DISTRICT DETAIL TC-11.

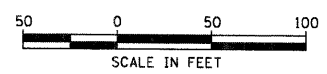

COMPANY NAME: HRGreen.com
 PROJECT CONTACT: #PROJECT CONTACT
 CLIENT: #CLIENT
 DATE PLOTTED: 10/25/2011 6:22:58 PM
 FILE NAME: 86100196_06-pm-05.dgn
 PLOT DRIVER: pdfplot
 PEN TABLE: standard-trans.tbl



USER NAME = SParnal	DESIGNED - J. ROITBURD	REVISED -
	DRAWN - R. BEST	REVISED -
PLOT SCALE = 1" = 50'	CHECKED - T. HAMILTON	REVISED -
PLOT DATE = 10/25/2011	DATE - 10/25/11	REVISED -

**STATE OF ILLINOIS
DEPARTMENT OF TRANSPORTATION**

**PAVEMENT MARKING PLAN
ILLINOIS ROUTE 53 (WARRENVILLE RD. TO IL RTE. 38)**

SCALE: 1" = 50' SHEET NO. 5 OF 7 SHEETS STA. 123+00 TO STA. 153+00

F.A.P. RTE.	SECTION	COUNTY	TOTAL SHEETS	SHEET NO.
870	534X-RS-5	DUPAGE	35	17
FED. ROAD DIST. NO.			ILLINOIS FED. AID PROJECT	
			CONTRACT NO. 60N43	

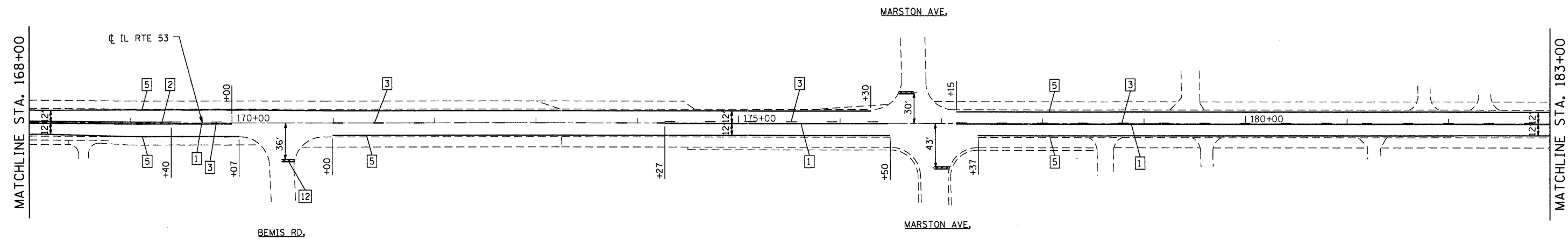
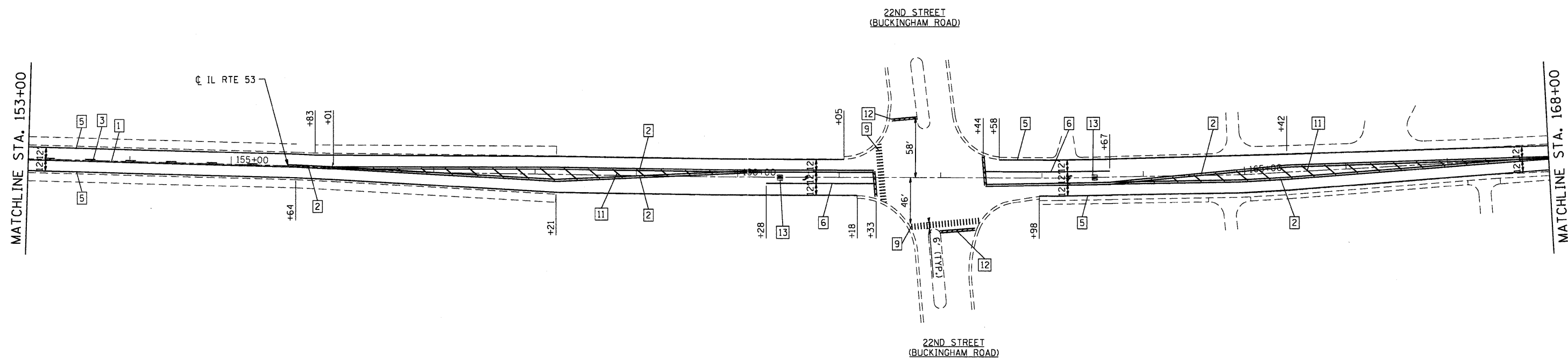

LEGEND

- | | | |
|--|--|------------------------------------|
| 1 LINE 4" (YELLOW SOLID LINE) | 5 LINE 4" (WHITE SOLID LINE) | 10 LINE 12" (WHITE DIAGONAL LINE) |
| 2 LINE 4" (DOUBLE YELLOW SOLID LINES) | 6 LINE 6" (WHITE SOLID LINE) | 11 LINE 12" (YELLOW DIAGONAL LINE) |
| 3 LINE 4" (YELLOW - 10' DASH, 30' SKIP) | 7 LINE 6" (WHITE LANE LINE - 2' DASH, 6' SKIP) | 12 LINE 24" (WHITE SOLID LINE) |
| 4 LINE 4" (WHITE LANE LINE - 10' DASH, 30' SKIP) | 8 LINE 8" (WHITE SOLID LINE) | 13 LETTERS AND SYMBOLS (TYP.) |
| | 9 LINE 12" (WHITE SOLID LINE) | |

NOTES:

- ALL PAVEMENT MARKINGS SHALL BE THERMOPLASTIC UNLESS OTHERWISE SPECIFIED.
- RAISED REFLECTIVE PAVEMENT MARKERS SHALL BE USED THROUGHOUT THE PROJECT LIMITS. SEE DISTRICT DETAIL TC-11.

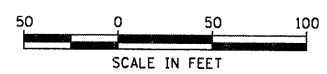

COMPANY NAME: HRGreen.com
 PROJECT CONTACT: SParnell
 CLIENT: HRGreen.com
 DATE PLOTTED: 10/25/2011 6:23:00 PM
 FILE NAME: 86100196.06-pm-06.dgn
 PLOT DRIVER: pcf.plt
 PEN TABLE: standard-trans.tbl



USER NAME = SParnell	DESIGNED - J. ROITBURD	REVISED -
PLOT SCALE = 1" = 50'	DRAWN - R. BEST	REVISED -
PLOT DATE = 10/25/2011	CHECKED - T. HAMILTON	REVISED -
	DATE - 10/25/11	REVISED -

**STATE OF ILLINOIS
DEPARTMENT OF TRANSPORTATION**

**PAVEMENT MARKING PLAN
ILLINOIS ROUTE 53 (WARRENVILLE RD. TO IL RTE. 38)**

SCALE: 1" = 50' SHEET NO. 6 OF 7 SHEETS STA. 153+00 TO STA. 183+00

F.A.P. RTE. 870	SECTION 534X-RS-5	COUNTY DUPAGE	TOTAL SHEETS 35	SHEET NO. 18
FED. ROAD DIST. NO. ILLINOIS FED. AID PROJECT			CONTRACT NO. 60N43	

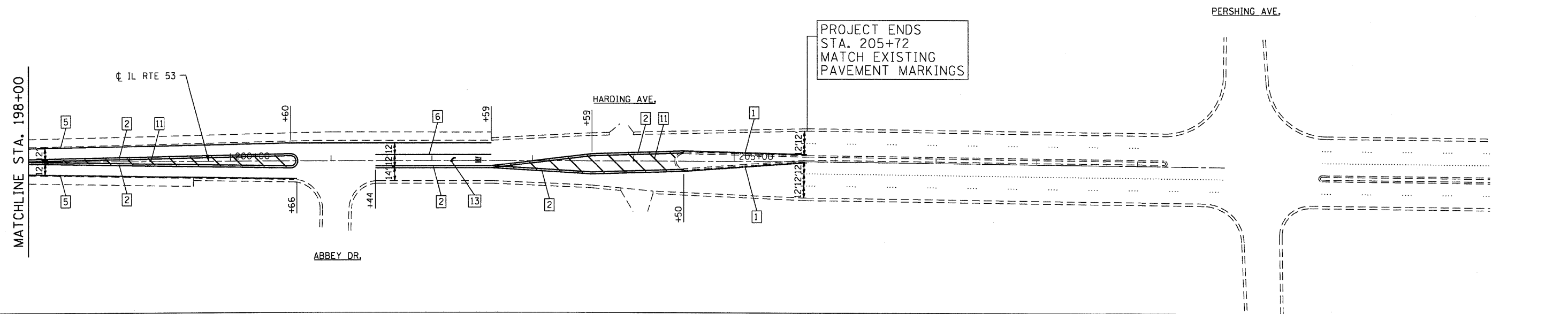
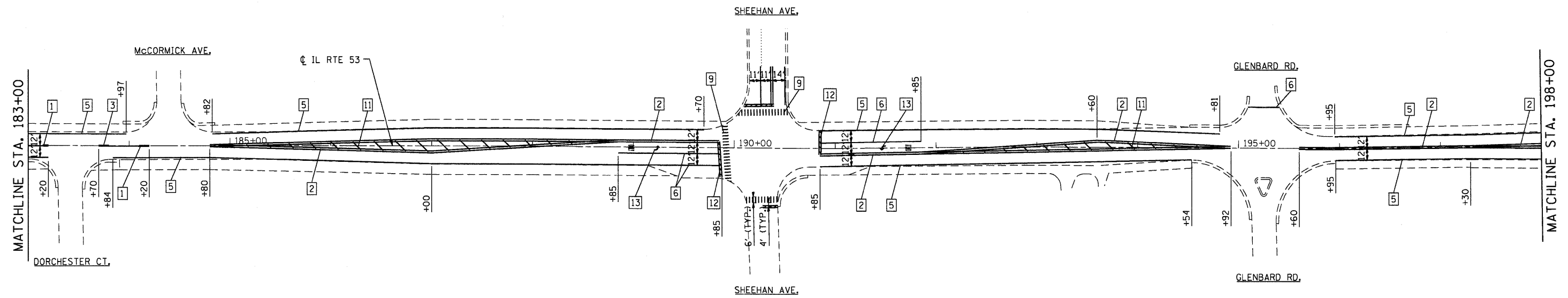

LEGEND

- | | | |
|--|--|------------------------------------|
| 1 LINE 4" (YELLOW SOLID LINE) | 5 LINE 4" (WHITE SOLID LINE) | 10 LINE 12" (WHITE DIAGONAL LINE) |
| 2 LINE 4" (DOUBLE YELLOW SOLID LINES) | 6 LINE 6" (WHITE SOLID LINE) | 11 LINE 12" (YELLOW DIAGONAL LINE) |
| 3 LINE 4" (YELLOW - 10' DASH, 30' SKIP) | 7 LINE 6" (WHITE LANE LINE - 2' DASH, 6' SKIP) | 12 LINE 24" (WHITE SOLID LINE) |
| 4 LINE 4" (WHITE LANE LINE - 10' DASH, 30' SKIP) | 8 LINE 8" (WHITE SOLID LINE) | 13 LETTERS AND SYMBOLS (TYP.) |
| | 9 LINE 12" (WHITE SOLID LINE) | |

NOTES:

- ALL PAVEMENT MARKINGS SHALL BE THERMOPLASTIC UNLESS OTHERWISE SPECIFIED.
- RAISED REFLECTIVE PAVEMENT MARKERS SHALL BE USED THROUGHOUT THE PROJECT LIMITS. SEE DISTRICT DETAIL TC-11.

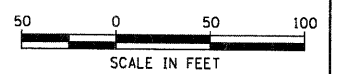

COMPANY NAME: HRGreen.com
 PROJECT CONTACT: SPernal
 CLIENT: HRGreen.com
 DATE PLOTTED: 10/25/2011 6:23:03 PM
 FILE NAME: 86100196-06-pm-07.dgn
 PLOT DRIVER: pldrvr
 PEN TABLE: standard.ctb



USER NAME = SPernal	DESIGNED - J. ROITBURD	REVISED -
	DRAWN - R. BEST	REVISED -
PLOT SCALE = 1" = 50'	CHECKED - T. HAMILTON	REVISED -
PLOT DATE = 10/25/2011	DATE - 10/25/11	REVISED -

**STATE OF ILLINOIS
DEPARTMENT OF TRANSPORTATION**

**PAVEMENT MARKING PLAN
ILLINOIS ROUTE 53 (WARRENVILLE RD. TO IL RTE. 38)**

SCALE: 1" = 50' SHEET NO. 7 OF 7 SHEETS STA. 183+00 TO STA. END

F.A.P. RTE. 870	SECTION 534X-RS-5	COUNTY DUPAGE	TOTAL SHEETS 35	SHEET NO. 19
FED. ROAD DIST. NO. ILLINOIS FED. AID PROJECT			CONTRACT NO. 60N43	

WORK SHALL MEET THE REQUIREMENTS OF THE SPECIAL PROVISION, "TRAFFIC SIGNAL SIGNAL SPECIFICATIONS FOR DETECTOR LOOP REPLACEMENT AND/OR INSTALLATION ON ROADWAY GRINDING, RESURFACING AND PATCHING OPERATIONS". SPECIAL ATTENTION MUST BE MADE TO THE SECTIONS "INSPECTION OF CONSTRUCTION" AND "DETECTOR LOOP REPLACEMENT" FOR INSTALLATION AND INSPECTION REQUIREMENTS. LOOP REPLACEMENT WORK THAT DOES NOT MEET THE CONTRACT REQUIREMENTS SHALL NOT BE PAID. WORK NECESSARY TO COMPLETE THE LOOP REPLACEMENT WORK MAY BE ASSIGNED BY THE ENGINEER TO IDOT'S ELECTRICAL MAINTENANCE CONTRACTOR (EMC); ALL RELATED COSTS WILL BE THE RESPONSIBILITY OF THE CONTRACTOR.

TRAFFIC SIGNAL LEGEND

	PROPOSED	EXISTING
SIGNAL HEAD WITH BACKPLATE		
SIGNAL HEAD		
GALVANIZED STEEL CONDUIT IN TRENCH OR PUSHED		
DETECTOR LOOP		
VEHICLE DETECTOR, NON COMPENSATED MAGNETIC TYPE		
RACEWAY FOR MAGNETIC DETECTOR, TYPE I OR TYPE II		

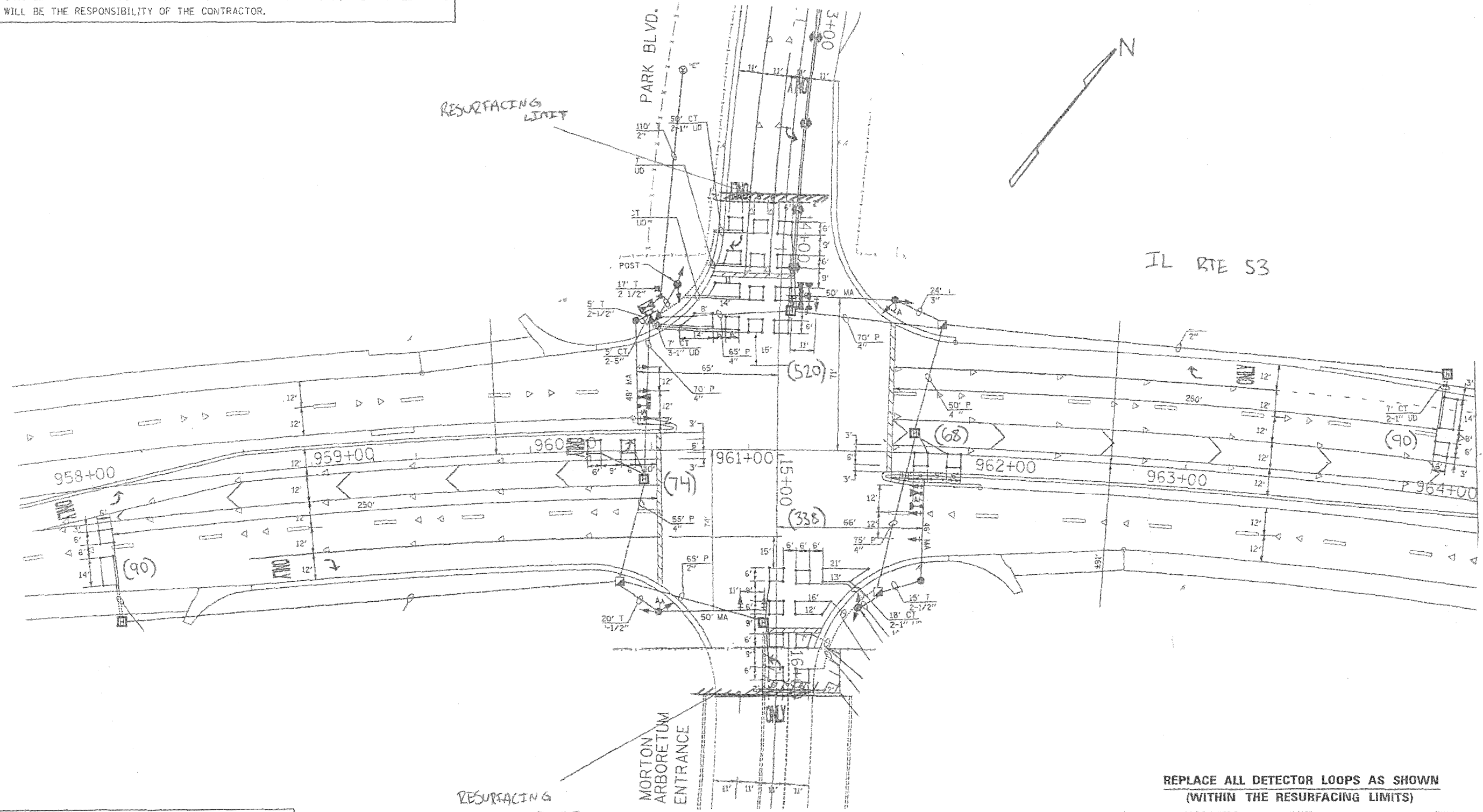

THIS PLAN IS FOR THE SOLE PURPOSE OF DETECTOR LOOP REPLACEMENTS ONLY

REPLACE ALL DETECTOR LOOPS AS SHOWN (WITHIN THE RESURFACING LIMITS)

CODE	QUANTITY	UNIT	ITEM
88600600	1180	FOOT	DETECTOR LOOP REPLACEMENT

COMPANY NAME: HRGreen.com
 PROJECT CONTACT: S.Pernal
 CLIENT: HRGreen
 DATE PLOTTED: 10/24/2011 2:32:55 PM
 FILE NAME: 86100196-06-stg-01.dgn
 PLOT DRIVER: pdt.plt
 PEN TABLE: standard-trans.tbl



USER NAME = S.Pernal	DESIGNED -	REVISED -
PLOT SCALE = N.T.S.	DRAWN -	REVISED -
PLOT DATE = 10/24/2011	CHECKED -	REVISED -
	DATE = 10/24/11	REVISED -

STATE OF ILLINOIS
DEPARTMENT OF TRANSPORTATION

DISTRICT 1 - DETECTOR LOOP REPLACEMENT
ILLINOIS ROUTE 53 @ PARK BLVD.

SCALE: N.T.S. SHEET NO. 1 OF 4 SHEETS STA. TO STA.

F.A.P. RTE.	SECTION	COUNTY	TOTAL SHEETS	SHEET NO.
870	534X-RS-5	DUPAGE	35	20
FED. ROAD DIST. NO. ILLINOIS FED. AID PROJECT			CONTRACT NO. 60N43	

WORK SHALL MEET THE REQUIREMENTS OF THE SPECIAL PROVISION, "TRAFFIC SIGNAL SPECIFICATIONS FOR DETECTOR LOOP REPLACEMENT AND/OR INSTALLATION ON ROADWAY GRINDING, RESURFACING AND PATCHING OPERATIONS". SPECIAL ATTENTION MUST BE MADE TO THE SECTIONS "INSPECTION OF CONSTRUCTION" AND "DETECTOR LOOP REPLACEMENT" FOR INSTALLATION AND INSPECTION REQUIREMENTS. LOOP REPLACEMENT WORK THAT DOES NOT MEET THE CONTRACT REQUIREMENTS SHALL NOT BE PAID. WORK NECESSARY TO COMPLETE THE LOOP REPLACEMENT WORK MAY BE ASSIGNED BY THE ENGINEER TO IDOT'S ELECTRICAL MAINTENANCE CONTRACTOR (EMC); ALL RELATED COSTS WILL BE THE RESPONSIBILITY OF THE CONTRACTOR.

TRAFFIC SIGNAL LEGEND

	PROPOSED	EXISTING
SIGNAL HEAD WITH BACKPLATE		
SIGNAL HEAD		
GALVANIZED STEEL CONDUIT IN TRENCH OR PUSHED		
DETECTOR LOOP		
VEHICLE DETECTOR, NON COMPENSATED MAGNETIC TYPE		
RACEWAY FOR MAGNETIC DETECTOR, TYPE I OR TYPE II		

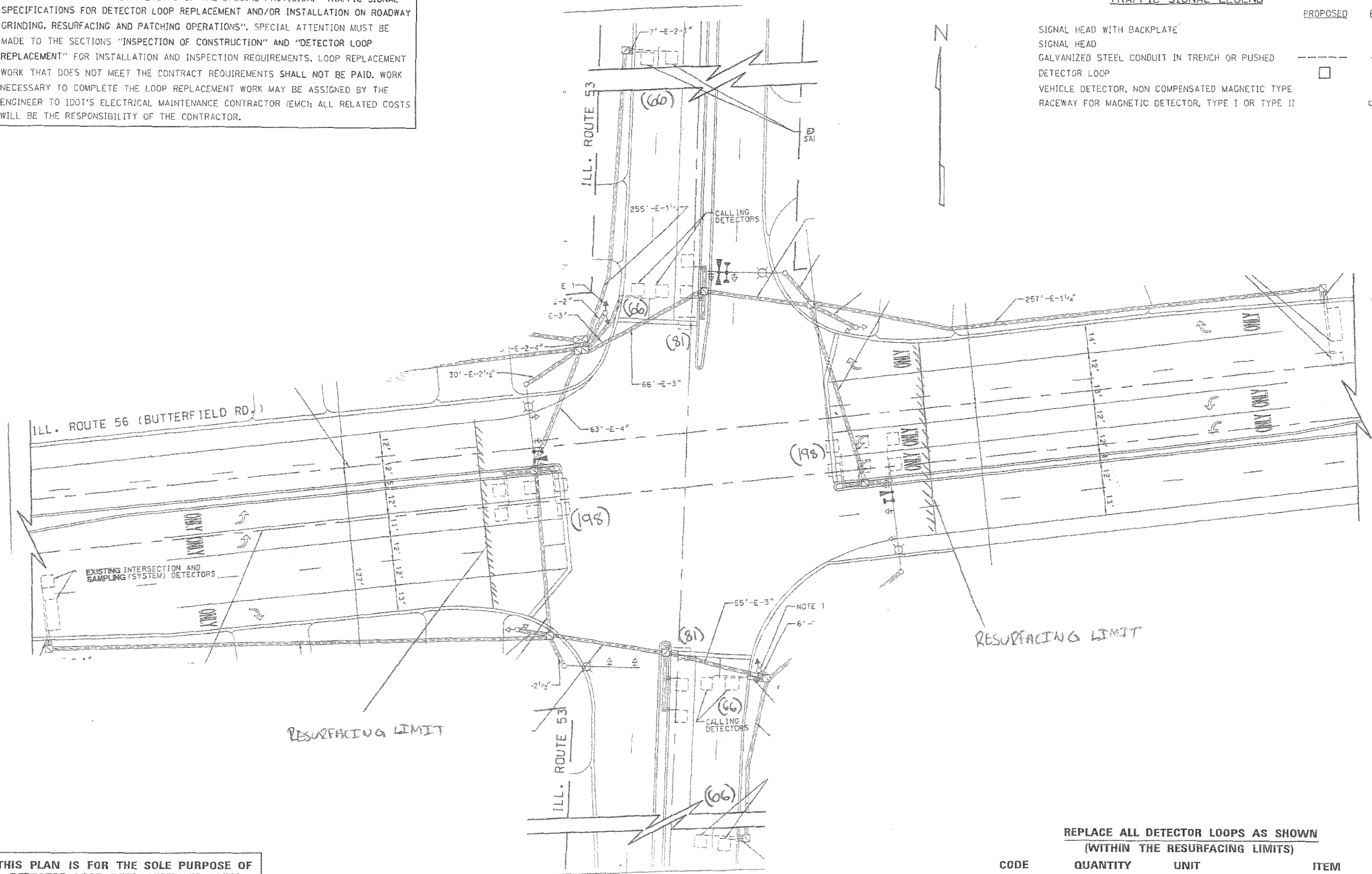

THIS PLAN IS FOR THE SOLE PURPOSE OF DETECTOR LOOP REPLACEMENTS ONLY

REPLACE ALL DETECTOR LOOPS AS SHOWN (WITHIN THE RESURFACING LIMITS)

CODE	QUANTITY	UNIT	ITEM
88600600	822	FOOT	DETECTOR LOOP, REPLACEMENT

COMPANY NAME: HRGreen.com
 PROJECT CONTACT: #PROJECT_CONTACT1
 CLIENT: #CLIENT1
 DATE PLOTTED: 10/24/2011 2:33:02 PM
 FILE NAME: 86100196.06-sig-02.dgn
 PLOT DRIVER: pdf.plt
 PEN TABLE: standard-trans.tbl



USER NAME = SPannel	DESIGNED -	REVISED -
PLOT SCALE = N.T.S.	CHECKED -	REVISED -
PLOT DATE = 10/24/2011	DATE - 10/24/11	REVISED -

**STATE OF ILLINOIS
DEPARTMENT OF TRANSPORTATION**

**DISTRICT 1 - DETECTOR LOOP REPLACEMENT
ILLINOIS ROUTE 53 @ ILLINOIS ROUTE 56**

SCALE: N.T.S. SHEET NO. 2 OF 4 SHEETS STA. TO STA.

F.A.P. RTE.	SECTION	COUNTY	TOTAL SHEETS	SHEET NO.
870	534X-RS-5	DUPAGE	35	21
FED. ROAD DIST. NO. ILLINOIS FED. AID PROJECT			CONTRACT NO. 60N43	

WORK SHALL MEET THE REQUIREMENTS OF THE SPECIAL PROVISION, "TRAFFIC SIGNAL SIGNAL SPECIFICATIONS FOR DETECTOR LOOP REPLACEMENT AND/OR INSTALLATION ON ROADWAY GRINDING, RESURFACING AND PATCHING OPERATIONS". SPECIAL ATTENTION MUST BE MADE TO THE SECTIONS "INSPECTION OF CONSTRUCTION" AND "DETECTOR LOOP REPLACEMENT" FOR INSTALLATION AND INSPECTION REQUIREMENTS. LOOP REPLACEMENT WORK THAT DOES NOT MEET THE CONTRACT REQUIREMENTS SHALL NOT BE PAID. WORK NECESSARY TO COMPLETE THE LOOP REPLACEMENT WORK MAY BE ASSIGNED BY THE ENGINEER TO IDOT'S ELECTRICAL MAINTENANCE CONTRACTOR (EMC); ALL RELATED COSTS WILL BE THE RESPONSIBILITY OF THE CONTRACTOR.

TRAFFIC SIGNAL LEGEND

	PROPOSED	EXISTING
SIGNAL HEAD WITH BACKPLATE	◁	▷
SIGNAL HEAD	◁	▷
GALVANIZED STEEL CONDUIT IN TRENCH OR PUSHED	---	---
DETECTOR LOOP	□	□
VEHICLE DETECTOR, NON COMPENSATED MAGNETIC TYPE	—	—
RACEWAY FOR MAGNETIC DETECTOR, TYPE I OR TYPE II	—	—



**THIS PLAN IS FOR THE SOLE PURPOSE OF
DETECTOR LOOP REPLACEMENTS ONLY**

**REPLACE ALL DETECTOR LOOPS AS SHOWN
(WITHIN THE RESURFACING LIMITS)**

CODE	QUANTITY	UNIT	ITEM
88600600	1014	FOOT	DETECTOR LOOP, REPLACEMENT

COMPANY NAME: HRGreen.com
PROJECT CONTACT: #PROJECT_CONTACT1
CLIENT: #CLIENT1
DATE PLOTTED: 10/24/2011 2:33:06 PM
FILE NAME: 86100196.06-rlg-01.dgn
PLOT DRIVER: pdf.plt
PEN TABLE: standard-trans.tbl



USER NAME = SPernal	DESIGNED -	REVISED -
PLOT SCALE = N.T.S.	DRAWN -	REVISED -
PLOT DATE = 10/24/2011	CHECKED -	REVISED -
	DATE - 10/24/11	REVISED -

**STATE OF ILLINOIS
DEPARTMENT OF TRANSPORTATION**

**DISTRICT 1 - DETECTOR LOOP REPLACEMENT
ILLINOIS ROUTE 53 @ 22ND ST.**

SCALE: N.T.S. SHEET NO. 3 OF 4 SHEETS STA. TO STA.

F.A.P. RTE. 870	SECTION 534X-RS-5	COUNTY DUPAGE	TOTAL SHEETS 35	SHEET NO. 22
FED. ROAD DIST. NO. ILLINOIS FED. AID PROJECT			CONTRACT NO. 60N43	

WORK SHALL MEET THE REQUIREMENTS OF THE SPECIAL PROVISION, "TRAFFIC SIGNAL SPECIFICATIONS FOR DETECTOR LOOP REPLACEMENT AND/OR INSTALLATION ON ROADWAY GRINDING, RESURFACING AND PATCHING OPERATIONS". SPECIAL ATTENTION MUST BE MADE TO THE SECTIONS "INSPECTION OF CONSTRUCTION" AND "DETECTOR LOOP REPLACEMENT" FOR INSTALLATION AND INSPECTION REQUIREMENTS. LOOP REPLACEMENT WORK THAT DOES NOT MEET THE CONTRACT REQUIREMENTS SHALL NOT BE PAID. WORK NECESSARY TO COMPLETE THE LOOP REPLACEMENT WORK MAY BE ASSIGNED BY THE ENGINEER TO IDOT'S ELECTRICAL MAINTENANCE CONTRACTOR (EMC); ALL RELATED COSTS WILL BE THE RESPONSIBILITY OF THE CONTRACTOR.

TRAFFIC SIGNAL LEGEND

	PROPOSED	EXISTING
SIGNAL HEAD WITH BACKPLATE	↔	↔
SIGNAL HEAD	↔	↔
GALVANIZED STEEL CONDUIT IN TRENCH OR PUSHED	—	—
DETECTOR LOOP	□	□
VEHICLE DETECTOR, NON COMPENSATED MAGNETIC TYPE	—	—
RACEWAY FOR MAGNETIC DETECTOR, TYPE I OR TYPE II	—	—

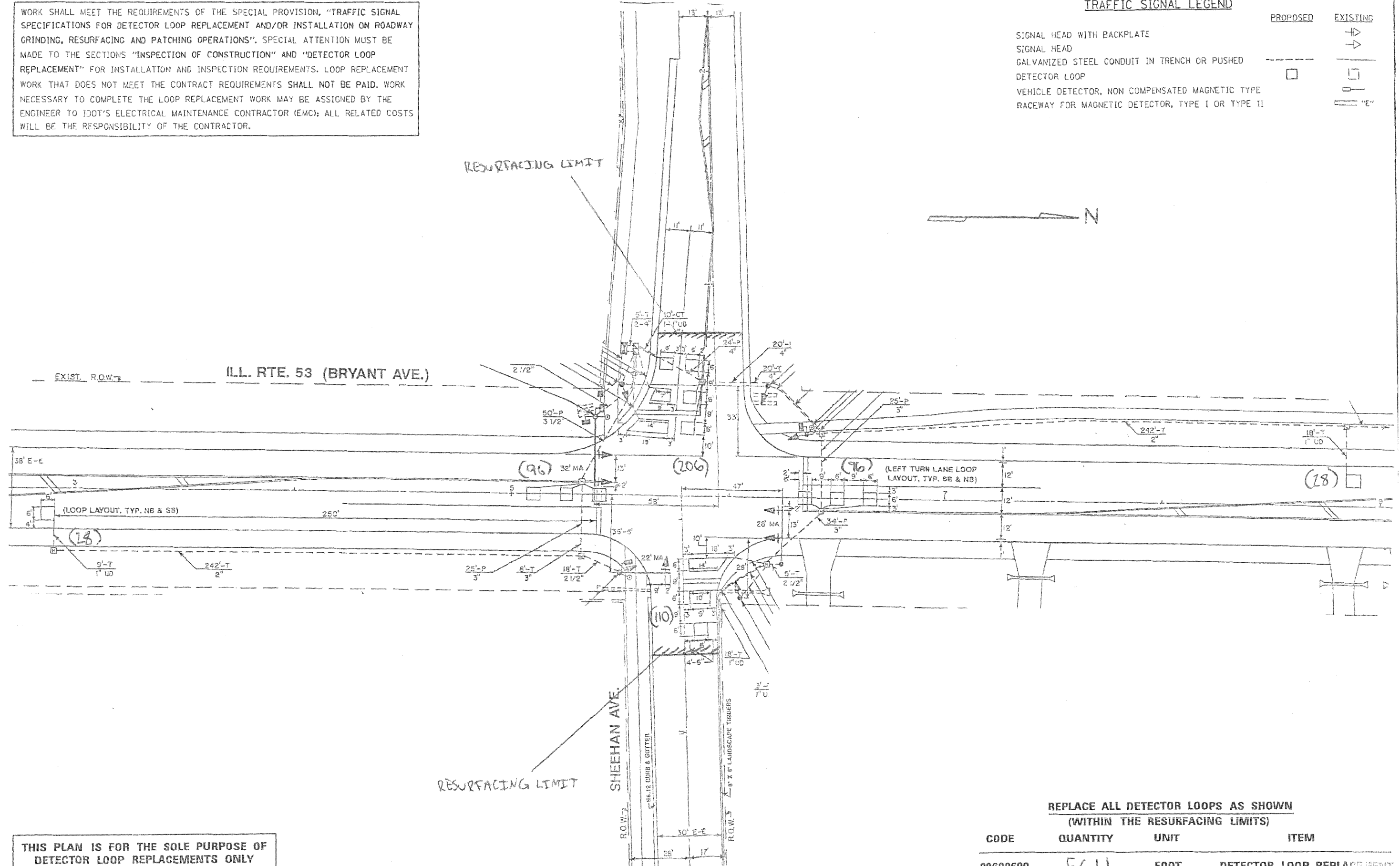

**THIS PLAN IS FOR THE SOLE PURPOSE OF
DETECTOR LOOP REPLACEMENTS ONLY**

**REPLACE ALL DETECTOR LOOPS AS SHOWN
(WITHIN THE RESURFACING LIMITS)**

CODE	QUANTITY	UNIT	ITEM
88600600	564	FOOT	DETECTOR LOOP, REPLACEMENT

COMPANY NAME: HRGreen.com
 PROJECT CONTACT: #PROJECT_CONTACT1
 CLIENT: #CLIENT1
 DATE PLOTTED: 10/24/2011 2:33:24 PM
 FILE NAME: 86000196.06-sig-04.dgn
 PLOT DRIVER: pdfplot
 PEN TABLE: standard-trans.tbl



USER NAME = SParnell	DESIGNED -	REVISED -
PLOT SCALE = N.T.S.	DRAWN -	REVISED -
PLOT DATE = 10/24/2011	CHECKED -	REVISED -
	DATE - 10/24/11	REVISED -

**STATE OF ILLINOIS
DEPARTMENT OF TRANSPORTATION**

**DISTRICT 1 - DETECTOR LOOP REPLACEMENT
ILLINOIS ROUTE 53 @ SHEEHAN AVE.**

SCALE: N.T.S. SHEET NO. 4 OF 4 SHEETS STA. TO STA. CONTRACT NO. 60N43

F.A.P. RTE.	SECTION	COUNTY	TOTAL SHEETS	SHEET NO.
870	534X-RS-5	DUPAGE	35	23

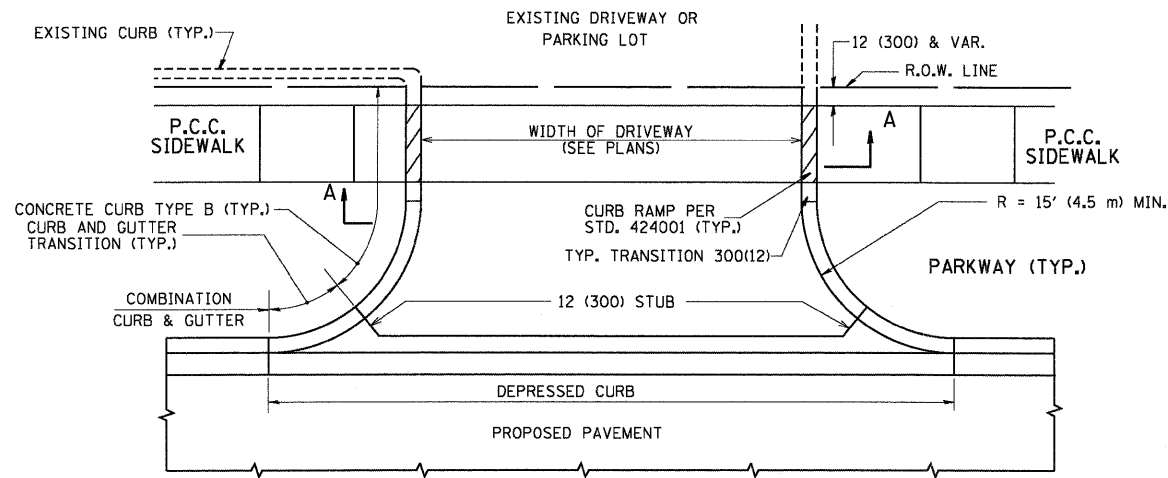

WITH CONCRETE CURB, TYPE B

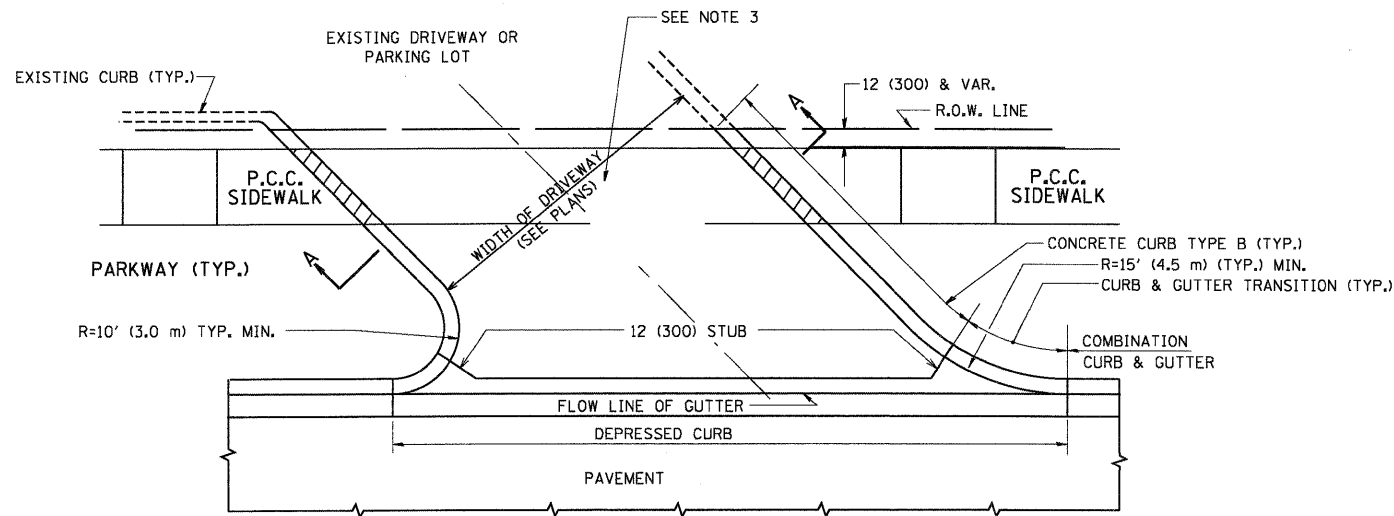

WITH CONCRETE CURB, TYPE B

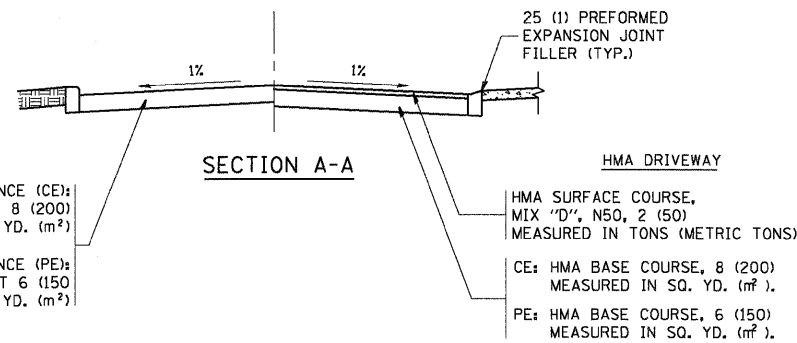

SECTION A-A

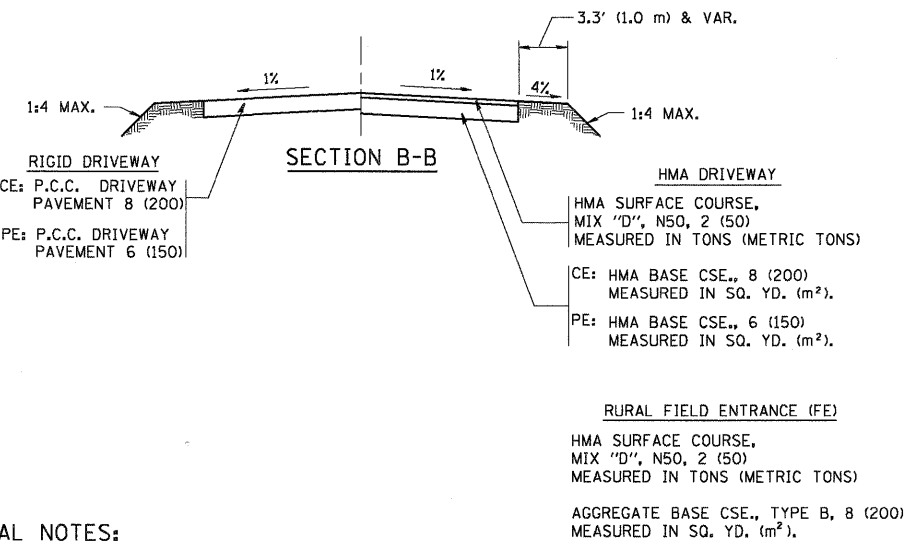
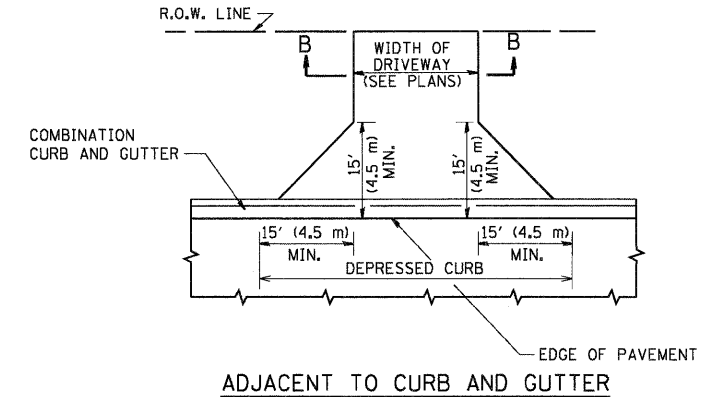
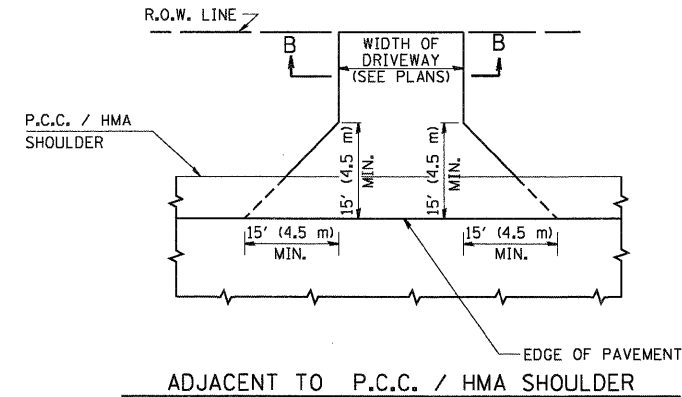

GENERAL NOTES:

DRIVEWAY SLOPES, LOCATIONS, & GEOMETRIC LAYOUT SHALL BE IN ACCORDANCE WITH THE LATEST EDITION OF THE "HANDBOOK FOR POLICY ON PERMITS FOR ACCESS DRIVEWAYS TO STATE HIGHWAYS". FOR FURTHER LAYOUT REQUIREMENTS, REFER TO ILLUSTRATIONS IN THE PERMIT HANDBOOK. DRIVEWAYS SHALL BE REPLACED IN KIND, UNLESS OTHERWISE NOTED ON THE PLANS.

COMMERCIAL DRIVEWAYS SHALL BE CONSTRUCTED WITH CONCRETE CURB, TYPE B RETURNS EXCEPT WHEN THE SIDEWALK EDGE IS 4 FEET (1.2 METERS) OR LESS FROM THE BACK OF CURB, CONSTRUCT A FLARE DRIVEWAY WITHOUT CURB.

THE RESIDENT ENGINEER SHALL CONTACT THE TRAFFIC PERMIT OFFICE AT 847/ 705-4131 FOR ANY QUESTIONS ON DRIVEWAYS SHOWN IN THE PLANS; SPECIFICALLY IN REFERENCE TO ADDITIONAL AND/OR RELOCATION/REMOVAL OF A DRIVEWAY.

COMBINATION CONCRETE CURB & GUTTER SHALL BE MEASURED STRAIGHT ACROSS THE DRIVEWAY. NO ADDITIONAL COMPENSATION WILL BE ALLOWED FOR THE CURB & GUTTER TRANSITION.

1 (25) PREFORMED EXPANSION JOINT FILLER WILL NOT BE PAID SEPARATELY, BUT SHALL BE CONSIDERED INCLUDED IN THE COST OF THE P.C.C. DRIVEWAY PAVEMENT OR P.C.C. SIDEWALK.

WHEN THE P.C.C. SIDEWALK EXTENDS THROUGH THE DRIVEWAY, THE THICKNESS OF THE SIDEWALK IN THE DRIVEWAY AREA SHALL BE THE SAME AS THE DRIVEWAY THICKNESS. SIDEWALK WILL BE PAID FOR AS P.C.C. SIDEWALK OF THE THICKNESS SPECIFIED. SIDEWALK CROSS SLOPE THRU DRIVEWAY AREA TO BE A MAXIMUM OF 1:50.

COMPANY NAME: HRGreen.com
PROJECT CONTACT: #PROJECT CONTACT
CLIENT: #CLIENT
DATE PLOTTED: 10/18/2011 9:44 AM
FILE NAME: B0100196-06-06-01.dgn
PLOT DRIVER: PdfPrinter-11f.pdf
PEN TABLE: s:\order-trans.tbl



USER NAME = lsgue	DESIGNED - R. SHAH	REVISED - P. LoFLUER 04-15-03
PLOT SCALE = 50.0000' / 1"	DRAWN -	REVISED - R. BORO 01-01-07
PLOT DATE = 9/5/2011	CHECKED -	REVISED - R. BORO 06-11-08
	DATE - 11-04-95	REVISED - R. BORO 09-06-11

STATE OF ILLINOIS
DEPARTMENT OF TRANSPORTATION

DRIVEWAY DETAILS - DISTANCE BETWEEN R.O.W. AND FACE OF CURB & EDGE OF SHOULDER >= 15' (4.5 m)	
SCALE: NONE	SHEET NO. 1 OF 1 SHEETS STA. TO STA.

F.A. RTE.	SECTION	COUNTY	TOTAL SHEETS	SHEET NO.
	534X-RS-5	DUPAGE	35	24
BD0156-07 (BD-01)		CONTRACT NO.	60N43	
FED. ROAD DIST. NO. 1 ILLINOIS FED. AID PROJECT				

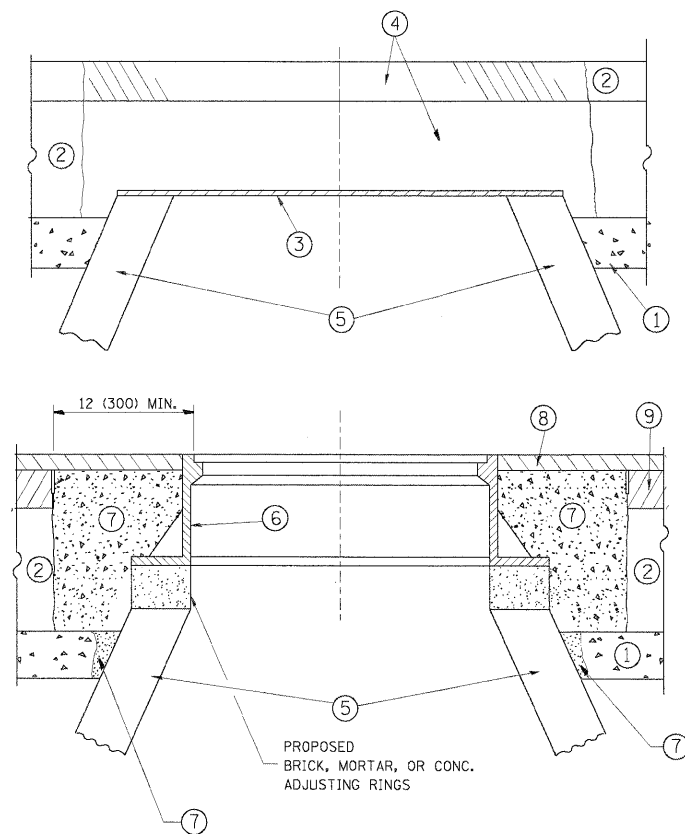

CONSTRUCTION PROCEDURES

STAGE 1 (BEFORE PAVEMENT MILLING)

- A) REMOVE A MINIMUM OF 12 (300) OF THE PAVEMENT FROM AROUND THE STRUCTURE.
- B) REMOVE THE EXISTING FRAME AND LID FROM THE STRUCTURE.
- C) COVER THE STRUCTURE OPENING WITH A 36 (900) DIAMETER METAL PLATE.
- D) BACKFILL WITH CRUSHED STONE AND A MINIMUM 1 1/2 (40) THICK HMA SURFACE MIX APPROVED BY THE ENGINEER.

STAGE 2 (AFTER PAVEMENT MILLING)

- A) REMOVE THE HMA SURFACE MIX AND CRUSHED STONE.
- B) INSTALL THE FRAME AND LID; ADJUST THE FRAME TO ITS FINAL SURFACE ELEVATION.
- C) THE SURROUNDING SPACE SHALL BE FILLED WITH CLASS PP-1* CONCRETE TO THE ELEVATION OF THE SURFACE OF THE EXISTING BASE COURSE OR THE BINDER COURSE.

* UNLESS OTHERWISE SPECIFIED IN THE PLANS.

THE PROCEDURE EXPLAINED ABOVE SHALL CONFORM TO THE APPLICABLE PORTIONS OF SECTIONS 353, 406, 602, AND 603 OF THE STANDARD SPECIFICATIONS.

LEGEND

- ① SUB-BASE GRANULAR MATERIAL
- ② EXISTING PAVEMENT
- ③ 36 (900) DIAMETER METAL PLATE
- ④ PROPOSED CRUSHED STONE AND HMA SURFACE MIX
- ⑤ EXISTING STRUCTURE
- ⑥ FRAME AND LID (SEE NOTES)
- ⑦ CLASS PP-1* CONCRETE
- ⑧ PROPOSED HMA SURFACE COURSE
- ⑨ PROPOSED HMA BINDER COURSE

LOCATION OF STRUCTURES:

THE CONTRACTOR WILL BE REQUIRED TO KEEP A RECORD OF THE LOCATIONS OF THE BURIED STRUCTURES ACCORDING TO THE STATION AND DISTANCE LEFT OR RIGHT OF THE CENTERLINE OF PAVEMENT. UPON COMPLETION OF THE WORK, THE CONTRACTOR WILL DELIVER THE RECORD TO THE ENGINEER.

BASIS OF PAYMENT: THIS WORK WILL BE PAID FOR AT THE CONTRACT UNIT PRICE PER EACH FOR "FRAMES AND LIDS TO BE ADJUSTED, SPECIAL" NEW FRAMES AND LIDS, WHEN SPECIFIED, WILL BE PAID FOR SEPARATELY.

NOTES:

EXISTING BROKEN FRAMES AND LIDS SHALL BE REMOVED AND DISPOSED OF BY THE CONTRACTOR AND SHALL BE REPLACED AS DIRECTED BY THE ENGINEER. REPLACEMENT FRAMES AND LIDS WILL BE PAID FOR IN ACCORDANCE WITH ARTICLE 109.04 OF THE STANDARD SPECIFICATIONS UNLESS A SEPARATE PAY ITEM HAS BEEN PROVIDED.

IF THE EXISTING LIDS ARE OPEN, THE FRAME WILL BE ADJUSTED TO THE ELEVATION OF THE MILLED PAVEMENT SURFACE PRIOR TO THE MILLING OPERATION. THE FRAME WILL NOT BE REMOVED AND COVERED BY THE METAL PLATE.

CITY OF CHICAGO CASTINGS ARE THE PROPERTY OF THE CITY AND THE CONTRACTOR SHALL NOTIFY THE CITY FOR REMOVAL AND DISPOSITION OF THE CASTINGS.

THE METAL PLATE USED TO COVER THE STRUCTURE SHALL REMAIN THE PROPERTY OF THE CONTRACTOR.

WHEN STRUCTURES ARE TO BE ADJUSTED OR RECONSTRUCTED, THE LOWERING AND RAISING OF THE FRAMES AND LIDS WILL NOT BE PAID FOR SEPARATELY BUT WILL BE INCLUDED IN THE COST OF THE CORRESPONDING PAY ITEM.

DETAILS FOR FRAMES AND LIDS ADJUSTMENT WITH MILLING

ALL DIMENSIONS ARE IN INCHES (MILLIMETERS) UNLESS OTHERWISE SHOWN

COMPANY NAME: #COMPANY_NAME/ HRGreen.com
 PROJECT CONTACT: #PROJECT_CONTACT/ HRGreen.com
 CLIENT: #CLIENT/ HRGreen.com
 DATE PLOTTED: 10/18/2011 5:10:21 PM
 FILE NAME: 86100196.06-def-02.dgn
 PLOT DRIVER: pdf_dwt-01-11ff.pdf
 PEN TABLE: standard-trans.tbl



USER NAME = lsh99	DESIGNED - R. SHAH	REVISED - A. ABBAS 03-21-97
	DRAWN -	REVISED - R. WIEDEMAN 05-14-04
PLOT SCALE = 49.9999 1/16 IN.	CHECKED -	REVISED - R. BORO 01-01-07
PLOT DATE = 3/18/2011	DATE - 10-25-94	REVISED - R. BORO 03-09-11

**STATE OF ILLINOIS
DEPARTMENT OF TRANSPORTATION**

DETAILS FOR FRAMES AND LIDS ADJUSTMENT WITH MILLING			
SCALE: NONE	SHEET NO. 1 OF 1 SHEETS	STA.	TO STA.

F.A. RTE.	SECTION	COUNTY	TOTAL SHEETS	SHEET NO.
	534X-RS-5	DUPAGE	35	25
BD600-03 (BD-8)			CONTRACT NO. 60N43	
FED. ROAD DIST. NO. 1 ILLINOIS FED. AID PROJECT				

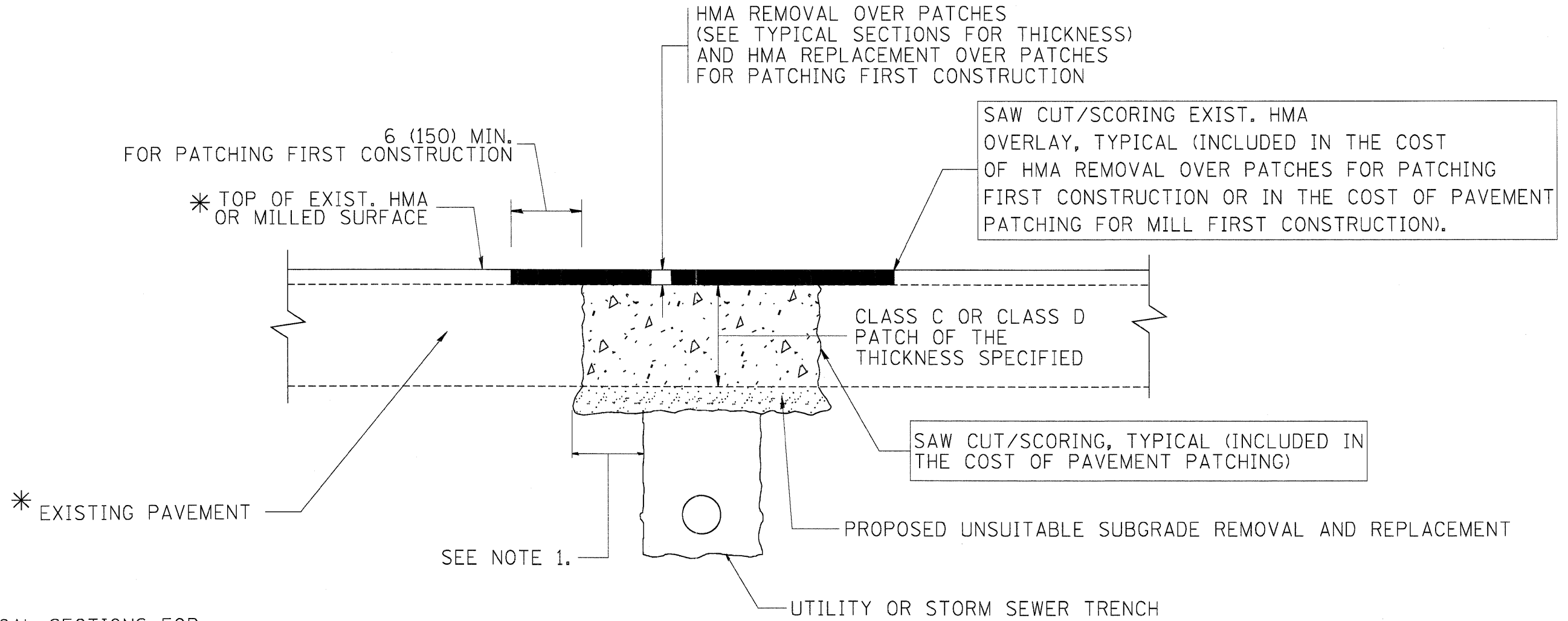

* SEE TYPICAL SECTIONS FOR THICKNESS AND MATERIALS

NOTES:

1. THE WIDTH OF THE FULL DEPTH PATCH OVER A TRENCH SHALL BE 12 (300) WIDER ON EACH SIDE OF THE TRENCH.
2. FOR METHOD OF MEASUREMENT AND BASIS OF PAYMENT, SEE RECURRING SPECIAL PROVISION "PATCHING WITH HOT-MIX ASPHALT OVERLAY REMOVAL".

SEQUENCE OF CONSTRUCTION (PATCHING FIRST)

1. REMOVE THE EXISTING HMA MATERIAL OVER THE AREA TO BE PATCHED.
2. REMOVE AND REPLACE WITH CLASS C OR D PATCH.
3. REPLACE HMA MATERIAL OVER THE AREA TO BE PATCHED.

SEQUENCE OF CONSTRUCTION (MILLING FIRST)

1. MILL HMA FIRST IF THERE IS AT LEAST 4 1/2 INCHES OR MORE OF HMA MATERIAL ON TOP OF THE EXISTING PAVEMENT OR IF THE PAVEMENT IS FULL DEPTH HMA. A MINIMUM OF 2 INCHES OF HMA MATERIAL SHALL BE IN PLACE AFTER MILLING.
2. REMOVE AND REPLACE WITH FULL DEPTH CLASS D PATCHES TO TOP OF MILLED SURFACE.

ALL DIMENSIONS ARE IN INCHES (MILLIMETERS) UNLESS OTHERWISE SHOWN.

COMPANY NAME: #/COMPANY NAME
 PROJECT CONTACT: #/PROJECT CONTACT
 CLIENT: #/CLIENT
 DATE PLOTTED: 10/18/2001 9:18:48 AM
 FILE NAME: 86100916.06-09-01.dgn
 PLOT DRIVER: pcf_dwt-11rfdwt
 PEN TABLE: standard-trans.tbl



USER NAME = beurd1	DESIGNED - R. SHAH	REVISED - A. ABBAS 04-27-98
	DRAWN -	REVISED - R. BORO 01-01-07
PLOT SCALE = 50.000' / IN.	CHECKED -	REVISED - R. BORO 09-04-07
PLOT DATE = 10/27/2008	DATE - 10-25-94	REVISED - K. ENG 10-27-08

**STATE OF ILLINOIS
 DEPARTMENT OF TRANSPORTATION**

PAVEMENT PATCHING FOR HMA SURFACED PAVEMENT		
SCALE: NONE	SHEET NO. 1 OF 1 SHEETS	STA. TO STA.

F.A. RTE.	SECTION	COUNTY	TOTAL SHEETS	SHEET NO.
	534X-RS-5	DUPAGE	35	26
BD400-04 (BD-22)		CONTRACT NO. 60N43		
FED. ROAD DIST. NO. 1 ILLINOIS FED. AID PROJECT				

VARIABLE - TO MEET EXISTING DIMENSIONS AND FIELD CONDITIONS (SEE NOTE ②)

PROP. CONC. CURB OR CURB AND GUTTER REPLACEMENT IN ACCORDANCE WITH STATE STANDARD 606001. (SEE NOTE ②)

SAW CUT FULL DEPTH - INCLUDED IN THE COST OF SIDEWALK, DRIVEWAY OR MEDIAN SURFACE REMOVAL PAY ITEM.

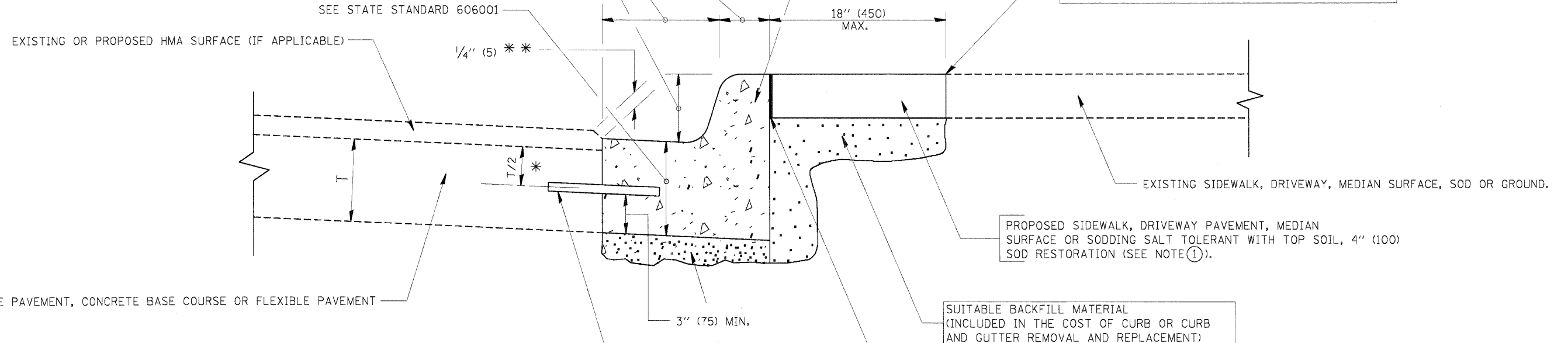

- * 3" (75) MINIMUM FROM TOP AND BOTTOM OF THE CONCRETE PAVEMENT OR BASE COURSE.
- * * IF THE FINAL SURFACE OF THE PAVEMENT IS CONCRETE, THE GUTTER IS TO BE FLUSH WITH THE PAVEMENT.

NOTE: ① SIDEWALK, DRIVEWAY PAVEMENT OR MEDIAN SURFACE SHALL BE SIMILAR TO THE MATERIAL BEING REMOVED AND WILL BE PAID FOR SEPARATELY.
SODDING, SALT TOLERANT AND TOP SOIL, FURNISH AND PLACE 4" WILL BE PAID FOR SEPARATELY,

- ② FERTILIZER FOR THE PLACEMENT OF THE SOD IS NOT REQUIRED
- ③ CURB OR CURB AND GUTTER REPLACEMENT SHALL MATCH THE SHAPE OF THE EXISTING CURB OR CURB AND GUTTER UNLESS OTHERWISE SPECIFIED.
- ④ FOR CURB OR CURB AND GUTTER REMOVAL AND REPLACEMENT ADJACENT TO FLEXIBLE PAVEMENT DELETE EPOXY COATED TIE BARS.
- ⑤ LONGITUDINAL BARS, IF ENCOUNTERED IN THE EXISTING CURB OR CURB AND GUTTER, ARE NOT TO BE REPLACED. CUTTING AND REMOVING LONGITUDINAL BARS SHALL BE INCLUDED IN THE COST OF CURB OR CURB AND GUTTER REMOVAL AND REPLACEMENT.
- ⑥ THE COST OF HMA SURFACE REMOVAL IN THE EXISTING GUTTER FLAG SHALL BE INCLUDED IN THE COST OF THE CURB AND GUTTER REMOVAL AND REPLACEMENT.
- ⑦ THE REMOVAL AND REPLACEMENT OF THE EXISTING CURB OR CURB AND GUTTER SHALL BE DONE IN ACCORDANCE WITH THE APPLICABLE PORTIONS OF SECTION 440 AND 606 OF THE STANDARD SPECIFICATIONS.
- ⑧ THE LOCATIONS OF REMOVAL AND REPLACEMENT OF EXISTING CURB OR CURB AND GUTTER SHALL BE DETERMINED BY THE RESIDENT ENGINEER AT THE TIME OF CONSTRUCTION.

SUITABLE BACKFILL MATERIAL (INCLUDED IN THE COST OF CURB OR CURB AND GUTTER REMOVAL AND REPLACEMENT)

PROPOSED 3/4" (20) PREFORMED EXPANSION JOINT AT CONCRETE SIDEWALKS, DRIVEWAYS, AND MEDIANS. (INCLUDED IN THE COST OF CURB OR CURB AND GUTTER REMOVAL AND REPLACEMENT.)

UNSUITABLE SUB-BASE MATERIAL TO BE REMOVED, IF DIRECTED BY THE ENGINEER, SHALL BE REPLACED WITH EITHER SUB-BASE GRANULAR MATERIAL, TYPE B OR ADDITIONAL THICKNESS OF CONCRETE.

REMOVAL AND REPLACEMENT 4" (100) OR LESS IS INCLUDED IN THE COST OF CURB OR CURB AND GUTTER REMOVAL AND REPLACEMENT.

REMOVAL AND REPLACEMENT IN EXCESS OF 4" (100) WILL BE PAID FOR IN ACCORDANCE WITH ARTICLE 109.04 OF THE STANDARD SPECIFICATIONS.

PROPOSED #6 (20) EPOXY COATED TIE BARS 24" (600) LONG AT 24" (600) CENTERS WILL NOT BE PAID FOR SEPARATELY. DELETE EPOXY COATED TIE BARS IF EXISTING TIE BARS ARE USUABLE AS DETERMINED BY THE ENGINEER. (SEE NOTE ③).

BASIS OF PAYMENT:

THIS WORK WILL BE PAID FOR AT THE CONTRACT UNIT PRICE PER FOOT (METER) FOR "CURB REMOVAL AND REPLACEMENT" OR "COMBINATION CONCRETE CURB AND GUTTER REMOVAL AND REPLACEMENT".

CURB OR CURB AND GUTTER REMOVAL AND REPLACEMENT

ALL DIMENSIONS ARE IN INCHES (MILLIMETERS) UNLESS OTHERWISE SHOWN.

COMPANY NAME: HRGreen
PROJECT CONTACT: HRGreen
CLIENT: HRGreen
DATE PLOTTED: 10/18/2011 5:13:37 PM
FILE NAME: 66100196.06-061-04.dgn
PLOT DRIVER: perf-dt-01-tiff.dlt
PEN TABLE: standard-trans.tbl



USER NAME = drivakoagn	DESIGNED - A. HOUSEH	REVISED - R. SHAH 10-03-96
	DRAWN -	REVISED - A. ABBAS 03-21-97
PLOT SCALE = 50.0000 / IN.	CHECKED -	REVISED - M. GOMEZ 01-22-01
PLOT DATE = 12/16/2009	DATE - 03-11-94	REVISED - R. BORO 12-15-09

STATE OF ILLINOIS
DEPARTMENT OF TRANSPORTATION

CURB OR CURB AND GUTTER
REMOVAL AND REPLACEMENT

SCALE: NONE SHEET NO. 1 OF 1 SHEETS STA. TO STA.

F.A. RTE.	SECTION	COUNTY	TOTAL SHEETS	SHEET NO.
	534X-RS-5	DUPAGE	35	27
BD600-06 (BD-24)		CONTRACT NO. 60N43		
FED. ROAD DIST. NO. 1 ILLINOIS FED. AID PROJECT				

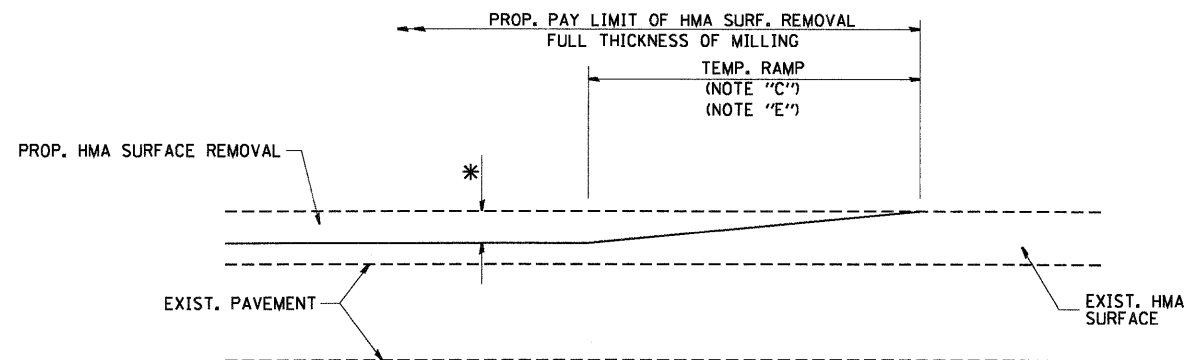

MILLED TEMPORARY RAMP
(FOR BUTT JOINT AND HMA TAPER SEE DETAIL BELOW)

OPTION 1

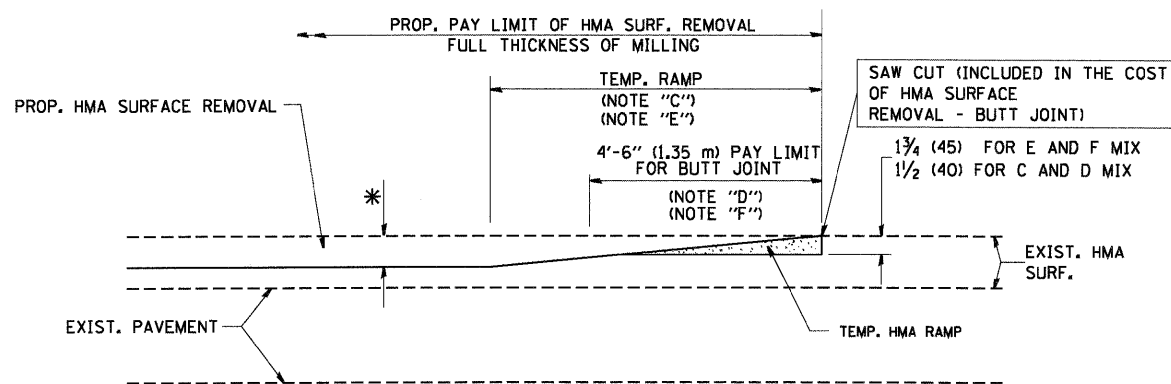

HMA CONSTRUCTED TEMPORARY RAMP
(FOR BUTT JOINT AND HMA TAPER SEE DETAIL BELOW)

OPTION 2
TYPICAL TEMPORARY RAMP

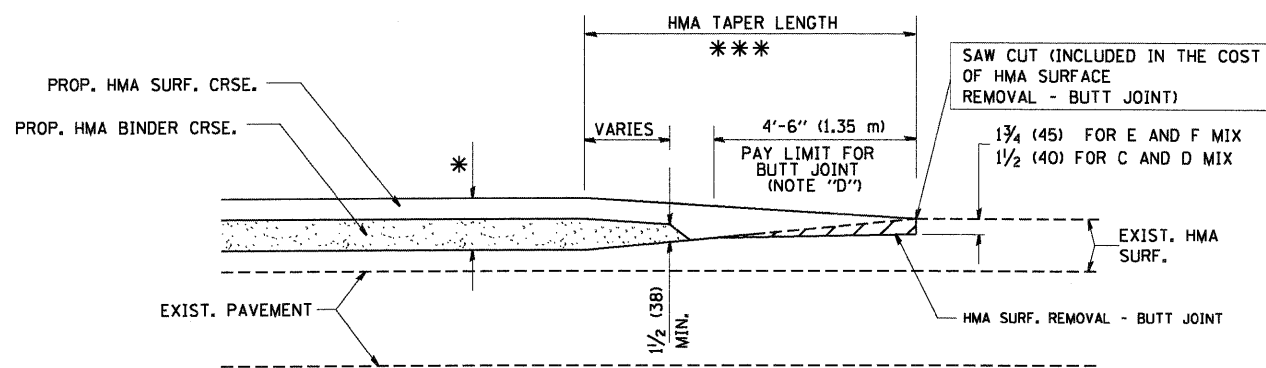

TYPICAL BUTT JOINT AND HMA TAPER
FOR MILLING AND RESURFACING

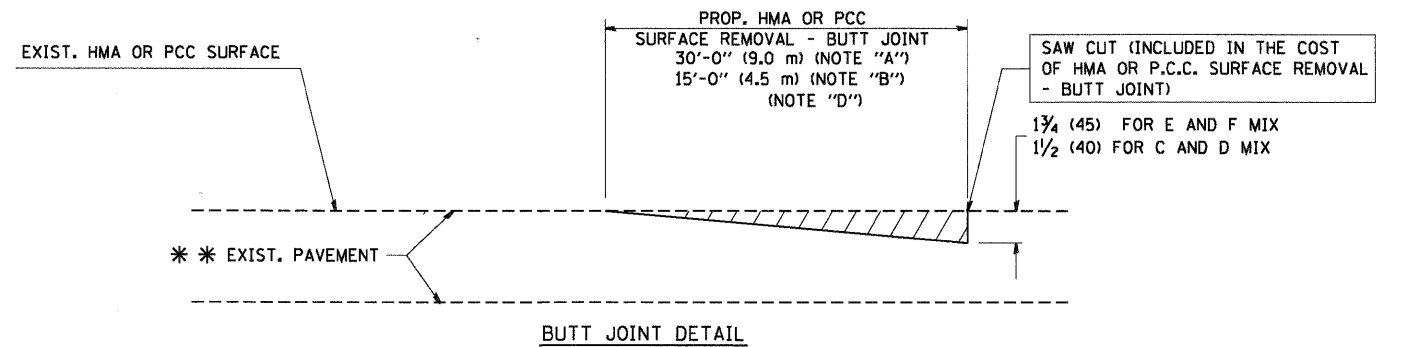

BUTT JOINT DETAIL

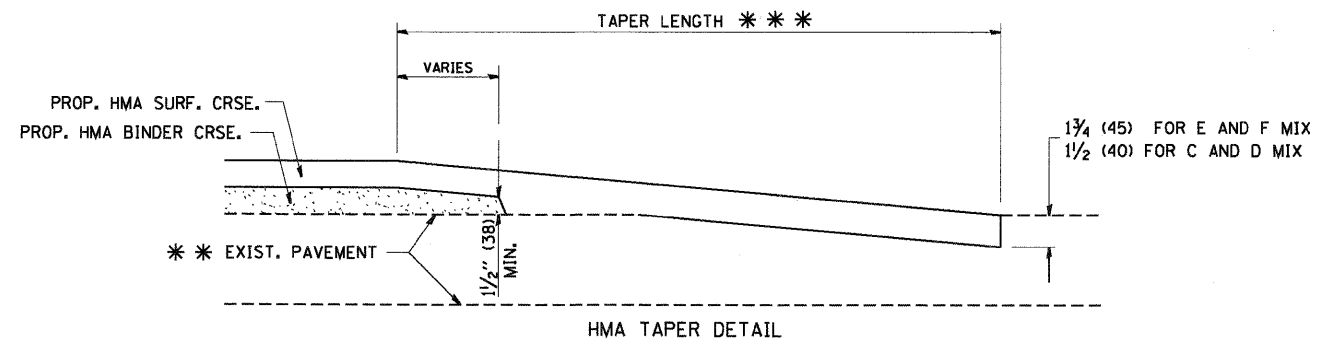

TYPICAL BUTT JOINT AND HMA TAPER
FOR RESURFACING ONLY

*** PC CONCRETE, HMA OR HMA RESURFACED PAVEMENT.

NOTES

- A: MAINLINE ROADWAYS AND MAJOR SIDE ROADS.
 - B: MINOR SIDE ROADS.
 - C: THE TEMP. RAMP SHALL BE CONSTRUCTED IMMEDIATELY UPON REMOVAL OF THE EXISTING HMA SURFACE.
 - D: THE BUTT JOINT SHALL BE CONSTRUCTED IMMEDIATELY PRIOR TO PLACING THE PROPOSED HMA COURSES.
 - E: TAPER THE TEMP. RAMP AT A RATE OF 3'-0" (900 mm) PER 1 INCH (25 mm) OF MILLING THICKNESS.
 - F: INSTALLATION AND REMOVAL OF THE 4'-6" (1.35 m) TEMP. RAMP IS INCLUDED IN COST OF HMA SURFACE REMOVAL - BUTT JOINT
 - G: SEE ARTICLE 406.08 AND 406.14 OF THE STANDARD SPECIFICATIONS FOR "HMA AND/OR PCC SURFACE REMOVAL, BUTT JOINT".
- * SEE TYPICAL SECTIONS FOR MILLING THICKNESS.
- *** 20'-0" (6.1 m) PER 1 (25) RESURFACING (NOTE "A")
10'-0" (3.0 m) PER 1 (25) RESURFACING (NOTE "B")

BASIS OF PAYMENT:

THE BUTT JOINT WILL BE PAID FOR AT THE CONTRACT UNIT PRICE PER SQUARE YARD (SQUARE METER) FOR "HOT-MIX ASPHALT SURFACE REMOVAL - BUTT JOINT" OR FOR "PORTLAND CEMENT CONCRETE SURFACE REMOVAL - BUTT JOINT".

ALL DIMENSIONS ARE IN INCHES (MILLIMETERS) UNLESS OTHERWISE SHOWN.

COMPANY NAME: HRGreen
PROJECT CONTACT: #PROJECT CONTACT
CLIENT: #CLIENT
DATE PLOTTED: 10/18/2011 9:48:52 AM
FILE NAME: 86100196-06-06-05.dgn
PLOT DRIVER: pdfcvt.plt
PEN TABLE: s:\standard-trans.tbl



USER NAME = geglentobt	DESIGNED - M. DE YONG	REVISED - R. SHAH 10-25-94
PLOT SCALE = 50.0000' / IN.	DRAWN - A. ABBAS 03-21-97	REVISED - M. GOMEZ 04-06-01
PLOT DATE = 1/4/2008	CHECKED -	REVISED - R. BORO 01-01-07
	DATE - 06-13-90	

STATE OF ILLINOIS
DEPARTMENT OF TRANSPORTATION

BUTT JOINT AND HMA TAPER DETAILS	
SCALE: NONE	SHEET NO. 1 OF 1 SHEETS
STA.	TO STA.

F.A. RTE.	SECTION	COUNTY	TOTAL SHEETS	SHEET NO.
	534X-RS-5		35	28
BD400-05 BD32		DUPAGE		CONTRACT NO. 60N43
FED. ROAD DIST. NO. 1 ILLINOIS FED. AID PROJECT				

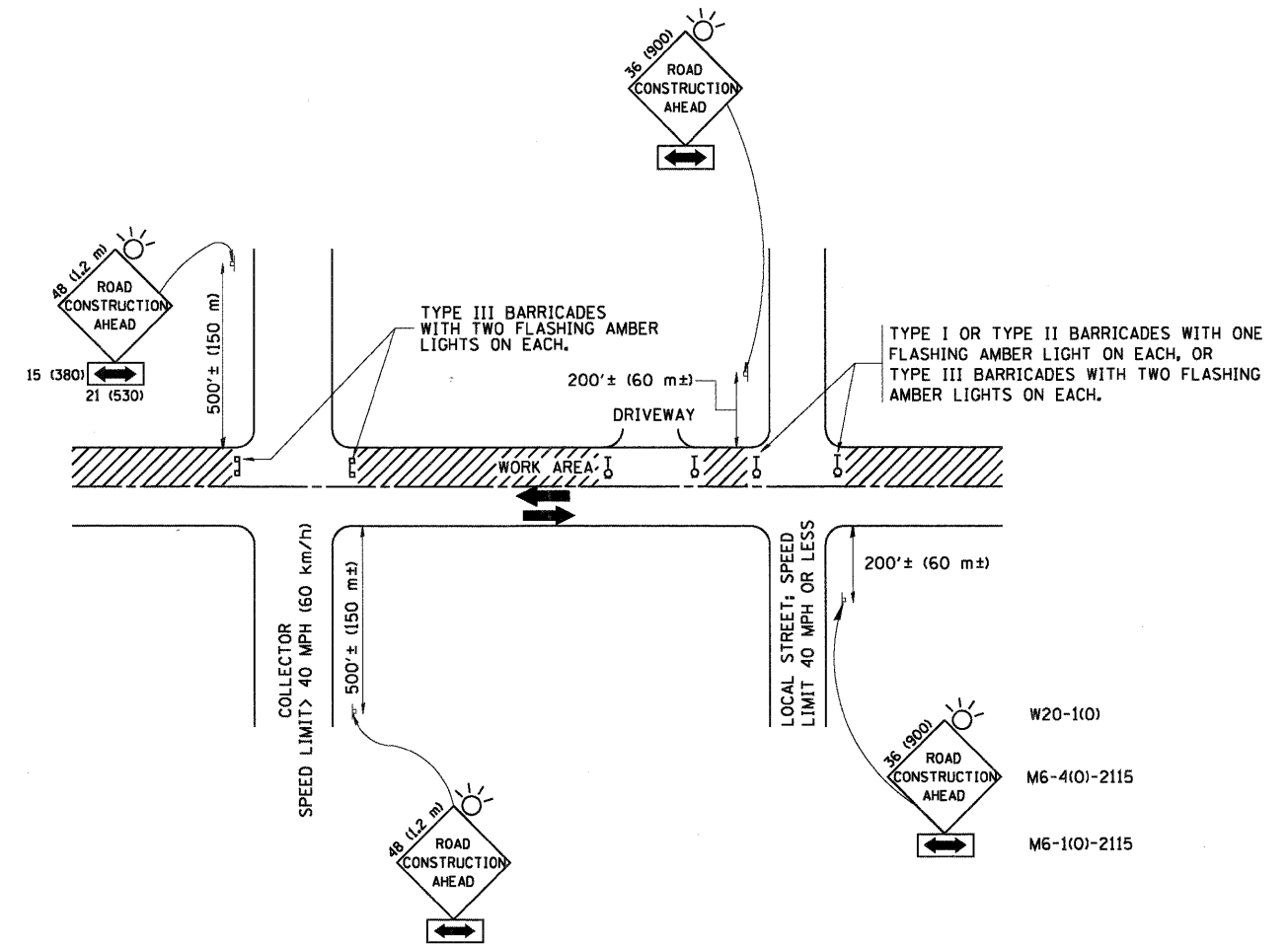

TRAFFIC CONTROL AND PROTECTION FOR SIDE ROADS, INTERSECTIONS, AND DRIVEWAYS

NOTES:

- A. FOR NO LANE RESTRICTION ON THE SIDE ROAD OR DRIVEWAYS
 1. SIDE ROAD WITH A SPEED LIMIT OF 40 MPH (60 km/h) OR LESS AS SHOWN ON THE DRAWING AND AS DIRECTED BY THE ENGINEER:
 - a) ONE ROAD CONSTRUCTION AHEAD SIGN 36 x 36 (900x900) WITH A FLASHER AND FLAG MOUNTED ON IT APPROXIMATELY 200' (60 m) IN ADVANCE OF THE MAIN ROUTE.
 - b) THE CLOSED PORTION OF THE MAIN ROUTE SHALL BE PROTECTED BY BLOCKING WITH TYPE I, TYPE II OR TYPE III BARRICADES, 1/3 OF THE CROSS SECTION OF THE CLOSED PORTION.
 2. SIDE ROAD WITH A SPEED LIMIT GREATER THAN 40 MPH (60 km/h) AS SHOWN ON THE DRAWING AND AS DIRECTED BY THE ENGINEER:
 - a) ONE ROAD CONSTRUCTION AHEAD SIGN 48 x 48 (1.2 m x 1.2 m) WITH A FLASHER MOUNTED ON IT APPROXIMATELY 500' (150 m) IN ADVANCE OF THE MAIN ROUTE.
 - b) THE CLOSED PORTION OF THE MAIN ROUTE SHALL BE PROTECTED BY BLOCKING WITH TYPE III BARRICADES, 1/2 OF THE CROSS SECTION OF THE CLOSED PORTION.
 - 3. WHEN THE SIDE ROAD LIES BETWEEN THE BEGINNING OF THE MAINLINE SIGNING AND THE WORK ZONE, A SINGLE HEADED ARROW (M6-1) SHALL BE USED IN LIEU OF THE DOUBLE HEADED ARROW (M6-4).
- B. FOR A LANE CLOSURE ON A SIDE ROAD OR DRIVEWAY:

USE APPLICABLE PORTIONS OF THE TYPICAL APPLICATION OF TRAFFIC CONTROL DEVICES (STD. 701501, STD. 701606 OR THE APPROPRIATE STANDARD). THE SPACING OF SIGNS AND BARRICADES SHALL BE ADJUSTED FOR FIELD CONDITIONS AS DIRECTED BY THE ENGINEER. THE DIRECTIONAL ARROW SHALL BE COVERED OR REMOVED WHEN NO LONGER CONSISTENT WITH THE SIDE ROAD LANE CLOSURE.
 - C. ADVANCE WARNING SIGNS ARE TO BE OMITTED ON DRIVEWAY UNLESS OTHERWISE NOTED.
 - D. THE TRAFFIC CONTROL AND PROTECTION FOR SIDE ROADS, INTERSECTIONS, AND DRIVEWAYS SHALL BE INCIDENTAL TO THE COST OF SPECIFIED TRAFFIC CONTROL STANDARDS OR ITEMS.

All dimensions are in millimeters (inches) unless otherwise shown.

COMPANY NAME: #/COMPANY NAME/
 PROJECT CONTACT: #/PROJECT CONTACT/
 CLIENT: #/CLIENT/
 DATE PLOTTED: 10/18/2011 9:18:54 AM
 FILE NAME: 0610019606-081-06-09p
 PLOT DRIVER: pdf_dwt-jit-11ff.dpt
 PEN TABLE: standard-trans.tbl



USER NAME = gaglianobt	DESIGNED - LHA	REVISED - J. OBERLE 10-18-95
PLOT SCALE = 50.000' / IN.	DRAWN -	REVISED - A. HOUSEH 03-06-96
PLOT DATE = 1/4/2008	CHECKED -	REVISED - A. HOUSEH 10-15-96
	DATE - 06-89	REVISED - T. RAMMACHER 01-06-00

STATE OF ILLINOIS
 DEPARTMENT OF TRANSPORTATION

TRAFFIC CONTROL AND PROTECTION FOR SIDE ROADS, INTERSECTIONS, AND DRIVEWAYS		
SCALE: NONE	SHEET NO. 1 OF 1 SHEETS	STA. TO STA.

F.A. RTE.	SECTION	COUNTY	TOTAL SHEETS	SHEET NO.
	534X-RS-5	DUPAGE	35	29
TC-10		CONTRACT NO. 60N43		
FED. ROAD DIST. NO. 1 ILLINOIS FED. AID PROJECT				

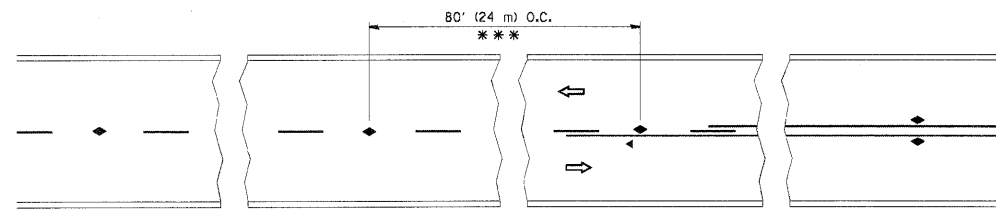

*** REDUCE TO 40' (12 m) O.C. ON CURVES WITH POSTED OR ADVISORY SPEED 45 M.P.H. (70 km/h) OR LESS.

TWO-LANE/TWO-WAY

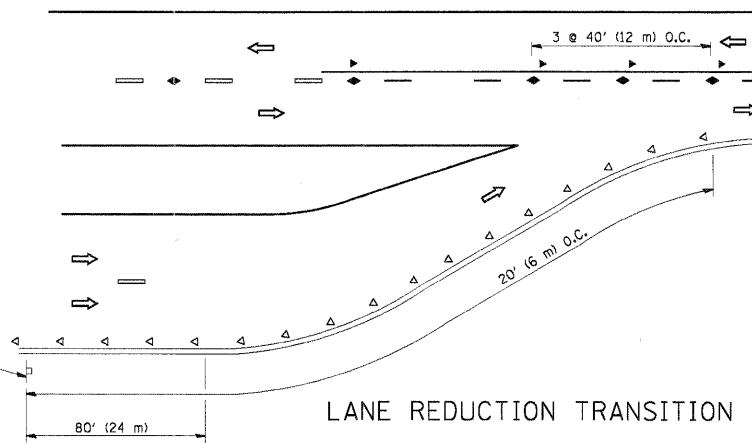

LANE REDUCTION TRANSITION

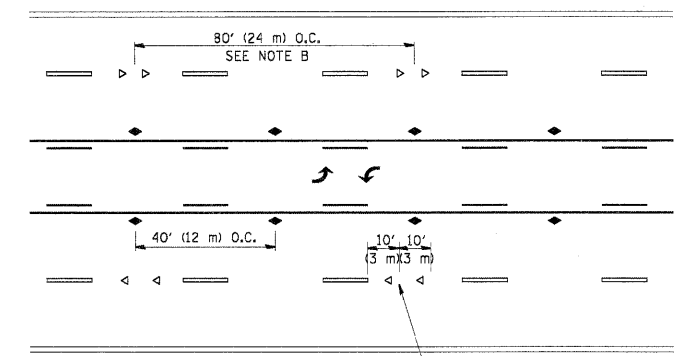

TWO-WAY LEFT TURN

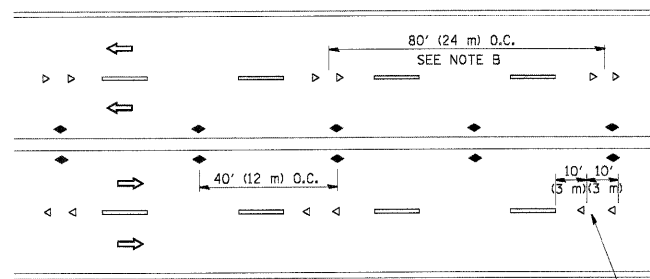

MULTI-LANE/UNDIVIDED

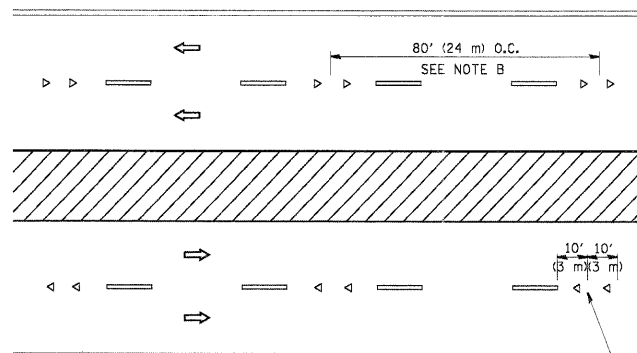

MULTI-LANE/DIVIDED

GENERAL NOTES

1. MARKERS USED WITH DASHED LINES SHALL BE CENTERED IN THE GAP BETWEEN SEGMENTS.
2. MARKERS USED ADJACENT TO SOLID LINES SHALL BE OFFSET 2 TO 3 (50 TO 75) TOWARD TRAFFIC AS SHOWN.
3. MARKERS THROUGH TANGENTS LESS THAN 500' (150 m) IN LENGTH BETWEEN CURVES SHALL BE INSTALLED AT THE LESSER OF THE TWO CURVE SPACINGS.

SYMBOLS

- YELLOW STRIPE
- WHITE STRIPE
- ◀ ONE-WAY AMBER MARKER
- ◁ ONE-WAY CRYSTAL MARKER (W/D)
- ◆ TWO-WAY AMBER MARKER

LANE MARKER NOTES

- A. USE DOUBLE LANE LINE MARKERS SPACED AS SHOWN.
- B. REDUCE TO 40' (12 m) O.C. ON CURVES WHERE ADVISORY SPEEDS ARE 10 M.P.H (20 km/h) LOWER THAN POSTED SPEEDS.

DESIGN NOTES

1. DOUBLE LANE LINE MARKERS SHALL BE USED UNLESS SPECIFIED OTHERWISE.
2. EXCEPT AS SHOWN ON THE LANE REDUCTION TRANSITION AND FREEWAY EXIT RAMP DETAIL, MARKERS ARE NOT TO BE SPECIFIED ON RIGHT EDGE LINES.
3. THE EXACT MARKER LIMITS, SPACING, AND COLOR SHOULD BE INCLUDED IN THE PLANS.
4. MARKERS SHOULD NOT BE USED ALONGSIDE CURBS EXCEPT FOR EXTREMELY SHORT SECTIONS OF CURBS WHERE NOT MORE THAN TWO MARKERS WOULD BE INVOLVED.

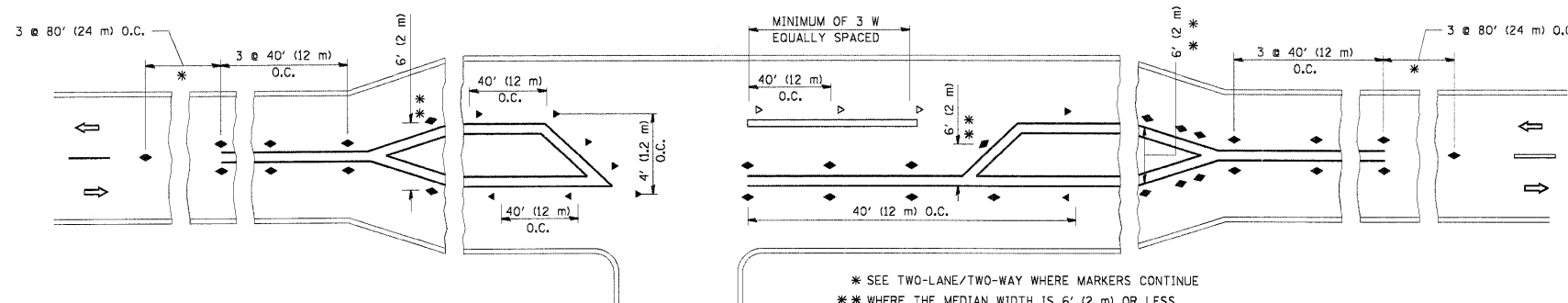

LEFT TURN

* SEE TWO-LANE/TWO-WAY WHERE MARKERS CONTINUE
 ** WHERE THE MEDIAN WIDTH IS 6' (2 m) OR LESS USE TWO-WAY MARKERS.

All dimensions are in inches (millimeters) unless otherwise shown.

COMPANY NAME: HRGreen
 PROJECT CONTACT: #PROJECT_CONTACT1
 CLIENT: #CLIENT
 DATE PLOTTED: 10/18/2011 5:12:18 PM
 FILE NAME: 86100196.06-06-01.dgn
 PLOT DRIVER: Def-DEF-D1-T11.dpt
 PEN TABLE: Standard-Trans.tbl



USER NAME = dr:vekogn	DESIGNED -	REVISED - T. RAMMACHER 09-19-94
PLOT SCALE = 50,000 / IN.	DRAWN -	REVISED - T. RAMMACHER 03-12-99
PLOT DATE = 9/9/2009	CHECKED -	REVISED - T. RAMMACHER 01-06-00
	DATE -	REVISED - C. JUCIUS 09-09-09

STATE OF ILLINOIS
 DEPARTMENT OF TRANSPORTATION

TYPICAL APPLICATIONS		
RAISED REFLECTIVE PAVEMENT MARKERS (SNOW-PLOW RESISTANT)		
SCALE: NONE	SHEET NO. 1 OF 1 SHEETS	STA. TO STA.

F.A. RTE.	SECTION	COUNTY	TOTAL SHEETS	SHEET NO.
	534X-RS-5	DUPAGE	35	30
TC-11			CONTRACT NO. 60N43	
FED. ROAD DIST. NO. 1 ILLINOIS FED. AID PROJECT				

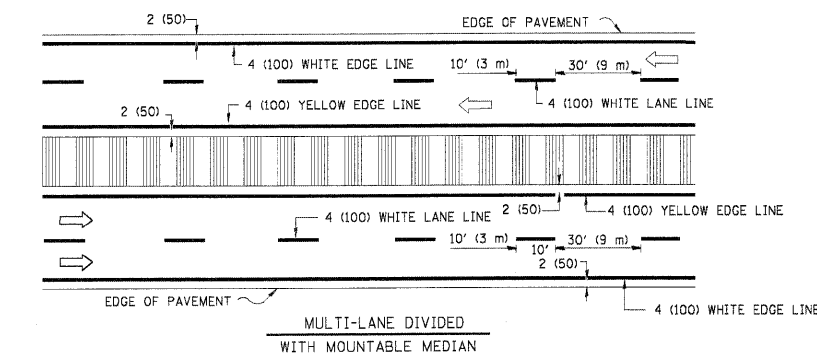
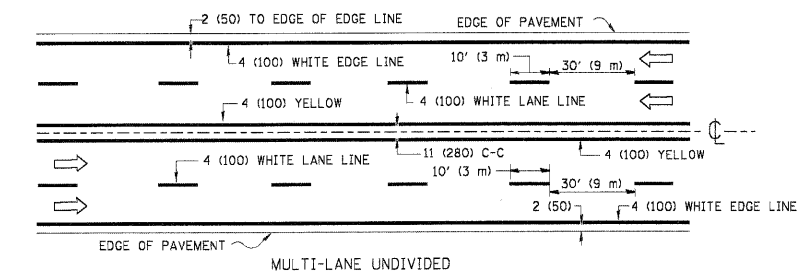
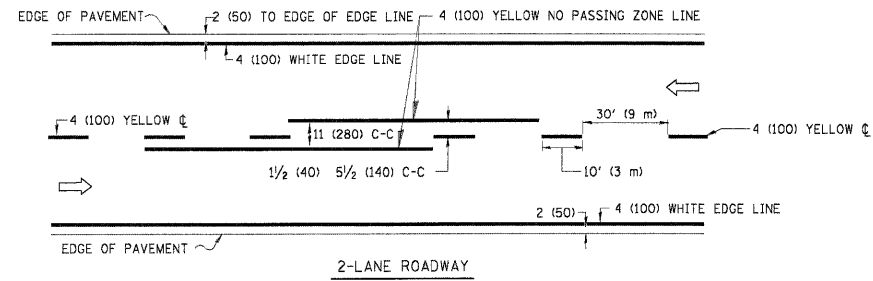

NOTE: MEDIANS WITH BARRIER CURB DO NOT REQUIRE AN EDGE LINE

TYPICAL LANE AND EDGE LINE MARKING

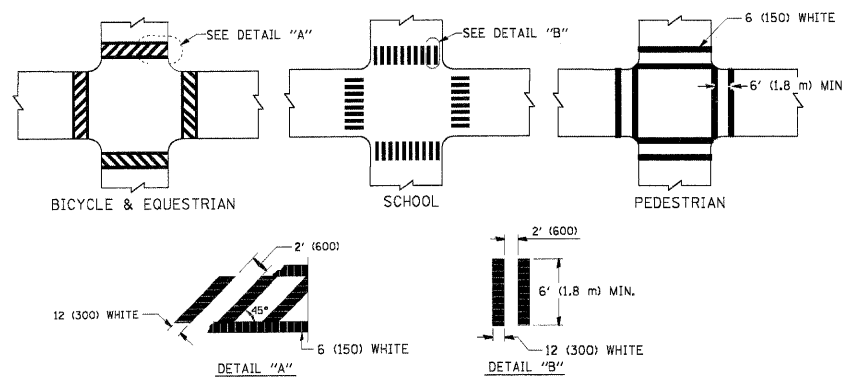

TYPICAL CROSSWALK MARKING

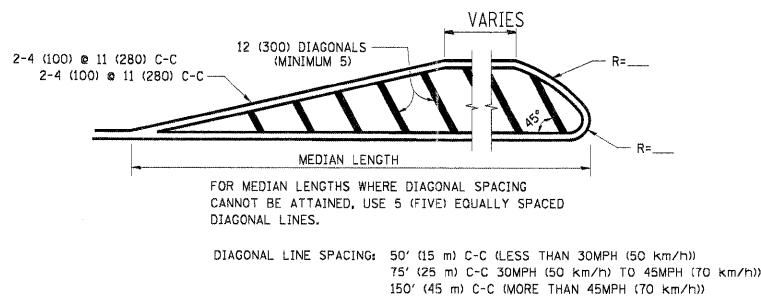
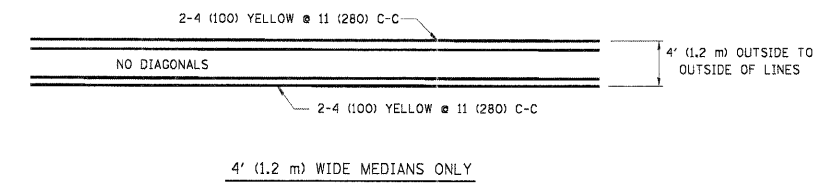

MEDIANS OVER 4' (1.2 m) WIDE

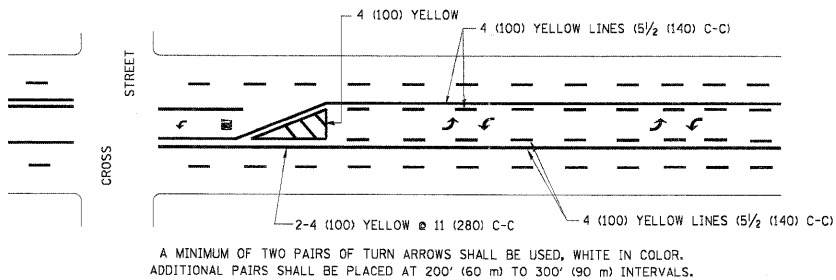

MEDIAN WITH TWO-WAY LEFT TURN LANE

TYPICAL PAINTED MEDIAN MARKING

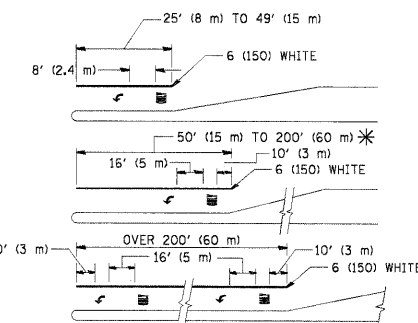

FULL SIZE LETTERS 8' (2.4 m) AND ARROWS SHALL BE USED.
AREA = 15.6 SQ. FT. (1.5 m²) ONLY AREA = 20.8 SQ. FT. (1.9 m²)

* TURN LANES IN EXCESS OF 400' (120 m) IN LENGTH MAY HAVE AN ADDITIONAL SET OF ARROW - "ONLY" INSTALLED MIDWAY BETWEEN THE OTHER TWO SETS OF ARROW - "ONLY".

TYPICAL LEFT (OR RIGHT) TURN LANE

TYPICAL TURN LANE MARKING

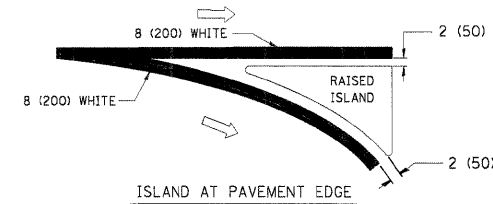
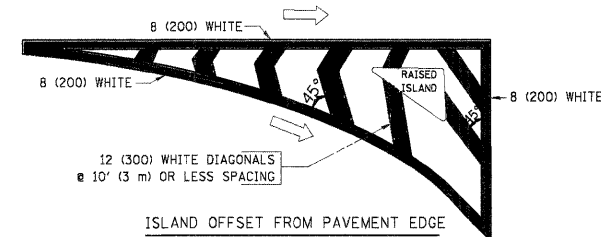

TYPICAL ISLAND MARKING

TYPE OF MARKING	WIDTH OF LINE	PATTERN	COLOR	SPACING / REMARKS
CENTERLINE ON 2 LANE PAVEMENT	4 (100)	SKIP-DASH	YELLOW	10' (3 m) LINE WITH 30' (9 m) SPACE
CENTERLINE ON MULTI-LANE UNDIVIDED PAVEMENT	2 @ 4 (100)	SOLID	YELLOW	11 (280) C-C
NO PASSING ZONE LINES FOR ONE DIRECTION FOR BOTH DIRECTIONS	4 (100) 2 @ 4 (100)	SOLID SOLID	YELLOW YELLOW	5 1/2 (140) C-C FROM SKIP-DASH CENTERLINE 11 (280) C-C OMIT SKIP-DASH CENTERLINE BETWEEN
LANE LINES	4 (100) 5 (125) ON FREEWAYS	SKIP-DASH SKIP-DASH	WHITE WHITE	10' (3 m) LINE WITH 30' (9 m) SPACE
DOTTED LINES (EXTENSIONS OF CENTER, LANE OR TURN LANE MARKINGS)	SAME AS LINE BEING EXTENDED	SKIP-DASH	SAME AS LINE BEING EXTENDED	2' (600) LINE WITH 6' (1.8 m) SPACE
EDGE LINES	4 (100)	SOLID	YELLOW-LEFT WHITE-RIGHT	OUTLINE MOUNTABLE MEDIANS IN YELLOW; EDGE LINES ARE NOT USED NEXT TO BARRIER CURB
TURN LANE MARKINGS	6 (150) LINE, FULL SIZE LETTERS & SYMBOLS (8' (2.4m))	SOLID	WHITE	SEE TYPICAL TURN LANE MARKING DETAIL
TWO WAY LEFT TURN MARKING	2 @ 4 (100) EACH DIRECTION 8' (2.4m) LEFT ARROW	SKIP-DASH AND SOLID IN PAIRS	YELLOW WHITE	10' (3 m) LINE WITH 30' (9 m) SPACE FOR SKIP-DASH; 5 1/2 (140) C-C BETWEEN SOLID LINE AND SKIP-DASH LINE SEE TYPICAL TWO-WAY LEFT TURN MARKING DETAIL
CROSSWALK LINES (PEDESTRIAN) A. DIAGONALS (BIKE & EQUESTRIAN) B. LONGITUDINAL BARS (SCHOOL)	2 @ 6 (150) 12 (300) @ 45° 12 (300) @ 90°	SOLID SOLID SOLID	WHITE WHITE WHITE	NOT LESS THAN 6' (1.8 m) APART 2' (600) APART 2' (600) APART SEE TYPICAL CROSSWALK MARKING DETAILS.
STOP LINES	24 (600)	SOLID	WHITE	PLACE 4' (1.2 m) IN ADVANCE OF AND PARALLEL TO CROSSWALK, IF PRESENT. OTHERWISE, PLACE AT DESIRED STOPPING POINT, PARALLEL TO CROSSROAD CENTERLINE, WHERE POSSIBLE
PAINTED MEDIANS	2 @ 4 (100) WITH 12 (300) DIAGONALS @ 45° NO DIAGONALS USED FOR 4' (1.2 m) WIDE MEDIANS	SOLID	YELLOW; TWO WAY TRAFFIC WHITE; ONE WAY TRAFFIC	11 (280) C-C FOR THE DOUBLE LINE SEE TYPICAL PAINTED MEDIAN MARKING.
GORE MARKING AND CHANNELIZING LINES	8 (200) WITH 12 (300) DIAGONALS @ 45°	SOLID	WHITE	DIAGONALS: 15' (4.5 m) C-C (LESS THAN 30MPH (50 km/h)) 20' (6 m) C-C 30MPH (50 km/h) TO 45MPH (70 km/h) 30' (9 m) C-C (OVER 45MPH (70 km/h))
RAILROAD CROSSING	24 (600) TRANSVERSE LINES; "RR" IS 6' (1.8 m) LETTERS; 16 (400) LINE FOR "X"	SOLID	WHITE	SEE STATE STANDARD 780001 AREA OF: "R"=3.6 SQ. FT. (0.33 m ²) EACH "X"=54.0 SQ. FT. (5.0 m ²)
SHOULDER DIAGONALS	12 (300) @ 45°	SOLID	WHITE - RIGHT YELLOW - LEFT	50' (15 m) C-C (LESS THAN 30MPH (50 km/h)) 75' (25 m) C-C 30 MPH (50 km/h) TO 45MPH (70 km/h) 150' (45 m) C-C (OVER 45MPH (70 km/h))

FOR FURTHER DETAILS ON PAVEMENT MARKING REFER TO STANDARD SPECIFICATIONS FOR ROAD AND BRIDGE CONSTRUCTION AND STATE STANDARD 780001.

All dimensions are in inches (millimeters) unless otherwise shown.

COMPANY NAME: HRGreen.com
PROJECT CONTACT: #PROJECT CONTACT
CLIENT: #CLIENT
DATE PLOTTED: 10/18/2011 9:58:57 AM
FILE NAME: 86100196-06-061-08.dgn
PLOT DRIVER: pdfLDT-DI-TTF.pdf
PEN TABLE: \$fontcolor=trans.tbl



USER NAME = drivakosgn
DESIGNED - EVERS
DRAWN -
CHECKED -
DATE - 03-19-90

DESIGNED - EVERS
DRAWN -
CHECKED -
DATE - 03-19-90

STATE OF ILLINOIS
DEPARTMENT OF TRANSPORTATION

DISTRICT ONE
TYPICAL PAVEMENT MARKINGS

SCALE: NONE SHEET NO. 1 OF 1 SHEETS STA. TO STA.

F.A. RTE.	SECTION	COUNTY	TOTAL SHEETS	SHEET NO.
	534X-RS-5	DUPAGE	35	31
TC-13			CONTRACT NO. 60N43	
FED. ROAD DIST. NO. 1 ILLINOIS FED. AID PROJECT				

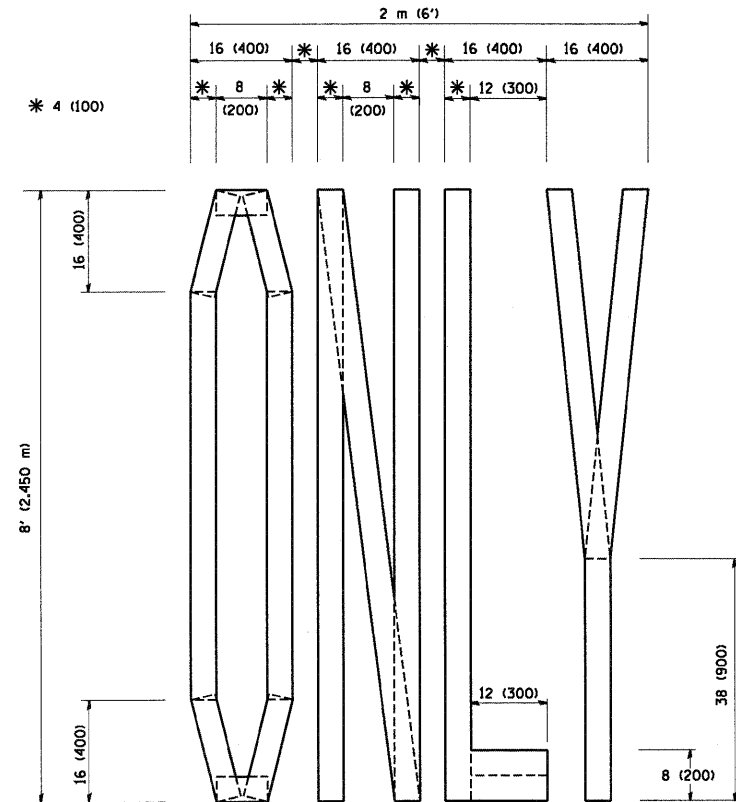

QUANTITY
 4 (100) LINE = 64.1 ft. (19.7 m)
 21.1 sq. ft. (1.97 sq. m)

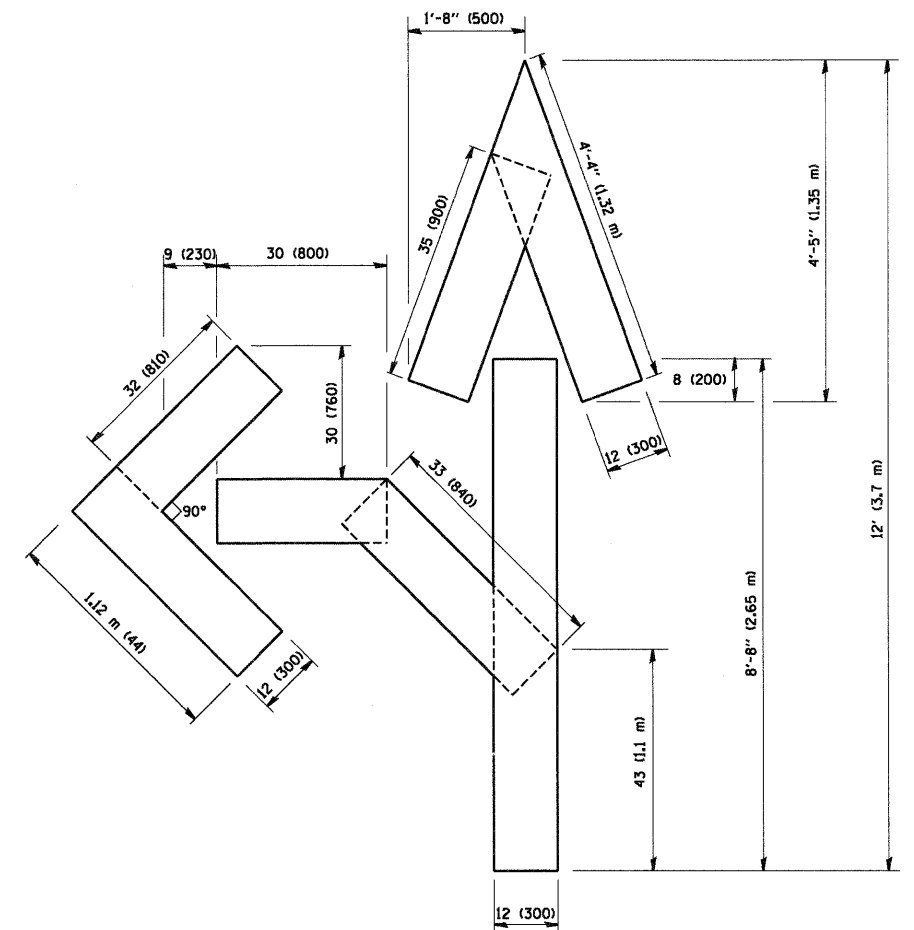

QUANTITY
 4 (100) LINE = 82.5 ft. (25.3 m)
 27.5 sq. ft. (2.53 sq. m)

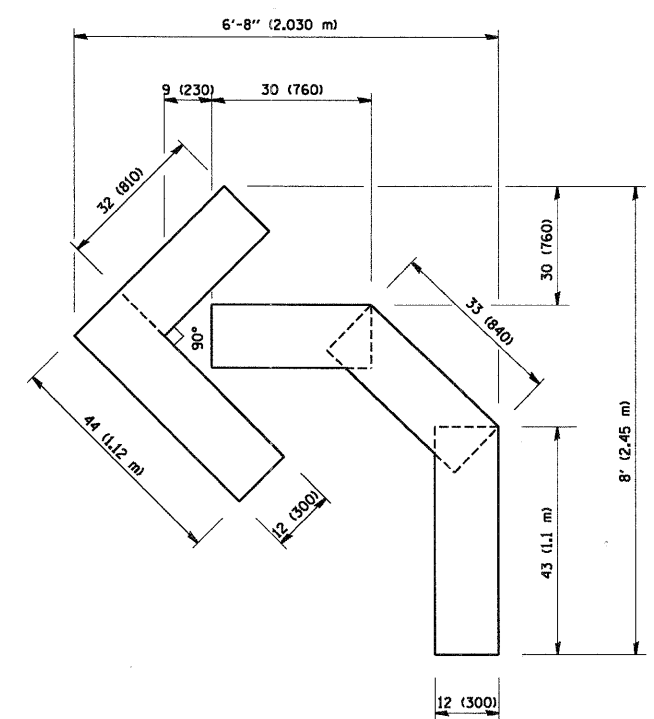

QUANTITY
 4 (100) LINE = 45.5 ft. (13.9 m)
 15.2 sq. ft. (1.39 sq. m)

All dimensions are in inches (millimeters) unless otherwise shown.

COMPANY NAME: HRGreen
 PROJECT CONTACT: #PROJECT CONTACT
 CLIENT: #CLIENT
 DATE PLOTTED: 10/18/2011 9:08:59 AM
 FILE NAME: 86100196.06-061-09.dgn
 PLOT DRIVER: pdfLDEF-01-TIFF.plt
 PEN TABLE: standard-trans.tbl



USER NAME = geglsenobt	DESIGNED -	REVISED - T. RAMMACHER 06-05-96
	DRAWN -	REVISED - T. RAMMACHER 11-04-97
PLOT SCALE = 50.0000" / IN.	CHECKED -	REVISED - T. RAMMACHER 03-02-98
PLOT DATE = 1/4/2008	DATE - 09-18-94	REVISED - E. GOMEZ 08-28-00

STATE OF ILLINOIS
 DEPARTMENT OF TRANSPORTATION

PAVEMENT MARKING LETTERS AND SYMBOLS
 FOR TRAFFIC STAGING

SCALE: NONE SHEET NO. 1 OF 1 SHEETS STA. TO STA.

F.A. RTE.	SECTION	COUNTY	TOTAL SHEETS	SHEET NO.
	534X-RS-5	DUPAGE	35	32
	TC-16	CONTRACT NO.	60N43	
FED. ROAD DIST. NO. 1 ILLINOIS FED. AID PROJECT				

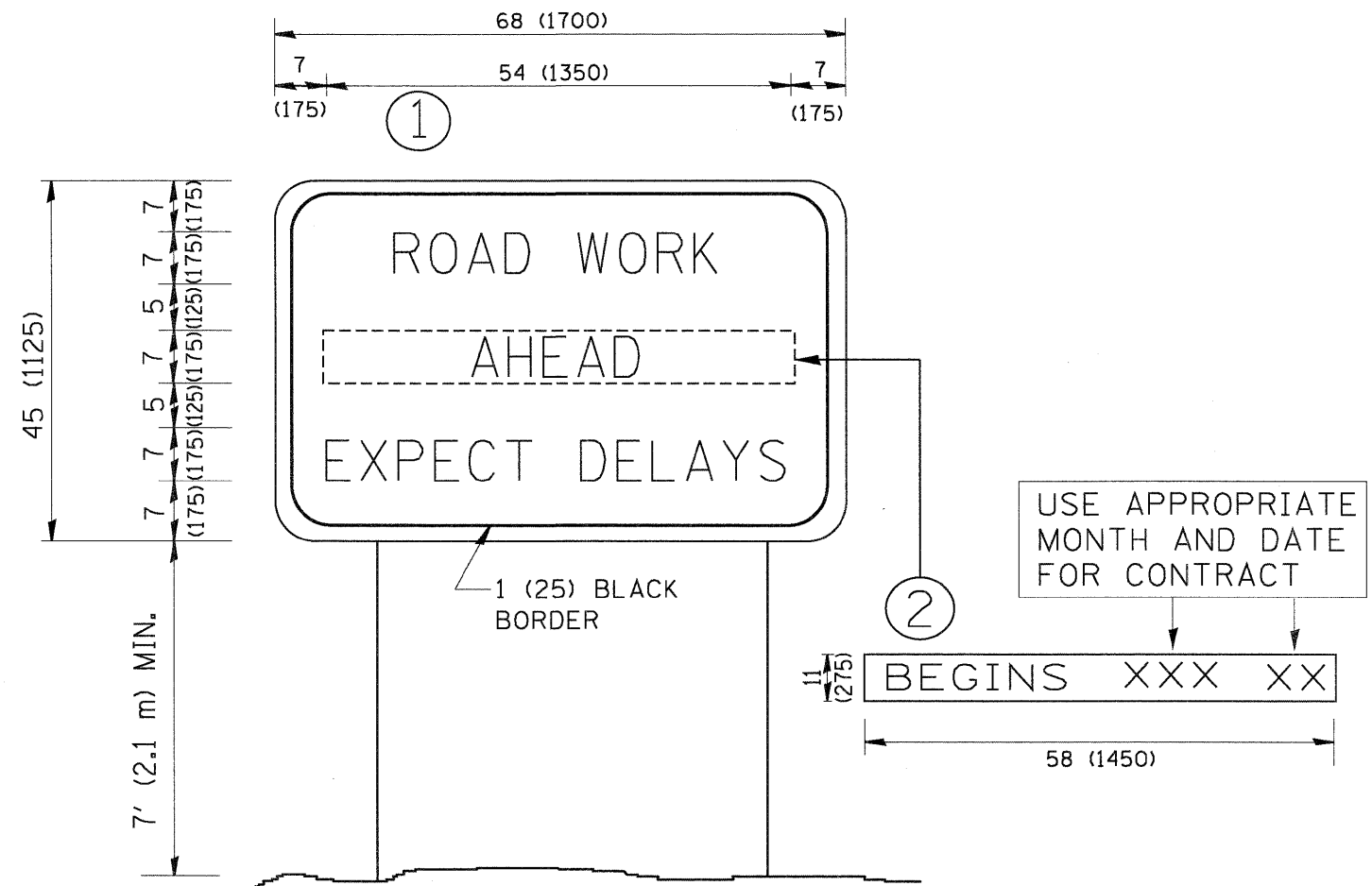

NOTES:

1. USE BLACK LETTERING ON ORANGE BACKGROUND.
2. ERECT SIGNS IN ADVANCE OF THE LOCATION FOR THE "ROAD CONSTRUCTION AHEAD" SIGN AT LOCATIONS AS DIRECTED BY THE ENGINEER.
3. ERECT SIGN ① WITH INSTALLED PANEL ② ONE WEEK PRIOR TO THE START OF CONSTRUCTION.
4. REMOVE PANEL ② SOON AFTER THE START OF CONSTRUCTION.
5. SEE SPECIAL PROVISION FOR "TEMPORARY INFORMATION SIGNING" FOR ADDITIONAL INFORMATION.
6. ONE SIGN ASSEMBLY EQUALS 25.70 SQ. FT. (2.3 SQ. M.)
7. SHALL BE PAID FOR AS TEMPORARY INFORMATION SIGNING.

ALL DIMENSIONS ARE IN INCHES (MILLIMETERS)
UNLESS OTHERWISE SHOWN.

COMPANY NAME: #PROJECT_CONTACT
PROJECT CONTACT: #CLIENT
CLIENT: 10/18/2011 9:59:02 AM
DATE PLOTTED: 8/6/2010 9:06:06 AM
FILE NAME: pdf_def-01-11ff.pdf
PLOT DRIVER: standard-trans.tbl
PEN TABLE:



USER NAME = geglienobt	DESIGNED -	REVISED - R. MIRS 09-15-97
	DRAWN -	REVISED - R. MIRS 12-11-97
PLOT SCALE = 50.0000 1/16 IN.	CHECKED -	REVISED - T. RAMMACHER 02-02-99
PLOT DATE = 1/4/2008	DATE -	REVISED - C. JUCIUS 01-31-07

STATE OF ILLINOIS
DEPARTMENT OF TRANSPORTATION

ARTERIAL ROAD
INFORMATION SIGN

SCALE: NONE SHEET NO. 1 OF 1 SHEETS STA. TO STA.

F.A. RTE.	SECTION	COUNTY	TOTAL SHEETS	SHEET NO.
	534X-RS-5	DUPAGE	35	33
TC-22			CONTRACT NO. 60N43	
FED. ROAD DIST. NO. 1 ILLINOIS FED. AID PROJECT				

LOOP DETECTOR NOTES

1. EACH PAIR OF LOOP WIRES SHALL BE PLACED IN A SEPARATE EMPTY COILABLE NONMETALLIC CONDUIT FROM THE EDGE OF PAVEMENT TO THE HANDHOLE. SPACING BETWEEN THE HOLES DRILLED IN THE PAVEMENT SHALL NOT BE LESS THAN 6" (150 mm). EMPTY COILABLE NONMETALLIC CONDUIT SHALL BE INCLUDED IN THE COST OF THE LOOP WIRE.
2. THE NUMBER OF LOOP TURNS SHALL BE AS RECOMMENDED BY THE AMPLIFIER MANUFACTURER. ALL ADJACENT SIDES OF THE LOOPS SHALL BE INSTALLED IN SUCH A WAY THAT THE CURRENT FLOW IS IN THE SAME DIRECTION TO REINFORCE ITS MAGNETIC FIELDS FOR SMALL VEHICLE DETECTION.
3. EACH LOOP LEAD-IN SHALL BE IDENTIFIED AND PERMANENTLY TAGGED IN THE HANDHOLE. EACH LEAD-IN CABLE TAG SHALL INDICATE THE LOCATION OF THE LOOP, LOOP ROTATION (CLOCKWISE/COUNTERCLOCKWISE), LOOP LEAD-IN DIRECTION (IN OR OUT), LOOP CABLE NUMBER AND LOCATION IN CABINET, AND NUMBER OF TURNS IN THE DETECTOR LOOPS IN WATER PROOF INK AS INDICATED ON THE DISTRICT 1 STANDARD TRAFFIC SIGNAL DESIGN DETAIL. THE CONTRACTOR SHALL MARK LOOP LOCATIONS ON RECORD DRAWINGS AND PRESENT TO THE ENGINEER AFTER FINAL INSPECTION. LOOPS SHALL BE MARKED BY LANE AND LOOP NUMBER. SEE DETAIL BELOW.
4. ALL LOOP CABLE SHALL BE FASTENED WITH PLASTIC TIE WRAP TO THE HANDHOLE HOOKS.
5. IN ASPHALT PAVEMENT, LOOPS SHOULD BE PLACED IN THE BINDER AND DIVESHOLES MARKED AT THE CURB WITH A SAW-CUT. THE SAW-CUT SHALL BE CUT IN ACCORDANCE WITH LOCAL AND E.P.A. DUST CONTROL REQUIREMENTS. DETECTOR LOOP(S) SHALL NOT BE INSTALLED IN WET CONDITIONS AND THE SAW-CUTS MUST BE FREE OF DEBRIS AND RESIDUE SUCH AS DUST AND WATER WHICH IS TO BE ACHIEVED BY THE USE OF COMPRESSED AIR, WIRE BRUSHING AND HEAT DRYING ACCORDING TO SEALANT MANUFACTURER REQUIREMENTS. THE DETECTOR WIRE SHALL BE HELD IN PLACE BY THE USE OF FORM WEDGES. WEDGES SHALL BE SPACED NO MORE THAN 18" (450 mm) APART.
6. LOOP SPLICES SHALL BE SOLDERED USING A SOLDERING IRON. BLOW TORCHES OR OTHER DEVICES WHICH OXIDIZE COPPER CABLE SHALL NOT BE ALLOWED FOR SOLDERING OPERATIONS. SEE DETAIL BELOW RIGHT.
7. PREFORMED DETECTOR LOOPS SHALL BE USED, AS SHOWN ON THE PLANS, WHERE NEW CONCRETE PAVEMENT IS PROPOSED. THE INSTALLATION OF PREFORMED LOOPS SHALL BE IN ACCORDANCE WITH THE DISTRICT 1 SPECIFICATIONS OR AS DIRECTED BY THE ENGINEER.

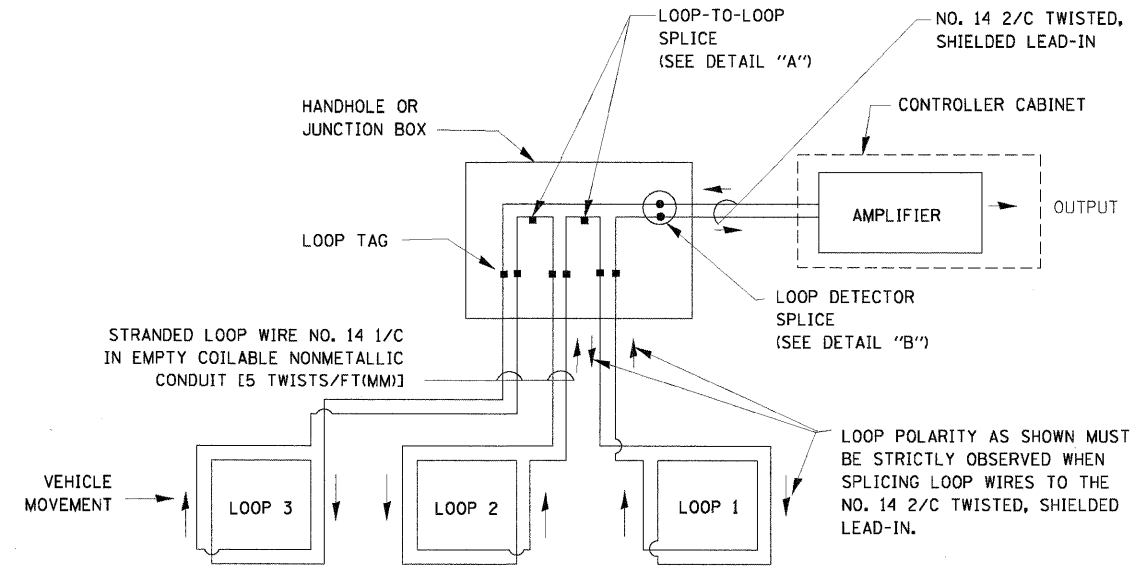

DETECTOR LOOP WIRING SCHEMATIC

- LOOPS SHALL BE SPLICED IN SERIES.
- SAW-CUTS SHALL BE A MINIMUM WIDTH OF 5/16" (8 mm).
- SAW-CUT DEPTHS SHALL BE 3" (75 mm). IF IN CONCRETE, THE SAW-CUT DEPTH SHALL BE TO THE TOP OF THE REINFORCEMENT.
- LOOP CORNERS SHALL BE DRILLED WITH A 2" (50 mm) DIAMETER CORE.

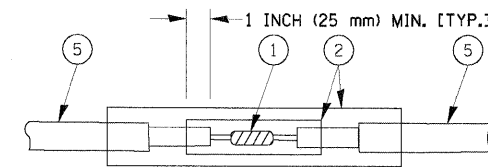

DETAIL "A" LOOP-TO-LOOP SPLICE

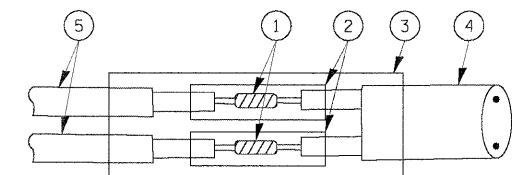

DETAIL "B" LOOP-TO-CONTROLLER SPLICE

TYPE I LOOP

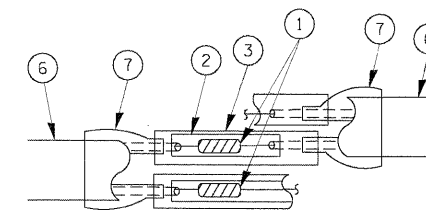

DETAIL "A" LOOP-TO-LOOP SPLICE

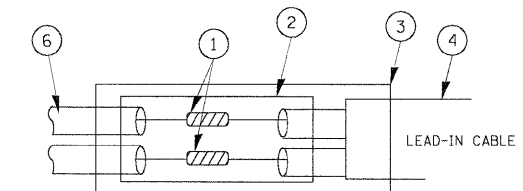

DETAIL "B" LOOP-TO-CONTROLLER SPLICE

LOOP LEAD-IN CABLE TAG

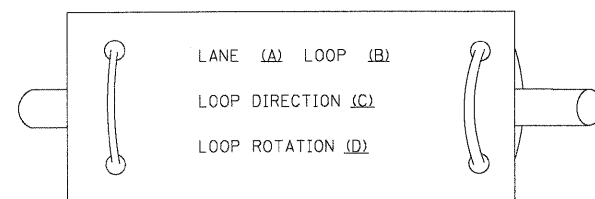

- A. LANE 1 IS THE LANE CLOSEST TO THE CENTERLINE OF THE ROADWAY
- B. LOOP #1 IS THE LOOP IN THE LANE CLOSEST TO THE INTERSECTION.
- C. LABEL LOOP CABLE "IN" OR LOOP CABLE "OUT".
- D. LABEL LOOP CABLE CLOCKWISE OR LOOP CABLE COUNTERCLOCKWISE.

LOOP DETECTOR SPLICE

- 1 WESTERN UNION SPLICE SOLDERED WITH ROSIN CORE FLUX. ALL EXPOSED SURFACES OF THE SOLDER SHALL BE SMOOTH.
- 2 WCSMW 30/100 HEAT SHRINK TUBE, MINIMUM LENGTH 3" (75 mm), UNDERWATER GRADE.
- 3 WCS 200/750 HEAT SHRINK TUBE, MINIMUM LENGTH 6" (150 mm), UNDERWATER GRADE.
- 4 NO. 14 2/C TWISTED, SHIELDED CABLE.
- 5 LOOP CONDUCTOR WITH FLEXIBLE PLASTIC TUBE.
- 6 PRE-FORMED LOOP
- 7 XL POLYOLEFIN 2 CONDUCTOR BREAKOUT SEALS. TYCO CBR-2 OR APPROVED EQUAL

COMPANY NAME: #COMPANY NAME
 PROJECT CONTACT: #PROJECT CONTACT
 CLIENT: #CLIENT
 DATE PLOTTED: 10/18/2001 9:19:03 AM
 FILE NAME: 66000906-08-11.dgn
 PLOT DRIVER: pdf-01-11f.pdf
 PEN TABLE: standard-trans.tbl



USER NAME = bauerd1	DESIGNED - DAD	REVISED -
PLOT SCALE = 50.0000' / IN.	DRAWN - BCK	REVISED -
PLOT DATE = 11/14/2009	CHECKED - DAD	REVISED -
	DATE - 10-28-09	REVISED -

**STATE OF ILLINOIS
 DEPARTMENT OF TRANSPORTATION**

DISTRICT ONE	
STANDARD TRAFFIC SIGNAL DESIGN DETAILS	
SCALE: NONE	SHEET NO. 1 OF 1 SHEETS
STA.	TO STA.

F.A. RTE.	SECTION	COUNTY	TOTAL SHEETS	SHEET NO.
	534X-RS-5	DUPAGE	35	34
TS-05		CONTRACT NO. 60N43		
FED. ROAD DIST. NO. 1 ILLINOIS FED. AID PROJECT				

LOOPS NEXT TO SHOULDERS

PROVIDE A PAVEMENT REPLACEMENT NOTE WHICH SHOULD EQUAL 3' (900 mm) X WIDTH OF PAVED SHOULDER.

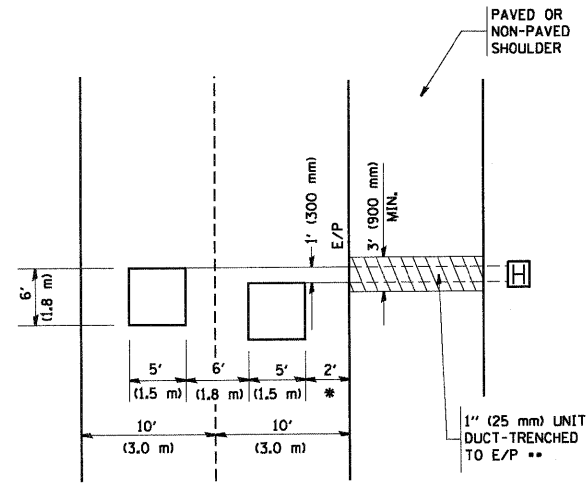

* = (600 mm)

** UNIT DUCT IS TO BE SHOWN ON PLAN SHEETS BUT SHALL NOT BE INCLUDED IN THE PAY ITEMS.

**LEFT TURN LANES WITH MEDIANS
VOLUME DENSITY ("FAR OUT" DETECTION)
ON SAME APPROACH
(PROTECTED / PERMITTED LEFT TURN PHASING)**

HANDHOLE LOCATION MAY VARY DEPENDING ON GEOMETRICS AND DESIGN OF TRAFFIC SIGNALS. HEAVY-DUTY HANDHOLES TO BE USED WHEN THE MEDIAN IS MOUNTABLE. REFER TO STANDARD 814001 TO ENSURE THAT HANDHOLE FITS IN MEDIAN.

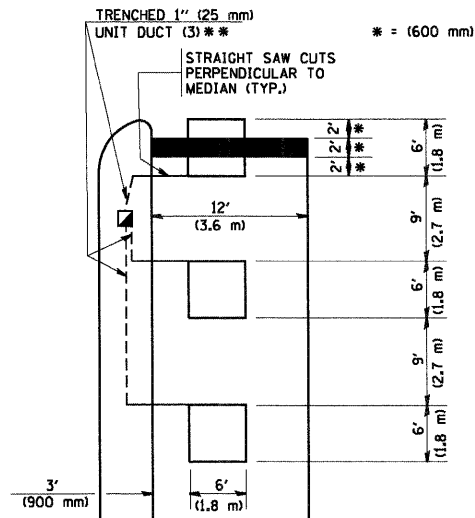

* = (600 mm)

** UNIT DUCT IS TO BE SHOWN ON PLAN SHEETS BUT SHALL NOT BE INCLUDED IN THE PAY ITEMS.

NOTE: DUAL LEFT TURNS NOT SHOWN REFER TO PLAN SHEET FOR DETECTOR LOOP REPLACEMENT

**LEFT TURN LANES WITHOUT MEDIANS
VOLUME DENSITY ("FAR OUT" DETECTION)
ON SAME APPROACH
(PROTECTED / PERMITTED LEFT TURN PHASING)**

* = (600 mm)

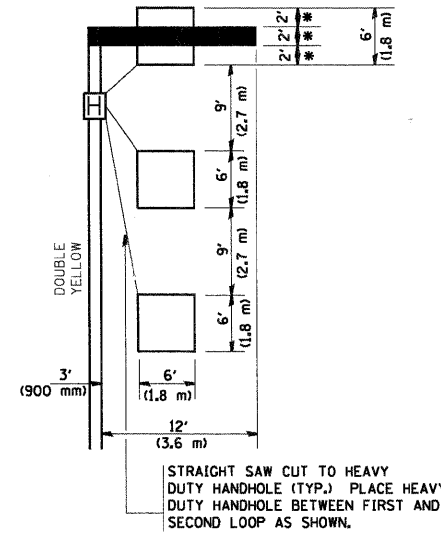

NOTE: DUAL LEFT TURNS NOT SHOWN REFER TO PLAN SHEET FOR DETECTOR LOOP REPLACEMENT

**ARTERIAL-VOLUME DENSITY ("FAR OUT" DETECTION)
CROSS STREET-VOLUME DENSITY ("FAR OUT" DETECTION)**

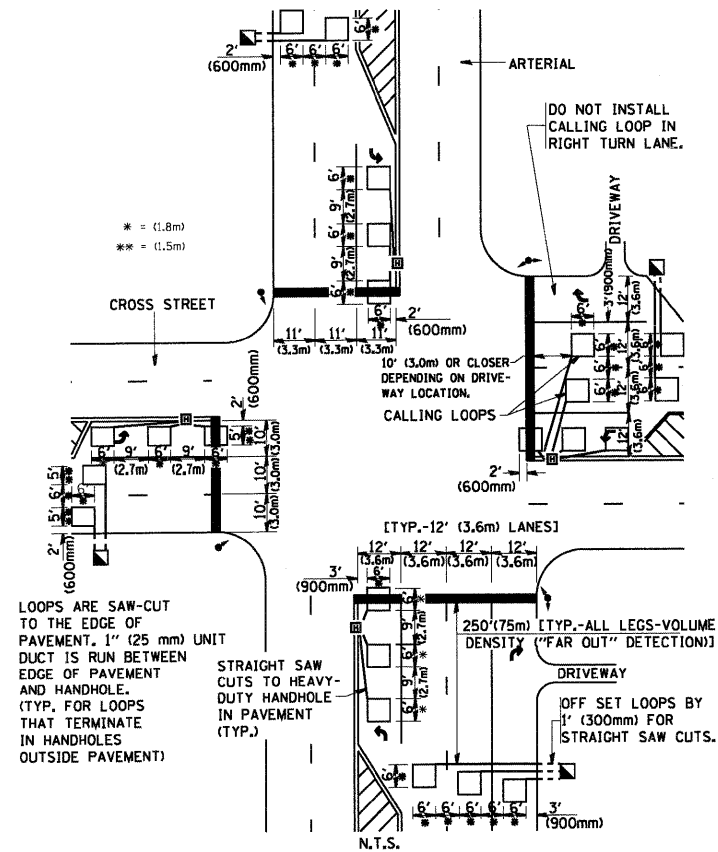

**DETAIL 1
N.T.S.**

**ARTERIAL-VOLUME DENSITY ("FAR OUT" DETECTION)
CROSS STREET-NON VOLUME DENSITY ("UPTIGHT" PRESENCE DETECTION)**

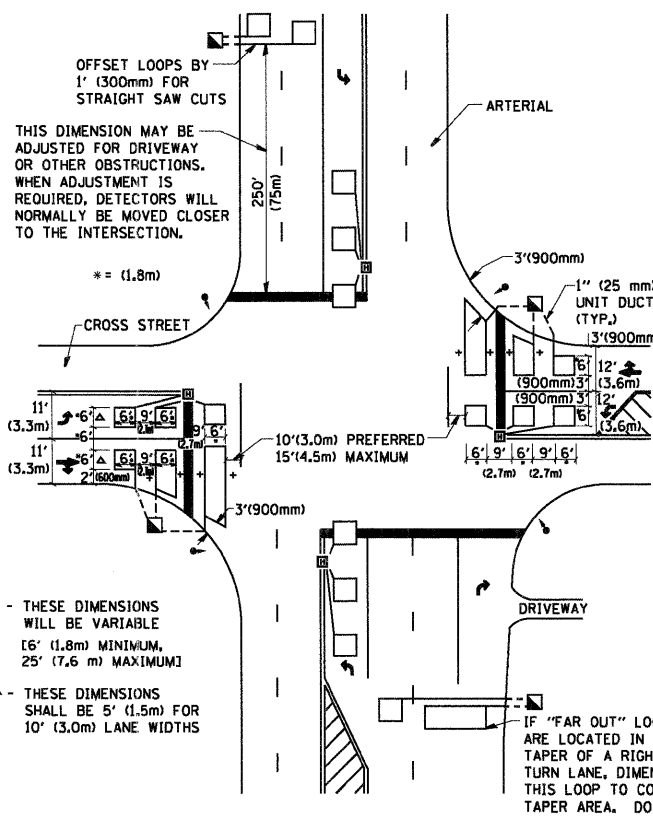

**DETAIL 2
N.T.S.**

NOTES:

VEHICLES LOOP DETECTORS

- * ALL LEAD IN CABLE SHALL BE TWO CONDUCTOR NO. 14 TWISTED, SHIELDED.
- * EACH DETECTOR LOOP SHALL HAVE ITS OWN SAW CUT FROM THE LOOP TO THE EDGE OF PAVEMENT OR TO A HANDHOLE IN THE PAVEMENT.
- * EACH DETECTOR LOOP SHALL HAVE ITS OWN ONE INCH (25 mm) UNIT DUCT BETWEEN THE EDGE OF PAVEMENT AND THE FIRST HANDHOLE OR JUNCTION BOX. EACH UNIT DUCT RUN SHALL BE SHOWN ON THE PLANS BY THE DESIGNER, BUT SHALL NOT BE PAID FOR SEPARATELY. THIS ITEM IS INCIDENTAL TO THE PAY ITEM FOR DETECTOR LOOPS.
- * ONE DIMENSION OF ALL DETECTOR LOOPS SHALL BE SIX FEET (1.8 m)
- * EACH LANE OF NON-LOCKING, PRESENCE DETECTION AND EACH LANE OF A DOUBLE LEFT TURN LANE REQUIRES A SEPARATE INDUCTIVE LOOP DETECTOR AND LEAD IN CABLE.
- * WHEN NON-LOCKING, PRESENCE DETECTION IS USED, MORE THAN ONE LOOP PER LANE IS REQUIRED BEHIND THE STOP BAR (I.e. 1-1/2, 1-3/4, 2).
- * WHEN SYSTEM LOOPS ARE REQUIRED ON AN APPROACH OF AN INTERSECTION, THE LOOPS USED FOR VOLUME DENSITY AND INTERSECTION TIMING SHALL ALSO BE USED AS SYSTEM DETECTORS. EACH ONE OF THESE TYPE OF LOOPS REQUIRES A SEPARATE TWO CONDUCTOR NO. 14 TWISTED SHIELDED CABLE AND A SEPARATE INDUCTIVE LOOP DETECTOR WHEN NEW CONTROLLERS ARE UTILIZED. THE DESIGNER SHALL LABEL THESE TYPES OF LOOPS AS "INTERSECTION AND SAMPLING (SYSTEM) DETECTORS" ON THE SIGNAL LAYOUT, THE INTERCONNECT PLAN AND THE SYSTEM CABLE PLAN. WHEN AN EXISTING CONTROLLER IS UTILIZED FOR THIS TYPE OF DETECTION, THE PAY ITEM "INDUCTIVE LOOP DETECTOR WITH SYSTEM OUTPUT" SHOULD BE USED.

PLACEMENT OF DETECTORS

THE FOLLOWING FIGURES REPRESENT THE MOST COMMON DETECTOR LOOP LOCATIONS AND SIZES. ADJUSTMENTS WILL BE NECESSARY FOR SPECIFIC GEOMETRIC CONSIDERATIONS.

LOCATIONS AND DEMENSIONS OF DETECTOR LOOPS ARE REQUIRED ON ALL SIGNAL LAYOUT PLAN SHEETS.

"FAR OUT" DETECTION REFERS TO LOCKING, PRESENCE TYPE DETECTION LOCATED IN THRU LANES, RIGHT TURN LANES, AND RIGHT TURN LANE TAPER AREAS (IF APPLICABLE), USUALLY 250' (75 m) IN ADVANCE OF STOP BARS. "UPTIGHT" DETECTION REFERS TO NON-LOCKING PRESENCE TYPE DETECTION LOCATED IN ALL LANES AND 10'-15' (3.0 m-4.5 m) BEHIND THE CROSSING STREET'S EDGE OF PAVEMENT EXTENDED.

NOTE:

ALL DETAILS AND NOTES SHOWN ARE FROM THE I.D.O.T. DISTRICT 1 TRAFFIC SIGNAL DESIGN GUIDELINES DATED JANUARY 1995

THIS DRAWING HAS BEEN PREPARED TO ASSIST THE RESIDENT ENGINEER FOR ALL ROADWAY RESURFACING OR S.M.A.R.T. PROJECTS WHERE THE DIMENSIONS ARE NOT SHOWN ON THE PLANS AND THE FINAL LOCATIONS FOR CROSSWALKS OR STOP BARS ARE NOT DETERMINED.

COMPANY NAME: HRGreen.com
PROJECT CONTACT: #PROJECT_CONTACT1
CLIENT: #CLIENT1
DATE PLOTTED: 10/18/2011 9:50:07 AM
FILE NAME: 86100196.06-061-12.dgn
PLOT DRIVER: pdf-DET-01-TIFF.plt
PEN TABLE: standard-trans.tbl



USER NAME = gaglianojb
DESIGNED -
DRAWN -
PLOT SCALE = 50.0000 1/1 IN.
CHECKED - R.K.F.
PLOT DATE = 1/4/2008

REVISIONS
REVISED -
REVISED -
REVISED -
REVISED -

DESIGNED -
DRAWN -
CHECKED - R.K.F.
DATE -

**STATE OF ILLINOIS
DEPARTMENT OF TRANSPORTATION**

**DISTRICT 1 - DETECTOR LOOP INSTALLATION
DETAILS FOR ROADWAY RESURFACING**

SCALE: NONE SHEET NO. 1 OF 1 SHEETS STA. TO STA.

F.A. RTE.	SECTION	COUNTY	TOTAL SHEETS	SHEET NO.
	534X-RS-5	DUPAGE	35	35
	TS-07	CONTRACT NO.	60N43	
FED. ROAD DIST. NO. 1 ILLINOIS FED. AID PROJECT				