

CONTROLLER SEQUENCE

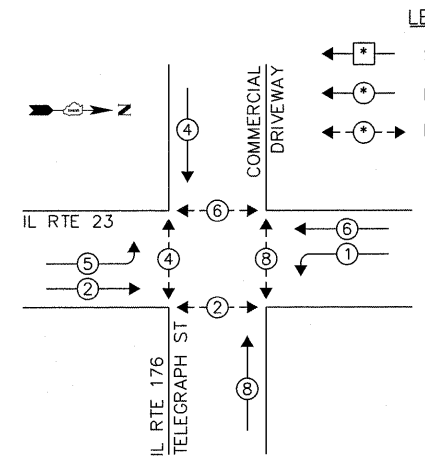

PHASE DESIGNATION DIAGRAM

- LEGEND:
- ◀ * → SINGLE ENTRY PHASE
 - ◀ * → DUAL ENTRY PHASE
 - ◀ * → PEDESTRIAN PHASE

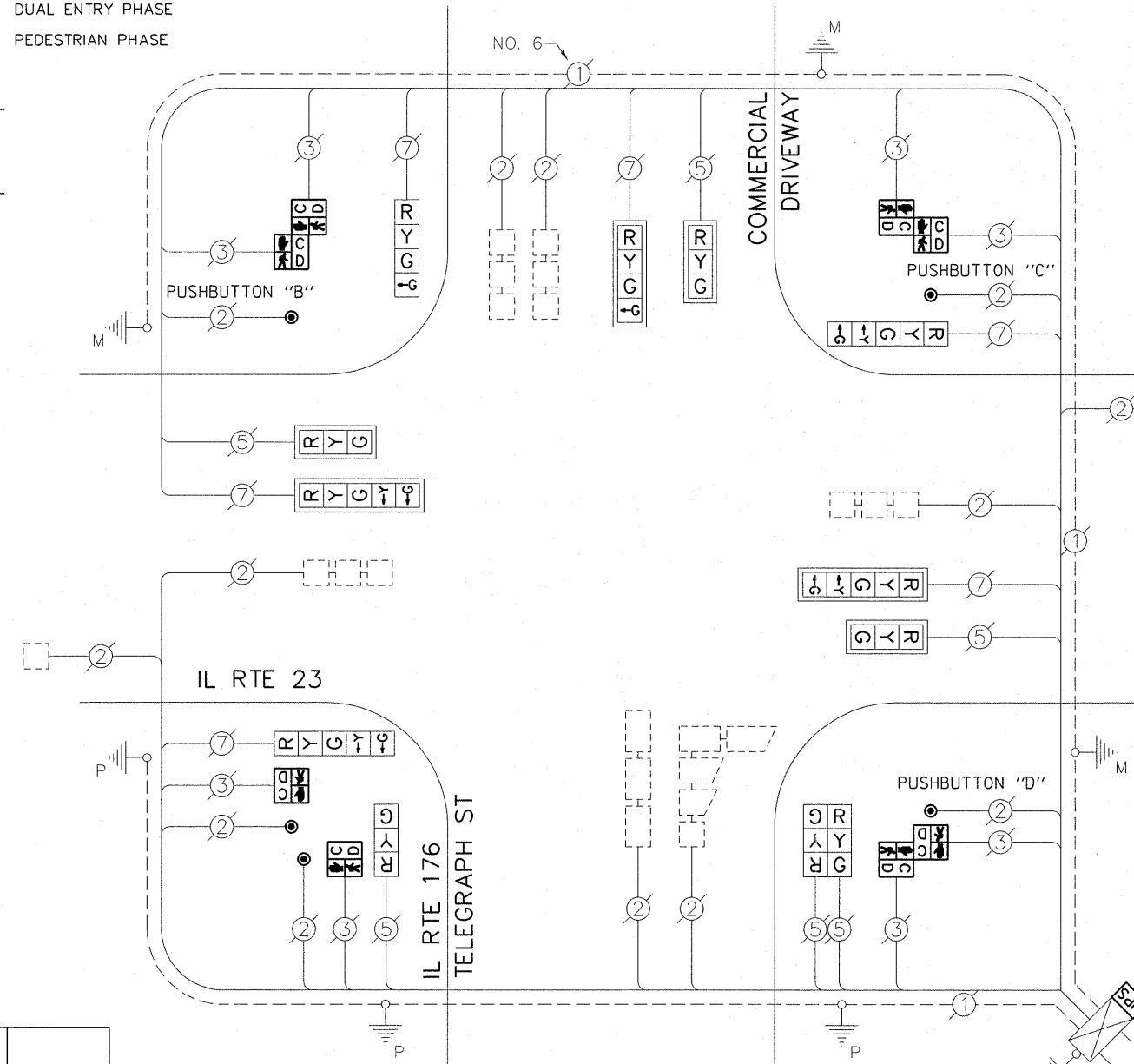

CABLE PLAN

NOTE:
 PUSHBUTTON "B" SHALL PLACE A CALL IN PHASES 4 AND 6
 PUSHBUTTON "C" SHALL PLACE A CALL IN PHASES 6 AND 8
 PUSHBUTTON "D" SHALL PLACE A CALL IN PHASES 2 AND 8



THE FOLLOWING ITEMS SHALL BE REMOVED BY THE CONTRACTOR AND SHALL BE DISPOSED OF BY THEM OUTSIDE THE RIGHT-OF-WAY AT THEIR EXPENSE. THE SALVAGE VALUE OF THE REMOVED EQUIPMENT SHALL BE REFLECTED IN THE CONTRACT BID PRICE.

- 8 EACH PEDESTRIAN SIGNAL HEAD
- 5 EACH PEDESTRIAN PUSH-BUTTON

RETROFIT ALL EXISTING TRAFFIC SIGNAL HEADS TO L.E.D.

I.D.O.T. TRAFFIC SIGNAL INSTALLATION ELECTRICAL SERVICE REQUIREMENTS					TOTAL WATTAGE
TYPE	NO. OF LAMPS	WATTAGE		% OPERATION	
SIGNAL (RED)	12	INCAND.	17	0.50	102.00
(YELLOW)	12		25	0.25	75.00
(GREEN)	14		15	0.25	52.50
ARROW	8		12	0.10	9.60
PED. SIGNAL	8		25	1.00	200.00
CONTROLLER	1		100	1.00	100.00
ILLUM. SIGN	-		25	0.05	-
VIDEO SYSTEM	-		-	1.00	-
FLASHER				0.50	
ENERGY COSTS TO:				TOTAL =	539.10

CITY OF MARENGO
 132 EAST PRAIRIE STREET
 MARENGO, IL 60152
 ENERGY SUPPLY: CONTACT: MIKE LENOX
 PHONE: (815) 490-2869
 COMPANY: COMMONWEALTH EDISON

ITEM	UNIT	QUANTITY
MAINTENANCE OF EXISTING TRAFFIC SIGNAL INSTALLATION	EACH	1
PEDESTRIAN SIGNAL HEAD, LED, 1-FACE, BM WITH COUNTDOWN TIMER	EACH	2
PEDESTRIAN SIGNAL HEAD, LED, 2-FACE, BM WITH COUNTDOWN TIMER	EACH	3
MODIFY EXISTING CONTROLLER CABINET	EACH	1
REMOVE EXISTING TRAFFIC SIGNAL EQUIPMENT	EACH	1
SIGNAL HEAD, LED, 1-FACE, 3-SECTION, BM, RETROFIT	EACH	1
SIGNAL HEAD, LED, 1-FACE, 3-SECTION, MAM, RETROFIT	EACH	3
SIGNAL HEAD, LED, 1-FACE, 5-SECTION, MAM, RETROFIT	EACH	2
SIGNAL HEAD, LED, 2-FACE, 3-SECTION, BM, RETROFIT	EACH	1
PEDESTRIAN PUSH-BUTTON, NON-LATCHING	EACH	5
SIGNAL HEAD, LED, 1-FACE, 4-SECTION, BM, RETROFIT	EACH	1
SIGNAL HEAD, LED, 1-FACE, 4-SECTION, MAM, RETROFIT	EACH	1
SIGNAL HEAD, LED, 1-FACE, 5-SECTION, BM, RETROFIT	EACH	2
UNINTERRUPTIBLE POWER SUPPLY SPECIAL	EACH	1