

SEGMENTAL CONCRETE BLOCK WALL, SPECIAL DETAIL

NO SCALE
ORCHARD DRIVE, SEE PLANS FOR LOCATION

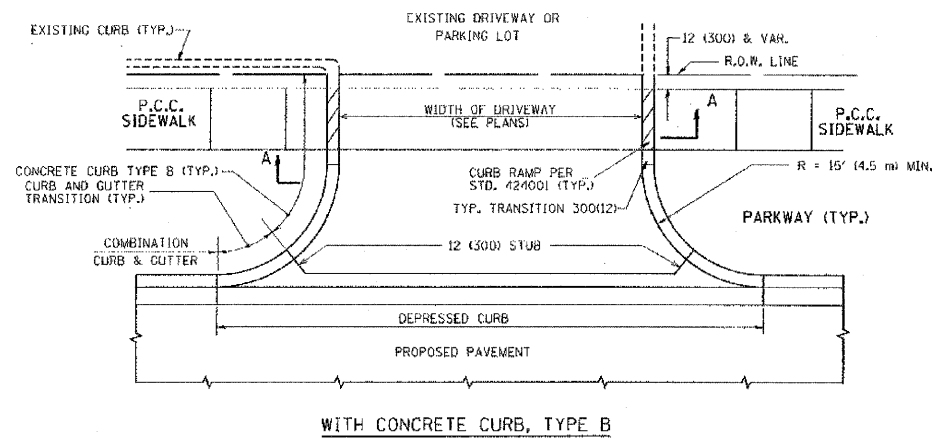

WITH CONCRETE CURB, TYPE B

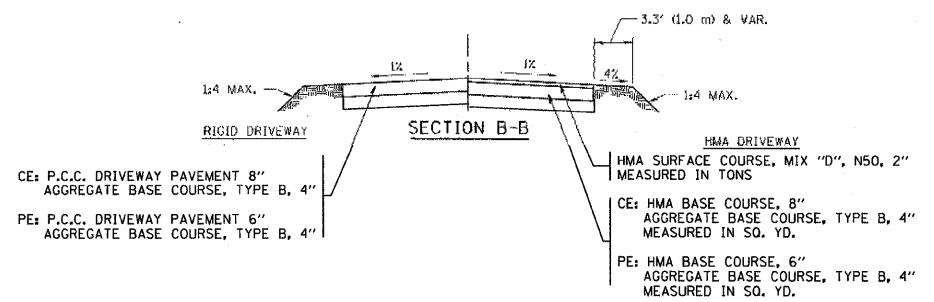
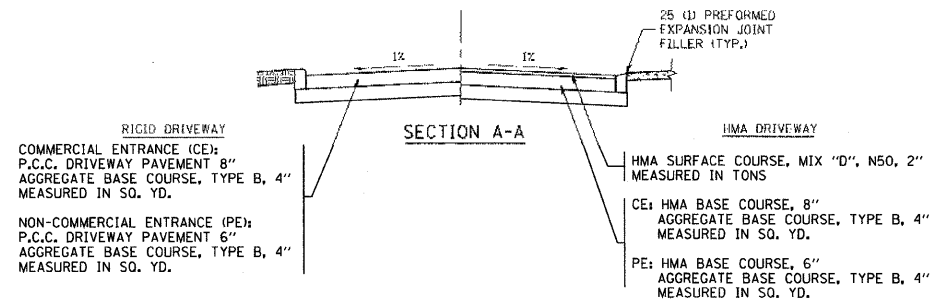

DRIVEWAY DETAILS

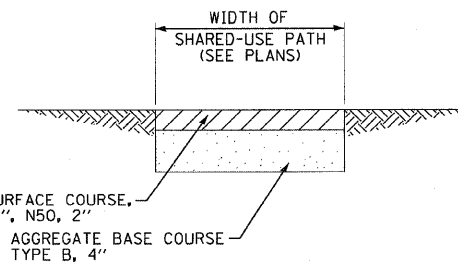

SHARED-USE PATH DETAIL

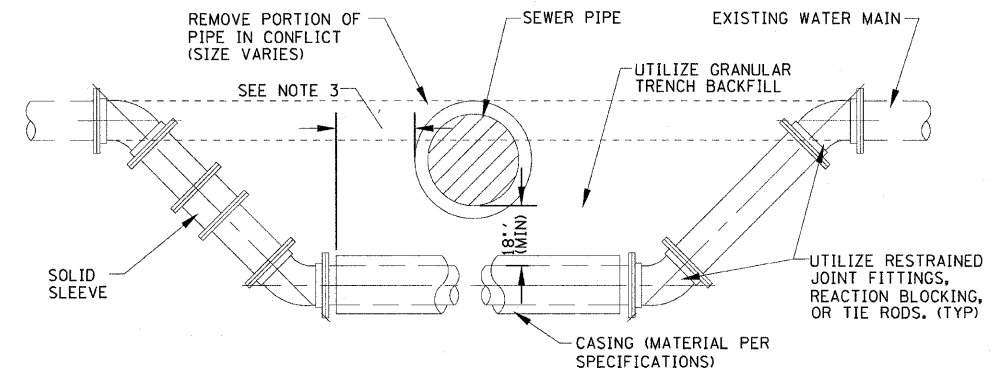

- NOTE:**
1. WATER MAIN RELOCATIONS ARE SUBJECT TO INSPECTION AT NORMAL SYSTEM PRESSURE BEFORE BURIAL.
 2. USE ONLY 45 DEGREE BENDS UNLESS OTHERWISE PERMITTED BY THE ENGINEER.
 3. CASING MUST EXTEND A MINIMUM OF 10 FEET BEYOND OUTSIDE EDGE OF SEWER PIPE - ON BOTH SIDES OF SEWER.

ADJUSTING WATER MAIN - DUCTILE IRON

NO SCALE

GENERAL NOTES:

DRIVEWAY SLOPES, LOCATIONS, & GEOMETRIC LAYOUT SHALL BE IN ACCORDANCE WITH THE LATEST EDITION OF THE "HANDBOOK FOR POLICY ON PERMITS FOR ACCESS DRIVEWAYS TO STATE HIGHWAYS". FOR FURTHER LAYOUT REQUIREMENTS, REFER TO ILLUSTRATIONS IN THE PERMIT HANDBOOK. DRIVEWAYS SHALL BE REPLACED IN KIND, UNLESS OTHERWISE NOTED ON THE PLANS.

COMMERCIAL DRIVEWAYS SHALL BE CONSTRUCTED WITH CONCRETE CURB, TYPE B RETURNS.

COMBINATION CONCRETE CURB AND GUTTER SHALL BE MEASURED STRAIGHT ACROSS THE DRIVEWAY. NO ADDITIONAL COMPENSATION WILL BE ALLOWED FOR THE CURB AND GUTTER TRANSITION.

1" (25) PREFORMED EXPANSION JOINT FILLER WILL NOT BE PAID SEPARATELY, BUT SHALL BE CONSIDERED INCLUDED IN THE COST OF THE P.C.C. DRIVEWAY PAVEMENT OR P.C.C. SIDEWALK.

WHEN THE P.C.C. SIDEWALK EXTENDS THROUGH THE DRIVEWAY, THE THICKNESS OF THE SIDEWALK IN THE DRIVEWAY AREA SHALL BE THE SAME AS THE DRIVEWAY THICKNESS. SIDEWALK WILL BE PAID FOR AS P.C.C. SIDEWALK OF THE THICKNESS SPECIFIED. SIDEWALK CROSS SLOPE THRU DRIVEWAY AREA TO BE A MAXIMUM OF 1:50.

CONTRACT © 2011 BY BATES & WOODMAN, INC.
 LICENSE NO. 184-C0131 - EXPIRES 4/30/2013
 IN: Crystal Lake, IL 60010
 815-408-2200



DESIGNED - TAO	REVISED -
DRAWN - KAR	REVISED -
CHECKED - TAO	REVISED -
DATE - 10/31/11	FILE - 060670-PH2-Misc-De'ts.sht

**STATE OF ILLINOIS
ORCHARD DRIVE IMPROVEMENTS**

MISCELLANEOUS DETAILS

SCALE: NONE

STA. TO STA.

F.A.U. RTE.	SECTION	COUNTY	TOTAL SHEETS	SHEET NO.
2836	06-00090-00-FP	COOK	200	161
CONTRACT NO. 63635				
FED. ROAD DIST. NO. 1 ILLINOIS FED. AID PROJECT M-80031661				