

When cantilever forming brackets are used, the work shall be done according to Article 503.06(b) of the Standard Specifications, except as modified below and in the details shown on this sheet.

The finishing machine rails shall be placed on the top flange of the exterior beams.

The beams or girders, supporting cantilever forming brackets, shall be tied together at 4 foot intervals.

For Standard construction, or Stage Construction the Hardwood bracing materials shall be placed as shown between webs of beams in each bay.

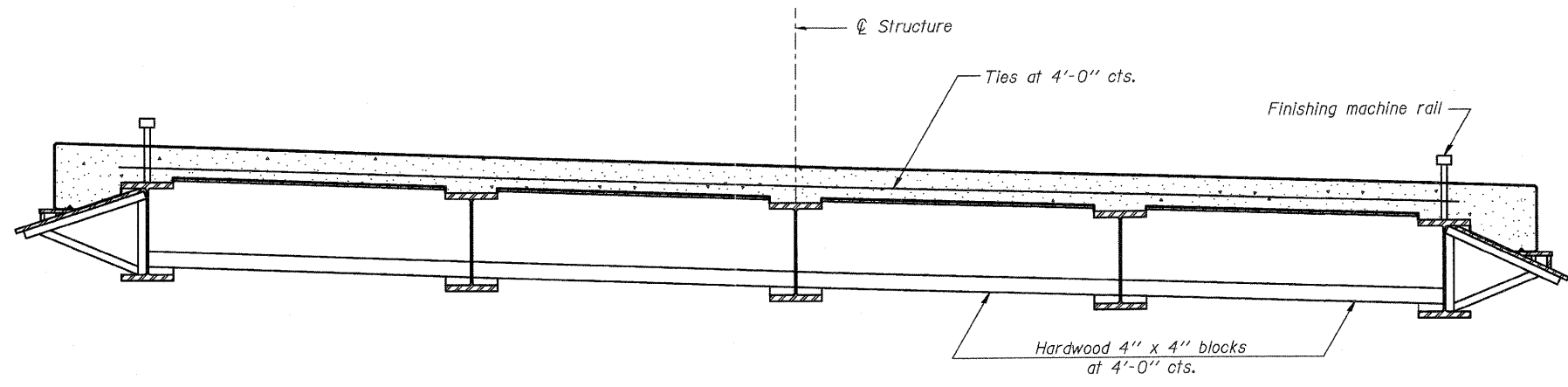

**FORM BRACES FOR
STANDARD CONSTRUCTION**

FILE NAME = W:\Projects\2010\100025 BurrFerson\1\cadd\Structural\09m\0453080-019-Cantilever.dgn

WBK WILLS BURKE KELSEY ASSOCIATES LTD.
116 West Main Street, Suite 201
St. Charles, Illinois 60174

USER NAME = nparris	DESIGNED - HLF	REVISED -
	CHECKED - AEU	REVISED -
PLOT SCALE =	DRAWN - HLF	REVISED -
PLOT DATE = 10/18/2011	CHECKED - AEU	REVISED -

**STATE OF ILLINOIS
DEPARTMENT OF TRANSPORTATION**

**CANTILEVER FORMING BRACKETS
STRUCTURE NO. 045-3080**

SHEET NO. 19 OF 20 SHEETS

I.R. RTE.	SECTION	COUNTY	TOTAL SHEETS	SHEET NO.
0194	08-14117-00-BR	KANE	76	52
FED. ROAD DIST. NO.			ILLINOIS FED. AID PROJECT	
CONTRACT NO. 63645				