

DETAIL A

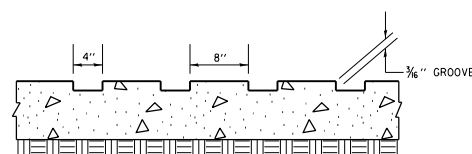

SECTION A-A

RUMBLE RESURFACING DETAIL

- NOTES:
1. ALL GROOVES SHALL BE CONSTRUCTED USING A 4" (100 mm) MILLING HEAD OR SERIES OF 4" (100 mm) MILLING HEADS CAPABLE OF CUTTING TO THE SPECIFIED DEPTH OR ANY VARIABLE DEPTH.
  2. THIS WORK WILL BE MEASURED FOR PAYMENT PER EACH 25' (7.6 m) INDIVIDUAL RUMBLE STRIP APPLIED AND PAID FOR AT THE CONTRACT UNIT PRICE EACH FOR RUMBLE STRIP, WHICH PRICE SHALL INCLUDE ALL EQUIPMENT, MATERIAL, LABOR AND OTHER ITEMS REQUIRED TO INSTALL EACH INDIVIDUAL RUMBLE STRIP.

DRAW BRIDGE UP WHEN FLASHING

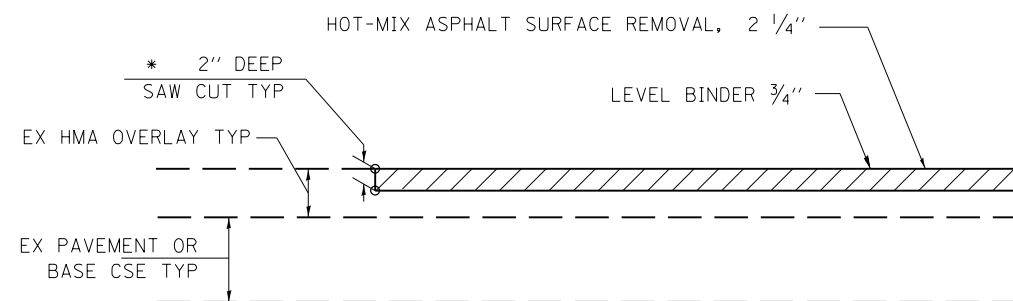

\* SAW CUT IS INCLUDED IN THE COST OF HMA SURFACE REMOVAL 2 1/4" AND IS NOT TO BE PAID SEPARATELY.

BUTT JOINT DETAIL

FILE NAME = c:\pwork\pwork\pwork\sparksgw\0222140\0672078-sht-details.dgn	USER NAME = sparksgw	DESIGNED - DMS	REVISED -	<b>STATE OF ILLINOIS DEPARTMENT OF TRANSPORTATION</b>	<b>PROJECT DETAILS</b>				F.A.P. RTE.	SECTION	COUNTY	TOTAL SHEETS	SHEET NO.
	PLOT SCALE = 100.0000' / 1in.	DRAWN - DMS	REVISED -						757	20RS-7	PIKE	39	36
PLOT DATE = Oct-20-2011 03:20:36PM	CHECKED -	REVISIED -	REVISIED -	SCALE:	SHEET NO.	OF SHEETS	STA.	TO STA.	CONTRACT NO. 72D78				
	DATE -	REVISIED -	REVISIED -	ILLINOIS FED. AID PROJECT									