

**MAIN DECK PLAN**  
SCALE: 1/4" = 1'-0"

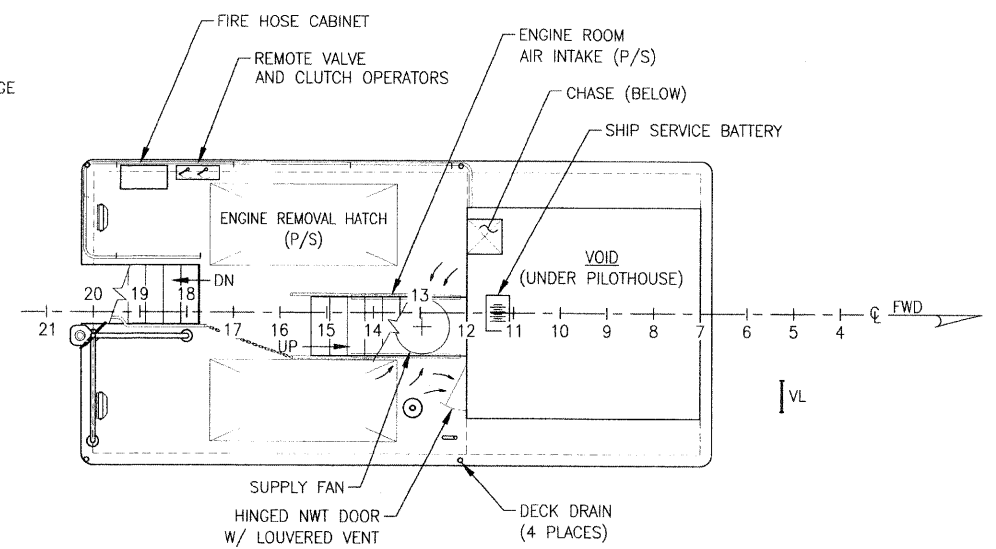

**UPPER DECK PLAN**  
SCALE: 1/4" = 1'-0"

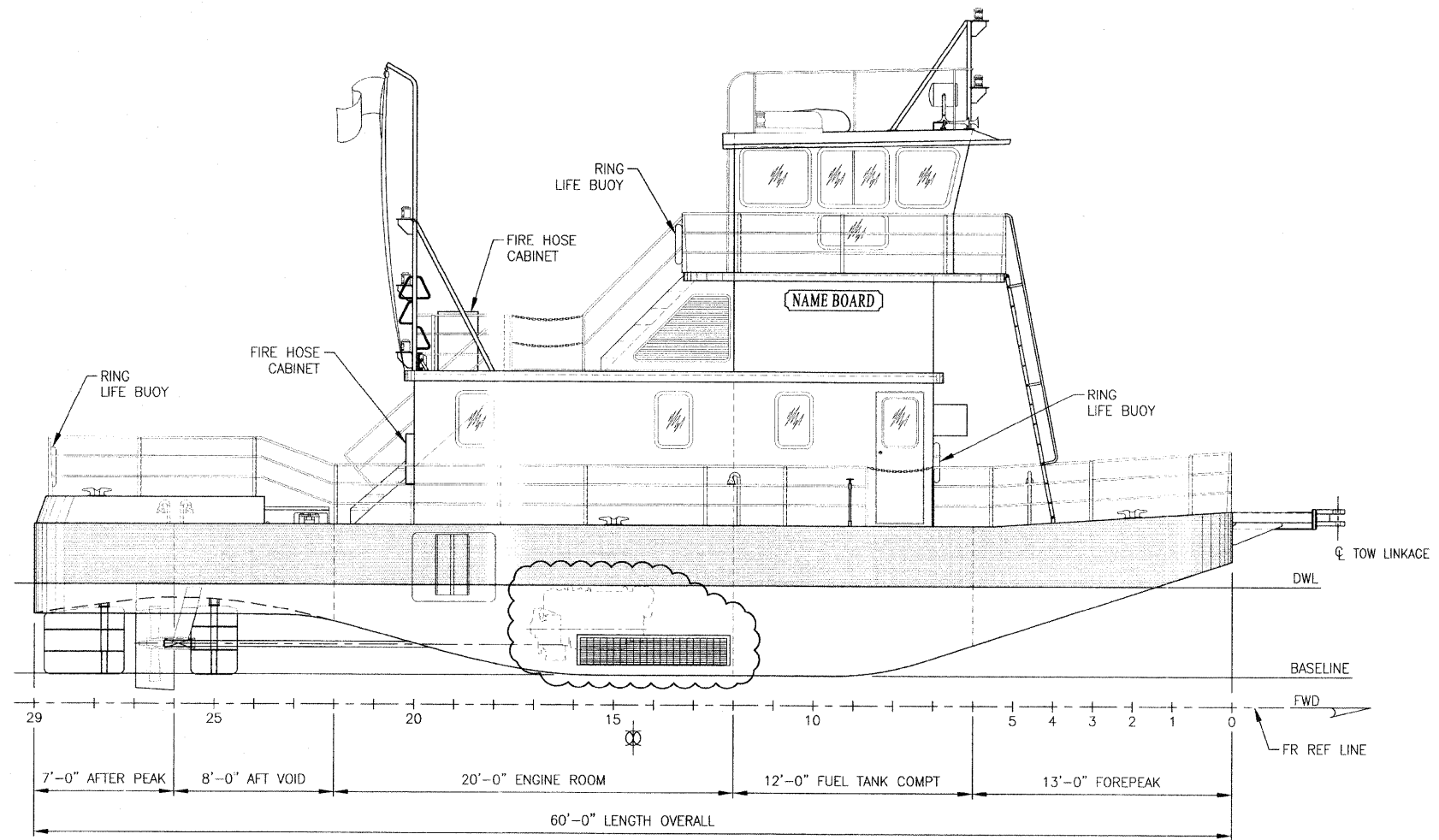

**STARBOARD PROFILE**  
SCALE: 1/4" = 1'-0"

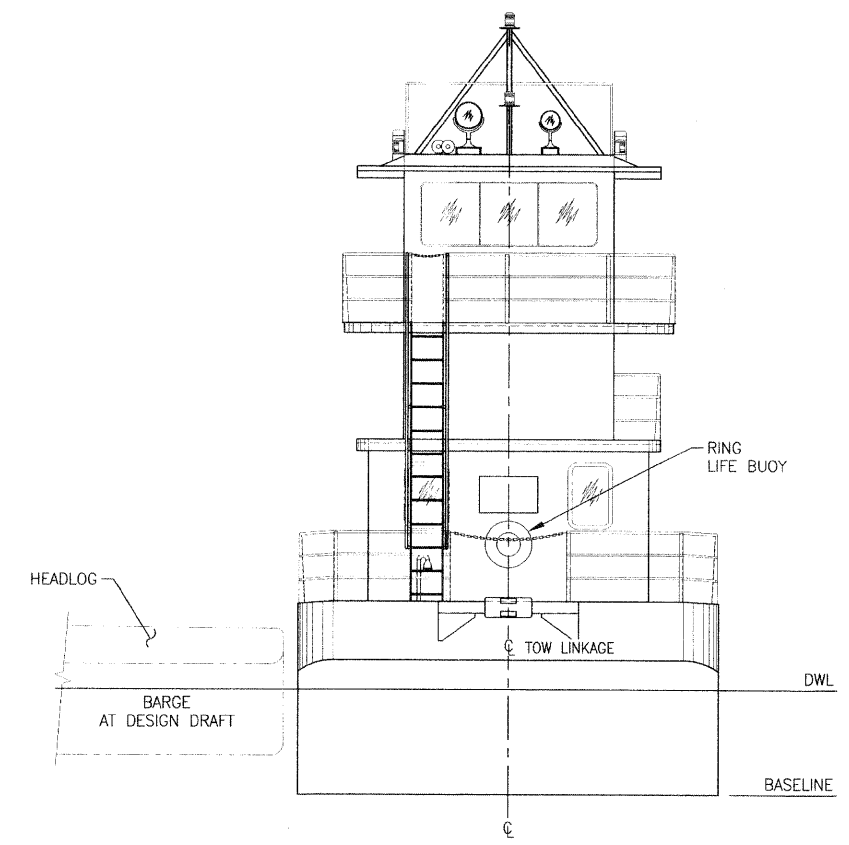

**BOW ELEVATION**  
SCALE: 1/4" = 1'-0"

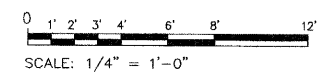

**ART ANDERSON ASSOCIATES**  
202 PACIFIC AVE., BREMERTON, WA 98537  
(360) 479-2600

**BID ALT 1**

FILE NAME =	USER NAME =	DESIGNED -- A. WINKLEY	REVISED --
		DRAWN -- J. WALKER	REVISED --
		CHECKED -- P. MARTIN	REVISED --
		DATE -- 7/26/2011	REVISED --

**STATE OF ILLINOIS  
DEPARTMENT OF TRANSPORTATION**

**IDOT BRUSSELS FERRY - BID ALTERNATE  
GENERAL ARRANGEMENT - PUSHBOAT**

SCALE: AS SHOWN	SHEET NO. OF SHEETS	STA. TO STA.
-----------------	---------------------	--------------

F.A.P. RTE. 304	SECTION 21-3	COUNTY JERSEY	TOTAL SHEETS 47	SHEET NO. 1
CONTRACT NO. 76D29			FED. ROAD DIST. NO. ILLINOIS FED. AID PROJECT	