

F.A. RTE.	SECTION	COUNTY	TOTAL SHEETS	SHEET NO.
64/44	2003-03-11	COOK	476	398
STA.	TO STA.			
FED. ROAD DIST. NO.	ILLINOIS	FED. AID PROJECT		

62583

- NOTES:
1. ALL DIMENSIONS ARE IN MILLIMETERS (INCHES) UNLESS OTHERWISE SHOWN.
 2. THE ANCHOR BOLTS AND RACEWAYS SHALL BE PROPERLY SECURED IN PLACE BEFORE THE CONCRETE IS PLACED IN THE FORMS.
 3. THE CONTRACTOR AT HIS OPTION MAY SUBSTITUTE 15 m (#4) TIES AT 304.8 m (12") CTRS. FOR THE 3 m (#3) SPIRAL. TACKWELDED TYPE BOLT MAY BE SUBSTITUTED FOR THE HOOK TYPE BOLT.
 4. COLD BENDING OF THE HOOK BOLT SHALL NOT BE ALLOWED.
 5. EXCAVATION FOR THE POLE FOUNDATION SHALL BE MADE WITH AN AUGER 609.6 m (24 INCHES) IN DIAMETER.
 6. THE ENGINEER SHALL DETERMINE THE TYPE OF SOIL DURING EXCAVATION AND SELECT THE DESIGN DEPTH OF FOUNDATION FROM THE DESIGN TABLE USING THE DOMINANT CHARACTERISTIC OF THE SOIL ENCOUNTERED.
 7. BARRIER WALL EXPANSION AND CONSTRUCTION JOINTS SHALL BE IN ACCORDANCE WITH STANDARD DETAIL 637001-02 AND 637006 AS APPLICABLE.

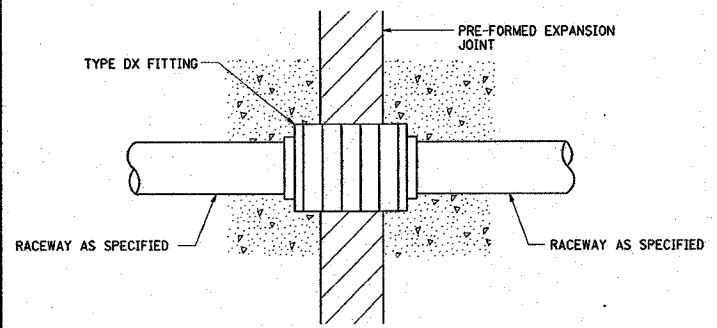
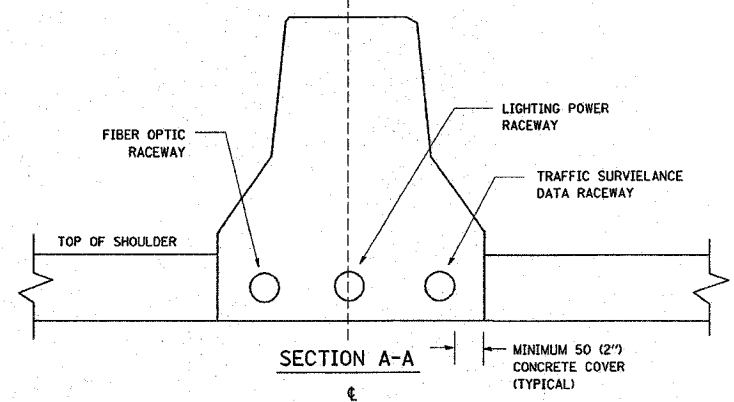
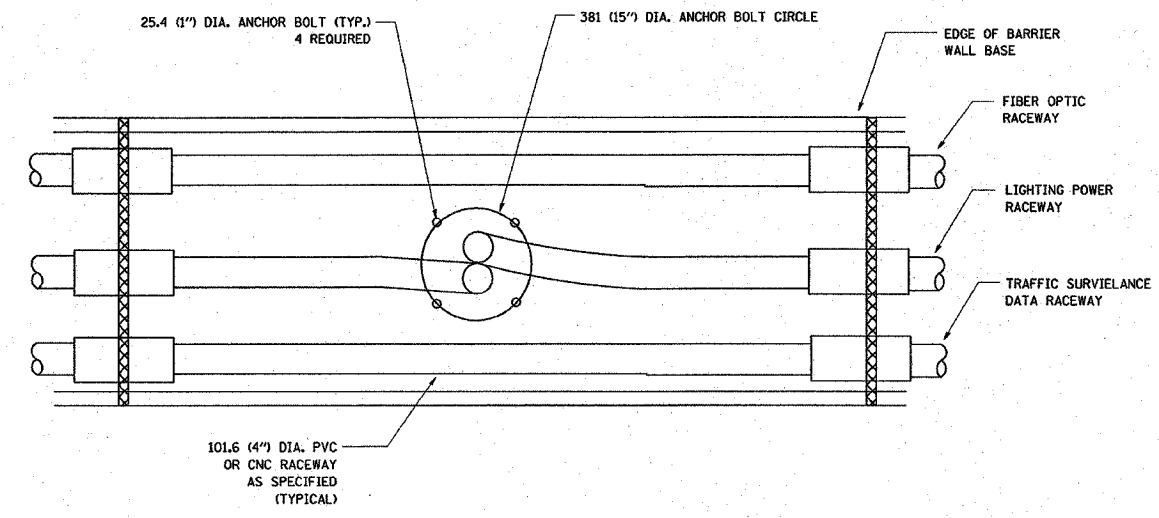

CONDUIT DEFLECTION FITTING DETAIL

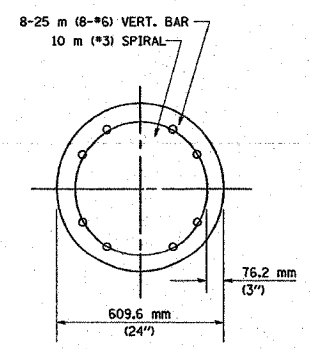
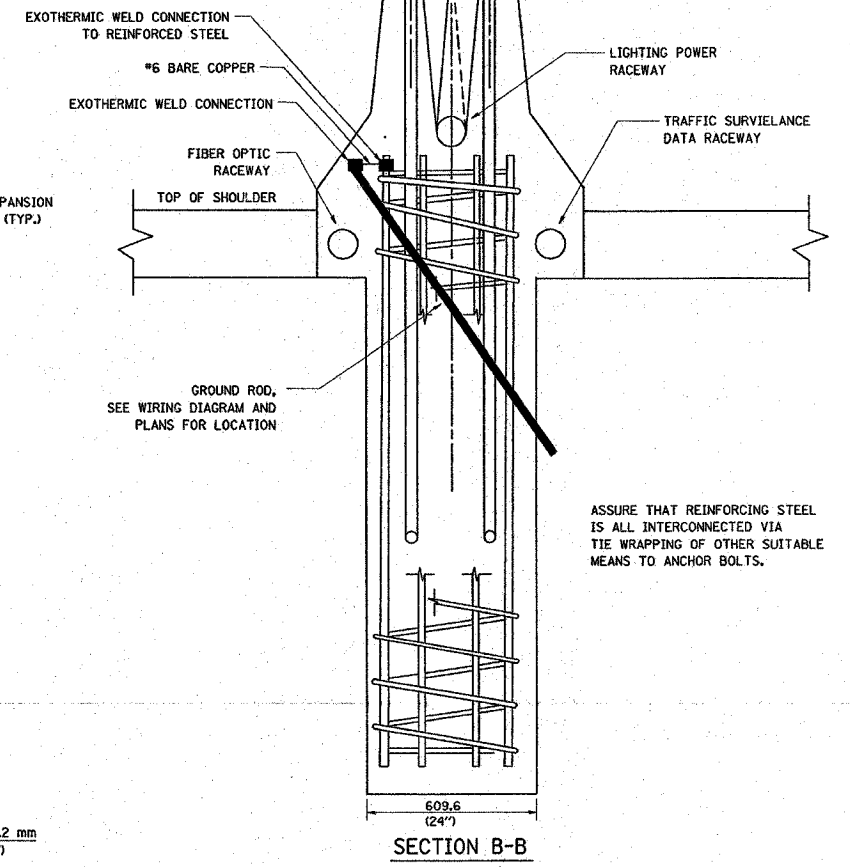
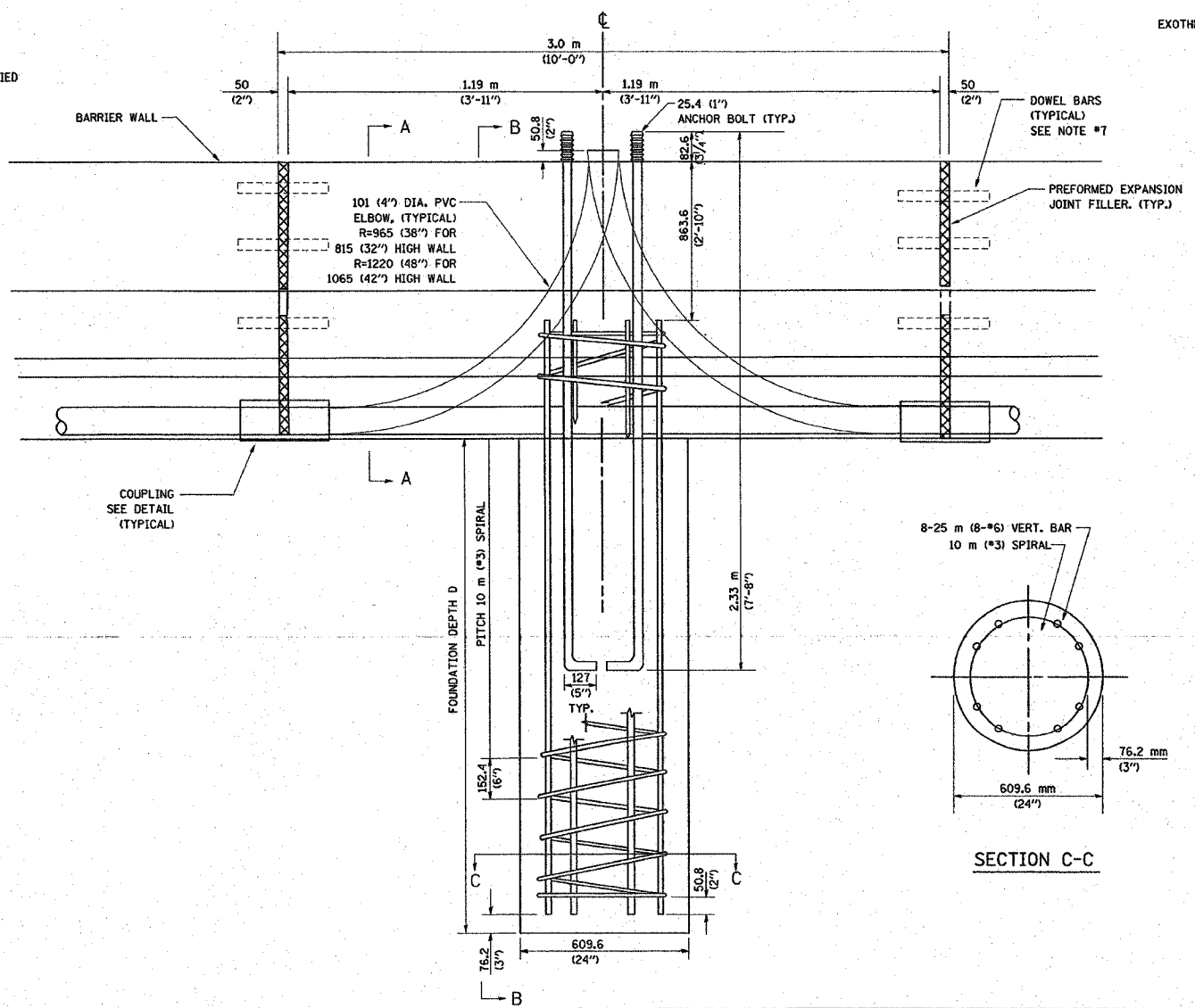

SECTION C-C

TYPE OF SOIL	FOUND FEPTH D	REINFORCEMENT IN FOUNDATION	
		VERTICAL BARS	SPIRAL
ROCK OR SOLIDIFIED SLAG	1.52 m (5'-0")	NONE	NONE
DENSE SAND	2.36 m (7'-9")	8-20 m x 2.74 m (8-#6 x 9'-0")	3 m x 27.43 m (#3 x 90')
MEDIUM SAND	2.51 m (8'-3")	8-20 m x 2.87 m (8-#6 x 9'-5")	3 m x 28.65 m (#3 x 94')
LOOSE SAND	2.74 m (9'-0")	8-20 m x 3.09 m (8-#6 x 10'-2")	3 m x 30.48 m (#3 x 100')
STIFF CLAY	2.13 m (7'-0")	8-20 m x 2.48 m (8-#6 x 8'-0")	3 m x 24.38 m (#3 x 80')
MEDIUM CLAY	2.89 m (9'-6")	8-20 m x 3.25 m (8-#6 x 10'-8")	3 m x 31.69 m (#3 x 104')
SOFT CLAY	3.96 m (13'-0")	8-20 m x 4.32 m (8-#6 x 14'-2")	3 m x 43.89 m (#3 x 144')

DESIGN: 80 MPH AASHTO

REVISIONS	
NAME	DATE

ILLINOIS DEPARTMENT OF TRANSPORTATION
 609.6 mm (24") DIA. LIGHT POLE FOUNDATION INTEGRAL WITH DOUBLE FACE BARRIER WALL
 SCALE: VERT. NONE
 HORIZ. NONE
 DATE 04/07/2004
 DRAWN BY CADD
 CHECKED BY

BE-322

BE-322

06:52:46 04/07/2004

04/07/2004
 c:\projects\view\electrical\2003\stgrt\stgrt.dgn