

S.A. NO.	SECTION	COUNTY	TOTAL SHEETS	SHEET NO.
10/44	2003-031 I	COOK	976	403
STA.	TO STA.			
FED. ROAD DIST. NO. 7	ILLINOIS	FED. AID PROJECT		

62583

**LIGHT TOWER FOUNDATION DEPTH "D"**

MOUNTING HEIGHT	SOIL CONDITIONS					
	SOFT CLAY Qu = 0.375 TON/SQ. FT	MEDIUM CLAY Qu = 0.75 TON/SQ. FT	STIFF CLAY Qu = 1.50 TON/SQ. FT	LOOSE SAND φ = 34°	MEDIUM SAND φ = 37.5°	DENSE SAND φ = 40°
27m (90 ft)	8.779m (29 ft)	6.035m (20 ft)	4.389m (15 ft)	4.389m (15 ft)	3.840m (13 ft)	3.429m (12 ft)
30m (100 ft)	9.754m (32 ft)	6.706m (22 ft)	4.877m (16 ft)	4.877m (16 ft)	4.267m (14 ft)	3.81m (13 ft)
33m (110 ft)	10.719m (35 ft)	7.377m (24 ft)	5.365m (18 ft)	5.365m (18 ft)	4.694m (15 ft)	4.191m (14 ft)
36m (120 ft)	11.705m (38 ft)	8.046m (26 ft)	5.652m (19 ft)	5.652m (19 ft)	5.120m (17 ft)	4.572m (16 ft)

**DESIGN NOTES**

- (1) ALL DIMENSIONS IN MILLIMETERS (INCHES) UNLESS OTHERWISE SHOWN
- (2) THE HOLE FOR THE FOUNDATION SHALL BE ACCORDING
- (3) THE ANCHOR BOLTS SHALL BE VERTICAL NO ADJUSTMENT SHALL BE ALLOWED AFTER THE FOUNDATION IS PLACED.
- (4) THE GAP BETWEEN THE FOUNDATION AND THE BASE PLATE SHALL BE ENCLOSED WITH A STAINLESS STEEL SCREEN FASTENED WITH A STAINLESS STEEL BAND.
- (5) THE TOP OF THE FOUNDATION TO 450 (18") BELOW GRADE SHALL BE FORMED.
- (6) A CONCRETE WORK PAD SHALL BE PROVIDED AS INDICATED IN THE PLANS AS A PART OF THIS ITEM.
- (7) SURFACE WATER WILL NOT BE PERMITTED TO ENTER THE HOLE AND ALL WATER WHICH MAY HAVE INFILTRATED INTO THE HOLE SHALL BE REMOVED BEFORE PLACING CONCRETE.
- (8) THE LIGHT TOWER SHALL NOT BE ERECTED UNTIL AFTER THE CONCRETE HAS BEEN CURED ACCORDING TO ARTICLE 1020.13.
- (9) ANCHOR RODS SHALL BE STRAIGHT AND SHALL BE ACCORDING TO AASHTO M 314 OR ASTM F1554, GRADE 725(GRADE 105) AND GALVANIZED ACCORDING TO ARTICLE 1006.9.
- (10) ANCHOR ROD INFORMATION SHALL BE SUBMITTED FOR APPROVAL AND SHALL BE FULLY COORDINATED FOR APPROVAL WITH TOWER MANUFACTURER REQUIREMENTS.
- (11) REINFORCEMENT BARS SHALL BE ACCORDING TO ARTICLE 1006.10
- (12) TWO ANCHOR RODS OPPOSITE EACH OTHER SHALL HAVE THE ANCHOR ROD THREADS PEENED AFTER NUTS ARE INSTALLED.

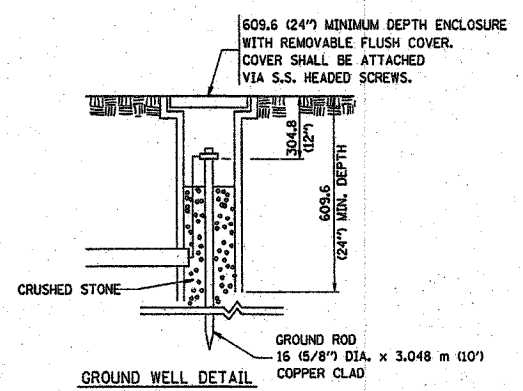
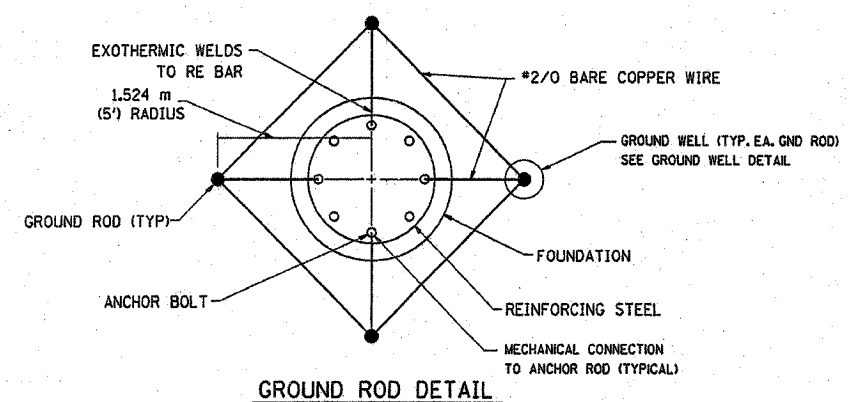
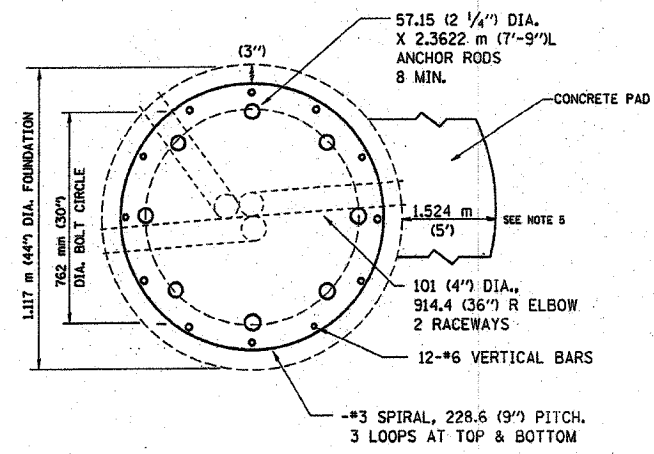
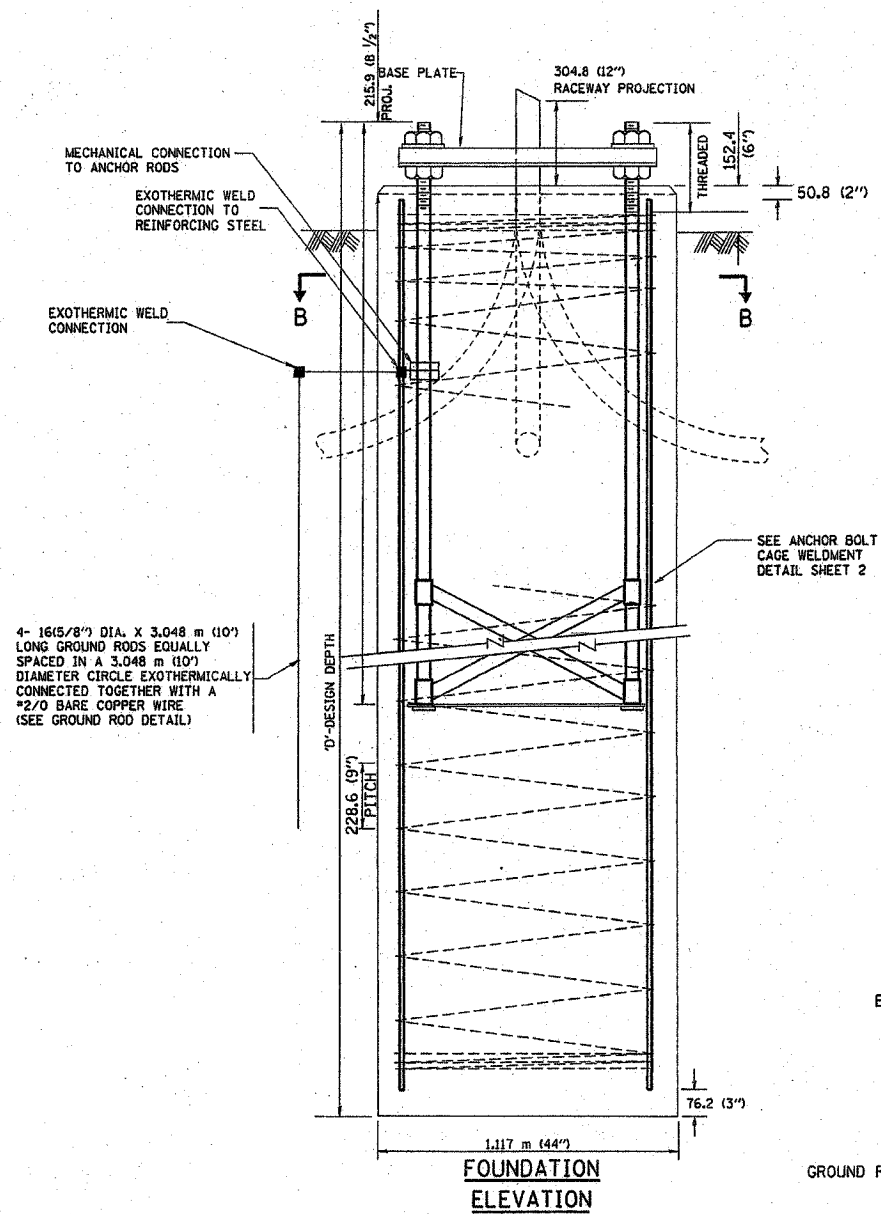

REVISIONS	
NAME	DATE

ILLINOIS DEPARTMENT OF TRANSPORTATION

BE501

HIGH MAST LIGHT TOWER  
27m TO 36m (90FT TO 120FT)  
FOUNDATION DETAIL

SHEET 1 OF 2

SCALE: NONE

DATE 3/22/01

DRAWN BY

CHECKED BY

OLD BE08

BE501