

STATE OF ILLINOIS  
DEPARTMENT OF TRANSPORTATION

|                       |           |                   |              |           |
|-----------------------|-----------|-------------------|--------------|-----------|
| ROUTE NO.             | SECTION   | COUNTY            | TOTAL SHEETS | SHEET NO. |
| F.A.I. RTE. 94/94     | 2003-0311 | COOK              | 976          | 970       |
| FED. ROAD DIST. NO. 1 | ILLINOIS  | FED. AID PROJECT- | 62583        |           |

| POST   | CONCRETE FOUNDATION TABLE |                |                         |                      |                      |                    |                  |           | POST TO STUB POST CONNECTION DATA |        |        |        |        |                |                |      | FUSE PLATE DATA |       |        |        |                |          |
|--------|---------------------------|----------------|-------------------------|----------------------|----------------------|--------------------|------------------|-----------|-----------------------------------|--------|--------|--------|--------|----------------|----------------|------|-----------------|-------|--------|--------|----------------|----------|
|        | Foundation                |                |                         | Reinforcement        |                      |                    | Stub Post Length | Bolt Size | A                                 | B      | C      | D      | E      | t <sub>1</sub> | t <sub>2</sub> | R    | W               | J     | K      | L      | t <sub>3</sub> |          |
|        | Diameter                  | *Minimum Depth | Concrete (cu. yds.) (1) | Vertical Bars Length | Bar Spirals Diameter | Bar Spirals Length |                  |           |                                   |        |        |        |        |                |                |      |                 |       |        |        |                | lbs. (2) |
| W6x9   | 2'-0"                     | 6'-0"          | 0.70                    | 5'-9"                | 1'-8 1/2"            | 79'-0"             | 78               | 2'-3"     | 5/8" x 3/4"                       | 6"     | 2 1/4" | 1 1/4" | 3 1/2" | 1 1/4"         | 3/4"           | 1/2" | 11/32"          | 1/4"  | 4"     | 2 1/4" | 7/8"           | 1/4"     |
| W6x15  | 2'-0"                     | 6'-0"          | 0.70                    | 5'-9"                | 1'-8 1/2"            | 79'-0"             | 78               | 2'-6"     | 5/8" x 3/4"                       | 6"     | 2 1/4" | 1 1/4" | 3 1/2" | 1 1/4"         | 3/4"           | 1/2" | 11/32"          | 1/4"  | 6"     | 3 1/2" | 1 1/4"         | 3/8"     |
| W8x18  | 2'-0"                     | 6'-0"          | 0.70                    | 5'-9"                | 1'-8 1/2"            | 79'-0"             | 78               | 2'-6"     | 3/4" x 3/4"                       | 6"     | 2 1/2" | 1 3/8" | 3 1/4" | 1 3/8"         | 1"             | 1/2" | 11/32"          | 5/16" | 5 1/4" | 2 3/4" | 1 1/4"         | 3/8"     |
| W10x22 | 2'-6"                     | 6'-6"          | 1.18                    | 6'-3"                | 2'-2 1/2"            | 105'-0"            | 92               | 3'-0"     | 3/4" x 3/4"                       | 6"     | 2 1/2" | 1 3/8" | 3 1/4" | 1 3/8"         | 1"             | 1/2" | 11/32"          | 5/16" | 5 3/4" | 2 3/4" | 1 1/2"         | 1/2"     |
| W10x26 | 2'-6"                     | 7'-0"          | 1.27                    | 6'-9"                | 2'-2 1/2"            | 112'-0"            | 98               | 3'-0"     | 7/8" x 4"                         | 7"     | 2 3/4" | 1 1/2" | 4"     | 1 1/2"         | 1"             | 3/4" | 5/32"           | 3/8"  | 5 3/4" | 2 3/4" | 1 1/2"         | 5/8"     |
| W12x26 | 2'-6"                     | 7'-9"          | 1.41                    | 7'-6"                | 2'-2 1/2"            | 119'-0"            | 107              | 3'-0"     | 7/8" x 4"                         | 7"     | 2 3/4" | 1 1/2" | 4"     | 1 1/2"         | 1"             | 3/4" | 5/32"           | 3/8"  | 6 1/2" | 3 1/2" | 1 1/2"         | 5/8"     |
| W14x30 | 3'-0"                     | 7'-3"          | 1.90                    | 7'-0"                | 2'-8 1/2"            | 145'-0"            | 113              | 3'-0"     | 7/8" x 4"                         | 7"     | 2 3/4" | 1 1/2" | 4"     | 1 1/2"         | 1"             | 3/4" | 5/32"           | 3/8"  | 6 3/4" | 3 1/2" | 1 1/2"         | 5/8"     |
| W14x38 | 3'-0"                     | 8'-0"          | 2.09                    | 7'-9"                | 2'-8 1/2"            | 153'-0"            | 122              | 3'-6"     | 1" x 4 1/2"                       | 7 1/2" | 3"     | 1 3/4" | 4"     | 1 3/4"         | 1 1/4"         | 3/4" | 17/32"          | 3/8"  | 6 3/4" | 3 1/2" | 1 5/8"         | 1/2"     |
| W16x45 | 3'-0"                     | 8'-6"          | 2.23                    | 8'-3"                | 2'-8 1/2"            | 162'-0"            | 130              | 3'-6"     | 1" x 4 1/2"                       | 7 1/2" | 3"     | 1 3/4" | 4"     | 1 3/4"         | 1 1/4"         | 3/4" | 17/32"          | 3/8"  | 7"     | 3 1/2" | 1 3/4"         | 1/2"     |

\*Dimensional changes required for varying site conditions shall be approved by the Engineer.

| POST   | FUSE PLATE BOLT SIZE |               |               |               |               |               |               |               |               |               |               |               |               |
|--------|----------------------|---------------|---------------|---------------|---------------|---------------|---------------|---------------|---------------|---------------|---------------|---------------|---------------|
|        | Sign Depth           |               |               |               |               |               |               |               |               |               |               |               |               |
|        | 4'-0"                | 5'-0"         | 6'-0"         | 7'-0"         | 8'-0"         | 9'-0"         | 10'-0"        | 11'-0"        | 12'-0"        | 13'-0"        | 14'-0"        | 15'-0"        | 16'-0"        |
| W6x9   | 1/2" x 1 1/2"        | 1/2" x 1 1/2" | 1/2" x 1 1/2" | 5/8" x 1 3/4" | 5/8" x 1 3/4" | 5/8" x 1 3/4" | ---           | ---           | ---           | ---           | ---           | ---           | ---           |
| W6x15  | 1/2" x 1 3/4"        | 1/2" x 1 3/4" | 5/8" x 2"     | 5/8" x 2"     | 3/4" x 2"     | 3/4" x 2"     | 3/4" x 2"     | 3/4" x 2"     | 7/8" x 2"     | 7/8" x 2"     | ---           | ---           | ---           |
| W8x18  | 1/2" x 1 3/4"        | 1/2" x 1 3/4" | 1/2" x 1 3/4" | 5/8" x 2"     | 5/8" x 2"     | 3/4" x 2"     | 3/4" x 2"     | 7/8" x 2 1/4" | 7/8" x 2 1/4" | 7/8" x 2 1/4" | 7/8" x 2 1/4" | 7/8" x 2 1/4" | 7/8" x 2 1/4" |
| W10x22 | 1/2" x 2"            | 1/2" x 2"     | 1/2" x 2"     | 5/8" x 2"     | 5/8" x 2"     | 3/4" x 2 1/4" | 3/4" x 2 1/4" | 7/8" x 2 1/4" | 7/8" x 2 1/4" | 7/8" x 2 1/4" | 1" x 2 1/2"   | 1" x 2 3/4"   | 1" x 2 3/4"   |
| W10x26 | 1/2" x 2"            | 1/2" x 2"     | 1/2" x 2"     | 5/8" x 2 1/4" | 5/8" x 2 1/4" | 3/4" x 2 1/2" | 3/4" x 2 1/2" | 7/8" x 2 1/2" | 7/8" x 2 1/2" | 1" x 2 3/4"   | 1" x 2 3/4"   | 1" x 2 3/4"   | 1 1/8" x 3"   |
| W12x26 | ---                  | ---           | ---           | ---           | ---           | 5/8" x 2 1/4" | ---           | ---           | 7/8" x 2 1/2" | 7/8" x 2 1/2" | 1" x 2 1/2"   | 1" x 2 3/4"   | 1" x 2 3/4"   |
| W14x30 | 1/2" x 2"            | 1/2" x 2"     | 1/2" x 2"     | 1/2" x 2"     | 1/2" x 2"     | 5/8" x 2"     | 3/4" x 2 1/4" | 3/4" x 2 1/4" | 3/4" x 2 1/4" | 7/8" x 2 1/2" | 1" x 2 1/2"   | 1" x 2 3/4"   | 1" x 2 3/4"   |
| W14x38 | ---                  | 1/2" x 2"     | 1/2" x 2"     | 1/2" x 2"     | 1/2" x 2"     | 5/8" x 2 1/4" | 3/4" x 2 1/4" | 3/4" x 2 1/4" | 3/4" x 2 1/2" | 7/8" x 2 1/2" | 7/8" x 2 1/2" | 1" x 2 1/2"   | 1" x 2 3/4"   |
| W16x45 | ---                  | ---           | ---           | 1/2" x 2"     | 1/2" x 2"     | 5/8" x 2 1/4" | 5/8" x 2 1/4" | 3/4" x 2 1/4" | 3/4" x 2 1/2" | 7/8" x 2 1/2" | 7/8" x 2 1/2" | 1" x 2 1/2"   | 1" x 2 3/4"   |

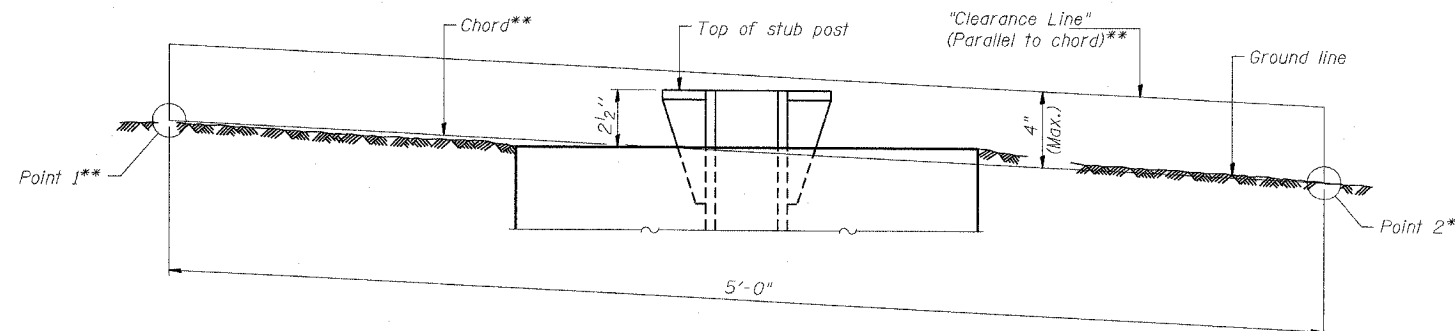

ELEVATION  
GROUND LINE & STUB POST

\*\*For all "Point 1" and "Point 2" locations, "Clearance Line" must be at or above top of stub post.

- (1) Quantity includes all concrete necessary for one foundation.
- (2) Includes reinforcement bars and spiral hooping for one foundation.

|                |                                    |
|----------------|------------------------------------|
| DESIGNED - SLW | 20                                 |
| CHECKED - PJO  | EXAMINED                           |
| DRAWN - SLW    | PASSED                             |
| CHECKED - PJO  | ENGINEER OF BRIDGES AND STRUCTURES |

ENGINEER OF STRUCTURAL SERVICES  
ENGINEER OF BRIDGES AND STRUCTURES

| NUMBER | REVISION | DATE |
|--------|----------|------|
|        |          |      |
|        |          |      |
|        |          |      |
|        |          |      |

BAW-A-2 11/1/2002

**BREAK-AWAY WIDE FLANGE  
STEEL SIGN POST TABLES**

F.A.I. 94/90 (DAN RYAN EXPRESSWAY)  
31ST STREET TO I-57

(Sheet 2 of 2)

m:\p\40466\EB\N\97\SS\A\Contract\2\SSC2042A37 09/15/2004 09:35:27 AM