

STATE OF ILLINOIS
DEPARTMENT OF TRANSPORTATION

F.A.I. RTE.	SECTION	COUNTY	TOTAL SHEETS	SHEET NO.
90/94	2021-922PT.1-AC	COOK	460	278
STA.	TO STA.			
FED. ROAD DIST. NO. 1	ILLINOIS	FED. AID PROJECT		

62693

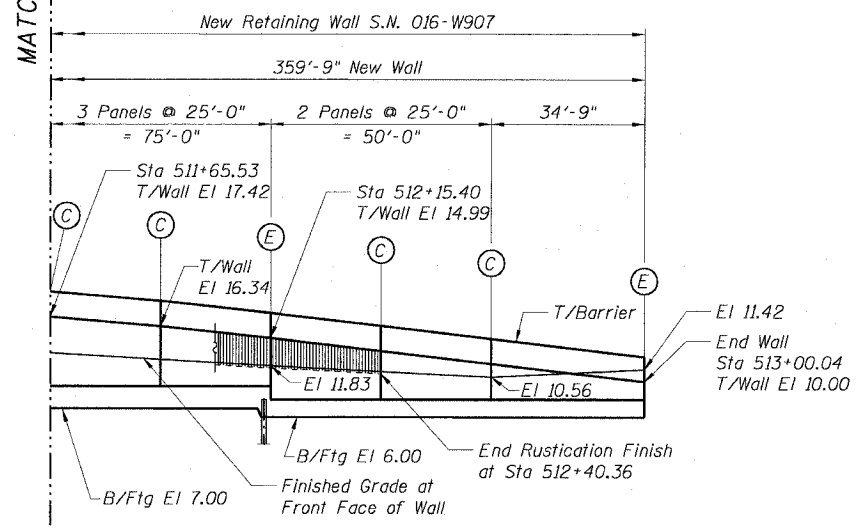
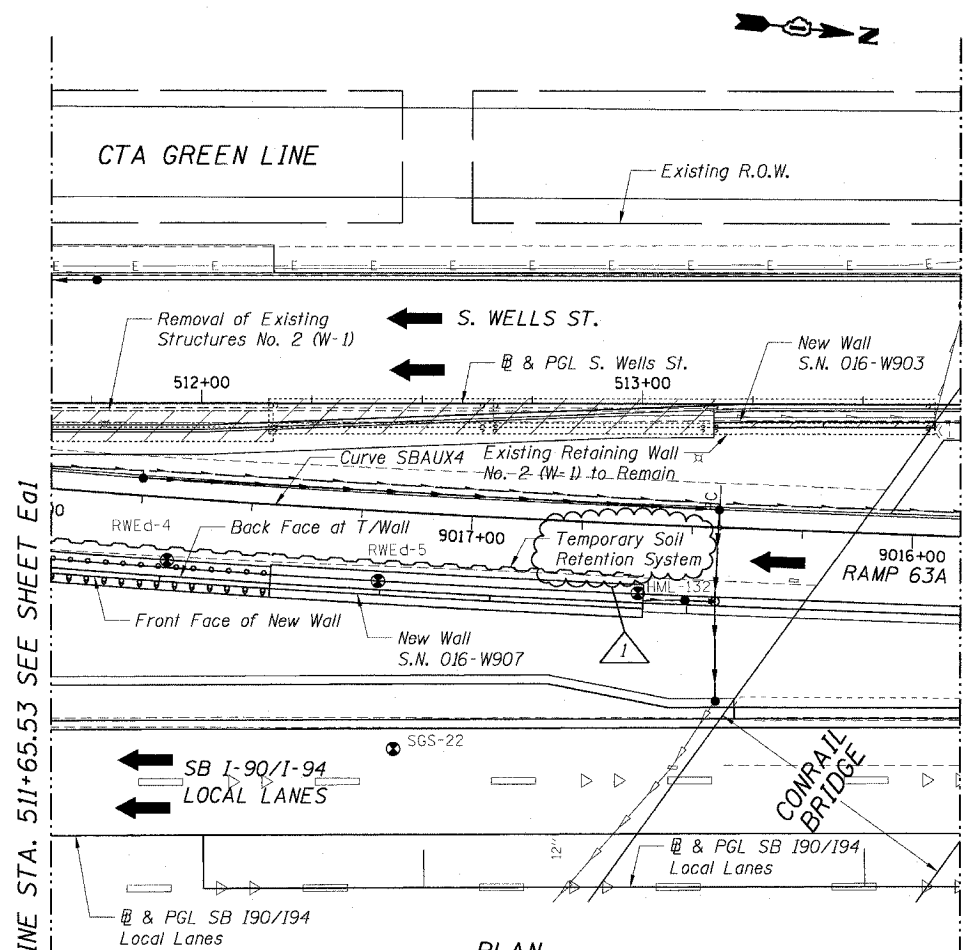

FRONT FACE ELEVATION
(Looking West)

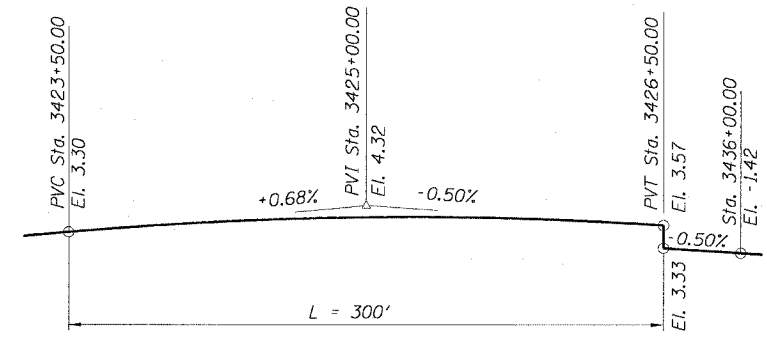

PROFILE GRADE - SB I-90/I-94 LOCAL LANES
(Along \bar{M} of Roadway)

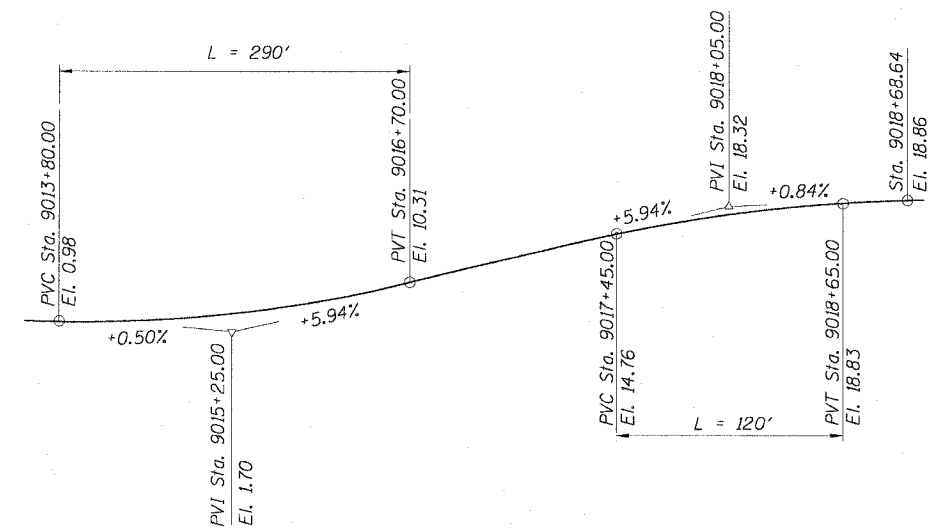

PROFILE GRADE - RAMP 63A
(Along \bar{M} of Roadway)

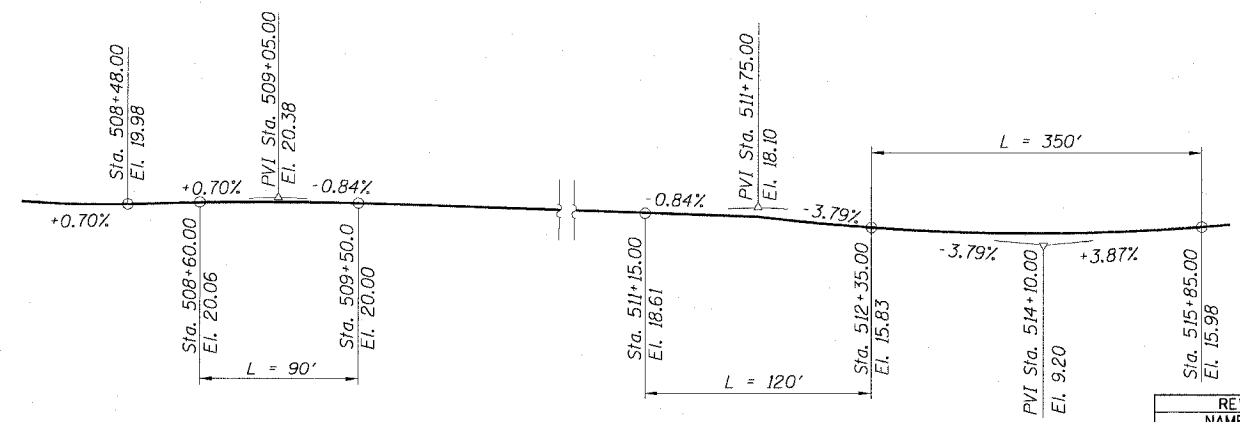

PROFILE GRADE - S. WELLS ST.
(Along \bar{M} of Roadway)

GENERAL NOTES:

- Station and offsets are measured from \bar{M} & PGL S. Wells St. to the front face of the retaining wall.
- Existing utilities in conflict with retaining wall shall be abandoned or relocated according to directions given in the Roadway Plans.
- All construction joints shall be bonded.
- All exposed concrete edges shall have a $\frac{3}{4}$ " by 45° chamfer except where shown otherwise. Chamfer on vertical edges shall be continued a minimum of 1 foot below the finished ground line.
- A protective coat shall be applied according to Section 503.19 of the Standard Specifications to all concrete surfaces not in contact with soil.
- The back face of Retaining Wall shall be waterproofed according to Article 503.18 of Standard Specifications.
- Reinforcement bars shall conform to the requirements of AASHTO M31 or M322, Grade 60.
- Reinforcement bars designated "E" shall be epoxy coated.
- The Contractor shall protect the earth in front of existing and proposed retaining walls during construction of light tower foundations and service pads. For light tower foundations in front of the new retaining walls, the Contractor shall coordinate the construction of the retaining walls, light tower foundations, and service pads to occur concurrently. If the Contractor does not perform the work concurrently he shall provide a temporary soil retention system to protect the retaining wall from being undermined during light tower construction work which shall be included in the cost of the light tower foundation work.

NOTES:

- For Index of Sheets see Sheet Ea1.
- For Legend and Abbreviations see Sheet Ea1.

CURVE SBAUX4

P.I. STA= 9017+58.36
 N= 1,863,599.16
 E= 1,175,605.59
 Δ = 3° 38' 40"
 D= 1° 35' 30"
 R= 3600.00'
 T= 114.53'
 L= 228.99'
 E= 1.82'
 e= N/A
 T.R.= N/A
 S.E. RUN= N/A
 P.C. STA= 9016+43.83
 N= 1,863,713.69
 E= 1,175,606.54
 P.T. STA= 9018+72.82
 N= 1,863,484.92
 E= 1,175,597.35

REVISIONS	
NAME	DATE
MK	01/06/05

Sheet Ea2 of 12
 ILLINOIS DEPARTMENT OF TRANSPORTATION
 F.A.I. 90/94 (DAN RYAN EXPRESSWAY)
GENERAL PLAN II
SOUTH WELLS STREET RETAINING WALL
 WEST 63RD STREET TO WEST 62ND STREET
 SECTION (2021-922PT.1-AC)
 STATION 509+41.43 TO 513+00.04
 COOK COUNTY SN. 016-W907
 SCALE: None DRAWN BY: ET/CHD
 DATE: October 29, 2004 CHECKED BY: CG/AJS

