

STATE OF ILLINOIS
DEPARTMENT OF TRANSPORTATION

F.A.I. RTE.	SECTION	COUNTY	TOTAL SHEETS	SHEET NO.
90/94	2021-922PT.1-AC	COOK	460	286
STA.	TO STA.			
FED. ROAD DIST. NO. 1	ILLINOIS FED. AID PROJECT		62693	

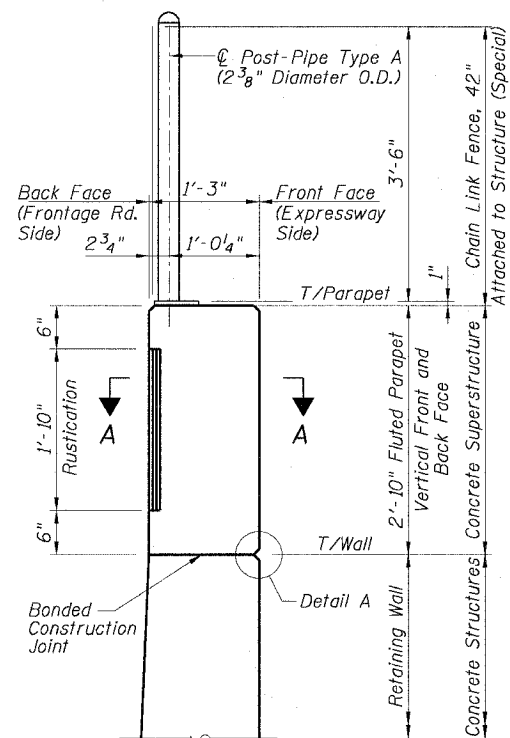

DIMENSIONS

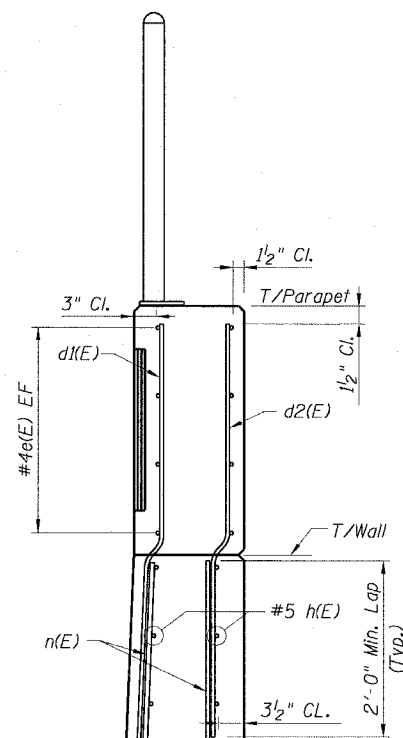

REINFORCING

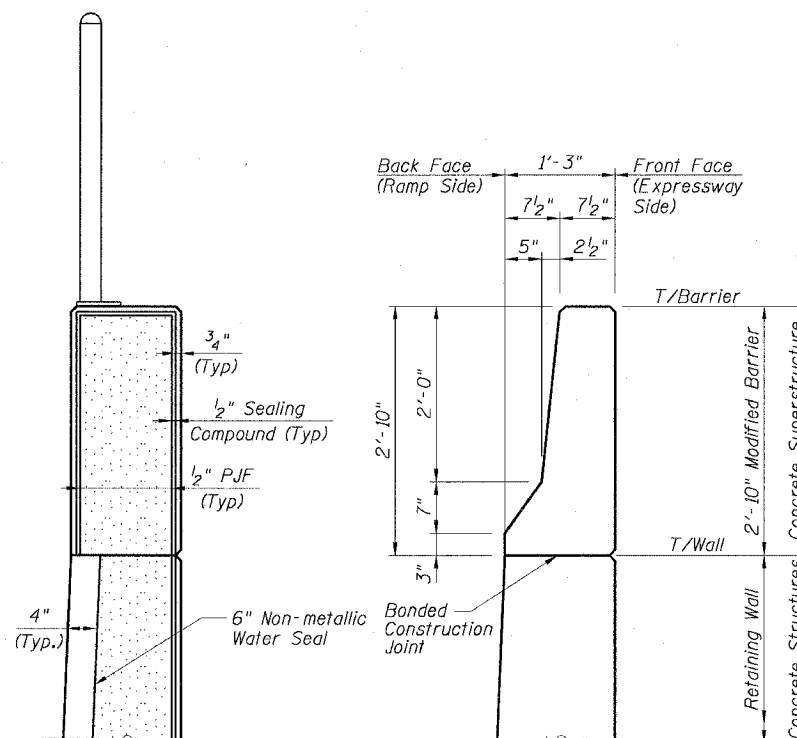

EXPANSION JOINT

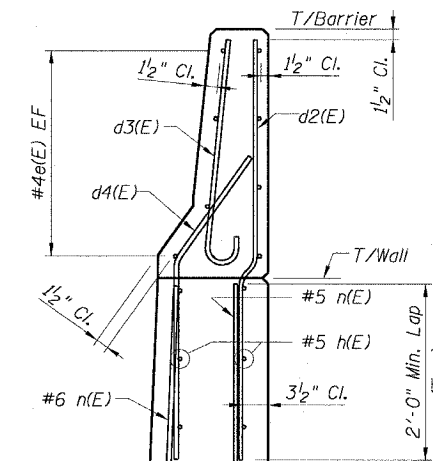

REINFORCING

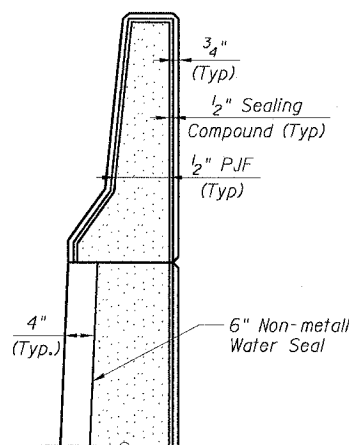

EXPANSION JOINT

TYPICAL SECTIONS - FLUTED PARAPET

(Looking North)

TYPICAL SECTIONS - MODIFIED BARRIER

(Looking North)

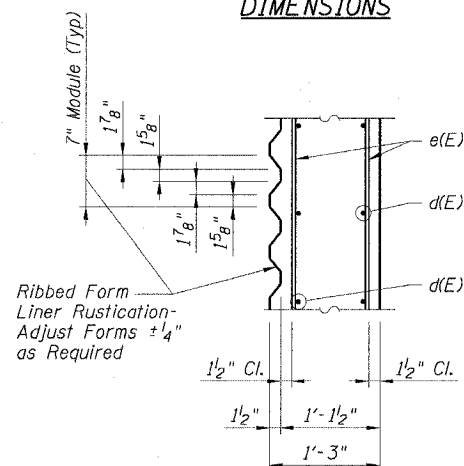

SECTION A-A

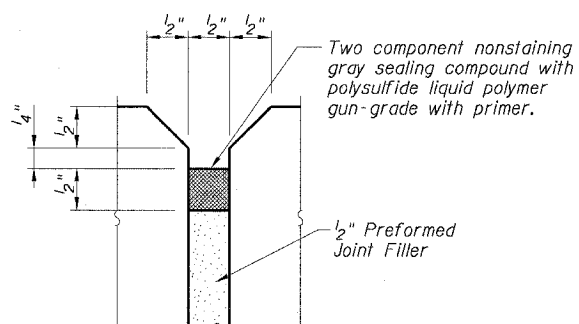

EXPANSION JOINT SEALING DETAIL

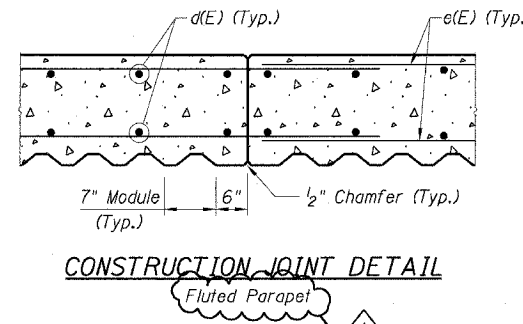

CONSTRUCTION JOINT DETAIL

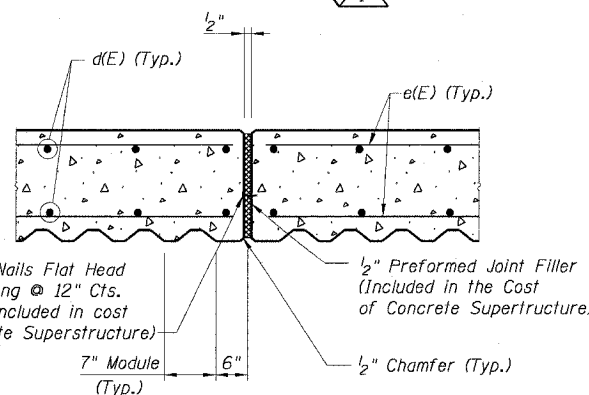

EXPANSION JOINT DETAIL

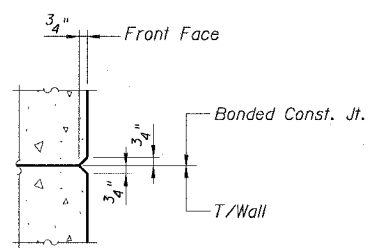

DETAIL A

LEGEND:

- Sealing Compound
- Preformed Joint Filler

NOTES:

- For Bar Bending Diagrams see Sheet Ea11.
- For Chain Link Fence, 42" Attached to Structure (Special) Detail see Sheet SD1.

REVISIONS	
NAME	DATE
CG	01/06/05