

STATE OF ILLINOIS
DEPARTMENT OF TRANSPORTATION

F.A.I. RTE.	SECTION	COUNTY	TOTAL SHEETS	SHEET NO.
90/94	2021-922PT.1-AC	COOK	460	324
STA.	TO STA.			
FED. ROAD DIST. NO. 1	ILLINOIS	FED. AID PROJECT		

62693

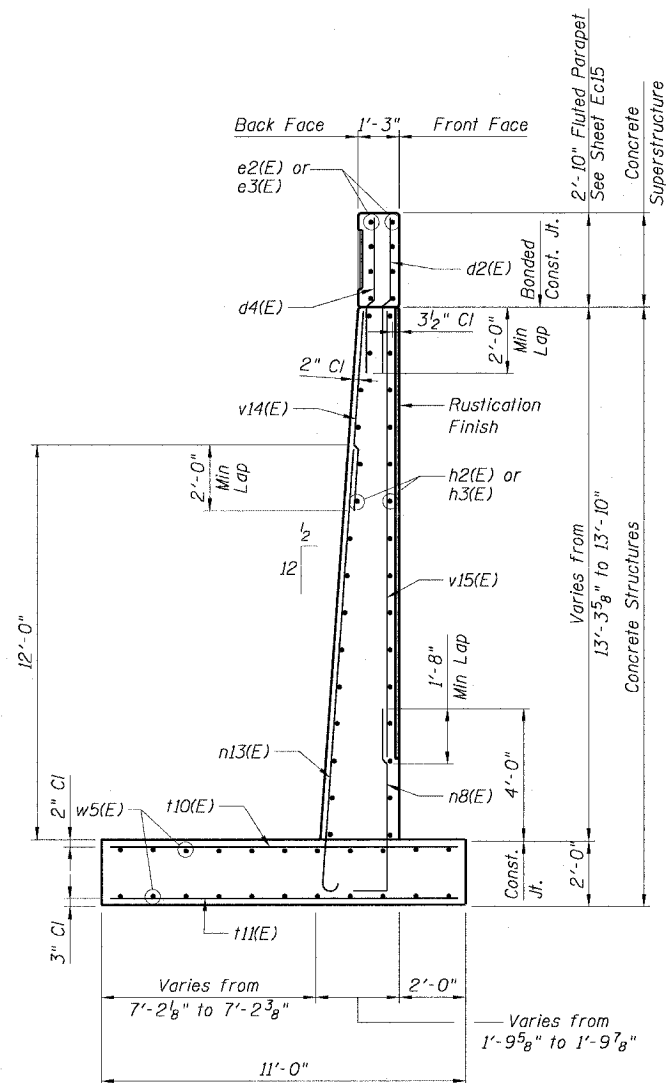

SECTION I-I

Sta. 530+23.57 to Sta. 531+23.44
Maximum Applied Bearing Pressure: 3,60 Ksf

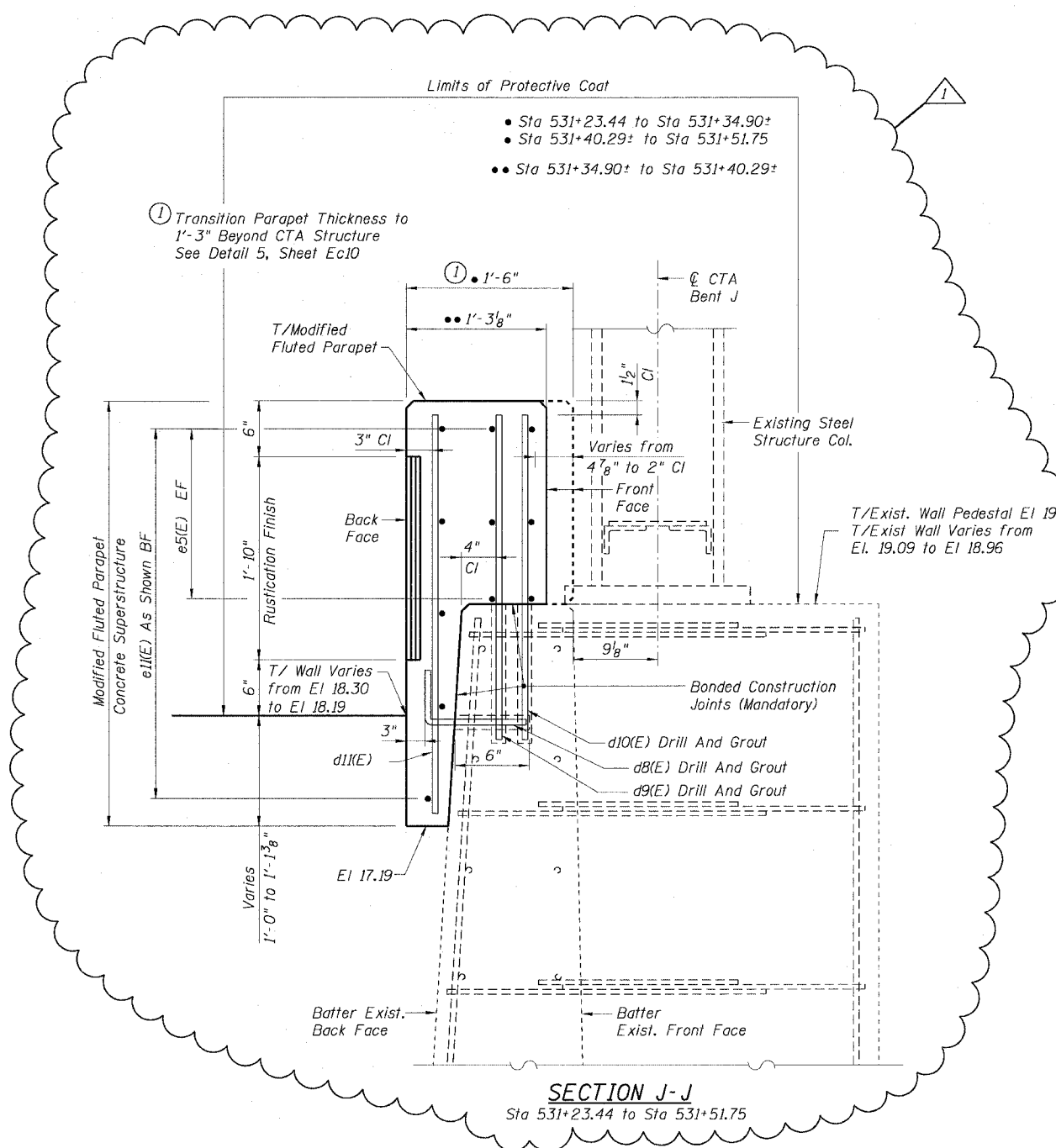

SECTION J-J

Sta 531+23.44 to Sta 531+51.75

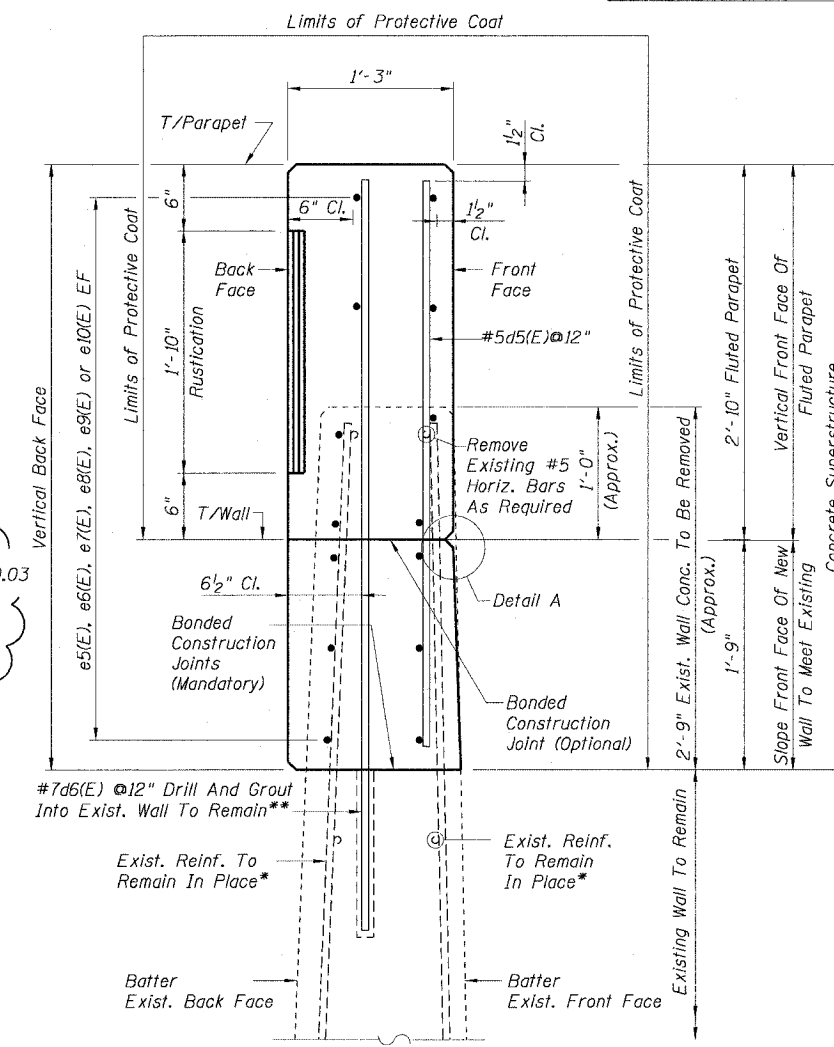

SECTION K-K

Sta 532+14.80 to Sta 533+88.42

* Existing Reinforcing Steel which is exposed by the Concrete Removal process, but which is to remain partially embedded in the Existing Structure, shall be cleaned to be free of existing concrete and rust, straightened if necessary, and recast into the New Concrete. The cost is included in Concrete Removal.

** Drill and Grout #7 Bars in 1 1/8" Dia. Drilled Holes with a min. depth of 15 inches, according to Art. 584 of the Standard Specifications. (Cost included with Reinforcement Bars, Epoxy Coated)

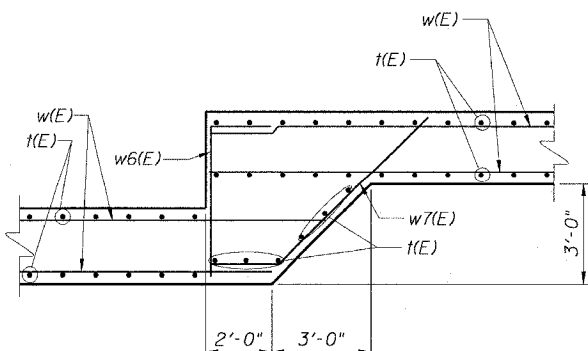

DETAIL 1

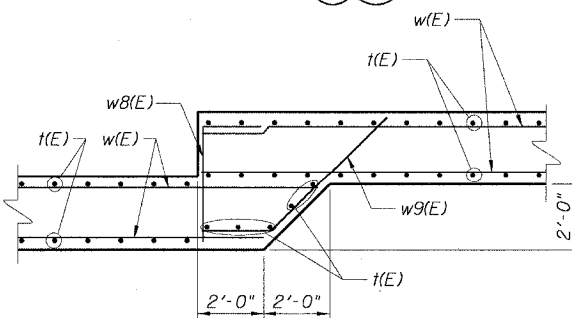

DETAIL 2

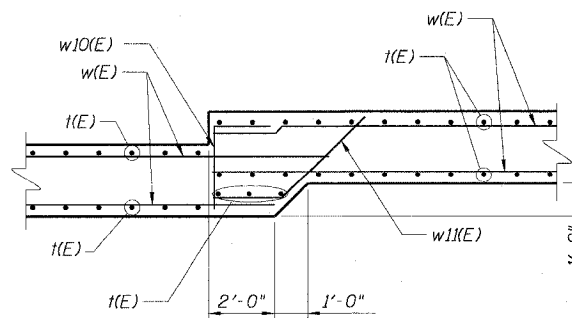

DETAIL 3



REVISIONS	
NAME	DATE
CG	01/06/05

Sheet Ec13 of 20
ILLINOIS DEPARTMENT OF TRANSPORTATION
F.A.I. 90/94 (DAN RYAN EXPRESSWAY)
WALL SECTIONS
SOUTH WELLS ST. RETAINING WALL
WEST 61ST STREET TO WEST 59TH STREET
SECTION 2021-922PT.1-AC
STATION 523+36.03 TO STATION 533+88.42
COOK COUNTY S.N. 016-W964, 016-W894
SCALE: None DRAWN BY: ET/CHD
DATE: October 29, 2004 CHECKED BY: CJK/AJS

01/06/2005 02:48:53 PM