

ROUTE NO.	SECTION	COUNTY	TOTAL SHEETS	SH
F.A.P. 697	17BR-1	FORD	42	
ILLINOIS				

CONTRACT NO. 66363

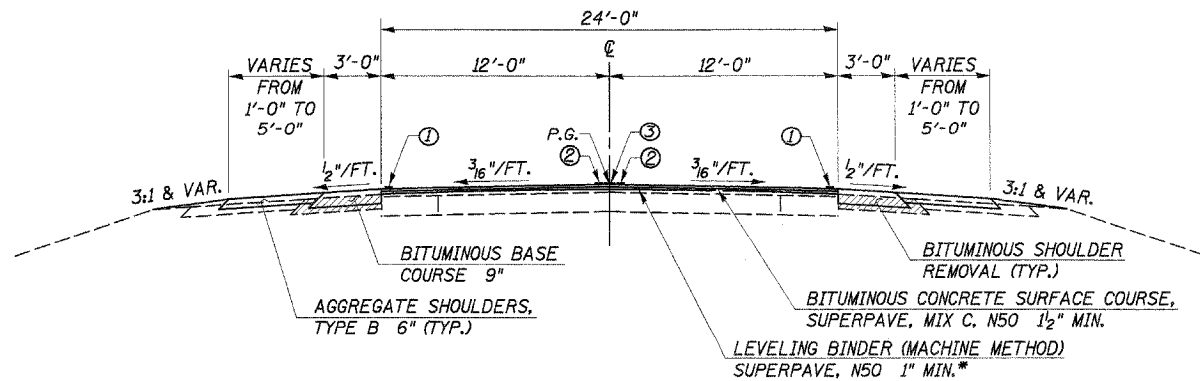

**PROPOSED ROADWAY TYPICAL SECTION**

RT. STA. 989+00 TO STA. 990+38.35  
 LT. STA. 989+00 TO STA. 991+38.35  
 \*STA. 990+72 TO STA. 992+83

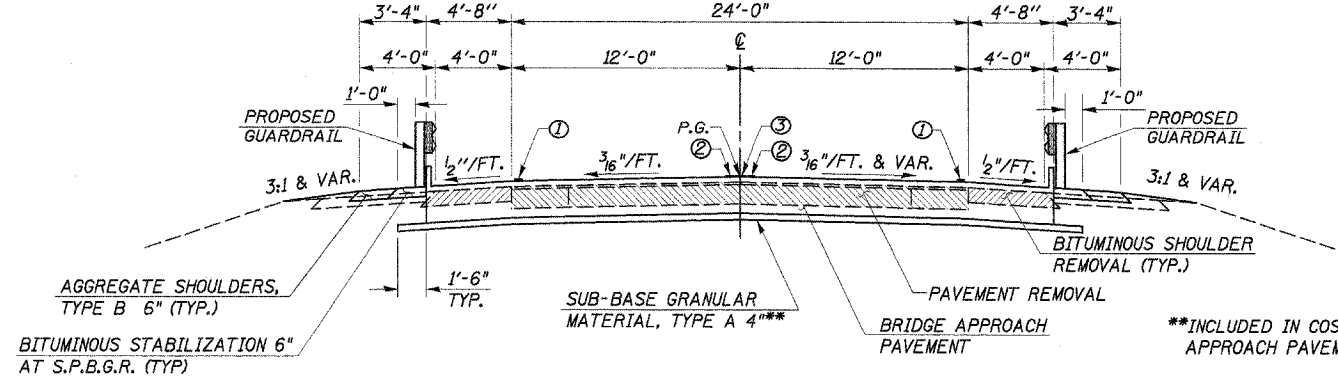

**PROPOSED ROADWAY TYPICAL SECTION**

RT. STA. 992+89.00 TO STA. 993+19.00  
 STA. 994+41.75 TO STA. 994+71.75

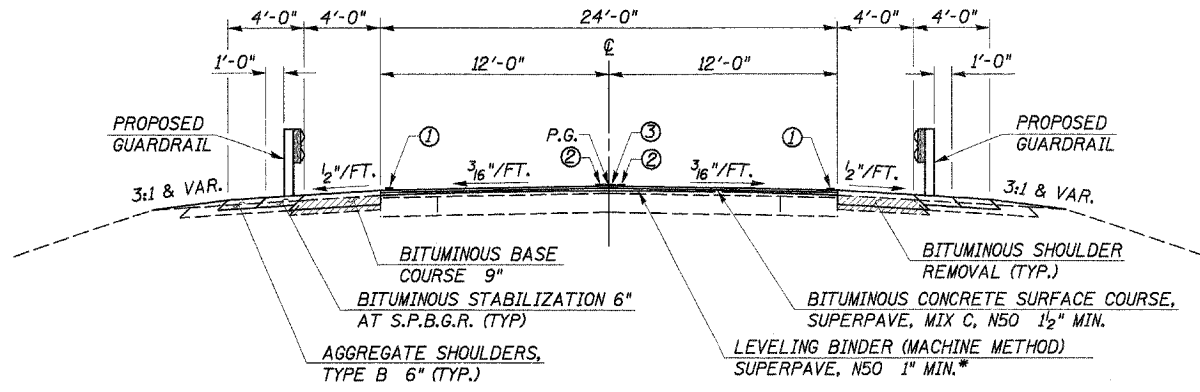

**PROPOSED ROADWAY TYPICAL SECTION**

RT. STA. 990+38.35 TO STA. 992+83.00  
 LT. STA. 991+38.35 TO STA. 992+83.00  
 \*STA. 990+72 TO STA. 992+83

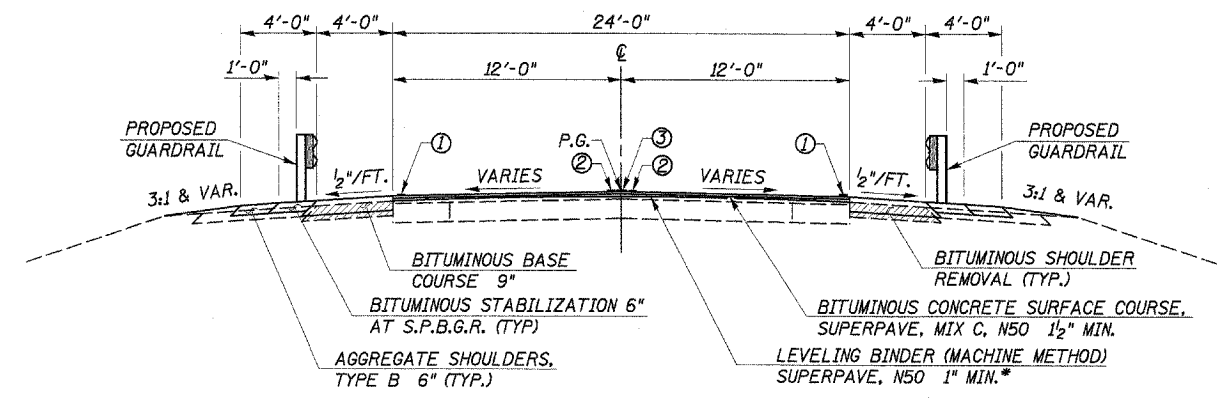

**PROPOSED ROADWAY TYPICAL SECTION**

RT. STA. 994+77.75 TO STA. 995+22.40  
 LT. STA. 994+77.75 TO STA. 995+47.40  
 \*STA. 994+77.75 TO STA. 995+07

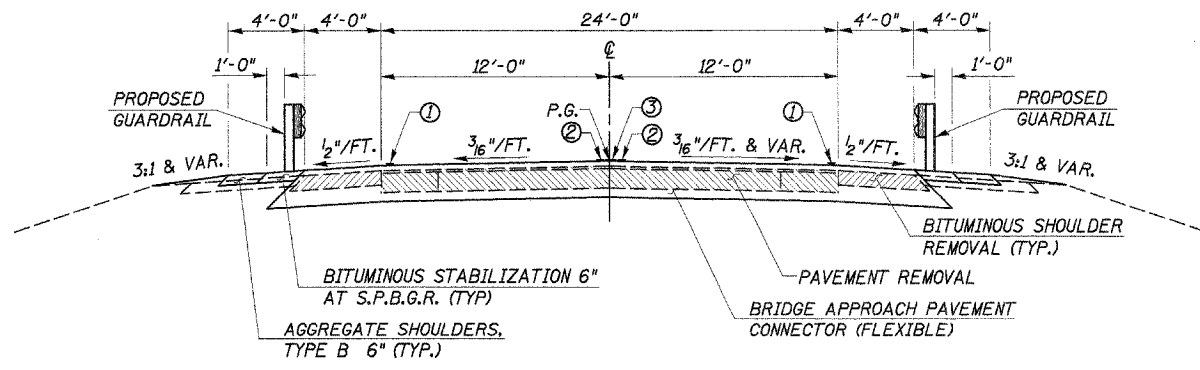

**PROPOSED ROADWAY TYPICAL SECTION**

STA. 992+83.00 TO STA. 992+89.00  
 STA. 994+71.75 TO STA. 994+77.75

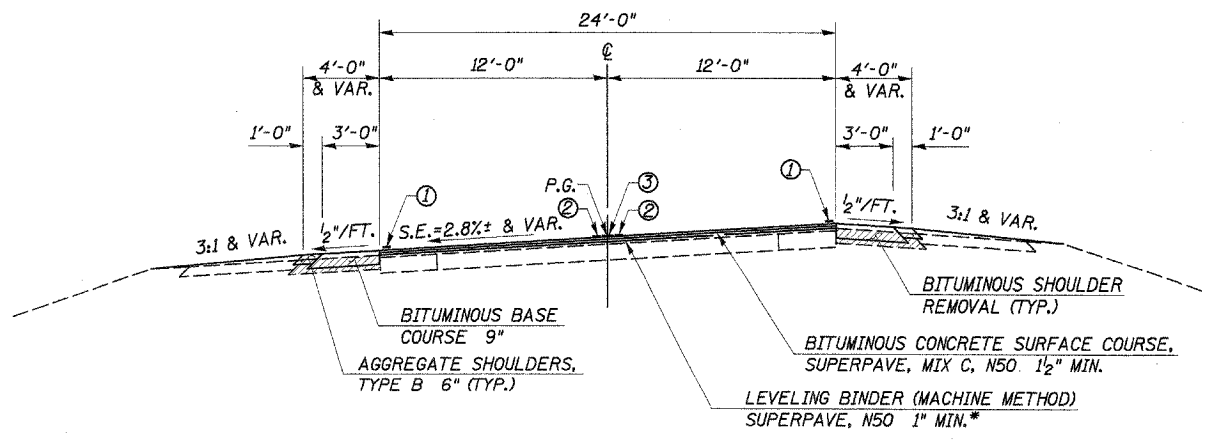

**PROPOSED ROADWAY TYPICAL SECTION**

RT. STA. 995+22.40 TO STA. 998+00.00  
 LT. STA. 995+47.40 TO STA. 998+00.00

- ① EDGE LINE (4" SOLID WHITE)
- ② NO PASSING LINE (4" SOLID YELLOW)
- ③ CENTERLINE (6" SKIP-DASH YELLOW)

**PROPOSED TYPICAL SECTIONS**

FAP 697 (IL. RTE. 9) OVER  
 WALL TOWN DRAINAGE DITCH  
 SECTION 17BR-1  
 FORD COUNTY  
 S.N. 027-0094

4440 ASH GROVE SPRINGFIELD, IL. 62707 (217) 793-8600 casino@tamvid.com	<b>OZYURT AND STONE, INC.</b> CONSULTING ENGINEERS	JOB NO.: 0306.2 FILE: TYP02.DWG DATE: 08-17-0
---	---	---