

F.A.P. RTE.	SECTION	COUNTY	TOTAL SHEETS	SHEET NO.
649		LIVINGSTON	15	8
STA.		TO STA.		
FED. ROAD DIST. NO.		ILLINOIS FED. AID PROJECT		

*116/RS-4,(17,28)RS-2

NE CORNER, NW 1/4 SEC. 8
T30N, R6E

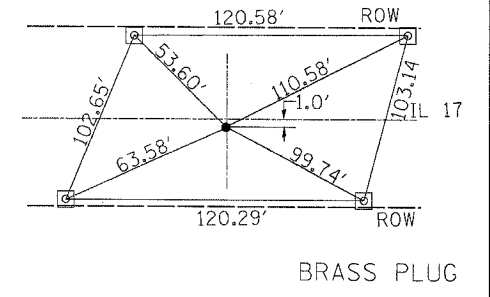

NE CORNER, NW 1/4 SEC. 7
T30N, R6E

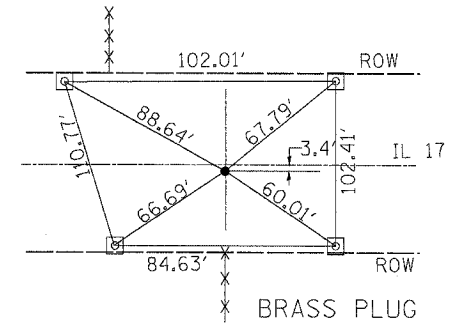

NE CORNER SEC. 11
T30N, R5E

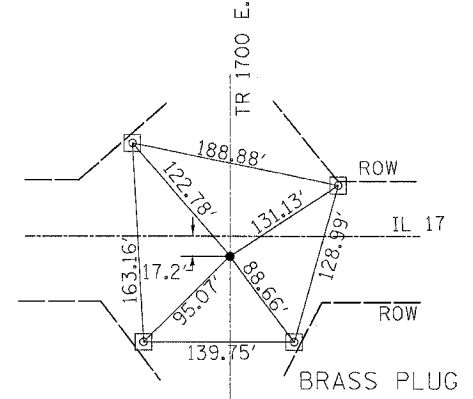

NE CORNER, NW 1/4 SEC. 10
T30N, R5E

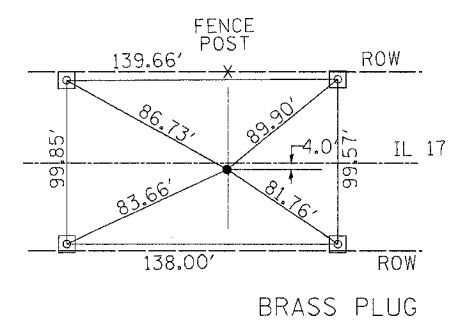

NE CORNER SEC. 8
T30N, R5E

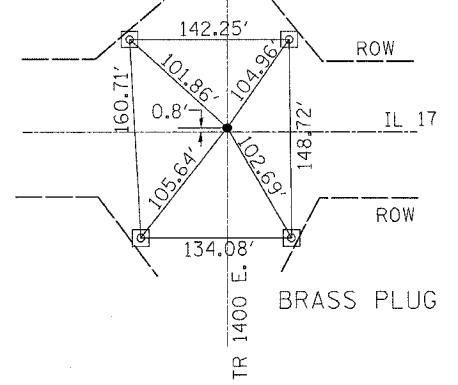

NW CORNER, NE 1/4 SEC. 7
T30N, R5E

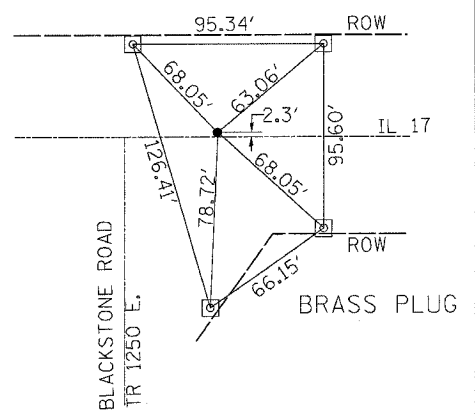

NE CORNER SEC. 8
T30N, R6E

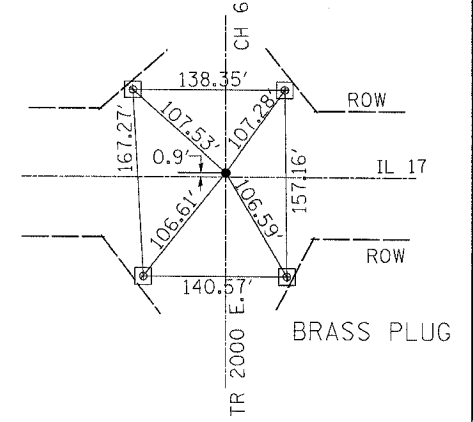

NE CORNER SEC. 7
T30N, R6E

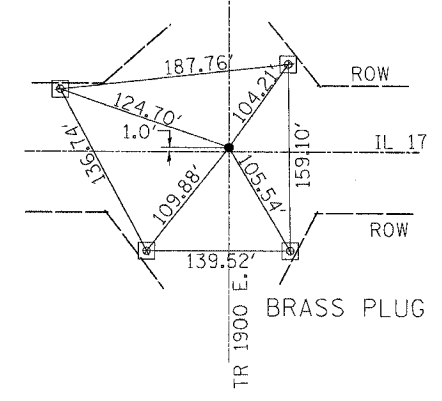

NE CORNER, NW 1/4 SEC. 12
T30N, R5E

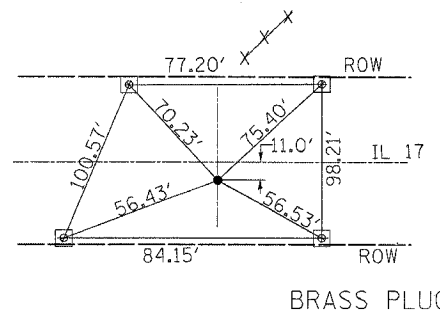

SE CORNER SEC. 3
T30N, R5E

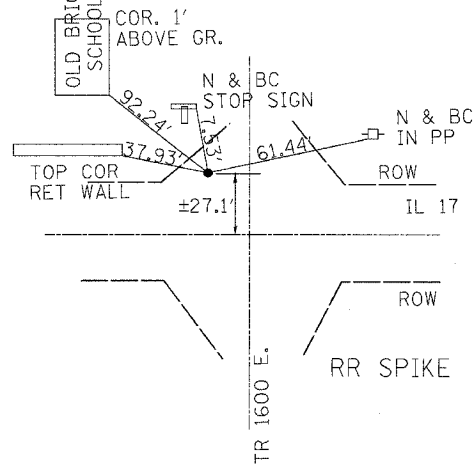

NE CORNER, NW 1/4 SEC. 9
T30N, R5E

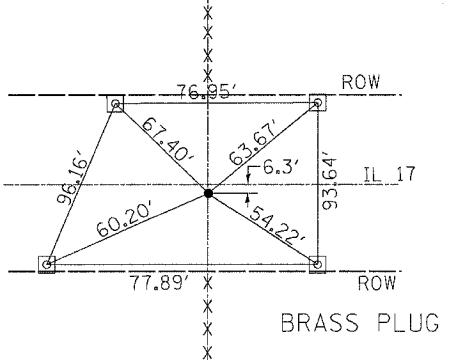

NE CORNER SEC. 7
T30N, R5E

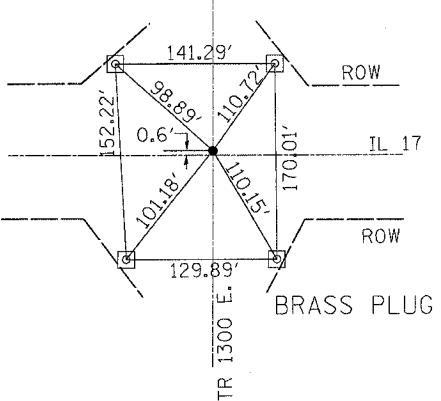

NE CORNER SEC. 12
T30N, R5E

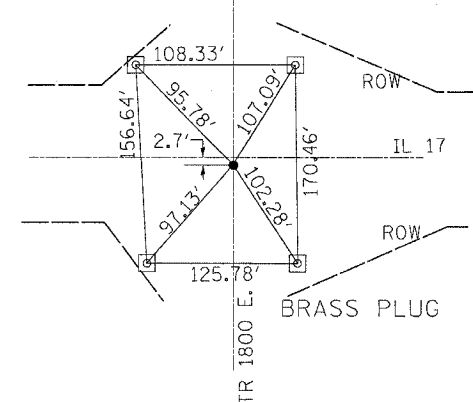

NE CORNER, NW 1/4 SEC. 11
T30N, R5E

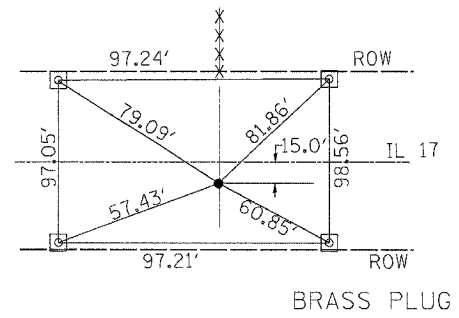

NW CORNER SEC. 10
T30N, R5E

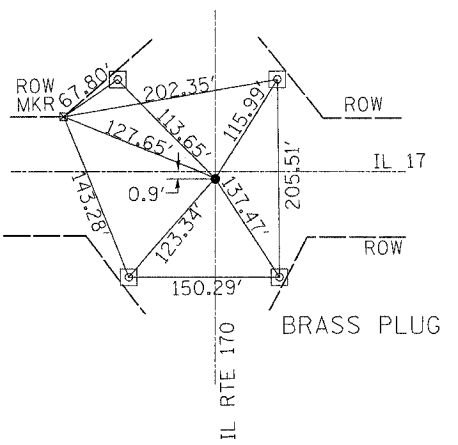

NE CORNER, NW 1/4 SEC. 8
T30N, R5E

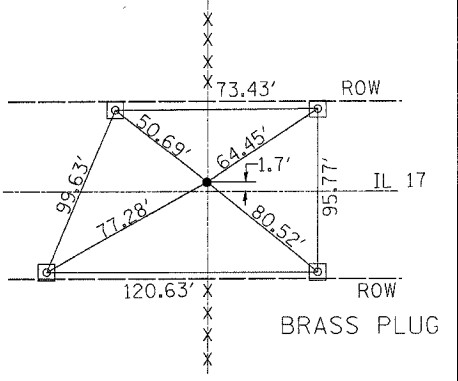

ILLINOIS DEPARTMENT OF TRANSPORTATION

TIE POINTS

REVISIONS	NAME	DATE

SCALE: VERT. DATE
HORIZ. DRAWN BY
CHECKED BY

PLOT DATE = 11/2/2004
FILE NAME = #FILE#
PLOT SCALE = #SCALE#
REFERENCE = #REF#