

10 8 6 4 2 0 2 4 6 8 10 12 14 16 18

BIKE PATH

10 8 6 4 2 0 2 4 6 8

BIKE PATH

F.A. RTE.	SECTION	COUNTY	TOTAL SHEETS	SHEET NO.
	02-00090-00-BT	DUPAGE	117	110
STA.	TO STA.			
FED. ROAD DIST. NO.	ILLINOIS FED. AID PROJECT			
	CONTRACT NO. 83713			

DATE	BY
DESIGNED	BLANKED
DRAWN	SAFETY
CHECKED	PLOTTED
IN CHARGE	NOTE BOOK
NO.	AREA CHECKED

DATE	BY
DESIGNED	BLANKED
DRAWN	SAFETY
CHECKED	PLOTTED
IN CHARGE	NOTE BOOK
NO.	AREA CHECKED

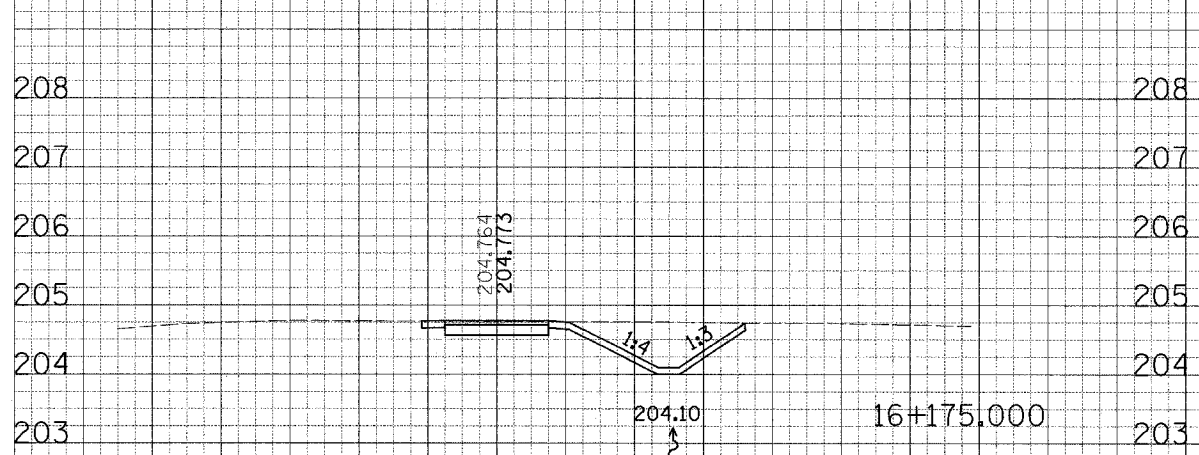

CUT: (UNSUITABLE) 2.8 SM
 CUT: (SUITABLE) 1.0 SM
 FILL: (SUITABLE) 0.6 SM

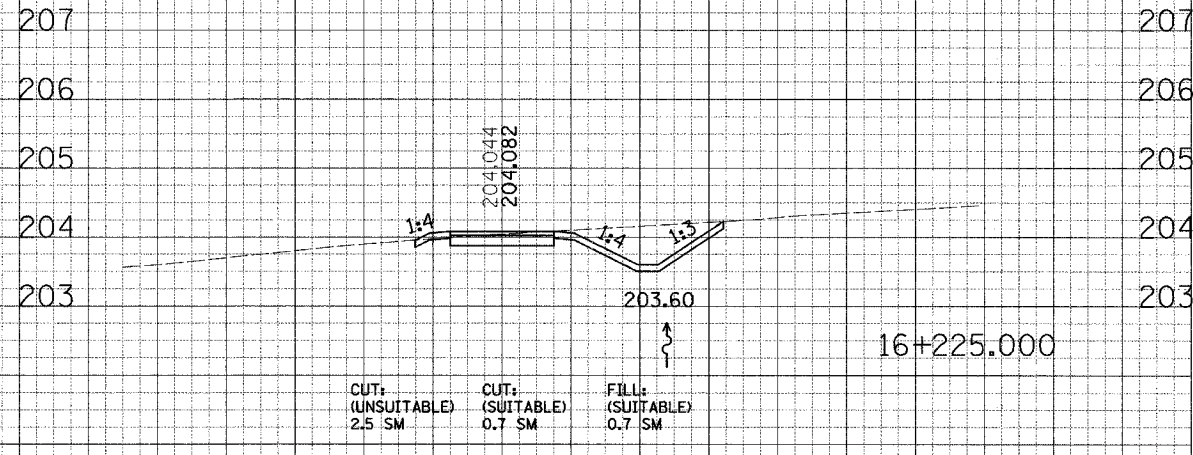

CUT: (UNSUITABLE) 2.5 SM
 CUT: (SUITABLE) 0.7 SM
 FILL: (SUITABLE) 0.7 SM

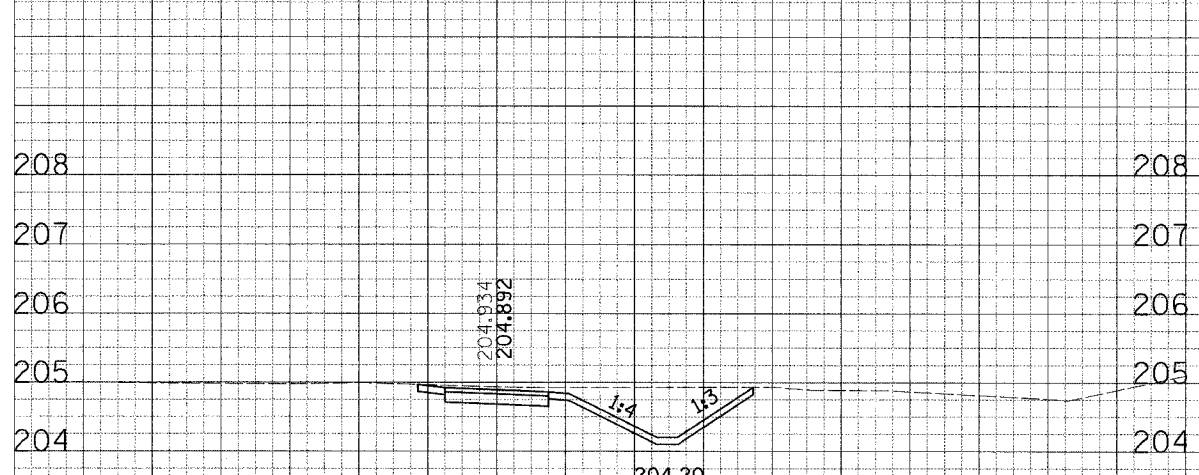

CUT: (UNSUITABLE) 2.8 SM
 CUT: (SUITABLE) 1.3 SM
 FILL: (SUITABLE) 0.3 SM

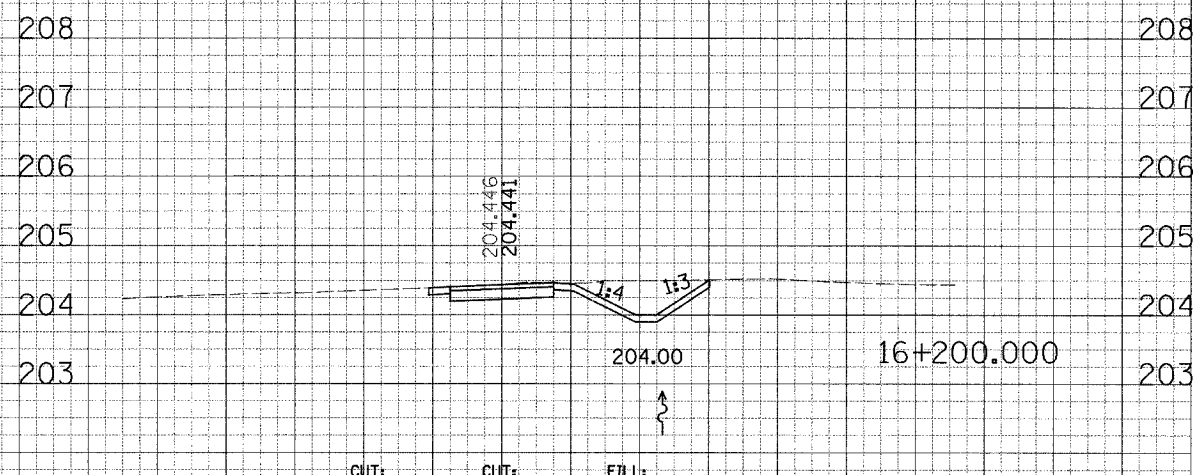

CUT: (UNSUITABLE) 2.4 SM
 CUT: (SUITABLE) 0.5 SM
 FILL: (SUITABLE) 0.6 SM

10 8 6 4 2 0 2 4 6 8 10 12 14 16 18

10 8 6 4 2 0 2 4 6 8 10 12 14 16 18