

**DETAIL 1**  
STA. 3+35 TO STA. 4+35

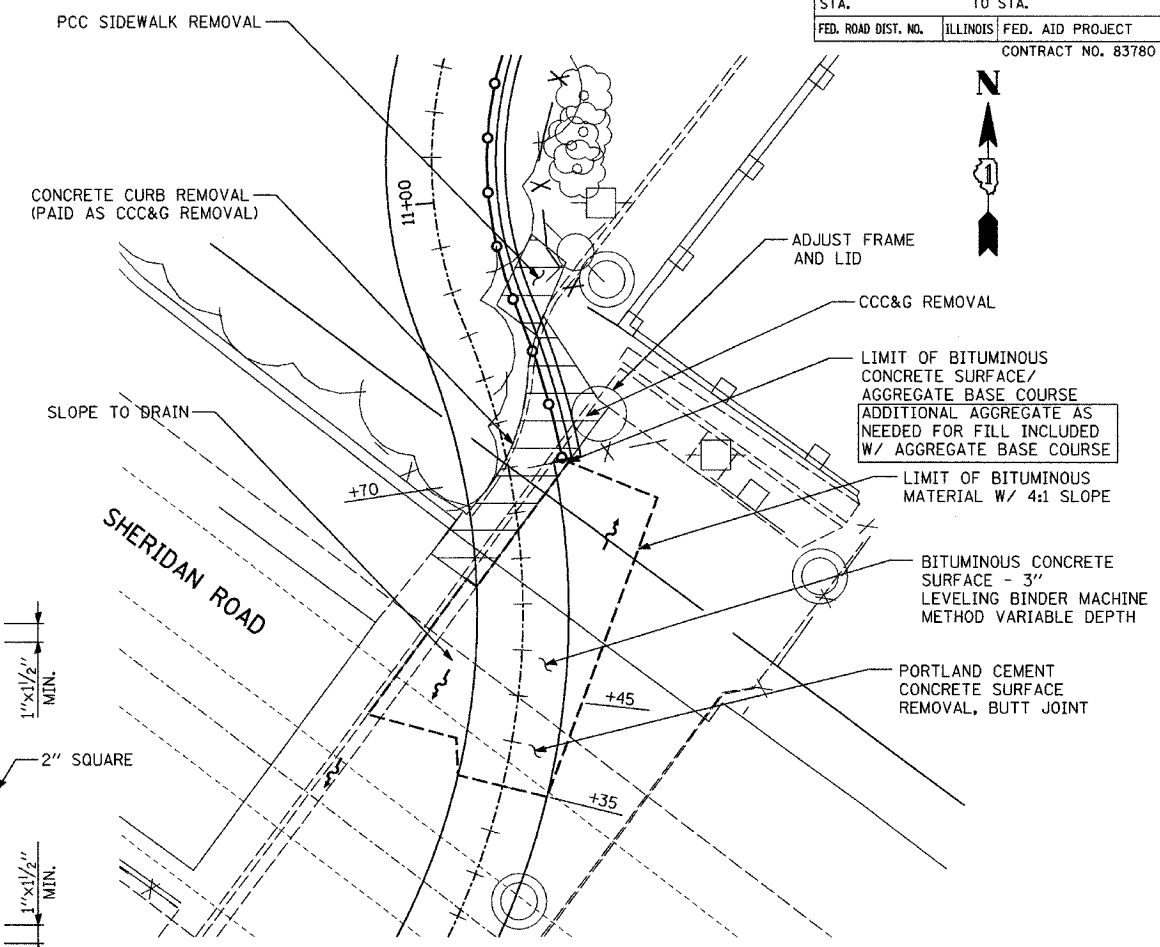

**DETAIL 2**  
STA. 10+35 TO STA. 11+00

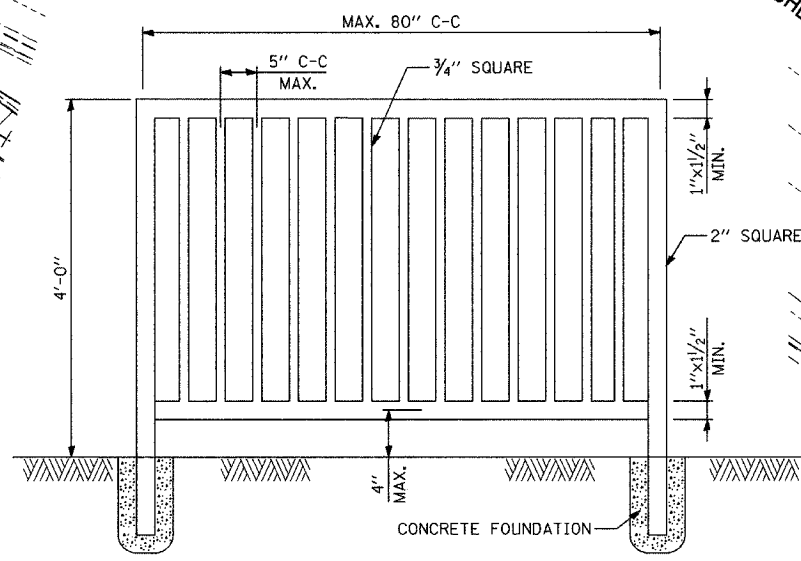

**ORNAMENTAL FENCE**

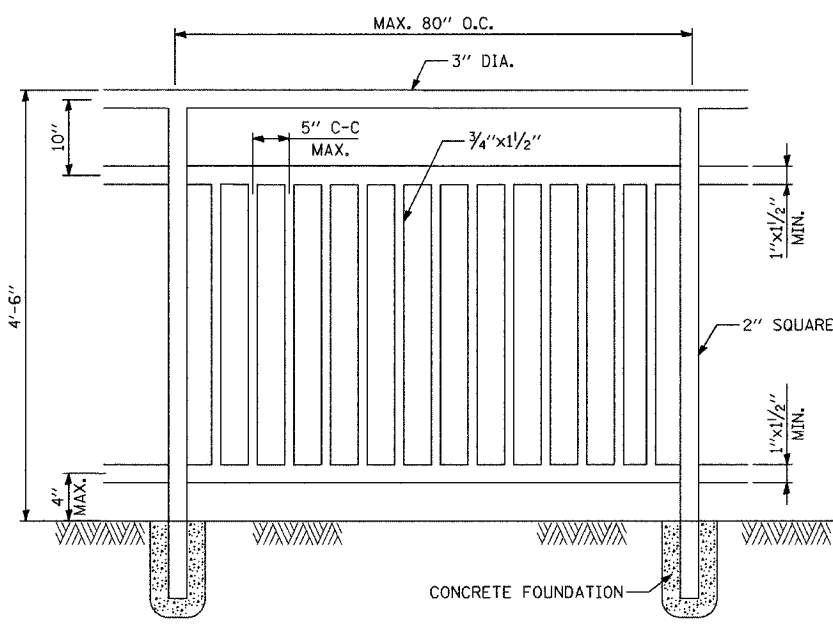

**BICYCLE RAILING**

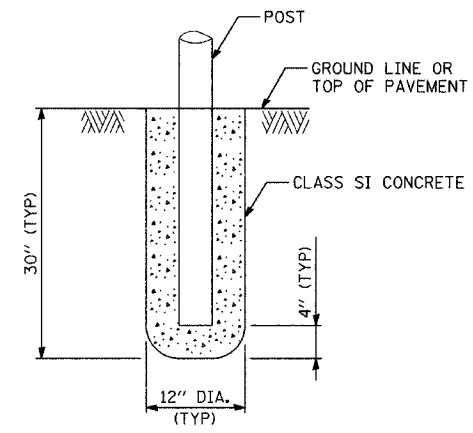

**FOOTING FOR POST**

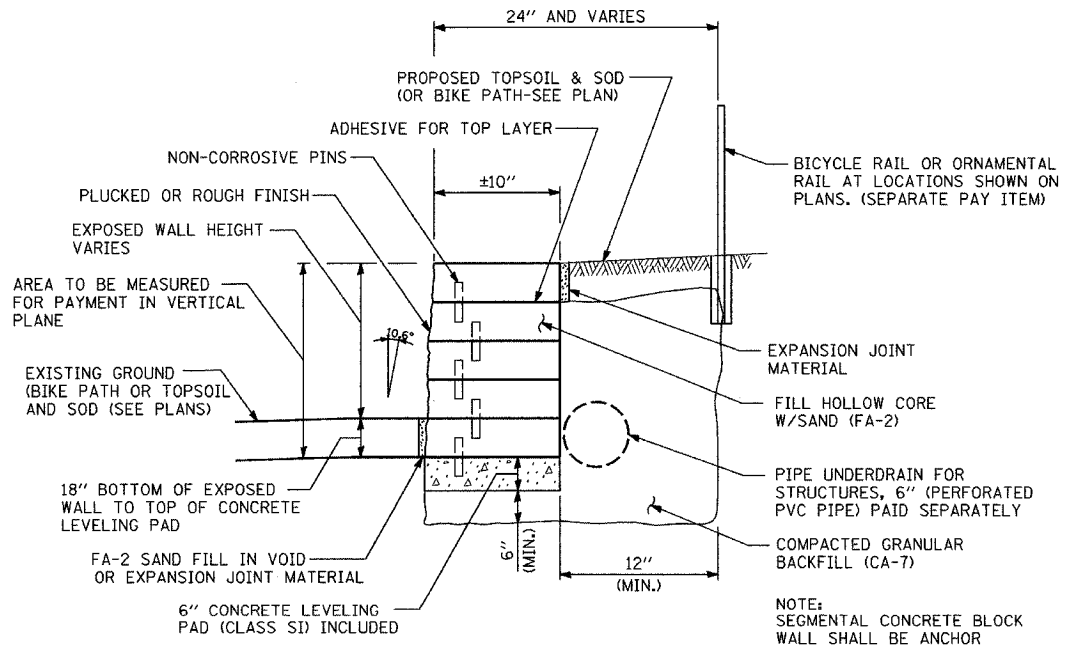

**SEGMENTAL CONCRETE BLOCK WALL**

NOTE:  
SEGMENTAL CONCRETE BLOCK WALL SHALL BE ANCHOR RETAINING WALL SYSTEMS, INC.- HIGHLAND STONE OR EQUIVALENT.

REVISIONS	
NAME	DATE

ILLINOIS DEPARTMENT OF TRANSPORTATION  
SHERIDAN ROAD BIKE PATH

DETAILS

SCALE: 1"=10'-0"  
DATE: 11/05/2004  
DRAWN BY:  
CHECKED BY:

DATE	
BY	
PROJECT	
PLANNED	
ALIGNED	
CHECKED	
NO. 1	
NO. 2	
NO. 3	
NO. 4	
NO. 5	
NO. 6	
NO. 7	
NO. 8	
NO. 9	
NO. 10	
NO. 11	
NO. 12	
NO. 13	
NO. 14	
NO. 15	
NO. 16	
NO. 17	
NO. 18	
NO. 19	
NO. 20	
NO. 21	
NO. 22	
NO. 23	
NO. 24	
NO. 25	
NO. 26	
NO. 27	
NO. 28	
NO. 29	
NO. 30	
NO. 31	
NO. 32	
NO. 33	
NO. 34	
NO. 35	
NO. 36	
NO. 37	
NO. 38	
NO. 39	
NO. 40	
NO. 41	
NO. 42	
NO. 43	
NO. 44	
NO. 45	
NO. 46	
NO. 47	
NO. 48	
NO. 49	
NO. 50	

DATE	
BY	
PROJECT	
PLANNED	
ALIGNED	
CHECKED	
NO. 1	
NO. 2	
NO. 3	
NO. 4	
NO. 5	
NO. 6	
NO. 7	
NO. 8	
NO. 9	
NO. 10	
NO. 11	
NO. 12	
NO. 13	
NO. 14	
NO. 15	
NO. 16	
NO. 17	
NO. 18	
NO. 19	
NO. 20	
NO. 21	
NO. 22	
NO. 23	
NO. 24	
NO. 25	
NO. 26	
NO. 27	
NO. 28	
NO. 29	
NO. 30	
NO. 31	
NO. 32	
NO. 33	
NO. 34	
NO. 35	
NO. 36	
NO. 37	
NO. 38	
NO. 39	
NO. 40	
NO. 41	
NO. 42	
NO. 43	
NO. 44	
NO. 45	
NO. 46	
NO. 47	
NO. 48	
NO. 49	
NO. 50	