

F.A.U. RTE.	SECTION	COUNTY	TOTAL SHEETS	SHEET NO.
2652	00-00069-00-PV	DUPAGE	146	60
STA. 10+70.70		TO STA. 66+16.00		
FED. ROAD DIST. NO.		ILLINOIS FED. AID PROJECT		
CONTRACT NO. 83781				

DATE	BY	REVISIONS

DATE	BY	REVISIONS

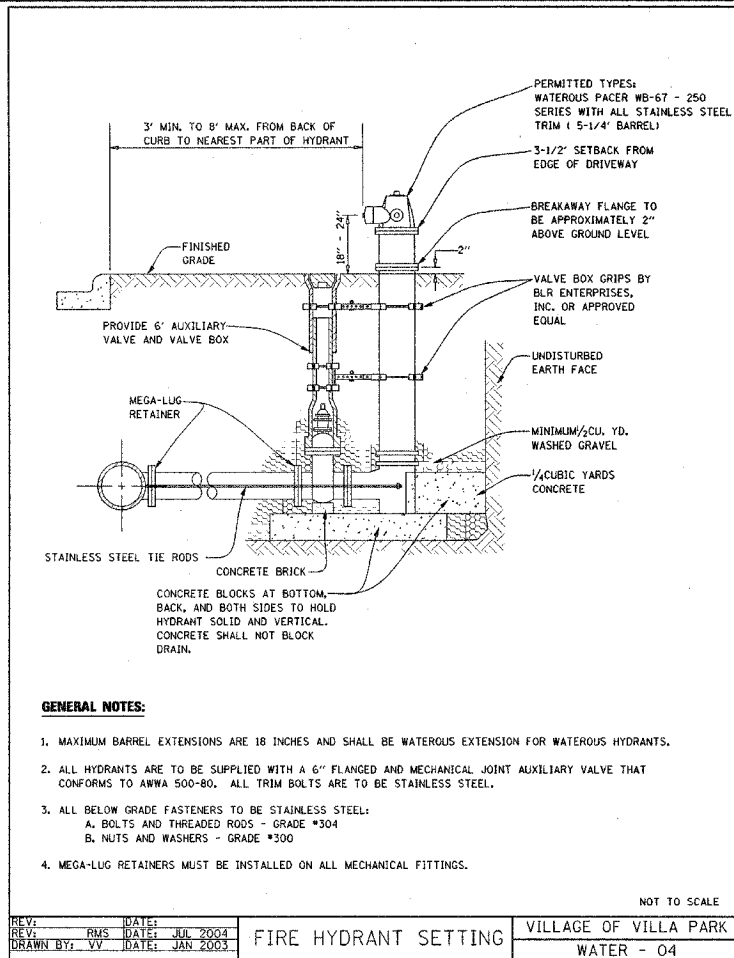

REV: _____ DATE: _____	VILLAGE OF VILLA PARK
REV: RMS DATE: JUL 2004	WATER - 04
DRAWN BY: VV DATE: JAN 2003	

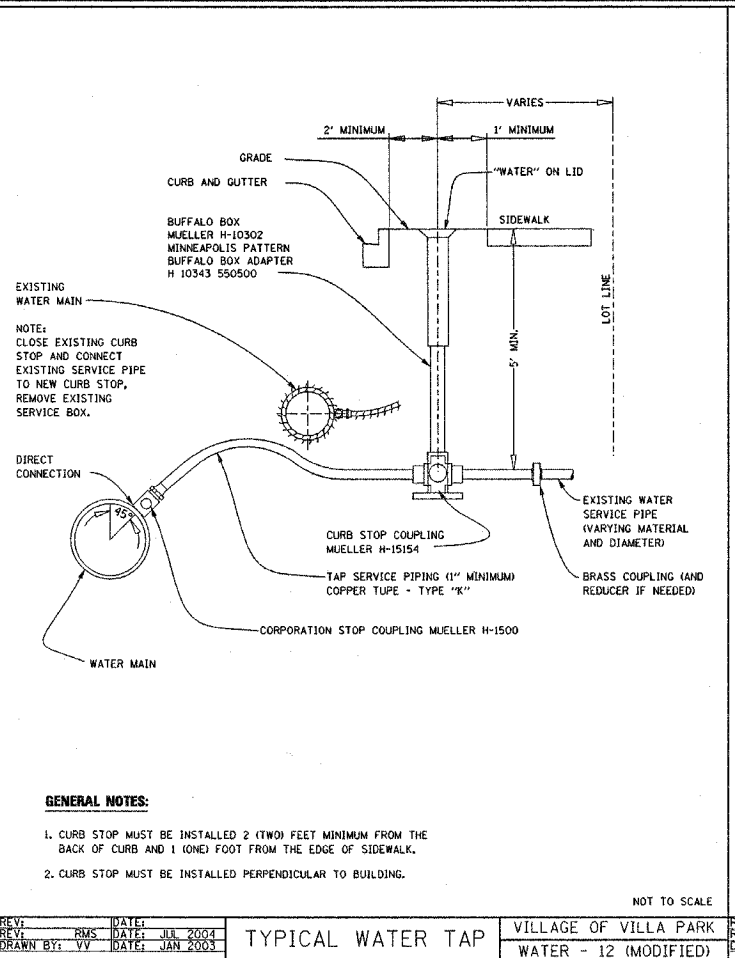

REV: _____ DATE: _____	VILLAGE OF VILLA PARK
REV: RMS DATE: JUL 2004	WATER - 12 (MODIFIED)
DRAWN BY: VV DATE: JAN 2003	

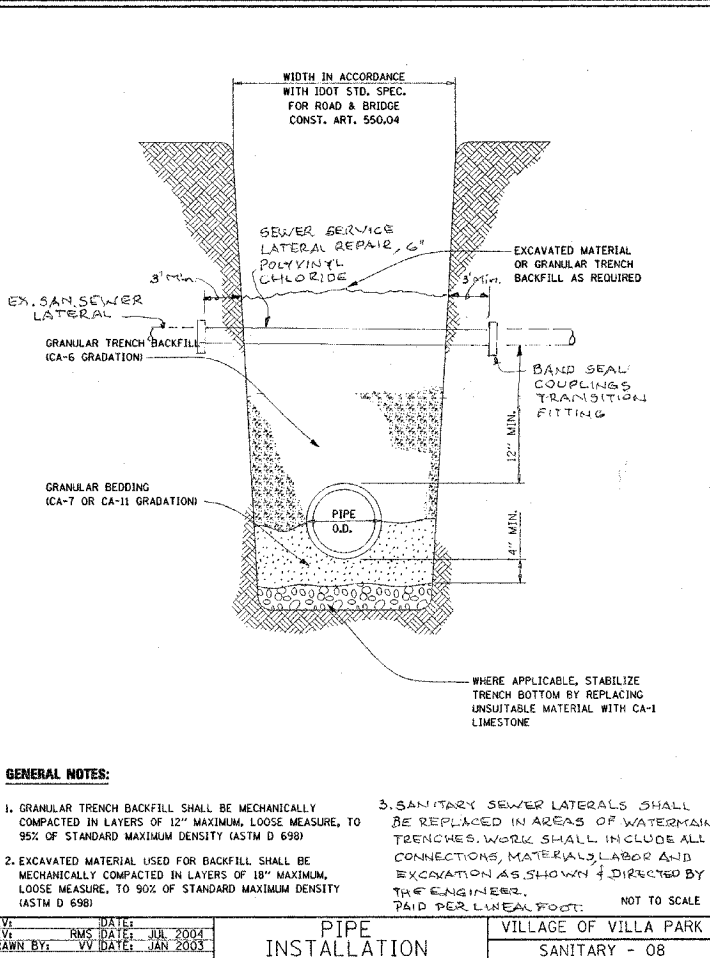

REV: _____ DATE: _____	VILLAGE OF VILLA PARK
REV: RMS DATE: JUL 2004	SANITARY - 08
DRAWN BY: VV DATE: JAN 2003	

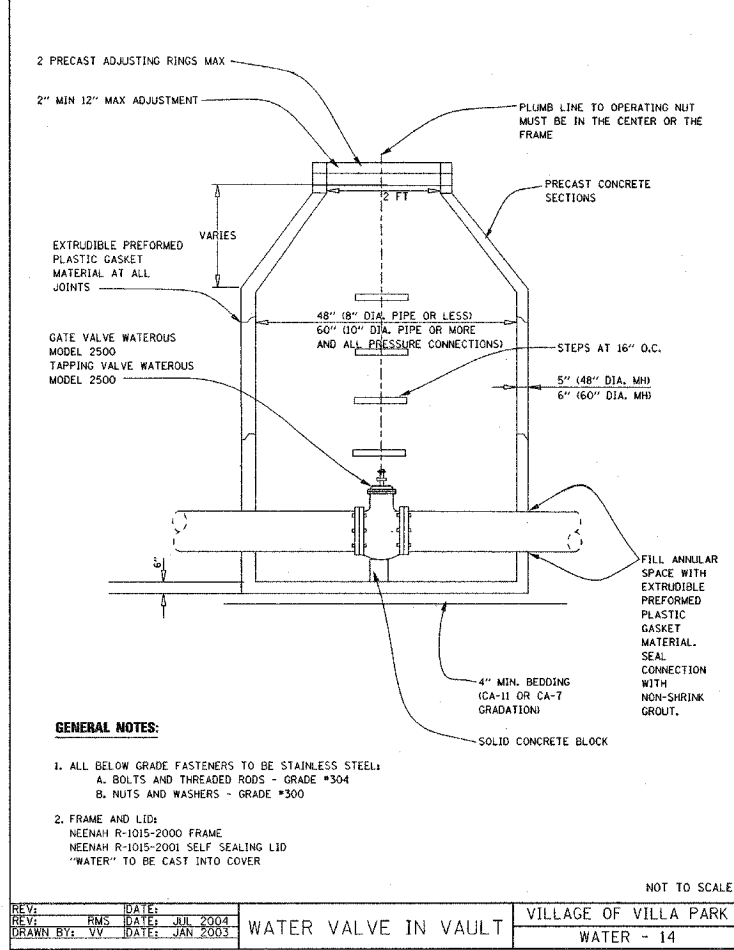

REV: _____ DATE: _____	VILLAGE OF VILLA PARK
REV: RMS DATE: JUL 2004	WATER - 14
DRAWN BY: VV DATE: JAN 2003	

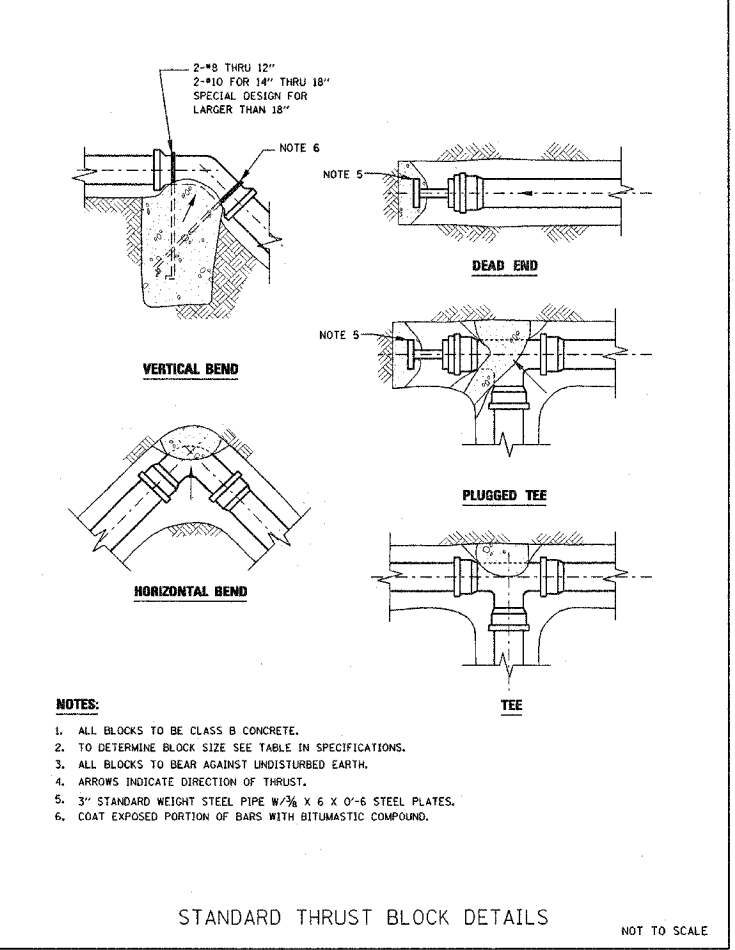

REV: _____ DATE: _____	VILLAGE OF VILLA PARK
REV: RMS DATE: JUL 2004	WATER - 12
DRAWN BY: VV DATE: JAN 2003	

REVISIONS	
NAME	DATE

**Stanley Consultants INC.**  
 859 West Higgins Road  
 Suite 730  
 Chicago, Illinois 60631-2801 Illinois Firm Registration No. 04-00533

VILLAGE OF VILLA PARK, ILLINOIS

**SOUTH VILLA AVENUE  
 UTILITY DETAILS**

SCALE: NONE  
 DATE: 11-NOV-2004

DRAWN BY: E.D.  
 CHECKED BY: J.T.G.