

ROUTE NO.	SECTION	COUNTY	SHEETS	SHEET
F.A.S. 1464	03-00028-03-BR	TAZEWELL	15	8
FED. ROAD DIST. NO.	ILLINOIS	FED. AID PROJECT-		

CONTRACT NO. 89346

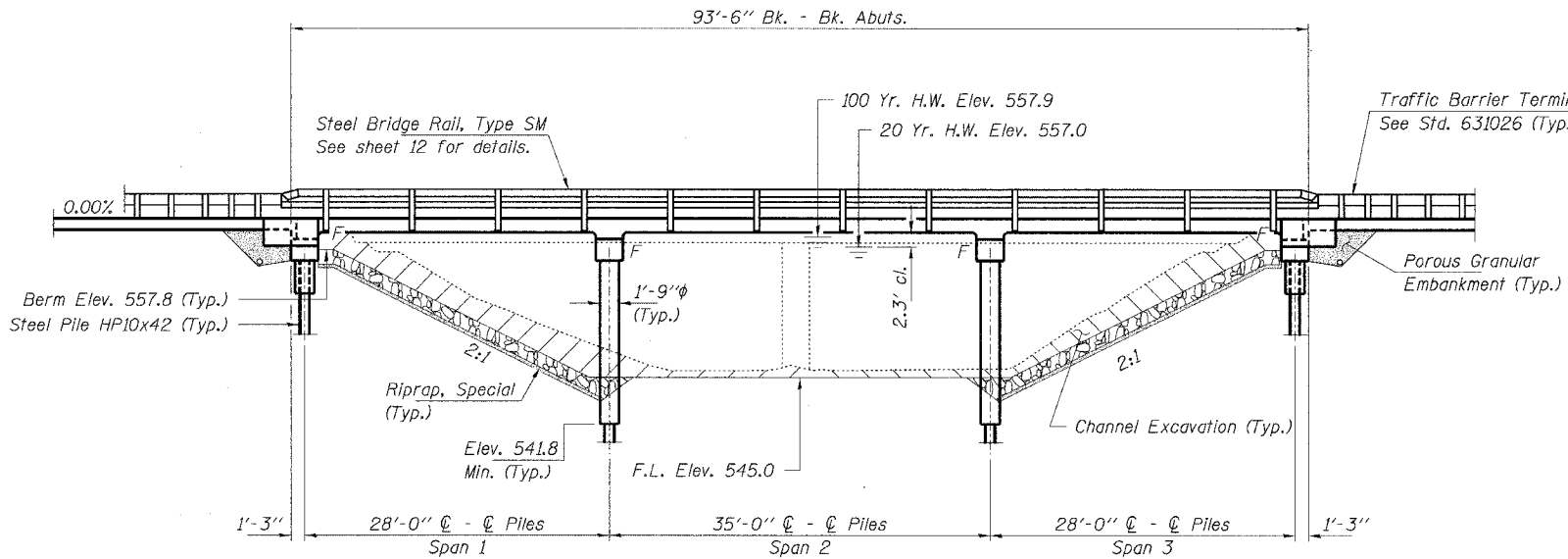

ELEVATION

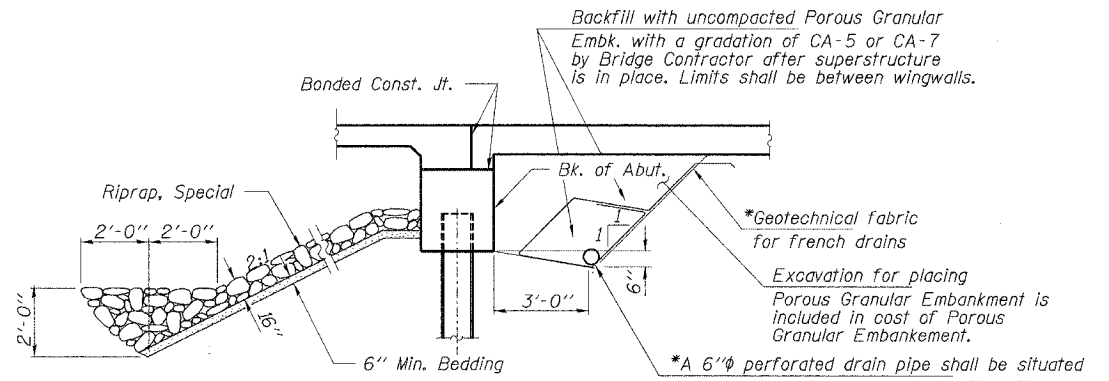

SECTION A-A

Note: See Special Provisions for Riprap, Special.

GENERAL NOTES

Layout of riprap may be varied in the field to suit ground conditions as directed by the Engineer.

Excavation required to construct the abutments shall be considered incidental to Concrete Structures. No additional compensation will be allowed for Structure Excavation.

The Contractor shall drive two steel test piles in permanent locations, one at the North Abutment and one at Pier 1, as directed by the Engineer, before ordering the remainder of the piles.

All proposed construction activity shall be in accordance with Nationwide Permit number 14 of the Department of the Army authorized under Section 404 of the Clean Water Act. The IEPA has issued Section 401 Water Quality Certification for this activity. See Special Provisions for conditions.

Reinforcement bars shall conform to the requirements of AASHTO M31 or M322 Grade 60.

The Contractor shall make allowance for the deflection of forms, shrinkage and settlement of falsework, in addition to allowance for dead load deflection.

Bridge Deck Grooving shall be completed across the bridge deck and bridge approach pavement. Texturing of surfaces shall be done by saw cut grooving.

Protective Coat shall be applied to all exposed areas of the bridge surface and Bridge Approach Pavement.

All construction joints shall be bonded.

See Sheets 14 and 15 for Borings.

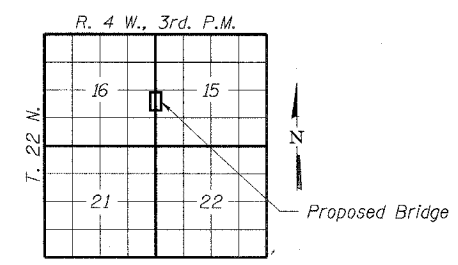

LOCATION SKETCH

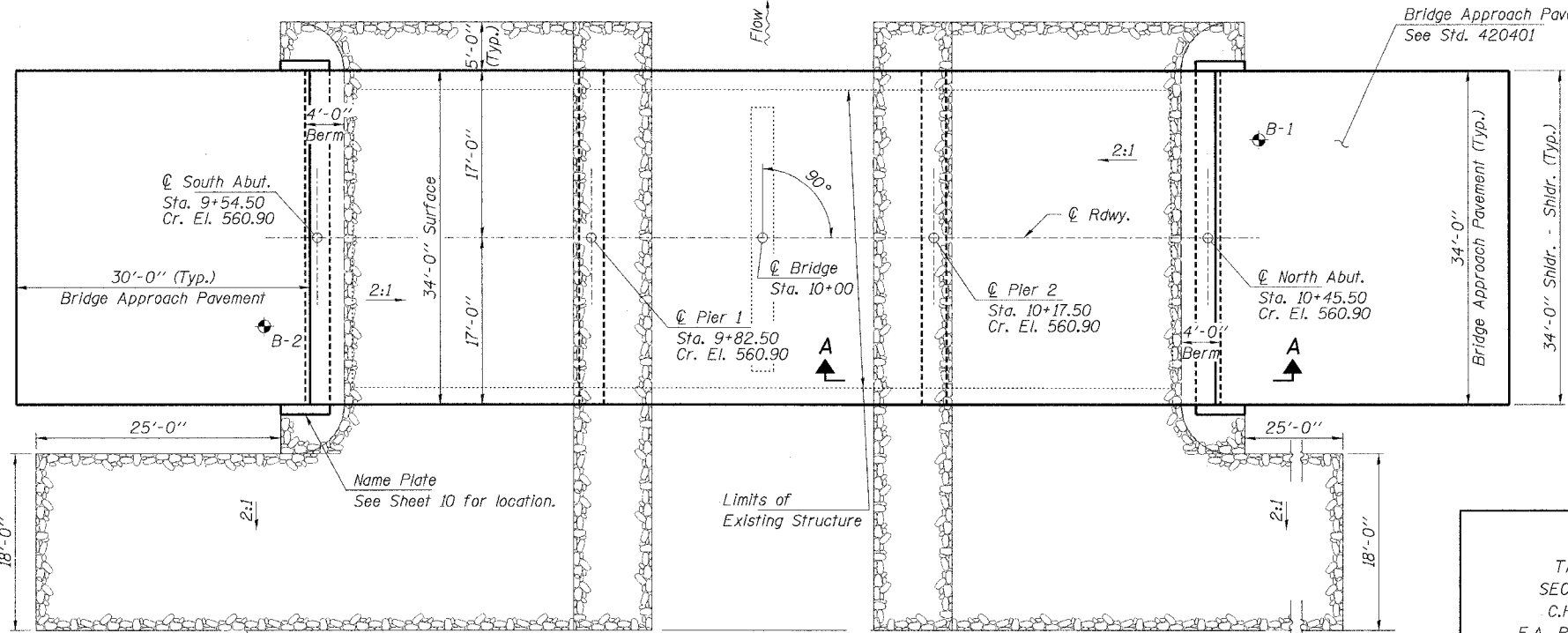

PLAN

CRANE CREEK
BUILT 200_ BY
TAZEWELL COUNTY
SEC. 03-00028-03-BR
C.H. 2 / F.A.S. 1464
F.A. PROJ. BROS-0179 (024)
STR. NO. 090-3241 LOADING HS 20

NAME PLATE
See Std. 515001

I certify that to the best of my knowledge, information and belief, this bridge design is structurally adequate for the design loading shown on the plans. The design is an economical one for the style of structure and complies with requirements of the current "AASHTO Standard Specifications for Highway Bridges".

Steven W. Meggs 10-20-04
ILLINOIS STRUCTURAL NO. 6064 Expires 11-30-06



TOTAL BILL OF MATERIAL

ITEM	UNIT	SUPER	SUB	TOTAL
Concrete Superstructure	Cu. Yd.	156.8		156.8
Concrete Structures	Cu. Yd.		25.1	25.1
Reinforcement Bars, Epoxy Coated	Pound	40,540		40,540
Steel Bridge Rail, Type SM	Foot	191		191
Name Plates	Each		1	1
Riprap, Special	Ton			470
Steel Pile HP10x42	Foot		765	765
Test Pile Steel HP10x42	Each		2	2
Concrete Encasement	Cu. Yd.		15.4	15.4
Protective Coat	Sq. Yd.	375		375
Porous Granular Embankment	Ton		70	70
Bridge Deck Grooving	Sq. Yd.	329		329
Bar Splicers	Each	70		70

WATERWAY DATA

Drainage Area	11.6 Sq. Mi.
Existing Opening	600 Sq. Ft.
Req'd Opening (20 yr)	625 Sq. Ft.
Proposed Opening (20 yr)	625 Sq. Ft.
Design Discharge (20 yr)	2,510 C.F.S.
Created Head (20 yr)	0.0 Ft.
100 Yr. Discharge	3,870 C.F.S.
100 Yr. Created Head	0.0 Ft.

DESIGN STRESSES

$f'_c = 3,500$ p.s.i. Load Factor
 $f_y = 60,000$ p.s.i. (Reinforcement) Design
 $n = 9$

Loading HS 20-44
Design Specifications: 2002 AASHTO & all applicable interims.
25# / Sq. Ft. included in dead load for future wearing surface.

SEISMIC DATA

Seismic Performance Category (SPC) = A
Bedrock Acceleration Coefficient (A) = 0.045g
Site Coefficient (S) = 1.2

GENERAL PLAN AND ELEVATION

F.A.S. 1464 / C.H. 2 / DELAVAN ROAD
SECTION 03-00028-03-BR
TAZEWELL COUNTY
STR. NO. 090-3241 / STATION 10+00

HLR
Rice, Berry and Associates
A Division of Hampton, Lenzini and Renwick, Inc.
Civil & Structural Engineers
801 S. Durkin Drive
Springfield, Illinois 62704
217-546-3400
P.O. Box 1036
DuQuoin, Illinois 62832
618-790-4637
Date: 08/03/04
DESIGNED: T.P.L. CHECKED: S.W.M. DRAWN: D.B.