

ITEM NO.	IDENTIFICATION
1	OUTLET BOX- GALV. 21 CU.IN. (0.000344 CU-M)
2	LAMP HOLDER AND COVER
3	OUTLET BOX COVER
4	RUBBER COVER GASKET
5	REDUCING BUSHING
6	3/4\" (19 mm) CLOSE NIPPLE
7	1/2\" (19 mm) LOCKNUT
8	1/4\" (19 mm) HOLE PLUG
9	SADDLE BRACKET - GALV.
10	6 WATT PAR 38 LED FLOOD LAMP
11	DETECTOR UNIT
12	POST CAP [18 FT. (5.4 m) POST MIN.]

- NOTES:**
- ALL ELECTRICAL ITEMS, EXCEPT ITEMS #2 AND #11 SHALL BE ALUMINUM OR GALVANIZED
  - ITEM #1- OZ/GEDNEY FSX-1-50 OR EQUIVALENT  
ITEM #2- MULBERRY CON-O-SHADE LAMP SHIELD OR EQUIVALENT  
ITEM #9- "BAND-IT" SADDLE BRACKET OR EQUIVALENT
  - WHEN POST MOUNTING IS SPECIFIED, ITEM #9 SHALL NOT BE REQUIRED. THE DETECTION UNIT SHALL BE MOUNTED DIRECTLY ON TOP OF THE CAP BY DRILLING AND TAPPING A 3/4\" (19 mm) HOLE WITH PIPE THREADS. THE POST CAP SHALL EITHER BE SCREWED TO THE TOP OF THE POST OR A MINIMUM OF 3 TIGHTENING SCREWS SHALL BE REQUIRED ON EACH CAP.

FILE NAME =	USER NAME = qureshiya	DESIGNED - DAD	REVISED -
cd:\pw\work\pwsdot\qureshiya\2012\2316\01\2316.dgn		DRAWN - BCK	REVISED -
PLOT SCALE = 50.6394' / IN.		CHECKED - DAD	REVISED -
PLOT DATE = 10/26/2010		DATE - 10-28-09	REVISED -

**STATE OF ILLINOIS  
DEPARTMENT OF TRANSPORTATION**

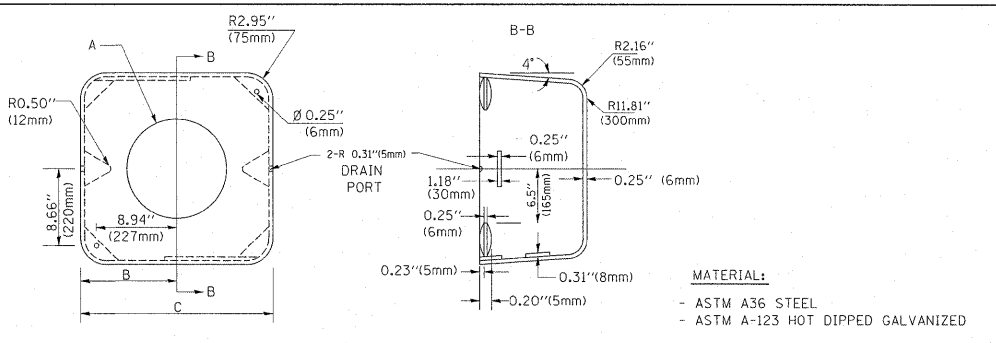

A	B	C	HEIGHT	WEIGHT
VARIABLES	9.5\" (241mm)	19\" (483mm)	7\" (178mm) - 12\" (300mm)	53 lbs (24kg)
VARIABLES	10.75\" (273mm)	21.5\" (546mm)	7\" (178mm) - 12\" (300mm)	68 lbs (31 kg)
VARIABLES	13.0\" (330mm)	26\" (660mm)	7\" (178mm) - 12\" (300mm)	81 lbs (37 kg)
VARIABLES	18.5\" (470mm)	37\" (940mm)	7\" (178mm) - 12\" (300mm)	126 lbs (57 kg)

- SHROUD**
- NOTES:**
- DIMENSION "A" IS EQUAL TO THE DIAMETER OF THE MAST ARM POLE AT THE TOP OF THE SHROUD. THE SHROUD SHALL BE TIGHT TO THE MAST ARM POLE.
  - THE SUPPLIER SHALL VERIFY THE ABOVE DIMENSIONS BASED ON MAST ARM REQUIREMENTS.
  - THE HEIGHT OF THE SHROUD SHALL COVER THE ANCHOR BOLTS, NUTS AND MAST ARM POLE BASE.

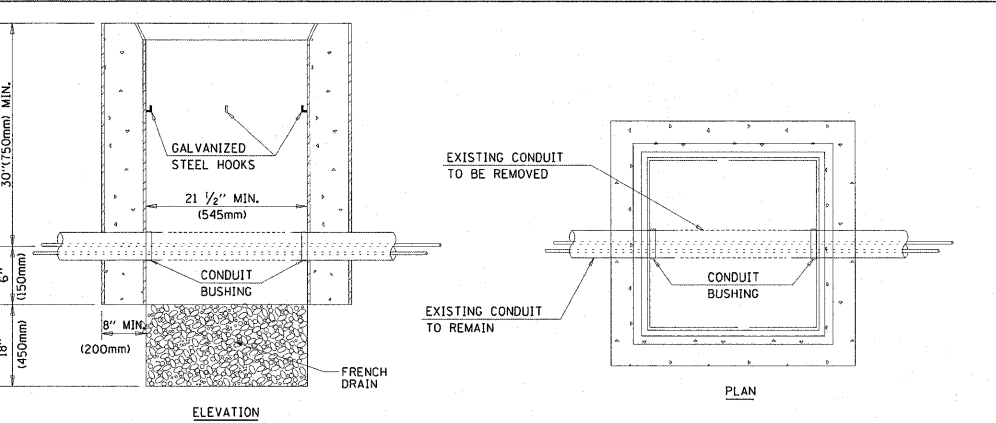
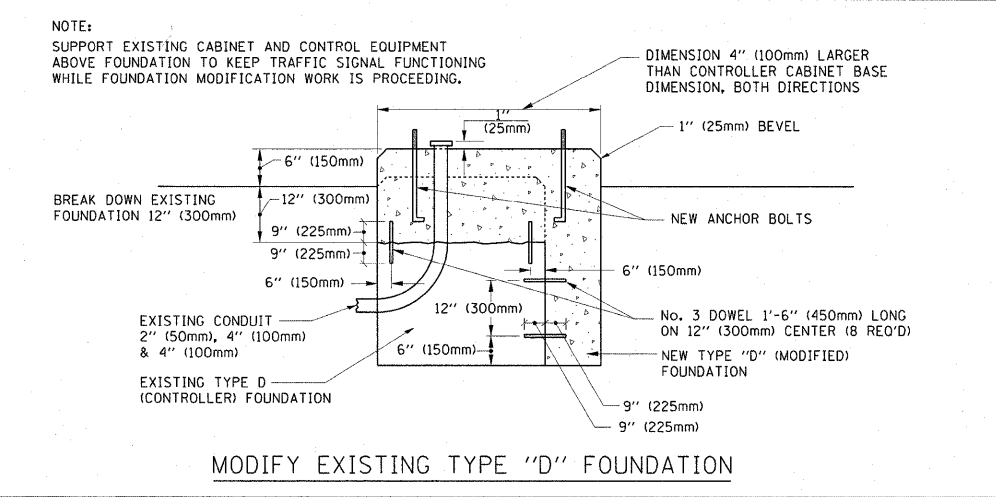

- NOTES:**
- HANDHOLE CONSTRUCTED PER STATE STANDARD 814001.
  - REMOVAL OF THE EXISTING CONDUIT FROM THE HANDHOLE AND THE INSTALLATION OF THE CONDUIT BUSHINGS SHALL BE INCIDENTAL TO THE HANDHOLE.

DISTRICT ONE		F.A.P. RTE.	COUNTY	TOTAL SHEETS	SHEET NO.
STANDARD TRAFFIC SIGNAL DESIGN DETAILS		2010-133-I	WILL	54	49
SCALE: NONE		<b>TS-05</b>		CONTRACT NO. 60F75	
SHEET NO. 4 OF 6 SHEETS	STA.	FED. ROAD DIST. NO. 1 ILLINOIS FED. AID PROJECT			