

F.A.P. RTE.	SECTION	COUNTY	TOTAL SHEETS	SHEET NO.
•	2010-133-1	WILL	55	1
FED. ROAD DIST. NO.	ILLINOIS	CONTRACT NO.	60F75	
• 846/357				

STATE OF ILLINOIS
DEPARTMENT OF TRANSPORTATION
DIVISION OF HIGHWAYS
**PROPOSED
HIGHWAY PLANS**

F.A.P. 846 / 357 (IL 53)
SECTION 2010-133-1
FORKED CREEK TO US 52
GUARDRAIL, SHOULDER RUMBLE STRIPS &
TRAFFIC SIGNAL MODERNIZATION
PROJECT: HSIP-0005(679)
WILL COUNTY
C-91-226-09

FOR INDEX OF SHEETS, SEE SHEET NO. 2

THE IMPROVEMENT IS LOCATED WITHIN THE CITIES OF JOLIET AND WILMINGTON, AND THE VILLAGES OF ELWOOD, ROCKDALE, AND PRESTON HEIGHTS

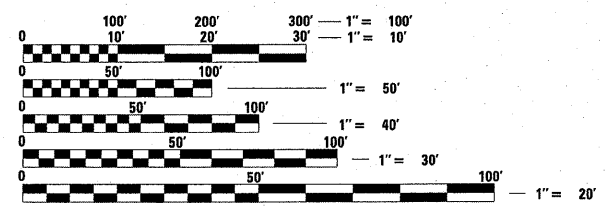
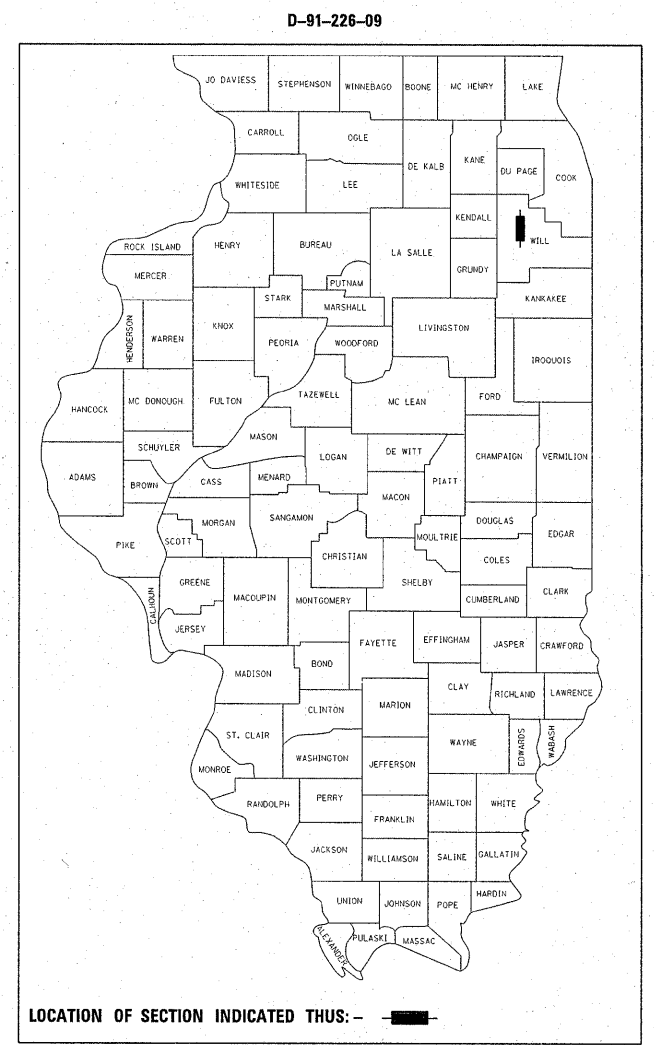

FULL SIZE PLANS HAVE BEEN PREPARED USING STANDARD ENGINEERING SCALES. REDUCED SIZED PLANS WILL NOT CONFORM TO STANDARD SCALES. IN MAKING MEASUREMENTS ON REDUCED PLANS, THE ABOVE SCALES MAY BE USED.

J.U.L.I.E.
JOINT UTILITY LOCATION INFORMATION FOR EXCAVATION
1-800-892-0123
OR 811

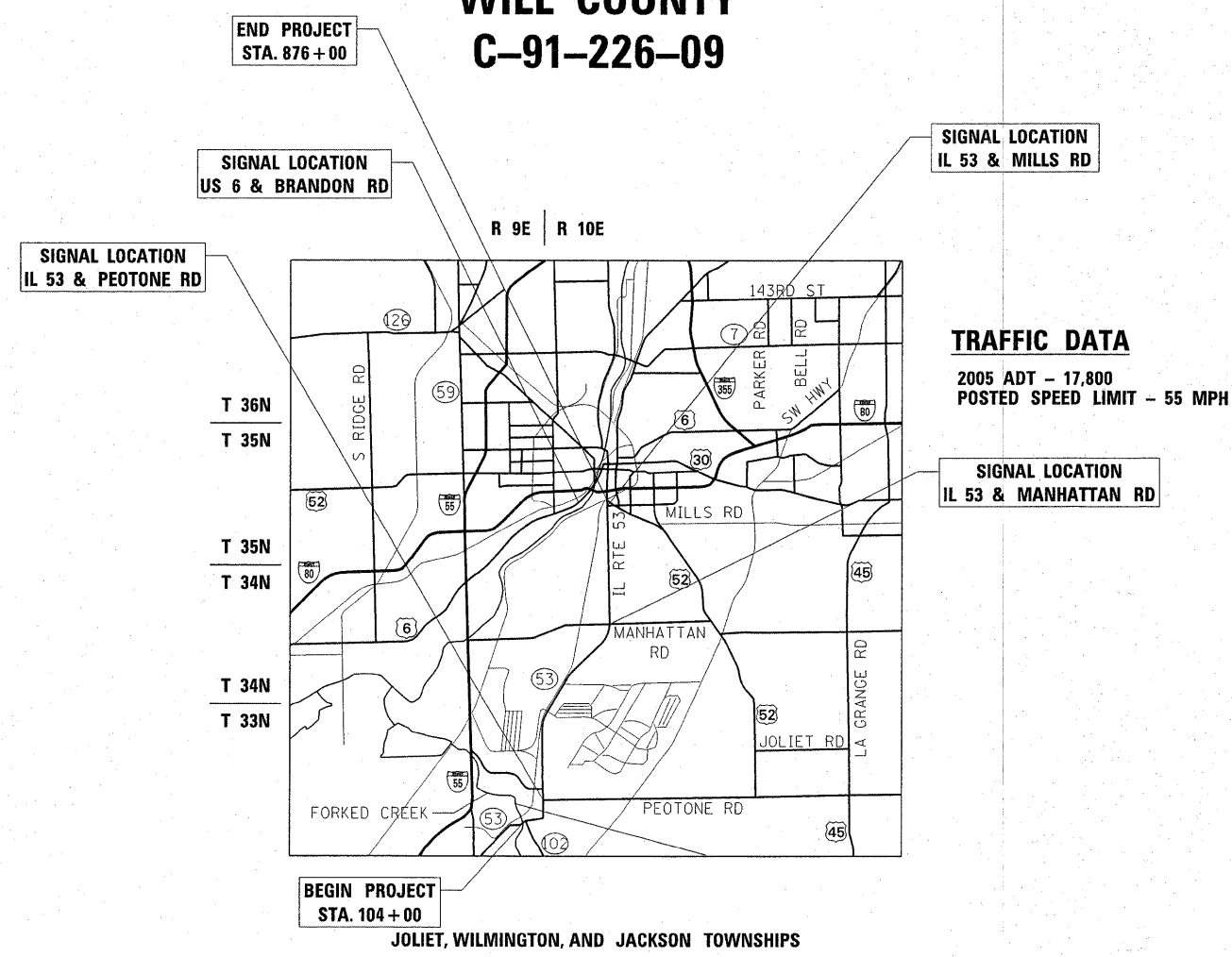

TRAFFIC DATA
2005 ADT - 17,800
POSTED SPEED LIMIT - 55 MPH

PROJECT ENGINEER: JENPAI CHANG (847) 705-4432
PROJECT MANAGER: KEN ENG

CONTRACT NO. 60F75

GROSS AND NET LENGTH OF PROJECT = 77,200 FT = 14.62 MI.

STATE OF ILLINOIS
DEPARTMENT OF TRANSPORTATION
DIVISION OF HIGHWAYS

SUBMITTED OCTOBER 26, 2010

Diane M. O'Keefe
DEPUTY DIRECTOR OF HIGHWAYS, REGION ENGINEER

December 10, 2010
Scott E. Stitt P.E.
acting ENGINEER OF DESIGN AND ENVIRONMENT

December 10, 2010
Christine M. Reed
DIRECTOR OF HIGHWAYS, CHIEF ENGINEER

**PRINTED BY THE AUTHORITY
OF THE STATE OF ILLINOIS**

INDEX OF SHEETS

SHEET NO DESCRIPTION

1	COVER SHEET
2	INDEX OF SHEETS, STATE STANDARDS AND GENERAL NOTES
3-4	SUMMARY OF QUANTITIES
5-8	TYPICAL SECTIONS
9-34	ROADWAY PLANS
35-44	TRAFFIC SIGNAL PLAN SHEETS
45	TRAFFIC SIGNAL DETAIL
46-51	DISTRICT ONE STANDARD TRAFFIC SIGNAL DESIGN DETAILS (TS-05)
52	DISTRICT ONE TYPICAL PAVEMENT MARKINGS (TC-13)
53	ARTERIAL ROAD INFORMATION SIGN (TC-22)
53A	TRAFFIC CONTROL AND PROTECTION FOR SIDE ROADS, INTERSECTIONS, AND DRIVEWAYS (TC-10)
54	SHOULDER RUMBLE STRIP FOR NON-FREEWAY

STATE STANDARDS

000001-00	STANDARD SYMBOLS, ABBREVIATIONS, AND PATTERNS
630001-09	STEEL PLATE BEAM GUARDRAIL
630301-05	SHOULDER WIDENING FOR TYPE 1 (SPECIAL) GUARDRAIL TERMINALS
631011-07	TRAFFIC BARRIER TERMINAL, TYPE 2
631031-09	TRAFFIC BARRIER TERMINAL, TYPE 6
635006-03	REFLECTOR AND TERMINAL MARKER PLACEMENT
635011-02	REFLECTOR MARKER AND MOUNTING DETAIL
642001-01	SHOULDER RUMBLE STRIPS
701311-03	LANE CLOSURE 2L, 2W MOVING OPERATIONS-DAY ONLY
701426-04	LANE CLOSURE, MULTILANE, INTERMITTENT OR MOVING OPER., FOR SPEEDS > 45 MPH
701501-06	URBAN LANE CLOSURE, 2L, 2W, UNDIVIDED
701601-07	URBAN LANE CLOSURE, MULTILANE, 1W OR 2W WITH NONTRAVERSABLE MEDIAN
701701-07	URBAN LANE CLOSURE, MULTILANE INTERSECTION
701901-01	TRAFFIC CONTROL DEVICES
814001-02	HANDHOLES

GENERAL NOTES

BEFORE STARTING ANY EXCAVATION, THE CONTRACTOR SHALL CALL "JULIE" AT 800-892-0123 OR 811 LOCATIONS OF BURIED ELECTRIC, TELEPHONE, AND GAS FACILITIES. (48 HOURS NOTIFICATION IS REQUIRED).

THE CONTRACTOR SHALL COORDINATE CONSTRUCTION ACTIVITIES WITH UTILITY COMPANIES WITHIN THE CITIES OF JOLIET AND WILMINGTON AND THE VILLAGES OF ELWOOD, HOMER GLEN, ROCKDALE AND PRESTON HEIGHTS..

THE CONTRACTOR WILL NOT BE ALLOWED TO SET UP A YARD OR FIELD OFFICE ON STATE PROPERTY WITHOUT WRITTEN PERMISSION FROM THE DEPARTMENT.

BARRICADES: THE CONTRACTOR SHALL PROVIDE AND INSTALL TWO (2) WEIGHTED SANDBAGS ON EACH TYPE I OR TYPE II BARRICADE USED - ONE (1) WEIGHTED SANDBAG ACROSS EACH BOTTOM RAIL.

PERMANENT PAVEMENT MARKINGS SHALL BE THERMOPLASTIC (OF THE EXTRUDED TYPE) AND SHOULD BE PLACED IN ACCORDANCE WITH THE "DISTRICT ONE TYPICAL PAVEMENT MARKINGS" DETAIL. (TC-13)

THE RESIDENTIAL ENGINEER SHALL CONTACT THE TRAFFIC CONTROL SUPERVISOR AT (847) 705-4470 A MINIMUM OF 72 HOURS PRIOR TO INSTALLATION OF ANY TEMPORARY TRAFFIC CONTROL DEVICES.

THE RESIDENTIAL ENGINEER SHALL CONTACT MS. CORA MATHIS, AREA TRAFFIC FIELD ENGINEER AT (847) 715-8428 A MINIMUM OF 72 HOURS PRIOR TO PLACEMENT OF PERMANENT PAVEMENT MARKINGS.

THE CONTRACTOR SHALL DISPOSE OF ALL CUTTINGS AND SWEEP THE SHOULDER CLEAN PRIOR TO OPENING THE TRAFFIC LANE AND SHOULDER TO TRAFFIC. ALL DISPOSAL AND SWEEPING WILL NOT BE PAID FOR SEPARATELY BUT SHALL BE INCLUDED IN THE COST OF SHOULDER RUMBLE STRIPS.

THE CONTRACTOR SHALL RESTRIPE THE EDGE LINES UPON COMPLETION OF THE MILLING OF THE RUMBLE STRIPS. THIS WORK WILL BE PAID FOR AT THE CONTRACT UNIT PRICE FOR THERMOPLASTIC PAVEMENT MARKING - LINE 4".

FILE NAME =	USER NAME = qureshiya	DESIGNED -	REVISED -	STATE OF ILLINOIS DEPARTMENT OF TRANSPORTATION	FAP 846/357 IL 53 FORKED CREEK TO US 52 INDEX OF SHEETS, STATE STANDARDS & GENERAL NOTES	F.A.P. RTE.	SECTION	COUNTY	TOTAL SHEETS	SHEET NO.	
ci:\pwork\pwidot\qureshiya\0212316\DI22609-sht-plan.dgn		DRAWN -	REVISED -		SCALE: NONE	SHEET NO. 1 OF 1 SHEETS	• 846/357	2010-133-1	WILL	54	2
		PLOT SCALE = 50.0000' / IN.	REVISED -		STA.	TO STA.	ILLINOIS FED. AID PROJECT				
		PLOT DATE = 10/28/2010	REVISED -		CONTRACT NO. 60F75						

SUMMARY OF QUANTITIES			URBAN 90% FED. 10% STATE TOTAL QUANTITIES	CONSTRUCTION TYPE CODE					SUMMARY OF QUANTITIES			URBAN 90% FED. 10% STATE TOTAL QUANTITIES	CONSTRUCTION TYPE CODE				
CODE NO	ITEM	UNIT		0005 IL 53 ROADWAY	FAP 846 0021 IL 53 AT PEOTONE	FAP 846 0021 IL 53 AT MANHATTAN	FAP 846 0021 IL 53 AT MILLS	FAP 357 0021 US 6 AT BRANDON	CODE NO	ITEM	UNIT		0005 IL 53 ROADWAY	FAP 846 0021 IL 53 AT PEOTONE	FAP 846 0021 IL 53 AT MANHATTAN	FAP 846 0021 IL 53 AT MILLS	FAP 357 0021 US 6 AT BRANDON
20201200	REMOVAL AND DISPOSAL OF UNSUITABLE MATERIAL	CU YD	38300	38300					*87301225	ELECTRIC CABLE IN CONDUIT, SIGNAL NO. 14 3C	FOOT	80	80				
20400800	FURNISHED EXCAVATION	CU YD	10	10					*87301245	ELECTRIC CABLE IN CONDUIT, SIGNAL NO. 14 5C	FOOT	2950	1500	550	900		
31101200	SUBBASE GRANULAR MATERIAL, TYPE B 4"	SO YD	113550	113550					*87301255	ELECTRIC CABLE IN CONDUIT, SIGNAL NO. 14 7C	FOOT	80	80				
35501308	HOT-MIX ASPHALT BASE COURSE, 6"	SO YD	84100	84100					*87301805	ELECTRIC CABLE IN CONDUIT, SERVICE, NO. 6 2 C	FOOT	300	200	100			
40600895	CONSTRUCTING TEST STRIP	EACH	1	1					*87502480	TRAFFIC SIGNAL POST, GALVANIZED STEEL 14 FT.	EACH	2	2				
40603340	HOT-MIX ASPHALT SURFACE COURSE, MIX "D", N70	TON	10430	10430					*87502500	TRAFFIC SIGNAL POST, GALVANIZED STEEL 16 FT.	EACH	2	2				
44000100	PAVEMENT REMOVAL	SO YD	12600	12600					*87700180	STEEL MAST ARM ASSEMBLY AND POLE, 28 FT.	EACH	2	2				
44000159	HOT-MIX ASPHALT SURFACE REMOVAL, 2 1/2"	SO YD	37225	37225					*87700280	STEEL MAST ARM ASSEMBLY AND POLE, 48 FT.	EACH	1		1			
48101200	AGGREGATE SHOULDERS, TYPE B	TON	22550	22550					*87800115	CONCRETE FOUNDATION, TYPE A	EACH	4	4				
48102100	AGGREGATE WEDGE SHOULDER, TYPE B	TON	22550	22550				* * SPECIALTY ITEMS	*87800400	CONCRETE FOUNDATION, TYPE E 30-INCH DIAMETER	FOOT	20	20				
*63000001	STEEL PLATE BEAM GUARDRAIL, TYPE A, 6 FOOT POSTS	FOOT	700	700					*87800415	CONCRETE FOUNDATION, TYPE E 36-INCH DIAMETER	FOOT	13		13			
*63000003	STEEL PLATE BEAM GUARDRAIL, TYPE A, 9 FOOT POSTS	FOOT	3525	3525					*87900200	DRILL EXISTING HANDHOLE	EACH	7	6		1		
*63100045	TRAFFIC BARRIER TERMINAL, TYPE 2	EACH	7	7					*88030020	SIGNAL HEAD, LED, 1-FACE, 3-SECTION, MAST-ARM MOUNTED	EACH	18	6	8	4		
*63100085	TRAFFIC BARRIER TERMINAL, TYPE 6	EACH	2	2					*88030050	SIGNAL HEAD, LED, 1-FACE, 3-SECTION, BRACKET MOUNTED	EACH	3	2		1		
*63100167	TRAFFIC BARRIER TERMINAL, TYPE 1 (SPECIAL) TANGENT	EACH	29	29					*88030100	SIGNAL HEAD, LED, 1-FACE, 5-SECTION, BRACKET MOUNTED	EACH	6	2	4			
63200310	GUARDRAIL REMOVAL	FOOT	2900	2900					*88030110	SIGNAL HEAD, LED, 1-FACE, 5-SECTION, MAST-ARM MOUNTED	EACH	7	2		5		
64200105	SHOULDER RUMBLE STRIPS	FOOT	239650	239650					*88030210	SIGNAL HEAD, LED, 2-FACE, 3-SECTION, BRACKET MOUNTED	EACH	3		2	1		
X6640300	CHAIN LINK FENCE REMOVAL	FOOT	55	55					*88030240	SIGNAL HEAD, LED, 2-FACE, 1-3 SECTION, 1-5 SECTION, BRACKET MOUNTED	EACH	2			2		
67000400	ENGINEER'S FIELD OFFICE, TYPE A	CAL MO	5	5					*88200210	TRAFFIC SIGNAL BACKPLATE, LOUVERED, ALUMINUM	EACH	22	8	8	6		
67100100	MOBILIZATION	L SUM	1	1					*89501400	RELOCATE EXISTING EMERGENCY VEHICLE PRIORITY SYSTEM, DETECTOR UNIT	EACH	1	1				
70102620	TRAFFIC CONTROL AND PROTECTION, STANDARD 701501	L SUM	1	1					*89502300	REMOVE ELECTRIC CABLE FROM CONDUIT	FOOT	1420	820		600		
70102630	TRAFFIC CONTROL AND PROTECTION, STANDARD 701601	L SUM	1	1					*89502375	REMOVE EXISTING TRAFFIC SIGNAL EQUIPMENT	EACH	3	1	1	1		
70102635	TRAFFIC CONTROL AND PROTECTION, STANDARD 701701	L SUM	1	1					*89502385	REMOVE EXISTING CONCRETE FOUNDATION	EACH	8	6		2		
*78000200	THERMOPLASTIC PAVEMENT MARKING - LINE 4"	FOOT	250000	250000					*X2020110	GRADING SHD SHAPING SHOULDERS	UNIT	80	80				
*78000650	THERMOPLASTIC PAVEMENT MARKING - LINE 24"	FOOT	360		95	165	100		X4060826	POLYMERIZED LEVELING BINDER (MACHINE METHOD), IL-4, 75, N50	TON	6520	6520				
*78200410	GUARDRAIL MARKERS, TYPE A	EACH	80	80					50105220	PIPE CULVERT REMOVAL	FOOT	50	50				
*78201000	TERMINAL MARKER - DIRECT APPLIED	EACH	28	28													
*81000700	CONDUIT IN TRENCH, 2 1/2" DIA., GALVANIZED STEEL	FOOT	64		54		10										
*81900200	TRENCH AND BACKFILL FOR ELECTRICAL WORK	FOOT	40		30		10										
*85000200	MAINTENANCE OF EXISTING TRAFFIC SIGNAL INSTALLATION	EACH	3		1	1	1										

SUMMARY OF QUANTITIES			URBAN 90% FED. 10% STATE TOTAL QUANTITIES	CONSTRUCTION TYPE CODE					SUMMARY OF QUANTITIES			TOTAL QUANTITIES	CONSTRUCTION TYPE CODE				
CODE NO	ITEM	UNIT		0005 IL 53 ROADWAY	FAP 846 0021 IL 53 AT PEOTONE	FAP 846 0021 IL 53 AT MANHATTAN	FAP 846 0021 IL 53 AT MILLS	FAP 357 0021 US 6 AT BRANDON	CODE NO	ITEM	UNIT		ROADWAY				
• X8050015	SERVICE INSTALLATION - POLE MOUNTED	EACH	2		1	1											
• X8140074	GROUNDING EXISTING HANDHOLE FRAME AND COVER	EACH	16		9		7										
• X8620020	UNINTERRUPTIBLE POWER SUPPLY	EACH	3		1	1	1										
• X8730027	ELECTRIC CABLE IN CONDUIT, GROUNDING, NO. 6 1C	FOOT	1750		900	100	750										
• X8730250	ELECTRIC CABLE IN CONDUIT NO. 20 3/C, TWISTED, SHIELDED	FOOT	80		80												
• X8807665	SIGNAL HEAD ,LED, 1-SECTION, POST MOUNTED, RETROFIT	EACH	1					1									
• X8950210	REBUILD EXISTING HANDHOLE TO HEAVY-DUTY HANDHOLE	EACH	1		1												
Z0002005	ATTENUATOR BASE	SO YD	52	52													
Z0030030	IMPACT ATTENUATORS (FULLY REDIRECTIVE, NARROW), TEST LEVEL 3	EACH	1	1													
Z0030150	IMPACT ATTENUATORS (NON-REDIRECTIVE), TEST LEVEL 3	EACH	1	1													
Z0030850	TEMPORARY INFORMATION SIGNING	SO FT	52	52													
Z0013798	CONSTRUCTION LAYOUT	L SUM	1	1													
* SPECIALTY ITEMS																	

FILE NAME =	USER NAME = qureshtya	DESIGNED -	REVISED -
c:\pw_wor\qureshtya\0212316\022609-stt-pla.dgn		DRAWN -	REVISED -
	PLOT SCALE = 50.0000' / 1" =	CHECKED -	REVISED -
	PLOT DATE = 11/3/2010	DATE -	REVISED -

**STATE OF ILLINOIS
DEPARTMENT OF TRANSPORTATION**

SUMMARY OF QUANTITIES			
SCALE: NONE	SHEET NO. 1 OF 1 SHEETS	STA.	TO STA.

F.A.P. RTE.	SECTION	COUNTY	TOTAL SHEETS	SHEET NO.
• 846/357	2010-133-1	WILL	54	4
FED. ROAD DIST. NO. 1 ILLINOIS FED. AID PROJECT			CONTRACT NO. 60F75	

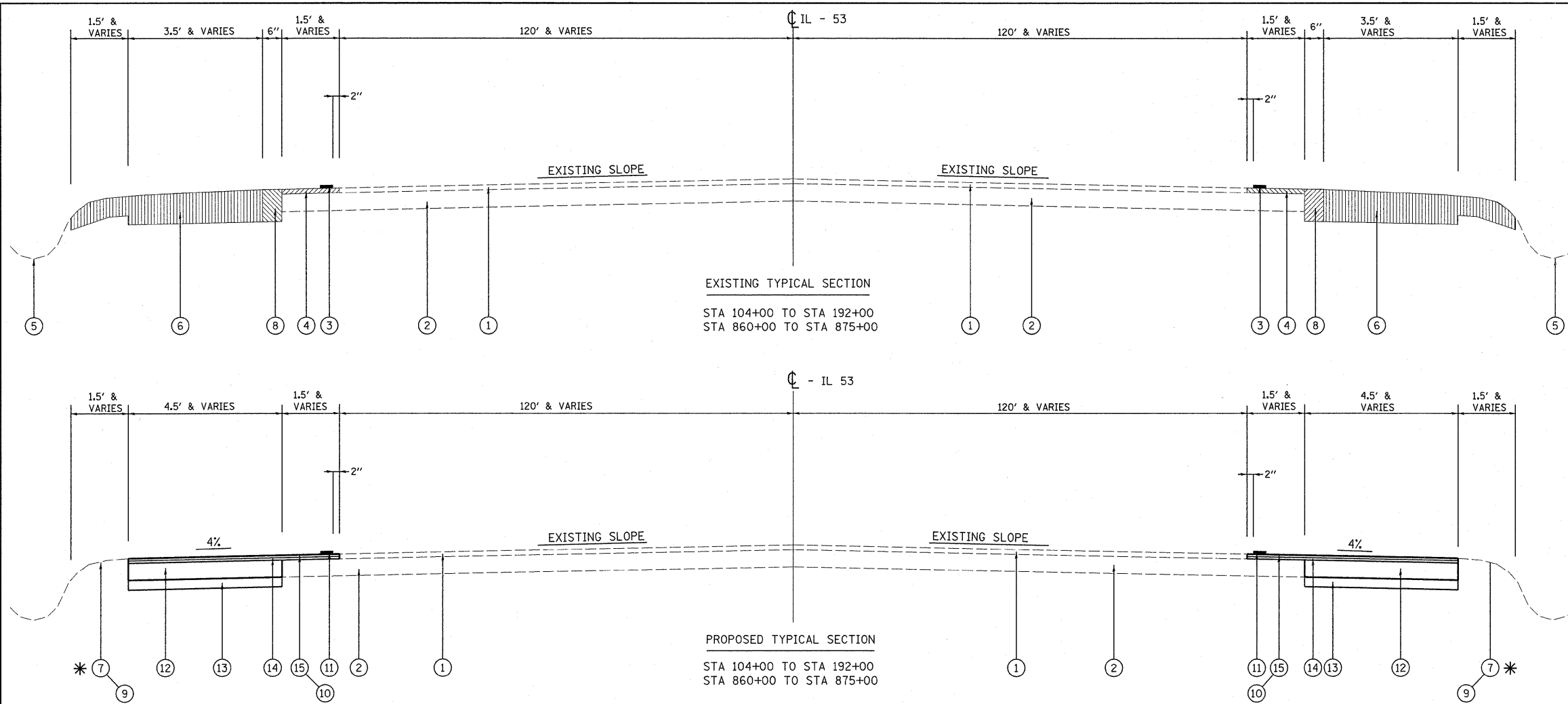

HOT-MIX ASPHALT MIXTURE REQUIREMENTS	
MIXTURE TYPE	AIR VOIDS(%)
HMA SHOULDER	
HOT-MIX ASPHALT SURFACE COURSE, MIX "D", N70 (IL-9.5MM), 1 1/2"	4% @ 70 GYR.
POLYMERIZED LEVELING BINDER (MACHINE METHOD), IL-4.75, N50, 1"	4% @ 50 GYR.
HOT-MIX ASPHALT SHOULDER, 6" (HMA BINDER, IL-19MM)	2% @ 30 GYR.

NOTE: THE UNIT WEIGHT USED TO CALCULATE ALL HOT-MIX ASPHALT SURFACE MIXTURE QUANTITIES IS 112 LBS/SQ YD/IN.

"THE "AC TYPE" FOR POLYMERIZED HMA MIXES SHALL BE "SBS/SBR PG 70-22" AND FOR NON-POLYMERIZED HMA THE "AC TYPE" SHALL BE "PG 64-22" UNLESS MODIFIED BY DISTRICT ONE SPECIAL PROVISIONS."
 "FOR "PERCENT OF RAP" SEE DISTRICT ONE SPECIAL PROVISIONS."

NOTE:

* AGGREGATE SHOULDER, TYPE B SHALL BE PLACED IN GAPS BETWEEN THE PROPOSED SHOULDER AND THE EXISTING OR PROPOSED GUARDRAIL. THE THICKNESS AT THE AGGREGATE SHALL BE 4 INCHES OR AS DIRECTED BY THE ENGINEER.

BETWEEN STA 267+00 TO STA 282+00 AND STA 600+00 TO STA 615+00 ROADWORK WILL BE LIMITED TO PROPOSED "SHOULDER RUMBLE STRIP", THE OUTSIDE AND INSIDE LANE LINES SHALL ALSO BE RE-STRIPED WITH "THERMOPLASTIC PAVEMENT MARKING - LINE, 4 INCHES"

LEGEND

- ① EXISTING HOT-MIX ASPHALT SURFACE
- ② EXISTING P.C.C. BASE COURSE
- ③ EXISTING PAVEMENT MARKING LINE, 4"
- ④ EXISTING HOT-MIX ASPHALT SURFACE REMOVAL, 2 1/2"
- ⑤ EXISTING AGGREGATE OR GRASS SHOULDER
- ⑥ PROPOSED REMOVAL AND DISPOSAL OF UNSUITABLE MATERIAL
- ⑦ PROPOSED AGGREGATE WEDGE SHOULDER, TYPE B
- ⑧ PROPOSED PAVEMENT REMOVAL
- ⑨ PROPOSED GRADING AND SHAPING SHOULDERS (WHERE NECESSARY)
- ⑩ PROPOSED SHOULDER RUMBLE STRIPES, (16" WIDE)
- ⑪ PROPOSED THERMOPLASTIC PAVEMENT MARKING LINE, 4"
- ⑫ PROPOSED HOT-MIX ASPHALT BASE COURSE, 6" (IN 2 LIFTS)
- ⑬ PROPOSED SUBBASE GRANULAR MATERIAL TYPE B, 4"
- ⑭ PROPOSED POLYMERIZED LEVELING BINDER (MM), IL-4.75, N50, 1"
- ⑮ PROPOSED HMA SURFACE COURSE, MIX "D", N70, 1 1/2"

FILE NAME =	USER NAME = qureshiga	DESIGNED -	REVISED -
ca\pw_work\pawdot\qureshiga\d0212316\0122609-sh1-plen.dgn		DRAWN -	REVISED -
	PLOT SCALE = 50.0000 ' / IN.	CHECKED -	REVISED -
	PLOT DATE = 10/28/2010	DATE -	REVISED -

STATE OF ILLINOIS
DEPARTMENT OF TRANSPORTATION

TYPICAL SECTIONS

SCALE: NONE SHEET NO. 1 OF 4 SHEETS STA. TO STA.

F.A.P. RTE.	SECTION	COUNTY	TOTAL SHEETS	SHEET NO.
*	2010-133-1	WILL	54	5
* 846/357			CONTRACT NO. 60F75	
ILLINOIS FED. AID PROJECT				

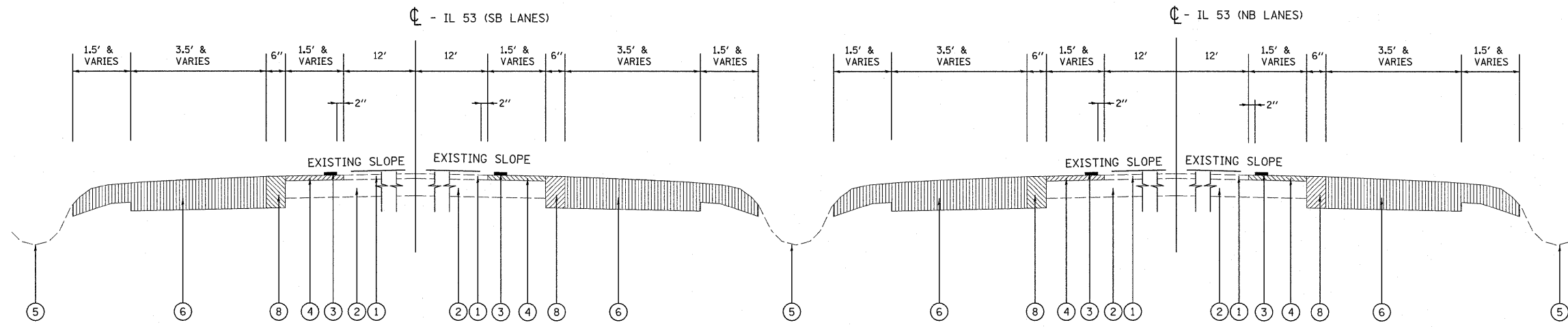

EXISTING TYPICAL SECTION
 STA 192+00 TO STA 267+00
 STA 282+00 TO STA 586+00

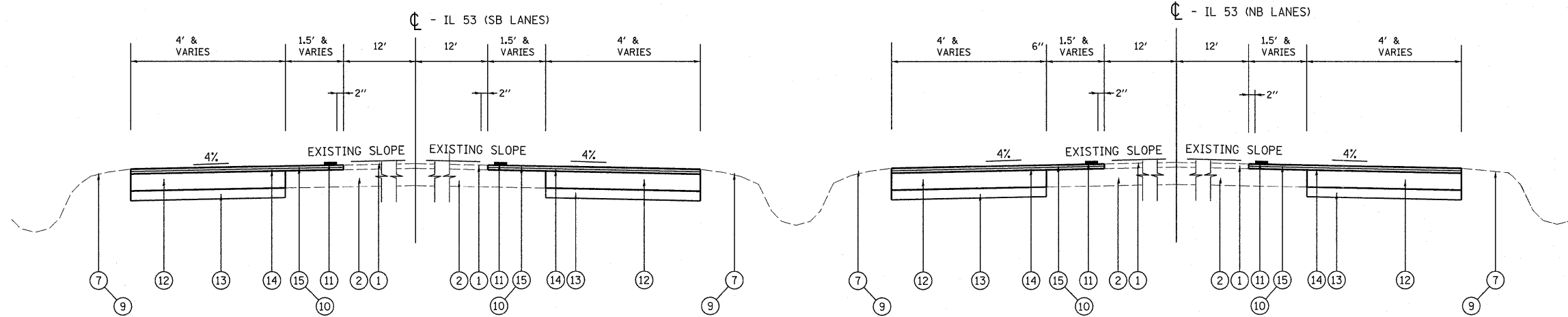

PROPOSED TYPICAL SECTION
 STA 192+00 TO STA 267+00
 STA 282+00 TO STA 586+00

LEGEND

- ① EXISTING HOT-MIX ASPHALT SURFACE
- ② EXISTING P.C.C. BASE COURSE
- ③ EXISTING PAVEMENT MARKING LINE, 4"
- ④ EXISTING HOT-MIX ASPHALT SURFACE REMOVAL, 2 1/2"
- ⑤ EXISTING AGGREGATE OR GRASS SHOULDER
- ⑥ PROPOSED REMOVAL AND DISPOSAL OF UNSUITABLE MATERIAL
- ⑦ PROPOSED AGGREGATE WEDGE SHOULDER, TYPE B
- ⑧ PROPOSED PAVEMENT REMOVAL
- ⑨ PROPOSED GRADING AND SHAPING SHOULDERS (WHERE NECESSARY)
- ⑩ PROPOSED SHOULDER RUMBLE STRIPES, (16" WIDE)
- ⑪ PROPOSED THERMOPLASTIC PAVEMENT MARKING LINE, 4"
- ⑫ PROPOSED HOT-MIX ASPHALT BASE COURSE, 6" (IN 2 LIFTS)
- ⑬ PROPOSED SUBBASE GRANULAR MATERIAL TYPE B, 4"
- ⑭ PROPOSED POLYMERIZED LEVELING BINDER (MM), IL-4.75, N50, 1"
- ⑮ PROPOSED HMA SURFACE COURSE, MIX "D", N70, 1 1/2"

NOTE:

BETWEEN STA 267+00 TO STA 282+00 AND STA 600+00 TO STA 615+00 ROADWORK WILL BE LIMITED TO PROPOSED "SHOULDER RUMBLE STRIP". THE OUTSIDE AND INSIDE LANE LINES SHALL ALSO BE RE-STRIPED WITH "THERMOPLASTIC PAVEMENT MARKING - LINE, 4 INCHES"

FILE NAME =	USER NAME = qureshiya	DESIGNED -	REVISED -	STATE OF ILLINOIS DEPARTMENT OF TRANSPORTATION	TYPICAL SECTIONS		F.A.P. RTE.	SECTION	COUNTY	TOTAL SHEETS	SHEET NO.	
c:\pw_work\pawdot\qureshiya\0212316\012609-sht-plen.dgn		DRAWN -	REVISED -		SCALE: NONE	SHEET NO. 2 OF 4 SHEETS	STA.	TO STA.	2010-133-1	WILL	54	6
		CHECKED -	REVISED -						846/357			
		DATE -	REVISED -									
								ILLINOIS FED. AID PROJECT				CONTRACT NO. 60F75

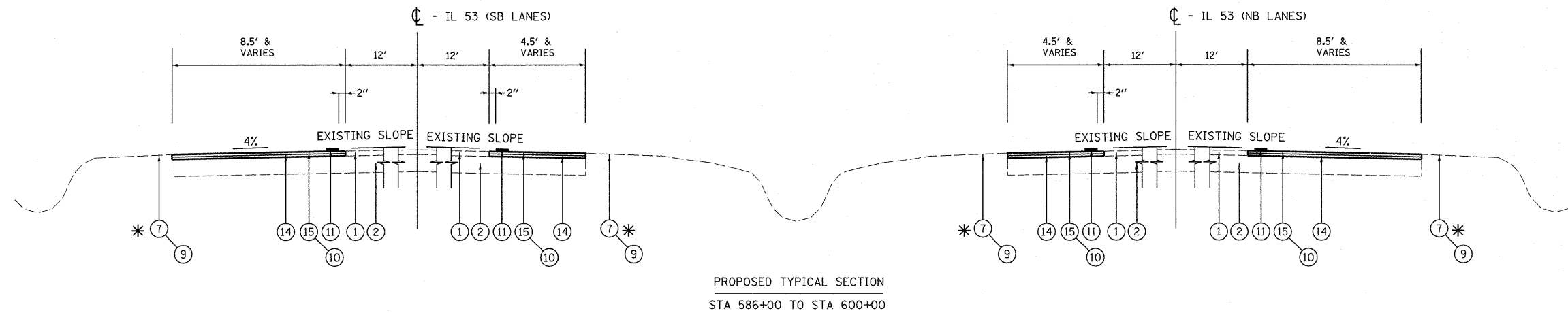
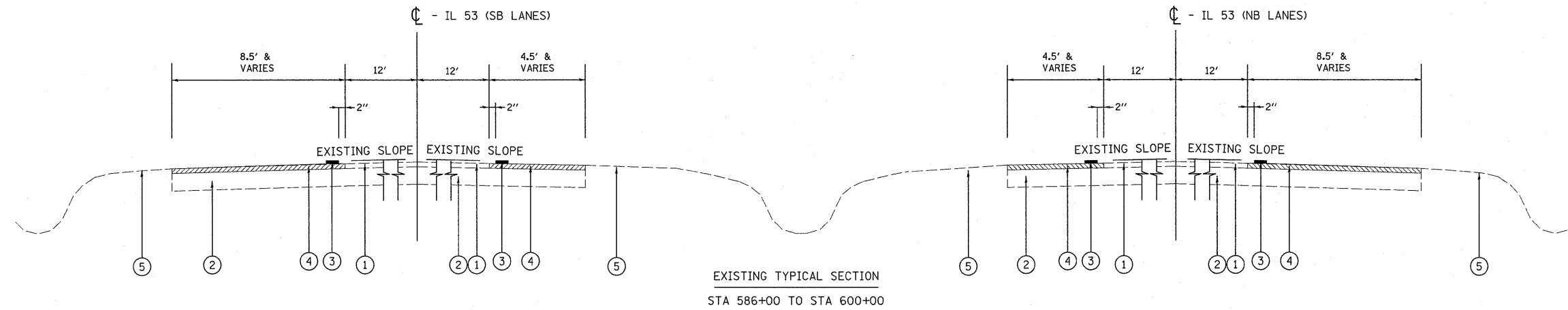

LEGEND

- ① EXISTING HOT-MIX ASPHALT SURFACE
- ② EXISTING P.C.C. BASE COURSE
- ③ EXISTING PAVEMENT MARKING LINE, 4"
- ④ EXISTING HOT-MIX ASPHALT SURFACE REMOVAL, 2 1/2"
- ⑤ EXISTING AGGREGATE OR GRASS SHOULDER
- ⑥ PROPOSED REMOVAL AND DISPOSAL OF UNSUITABLE MATERIAL
- ⑦ PROPOSED AGGREGATE WEDGE SHOULDER, TYPE B
- ⑧ PROPOSED PAVEMENT REMOVAL
- ⑨ PROPOSED GRADING AND SHAPING SHOULDERS (WHERE NECESSARY)
- ⑩ PROPOSED SHOULDER RUMBLE STRIPES, (16" WIDE)
- ⑪ PROPOSED THERMOPLASTIC PAVEMENT MARKING LINE, 4"
- ⑫ PROPOSED HOT-MIX ASPHALT BASE COURSE, 6" (IN 2 LIFTS)
- ⑬ PROPOSED SUBBASE GRANULAR MATERIAL TYPE B, 4"
- ⑭ PROPOSED POLYMERIZED LEVELING BINDER (MM), IL-4.75, N50, 1"
- ⑮ PROPOSED HMA SURFACE COURSE, MIX "D", N70, 1 1/2"

NOTE:

* AGGREGATE SHOULDER, TYPE B SHALL BE PLACED IN GAPS BETWEEN THE PROPOSED SHOULDER AND THE EXISTING OR PROPOSED GUARDRAIL. THE THICKNESS AT THE AGGREGATE SHALL BE 4 INCHES OR AS DIRECTED BY THE ENGINEER.

BETWEEN STA 267+00 TO STA 282+00 AND STA 600+00 TO STA 615+00 ROADWORK WILL BE LIMITED TO PROPOSED "SHOULDER RUMBLE STRIP". THE OUTSIDE AND INSIDE LANE LINES SHALL ALSO BE RE-STRIPED WITH "THERMOPLASTIC PAVEMENT MARKING - LINE, 4 INCHES"

FILE NAME =	USER NAME = qureshiya	DESIGNED -	REVISED -	STATE OF ILLINOIS DEPARTMENT OF TRANSPORTATION	TYPICAL SECTIONS			F.A.P. RTE.	SECTION	COUNTY	TOTAL SHEETS	SHEET NO.
c:\pw_work\pwin\dot\qureshiya\d0212316\012	689-shi-plen.dgn	DRAWN -	REVISED -		SCALE: NONE	SHEET NO. 3 OF 4 SHEETS	STA. TO STA.	• 2010-133-1	WILL	54	7	
	PLOT SCALE = 50.0000' / IN.	CHECKED -	REVISED -					• 846/357				CONTRACT NO. 60F75
	PLOT DATE = 10/28/2010	DATE -	REVISED -					ILLINOIS FED. AID PROJECT				

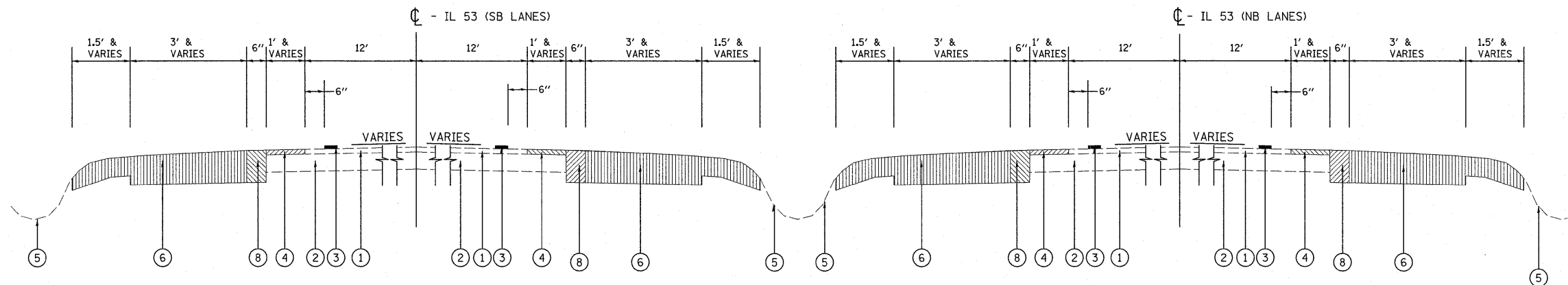

EXISTING TYPICAL SECTION
STA 615+00 TO STA 860+00

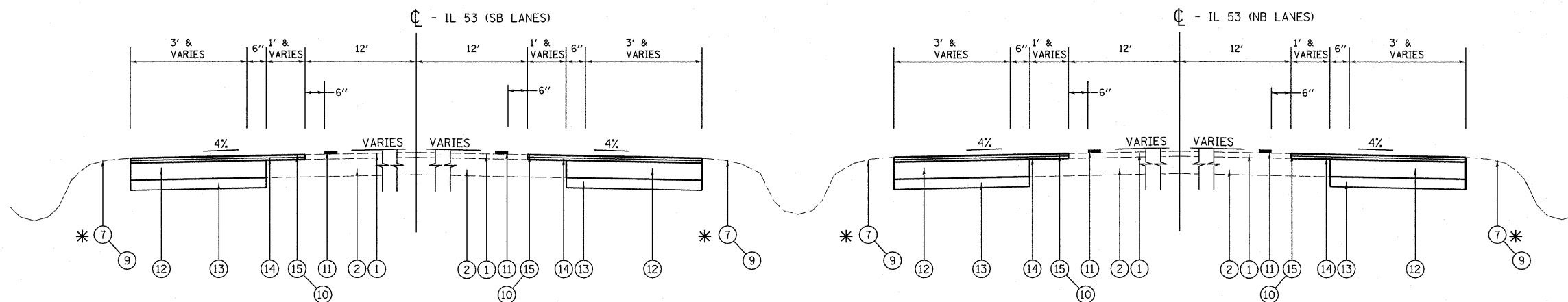

PROPOSED TYPICAL SECTION
STA 615+00 TO STA 860+00

LEGEND

- ① EXISTING HOT-MIX ASPHALT SURFACE
- ② EXISTING P.C.C. BASE COURSE
- ③ EXISTING PAVEMENT MARKING LINE, 4"
- ④ EXISTING HOT-MIX ASPHALT SURFACE REMOVAL, 2 1/2"
- ⑤ EXISTING AGGREGATE OR GRASS SHOULDER
- ⑥ PROPOSED REMOVAL AND DISPOSAL OF UNSUITABLE MATERIAL
- ⑦ PROPOSED AGGREGATE WEDGE SHOULDER, TYPE B
- ⑧ PROPOSED PAVEMENT REMOVAL
- ⑨ PROPOSED GRADING AND SHAPING SHOULDERS (WHERE NECESSARY)
- ⑩ PROPOSED SHOULDER RUMBLE STRIPES, (16" WIDE)
- ⑪ PROPOSED THERMOPLASTIC PAVEMENT MARKING LINE, 4"
- ⑫ PROPOSED HOT-MIX ASPHALT BASE COURSE, 6" (IN 2 LIFTS)
- ⑬ PROPOSED SUBBASE GRANULAR MATERIAL TYPE B, 4"
- ⑭ PROPOSED POLYMERIZED LEVELING BINDER (MM), IL-4.75, N50, 1"
- ⑮ PROPOSED HMA SURFACE COURSE, MIX "D", N70, 1 1/2"

NOTE:

* AGGREGATE SHOULDER, TYPE B SHALL BE PLACED IN GAPS BETWEEN THE PROPOSED SHOULDER AND THE EXISTING OR PROPOSED GUARDRAIL. THE THICKNESS AT THE AGGREGATE SHALL BE 4 INCHES OR AS DIRECTED BY THE ENGINEER.

BETWEEN STA 267+00 TO STA 282+00 AND STA 600+00 TO STA 615+00 ROADWORK WILL BE LIMITED TO PROPOSED "SHOULDER RUMBLE STRIP". THE OUTSIDE AND INSIDE LANE LINES SHALL ALSO BE RE-STRIPED WITH "THERMOPLASTIC PAVEMENT MARKING - LINE, 4 INCHES"

FILE NAME =	USER NAME = qureshiya	DESIGNED -	REVISED -	STATE OF ILLINOIS DEPARTMENT OF TRANSPORTATION	TYPICAL SECTIONS			F.A.P. RTE.	SECTION	COUNTY	TOTAL SHEETS	SHEET NO.	
ci\pw_work\pwidot\qureshiya\d0212316\012	609-sht-plan.dgn	DRAWN -	REVISED -		SCALE: NONE	SHEET NO. 4 OF 4 SHEETS	STA.	TO STA.	2010-133-I	WILL	54	8	
	PLOT SCALE = 50.0000' / IN.	CHECKED -	REVISED -						* 846/357				CONTRACT NO. 60F75
	PLOT DATE = 10/28/2010	DATE -	REVISED -							ILLINOIS FED. AID PROJECT			



**BEGIN IMPROVEMENT
STA. 104 + 00**

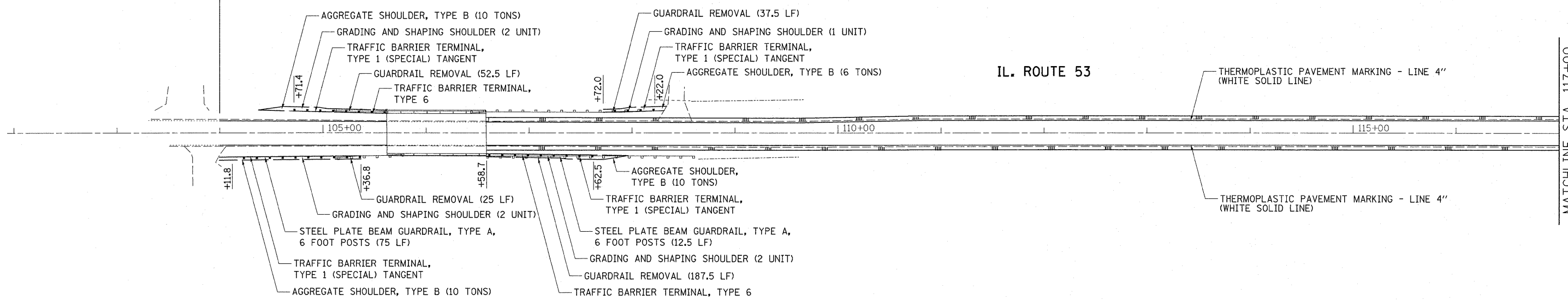

MATCHLINE STA. 117+00

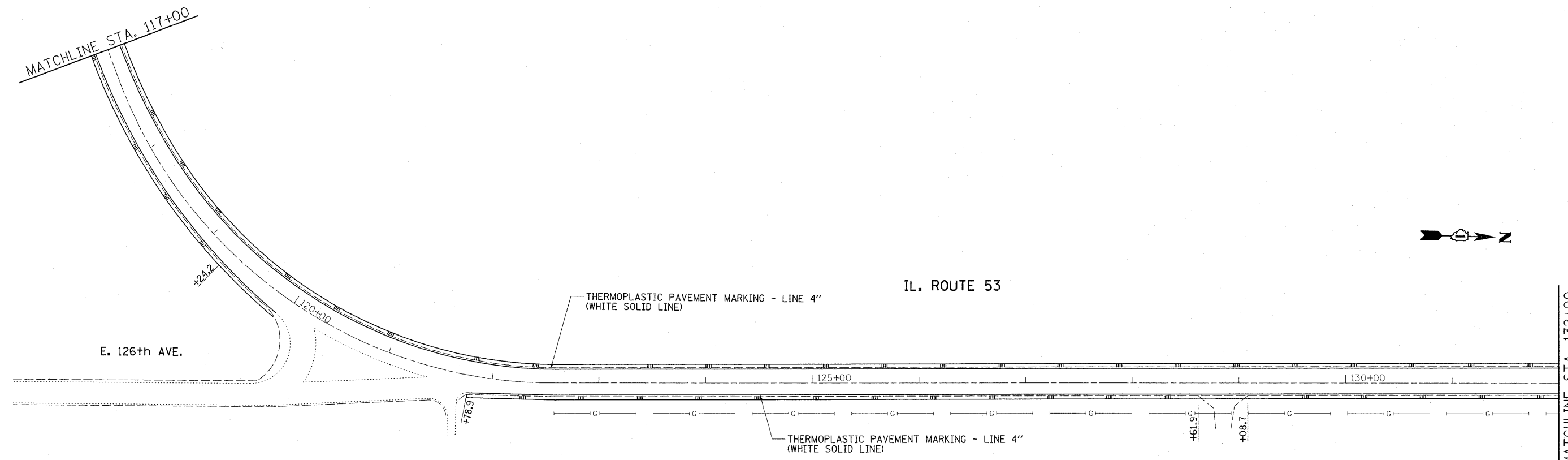

LEGEND

||| PROPOSED SHOULDER RUMBLE STRIPS

FILE NAME =	USER NAME = qureshiya	DESIGNED -	REVISED -
c:\pw\work\pwi\dot\qureshiya\c0212337\012609-sht-plen.dgn		DRAWN -	REVISED -
PLOT SCALE = 50.0000' / IN.		CHECKED -	REVISED -
PLOT DATE = 10/28/2010		DATE -	REVISED -

**STATE OF ILLINOIS
DEPARTMENT OF TRANSPORTATION**

**ROADWAY PLAN
IL. ROUTE 53 (FORKED CREEK - US 52)**

SCALE: 1"=50' SHEET NO. OF SHEETS STA. TO STA.

F.A.P. RTE. 846/357	SECTION 2010-133-1	COUNTY WILL	TOTAL SHEETS 54	SHEET NO. 9
CONTRACT NO. 60F75				ILLINOIS FED. AID PROJECT

MATCHLINE STA. 162+00

MATCHLINE STA. 177+00

IL. ROUTE 53

THERMOPLASTIC PAVEMENT MARKING - LINE 4" (WHITE SOLID LINE)

THERMOPLASTIC PAVEMENT MARKING - LINE 4" (WHITE SOLID LINE)

NEW RIVER RD.



MATCHLINE STA. 177+00

MATCHLINE STA. 192+00

IL. ROUTE 53

THERMOPLASTIC PAVEMENT MARKING - LINE 4" (WHITE SOLID LINE)

THERMOPLASTIC PAVEMENT MARKING - LINE 4" (WHITE SOLID LINE)



LEGEND

||| ||| PROPOSED SHOULDER RUMBLE STRIPS

FILE NAME =	USER NAME = qureshiya	DESIGNED -	REVISED -
c:\pw_work\pwidot\qureshiya\d0212337\012609-shtrplan.dgn		DRAWN -	REVISED -
PLOT SCALE = 50.0000' / IN.		CHECKED -	REVISED -
PLOT DATE = 10/28/2010		DATE -	REVISED -

**STATE OF ILLINOIS
DEPARTMENT OF TRANSPORTATION**

**ROADWAY PLAN
IL. ROUTE 53 (FORKED CREEK - US 52)**

SCALE: 1"=50' SHEET NO. OF SHEETS STA. TO STA.

F.A.P. RTE. 846/357	SECTION 2010-133-1	COUNTY WILL	TOTAL SHEETS 54	SHEET NO. 11
CONTRACT NO. 60F75			ILLINOIS FED. AID PROJECT	

IL. ROUTE 53

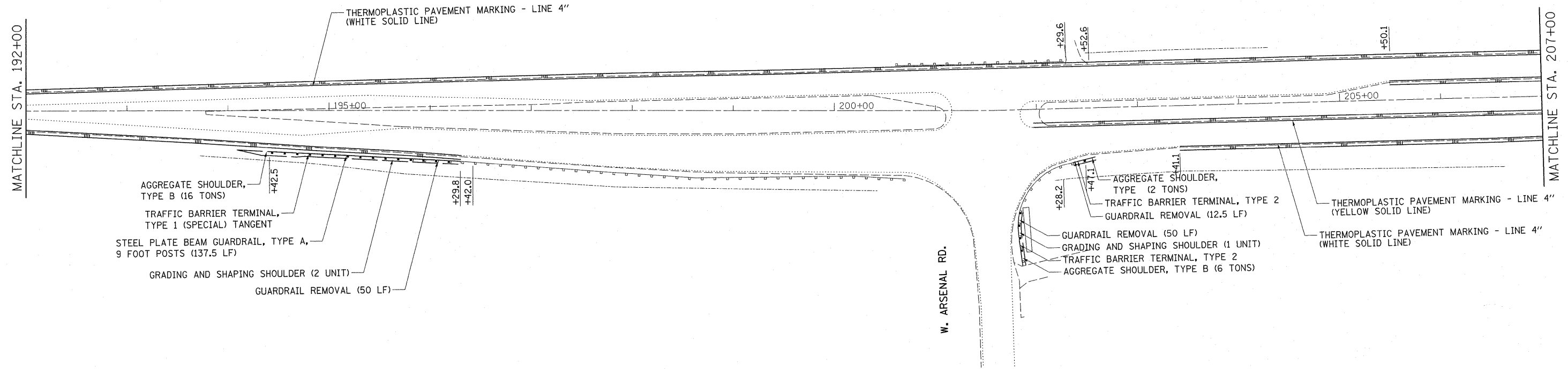
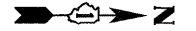

IL. ROUTE 53

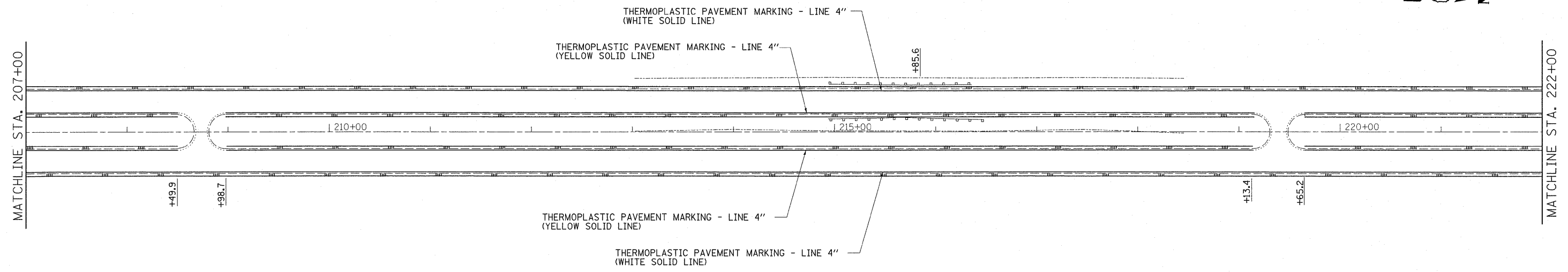

LEGEND

||| PROPOSED SHOULDER RUMBLE STRIPS

FILE NAME =	USER NAME = qureshiya	DESIGNED -	REVISED -
c:\pw_work\pisd\qureshiya\0212337\012609-sht-plan.dgn		DRAWN -	REVISED -
PLOT SCALE = 50.0000' / IN.		CHECKED -	REVISED -
PLOT DATE = 10/28/2010		DATE -	REVISED -

STATE OF ILLINOIS
DEPARTMENT OF TRANSPORTATION

ROADWAY PLAN			
IL. ROUTE 53 (FORKED CREEK - US 52)			
SCALE: 1"=50'	SHEET NO.	OF SHEETS	STA. TO STA.

F.A.P. RTE.	SECTION	COUNTY	TOTAL SHEETS	SHEET NO.
846/357	2010-133-1	WILL	54	12
CONTRACT NO. 60F75				
ILLINOIS FED. AID PROJECT				

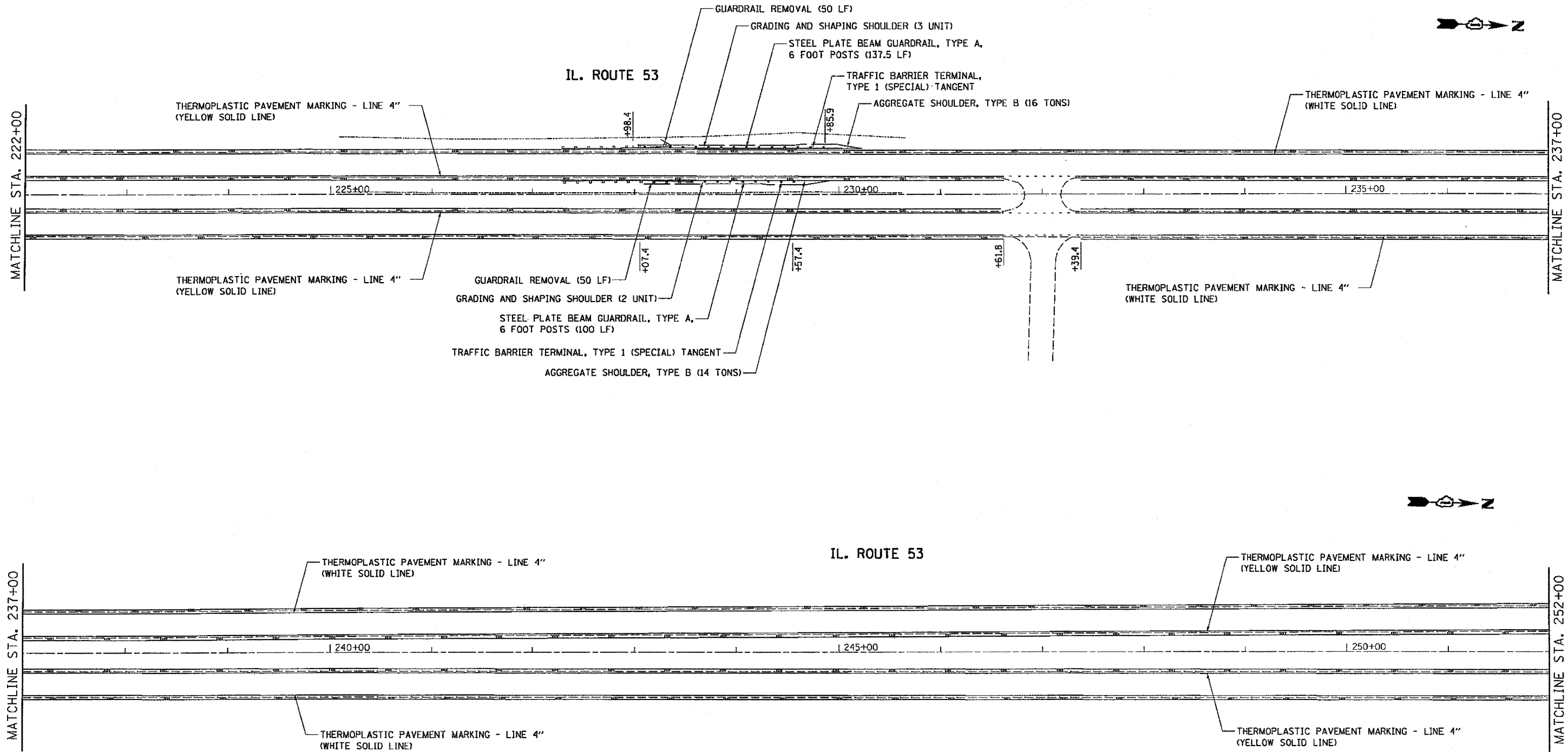

NOTE:
 OMIT ANY WORK FROM STATION 249+00 TO STATION 260+00
 AND FROM STATION 486+00 TO STATION 496+00.

LEGEND
 ■■■ PROPOSED SHOULDER RUMBLE STRIPS

FILE NAME =	USER NAME = qureshiya	DESIGNED -	REVISED -	STATE OF ILLINOIS DEPARTMENT OF TRANSPORTATION	ROADWAY PLAN			F.A.P. RTE.	SECTION	COUNTY	TOTAL SHEETS	SHEET NO.
ct:\pr_work\pwr\dot\qureshiya\08212337\012697-shr-plan.dgn		DRAWN -	REVISED -		IL ROUTE 53 (FORKED CREEK - US 52)			846/357	2010-133-1	WILL	54	13
		CHECKED -	REVISED -		SCALE: 1"=50'	SHEET NO.	OF SHEETS	STA.	TO STA.	CONTRACT NO. 60F75		
		DATE -	REVISED -		ILLINOIS FED. AID PROJECT							

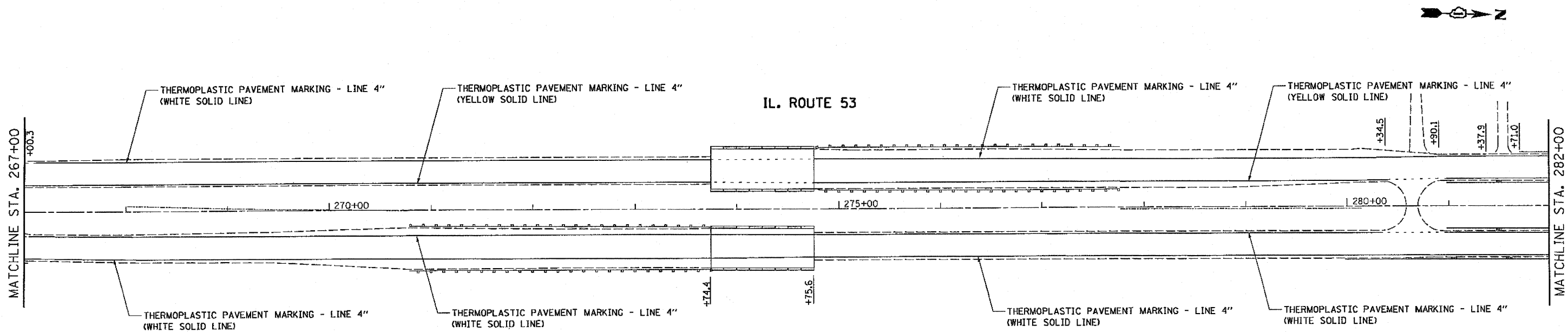
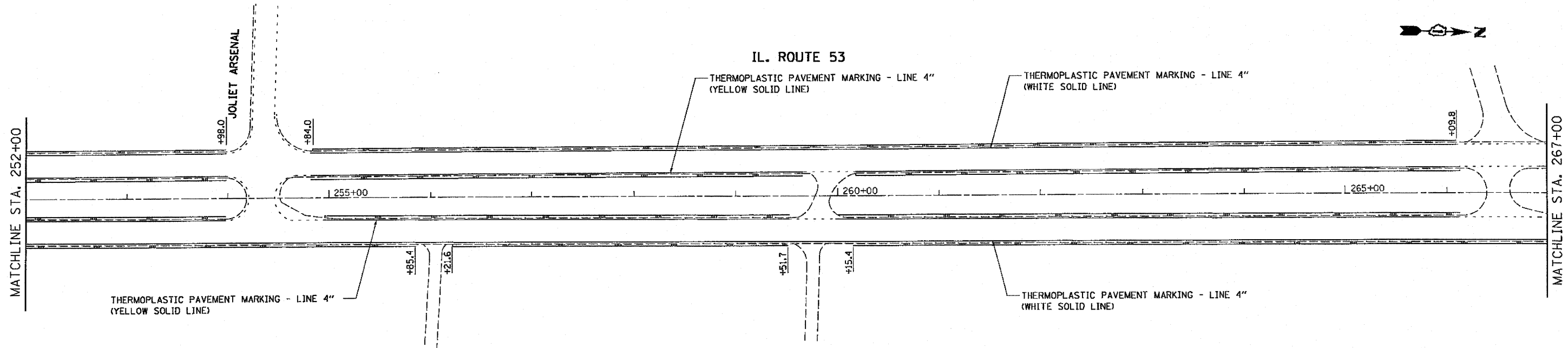

NOTE:

OMIT ANY WORK FROM STATION 249+00 TO STATION 260+00
AND FROM STATION 486+00 TO STATION 496+00.

BETWEEN STA 267+00 TO STA 282+00 AND STA 600+00 TO STA 615+00 ROADWORK WILL BE LIMITED TO PROPOSED "SHOULDER RUMBLE STRIP". THE OUTSIDE AND INSIDE LANE LINES SHALL ALSO BE RE-STRIPED WITH "THERMOPLASTIC PAVEMENT MARKING - LINE, 4 INCHES"

LEGEND

▨▨▨▨▨ PROPOSED SHOULDER RUMBLE STRIPS

FILE NAME = c:\pwwork\pwwork\qreashya\10212337\1012809-shl-plan.dgn	USER NAME = qreashya	DESIGNED -	REVISED -	STATE OF ILLINOIS DEPARTMENT OF TRANSPORTATION	ROADWAY PLAN		F.A.P. RTE.	SECTION	COUNTY	TOTAL SHEETS	SHEET NO.
	PLOT SCALE = 100.0000' / IN.	DRAWN -	REVISED -		IL. ROUTE 53 (FORKED CREEK - US 52)	846/357	2010-133-1	WILL	54	14	
PLOT DATE = 10/28/2010	DATE -	REVISED -	REVISED -	SCALE: 1"=50'	SHEET NO.	OF SHEETS	STA.	TO STA.	CONTRACT NO. 60F75 ILLINOIS FED. AID PROJECT		

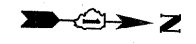

IL. ROUTE 53

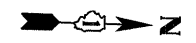
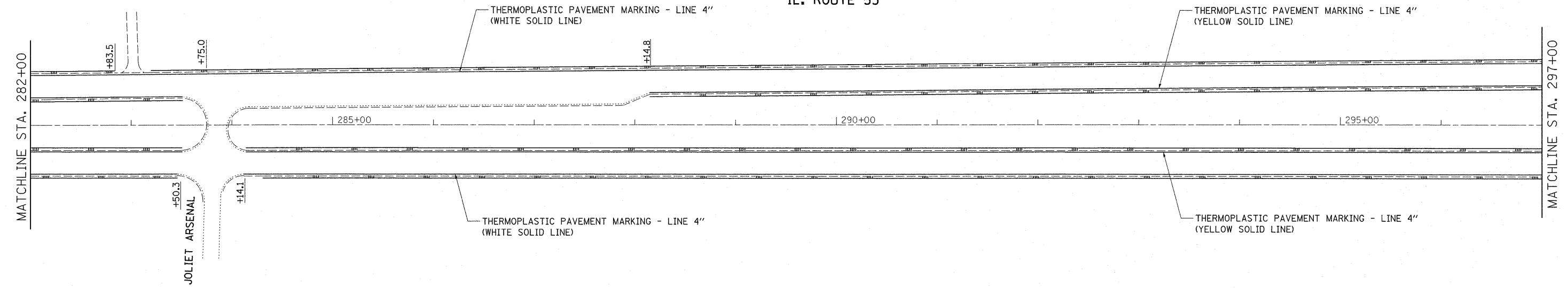

IL. ROUTE 53

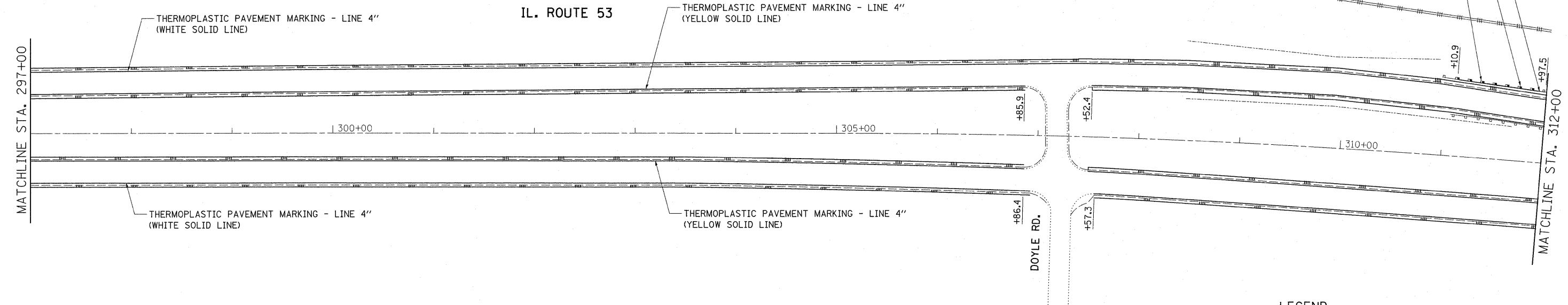

LEGEND

||| PROPOSED SHOULDER RUMBLE STRIPS

FILE NAME = c:\pwork\pwork\qureshiya\0212337\0128609-sht-plan.dgn	USER NAME = qureshiya	DESIGNED -	REVISED -	STATE OF ILLINOIS DEPARTMENT OF TRANSPORTATION	ROADWAY PLAN IL. ROUTE 53 (FORKED CREEK - US 52)			F.A.P. RTE. 846/357	SECTION 2010-133-I	COUNTY WILL	TOTAL SHEETS 54	SHEET NO. 15
	PLOT SCALE = 50.0000' / IN.	CHECKED -	REVISED -		SCALE: 1"=50'	SHEET NO.	OF SHEETS	STA.	TO STA.	CONTRACT NO. 60F75		
PLOT DATE = 10/28/2010	DATE -	REVISED -	REVISED -		ILLINOIS FED. AID PROJECT							

IL. ROUTE 53

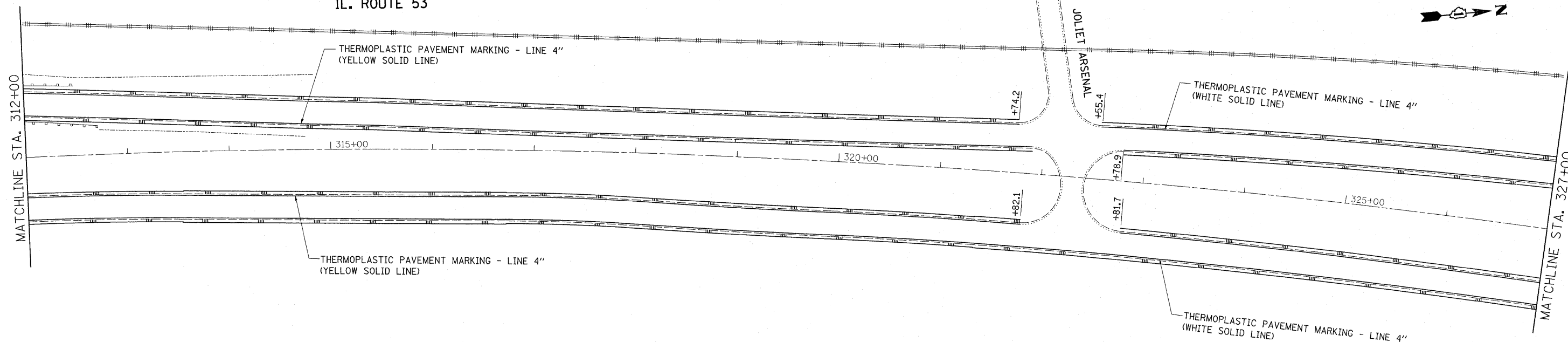

IL. ROUTE 53

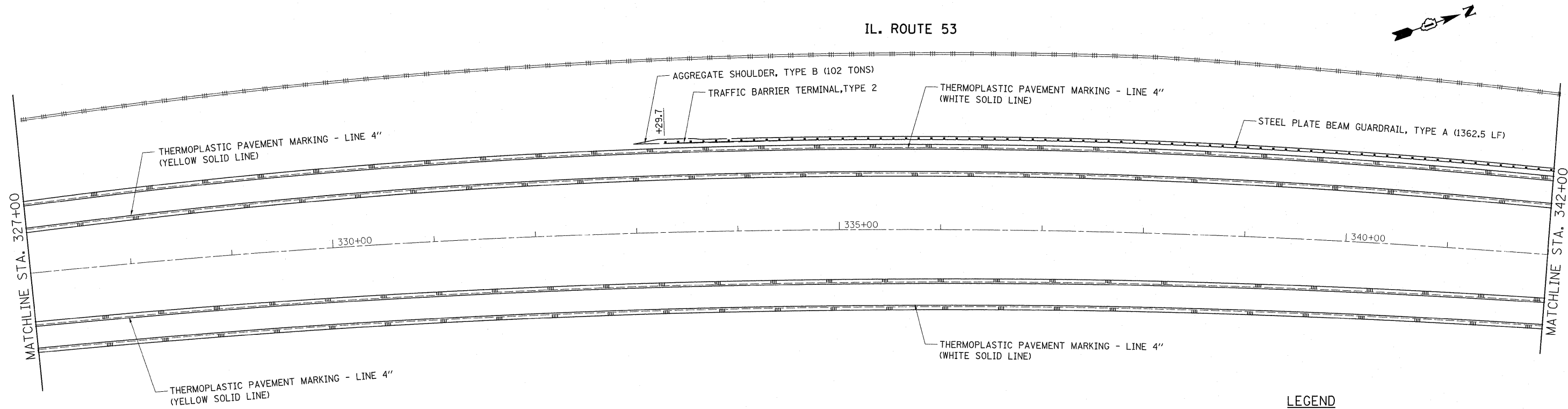

LEGEND

||| PROPOSED SHOULDER RUMBLE STRIPS

FILE NAME =	USER NAME = qureshiya	DESIGNED -	REVISED -
c:\pw_work\pwidot\qureshiya\0212337\0122609-sht-plen.dgn		DRAWN -	REVISED -
PLOT SCALE = 50.0000' / IN.		CHECKED -	REVISED -
PLOT DATE = 10/26/2010		DATE -	REVISED -

STATE OF ILLINOIS
DEPARTMENT OF TRANSPORTATION

ROADWAY PLAN
IL. ROUTE 53 (FORKED CREEK - US 52)

SCALE: 1"=50' SHEET NO. OF SHEETS STA. TO STA.

F.A.P. RTE. 846/357	SECTION 2010-133-1	COUNTY WILL	TOTAL SHEETS 54	SHEET NO. 16
				CONTRACT NO. 60F75
ILLINOIS FED. AID PROJECT				

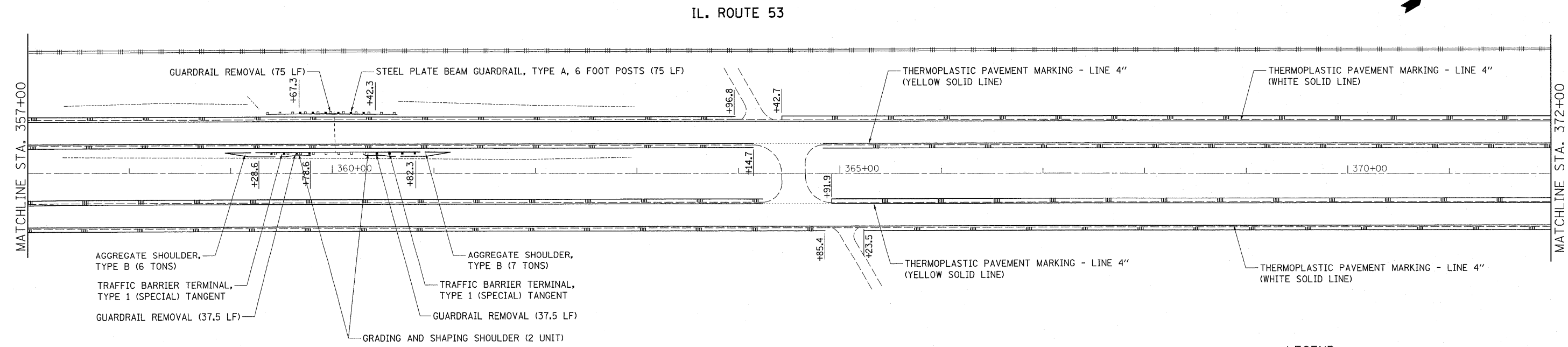
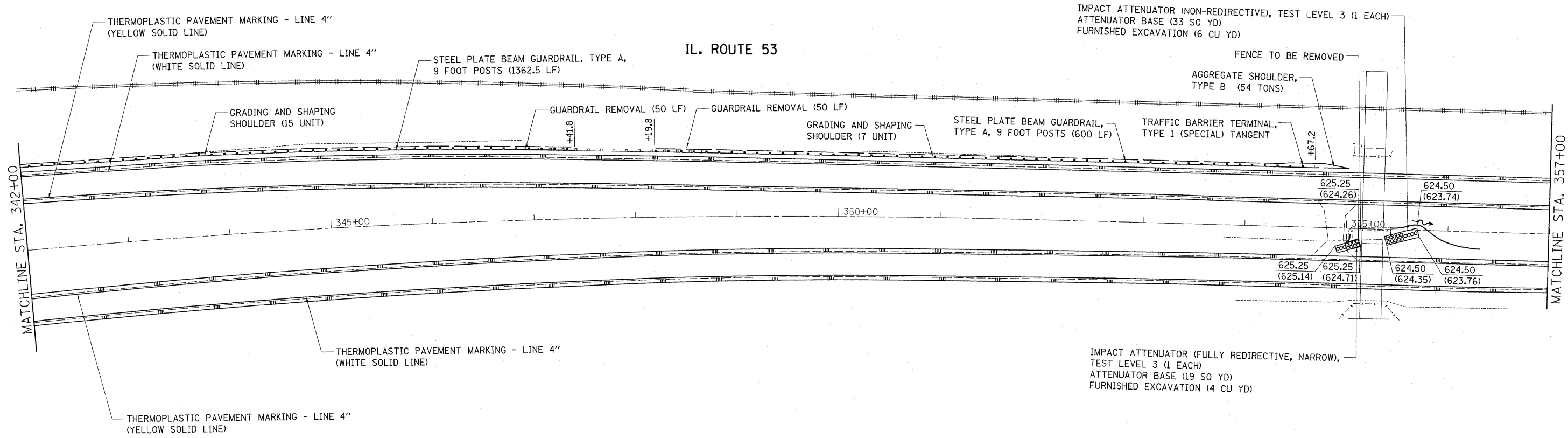
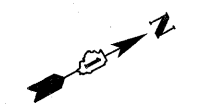

LEGEND
 |||| PROPOSED SHOULDER RUMBLE STRIPS

FILE NAME =	USER NAME = qureshiya	DESIGNED -	REVISED -
c:\pw\work\pwsdot\qureshiya\0212337\0123609-sht-plan.dgn		DRAWN -	REVISED -
PLOT SCALE = 50.0000' / IN.		CHECKED -	REVISED -
PLOT DATE = 10/28/2010		DATE -	REVISED -

**STATE OF ILLINOIS
 DEPARTMENT OF TRANSPORTATION**

**ROADWAY PLAN
 IL. ROUTE 53 (FORKED CREEK - US 52)**

SCALE: 1"=50' SHEET NO. OF SHEETS STA. TO STA.

F.A.P. RTE.	SECTION	COUNTY	TOTAL SHEETS	SHEET NO.
846/357	2010-133-1	WILL	54	17
CONTRACT NO. 60F75				
ILLINOIS FED. AID PROJECT				

IL. ROUTE 53

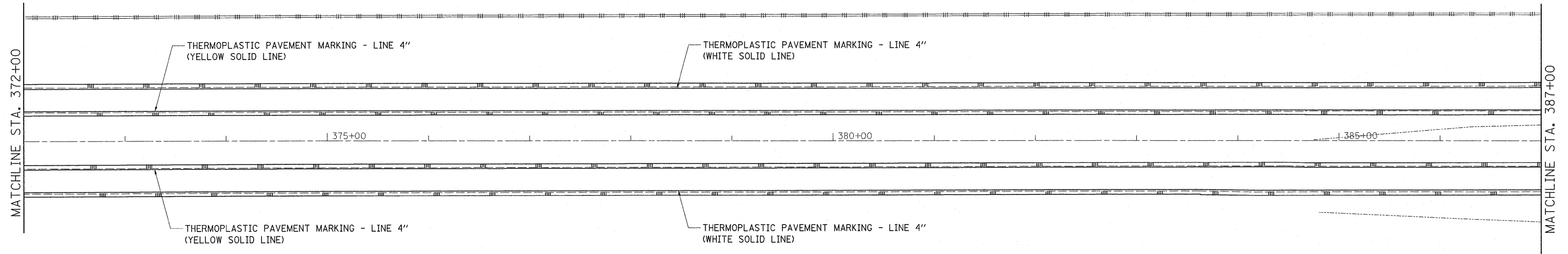
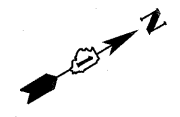

IL. ROUTE 53

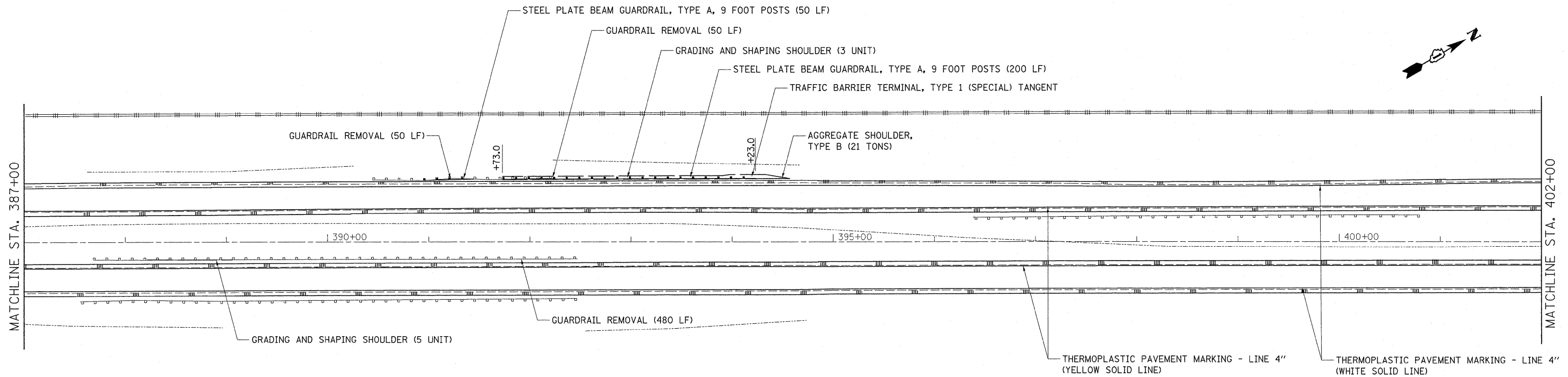
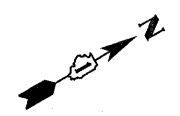

LEGEND

||| PROPOSED SHOULDER RUMBLE STRIPS

FILE NAME =	USER NAME = qureshiya	DESIGNED -	REVISED -
c:\pwork\pwork\qureshiya\0212337\0122609-sht-plan.dgn		DRAWN -	REVISED -
PLOT SCALE = 50.0000' / IN.		CHECKED -	REVISED -
PLOT DATE = 10/28/2010		DATE -	REVISED -

STATE OF ILLINOIS
DEPARTMENT OF TRANSPORTATION

ROADWAY PLAN			
IL. ROUTE 53 (FORKED CREEK - US 52)			
SCALE: 1"=50'	SHEET NO.	OF SHEETS	STA. TO STA.

F.A.P. RTE. 846/357	SECTION 2010-133-I	COUNTY WILL	TOTAL SHEETS 54	SHEET NO. 18
				CONTRACT NO. 60F75
ILLINOIS FED. AID PROJECT				

IL. ROUTE 53

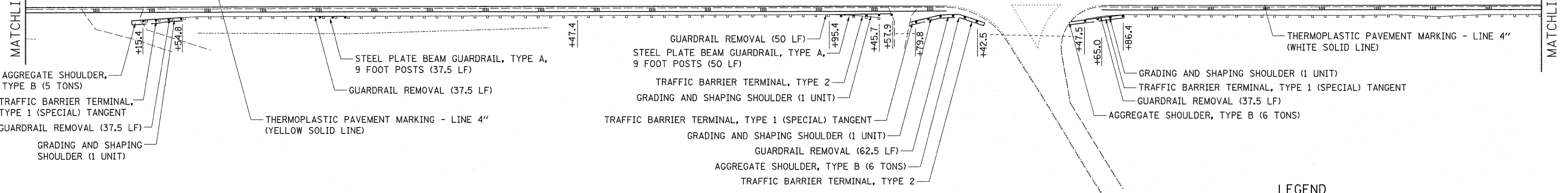
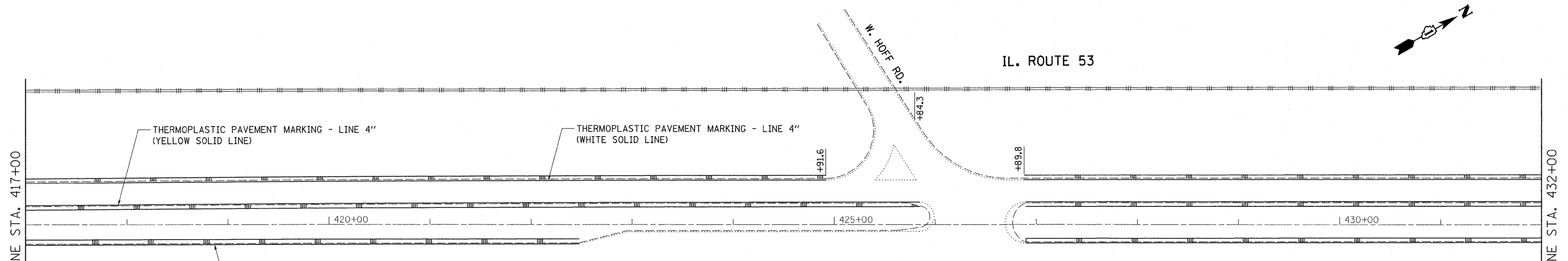
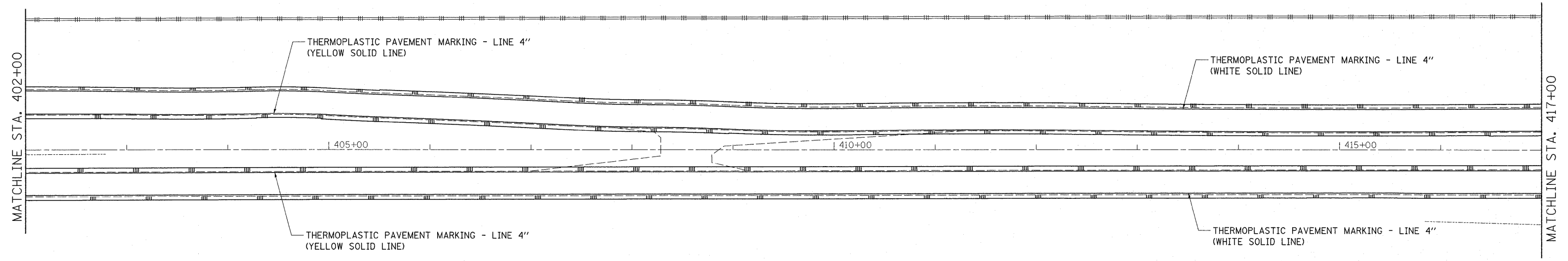
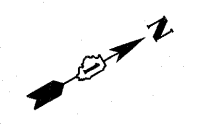

LEGEND

||| PROPOSED SHOULDER RUMBLE STRIPS

FILE NAME =	USER NAME = qureshiya	DESIGNED -	REVISED -
c:\pwork\pwork\qureshiya\d0212337\012609-shtr-plan.dgn		DRAWN -	REVISED -
PLOT SCALE = 50.0000' / IN.		CHECKED -	REVISED -
PLOT DATE = 10/28/2010		DATE -	REVISED -

**STATE OF ILLINOIS
DEPARTMENT OF TRANSPORTATION**

**ROADWAY PLAN
IL. ROUTE 53 (FORKED CREEK - US 52)**

SCALE: 1"=50' SHEET NO. OF SHEETS STA. TO STA.

F.A.P. RTE. 846/357	SECTION 2010-133-1	COUNTY WILL	TOTAL SHEETS 54	SHEET NO. 19
				CONTRACT NO. 60F75
ILLINOIS FED. AID PROJECT				

IL. ROUTE 53

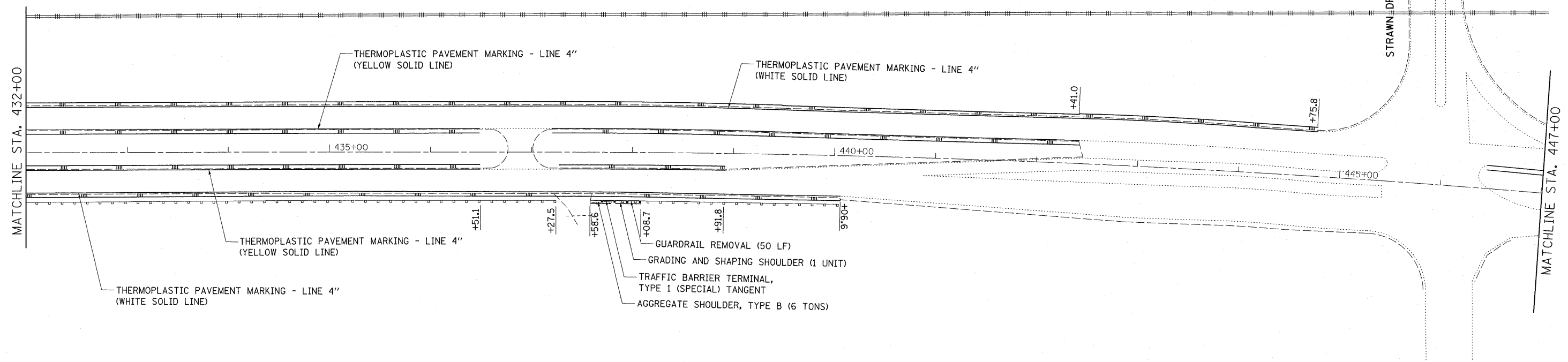
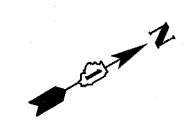

- THERMOPLASTIC PAVEMENT MARKING - LINE 4" (YELLOW SOLID LINE)
- THERMOPLASTIC PAVEMENT MARKING - LINE 4" (WHITE SOLID LINE)
- THERMOPLASTIC PAVEMENT MARKING - LINE 4" (YELLOW SOLID LINE)
- THERMOPLASTIC PAVEMENT MARKING - LINE 4" (WHITE SOLID LINE)
- GUARDRAIL REMOVAL (50 LF)
- GRADING AND SHAPING SHOULDER (1 UNIT)
- TRAFFIC BARRIER TERMINAL, TYPE 1 (SPECIAL) TANGENT
- AGGREGATE SHOULDER, TYPE B (6 TONS)

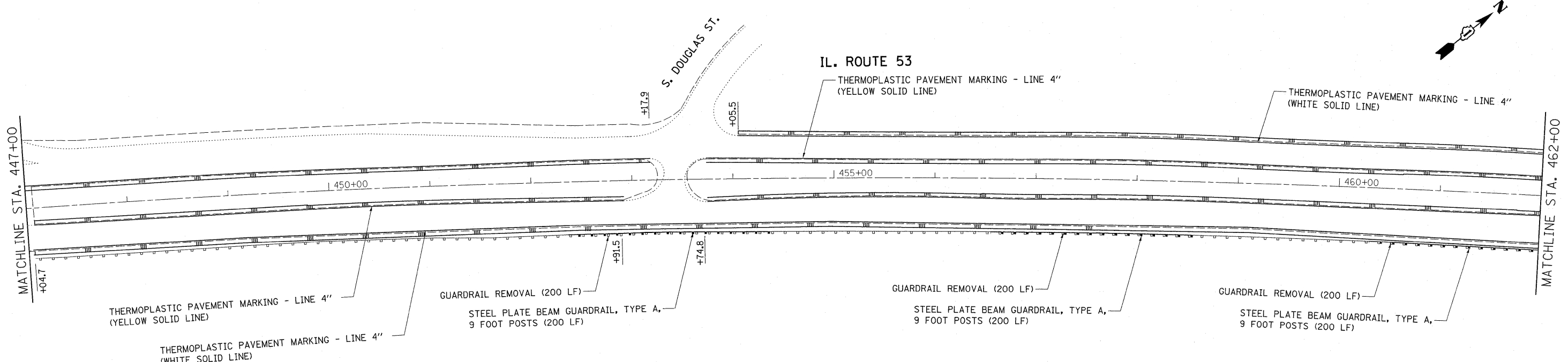
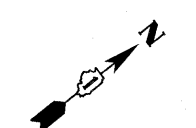

- THERMOPLASTIC PAVEMENT MARKING - LINE 4" (YELLOW SOLID LINE)
- THERMOPLASTIC PAVEMENT MARKING - LINE 4" (WHITE SOLID LINE)
- THERMOPLASTIC PAVEMENT MARKING - LINE 4" (YELLOW SOLID LINE)
- THERMOPLASTIC PAVEMENT MARKING - LINE 4" (WHITE SOLID LINE)
- GUARDRAIL REMOVAL (200 LF)
- STEEL PLATE BEAM GUARDRAIL, TYPE A, 9 FOOT POSTS (200 LF)
- GUARDRAIL REMOVAL (200 LF)
- STEEL PLATE BEAM GUARDRAIL, TYPE A, 9 FOOT POSTS (200 LF)
- GUARDRAIL REMOVAL (200 LF)
- STEEL PLATE BEAM GUARDRAIL, TYPE A, 9 FOOT POSTS (200 LF)

LEGEND
 |||| PROPOSED SHOULDER RUMBLE STRIPS

FILE NAME =	USER NAME = qureshiya	DESIGNED -	REVISED -	STATE OF ILLINOIS DEPARTMENT OF TRANSPORTATION	ROADWAY PLAN			F.A.P. RTE.	SECTION	COUNTY	TOTAL SHEETS	SHEET NO.
c:\pw\work\pwsdot\qureshiya\d0212337\012609-sht-plen.dgn		DRAWN -	REVISED -		IL. ROUTE 53 (FORKED CREEK - US 52)			846/357	2010-133-1	WILL	54	20
		CHECKED -	REVISED -		SCALE: 1"=50'			SHEET NO. OF SHEETS STA. TO STA.			CONTRACT NO. 60F75	
		DATE = 10/29/2010	REVISED -		ILLINOIS FED. AID PROJECT							

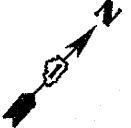
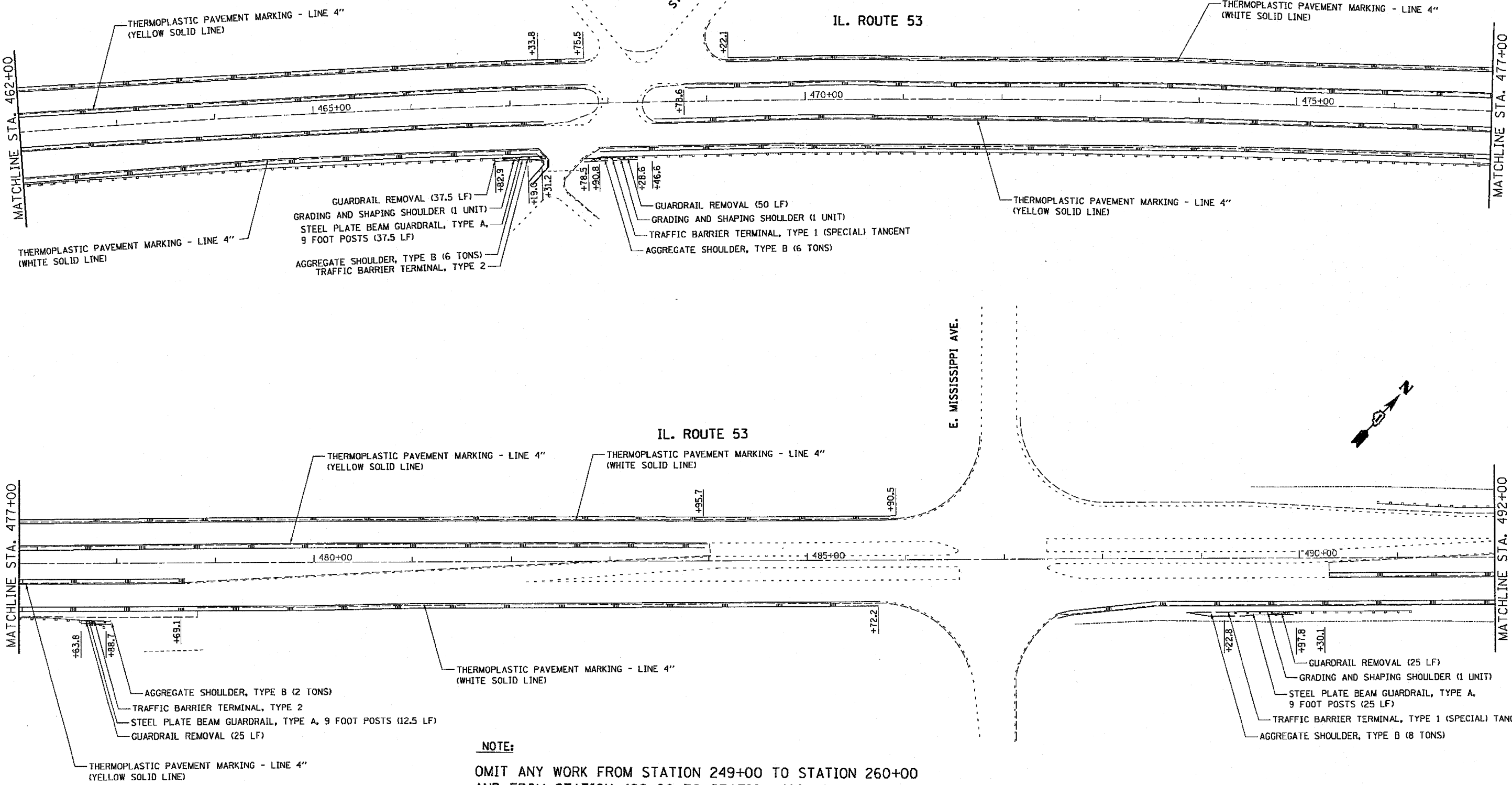
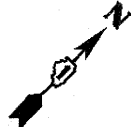

NOTE:
 OMIT ANY WORK FROM STATION 249+00 TO STATION 260+00
 AND FROM STATION 486+00 TO STATION 496+00.

LEGEND
 ■ ■ ■ PROPOSED SHOULDER RUMBLE STRIPS

FILE NAME = ca:\pki\work\pki\dat\qureshiya\d8212337\012	USER NAME = qureshiya	DESIGNED -	REVISED -	STATE OF ILLINOIS DEPARTMENT OF TRANSPORTATION	ROADWAY PLAN			F.A.P. RTE. 846/397	SECTION 2010-133-1	COUNTY WILL	TOTAL SHEETS 54	SHEET NO. 21
	609-shr-plan.dgn	DRAWN -	REVISED -		IL ROUTE 53 (FORKED CREEK - US 52)			CONTRACT NO. 60F75		ILLINOIS FED. AID PROJECT		
PLOT SCALE = 100.0000 "/ IN.	CHECKED -	REVISED -	SCALE: 1"=50'		SHEET NO. OF SHEETS	STA. TO STA.						
PLOT DATE = 10/28/2010	DATE -	REVISED -										

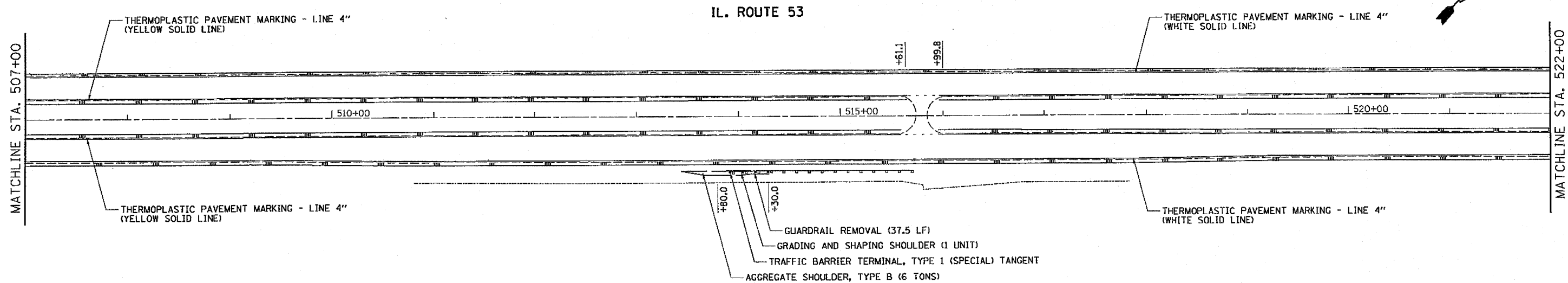
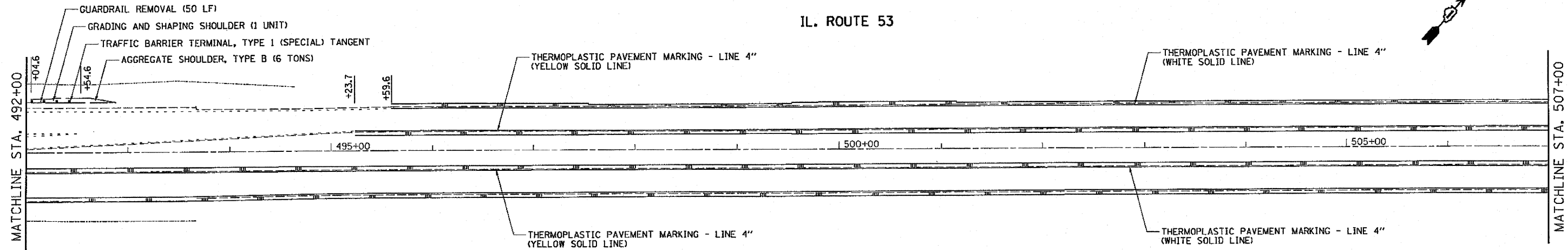

NOTE:

OMIT ANY WORK FROM STATION 249+00 TO STATION 260+00
AND FROM STATION 486+00 TO STATION 496+00.

LEGEND

▨▨▨▨▨ PROPOSED SHOULDER RUMBLE STRIPS

FILE NAME =	USER NAME = qureshiya	DESIGNED -	REVISED -
at:\pwwork\pwwork\qureshiya\08212337\012	609-shr-plan.dgn	DRAWN -	REVISED -
PLOT SCALE = 100.0000' / IN.		CHECKED -	REVISED -
PLOT DATE = 10/28/2010		DATE -	REVISED -

**STATE OF ILLINOIS
DEPARTMENT OF TRANSPORTATION**

ROADWAY PLAN			
IL ROUTE 53 (FORKED CREEK - US 52)			
SCALE: 1"=50'	SHEET NO.	OF SHEETS	STA. TO STA.

F.A.P. RTE.	SECTION	COUNTY	TOTAL SHEETS	SHEET NO.
846/357	2010-133-1	WILL	54	22
CONTRACT NO. 60F75				
ILLINOIS FED. AID PROJECT				

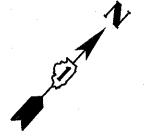
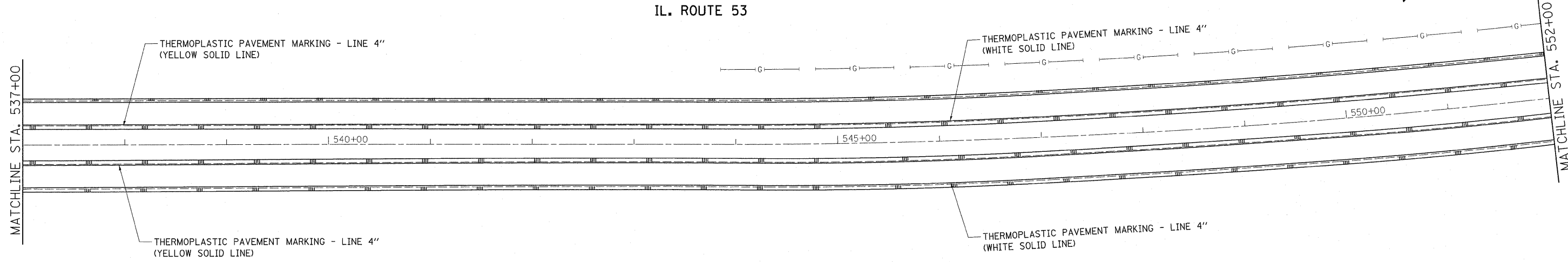
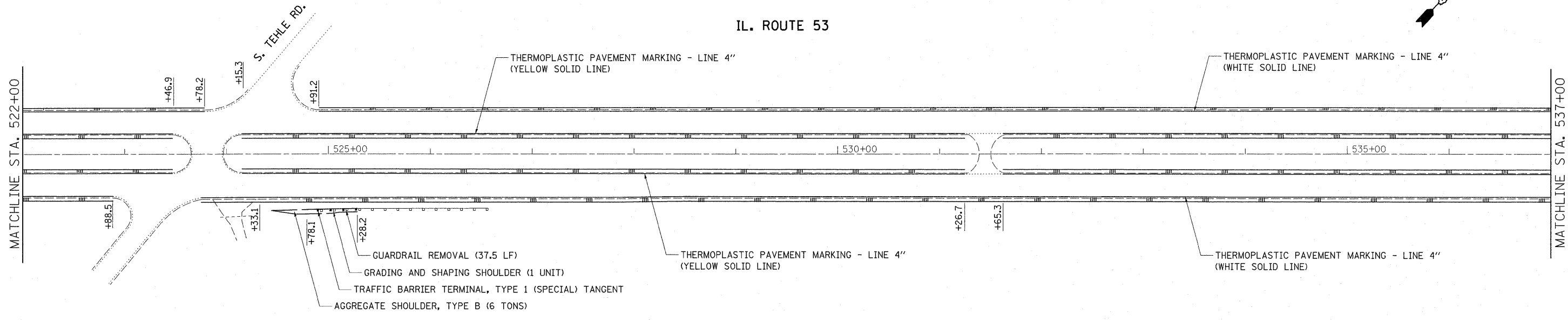
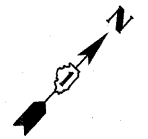

LEGEND

||| ||| PROPOSED SHOULDER RUMBLE STRIPS

FILE NAME =	USER NAME = qureshiya	DESIGNED -	REVISED -
c:\pw_work\pwadot\qureshiya\0212337\0123609\shp\plan.dgn		DRAWN -	REVISED -
PLOT SCALE = 50.0000' / IN.		CHECKED -	REVISED -
PLOT DATE = 10/28/2010		DATE -	REVISED -

**STATE OF ILLINOIS
DEPARTMENT OF TRANSPORTATION**

**ROADWAY PLAN
IL. ROUTE 53 (FORKED CREEK - US 52)**

SCALE: 1"=50' SHEET NO. OF SHEETS STA. TO STA.

F.A.P. RTE. 846/357	SECTION 2010-133-1	COUNTY WILL	TOTAL SHEETS 54	SHEET NO. 23
CONTRACT NO. 60F75				ILLINOIS FED. AID PROJECT

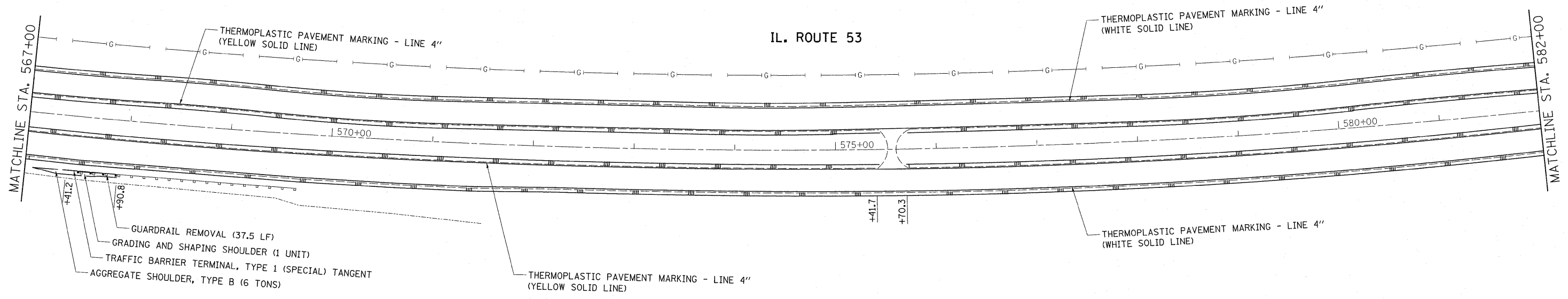
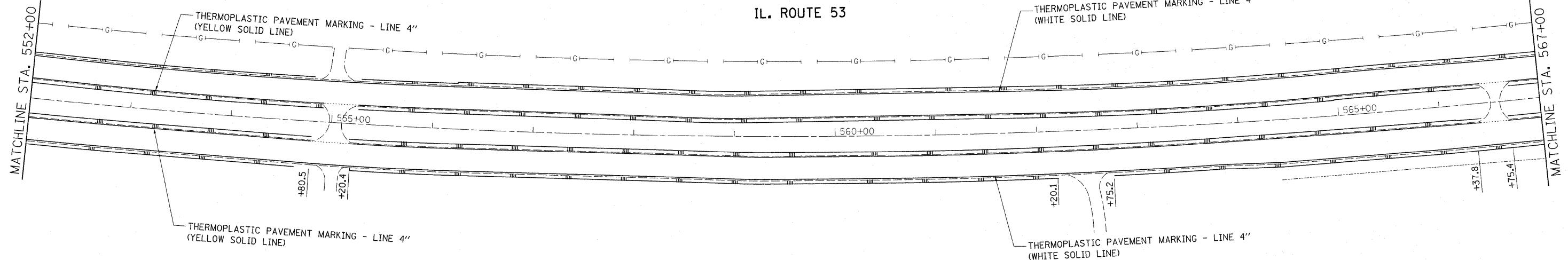

GUARDRAIL REMOVAL (37.5 LF)
 GRADING AND SHAPING SHOULDER (1 UNIT)
 TRAFFIC BARRIER TERMINAL, TYPE 1 (SPECIAL) TANGENT
 AGGREGATE SHOULDER, TYPE B (6 TONS)

LEGEND

PROPOSED SHOULDER RUMBLE STRIPS

FILE NAME =	USER NAME = qureshiya	DESIGNED -	REVISED -
c:\pwork\pwork\qureshiya\d0212337\122609-sht-plen.dgn		DRAWN -	REVISED -
PLOT SCALE = 50.0000' / IN.		CHECKED -	REVISED -
PLOT DATE = 10/28/2010		DATE -	REVISED -

STATE OF ILLINOIS
DEPARTMENT OF TRANSPORTATION

ROADWAY PLAN
IL. ROUTE 53 (FORKED CREEK - US 52)

SCALE: 1"=50' SHEET NO. OF SHEETS STA. TO STA.

F.A.P. RTE.	SECTION	COUNTY	TOTAL SHEETS	SHEET NO.
846/357	2010-133-I	WILL	54	24
CONTRACT NO. 60F75			ILLINOIS FED. AID PROJECT	

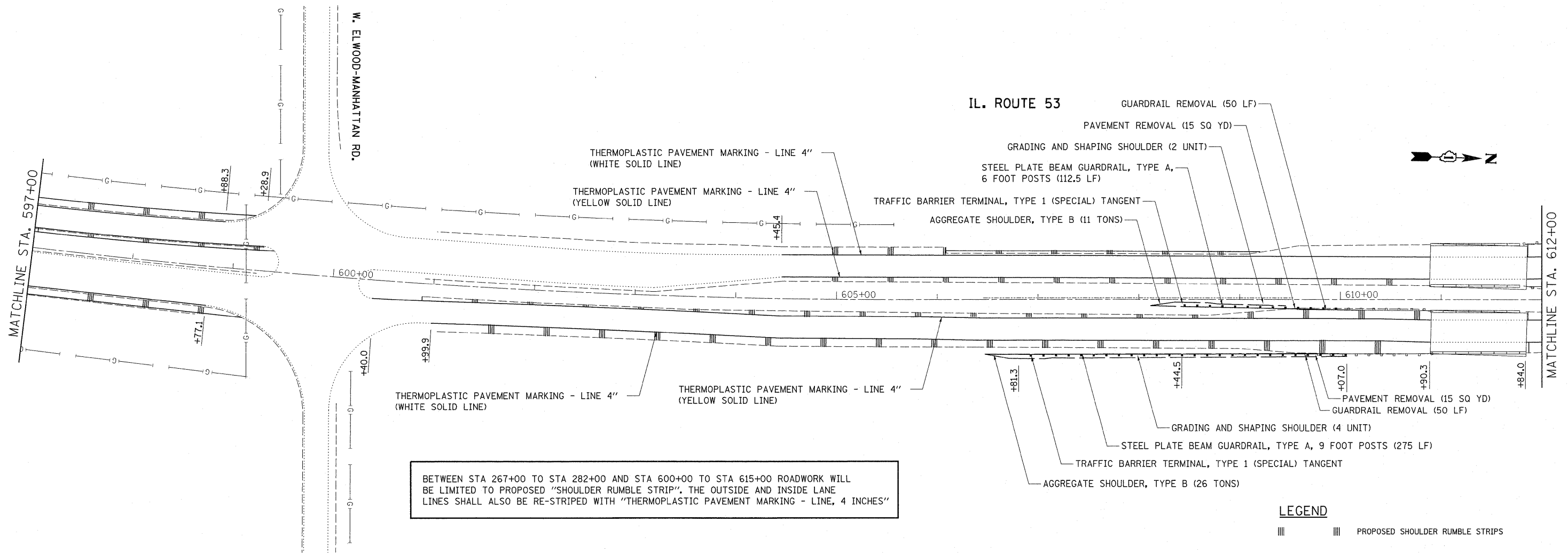
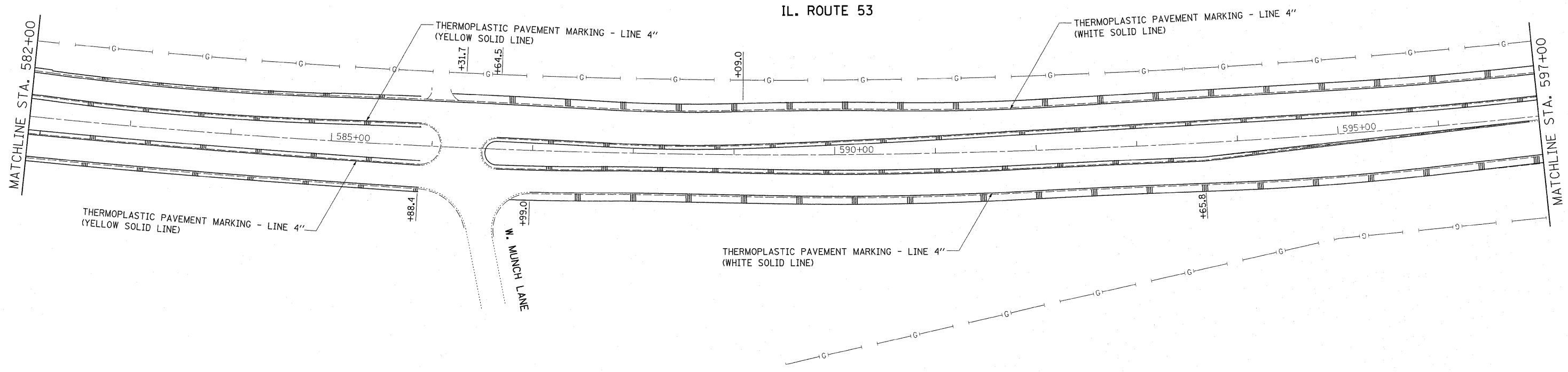

BETWEEN STA 267+00 TO STA 282+00 AND STA 600+00 TO STA 615+00 ROADWORK WILL BE LIMITED TO PROPOSED "SHOULDER RUMBLE STRIP", THE OUTSIDE AND INSIDE LANE LINES SHALL ALSO BE RE-STRIPED WITH "THERMOPLASTIC PAVEMENT MARKING - LINE, 4 INCHES"

FILE NAME =	USER NAME = qureshiya	DESIGNED -	REVISED -
ct:\pw_work\pwidot\qureshiya\0212337\0122609-shrtp1an.dgn		DRAWN -	REVISED -
PLOT SCALE = 50.0000' / IN.		CHECKED -	REVISED -
PLOT DATE = 10/28/2010		DATE -	REVISED -

**STATE OF ILLINOIS
DEPARTMENT OF TRANSPORTATION**

**ROADWAY PLAN
IL. ROUTE 53 (FORKED CREEK - US 52)**

SCALE: 1"=50' SHEET NO. OF SHEETS STA. TO STA.

F.A.P. RTE. 846/357	SECTION 2010-133-1	COUNTY WILL	TOTAL SHEETS 54	SHEET NO. 25
CONTRACT NO. 60F75				
ILLINOIS FED. AID PROJECT				

IL. ROUTE 53

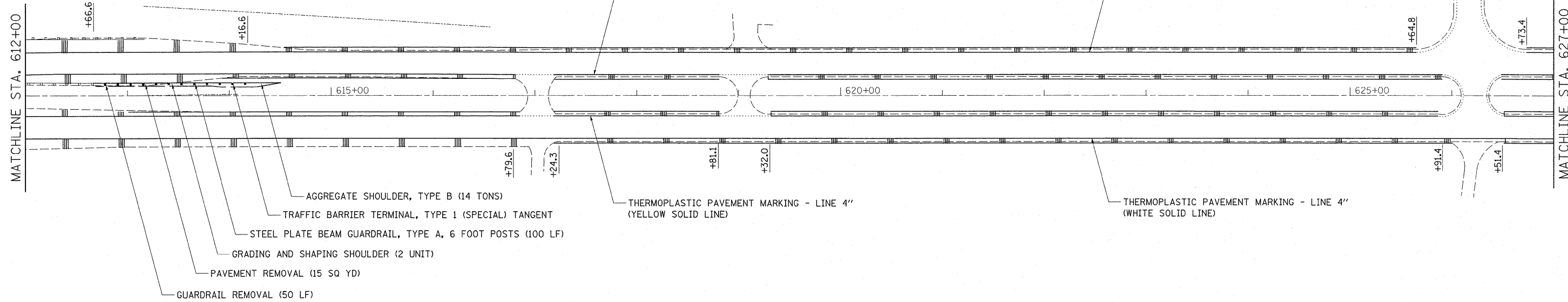

IL. ROUTE 53

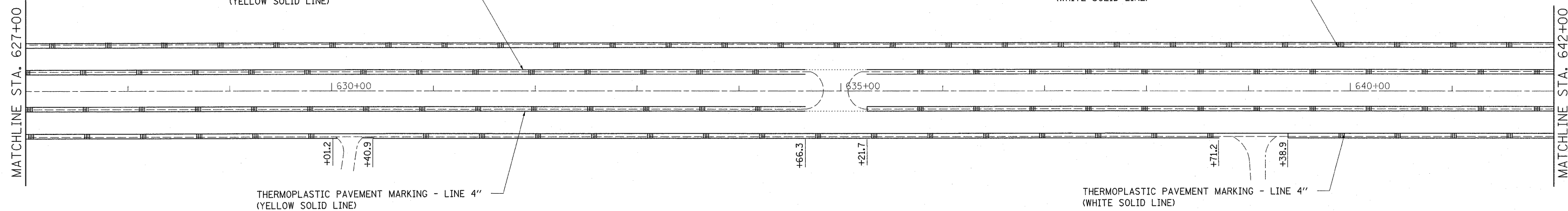

BETWEEN STA 267+00 TO STA 282+00 FOR SB LANES AND STA 270+00 TO STA 276+00 FOR NB LANES AND STA 586+00 TO 613+00 ROADWORK WILL BE LIMITED TO PROPOSED "SHOULDER RUMBLE STRIP" ON THE OUTSIDE LANES AND "PROPOSED RUMBLE STRIP, SPECIAL" ON THE INSIDE LANES. THE OUTSIDE AND INSIDE LANE LINES SHALL ALSO BE RE-STRIPED WITH "THERMOPLASTIC PAVEMENT MARKING - LINE, 4 INCHES"

LEGEND

||| PROPOSED SHOULDER RUMBLE STRIPS

FILE NAME =	USER NAME = qureshiya	DESIGNED -	REVISED -	STATE OF ILLINOIS DEPARTMENT OF TRANSPORTATION	ROADWAY PLAN			F.A.P. RTE. 846/357	SECTION 2010-133-1	COUNTY WILL	TOTAL SHEETS 54	SHEET NO. 26
c:\pw_work\pwidot\qureshiya\d0212337\012609-sht-plan.dgn		DRAWN -	REVISED -		IL. ROUTE 53 (FORKED CREEK - US 52)					CONTRACT NO. 60F75		
PLOT SCALE = 50.0000' / IN.		CHECKED -	REVISED -		SCALE: 1"=50'	SHEET NO.	OF SHEETS	STA.	TO STA.	ILLINOIS FED. AID PROJECT		
PLOT DATE = 10/28/2010		DATE -	REVISED -									

IL. ROUTE 53

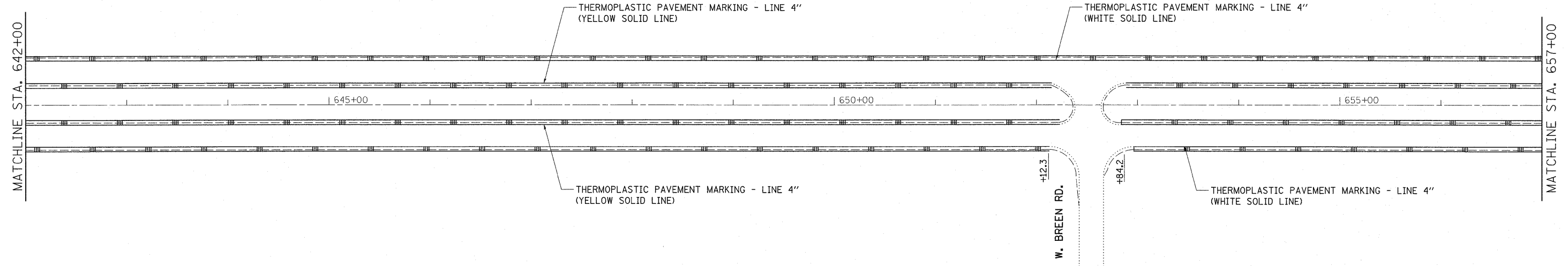

IL. ROUTE 53

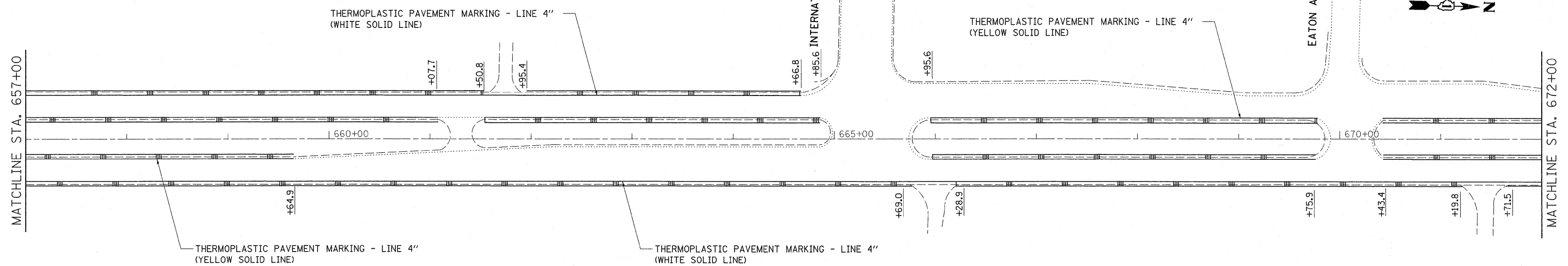
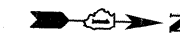

LEGEND

||| PROPOSED SHOULDER RUMBLE STRIPS

FILE NAME =	USER NAME = qureshiya	DESIGNED -	REVISED -
c:\pw_work\pwidot\qureshiya\d0212337\012609-sht-plan.dgn		DRAWN -	REVISED -
PLOT SCALE = 50.0000' / IN.		CHECKED -	REVISED -
PLOT DATE = 10/28/2010		DATE -	REVISED -

STATE OF ILLINOIS
DEPARTMENT OF TRANSPORTATION

ROADWAY PLAN			
IL. ROUTE 53 (FORKED CREEK - US 52)			
SCALE: 1"=50'	SHEET NO.	OF SHEETS	STA. TO STA.

F.A.P. RTE.	SECTION	COUNTY	TOTAL SHEETS	SHEET NO.
846/357	2010-133-1	WILL	54	27
CONTRACT NO. 60F75			ILLINOIS FED. AID PROJECT	

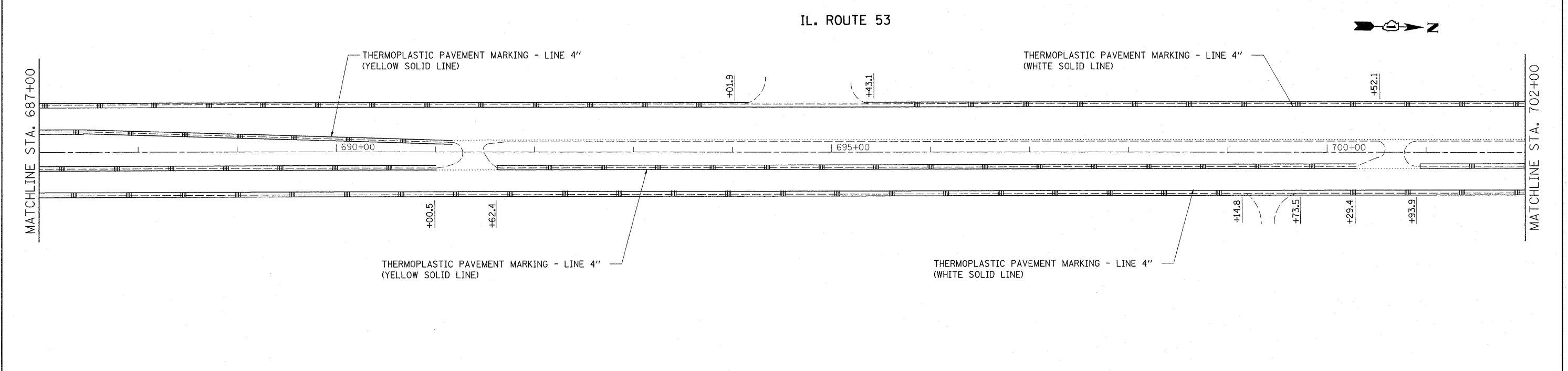
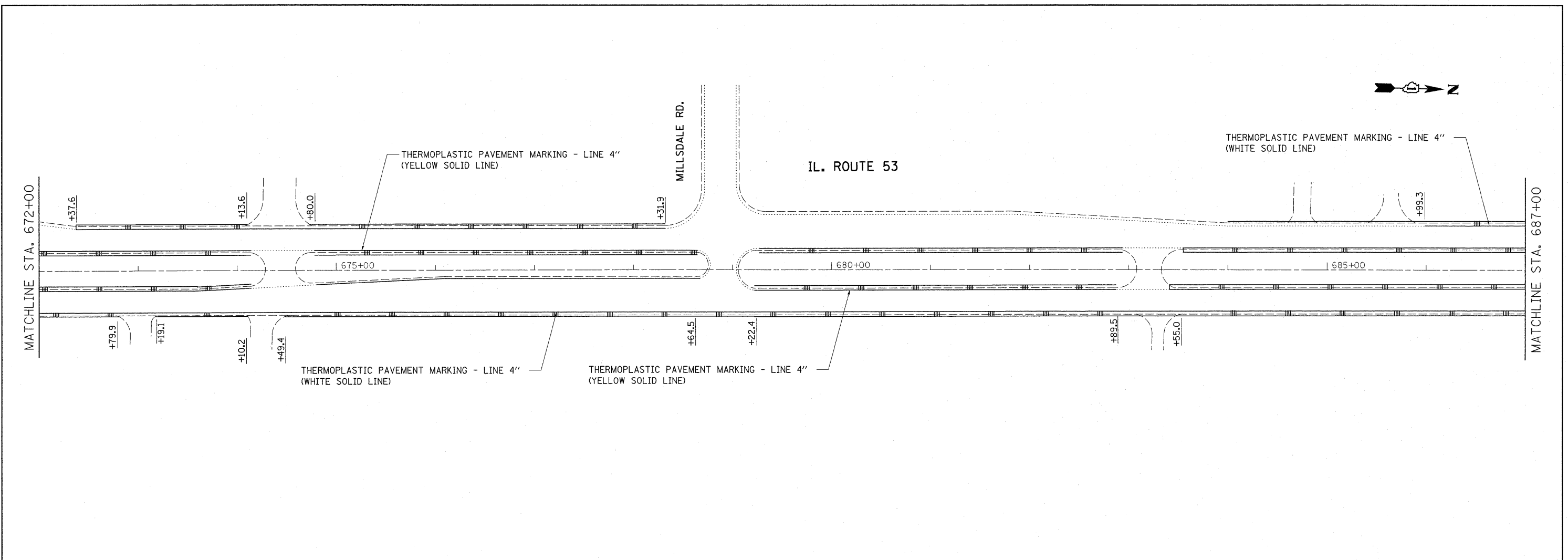

LEGEND

||| ||| PROPOSED SHOULDER RUMBLE STRIPS

FILE NAME =	USER NAME = qureshiya	DESIGNED -	REVISED -
cs:\pw\work\pw\dot\qureshiya\d0212337\012609-sht-plan.dgn		DRAWN -	REVISED -
		CHECKED -	REVISED -
		DATE -	REVISED -

**STATE OF ILLINOIS
DEPARTMENT OF TRANSPORTATION**

**ROADWAY PLAN
IL. ROUTE 53 (FORKED CREEK - US 52)**

SCALE: 1"=50' SHEET NO. OF SHEETS STA. TO STA.

F.A.P. RTE.	SECTION	COUNTY	TOTAL SHEETS	SHEET NO.
846/357	2010-133-1	WILL	54	28
CONTRACT NO. 60F75				
ILLINOIS FED. AID PROJECT				

IL. ROUTE 53

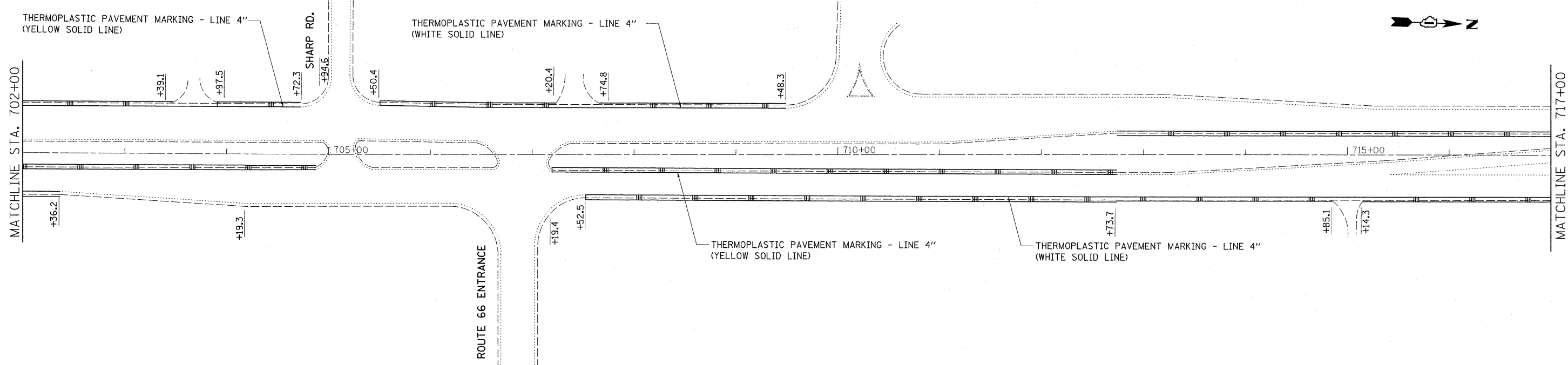

IL. ROUTE 53

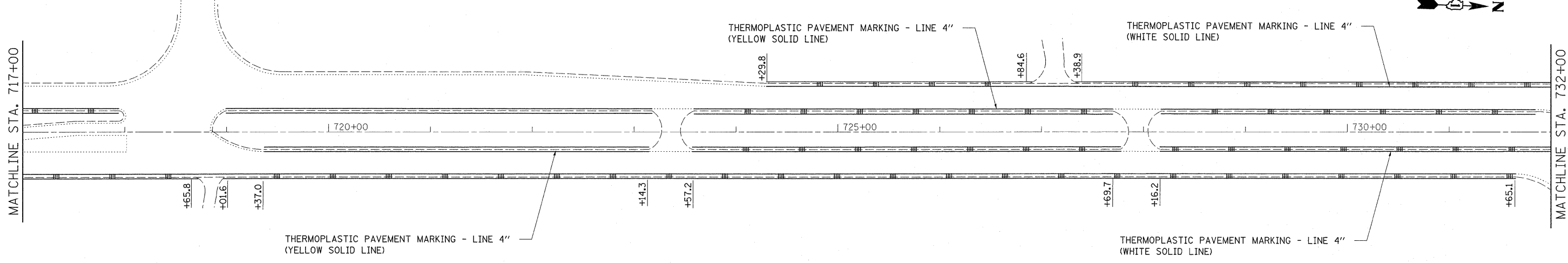

LEGEND

||| PROPOSED SHOULDER RUMBLE STRIPS

FILE NAME = c:\pwork\pwork\dot\qureshiya\d0212337\0126809-sht-plan.dgn	USER NAME = qureshiya	DESIGNED -	REVISED -	STATE OF ILLINOIS DEPARTMENT OF TRANSPORTATION	ROADWAY PLAN IL. ROUTE 53 (FORKED CREEK - US 52)			F.A.P. RTE. 846/357	SECTION 2010-133-1	COUNTY WILL	TOTAL SHEETS 54	SHEET NO. 29
	PLOT SCALE = 50.0000' / IN.	CHECKED -	REVISED -		SCALE: 1"=50'	SHEET NO.	OF	SHEETS	STA.	TO STA.	CONTRACT NO. 60F75	
	PLOT DATE = 10/28/2010	DATE -	REVISED -			ILLINOIS FED. AID PROJECT						

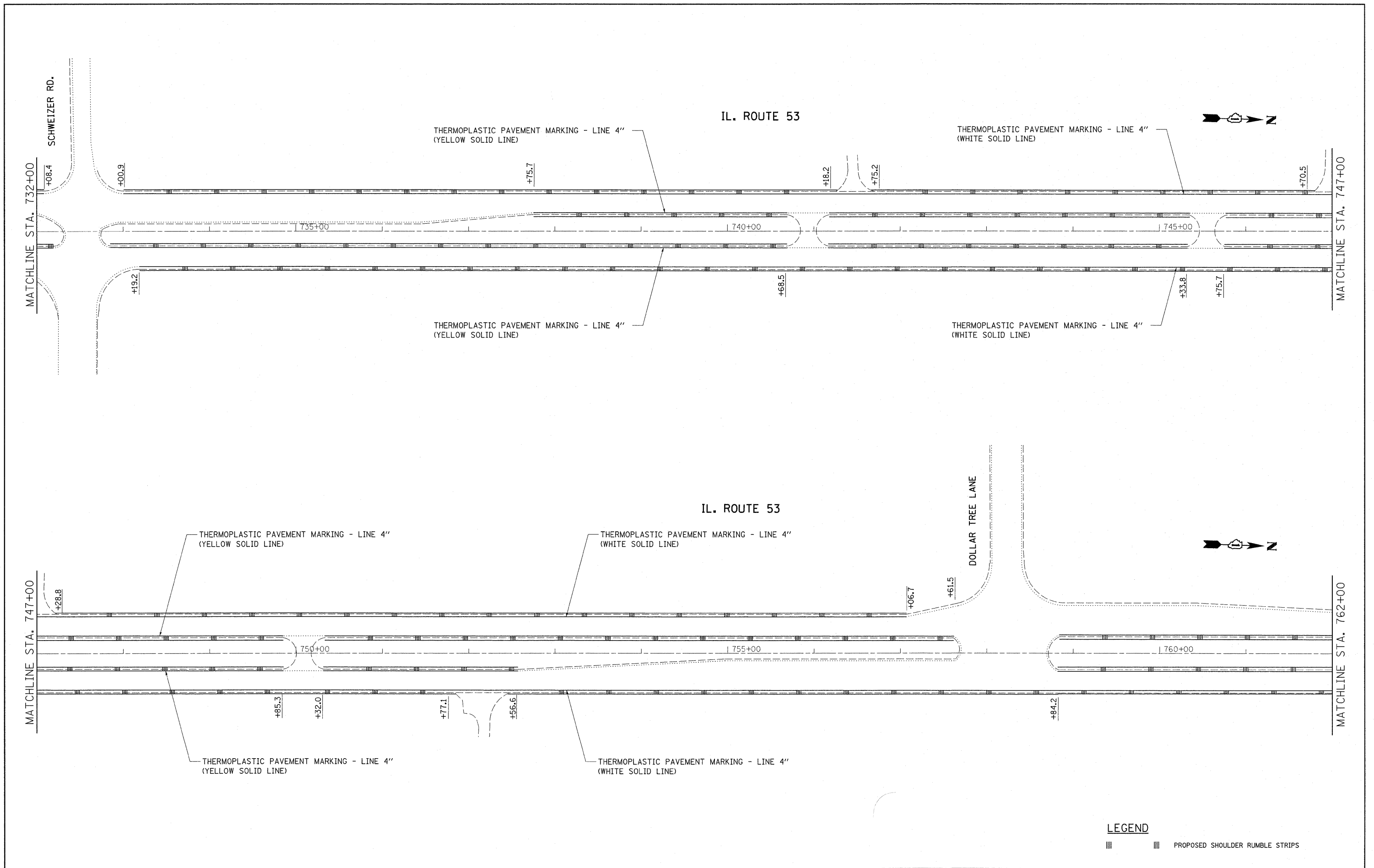

LEGEND
 |||| PROPOSED SHOULDER RUMBLE STRIPS

FILE NAME = c:\pwork\pwork\qureshiya\0212337\012609-shtrplan.dgn	USER NAME = qureshiya	DESIGNED -	REVISED -	STATE OF ILLINOIS DEPARTMENT OF TRANSPORTATION	ROADWAY PLAN IL. ROUTE 53 (FORKED CREEK - US 52)			F.A.P. RTE. 846/357	SECTION 2010-133-1	COUNTY WILL	TOTAL SHEETS 54	SHEET NO. 30	
	PLOT SCALE = 50.0000' / IN.	CHECKED -	REVISED -		SCALE: 1"=50'	SHEET NO.	OF	SHEETS	STA.	TO STA.	CONTRACT NO. 60F75		
	PLOT DATE = 10/28/2010	DATE -	REVISED -		ILLINOIS FED. AID PROJECT								

IL. ROUTE 53

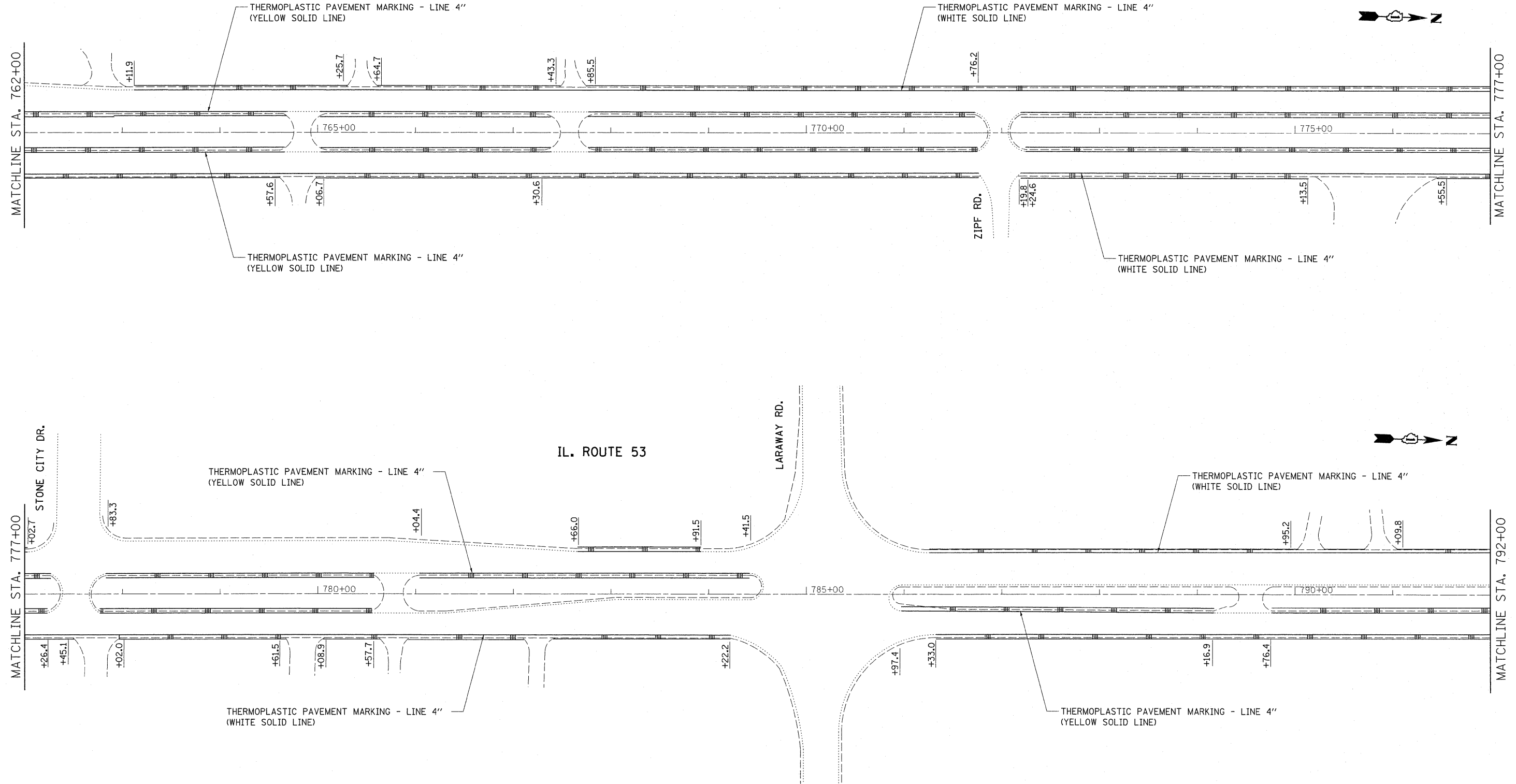

LEGEND

||| PROPOSED SHOULDER RUMBLE STRIPS

FILE NAME = c:\p\work\pvidot\qureshiya\d0212337\012609-sht-plan.dgn	USER NAME = qureshiya	DESIGNED -	REVISED -	STATE OF ILLINOIS DEPARTMENT OF TRANSPORTATION	ROADWAY PLAN IL. ROUTE 53 (FORKED CREEK - US 52)			F.A.P. RTE. 846/357	SECTION 2010-133-1	COUNTY WILL	TOTAL SHEETS 54	SHEET NO. 31	
	PLOT SCALE = 50.0000' / IN.	CHECKED -	REVISED -		SCALE: 1"=50'	SHEET NO.	OF	SHEETS	STA.	TO STA.	ILLINOIS FED. AID PROJECT		
	PLOT DATE = 10/28/2010	DATE -	REVISED -		CONTRACT NO. 60F75								

IL. ROUTE 53

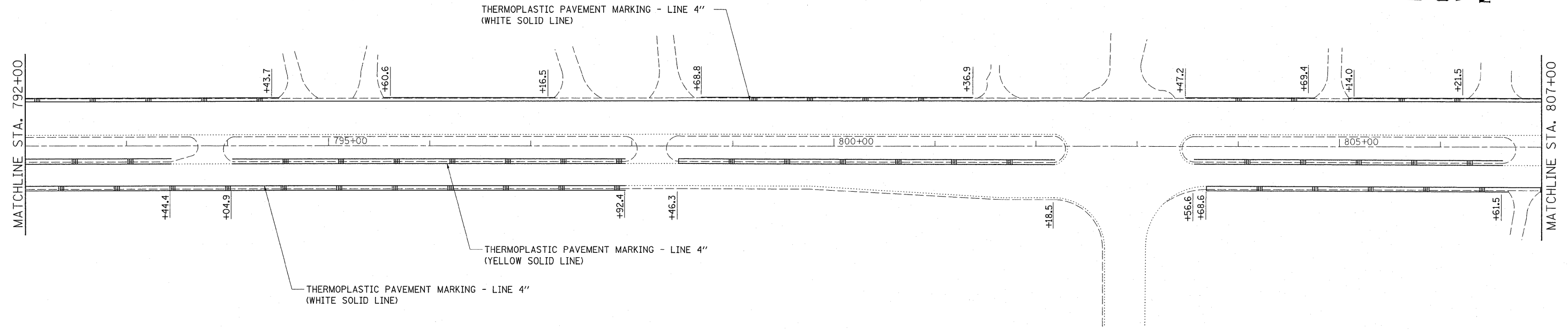

IL. ROUTE 53

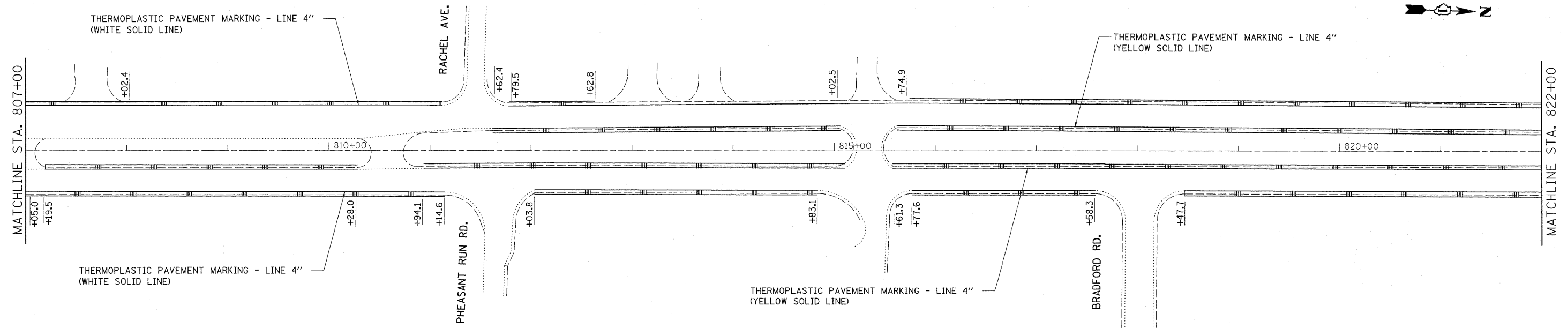
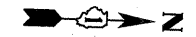

LEGEND

||| PROPOSED SHOULDER RUMBLE STRIPS

FILE NAME =	USER NAME = qureshiya	DESIGNED -	REVISED -
c:\pw\work\pw\dot\qureshiya\0212337\012609-sht-plen.dgn		DRAWN -	REVISED -
PLOT SCALE = 50.0000' / IN.		CHECKED -	REVISED -
PLOT DATE = 10/28/2010		DATE -	REVISED -

STATE OF ILLINOIS
DEPARTMENT OF TRANSPORTATION

ROADWAY PLAN			
IL. ROUTE 53 (FORKED CREEK - US 52)			
SCALE: 1"=50'	SHEET NO.	OF SHEETS	STA. TO STA.

F.A.P. RTE.	SECTION	COUNTY	TOTAL SHEETS	SHEET NO.
846/357	2010-133-1	WILL	54	32
CONTRACT NO. 60F75			ILLINOIS FED. AID PROJECT	

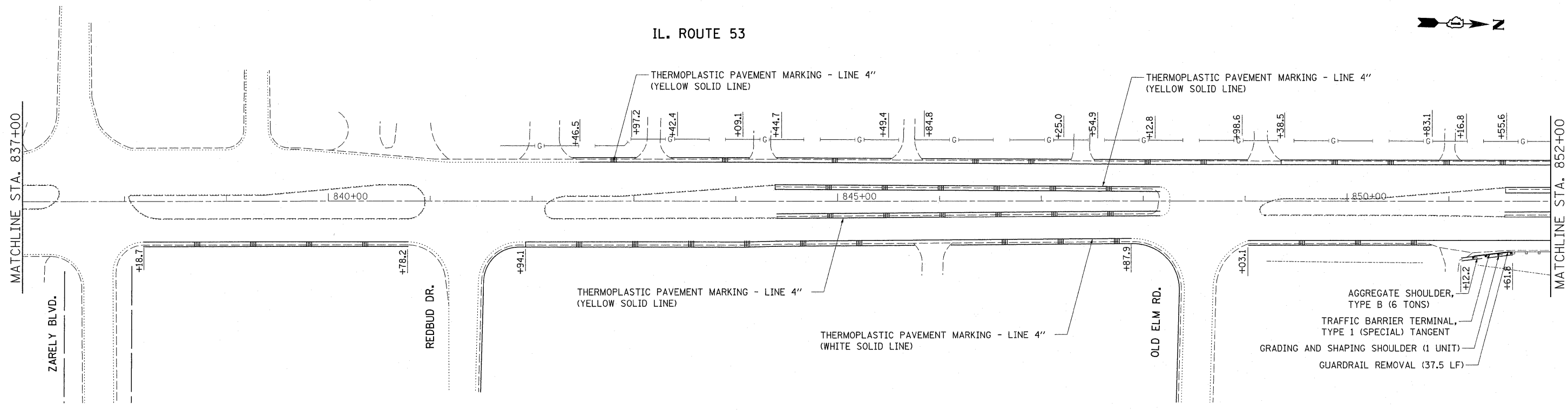
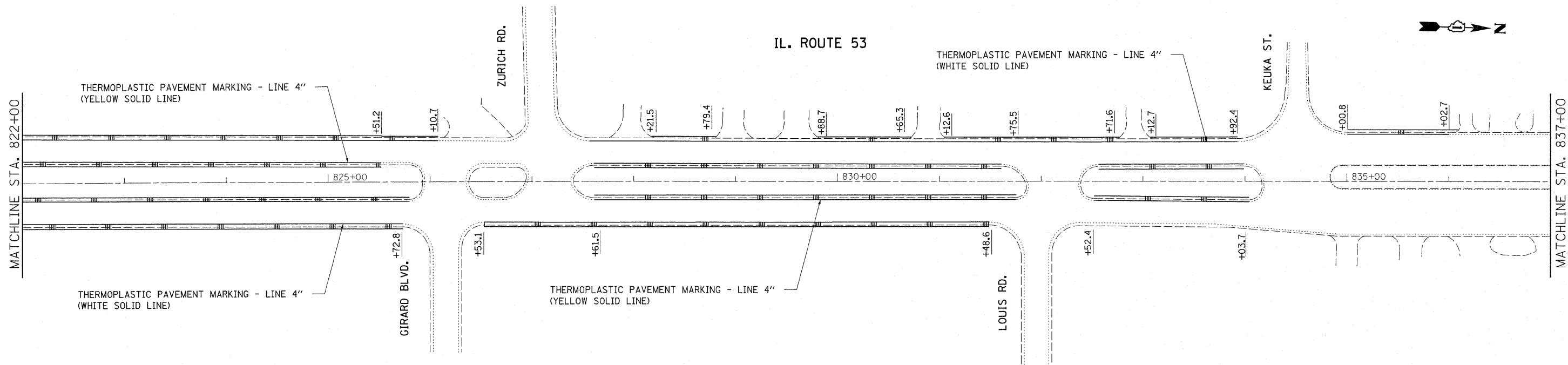

LEGEND
 |||| PROPOSED SHOULDER RUMBLE STRIPS

FILE NAME = c:\pwwork\pwwid\qureshiya\d0212337\012609-shr-pln.dgn	USER NAME = qureshiya	DESIGNED -	REVISED -	STATE OF ILLINOIS DEPARTMENT OF TRANSPORTATION	ROADWAY PLAN			F.A.P. RTE. =	SECTION	COUNTY	TOTAL SHEETS	SHEET NO.
	PLOT SCALE = 50.0000' / IN.	DRAWN -	REVISED -		IL. ROUTE 53 (FORKED CREEK - US 52)			846/357	2010-133-I	WILL	54	33
	PLOT DATE = 10/28/2010	CHECKED -	REVISED -		SCALE: 1"=50' SHEET NO. OF SHEETS STA. TO STA.			CONTRACT NO. 60F75				
		DATE -	REVISED -		ILLINOIS FED. AID PROJECT							

IL. ROUTE 53

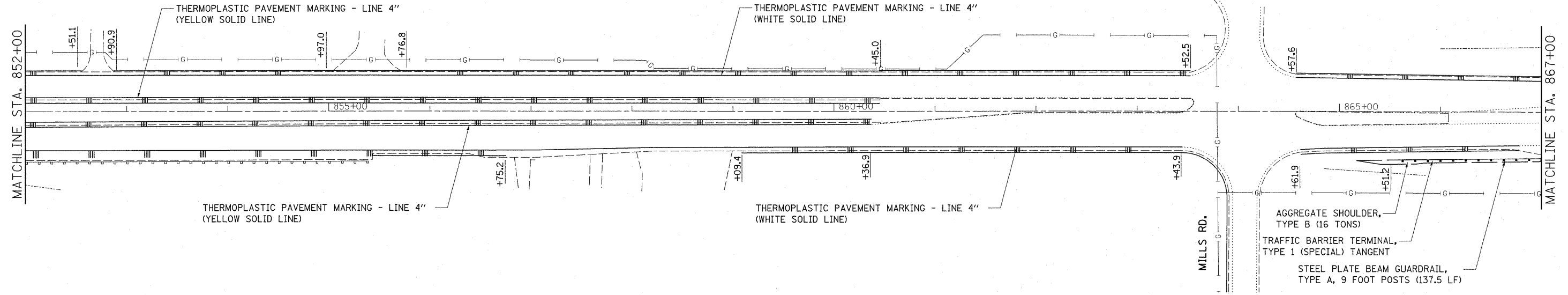

IL. ROUTE 53

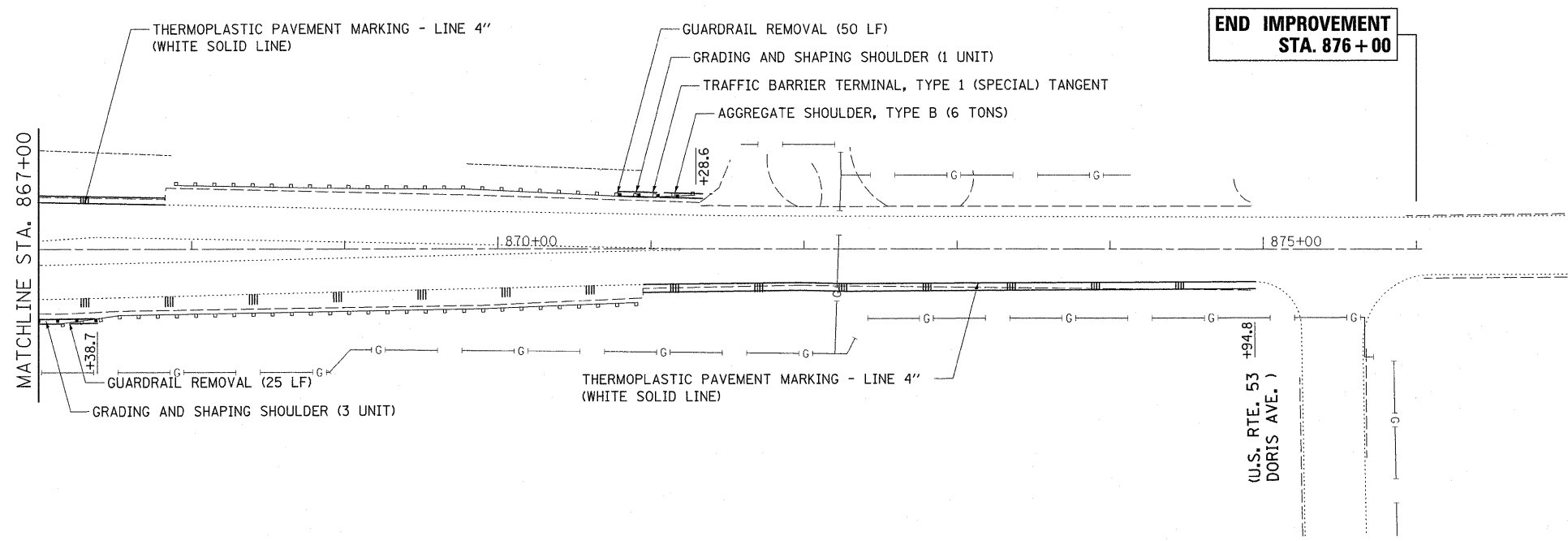

LEGEND

||| PROPOSED SHOULDER RUMBLE STRIPS

FILE NAME =	USER NAME = qureshiya	DESIGNED -	REVISED -
ct:\pw\work\p\dot\qureshiya\d0212337\0122609-sht-plan.dgn		DRAWN -	REVISED -
PLOT SCALE = 50.0000' / IN.		CHECKED -	REVISED -
PLOT DATE = 10/28/2010		DATE -	REVISED -

STATE OF ILLINOIS
DEPARTMENT OF TRANSPORTATION

ROADWAY PLAN			
IL. ROUTE 53 (FORKED CREEK - US 52)			
SCALE: 1"=50'	SHEET NO.	OF SHEETS	STA. TO STA.

F.A.P. RTE.	SECTION	COUNTY	TOTAL SHEETS	SHEET NO.
846/357	2010-133-1	WILL	54	34
CONTRACT NO. 60F75				
ILLINOIS FED. AID PROJECT				

TRAFFIC SIGNAL LEGEND

	PROPOSED	EXISTING
CONTROLLER		
SERVICE INSTALLATION		
SIGNAL HEAD		
SIGNAL HEAD WITH BACKPLATE		
SIGNAL HEAD, PEDESTRIAN WITH TIMER		
SIGNAL POST		
MAST ARM ASSEMBLY AND POLE, STEEL		
MAST ARM ASSEMBLY AND POLE, ALUMINUM		
COMMON TRENCH		
UNIT DUCT		
HANDHOLE		
HEAVY DUTY HANDHOLE		
DOUBLE HANDHOLE		
G.S. CONDUIT IN TRENCH OR PUSHED		
PEDESTRIAN PUSHBUTTON DETECTOR		
DETECTOR LOOP		
CAST IRON JUNCTION BOX		
EMERGENCY VEHICLE SYSTEM DETECTOR		
CONFIRMATION BEACON		
SIGNAL HEAD OPTICALLY PROGRAMMED		
CONDUIT SPLICE		
WOOD POLE		
RACEWAY FOR MAGNETIC DETECTOR, TYPE I OR TYPE II		
VEHICLE DETECTOR, NON COMPENSATED MAGNETIC TYPE		
RAILROAD CONTROLLER		
ILLUMINATED SIGN, FIBER OPTIC "NO LEFT TURN"		
ILLUMINATED SIGN, FIBER OPTIC "NO RIGHT TURN"		
TELEPHONE CONNECTION		
LUMINAIRE		

THE FOLLOWING ITEMS SHALL BE REMOVED BY THE CONTRACTOR AND SHALL BE DISPOSED OF BY THEM OUTSIDE THE RIGHT-OF-WAY AT THEIR EXPENSE. THE SALVAGE VALUE OF THE REMOVED EQUIPMENT SHALL BE REFLECTED IN THE CONTRACT BID PRICE.

- 2 EACH SIGNAL HEAD, 1-FACE, 3-SECTION BRACKET MOUNTED
- 2 EACH SIGNAL HEAD, 1-FACE, 3-SECTION MAST ARM MOUNTED
- 2 EACH SIGNAL HEAD, 1-FACE, 5-SECTION BRACKET MOUNTED
- 2 EACH SIGNAL HEAD, 1-FACE, 5-SECTION MAST ARM MOUNTED
- 4 EACH TRAFFIC SIGNAL POST
- 6 EACH CONCRETE FOUNDATION
- 4 EACH TRAFFIC SIGNAL BACKPLATE
- 1 EACH POLE MOUNTED ELECTRIC SERVICE
- 2 EACH MAST ARM ASSEMBLY & POLE
- 4 EACH PAINTED SIGNAL POSTS

EXISTING EQUIPMENT TO BE REMOVED LEGEND

	EXISTING CONTROLLER TO BE REMOVED
	EXISTING SERVICE INSTALLATION TO BE REMOVED
	EXISTING SIGNAL HEAD TO BE REMOVED
	EXISTING SIGNAL HEAD WITH BACKPLATE TO BE REMOVED
	EXISTING PEDESTRIAN SIGNAL HEAD TO BE REMOVED
	EXISTING SIGNAL POST TO BE REMOVED
	EXISTING STEEL MAST ARM POLE AND FOUNDATION TO BE REMOVED
	EXISTING ALUMINUM MAST ARM POLE AND FOUNDATION TO BE REMOVED
	EXISTING HANDHOLE TO BE REMOVED
	EXISTING HEAVY DUTY HANDHOLE TO BE REMOVED
	EXISTING PEDESTRIAN PUSHBUTTON TO BE REMOVED
	EXISTING EMERGENCY VEHICLE SYSTEM DETECTOR TO BE REMOVED
	EXISTING CONFIRMATION BEACON TO BE REMOVED

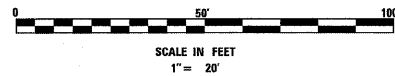

ALL EXISTING SIGNAL HEADS TO BE REPLACED WITH LED SIGNAL HEADS

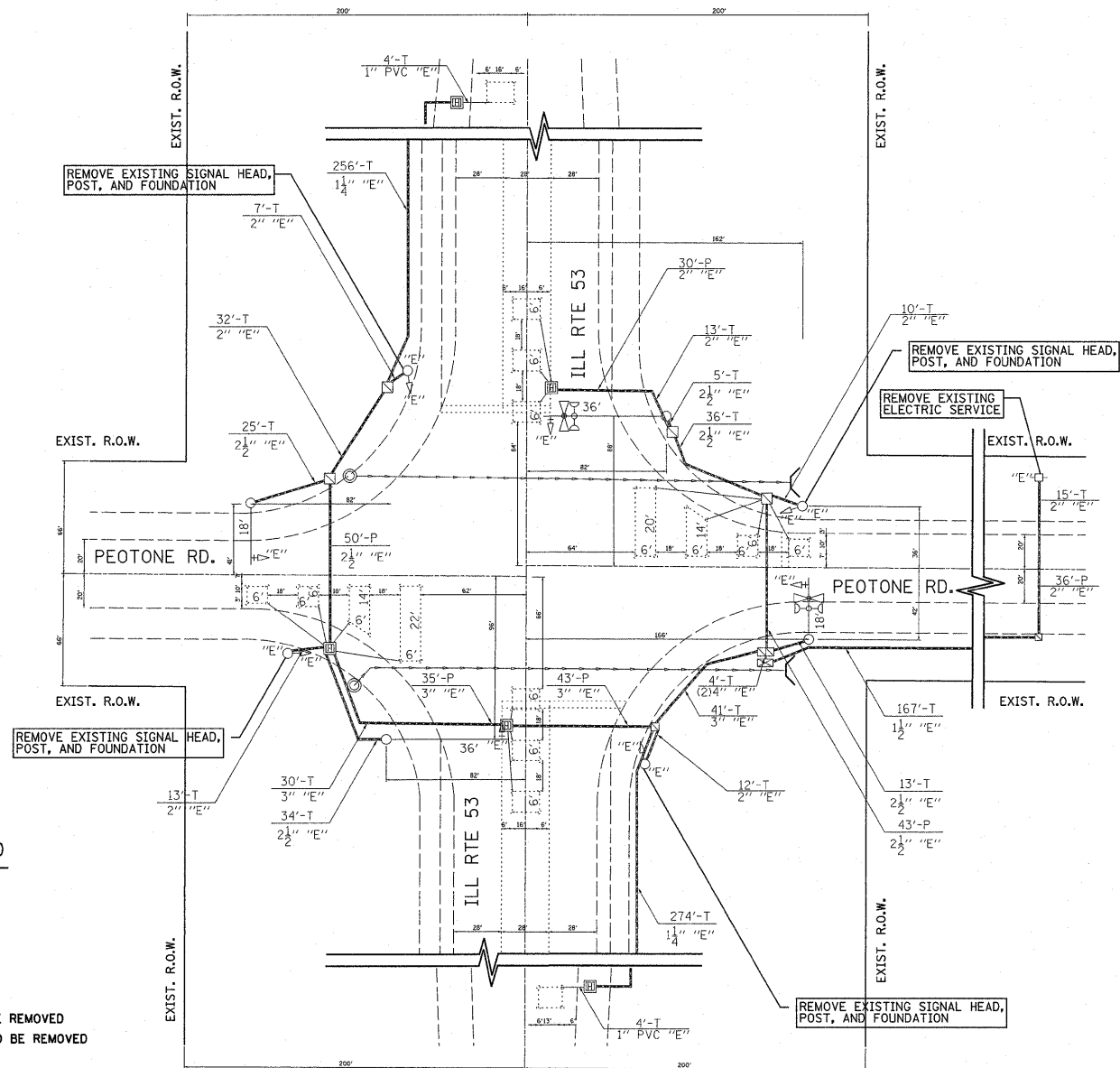

TRAFFIC SIGNAL REMOVAL PLAN
ILL 53 AT PEOTONE ROAD

FILE NAME =	USER NAME = qureshiya	DESIGNED -	REVISED -	STATE OF ILLINOIS DEPARTMENT OF TRANSPORTATION	TRAFFIC SIGNAL REMOVAL PLAN ILL 53 AT PEOTONE RD			F.A.P. RTE.	SECTION	COUNTY	TOTAL SHEETS	SHEET NO.	
c:\pwork\pwork\qureshiya\0212316\0124609-sht-plen.dgn		DRAWN -	REVISED -		SCALE: NTS	SHEET NO. 1 OF 3 SHEETS	STA. TO STA.	• 846/357	2010-133-1	WILL	54	35	
		CHECKED -	REVISED -										
		DATE -	REVISED -										
								CONTRACT NO. 60F75					
								ILLINOIS FED. AID PROJECT					

TRAFFIC SIGNAL LEGEND

	PROPOSED	EXISTING
CONTROLLER		
SERVICE INSTALLATION		
SIGNAL HEAD		
SIGNAL HEAD WITH BACKPLATE		
SIGNAL HEAD, PEDESTRIAN WITH TIMER		
SIGNAL POST		
MAST ARM ASSEMBLY AND POLE, STEEL		
MAST ARM ASSEMBLY AND POLE, ALUMINUM		
COMMON TRENCH		
UNIT DUCT		
HANDHOLE		
HEAVY DUTY HANDHOLE		
DOUBLE HANDHOLE		
G.S. CONDUIT IN TRENCH OR PUSHED		
PEDESTRIAN PUSHBUTTON DETECTOR		
DETECTOR LOOP		
CAST IRON JUNCTION BOX		
EMERGENCY VEHICLE SYSTEM DETECTOR		
CONFIRMATION BEACON		
SIGNAL HEAD OPTICALLY PROGRAMMED		
CONDUIT SPLICE		
WOOD POLE		
RACEWAY FOR MAGNETIC DETECTOR, TYPE I OR TYPE II		
VEHICLE DETECTOR, NON COMPENSATED MAGNETIC TYPE		
RAILROAD CONTROLLER		
ILLUMINATED SIGN, FIBER OPTIC "NO LEFT TURN"		
ILLUMINATED SIGN, FIBER OPTIC "NO RIGHT TURN"		
TELEPHONE CONNECTION		
LUMINAIRE		

DETAIL "A"

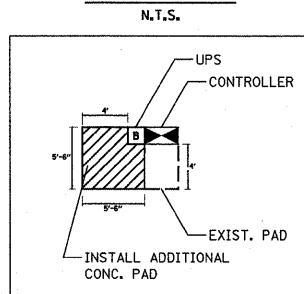

- 1) 5" THICK CONCRETE PAD SHALL BE POURED NEXT TO NEW CONTROLLER AND/OR UPS TO PROVIDE EASY MAINTENANCE ACCESS.
- 2) MAINTENANCE PAD SHALL EXTEND TO THE EDGE OF EXISTING CONTROLLER FOUNDATION.
- 3) COST OF PAD SHALL BE INCLUDED IN THE PRICE OF THE UNINTERRUPTIBLE POWER SUPPLY PAY ITEM.

ALL EXISTING SIGNAL HEADS TO BE REPLACED WITH LED SIGNAL HEADS

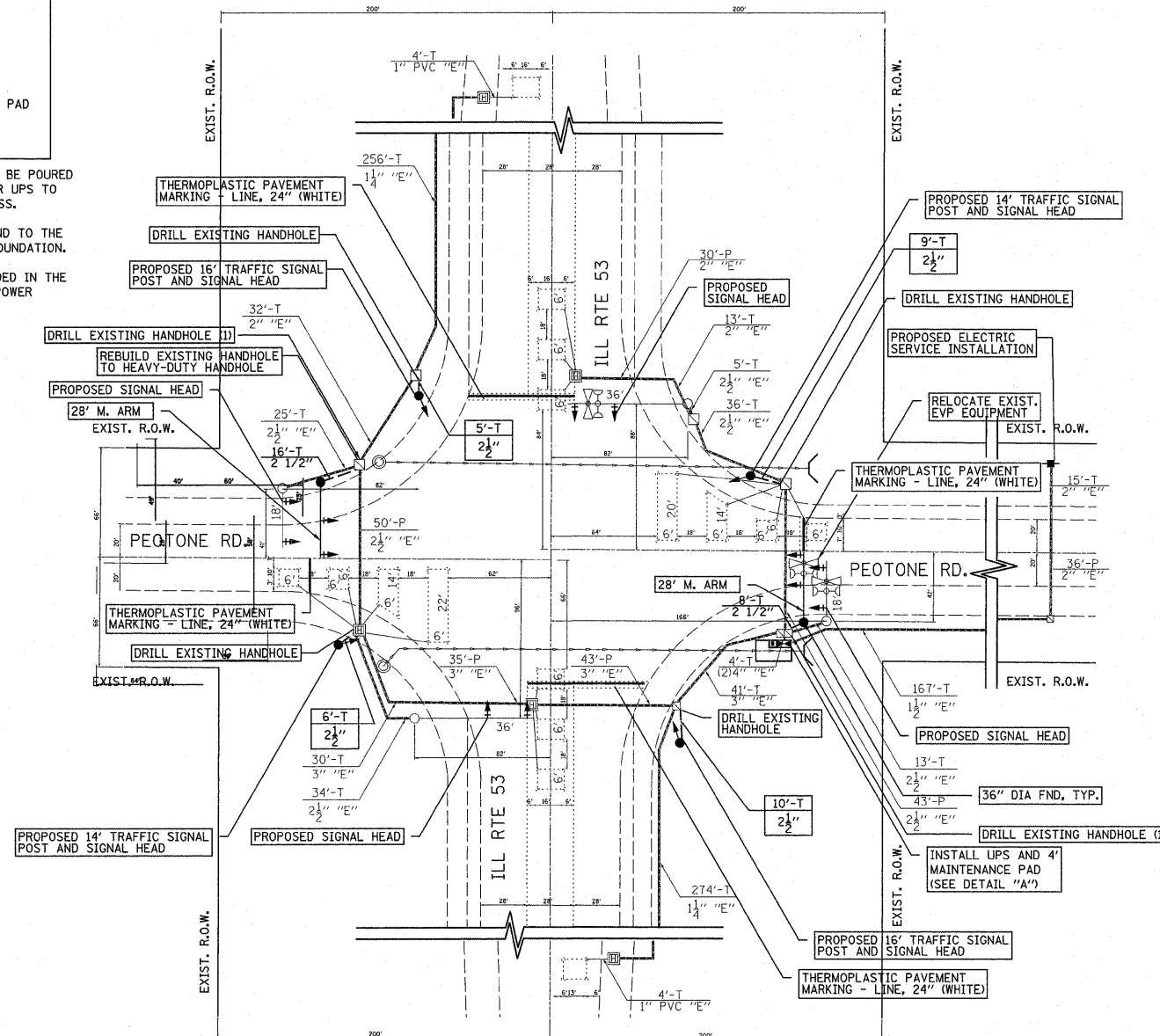

NOTE:
THE CONTRACTOR SHALL BE REQUIRED TO MAINTAIN THE OPERATION OF THE TRAFFIC SIGNALS DURING THE ENTIRE PROJECT.

NOTE:
THE FINAL LOCATION OF THE SIGNAL POSTS WILL BE DETERMINED IN THE FIELD AND THE CONTRACTOR SHALL VERIFY THE LOCATION WITH THE RESIDENT ENGINEER.

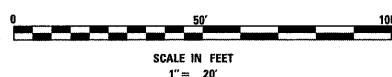

**TRAFFIC SIGNAL MODIFICATION PLAN
IL 53 AT PEOTONE ROAD**

1" = 20'

FILE NAME =	USER NAME = qureshiya	DESIGNED -	REVISED -	STATE OF ILLINOIS DEPARTMENT OF TRANSPORTATION	TRAF SIGNAL MODIFICATION PLAN IL 53 AT PEOTONE RD	F.A.P. RTE.	SECTION	COUNTY	TOTAL SHEETS	SHEET NO.	
ca:\pw_work\pwi\dot\qureshiya\d0212316\012	609-sh-t-plen.dgn	DRAWN -	REVISED -			*	2010-133-1	WILL	54	36	
	PLOT SCALE = 50.0000' / IN.	CHECKED -	REVISED -			* 846/357					CONTRACT NO. 60F75
	PLOT DATE = 10/28/2010	DATE -	REVISED -								ILLINOIS FED. AID PROJECT

CABLE PLAN LEGEND

EXISTING	PROPOSED	
		8" (200mm) TRAFFIC SIGNAL SECTION
		12" (300mm) TRAFFIC SIGNAL SECTION
		12" (300mm) PEDESTRIAN SIGNAL SECTION
		12" (300mm) PEDESTRIAN SIGNAL SECTION
		CONTROLLER CABINET
		SERVICE INSTALLATION
		TELEPHONE CONNECTION
		MAGNETIC DETECTOR
		EMERGENCY VEHICLE LIGHT DETECTOR
		CONFIRMATION BEACON
		PUSHBUTTON DETECTOR
		VEHICLE DETECTOR, INDUCTION LOOP
		DENOTES NUMBER OF CONDUCTORS, ALL CABLE NO. 14 EXCEPT AS INDICATED. ALL LOOP DETECTOR CABLE TO BE SHIELDED.
		MICROWAVE VEHICLE SENSOR
		SIGNAL FACE WITH BACKPLATE, "P" INDICATES PROGRAMMED HEAD
		RAILROAD CONTROL CABINET
		ILLUMINATED SIGN, FIBER OPTIC "NO LEFT TURN"
		ILLUMINATED SIGN, FIBER OPTIC "NO RIGHT TURN"
		GROUND ROD AT HANDHOLE (H), DOUBLE HANDHOLE (H), OR CONTROLLER (C).
		GROUND ROD AT POST (P), OR MAST ARM POLE (MA).
		GROUND ROD AT ELECTRIC SERVICE INSTALLATION
		GROUND CABLE IN CONDUIT NO. 6 SOLID COPPER (GREEN)
		FIBER OPTIC CABLE IN CONDUIT NO. 62.5/125 MM12F SM12F
		12" (300mm) PEDESTRIAN SIGNAL SECTION WITH COUNTDOWN TIMER
		UNINTERRUPTIBLE POWER SUPPLY

CONTROLLER SEQUENCE IV
REFERRING TO STANDARD 2393-1, THE VEHICULAR AND PEDESTRIAN PHASES USED ARE DESIGNATED BELOW.

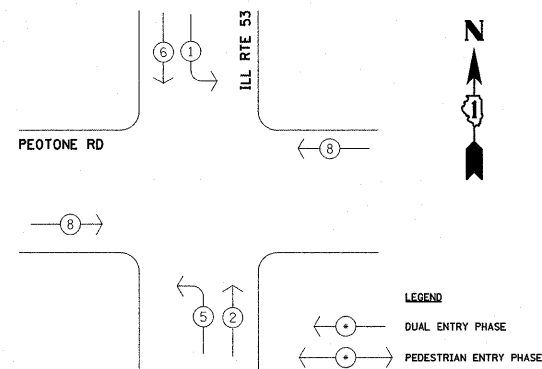

PHASE DESTINATION DIAGRAM

EMERGENCY VEHICLE PREEMPTION SEQUENCE

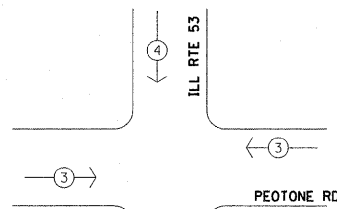

EMERGENCY VEHICLE PREEMPTOR	3	4
MOVEMENT		

PROPOSED CABLE PLAN

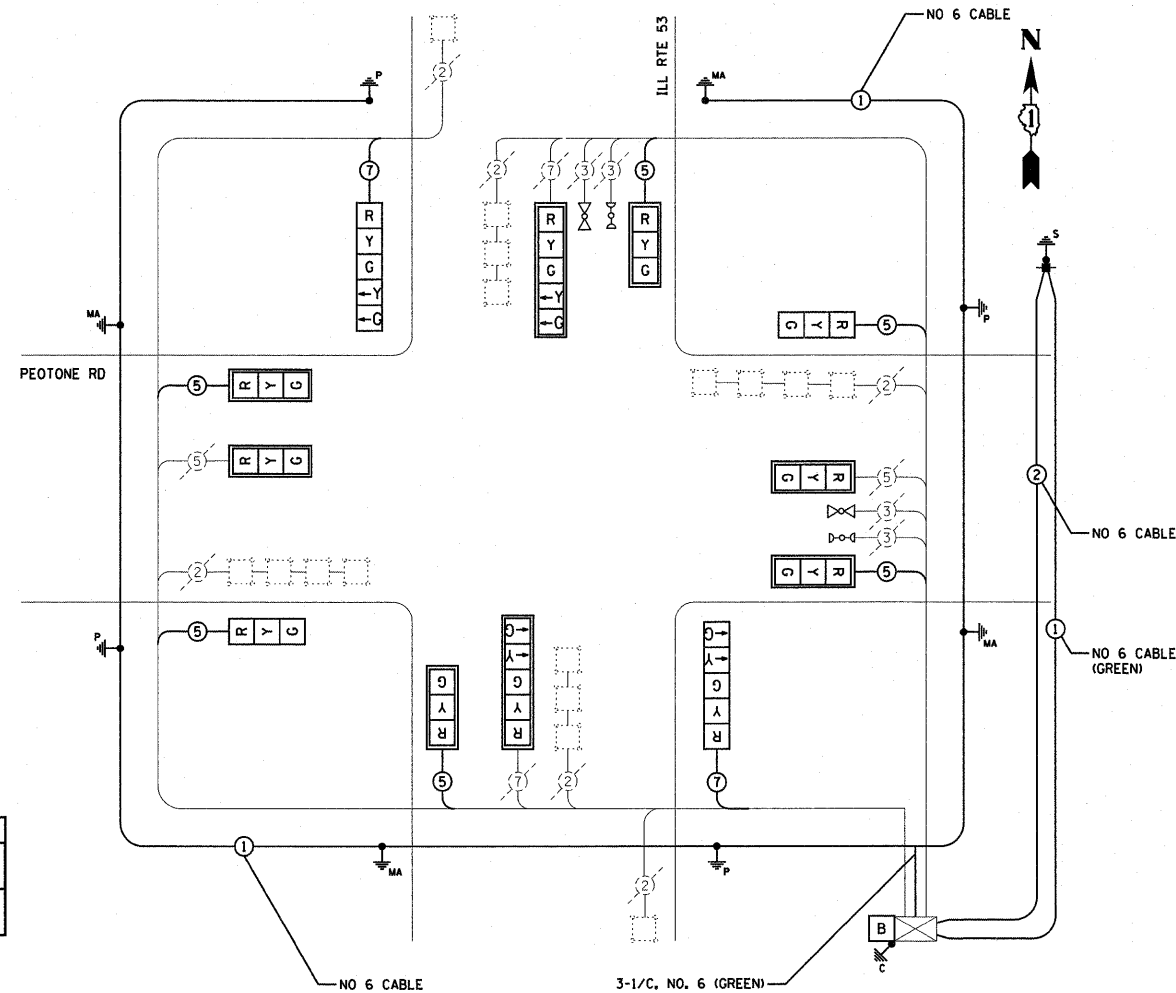

NOTE:
EQUIPMENT GROUND CONDUCTOR (GREEN COLOR CODED) SPLICE TO FRAME AND COVER IS REQUIRED FOR ALL HANDHOLES OR DOUBLE HANDHOLES THAT CARRY SIGNAL CABLES AND SERVICE CABLES.

TYPE	NO. LAMPS	WATTAGE		% OPERATION	TOTAL WATTAGE
		INCAND.	LED		
SIGNAL (RED)	12	135	17	0.50	102.00
(YELLOW)	12	135	25	0.25	75.00
(GREEN)	12	135	15	0.25	45.00
ARROW	8	135	12	0.10	9.60
PED. SIGNAL	0	90	25	1.00	0.00
CONTROLLER	1	100	100	1.00	100.00

FOUNDATION (DEPTH)	FT. (m)	CABLE SLACK	FT. (m)	FT. (m)
TYPE A - POST	4 (1.2)	HANDHOLE	6.5 (2.0)	ALL FOUNDATIONS
D - CONTROLLER	4 (1.2)	DOUBLE HANDHOLE	13 (4.0)	MAST ARM (L) POLE
E - M. ARM POLE	2 (0.6)	SIGNAL POST	2 (0.6)	20'-H-2"
24" (600mm)	10 (3.0)	CONTROLLER CAB.	1 (0.5)	BRACKET MOUNTED
30" (750mm)	15 (4.6)	FIBER OPTIC	13 (4.0)	PED. PUSHBUTTON
		ELECTRIC SERVICE	1 (0.5)	ELECTRIC SERVICE
		GROUND CABLE	1 (0.5)	SERVICE TO GROUND
				POST MOUNTED

CODE #	DESCRIPTION	UNIT	QUANTITY
78000650	THERMOPLASTIC PAVEMENT MARKING - LINE 24"	FOOT	95
78300400	THERMOPLASTIC PAVEMENT MARKING REMOVAL	SQ. FT.	185
81000700	CONDUIT IN TRENCH, 2 1/2" DIA., GALVANIZED STEEL	FOOT	54
81900200	TRENCH AND BACKFILL FOR ELECTRICAL WORK	FOOT	30
85000200	MAINTENANCE OF EXISTING TRAFFIC SIGNAL INSTALLATION	EACH	1
87301245	ELECTRIC CABLE IN CONDUIT, SIGNAL NO. 14 5C	FOOT	1,500
87301255	ELECTRIC CABLE IN CONDUIT, SIGNAL NO. 14 7C	FOOT	400
87301805	ELECTRIC CABLE IN CONDUIT, SERVICE, NO. 6 2 C	FOOT	200
87502480	TRAFFIC SIGNAL POST, GALVANIZED STEEL 14 FT.	EACH	2
87502500	TRAFFIC SIGNAL POST, GALVANIZED STEEL 16 FT.	EACH	2
87800115	CONCRETE FOUNDATION, TYPE A	EACH	4
87900200	DRILL EXISTING HANDHOLE	EACH	6
88030020	SIGNAL HEAD, LED, 1-FACE, 3-SECTION, MAST-ARM MOUNTED	EACH	6

CODE #	DESCRIPTION	UNIT	QUANTITY
88030050	SIGNAL HEAD, LED, 1-FACE, 3-SECTION, BRACKET MOUNTED	EACH	2
88030100	SIGNAL HEAD, LED, 1-FACE, 5-SECTION, BRACKET MOUNTED	EACH	2
88030110	SIGNAL HEAD, LED, 1-FACE, 5-SECTION, MAST-ARM MOUNTED	EACH	2
88200210	TRAFFIC SIGNAL BACKPLATE, LOUVERED, ALUMINUM	EACH	8
89502300	REMOVE ELECTRIC CABLE FROM CONDUIT	FOOT	820
89502375	REMOVE EXISTING TRAFFIC SIGNAL EQUIPMENT	EACH	1
89502385	REMOVE EXISTING CONCRETE FOUNDATION	EACH	6
X8050015	SERVICE INSTALLATION - POLE MOUNTED	EACH	1
X8140074	GROUNDING EXISTING HANDHOLE FRAME AND COVER	EACH	9
X8620020	UNINTERRUPTIBLE POWER SUPPLY	EACH	1
X8730027	ELECTRIC CABLE IN CONDUIT, GROUNDING, NO. 6 1C	FOOT	900
X8950210	REBUILD EXISTING HANDHOLE TO HEAVY-DUTY HANDHOLE	EACH	1
87700180	STEEL MAST ARM ASSEMBLY & POLE, 28 FT.	EACH	2
87800400	CONCRETE FOUNDATION, TYPE E 30-INCH DIA.	FOOT	20
89501400	RELOCATE EXIST EMER VEHICLE PRIORITY SYS, DET UNIT	EACH	1
87301225	ELECTRIC CABLE IN CONDUIT, SIGNAL NO.14 3C	FOOT	80
X8730250	ELECTRIC CABLE IN CONDUIT NO.20 3/C, TWISTED SHIELDED	FOOT	80

CABLE PLAN, PHASE DESIGNATION DIAGRAM, SCHEDULE OF QUANTITIES IL 53 AT PEOTONE ROAD

SCALE: NTS SHEET NO. 3 OF 3 SHEETS STA. TO STA.

FILE NAME =	USER NAME = qureshshya	DESIGNED -	REVISED -	STATE OF ILLINOIS DEPARTMENT OF TRANSPORTATION	CABLE PLAN, PHASE DESIGNATION DIAGRAM, SCHEDULE OF QUANTITIES, IL 53 AT PEOTONE ROAD	F.A.P. RTE.	SECTION	COUNTY	TOTAL SHEETS	SHEET NO.
ca:\pwwork\pwws\dot\qureshshya\d0212315\122609-shs-plan.dgn	PLOT SCALE = 50.0000' / IN.	DRAWN -	REVISED -			•	2010-133-I	WILL	54	37
	PLOT DATE = 10/27/2018	CHECKED -	REVISED -			•	846/357			
		DATE -	REVISED -					ILLINOIS FED. AID PROJECT		

ALL EXISTING SIGNAL HEADS TO BE REPLACED WITH LED SIGNAL HEADS

- EXISTING CONTROLLER TO BE REMOVED
- EXISTING SERVICE INSTALLATION TO BE REMOVED
- EXISTING SIGNAL HEAD TO BE REMOVED
- EXISTING SIGNAL HEAD WITH BACKPLATE TO BE REMOVED
- EXISTING PEDESTRIAN SIGNAL HEAD TO BE REMOVED
- EXISTING SIGNAL POST TO BE REMOVED
- EXISTING STEEL MAST ARM POLE AND FOUNDATION TO BE REMOVED
- EXISTING ALUMINUM MAST ARM POLE AND FOUNDATION TO BE REMOVED
- EXISTING HANDHOLE TO BE REMOVED
- EXISTING HEAVY DUTY HANDHOLE TO BE REMOVED
- EXISTING PEDESTRIAN PUSHBUTTON TO BE REMOVED
- EXISTING EMERGENCY VEHICLE SYSTEM DETECTOR TO BE REMOVED
- EXISTING CONFIRMATION BEACON TO BE REMOVED

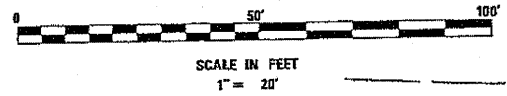
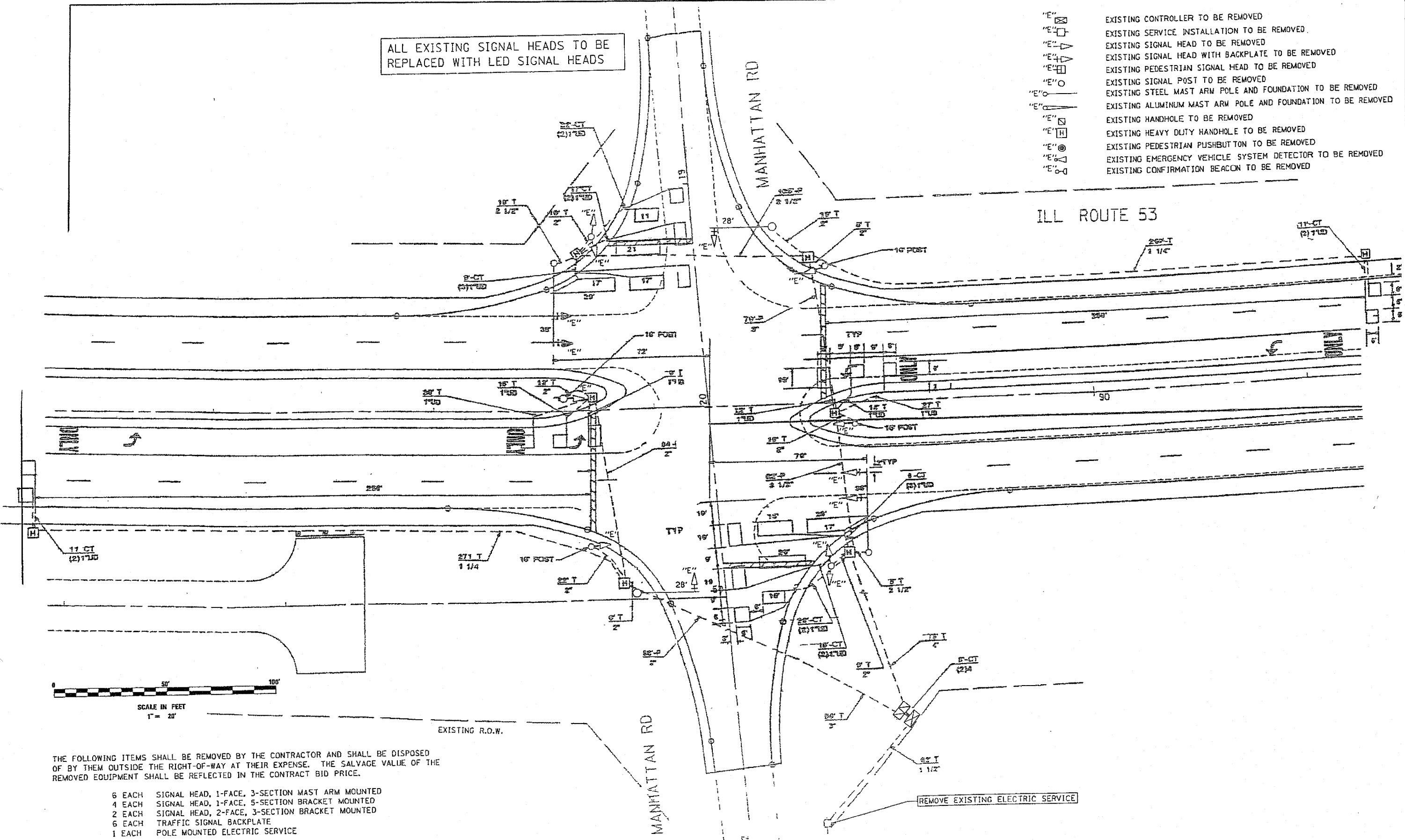

THE FOLLOWING ITEMS SHALL BE REMOVED BY THE CONTRACTOR AND SHALL BE DISPOSED OF BY THEM OUTSIDE THE RIGHT-OF-WAY AT THEIR EXPENSE. THE SALVAGE VALUE OF THE REMOVED EQUIPMENT SHALL BE REFLECTED IN THE CONTRACT BID PRICE.

- 6 EACH SIGNAL HEAD, 1-FACE, 3-SECTION MAST ARM MOUNTED
- 4 EACH SIGNAL HEAD, 1-FACE, 5-SECTION BRACKET MOUNTED
- 2 EACH SIGNAL HEAD, 2-FACE, 3-SECTION BRACKET MOUNTED
- 6 EACH TRAFFIC SIGNAL BACKPLATE
- 1 EACH POLE MOUNTED ELECTRIC SERVICE

REMOVE EXISTING ELECTRIC SERVICE

FILE NAME =	USER NAME = qureshiga	DESIGNED -	REVISED -	STATE OF ILLINOIS DEPARTMENT OF TRANSPORTATION	TRAFFIC SIGNAL REMOVAL PLAN IL 53 AT MANHATTAN RD	F.A.P. RTE.	SECTION	COUNTY	TOTAL SHEETS	SHEET NO.
ct:\pwwork\pwwork\qureshiga\08212316\012	689-ahc-plan.dgn	DRAWN -	REVISED -			846/357	2010-133-1	WILL	54	38
PLOT SCALE = 1/8" = 1'	CHECKED -	REVISED -	REVISED -			CONTRACT NO. 60F75				
PLOT DATE = 10/27/2010	DATE -	REVISED -	REVISED -			ILLINOIS FED. AID PROJECT				
					SCALE: NTS	SHEET NO. 1 OF 3 SHEETS		STA.	TO STA.	

TRAFFIC SIGNAL LEGEND

	PROPOSED	EXISTING
CONTROLLER		
SERVICE INSTALLATION		
SIGNAL HEAD		
SIGNAL HEAD WITH BACKPLATE		
SIGNAL HEAD, PEDESTRIAN WITH TIMER		
SIGNAL POST		
MAST ARM ASSEMBLY AND POLE, STEEL		
MAST ARM ASSEMBLY AND POLE, ALUMINUM		
COMMON TRENCH		
UNIT DUCT		
HANDHOLE		
HEAVY DUTY HANDHOLE		
DOUBLE HANDHOLE		
G.S. CONDUIT IN TRENCH OR PUSHED		
PEDESTRIAN PUSHBUTTON DETECTOR		
DETECTOR LOOP		
CAST IRON JUNCTION BOX		

ALL EXISTING SIGNAL HEADS TO BE REPLACED WITH LED SIGNAL HEADS

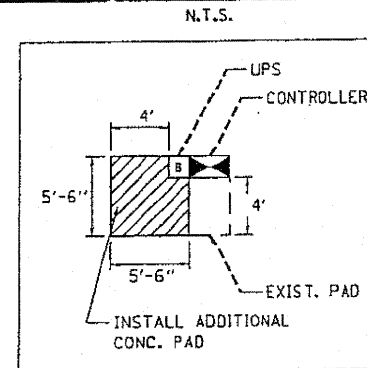

- 1) 5" THICK CONCRETE PAD SHALL BE POURED NEXT TO NEW CONTROLLER AND/OR UPS TO PROVIDE EASY MAINTENANCE ACCESS.
- 2) MAINTENANCE PAD SHALL EXTEND TO THE EDGE OF EXISTING CONTROLLER FOUNDATION.
- 3) COST OF PAD SHALL BE INCLUDED IN THE PRICE OF THE UNINTERRUPTIBLE POWER SUPPLY PAY ITEM.

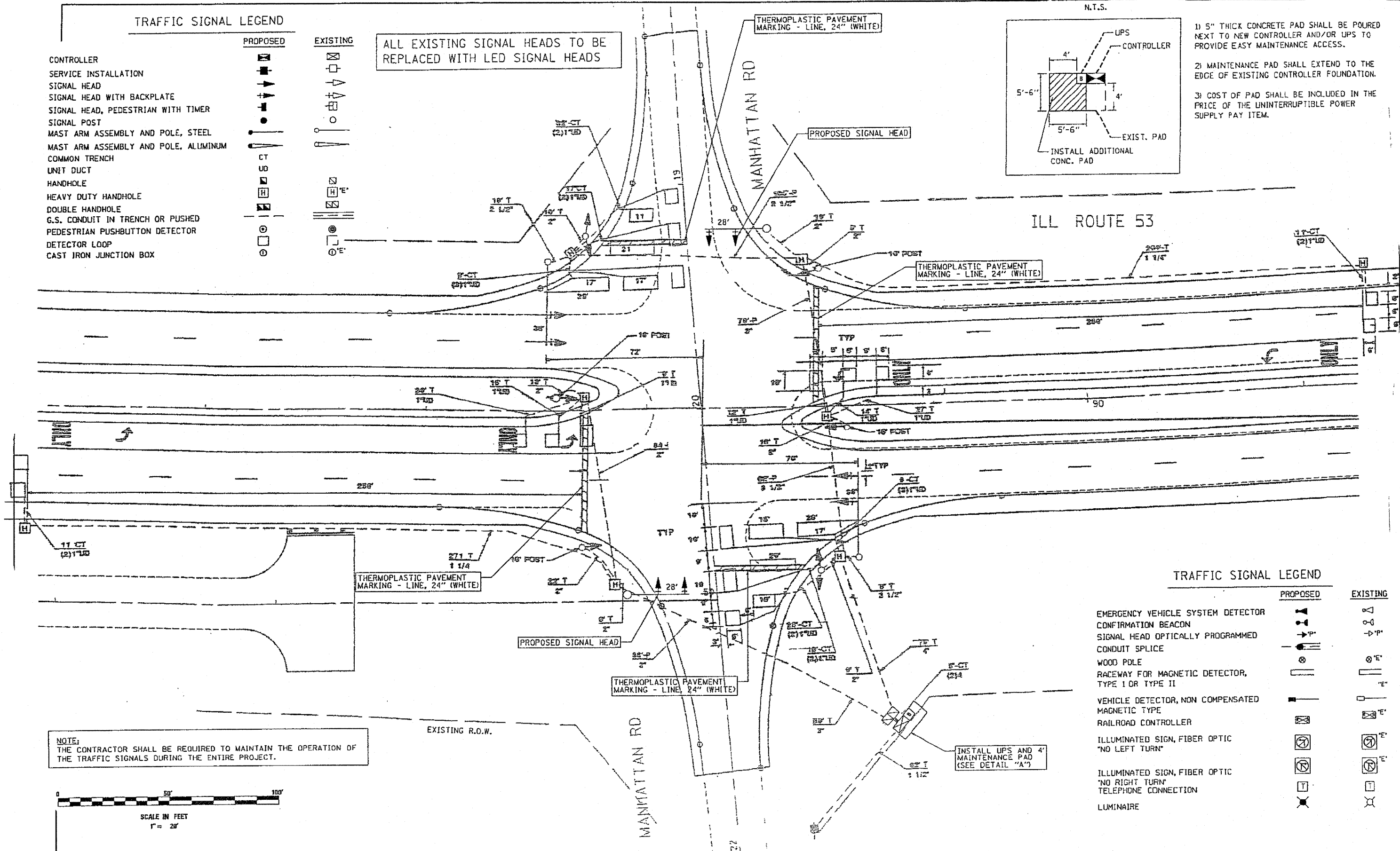

TRAFFIC SIGNAL LEGEND

	PROPOSED	EXISTING
EMERGENCY VEHICLE SYSTEM DETECTOR		
CONFIRMATION BEACON		
SIGNAL HEAD OPTICALLY PROGRAMMED		
CONDUIT SPLICE		
WOOD POLE		
RACEWAY FOR MAGNETIC DETECTOR, TYPE I OR TYPE II		
VEHICLE DETECTOR, NON COMPENSATED MAGNETIC TYPE		
RAILROAD CONTROLLER		
ILLUMINATED SIGN, FIBER OPTIC "NO LEFT TURN"		
ILLUMINATED SIGN, FIBER OPTIC "NO RIGHT TURN"		
TELEPHONE CONNECTION		
LUMINAIRE		

NOTE: THE CONTRACTOR SHALL BE REQUIRED TO MAINTAIN THE OPERATION OF THE TRAFFIC SIGNALS DURING THE ENTIRE PROJECT.

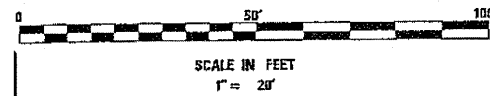

FILE NAME =	USER NAME = qurashiy	DESIGNED -	REVISED -	STATE OF ILLINOIS DEPARTMENT OF TRANSPORTATION	TRAF SIGNAL MODIFICATION PLAN IL 53 AT MANHATTAN RD	F.A.P. RTE.	SECTION	COUNTY	TOTAL SHEETS	SHEET NO.	
c:\pwwork\pwwork\qurashiy\08212316\0124689-shs-plan.dgn	PLOT SCALE = 1/8" = 1' / 31.68"	DRAWN -	REVISED -			846/357	2010-133-1	WILL	54	39	
	PLOT DATE = 10/27/2010	CHECKED -	REVISED -			CONTRACT NO. 60F75					
		DATE -	REVISED -			ILLINOIS FED. AID PROJECT					

CABLE PLAN LEGEND

EXISTING	PROPOSED	DESCRIPTION
		8" (200mm) TRAFFIC SIGNAL SECTION
		12" (300mm) TRAFFIC SIGNAL SECTION
		12" (300mm) PEDESTRIAN SIGNAL SECTION
		12" (300mm) PEDESTRIAN SIGNAL SECTION
		CONTROLLER CABINET
		SERVICE INSTALLATION
		TELEPHONE CONNECTION
		MAGNETIC DETECTOR
		EMERGENCY VEHICLE LIGHT DETECTOR
		CONFIRMATION BEACON
		PUSHBUTTON DETECTOR
		VEHICLE DETECTOR, INDUCTION LOOP
		DENOTES NUMBER OF CONDUCTORS, ALL CABLE NO. 14 EXCEPT AS INDICATED. ALL LOOP DETECTOR CABLE TO BE SHIELDED.
		MICROWAVE VEHICLE SENSOR
		SIGNAL FACE WITH BACKPLATE, "P" INDICATES PROGRAMMED HEAD
		RAILROAD CONTROL CABINET
		ILLUMINATED SIGN, FIBER OPTIC "NO LEFT TURN"
		ILLUMINATED SIGN, FIBER OPTIC "NO RIGHT TURN"
		GROUND ROD AT HANDHOLE (H), DOUBLE HANDHOLE (H), OR CONTROLLER (C).
		GROUND ROD AT POST (P), OR MAST ARM POLE (MA).
		GROUND ROD AT ELECTRIC SERVICE INSTALLATION
		GROUND CABLE IN CONDUIT NO. 6 SOLID COPPER (GREEN)
		FIBER OPTIC CABLE IN CONDUIT NO. 62.5/125 MM12F SM12F
		12" (300mm) PEDESTRIAN SIGNAL SECTION WITH COUNTDOWN TIMER
		UNINTERRUPTIBLE POWER SUPPLY

CONTROLLER SEQUENCE IV
REFERRING TO STANDARD 2393-1, THE VEHICULAR AND PEDESTRIAN PHASES USED ARE DESIGNATED BELOW.

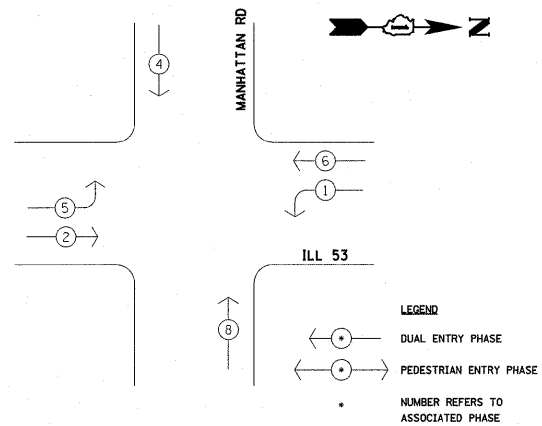

PHASE DESTINATION DIAGRAM

PROPOSED CABLE PLAN

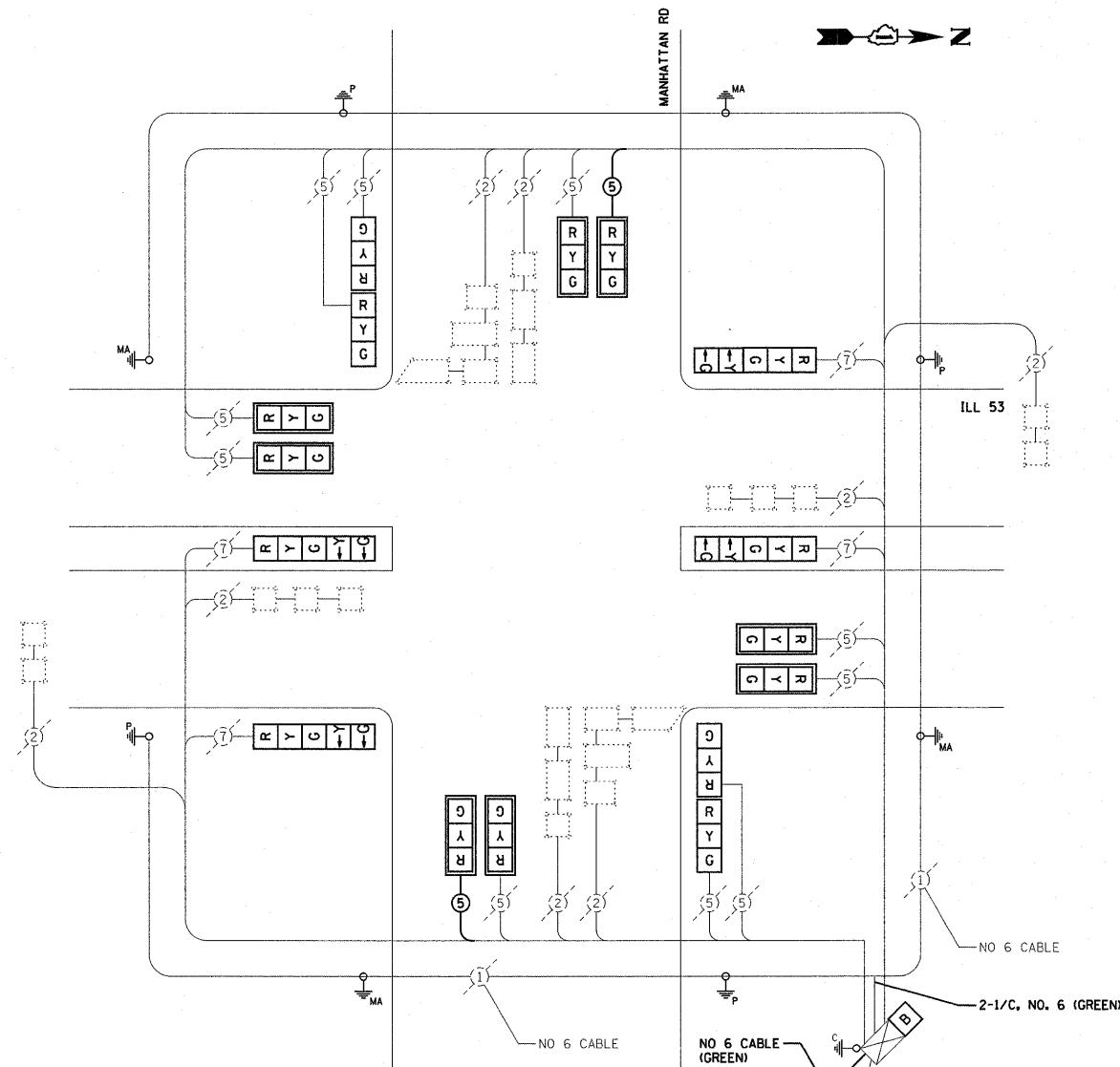

NOTE:
EQUIPMENT GROUND CONDUCTOR (GREEN COLOR CODED) SPLICE TO FRAME AND COVER IS REQUIRED FOR ALL HANDHOLES OR DOUBLE HANDHOLES THAT CARRY SIGNAL CABLES AND SERVICE CABLES.

I.D.O.T. TRAFFIC SIGNAL INSTALLATION ELECTRICAL SERVICE REQUIREMENTS					TOTAL WATTAGE
TYPE	NO. LAMPS	WATTAGE INCAND.	WATTAGE LED	% OPERATION	
SIGNAL (RED)	16	135	17	0.50	136.00
(YELLOW)	16	135	25	0.25	100.00
(GREEN)	16	135	15	0.25	60.00
ARROW	8	135	12	0.10	9.60
PED. SIGNAL	0	90	25	1.00	0.00
CONTROLLER	1	100	100	1.00	100.00

ENERGY COSTS TO: TOTAL = 405.60
ILLINOIS DEPARTMENT OF TRANSPORTATION
201 WEST CENTER COURT
SCHAUMBURG, ILLINOIS 60196-1096
ENERGY SUPPLY CONTACT: _____
PHONE: _____
COMPANY: COM. ED.

FOUNDATION (DEPTH)	FT. (m)	CABLE SLACK	FT. (m)	FT. (m)
TYPE A - POST	4 (1.2)	HANDHOLE	6.5 (2.0)	ALL FOUNDATIONS
D - CONTROLLER	4 (1.2)	DOUBLE HANDHOLE	13 (4.0)	MAST ARM (L) POLE
E - M. ARM POLE	2 (0.6)	SIGNAL POST	2 (0.6)	20'-H-2"
24" (600mm)	10 (3.0)	CONTROLLER CAB.	1 (0.5)	BRACKET MOUNTED
30" (750mm)	15 (4.6)	FIBER OPTIC	13 (4.0)	PED. PUSHBUTTON
		ELECTRIC SERVICE	1 (0.5)	ELECTRIC SERVICE
		GROUND CABLE	1 (0.5)	SERVICE TO GROUND
				POST MOUNTED

CODE #	DESCRIPTION	UNIT	QUANTITY
78000650	THERMOPLASTIC PAVEMENT MARKING - LINE 24"	FOOT	165
78300400	THERMOPLASTIC PAVEMENT MARKING REMOVAL	SO FT	325
85000200	MAINTENANCE OF EXISTING TRAFFIC SIGNAL INSTALLATION	EACH	1
87301245	ELECTRIC CABLE IN CONDUIT, SIGNAL NO. 14 5C	FOOT	550
87301805	ELECTRIC CABLE IN CONDUIT, SERVICE, NO. 6 2 C	FOOT	100
88030020	SIGNAL HEAD, LED, 1-FACE, 3-SECTION, MAST-ARM MOUNTED	EACH	8
88030100	SIGNAL HEAD, LED, 1-FACE, 5-SECTION, BRACKET MOUNTED	EACH	4
88030210	SIGNAL HEAD, LED, 2-FACE, 3-SECTION, BRACKET MOUNTED	EACH	2
88200210	TRAFFIC SIGNAL BACKPLATE, LOUVERED, ALUMINUM	EACH	8
89502375	REMOVE EXISTING TRAFFIC SIGNAL EQUIPMENT	EACH	1
X8050015	SERVICE INSTALLATION - POLE MOUNTED	EACH	1
X8620020	UNINTERRUPTIBLE POWER SUPPLY	EACH	1
X8730027	ELECTRIC CABLE IN CONDUIT, GROUNDING, NO. 6 1C	FOOT	100

EXISTING EQUIPMENT TO BE REMOVED LEGEND

- EXISTING CONTROLLER TO BE REMOVED
- EXISTING SERVICE INSTALLATION TO BE REMOVED
- EXISTING SIGNAL HEAD TO BE REMOVED
- EXISTING SIGNAL HEAD WITH BACKPLATE TO BE REMOVED
- EXISTING PEDESTRIAN SIGNAL HEAD TO BE REMOVED
- EXISTING SIGNAL POST TO BE REMOVED
- EXISTING STEEL MAST ARM POLE AND FOUNDATION TO BE REMOVED
- EXISTING ALUMINUM MAST ARM POLE AND FOUNDATION TO BE REMOVED
- EXISTING HANDHOLE TO BE REMOVED
- EXISTING HEAVY DUTY HANDHOLE TO BE REMOVED
- EXISTING PEDESTRIAN PUSHBUTTON TO BE REMOVED
- EXISTING EMERGENCY VEHICLE SYSTEM DETECTOR TO BE REMOVED
- EXISTING CONFIRMATION BEACON TO BE REMOVED

ALL EXISTING SIGNAL HEADS TO BE REPLACED WITH LED SIGNAL HEADS

THE FOLLOWING ITEMS SHALL BE REMOVED BY THE CONTRACTOR AND SHALL BE DISPOSED OF BY THEM OUTSIDE THE RIGHT-OF-WAY AT THEIR EXPENSE. THE SALVAGE VALUE OF THE REMOVED EQUIPMENT SHALL BE REFLECTED IN THE CONTRACT BID PRICE.

- 4 EACH SIGNAL HEAD, 1-FACE, 3-SECTION BRACKET MOUNTED
- 2 EACH SIGNAL HEAD, 1-FACE, 3-SECTION MAST ARM MOUNTED
- 2 EACH SIGNAL HEAD, 1-FACE, 5-SECTION MAST ARM MOUNTED
- 2 EACH SIGNAL HEAD, 2-FACE, 1-3 SECTION, 1-5 SECTION BRACKET MOUNTED
- 2 EACH TRAFFIC SIGNAL POST
- 2 EACH CONCRETE FOUNDATION
- 4 EACH TRAFFIC SIGNAL BACKPLATE

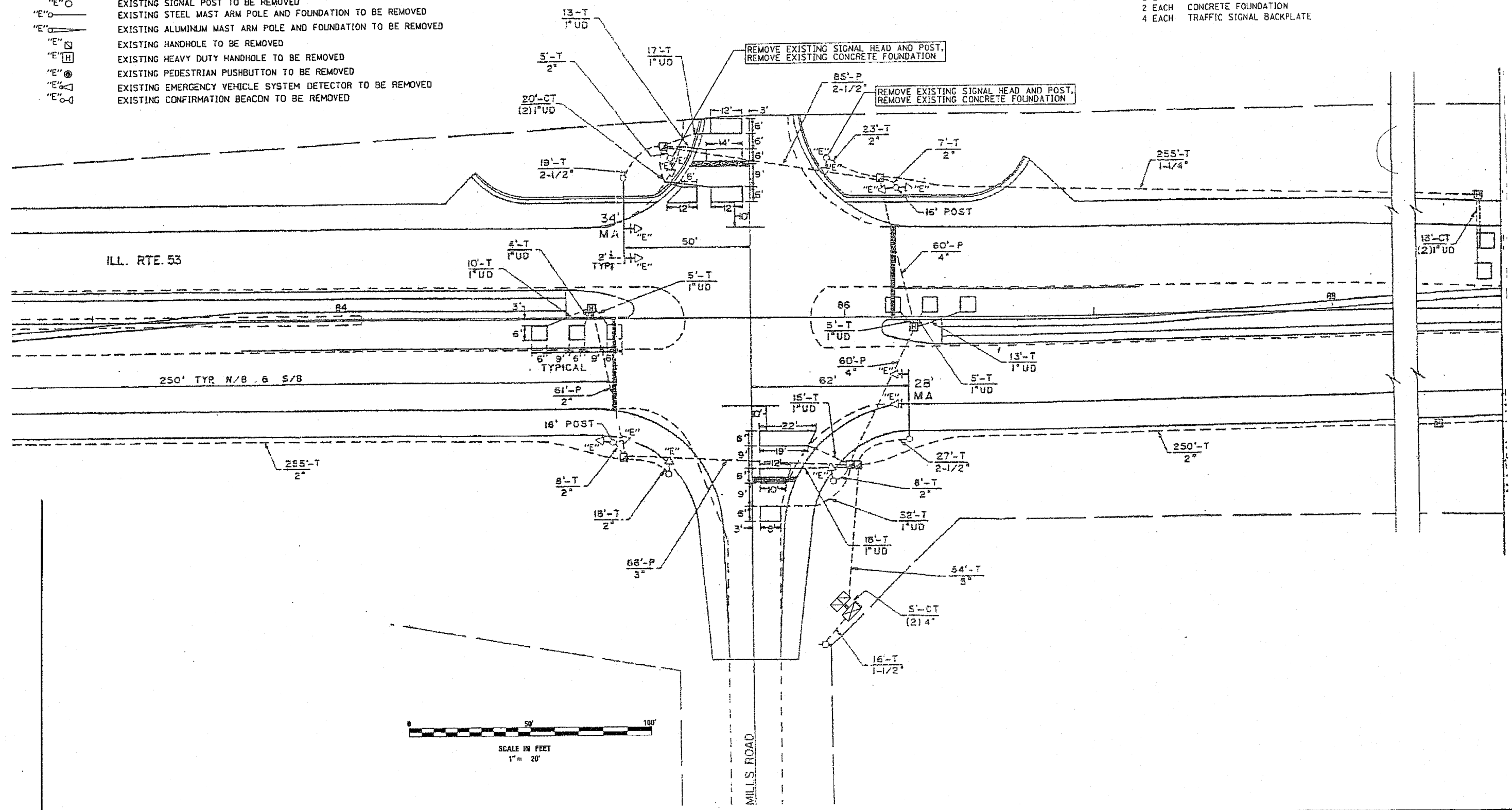

FILE NAME =	USER NAME = gureshigo	DESIGNED -	REVISED -	STATE OF ILLINOIS DEPARTMENT OF TRANSPORTATION	TRAFFIC SIGNAL REMOVAL PLAN IL 53 AT MILLS RD	F.A.P. RTE.	SECTION	COUNTY	TOTAL SHEETS	SHEET NO.	
en:\pwork\psudot\gureshigo\d0212318\012	689-ght-pln.dgn	DRAWN -	REVISED -			846/357	2010-133-1	WILL	54	41	
PLOT SCALE = 1/8" = 1' IN.	CHECKED -	REVISED -	SCALE: NTS			SHEET NO. 1 OF 3 SHEETS	STA.	TO STA.	CONTRACT NO. 60F75		
PLOT DATE = 10/27/2010	DATE -	REVISED -	ILLINOIS FED. AID PROJECT								

DETAIL A
N.T.S.

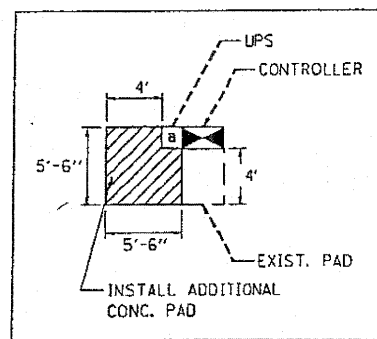

- 1) 5" THICK CONCRETE PAD SHALL BE POURED NEXT TO NEW CONTROLLER AND/OR UPS TO PROVIDE EASY MAINTENANCE ACCESS.
- 2) MAINTENANCE PAD SHALL EXTEND TO THE EDGE OF EXISTING CONTROLLER FOUNDATION.
- 3) COST OF PAD SHALL BE INCLUDED IN THE PRICE OF THE UNINTERRUPTIBLE POWER SUPPLY PAY ITEM.

NOTE:
THE CONTRACTOR SHALL BE REQUIRED TO MAINTAIN THE OPERATION OF THE TRAFFIC SIGNALS DURING THE ENTIRE PROJECT.

NOTE:
THE FINAL LOCATION OF THE WESTBOUND MAST ARM WILL BE DETERMINED IN THE FIELD AND THE CONTRACTOR SHALL VERIFY THE LOCATION WITH THE RESIDENT ENGINEER.

NOTE:
THE TRAFFIC SIGNAL CONTROL EQUIPMENT FOR THIS PROJECT SHALL BE "ECONOLITE" TO MATCH THE EXISTING ADJACENT SYSTEM.

ALL EXISTING SIGNAL HEADS TO BE REPLACED WITH LED SIGNAL HEADS

PROPOSED 48' MAST ARM ASSEMBLY WITH 2 SIGNAL HEADS AND CONCRETE FOUNDATION

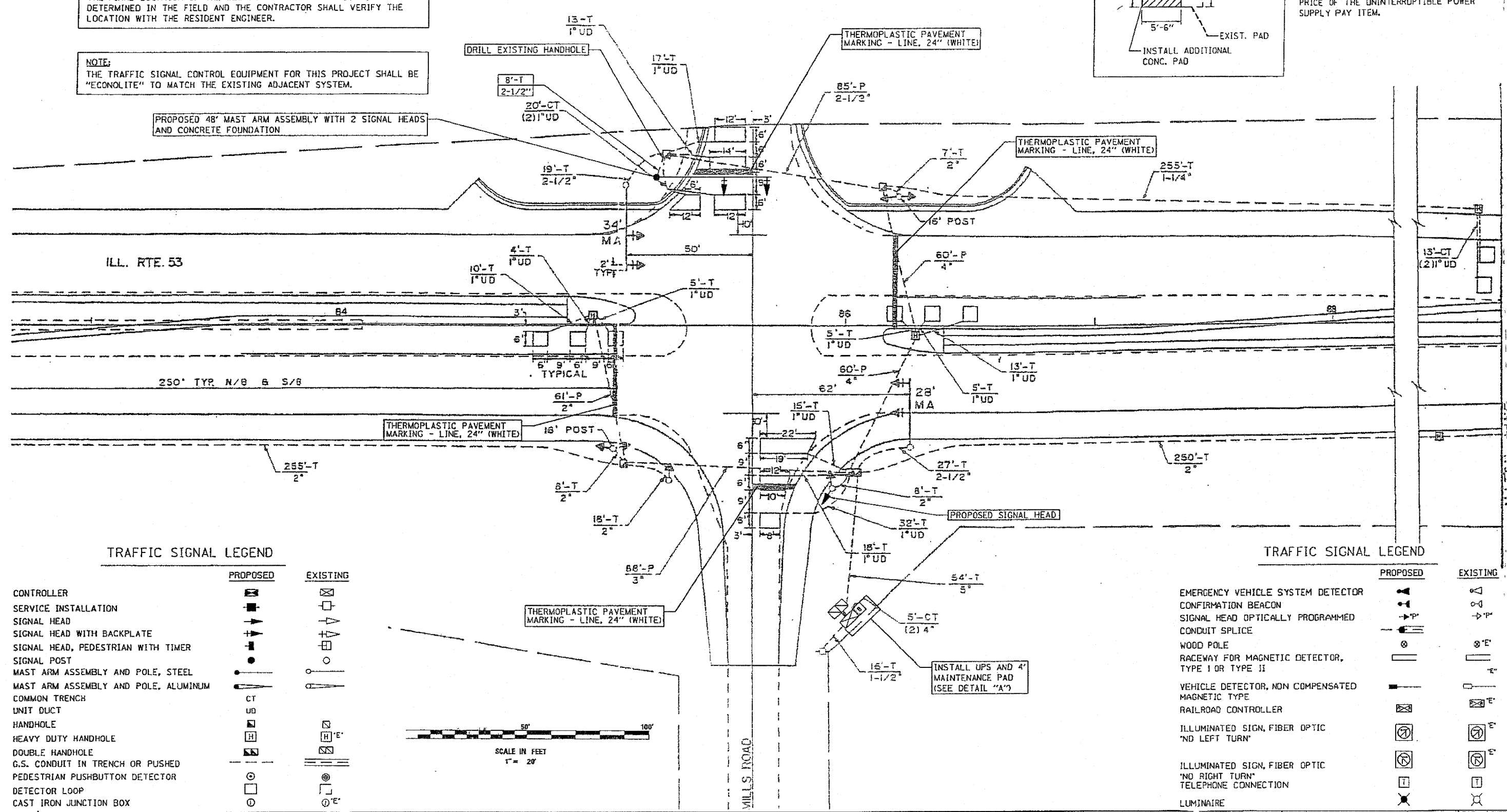

TRAFFIC SIGNAL LEGEND

	PROPOSED	EXISTING
CONTROLLER		
SERVICE INSTALLATION		
SIGNAL HEAD		
SIGNAL HEAD WITH BACKPLATE		
SIGNAL HEAD, PEDESTRIAN WITH TIMER		
SIGNAL POST		
MAST ARM ASSEMBLY AND POLE, STEEL		
MAST ARM ASSEMBLY AND POLE, ALUMINUM		
COMMON TRENCH		
UNIT DUCT		
HANDHOLE		
HEAVY DUTY HANDHOLE		
DOUBLE HANDHOLE		
G.S. CONDUIT IN TRENCH OR PUSHED		
PEDESTRIAN PUSHBUTTON DETECTOR		
DETECTOR LOOP		
CAST IRON JUNCTION BOX		

TRAFFIC SIGNAL LEGEND

	PROPOSED	EXISTING
EMERGENCY VEHICLE SYSTEM DETECTOR		
CONFIRMATION BEACON		
SIGNAL HEAD OPTICALLY PROGRAMMED		
CONDUIT SPLICE		
WOOD POLE		
RACEWAY FOR MAGNETIC DETECTOR, TYPE I OR TYPE II		
VEHICLE DETECTOR, NON COMPENSATED MAGNETIC TYPE		
RAILROAD CONTROLLER		
ILLUMINATED SIGN, FIBER OPTIC 'NO LEFT TURN'		
ILLUMINATED SIGN, FIBER OPTIC 'NO RIGHT TURN'		
TELEPHONE CONNECTION		
LUMINAIRE		

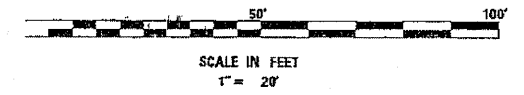

FILE NAME =	USER NAME = qurashige	DESIGNED -	REVISED -	STATE OF ILLINOIS DEPARTMENT OF TRANSPORTATION	TRAF SIGNAL MODIFICATION PLAN IL 53 AT MILLS RD	F.A.P. RTE.	SECTION	COUNTY	TOTAL SHEETS	SHEET NO.
		DRAWN -	REVISED -			• 2010-133-1	WILL	54	42	
		CHECKED -	REVISED -			• 846/357	CONTRACT NO. 60F75			
		DATE -	REVISED -			ILLINOIS FED. AID PROJECT				

CABLE PLAN LEGEND

EXISTING	PROPOSED	DESCRIPTION
[G]	[G]	8" (200mm) TRAFFIC SIGNAL SECTION
[R]	[R]	12" (300mm) TRAFFIC SIGNAL SECTION
[W]	[W]	12" (300mm) PEDESTRIAN SIGNAL SECTION
[W]	[W]	12" (300mm) PEDESTRIAN SIGNAL SECTION
[C]	[C]	CONTROLLER CABINET
[S]	[S]	SERVICE INSTALLATION
[T]	[T]	TELEPHONE CONNECTION
[M]	[M]	MAGNETIC DETECTOR
[E]	[E]	EMERGENCY VEHICLE LIGHT DETECTOR
[C]	[C]	CONFIRMATION BEACON
[P]	[P]	PUSHBUTTON DETECTOR
[V]	[V]	VEHICLE DETECTOR, INDUCTION LOOP
[2]	[2]	DENOTES NUMBER OF CONDUCTORS, ALL CABLE NO. 14 EXCEPT AS INDICATED. ALL LOOP DETECTOR CABLE TO BE SHIELDED.
[M]	[M]	MICROWAVE VEHICLE SENSOR
[R]	[R]	SIGNAL FACE WITH BACKPLATE, "P" INDICATES PROGRAMMED HEAD
[R]	[R]	RAILROAD CONTROL CABINET
[I]	[I]	ILLUMINATED SIGN, FIBER OPTIC "NO LEFT TURN"
[I]	[I]	ILLUMINATED SIGN, FIBER OPTIC "NO RIGHT TURN"
[H]	[H]	GROUND ROD AT HANDHOLE (H), DOUBLE HANDHOLE (H), OR CONTROLLER (C).
[P]	[P]	GROUND ROD AT POST (P), OR MAST ARM POLE (MA).
[S]	[S]	GROUND ROD AT ELECTRIC SERVICE INSTALLATION
[1]	[1]	GROUND CABLE IN CONDUIT NO. 6 SOLID COPPER (GREEN)
[2]	[2]	FIBER OPTIC CABLE IN CONDUIT NO. 62.5/125 MM12F SM12F
[P]	[P]	12" (300mm) PEDESTRIAN SIGNAL SECTION WITH COUNTDOWN TIMER
[B]	[B]	UNINTERRUPTIBLE POWER SUPPLY

CONTROLLER SEQUENCE IV
 REFERRING TO STANDARD 2393-1, THE VEHICULAR AND PEDESTRIAN PHASES USED ARE DESIGNATED BELOW.

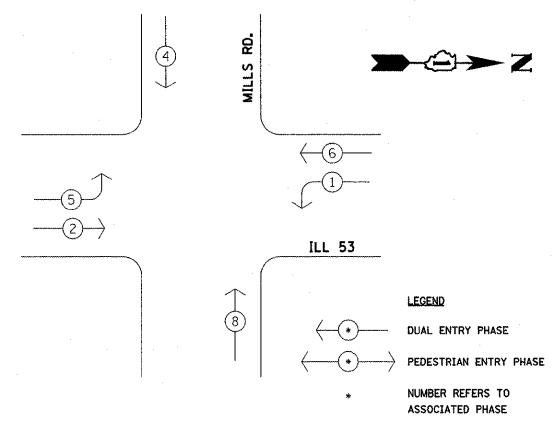

PHASE DESTINATION DIAGRAM

PROPOSED CABLE PLAN

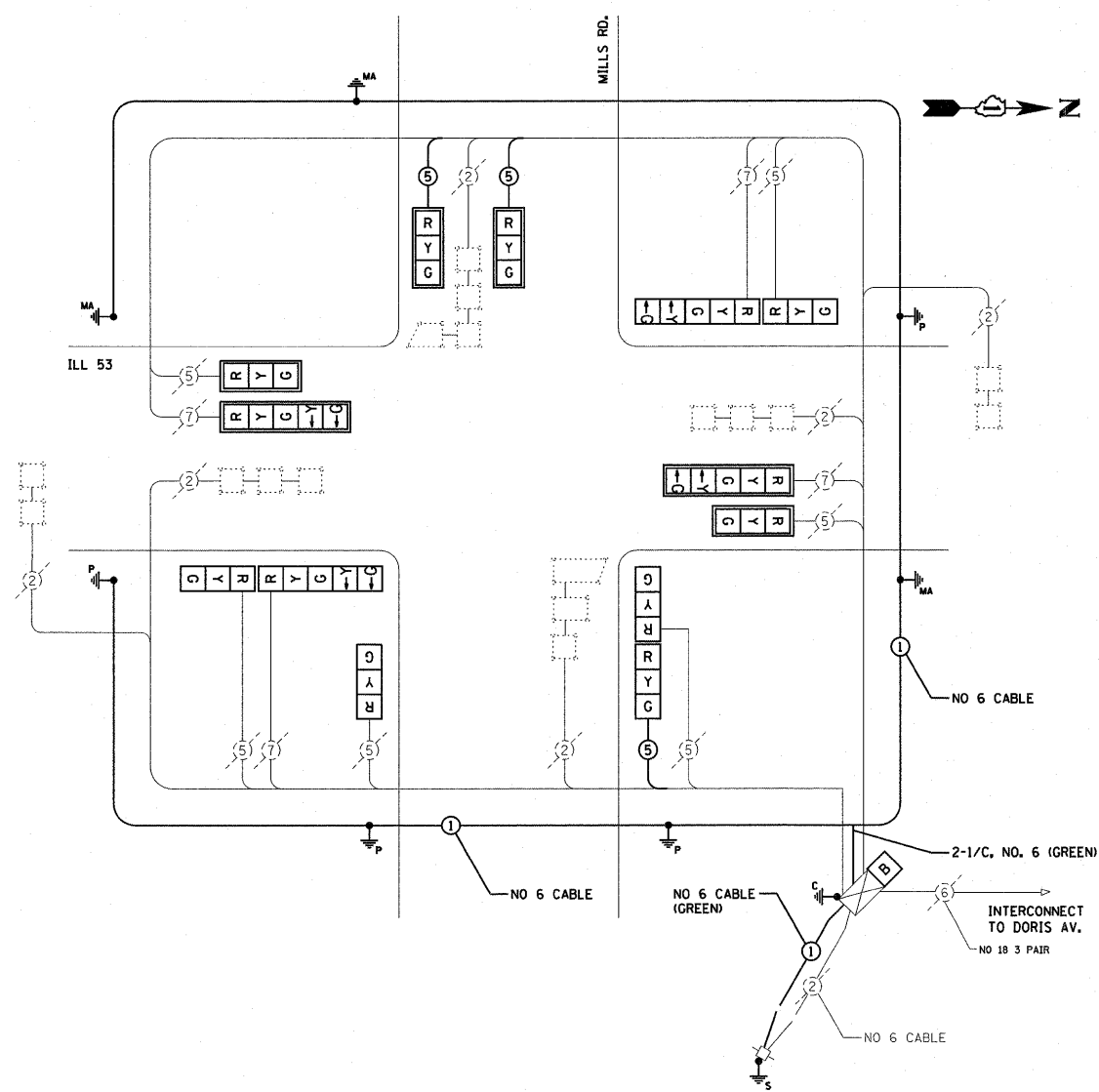

NOTE:
 EQUIPMENT GROUND CONDUCTOR (GREEN COLOR CODED) SPLICE TO FRAME AND COVER IS REQUIRED FOR ALL HANDHOLES OR DOUBLE HANDHOLES THAT CARRY SIGNAL CABLES AND SERVICE CABLES.

I.D.O.T TRAFFIC SIGNAL INSTALLATION ELECTRICAL SERVICE REQUIREMENTS					TOTAL WATTAGE
TYPE	NO. LAMPS	WATTAGE INCAND.	WATTAGE LED	% OPERATION	
SIGNAL (RED)	13	135	17	0.50	110.50
(YELLOW)	13	135	25	0.25	81.25
(GREEN)	13	135	15	0.25	48.75
ARROW	8	135	12	0.10	9.60
PED. SIGNAL	0	90	25	1.00	0.00
CONTROLLER	1	100	100	1.00	100.00

ENERGY COSTS TO: TOTAL = 350.10
 ILLINOIS DEPARTMENT OF TRANSPORTATION
 201 WEST CENTER COURT
 SCHAUMBURG, ILLINOIS 60196-1096
 ENERGY SUPPLY CONTACT: _____
 PHONE: _____
 COMPANY: COM. ED.

FOUNDATION (DEPTH)	FT. (m)	CABLE SLACK	FT. (m)	FT. (m)
TYPE A - POST	4 (1.2)	HANDHOLE	6.5 (2.0)	ALL FOUNDATIONS
D - CONTROLLER	4 (1.2)	DOUBLE HANDHOLE	13 (4.0)	MAST ARM (L) POLE
E - M. ARM POLE	2 (0.6)	SIGNAL POST	2 (0.6)	20'+H-2' (6m+H-0.6m)
24" (600mm)	10 (3.0)	CONTROLLER CAB.	1 (0.5)	BRACKET MOUNTED
30" (750mm)	15 (4.6)	FIBER OPTIC	13 (4.0)	PED. PUSHBUTTON
		ELECTRIC SERVICE	1 (0.5)	ELECTRIC SERVICE
		GROUND CABLE	1 (0.5)	SERVICE TO GROUND
				POST MOUNTED

CODE #	DESCRIPTION	UNIT	QUANTITY
78000650	THERMOPLASTIC PAVEMENT MARKING - LINE 24"	FOOT	100
78300400	THERMOPLASTIC PAVEMENT MARKING REMOVAL	50 FT	200
81000700	CONDUIT IN TRENCH, 2 1/2" DIA., GALVANIZED STEEL	FOOT	10
81900200	TRENCH AND BACKFILL FOR ELECTRICAL WORK	FOOT	10
85000200	MAINTENANCE OF EXISTING TRAFFIC SIGNAL INSTALLATION	EACH	1
87301245	ELECTRIC CABLE IN CONDUIT, SIGNAL NO. 14 5C	FOOT	900
87700280	STEEL MAST ARM ASSEMBLY AND POLE, 48 FT.	EACH	1
87800415	CONCRETE FOUNDATION, TYPE E 36-INCH DIAMETER	FOOT	13
87900200	DRILL EXISTING HANDHOLE	EACH	1
88030020	SIGNAL HEAD, LED, 1-FACE, 3-SECTION, MAST-ARM MOUNTED	EACH	4
88030050	SIGNAL HEAD, LED, 1-FACE, 3-SECTION, BRACKET MOUNTED	EACH	1

CODE #	DESCRIPTION	UNIT	QUANTITY
88030110	SIGNAL HEAD, LED, 1-FACE, 5-SECTION, MAST-ARM MOUNTED	EACH	5
88030210	SIGNAL HEAD, LED, 2-FACE, 3-SECTION, BRACKET MOUNTED	EACH	1
88030240	SIGNAL HEAD, LED, 2-FACE, 1-3 SECTION, 1-5 SECTION, BRACKET MOUNTED	EACH	2
88200210	TRAFFIC SIGNAL BACKPLATE, LOUVERED, ALUMINUM	EACH	6
89502300	REMOVE ELECTRIC CABLE FROM CONDUIT	FOOT	600
89502375	REMOVE EXISTING TRAFFIC SIGNAL EQUIPMENT	EACH	1
89502385	REMOVE EXISTING CONCRETE FOUNDATION	EACH	2
X8140074	GROUNDING EXISTING HANDHOLE FRAME AND COVER	EACH	7
X8620020	UNINTERRUPTIBLE POWER SUPPLY	EACH	1
X8730027	ELECTRIC CABLE IN CONDUIT, GROUNDING, NO. 6 1C	FOOT	750

STATE OF ILLINOIS DEPARTMENT OF TRANSPORTATION

CABLE PLAN, PHASE DESIGNATION DIAGRAM, SCHEDULE OF QUANTITIES, IL 53 AT MILLS ROAD

FILE NAME = ... USER NAME = qureshiye ... DESIGNED - ... REVISED - ...
 DRAWN - ... REVISED - ...
 CHECKED - ... REVISED - ...
 DATE - ... REVISED - ...

F.A.P. RTE.	SECTION	COUNTY	TOTAL SHEETS	SHEET NO.
•	2010-133-1	WILL	54	43
•	846/357		CONTRACT NO. 60F75	
			ILLINOIS FED. AID PROJECT	

SCALE: NTS SHEET NO. 3 OF 3 SHEETS STA. TO STA.

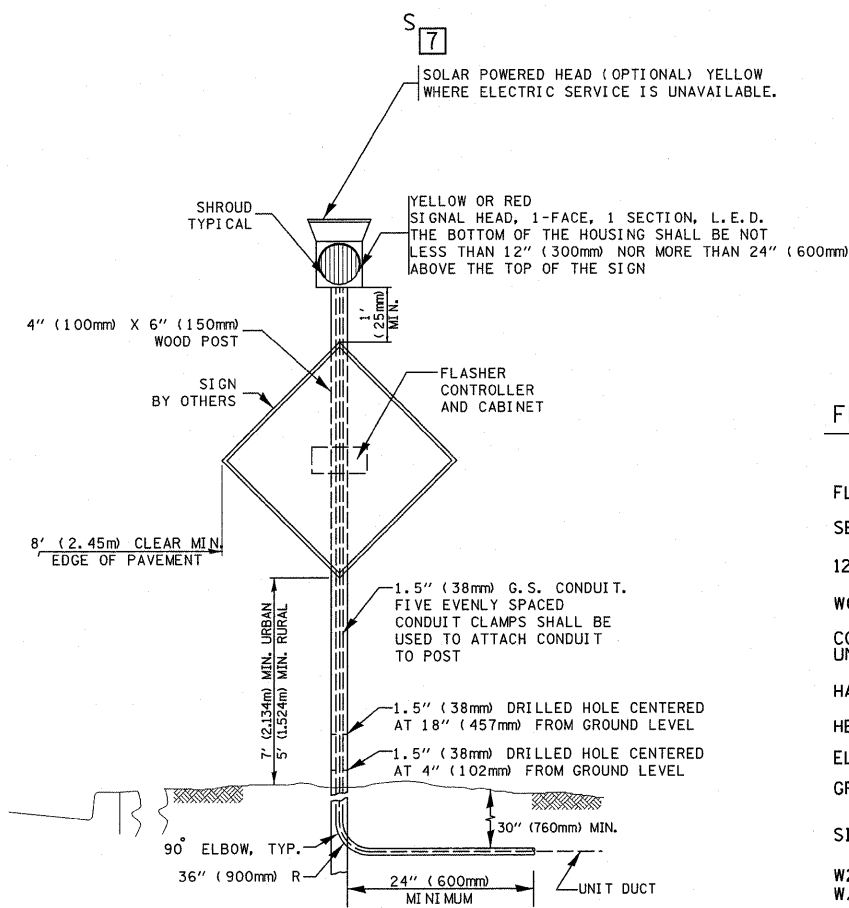

YELLOW - POST MOUNTED FLASHER DETAIL (TYPICAL)

FLASHER SIGNAL LEGEND

	PROPOSED	EXISTING
FLASHER CONTROL CABINET	[Symbol]	[Symbol]
SERVICE INSTALLATION	[Symbol]	[Symbol]
12" SIGNAL HEAD (LED)	[Symbol]	[Symbol]
WOOD POST, 4" x 6"	[Symbol]	[Symbol] "E"
CONDUIT IN GROUND OR UNIT DUCT IN TRENCH	[Symbol]	[Symbol]
HANDHOLE	[Symbol]	[Symbol]
HEAVY-DUTY HANDHOLE	[Symbol]	[Symbol] "E"
ELECTRICAL POLE	[Symbol]	[Symbol]
GROUND ROD	[Symbol]	[Symbol]
SIGNAL FACE WITH BACKPLATE	[Symbol]	[Symbol]
W2-1 OR W2-2 WARNING SIGN W/ STREET PANEL	[Symbol]	[Symbol]
JUNCTION BOX - STAINLESS STEEL	[Symbol]	[Symbol]

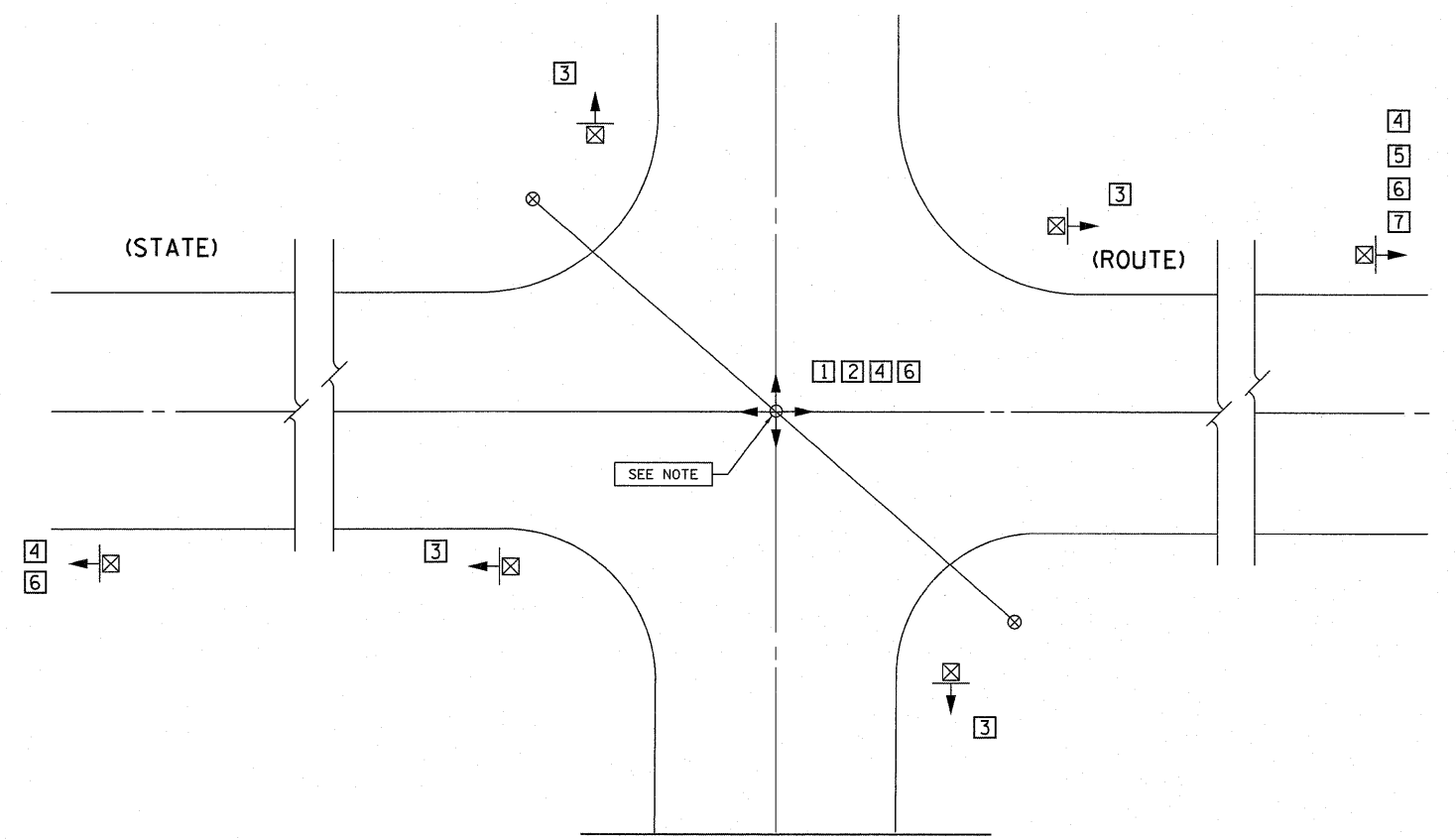

VARIOUS PLANS - TRAFFIC SIGNAL FLASHERS N.T.S.

- 1 U.S. ROUTE 45/52 @ WILMINGTON/ PEOTONE RD. (VILLAGE OF PEOTONE)
- 2 GOVERNORS HWY. @ STUENKEL RD. (VILLAGE OF UNIVERSITY PARK)
- 3 U.S. ROUTE 52 @ LARAWAY RD. (CITY OF JOLIET)
- 4 U.S. ROUTE 6 @ PARKER RD. (VILLAGE OF MOKENA)
- 5 U.S. ROUTE 6 @ BRANDON RD. (CITY OF JOLIET)
- 6 IL. ROUTE 129 @ STRIP MINE RD. (CITY OF WILMINGTON)
- 7 IL. ROUTE 126 @ ESSINGTON RD. (CITY OF PLAINFIELD)

NOTES:

REMOVAL OF INCANDESCENT OPTICS ARE INCLUDED IN L.E.D. RETROFIT PAY ITEM

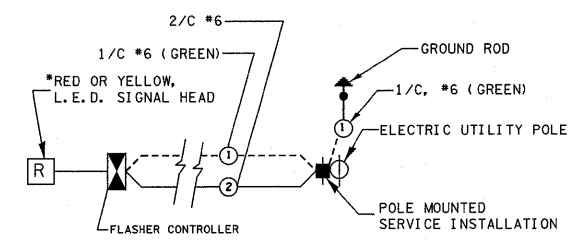

TYPICAL CABLE PLAN

- YELLOW FLASHER - MOUNTED IN ADVANCE OF INTERSECTION
- RED FLASHER - MOUNTED AT INTERSECTION

SCHEDULE OF QUANTITIES

ITEM	UNIT	QUANTITY
SIGNAL HEAD, L.E.D. 1-SECTION, POST MOUNTED, RETROFIT	EACH	1

	1	2	3	4	5	6	7
ITEM DESCRIPTION	U.S. RTE. 45/52 @ WILMINGTON PEOTONE RD.	GOVERNOR'S HWY @ STUENKEL ROAD	U.S. RTE. 52 @ LARAWAY ROAD	U.S. RTE. 6 @ PARKER ROAD	U.S. RTE. 6 @ BRANDON ROAD	IL. RTE. 129 @ STRIP MINE RD.	IL. RTE. 126 @ ESSINGTON RD.
TRAFFIC SIGNAL FLASHER 1-SECTION, L.E.D.- (RED)	4	4	4	4		4	
TRAFFIC SIGNAL FLASHER 1-SECTION, L.E.D.- (YELLOW)				2	* 1	2	S ₁

- * ADVANCED WARNING FLASHER WESTBOUND U.S. ROUTE 6
- △ ADVANCED WARNING FLASHER(S) NORTH & SOUTHBOUND IL. ROUTE 129 @ STRIP MINE RD.
- ADVANCED WARNING FLASHER(S) EAST & WESTBOUND U.S. ROUTE 6 @ PARKER RD.
- S ADVANCED WARNING FLASHER WESTBOUND (SOLAR POWERED) ON IL. ROUTE 126
- [Hatched] NOT APPLICABLE THIS LOCATION

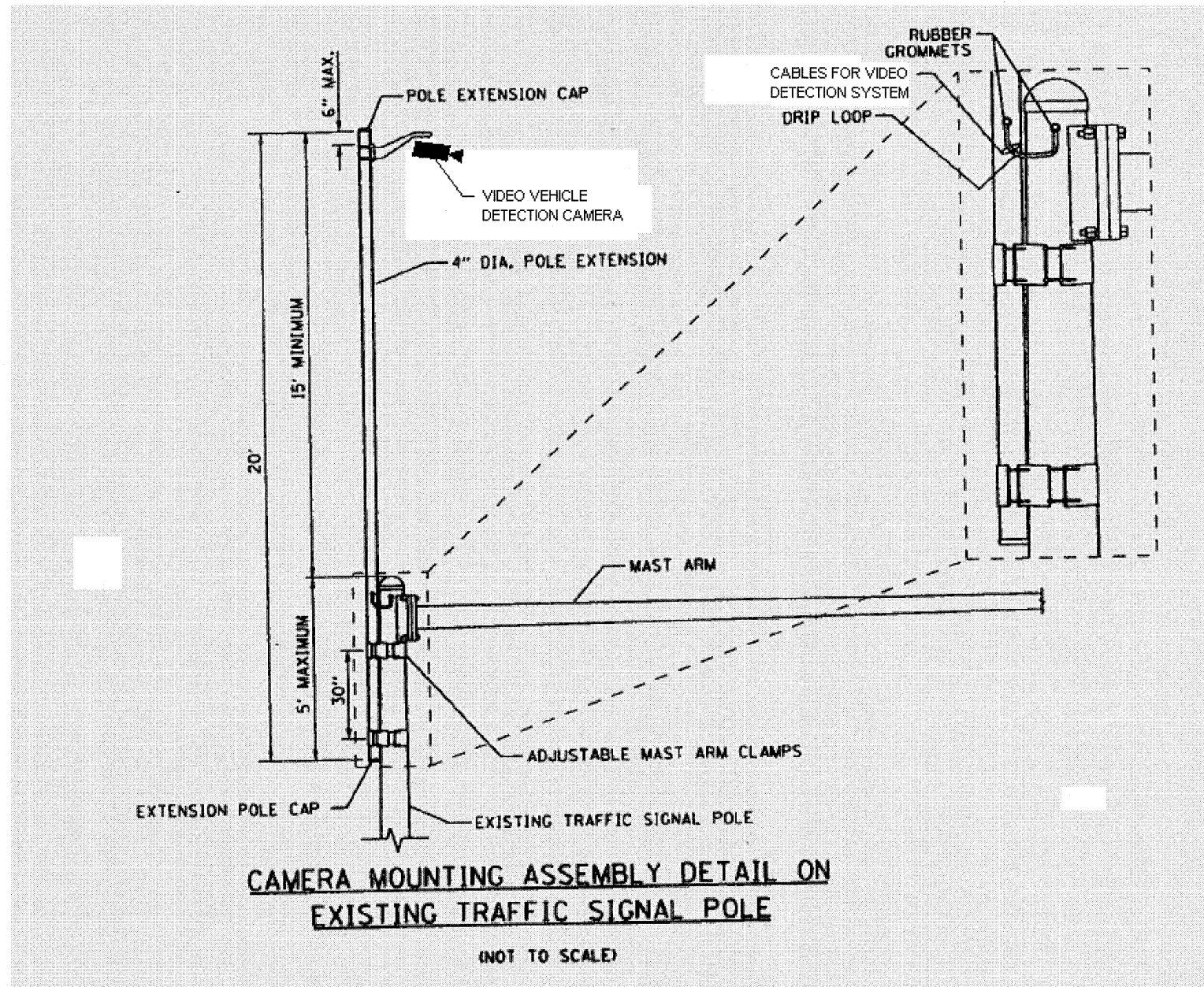

NOTE:
 1) THIS WORK IS INCLUDED IN THE COST FOR VIDEO DETECTION SYSTEM.
 2) THE CONTRACTOR SHALL ADJUST THE CAMERA TO OBTAIN A 6' X 18' DETECTION AREA AT THE LOCATION SHOWN ON THE PLANS.

FILE NAME =	USER NAME = qureshiya	DESIGNED -	REVISED -
c:\pw_work\pw\dot\qureshiya\d0212316\0123609-sht-pln.dgn		DRAWN -	REVISED -
PLOT SCALE = 50.0000' / IN.		CHECKED -	REVISED -
PLOT DATE = 10/26/2010		DATE -	REVISED -

**STATE OF ILLINOIS
DEPARTMENT OF TRANSPORTATION**

**TRAFFIC SIGNAL DETAIL
VIDEO DETECTION SYSTEM**

SCALE: NTS SHEET NO. 1 OF 1 SHEETS STA. TO STA.

F.A.P. RTE.	SECTION	COUNTY	TOTAL SHEETS	SHEET NO.
• 846/357	2010-133-1	WILL	54	45
			CONTRACT NO. 60F75	
ILLINOIS FED. AID PROJECT				

LOOP DETECTOR NOTES

1. EACH PAIR OF LOOP WIRES SHALL BE PLACED IN A SEPARATE EMPTY COILABLE NONMETALLIC CONDUIT FROM THE EDGE OF PAVEMENT TO THE HANDHOLE. SPACING BETWEEN THE HOLES DRILLED IN THE PAVEMENT SHALL NOT BE LESS THAN 6" (150 mm). EMPTY COILABLE NONMETALLIC CONDUIT SHALL BE INCLUDED IN THE COST OF THE LOOP WIRE.
2. THE NUMBER OF LOOP TURNS SHALL BE AS RECOMMENDED BY THE AMPLIFIER MANUFACTURER. ALL ADJACENT SIDES OF THE LOOPS SHALL BE INSTALLED IN SUCH A WAY THAT THE CURRENT FLOW IS IN THE SAME DIRECTION TO REINFORCE ITS MAGNETIC FIELDS FOR SMALL VEHICLE DETECTION.
3. EACH LOOP LEAD-IN SHALL BE IDENTIFIED AND PERMANENTLY TAGGED IN THE HANDHOLE. EACH LEAD-IN CABLE TAG SHALL INDICATE THE LOCATION OF THE LOOP, LOOP ROTATION (CLOCKWISE/COUNTERCLOCKWISE), LOOP LEAD-IN DIRECTION (IN OR OUT), LOOP CABLE NUMBER AND LOCATION IN CABINET, AND NUMBER OF TURNS IN THE DETECTOR LOOPS IN WATER PROOF INK AS INDICATED ON THE DISTRICT 1 STANDARD TRAFFIC SIGNAL DESIGN DETAIL. THE CONTRACTOR SHALL MARK LOOP LOCATIONS ON RECORD DRAWINGS AND PRESENT TO THE ENGINEER AFTER FINAL INSPECTION. LOOPS SHALL BE MARKED BY LANE AND LOOP NUMBER. SEE DETAIL BELOW.
4. ALL LOOP CABLE SHALL BE FASTENED WITH PLASTIC TIE WRAP TO THE HANDHOLE HOOKS.
5. IN ASPHALT PAVEMENT, LOOPS SHOULD BE PLACED IN THE BINDER AND DIVEHOLES MARKED AT THE CURB WITH A SAW-CUT. THE SAW-CUT SHALL BE CUT IN ACCORDANCE WITH LOCAL AND E.P.A. DUST CONTROL REQUIREMENTS. DETECTOR LOOP(S) SHALL NOT BE INSTALLED IN WET CONDITIONS AND THE SAW-CUTS MUST BE FREE OF DEBRIS AND RESIDUE SUCH AS DUST AND WATER WHICH IS TO BE ACHIEVED BY THE USE OF COMPRESSED AIR, WIRE BRUSHING AND HEAT DRYING ACCORDING TO SEALANT MANUFACTURER REQUIREMENTS. THE DETECTOR WIRE SHALL BE HELD IN PLACE BY THE USE OF FORM WEDGES. WEDGES SHALL BE SPACED NO MORE THAN 18" (450 mm) APART.
6. LOOP SPLICES SHALL BE SOLDERED USING A SOLDERING IRON. BLOW TORCHES OR OTHER DEVICES WHICH OXIDIZE COPPER CABLE SHALL NOT BE ALLOWED FOR SOLDERING OPERATIONS. SEE DETAIL BELOW RIGHT.
7. PREFORMED DETECTOR LOOPS SHALL BE USED, AS SHOWN ON THE PLANS, WHERE NEW CONCRETE PAVEMENT IS PROPOSED. THE INSTALLATION OF PREFORMED LOOPS SHALL BE IN ACCORDANCE WITH THE DISTRICT 1 SPECIFICATIONS OR AS DIRECTED BY THE ENGINEER.

LOOP LEAD-IN CABLE TAG

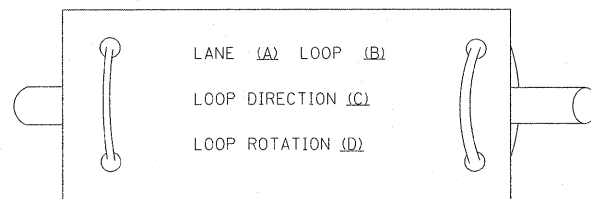

- A. LANE 1 IS THE LANE CLOSEST TO THE CENTERLINE OF THE ROADWAY
- B. LOOP #1 IS THE LOOP IN THE LANE CLOSEST TO THE INTERSECTION.
- C. LABEL LOOP CABLE "IN" OR LOOP CABLE "OUT".
- D. LABEL LOOP CABLE CLOCKWISE OR LOOP CABLE COUNTERCLOCKWISE.

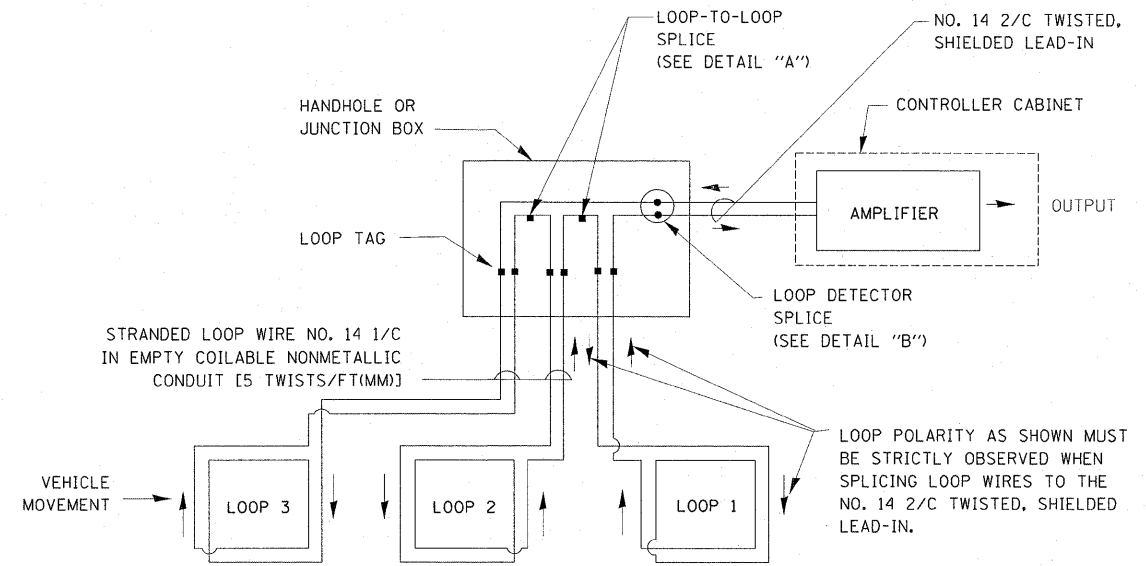

DETECTOR LOOP WIRING SCHEMATIC

- LOOPS SHALL BE SPLICED IN SERIES.
- SAW-CUTS SHALL BE A MINIMUM WIDTH OF 5/16" (8 mm).
- SAW-CUT DEPTHS SHALL BE 3" (75 mm). IF IN CONCRETE, THE SAW-CUT DEPTH SHALL BE TO THE TOP OF THE REINFORCEMENT.
- LOOP CORNERS SHALL BE DRILLED WITH A 2" (50 mm) DIAMETER CORE.

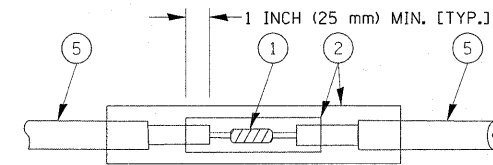

DETAIL "A" LOOP-TO-LOOP SPLICE

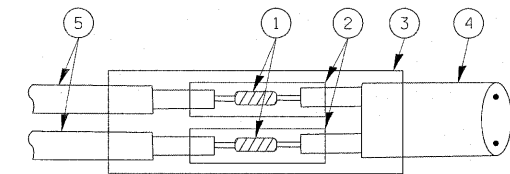

DETAIL "B" LOOP-TO-CONTROLLER SPLICE

TYPE I LOOP

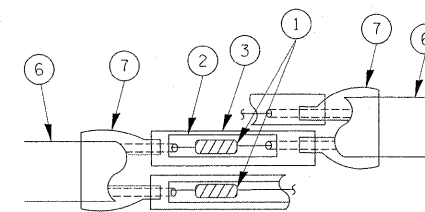

DETAIL "A" LOOP-TO-LOOP SPLICE

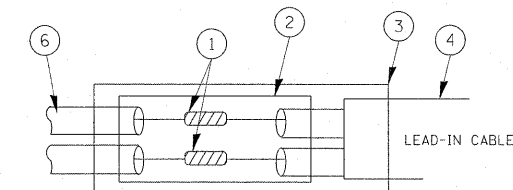

DETAIL "B" LOOP-TO-CONTROLLER SPLICE

LOOP DETECTOR SPLICE

- 1 WESTERN UNION SPLICE SOLDERED WITH ROSIN CORE FLUX. ALL EXPOSED SURFACES OF THE SOLDER SHALL BE SMOOTH.
- 2 WCSMW 30/100 HEAT SHRINK TUBE, MINIMUM LENGTH 3" (75 mm), UNDERWATER GRADE.
- 3 WCS 200/750 HEAT SHRINK TUBE, MINIMUM LENGTH 6" (150 mm), UNDERWATER GRADE.
- 4 NO. 14 2/C TWISTED, SHIELDED CABLE.
- 5 LOOP CONDUCTOR WITH FLEXIBLE PLASTIC TUBE.
- 6 PRE-FORMED LOOP
- 7 XL POLYOLEFIN 2 CONDUCTOR BREAKOUT SEALS. TYCO CBR-2 OR APPROVED EQUAL

FILE NAME =	USER NAME = qureshiya	DESIGNED - DAD	REVISED -	STATE OF ILLINOIS DEPARTMENT OF TRANSPORTATION	DISTRICT ONE STANDARD TRAFFIC SIGNAL DESIGN DETAILS			F.A.P. R.T.E.	SECTION	COUNTY	TOTAL SHEETS	SHEET NO.
c:\pw_work\pwt\dot\qureshiya\d0212316\01st.dgn		DRAWN - BCK	REVISED -		SCALE: NONE	SHEET NO. 1 OF 6 SHEETS	STA.	TO STA.	2010-133-1	WILL	54	46
		CHECKED - DAD	REVISED -					TS-05		CONTRACT NO. 60F75		
		DATE - 10-28-09	REVISED -		FED. ROAD DIST. NO. 1 ILLINOIS FED. AID PROJECT							

TRAFFIC SIGNAL MAST ARM AND SIGNAL POST

MAST ARM MOUNTED SIGNALS IN EXISTING, PROPOSED OR FUTURE SIDEWALK/BICYCLE PATH AREA. INTERSECTION SHOWN WITH PEDESTRIAN SIGNALS AND PEDESTRIAN PUSHBUTTON DETECTORS.

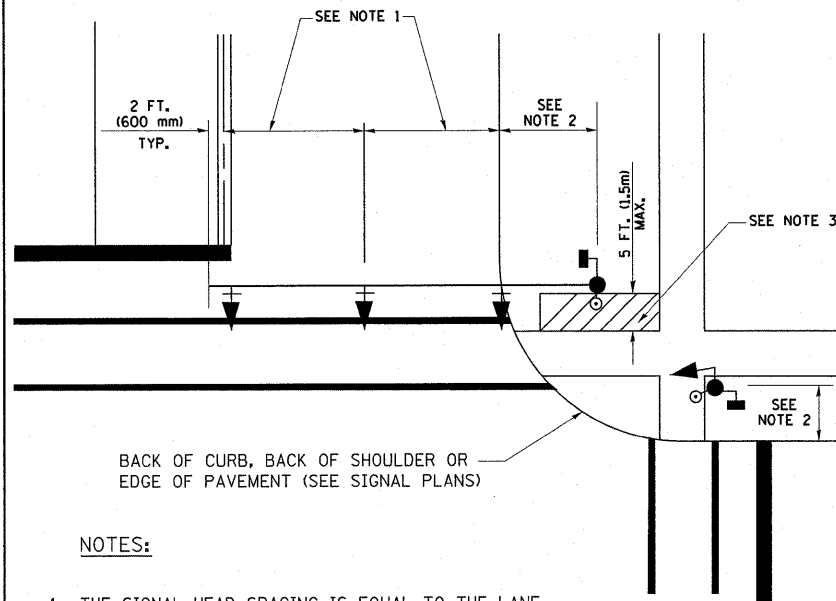

BACK OF CURB, BACK OF SHOULDER OR EDGE OF PAVEMENT (SEE SIGNAL PLANS)

NOTES:

1. THE SIGNAL HEAD SPACING IS EQUAL TO THE LANE WIDTH OR AS SHOWN ON THE TRAFFIC SIGNAL PLAN.
2. REFER TO THE TRAFFIC SIGNAL EQUIPMENT OFFSET TABLE.
3. PROVIDE A LEVEL ALL-WEATHER SURFACE (CONCRETE SIDEWALK, ASPHALT BICYCLE PATH SURFACE OR MATCHING MATERIAL TO THE ADJACENT SURFACE) UP TO THE MAST ARM SHAFT OR THE SIGNAL POST.
4. THE FACE OF THE PEDESTRIAN PUSHBUTTON SHALL BE PARALLEL TO THE CROSSWALK TO BE USED.
5. THE LOCATIONS AND INSTALLATION OF PEDESTRIAN SIGNAL HEADS AND PEDESTRIAN PUSHBUTTONS SHALL MEET THE REQUIREMENTS OF THE MUTCD AND INFORMATION FOUND IN THE "AMERICANS WITH DISABILITIES ACT ACCESSIBILITY GUIDELINES FOR BUILDINGS AND FACILITIES."

PEDESTRIAN SIGNAL POST AND PEDESTRIAN PUSH BUTTON POST

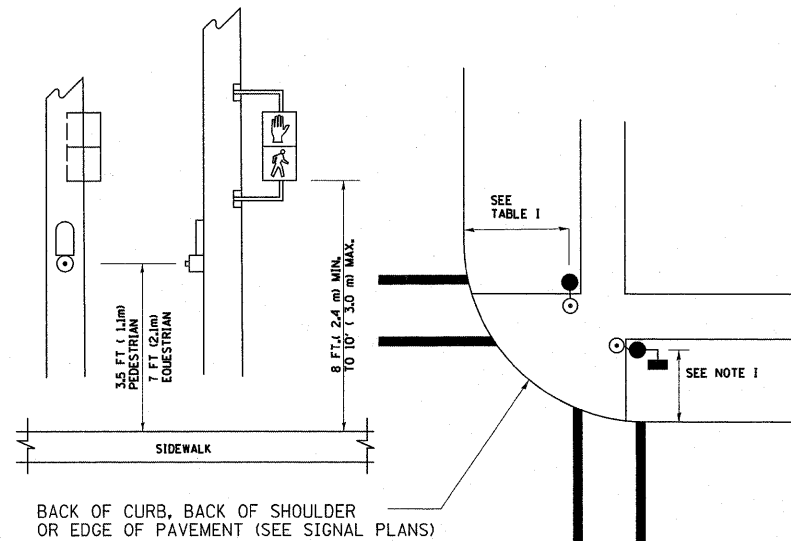

BACK OF CURB, BACK OF SHOULDER OR EDGE OF PAVEMENT (SEE SIGNAL PLANS)

NOTES:

1. REFER TO THE TRAFFIC SIGNAL EQUIPMENT OFFSET TABLE.
2. PROVIDE A LEVEL ALL-WEATHER SURFACE (CONCRETE SIDEWALK, ASPHALT BICYCLE PATH SURFACE OR MATCHING MATERIAL TO THE ADJACENT SURFACE) UP TO THE PEDESTRIAN SIGNAL POST OR THE PEDESTRIAN PUSH BUTTON POST.
3. THE FACE OF THE PEDESTRIAN PUSHBUTTON SHALL BE PARALLEL TO THE CROSSWALK TO BE USED.
4. THE LOCATIONS AND INSTALLATION OF PEDESTRIAN SIGNAL HEADS AND PEDESTRIAN PUSHBUTTONS SHALL MEET THE REQUIREMENTS OF THE MUTCD AND INFORMATION FOUND IN THE "AMERICANS WITH DISABILITIES ACT ACCESSIBILITY GUIDELINES FOR BUILDINGS AND FACILITIES."

RECOMMENDED PUSHBUTTON LOCATIONS

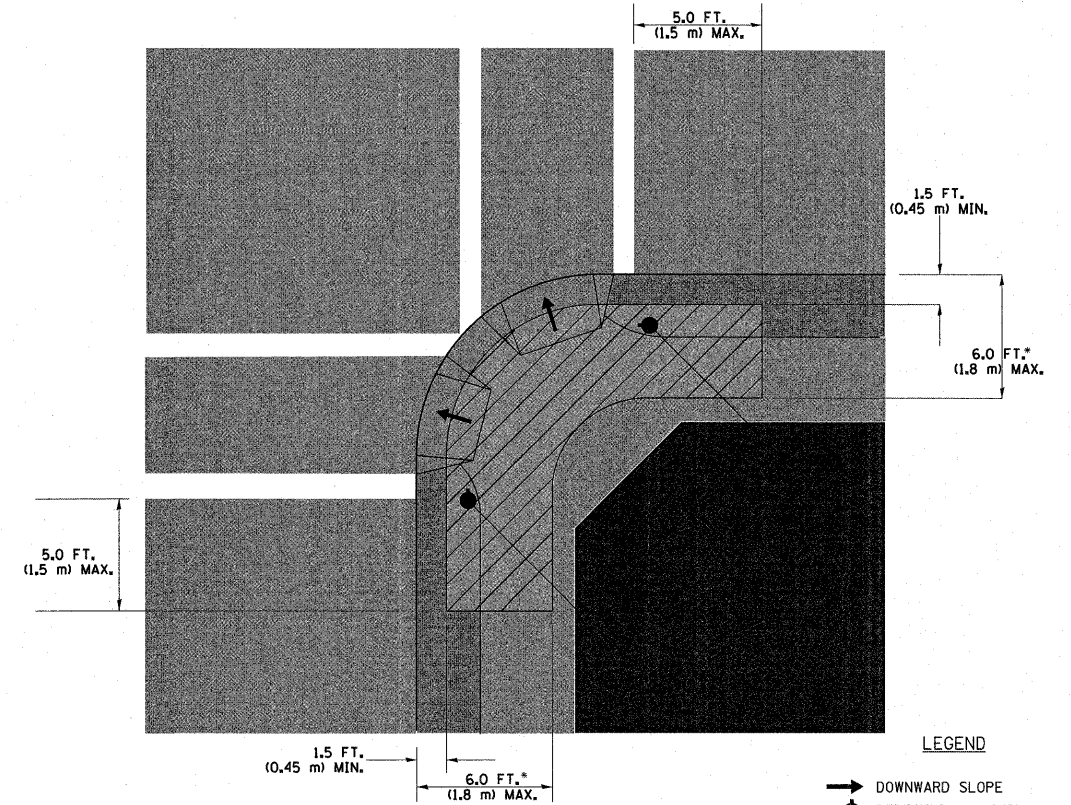

LEGEND

- DOWNWARD SLOPE
- PEDESTRIAN PUSHBUTTON
- ▨ RECOMMENDED PUSHBUTTON LOCATIONS

- WHERE THERE ARE CONSTRAINTS THAT MAKE IT IMPRACTICAL TO PLACE THE PEDESTRIAN PUSHBUTTON BETWEEN 1.5 FT (0.45 m) AND 6 FT (1.8 m) FROM THE EDGE OF THE CURB, SHOULDER, OR PAVEMENT, IT SHOULD NOT BE FURTHER THAN 10 FT (3 m) FROM THE EDGE OF CURB, SHOULDER, OR PAVEMENT.
- WHERE THERE ARE CONSTRAINTS ON A PARTICULAR CORNER THAT MAKE IT IMPRACTICAL TO PROVIDE THE 10 FT (3 m) SEPERATION BETWEEN THE TWO PEDESTRIAN PUSHBUTTONS, THE PUSHBUTTONS MAY BE PLACED CLOSER TOGETHER OR ON THE SAME POLE.

NOTES:

1. PEDESTRIAN SIGNAL HEADS SHALL BE MOUNTED WITH THE BOTTOM OF THE SIGNAL HOUSING INCLUDING BRACKETS NOT LESS THAN 8 FT (2.4 m) OR MORE THAN 10 FT (3 m) ABOVE SIDEWALK LEVEL, AND SHALL BE POSITIONED AND ADJUSTED TO PROVIDE MAXIMUM VISIBILITY AT THE BEGINNING OF THE CONTROLLED CROSSWALK.
2. THE BOTTOM OF THE SIGNAL HOUSING (INCLUDING BRACKETS) OF A VEHICULAR SIGNAL FACE THAT IS NOT LOCATED OVER A HIGHWAY SHALL BE AT LEAST 8 FT (2.4 m) BUT NOT MORE THAN 19 FT (5.8 m) ABOVE THE SIDEWALK OR, IF THERE IS NO SIDEWALK, ABOVE THE PAVEMENT GRADE AT THE CENTER OF THE ROADWAY.
3. THE BOTTOM OF THE SIGNAL HOUSING AND ANY RELATED ATTACHMENTS TO A SIGNAL FACE LOCATED OVER ANY PORTION OF A HIGHWAY SHALL BE ACCORDING TO CURRENT STATE STANDARDS 877001, 877002, 877006, 877011 AND 877012 WITH A MINIMUM OF 16 FT (5.0 m) AND A MAXIMUM OF 18 FT. (5.5 m) FROM THE HIGHEST POINT OF PAVEMENT.
4. THE BOTTOM OF THE TEMPORARY SPAN WIRE MOUNTED SIGNAL HOUSING AND ANY RELATED ATTACHMENTS TO A SIGNAL FACE LOCATED OVER ANY PORTION OF A HIGHWAY SHALL BE ACCORDING TO CURRENT STATE STANDARD 880001 WITH A MINIMUM OF 17 FT (5.18 m) FROM THE HIGHEST POINT OF PAVEMENT.
5. THE TOP OF THE SIGNAL HOUSING OF A SIGNAL FACE LOCATED OVER ANY PORTION OF A HIGHWAY SHALL NOT BE MORE THAN 25.6 FT (7.8 m) ABOVE THE PAVEMENT.

TRAFFIC SIGNAL EQUIPMENT OFFSET

TRAFFIC SIGNAL EQUIPMENT	COMBINATION CONCRETE CURB AND GUTTER (MINIMUM DISTANCE FROM BACK OF CURB TO CENTERLINE OF FOUNDATION)	SHOULDER/NON-CURBED AREA (MINIMUM DISTANCE FROM EDGE OF PAVEMENT TO CENTERLINE OF FOUNDATION)
TRAFFIC SIGNAL MAST ARM POLE	6 FT (1.8m)	SHOULDER WIDTH + 2 FT (0.6m), MINIMUM 10 FT (3.0m)
TRAFFIC SIGNAL POST	4 FT (1.2m)	SHOULDER WIDTH + 2 FT (0.6m), MINIMUM 10 FT (3.0m)
PEDESTRIAN SIGNAL POST	4 FT (1.2m)	SHOULDER WIDTH + 2 FT (0.6m), MINIMUM 10 FT (3.0m)
PEDESTRIAN PUSHBUTTON POST	4 FT (1.2m)	SHOULDER WIDTH + 2 FT (0.6m), MINIMUM 10 FT (3.0m)
TEMPORARY WOOD POLE	6 FT (1.8m)	SHOULDER WIDTH + 2 FT (0.6m), MINIMUM 10 FT (3.0m)
CONTROLLER CABINET	6 FT (1.8m) MINIMUM DISTANCE SEE NOTE 2	SHOULDER WIDTH + 6 FT (1.8m), MINIMUM 16 FT (4.9m) SEE NOTE 3.
SERVICE INSTALLATION, GROUND MOUNT	6 FT (1.8m) MINIMUM DISTANCE SEE NOTE 2	SHOULDER WIDTH + 6 FT (1.8m), MINIMUM 16 FT (4.9m) SEE NOTE 3.

NOTES:

1. CONTACT THE "AREA TRAFFIC SIGNAL MAINTENANCE AND OPERATIONS ENGINEER" FOR ASSISTANCE IN LOCATING THE TRAFFIC SIGNAL EQUIPMENT WHEN THERE ARE CONFLICTS WITH DITCHES OR THE MINIMUM OFFSET DISTANCES CANNOT BE MET.
2. MINIMUM DISTANCE FROM THE BACK OF CURB TO THE ROADWAY SIDE OF THE FOUNDATION.
3. MINIMUM DISTANCE FROM THE EDGE OF PAVEMENT TO THE ROADWAY SIDE OF THE FOUNDATION.
4. ANY CHANGES TO THE OFFSETS OF THE FOUNDATIONS, FROM THE MINIMUM DISTANCES LISTED IN THE "TRAFFIC SIGNAL EQUIPMENT OFFSET" CHART AND THE TRAFFIC SIGNAL INSTALLATION PLAN, COULD EFFECT THE PLACEMENT OF THE SIGNAL HEADS, PEDESTRIAN SIGNAL HEADS AND THE PEDESTRIAN PUSHBUTTONS. THE SIGNAL HEAD PLACEMENT ON THE MAST ARMS SHALL REMAIN AS PER THE TRAFFIC SIGNAL INSTALLATION PLAN AND THE "TRAFFIC SIGNAL MAST ARM AND SIGNAL POST" DETAIL ABOVE. THE PROPOSED MAST ARM LENGTHS MAY NEED TO BE REVISED TO MEET THE ABOVE REQUIREMENTS. THE PEDESTRIAN SIGNAL HEADS AND PEDESTRIAN PUSHBUTTONS MUST MEET THE REQUIREMENTS UNDER THE DETAILS ON THIS SHEET.

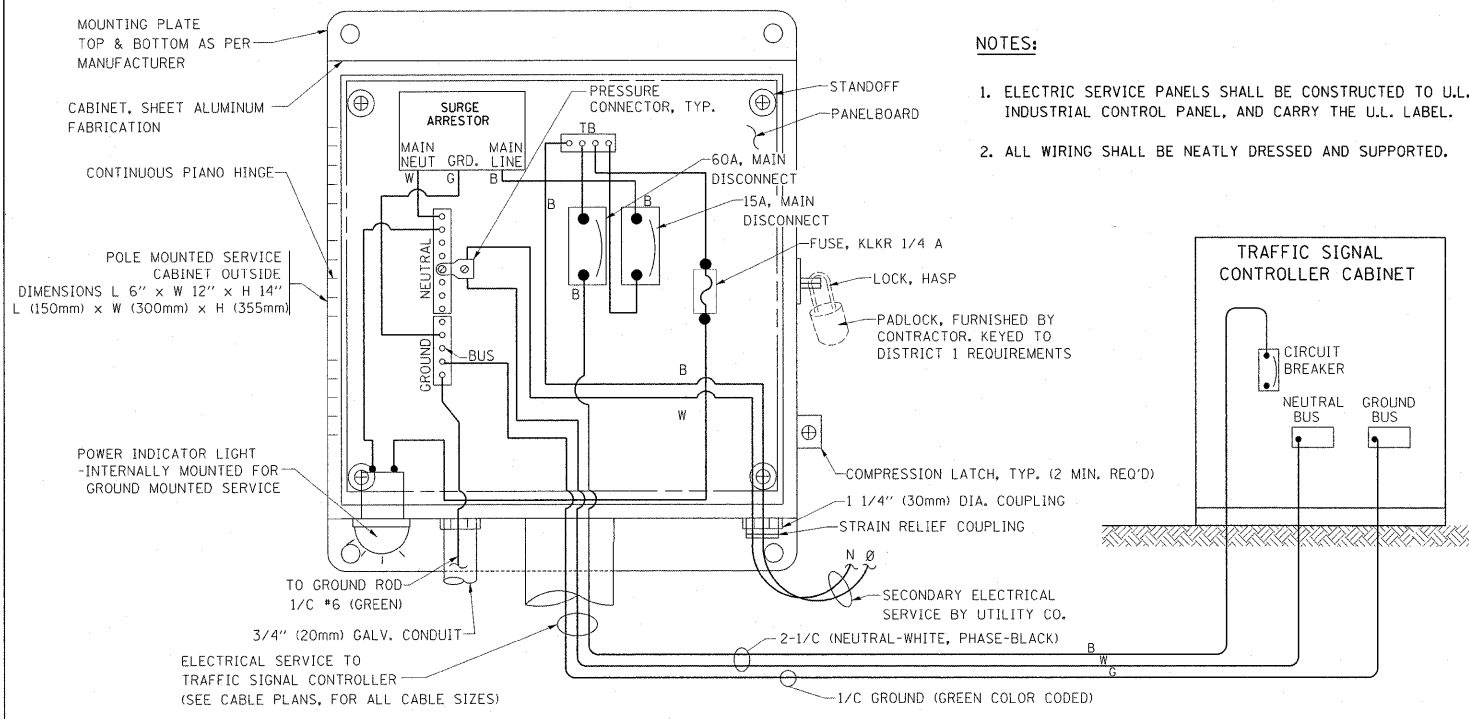

ELECTRICAL SERVICE – PANEL DIAGRAM (TYPICAL FOR POLE AND GROUND MOUNTED SERVICE)
SERVICE INSTALLATION POLE MOUNT (SHOWN)
 (NOT TO SCALE)

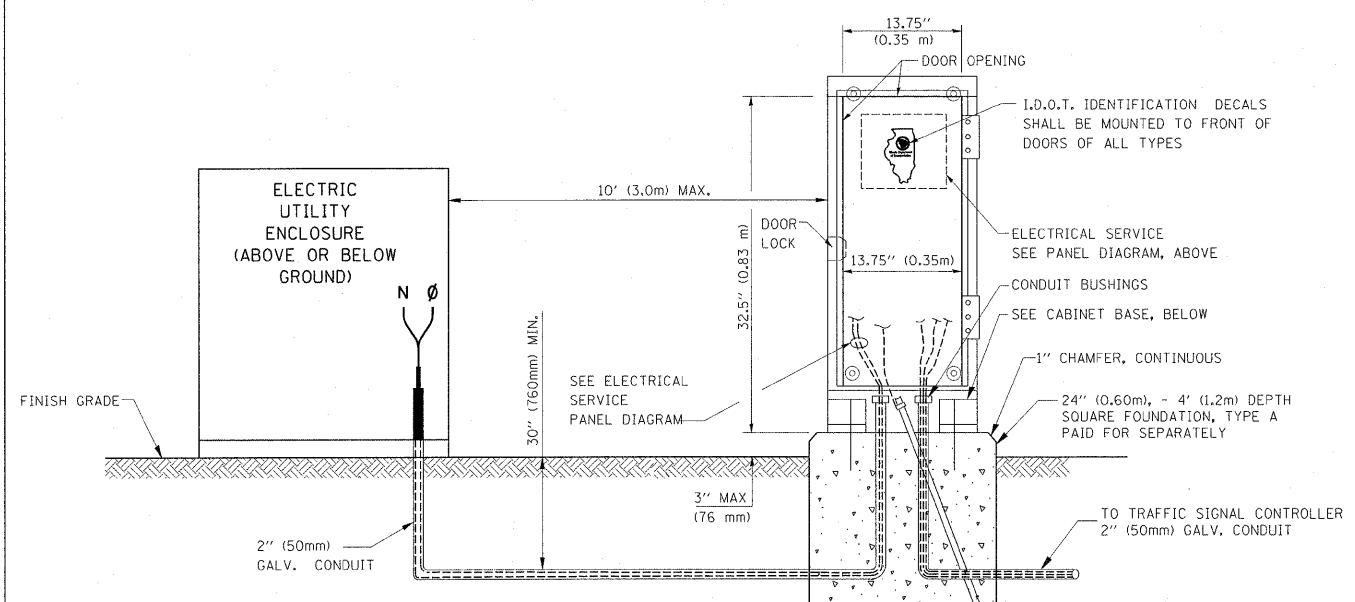

SERVICE INSTALLATION GROUND MOUNT
 (NOT TO SCALE)

CABINET – BASE BOLT PATTERN
 (NOT TO SCALE)

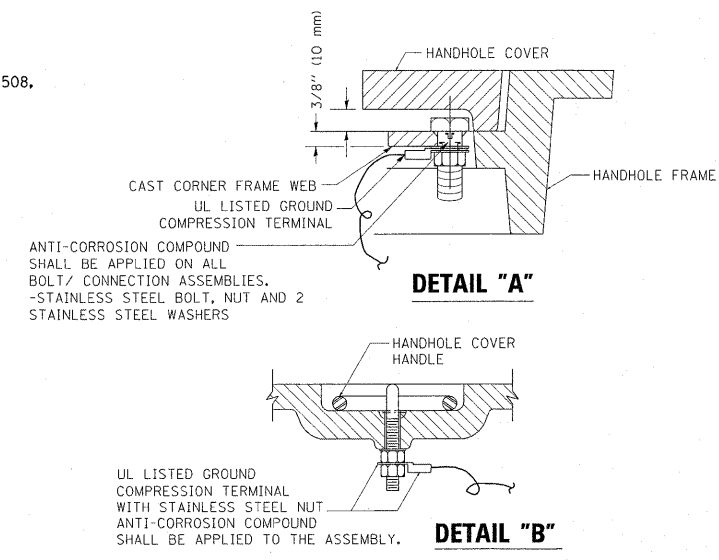

- NOTES:**
- GROUNDING SYSTEM**
1. THE GROUNDING SYSTEM SHALL CONSIST OF AN INSULATED CONDUCTOR TYPE XLP, NO. 6 A.W.G., STRANDED COPPER TO BE INSTALLED IN RACEWAYS. THE GROUNDING CABLE SHALL BE INSTALLED IN A CONTINUOUS MANNER AS SHOWN ON THE CABLE PLAN PROVIDED. ALL GROUNDING CONDUCTORS SHALL BE BONDED TO METAL ENCLOSURE (HANDHOLE, POST, MAST ARM, CONTROLLER, ETC.). GROUND ROD SHALL BE 3/4" DIA. x 10'-0" (20mm x 3.0m) LONG, COPPER CLAD. ONE GROUND ROD SHALL BE INSTALLED AT ALL POST FOUNDATIONS, POLE FOUNDATIONS, CONTROLLER CABINET FOUNDATION AND ELECTRICAL SERVICE INSTALLATION AS INDICATED ON THE CABLE PLAN. IF THERE ARE ANY SPECIAL CONDITIONS SUCH AS SUB-SURFACE CONDITIONS OR INSTALLATION PROBLEMS, THE RESIDENT ENGINEER SHALL BE NOTIFIED OR CONTACT THE BUREAU OF TRAFFIC, ILLINOIS DEPARTMENT OF TRANSPORTATION DISTRICT ONE AT (847) 705-4139.
 2. THE NEUTRAL CONDUCTOR AND THE GROUND CONDUCTOR SHALL BE CONNECTED IN THE SERVICE INSTALLATION. AT NO OTHER POINT IN THE TRAFFIC SIGNAL SYSTEM SHALL THE NEUTRAL AND GROUND CONDUCTORS BE CONNECTED.
 3. ALL EQUIPMENT GROUNDING CONDUCTORS SHALL TERMINATE AT THE GROUND BUS IN THE CONTROLLER CABINET.
 4. THE CONTRACTOR SHALL PROVIDE A GROUND CABLE WITH CONNECTORS BETWEEN THE HANDHOLE COVER AND HANDHOLE FRAME.

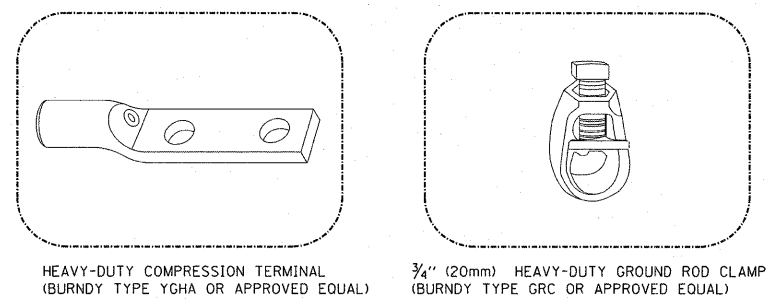
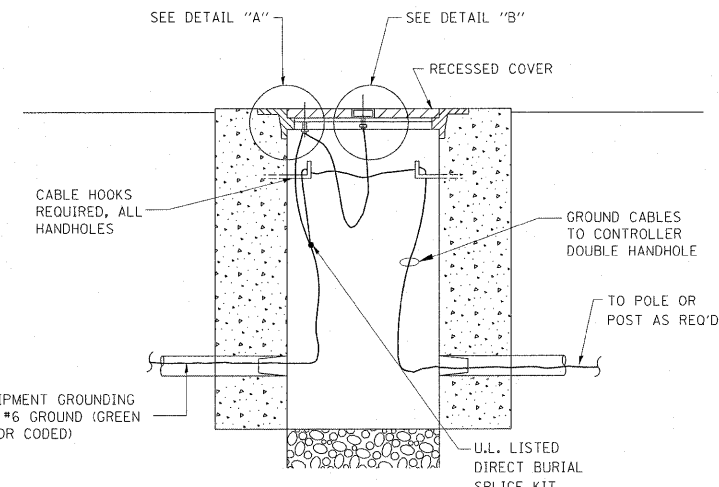

- NOTES:**
- ALL CLAMPS SHALL BE BRONZE OR COPPER, UL APPROVED.
 - GROUND CABLE SHALL BE LOOPED OVER HOOKS IN THE HANDHOLES. 6.5' (2.0m) SLACK SHALL BE PROVIDED IN SINGLE HANDHOLES. 13' (4.0m) OF SLACK SHALL BE PROVIDED IN DOUBLE HANDHOLES. 5' (1.4m) OF SLACK SHALL BE PROVIDED BETWEEN FRAME AND COVER.

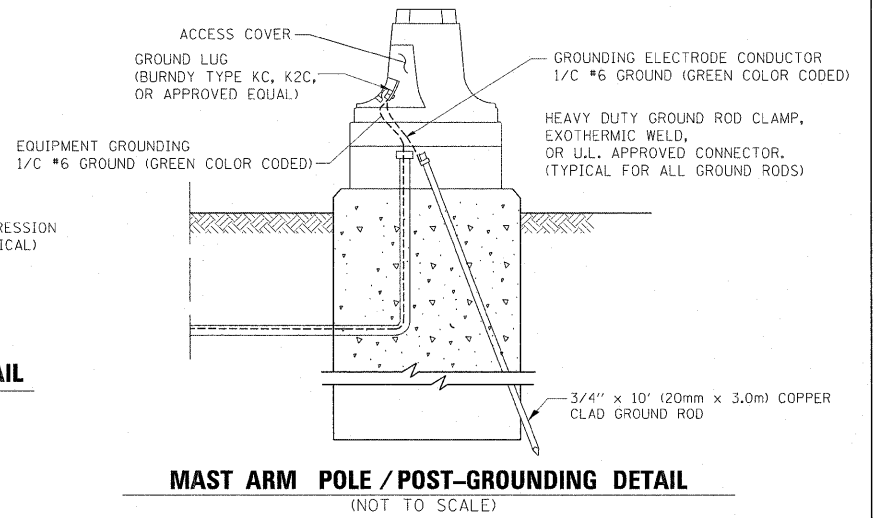
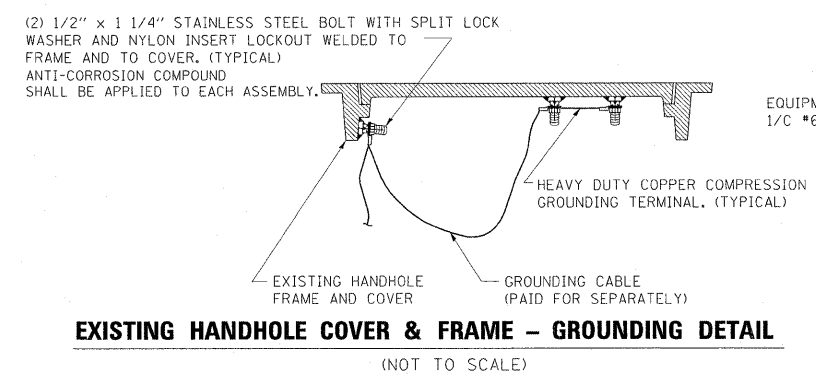

FILE NAME =	USER NAME = qureshiya	DESIGNED - DAD	REVISED -
at:\pwork\pwork\qureshiya\2012\316\01\std.dgn		DRAWN - BCK	REVISED -
		CHECKED - DAD	REVISED -
		DATE - 10-28-09	REVISED -

STATE OF ILLINOIS
DEPARTMENT OF TRANSPORTATION

DISTRICT ONE
STANDARD TRAFFIC SIGNAL DESIGN DETAILS

SCALE: NONE SHEET NO. 3 OF 6 SHEETS STA. TO STA.

F.A.P. RTE.	SECTION	COUNTY	TOTAL SHEETS	SHEET NO.
	2010-133-1	WILL	54	48
TS-05		CONTRACT NO. 60F75		
FED. ROAD DIST. NO. 1 ILLINOIS FED. AID PROJECT				

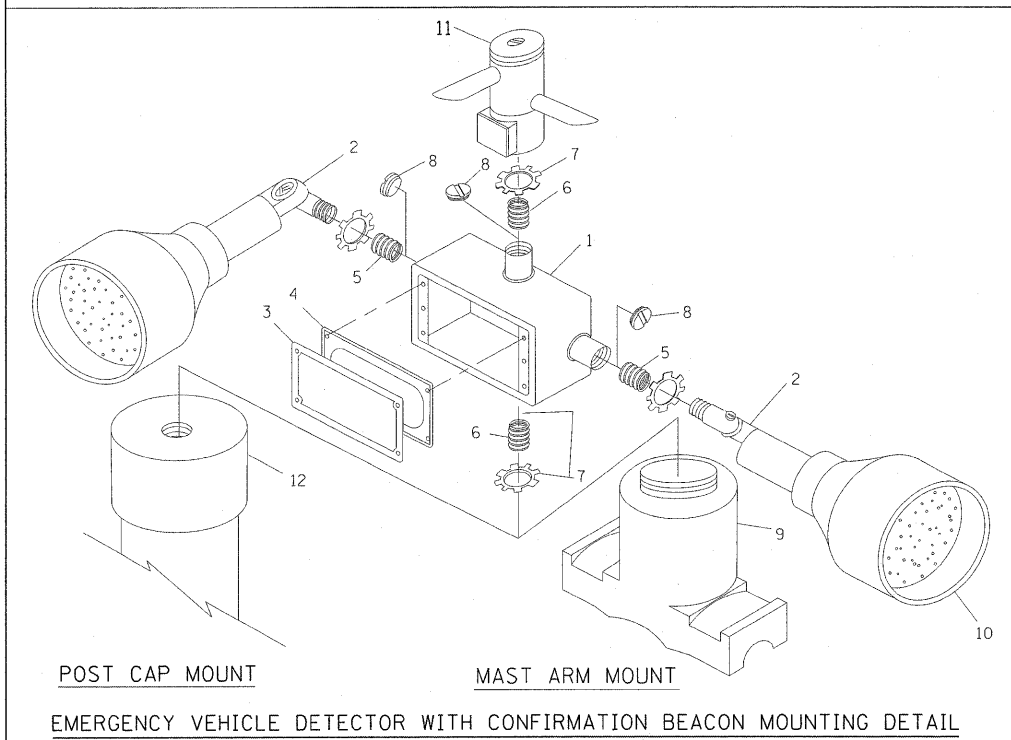
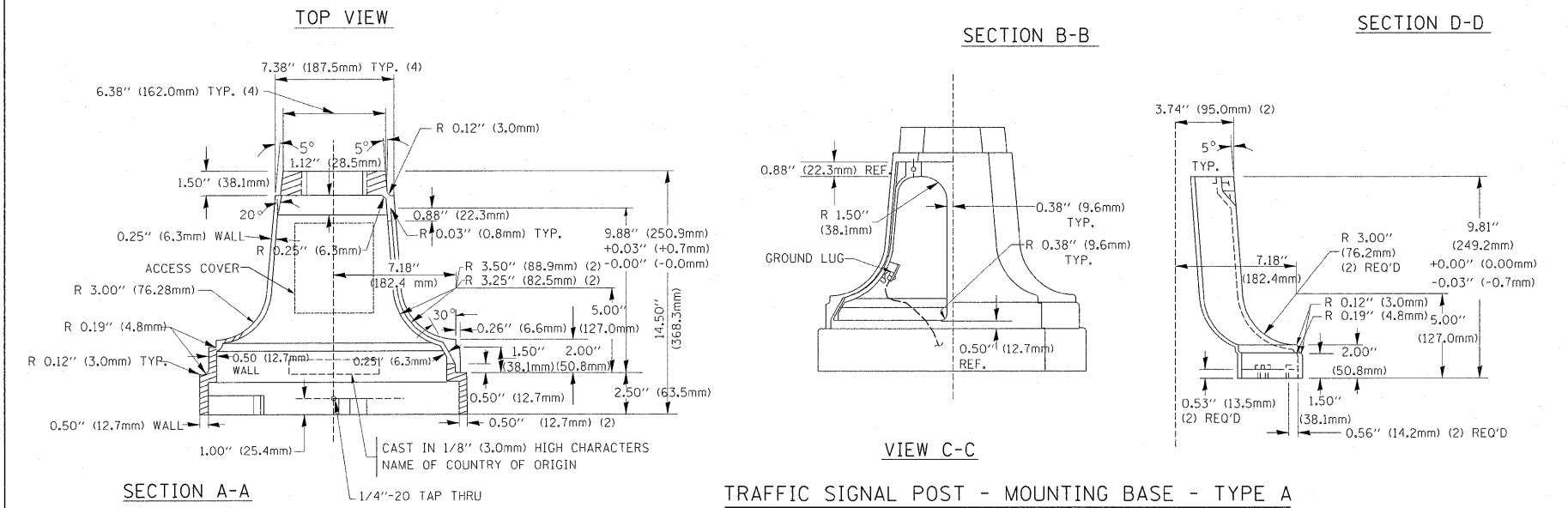
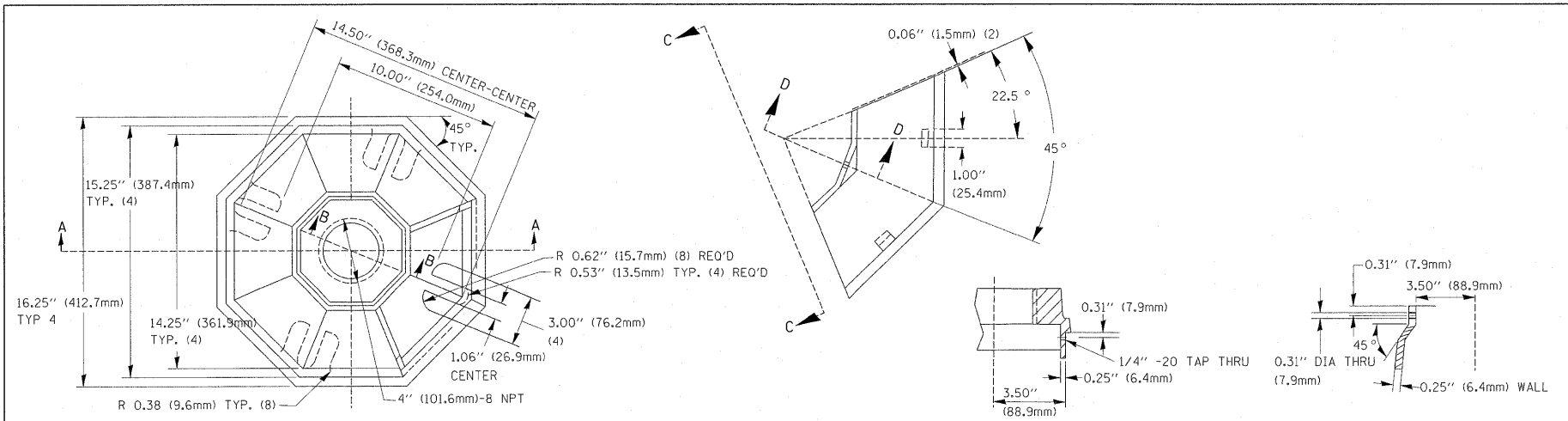

ITEM NO.	IDENTIFICATION
1	OUTLET BOX- GALV. 21 CU.IN. (0.000344 CU-M)
2	LAMP HOLDER AND COVER
3	OUTLET BOX COVER
4	RUBBER COVER GASKET
5	REDUCING BUSHING
6	3/4\" (19 mm) CLOSE NIPPLE
7	3/4\" (19 mm) LOCKNUT
8	3/4\" (19 mm) HOLE PLUG
9	SADDLE BRACKET - GALV.
10	6 WATT PAR 38 LED FLOOD LAMP
11	DETECTOR UNIT
12	POST CAP [18 FT. (5.4 m) POST MIN.]

- NOTES:**
- ALL ELECTRICAL ITEMS, EXCEPT ITEMS #2 AND #11 SHALL BE ALUMINUM OR GALVANIZED
 - ITEM #1- OZ/GEDNEY FSX-1-50 OR EQUIVALENT
ITEM #2- MULBERRY CON-O-SHADE LAMP SHIELD OR EQUIVALENT
ITEM #9- "BAND-IT" SADDLE BRACKET OR EQUIVALENT
 - WHEN POST MOUNTING IS SPECIFIED, ITEM #9 SHALL NOT BE REQUIRED. THE DETECTION UNIT SHALL BE MOUNTED DIRECTLY ON TOP OF THE CAP BY DRILLING AND TAPPING A 3/4\" (19 mm) HOLE WITH PIPE THREADS. THE POST CAP SHALL EITHER BE SCREWED TO THE TOP OF THE POST OR A MINIMUM OF 3 TIGHTENING SCREWS SHALL BE REQUIRED ON EACH CAP.

FILE NAME =	USER NAME = qureshiya	DESIGNED - DAD	REVISED -
cd:\pw\work\pwsdot\qureshiya\2012\2316\01\2316.dgn		DRAWN - BCK	REVISED -
PLOT SCALE = 50.6394 ' / IN.		CHECKED - DAD	REVISED -
PLOT DATE = 10/26/2010		DATE - 10-28-09	REVISED -

**STATE OF ILLINOIS
DEPARTMENT OF TRANSPORTATION**

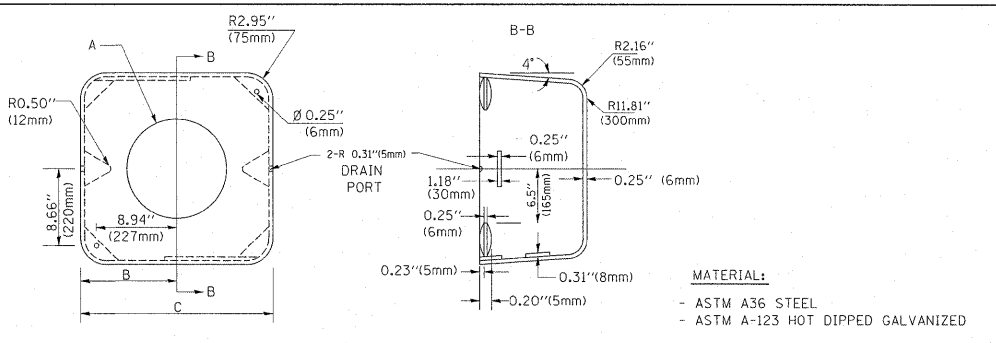

A	B	C	HEIGHT	WEIGHT
VARIABLES	9.5\" (241mm)	19\" (483mm)	7\" (178mm) - 12\" (300mm)	53 lbs (24kg)
VARIABLES	10.75\" (273mm)	21.5\" (546mm)	7\" (178mm) - 12\" (300mm)	68 lbs (31 kg)
VARIABLES	13.0\" (330mm)	26\" (660mm)	7\" (178mm) - 12\" (300mm)	81 lbs (37 kg)
VARIABLES	18.5\" (470mm)	37\" (940mm)	7\" (178mm) - 12\" (300mm)	126 lbs (57 kg)

- NOTES:**
- DIMENSION "A" IS EQUAL TO THE DIAMETER OF THE MAST ARM POLE AT THE TOP OF THE SHROUD. THE SHROUD SHALL BE TIGHT TO THE MAST ARM POLE.
 - THE SUPPLIER SHALL VERIFY THE ABOVE DIMENSIONS BASED ON MAST ARM REQUIREMENTS.
 - THE HEIGHT OF THE SHROUD SHALL COVER THE ANCHOR BOLTS, NUTS AND MAST ARM POLE BASE.

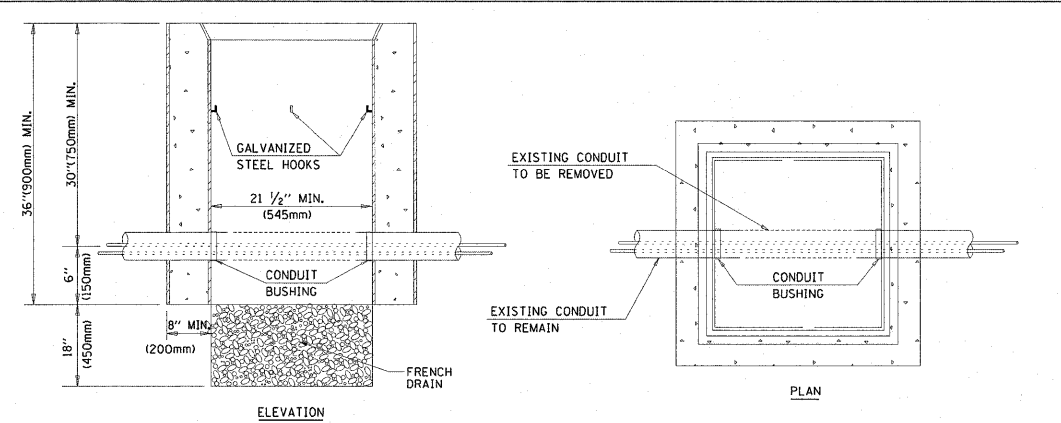
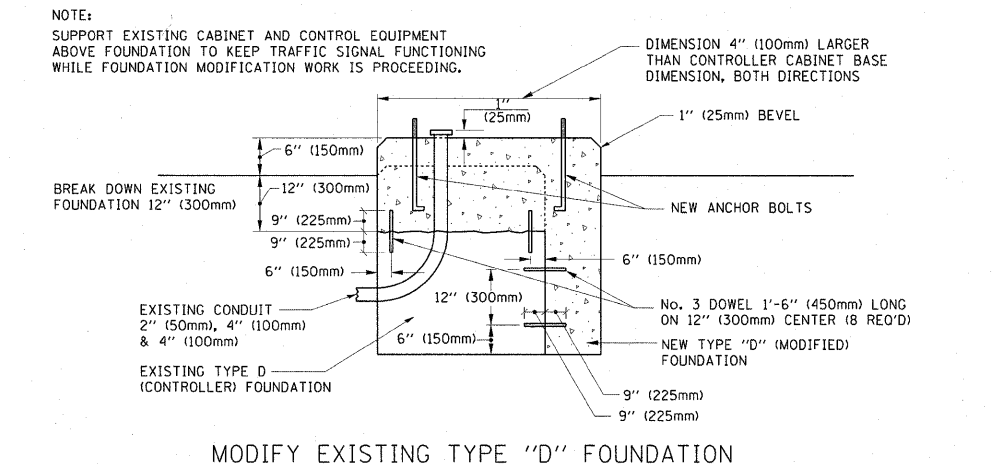

- NOTES:**
- HANDHOLE CONSTRUCTED PER STATE STANDARD 814001.
 - REMOVAL OF THE EXISTING CONDUIT FROM THE HANDHOLE AND THE INSTALLATION OF THE CONDUIT BUSHINGS SHALL BE INCIDENTAL TO THE HANDHOLE.

SCALE: NONE	SHEET NO. 4 OF 6 SHEETS	STA.	TO STA.	DISTRICT ONE		F.A.P. RTE.	COUNTY	TOTAL SHEETS	SHEET NO.
				STANDARD TRAFFIC SIGNAL DESIGN DETAILS		2010-133-I	WILL	54	49
						TS-05	CONTRACT NO. 60F75		
				FED. ROAD DIST. NO. 1 ILLINOIS FED. AID PROJECT					
				846/357					

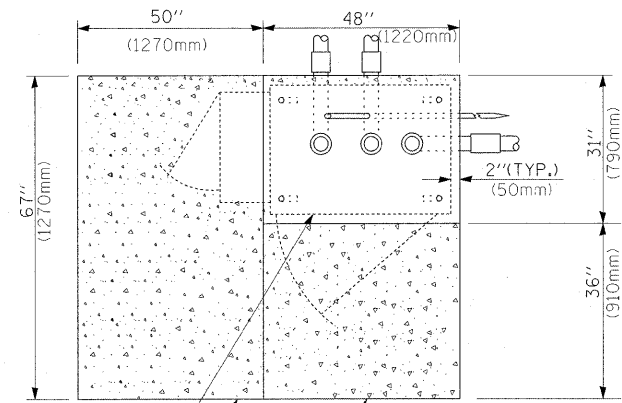

TOP VIEW

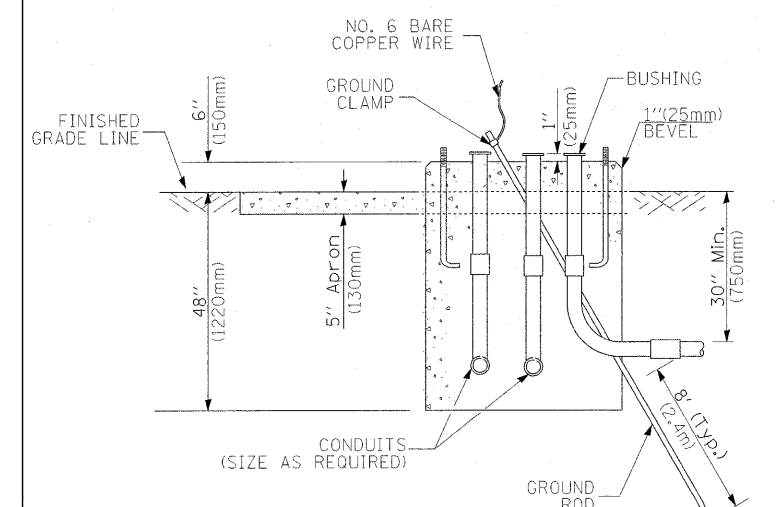

TYPE D
FOR GROUND MOUNTED
CONTROLLER CABINET
AND UPS BATTERY CABINET

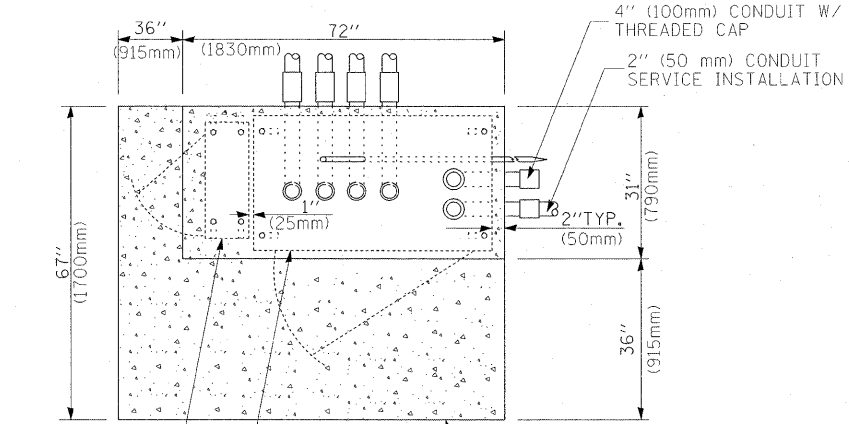

TOP VIEW

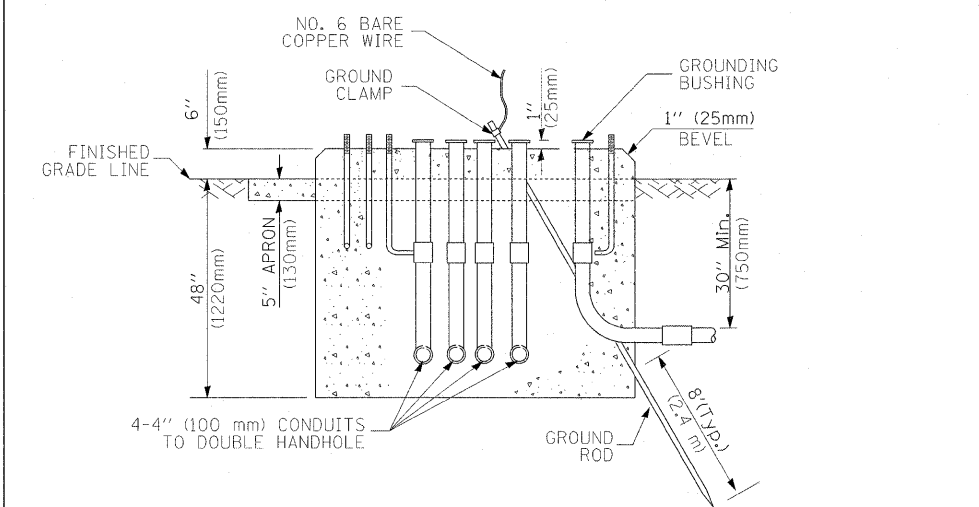

TYPE C
FOR GROUND MOUNTED
CONTROLLER CABINET
AND UPS BATTERY CABINET

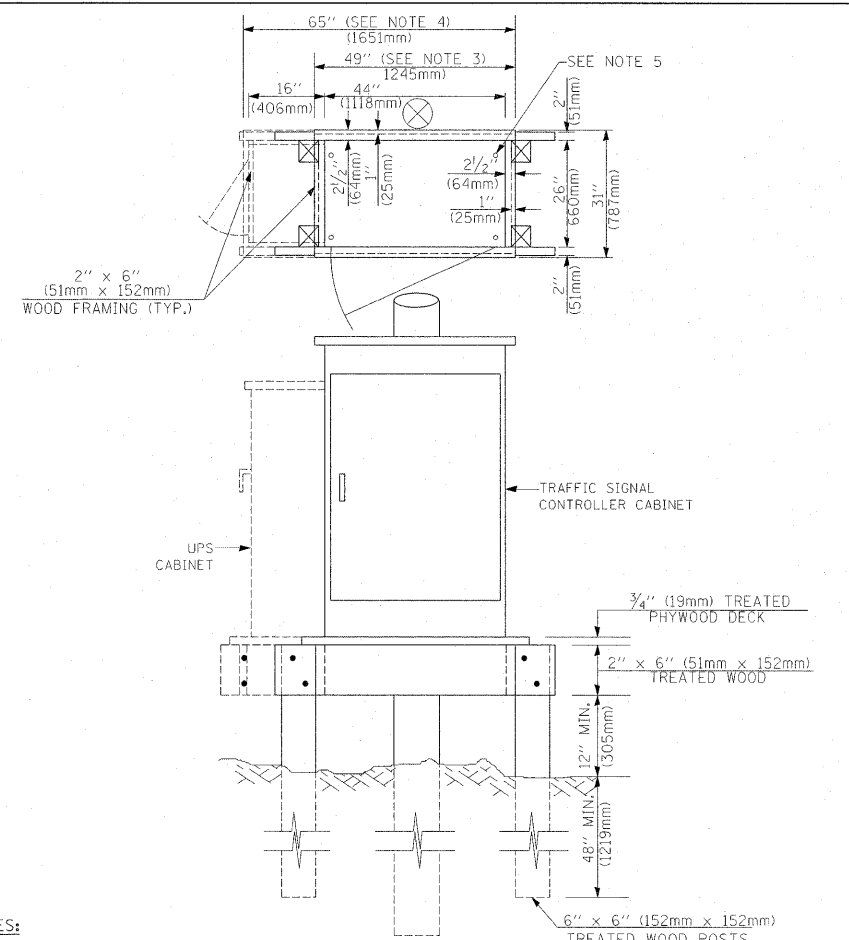

TEMPORARY SIGNAL CONTROLLER
WOOD SUPPORT PLATFORM

- NOTES:
1. BASED ON CONTROLLER CABINET TYPE IV WITH BASE DIMENSIONS OF 26" x 44" (660mm x 635mm). ADJUST PLATFORM SIZE TO FIT CABINET BASE DIMENSIONS BEING SUPPLIED.
 2. BASED ON UNINTERRUPTIBLE POWER SUPPLY CABINET WITH BASE DIMENSIONS OF 16" x 25" (406mm x 635mm). ADJUST PLATFORM SIZE TO FIT CABINET BASE DIMENSIONS BEING SUPPLIED.
 3. PLATFORM SIZE FOR CONTROLLER CABINET TYPE IV.
 4. PLATFORM SIZE FOR CONTROLLER CABINET TYPE IV AND UNINTERRUPTIBLE POWER SUPPLY CABINET.
 5. DRILLED HOLES THROUGH THE PLATFORM BASE TO MATCH THE CONTROLLER CABINET BOLT TEMPLATE. FASTEN THE CONTROLLER CABINET TO THE PLATFORM WITH CARRIAGE BOLTS, WASHERS AND NUTS.
 6. FASTEN ALL SUPPORT WOOD FRAMING TO THE WOOD POSTS WITH 2 LAG SCREWS FOR EACH CONNECTION.

CABLE SLACK LENGTH	FEET	METER
HANDHOLE	6.5	2.0
DOUBLE HANDHOLE	13.0	4.0
SIGNAL POST	2.0	0.6
MAST ARM	2.0	0.6
CONTROLLER CABINET	1.5	0.5
FIBER OPTIC AT CABINET	13.0	4.0
ELECTRIC SERVICE AT (CABINET OR SERVICE LOCATION)	1.5	0.5
GROUND CABLE (SIGNAL POST, MAST ARM, CABINET)	1.5	0.5
GROUND CABLE (BETWEEN FRAME AND COVER)	5.0	1.6

CABLE SLACK

VERTICAL CABLE LENGTH	FEET	METER
MAST ARM POLE (MAST ARM MOUNTED SIGNAL HEAD) (L = MAST ARM LENGTH - DISTANCE TO SIGNAL HEAD FROM END OF ARM)	20.0+L	6.0+L
BRACKET MOUNTED (MAST ARM POLE OR SIGNAL POLE)	13.0	4.0
PEDESTRIAN PUSH BUTTON	6.0	2.0
SERVICE INSTALLATION POLE MOUNT TO SERVICE DROP	13.5	4.1
SERVICE INSTALLATION POLE MOUNT TO GROUND	13.5	4.1
SERVICE INSTALLATION GROUND MOUNT	6.0	2.0
FOUNDATION (SIGNAL POST, MAST ARM POLE, CONTROLLER CABINET, SERVICE-GROUND MOUNT)	3.0	1.0

VERTICAL CABLE LENGTH

FOUNDATION	DEPTH
TYPE A - Signal Post	4'-0" (1.2m)
TYPE C - CONTROLLER W/ UPS	4'-0" (1.2m)
TYPE D - CONTROLLER	4'-0" (1.2m)
SERVICE INSTALLATION, GROUND MOUNT, TYPE A - SQUARE	4'-0" (1.2m)

DEPTH OF FOUNDATION

Mast Arm Length	① Foundation Depth	Foundation Diameter	Spiral Diameter	Quantity of Rebars	Size of Rebars
Less than 30' (9.1 m)	10'-0" (3.0 m)	30" (750mm)	24" (600mm)	8	6(19)
Greater than or equal to 30' (9.1 m) and less than 40' (12.2 m)	13'-6" (4.1 m)	30" (750mm)	24" (600mm)	8	6(19)
	11'-0" (3.4 m)	36" (900mm)	30" (750mm)	12	7(22)
Greater than or equal to 40' (12.2 m) and less than 50' (15.2 m)	13'-0" (4.0 m)	36" (900mm)	30" (750mm)	12	7(22)
	Greater than or equal to 50' (15.2 m) and up to 55' (16.8 m)	15'-0" (4.6 m)	36" (900mm)	12	7(22)
Greater than or equal to 56' (16.8 m) and less than 65' (19.8 m)	21'-0" (6.4 m)	42" (1060mm)	36" (900mm)	16	8(25)
	Greater than or equal to 65' (19.8 m) and up to 75' (22.9 m)	25'-0" (7.6 m)	42" (1060mm)	16	8(25)

- NOTES:
1. These foundation depths are for sites which have cohesive soils (clayey silt, sandy clay, etc.) along the length of the shaft, with an average Unconfined Compressive Strength (Qu) > 1.0 tsf (100 kpa). This strength shall be verified by boring data prior to construction or with testing by the Engineer during foundation drilling. The Bureau of Bridges & structures should be contacted for a revised design if other conditions are encountered.
 2. Combination mast arm assemblies under 55 feet (16.8 m) shall use 36" (900 mm) diameter foundations.
 3. Combination mast arm assemblies under 56 feet (16.8 m) through 75 feet (22.9 m) shall use 42" (1060 mm) diameter foundations.
 4. For mast arm assemblies with dual arms refer to state standard 878001.

DEPTH OF MAST ARM FOUNDATIONS, TYPE E

FILE NAME =	USER NAME = qureshija	DESIGNED - DAG	REVISED -	STATE OF ILLINOIS DEPARTMENT OF TRANSPORTATION	DISTRICT ONE STANDARD TRAFFIC SIGNAL DESIGN DETAILS			F.A.P. RTE.	SECTION	COUNTY	TOTAL SHEETS	SHEET NO.
c:\pwork\p\p\qureshija\d212316\01s	std.dgn	DRAWN - BCK	REVISED -		SCALE: NONE	SHEET NO. 5 OF 6 SHEETS	STA.	TO STA.	2010-133-1	WILL	54	50
		CHECKED - DAD	REVISED -					TS-05		CONTRACT NO. 60F75		
		DATE - 10-28-09	REVISED -					FED. ROAD DIST. NO. 1 ILLINOIS/FED. AID PROJECT				

TRAFFIC SIGNAL LEGEND

ITEM	REMOVAL	EXISTING	PROPOSED	ITEM	REMOVAL	EXISTING	PROPOSED	ITEM	REMOVAL	EXISTING	PROPOSED
CONTROLLER CABINET				EMERGENCY VEHICLE LIGHT DETECTOR				ELECTRIC CABLE IN CONDUIT, TRACER, NO. 14 1/C, UNLESS NOTED OTHERWISE			
RAILROAD CONTROL CABINET				CONFIRMATION BEACON				COAXIAL CABLE			
COMMUNICATIONS CABINET				HANDHOLE				VENDOR CABLE FOR CAMERA			
MASTER CONTROLLER				HEAVY DUTY HANDHOLE				COPPER INTERCONNECT CABLE, NO. 18 3 PAIR TWISTED, SHIELDED			
MASTER MASTER CONTROLLER				DOUBLE HANDHOLE				FIBER OPTIC CABLE NO. 62.5/125, MM12F			
UNINTERRUPTIBLE POWER SUPPLY				JUNCTION BOX				FIBER OPTIC CABLE NO. 62.5/125, MM12F SM12F			
SERVICE INSTALLATION, (P) POLE OR (G) GROUND MOUNT				GALVANIZED STEEL CONDUIT IN TRENCH (T) OR PUSHED (P)				FIBER OPTIC CABLE NO. 62.5/125, MM12F			
TELEPHONE CONNECTION (P) POLE OR (G) GROUND MOUNT				TEMPORARY SPAN WIRE, TETHER WIRE, AND CABLE				FIBER OPTIC CABLE NO. 62.5/125, (NUMBER OF FIBERS & TYPE TO BE NOTED ON PLANS)			
STEEL MAST ARM ASSEMBLY AND POLE				COMMON TRENCH				GROUND ROD AT (C) CONTROLLER, (H) HANDHOLE, (P) POST, (M) MAST ARM, OR (S) SERVICE			
ALUMINUM MAST ARM ASSEMBLY AND POLE				COILABLE NONMETALLIC CONDUIT (EMPTY)				CONTROLLER CABINET AND FOUNDATION TO BE REMOVED			
STEEL COMBINATION MAST ARM ASSEMBLY AND POLE WITH LUMINAIRE				SYSTEM ITEM		S	S	STEEL MAST ARM POLE AND FOUNDATION TO BE REMOVED			
STEEL COMBINATION MAST ARM ASSEMBLY AND POLE WITH PTZ CAMERA				INTERSECTION ITEM		I	IP	ALUMINUM MAST ARM POLE AND FOUNDATION TO BE REMOVED			
SIGNAL POST				REMOVE ITEM	R			STEEL COMBINATION MAST ARM ASSEMBLY AND POLE WITH LUMINAIRE AND FOUNDATION TO BE REMOVED			
TEMPORARY WOOD POLE (CLASS 5 OR BETTER) 45 FOOT (13.7m) MINIMUM				RELOCATE ITEM	RL			SIGNAL POST AND FOUNDATION TO BE REMOVED			
GUY WIRE				ABANDON ITEM	A			INTERSECTION & SAMPLING (SYSTEM) DETECTOR			
SIGNAL HEAD				12" (300mm) TRAFFIC SIGNAL SECTION				SAMPLING (SYSTEM) DETECTOR			
SIGNAL HEAD CONSTRUCTION STAGES (NUMBERS INDICATE THE CONSTRUCTION STAGE)				12" (300mm) RED WITH 8" (200mm) YELLOW AND GREEN TRAFFIC SIGNAL FACE				EXISTING INTERSECTION LOOP DETECTOR			
SIGNAL HEAD WITH BACKPLATE				SIGNAL FACE				PROPOSED INTERSECTION AND SAMPLING (SYSTEM) DETECTOR			
SIGNAL HEAD OPTICALLY PROGRAMMED				SIGNAL FACE WITH BACKPLATE, "P" INDICATES PROGRAMMED HEAD				EXISTING PREFORMED INTERSECTION LOOP DETECTOR			
FLASHER INSTALLATION (S DENOTES SOLAR POWER)				12" (300mm) PEDESTRIAN SIGNAL HEAD WALK/DON'T WALK SYMBOL				PROPOSED INTERSECTION AND SAMPLING (SYSTEM) DETECTOR			
PEDESTRIAN SIGNAL HEAD				12" (300mm) PEDESTRIAN SIGNAL HEAD INTERNATIONAL SYMBOL, OUTLINED				PREFORMED INTERSECTION AND SAMPLING (SYSTEM) DETECTOR			
PEDESTRIAN PUSHBUTTON DETECTOR				12" (300mm) PEDESTRIAN SIGNAL HEAD INTERNATIONAL SYMBOL, SOLID				PREFORMED SAMPLING (SYSTEM) DETECTOR			
ACCESSIBLE PEDESTRIAN PUSHBUTTON DETECTOR				PEDESTRIAN SIGNAL HEAD, INTERNATIONAL SYMBOL, WITH COUNTDOWN TIMER				RAILROAD SYMBOLS			
ILLUMINATED SIGN "NO LEFT TURN"				RADIO INTERCONNECT				RAILROAD CONTROL CABINET			
ILLUMINATED SIGN "NO RIGHT TURN"				RADIO REPEATER				RAILROAD CANTILEVER MAST ARM			
DETECTOR LOOP, TYPE I				DENOTES NUMBER OF CONDUCTORS, ELECTRIC CABLE NO. 14, UNLESS NOTED OTHERWISE, ALL DETECTOR LOOP CABLE TO BE SHIELDED				FLASHING SIGNAL			
PREFORMED DETECTOR LOOP				GROUND CABLE IN CONDUIT NO. 6 SOLID COPPER (GREEN)				CROSSING GATE			
MICROWAVE VEHICLE SENSOR								CROSSBUCK			
VIDEO DETECTION CAMERA											
VIDEO DETECTION ZONE											
PAN, TILT, ZOOM CAMERA											
WIRELESS DETECTOR SENSOR											
WIRELESS ACCESS POINT											

FILE NAME =	USER NAME = qureshiya	DESIGNED - DAG/BCK	REVISED -	STATE OF ILLINOIS DEPARTMENT OF TRANSPORTATION	DISTRICT ONE STANDARD TRAFFIC SIGNAL DESIGN DETAILS	F.A.P. RTE.	SECTION	COUNTY	TOTAL SHEETS	SHEET NO.	
ct:\pw\work\pvsdot\qureshiya\d212316\01s1std.dgn		DRAWN - BCK	REVISED -				2010-133-1	WILL	54	51	
PLOT SCALE = 50.6394' / IN.		CHECKED - DAD	REVISED -		SCALE: NONE	SHEET NO. 6 OF 6 SHEETS	STA.	TO STA.	CONTRACT NO. 60F75		
PLOT DATE = 10/26/2010		DATE - 10-28-09	REVISED -		FED. ROAD DIST. NO. 1 ILLINOIS FED. AID PROJECT						

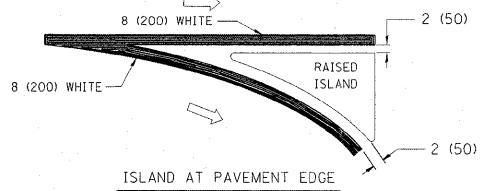
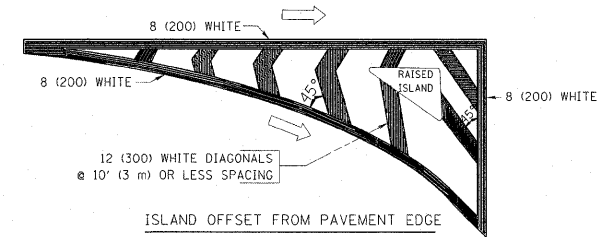
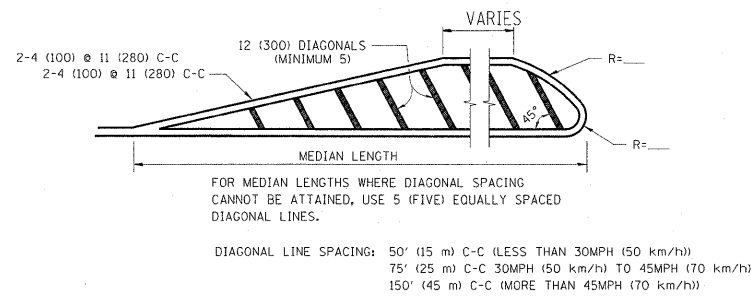
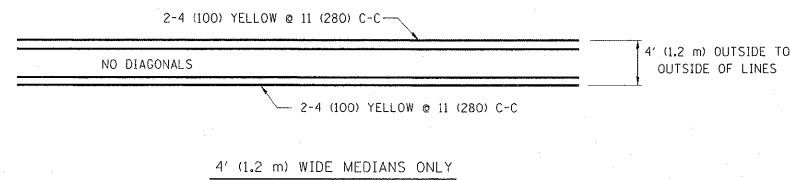
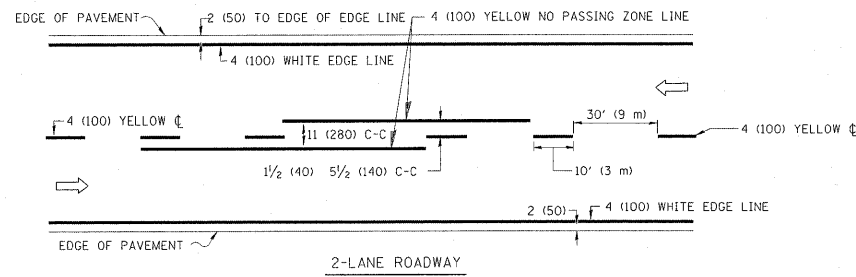

TYPICAL ISLAND MARKING

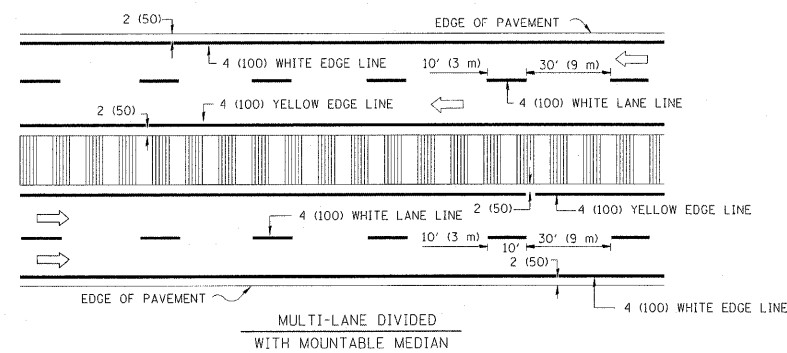
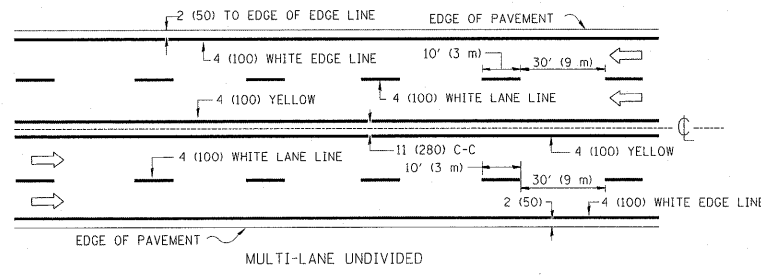

NOTE: MEDIANS WITH BARRIER CURB DO NOT REQUIRE AN EDGE LINE

TYPICAL LANE AND EDGE LINE MARKING

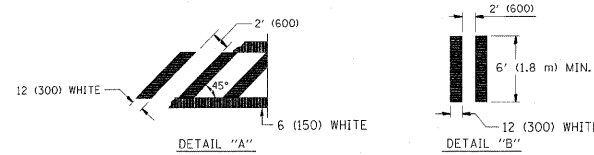
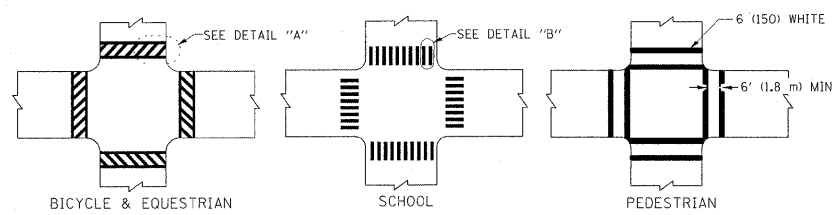

TYPICAL CROSSWALK MARKING

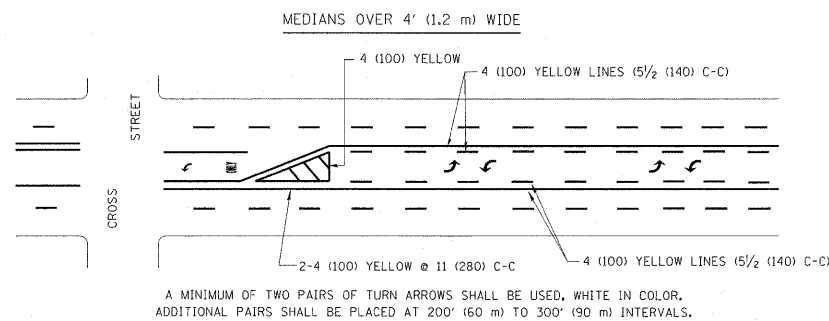

TYPICAL PAINTED MEDIAN MARKING

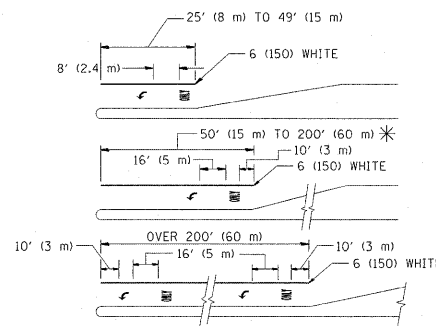

FULL SIZE LETTERS 8' (2.4 m) AND ARROWS SHALL BE USED.
* AREA = 15.6 SQ. FT. (1.5 m²) ONLY AREA = 20.8 SQ. FT. (1.9 m²)

* TURN LANES IN EXCESS OF 400' (120 m) IN LENGTH MAY HAVE AN ADDITIONAL SET OF ARROW - "ONLY" INSTALLED MIDWAY BETWEEN THE OTHER TWO SETS OF ARROW - "ONLY".

TYPICAL LEFT (OR RIGHT) TURN LANE

TYPICAL TURN LANE MARKING

TYPE OF MARKING	WIDTH OF LINE	PATTERN	COLOR	SPACING / REMARKS
CENTERLINE ON 2 LANE PAVEMENT	4 (100)	SKIP-DASH	YELLOW	10' (3 m) LINE WITH 30' (9 m) SPACE
CENTERLINE ON MULTI-LANE UNDIVIDED PAVEMENT	2 @ 4 (100)	SOLID	YELLOW	11 (280) C-C
NO PASSING ZONE LINES: FOR ONE DIRECTION FOR BOTH DIRECTIONS	4 (100) 2 @ 4 (100)	SOLID SOLID	YELLOW YELLOW	5/2 (140) C-C FROM SKIP-DASH CENTERLINE 11 (280) C-C OMIT SKIP-DASH CENTERLINE BETWEEN
LANE LINES	4 (100) 5 (125) ON FREEWAYS	SKIP-DASH SKIP-DASH	WHITE WHITE	10' (3 m) LINE WITH 30' (9 m) SPACE
DOTTED LINES (EXTENSIONS OF CENTER, LANE OR TURN LANE MARKINGS)	SAME AS LINE BEING EXTENDED	SKIP-DASH	SAME AS LINE BEING EXTENDED	2' (600) LINE WITH 6' (1.8 m) SPACE
EDGE LINES	4 (100)	SOLID	YELLOW-LEFT WHITE-RIGHT	OUTLINE MOUNTABLE MEDIANS IN YELLOW; EDGE LINES ARE NOT USED NEXT TO BARRIER CURB
TURN LANE MARKINGS	6 (150) LINE; FULL SIZE LETTERS & SYMBOLS (8' (2.4m))	SOLID	WHITE	SEE TYPICAL TURN LANE MARKING DETAIL
TWO WAY LEFT TURN MARKING	2 @ 4 (100) EACH DIRECTION 8' (2.4m) LEFT ARROW	SKIP-DASH AND SOLID IN PAIRS	YELLOW WHITE	10' (3 m) LINE WITH 30' (9 m) SPACE FOR SKIP-DASH; 5/2 (140) C-C BETWEEN SOLID LINE AND SKIP-DASH LINE SEE TYPICAL TWO-WAY LEFT TURN MARKING DETAIL
CROSSWALK LINES (PEDESTRIAN) A. DIAGONALS (BIKE & EQUESTRIAN) B. LONGITUDINAL BARS (SCHOOL)	2 @ 6 (150) 12 (300) @ 45° 12 (300) @ 90°	SOLID SOLID SOLID	WHITE WHITE WHITE	NOT LESS THAN 6' (1.8 m) APART 2' (600) APART 2' (600) APART SEE TYPICAL CROSSWALK MARKING DETAILS.
STOP LINES	24 (600)	SOLID	WHITE	PLACE 4' (1.2 m) IN ADVANCE OF AND PARALLEL TO CROSSWALK, IF PRESENT. OTHERWISE, PLACE AT DESIRED STOPPING POINT, PARALLEL TO CROSSROAD CENTERLINE, WHERE POSSIBLE
PAINTED MEDIANS	2 @ 4 (100) WITH 12 (300) DIAGONALS @ 45° NO DIAGONALS USED FOR 4' (1.2 m) WIDE MEDIANS	SOLID	YELLOW; TWO WAY TRAFFIC WHITE; ONE WAY TRAFFIC	11 (280) C-C FOR THE DOUBLE LINE SEE TYPICAL PAINTED MEDIAN MARKING.
GORE MARKING AND CHANNELIZING LINES	8 (200) WITH 12 (300) DIAGONALS @ 45°	SOLID	WHITE	DIAGONALS: 15' (4.5 m) C-C (LESS THAN 30MPH (50 km/h)) 20' (6 m) C-C 30MPH (50 km/h) TO 45MPH (70 km/h) 30' (9 m) C-C (OVER 45MPH (70 km/h))
RAILROAD CROSSING	24 (600) TRANSVERSE LINES; "RR" 15 6' (1.8 m) LETTERS; 16 (400) LINE FOR "X"	SOLID	WHITE	SEE STATE STANDARD 780001 AREA OF: "R"=3.6 SQ. FT. (0.33 m ²) EACH "X"=54.0 SQ. FT. (5.0 m ²)
SHOULDER DIAGONALS	12 (300) @ 45°	SOLID	WHITE - RIGHT YELLOW - LEFT	50' (15 m) C-C (LESS THAN 30MPH (50 km/h)) 75' (25 m) C-C (30 MPH (50 km/h) TO 45MPH (70 km/h)) 150' (45 m) C-C (OVER 45MPH (70 km/h))

FOR FURTHER DETAILS ON PAVEMENT MARKING REFER TO STANDARD SPECIFICATIONS FOR ROAD AND BRIDGE CONSTRUCTION AND STATE STANDARD 780001.

All dimensions are in inches (millimeters) unless otherwise shown.

FILE NAME =	USER NAME = qureshiya	DESIGNED - EVERS	REVISED - T. RAMMACHER 10-27-94
ct\pw_work\pawdot\qureshiya\d0212316\01s	Std.dgn	DRAWN -	REVISED - C. JUCIUS 09-09-09
	PLOT SCALE = 50:5394 1/4 IN.	CHECKED -	REVISED -
	PLOT DATE = 10/26/2010	DATE - 03-19-90	REVISED -

STATE OF ILLINOIS
DEPARTMENT OF TRANSPORTATION

DISTRICT ONE
TYPICAL PAVEMENT MARKINGS

SCALE: NONE SHEET NO. 1 OF 1 SHEETS STA. TO STA.

F.A.P. RTE.	SECTION	COUNTY	TOTAL SHEETS	SHEET NO.
	2010-133-1	WILL	54	52
	TC-13			CONTRACT NO. 60F75
FED. ROAD DIST. NO. 1 ILLINOIS FED. AID PROJECT				

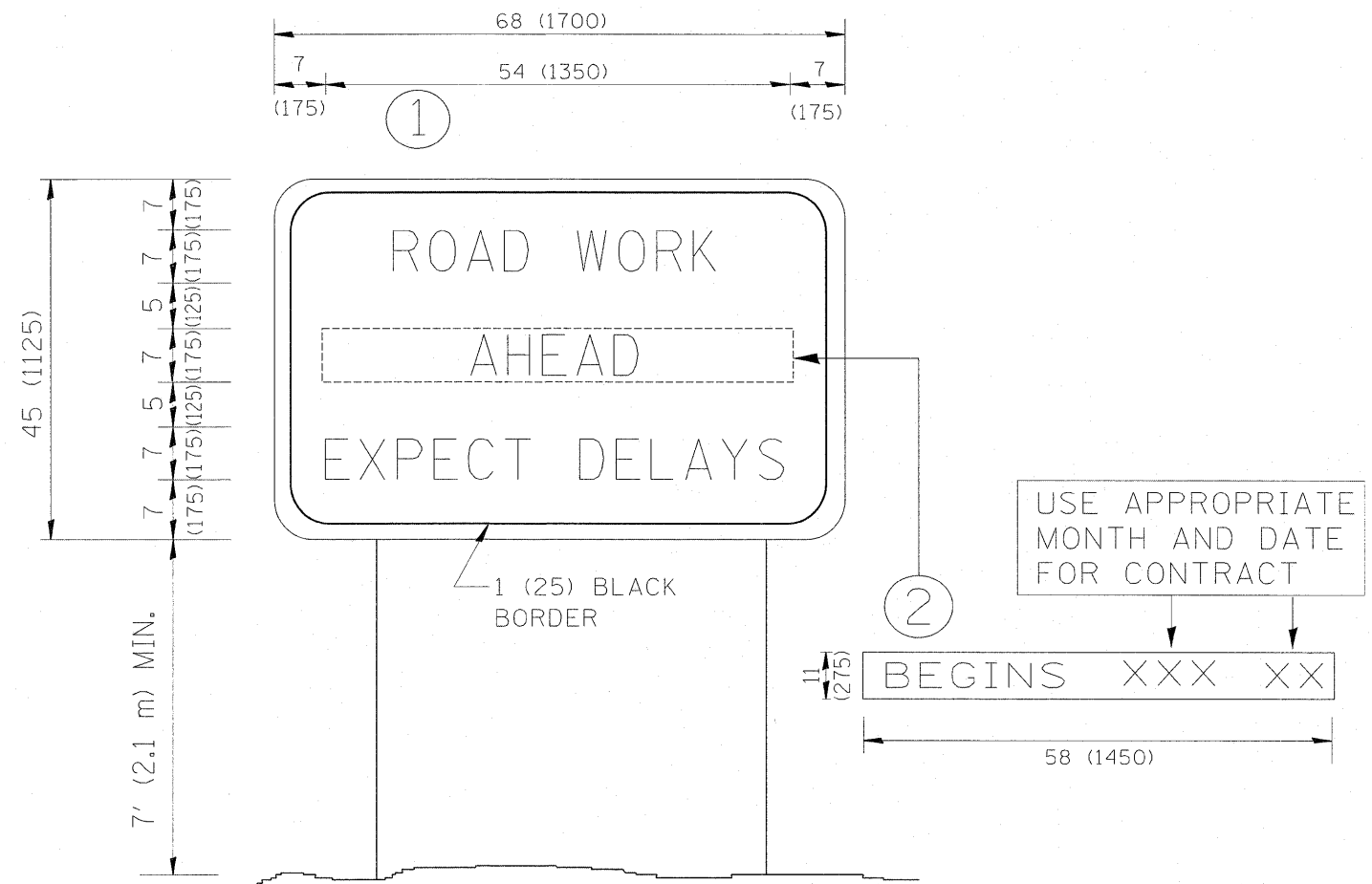

NOTES:

1. USE BLACK LETTERING ON ORANGE BACKGROUND.
2. ERECT SIGNS IN ADVANCE OF THE LOCATION FOR THE "ROAD CONSTRUCTION AHEAD" SIGN AT LOCATIONS AS DIRECTED BY THE ENGINEER.
3. ERECT SIGN ① WITH INSTALLED PANEL ② ONE WEEK PRIOR TO THE START OF CONSTRUCTION.
4. REMOVE PANEL ② SOON AFTER THE START OF CONSTRUCTION.
5. SEE SPECIAL PROVISION FOR "TEMPORARY INFORMATION SIGNING" FOR ADDITIONAL INFORMATION.
6. ONE SIGN ASSEMBLY EQUALS 25.70 SQ. FT. (2.3 SQ. M.)
7. SHALL BE PAID FOR AS TEMPORARY INFORMATION SIGNING.

ALL DIMENSIONS ARE IN INCHES (MILLIMETERS)
UNLESS OTHERWISE SHOWN.

FILE NAME =	USER NAME = qureshiya	DESIGNED -	REVISED - R. MIRS 09-15-97
ct:\pw_work\pwsdot\qureshiya\d0212316\Dis	Std.dgn	DRAWN -	REVISED - R. MIRS 12-11-97
	PLOT SCALE = 50.6394 "/ IN.	CHECKED -	REVISED - T. RAMMACHER 02-02-99
	PLOT DATE = 10/26/2010	DATE -	REVISED - C. JUCIUS 01-31-07

**STATE OF ILLINOIS
DEPARTMENT OF TRANSPORTATION**

**ARTERIAL ROAD
INFORMATION SIGN**

F.A.P. RTE.	SECTION	COUNTY	TOTAL SHEETS	SHEET NO.
•	2010-133-1	WILL	54	53
TC-22		CONTRACT NO. 60F75		
FED. ROAD DIST. NO. 1 ILLINOIS FED. AID PROJECT				

SCALE: NONE SHEET NO. 1 OF 1 SHEETS STA. TO STA.

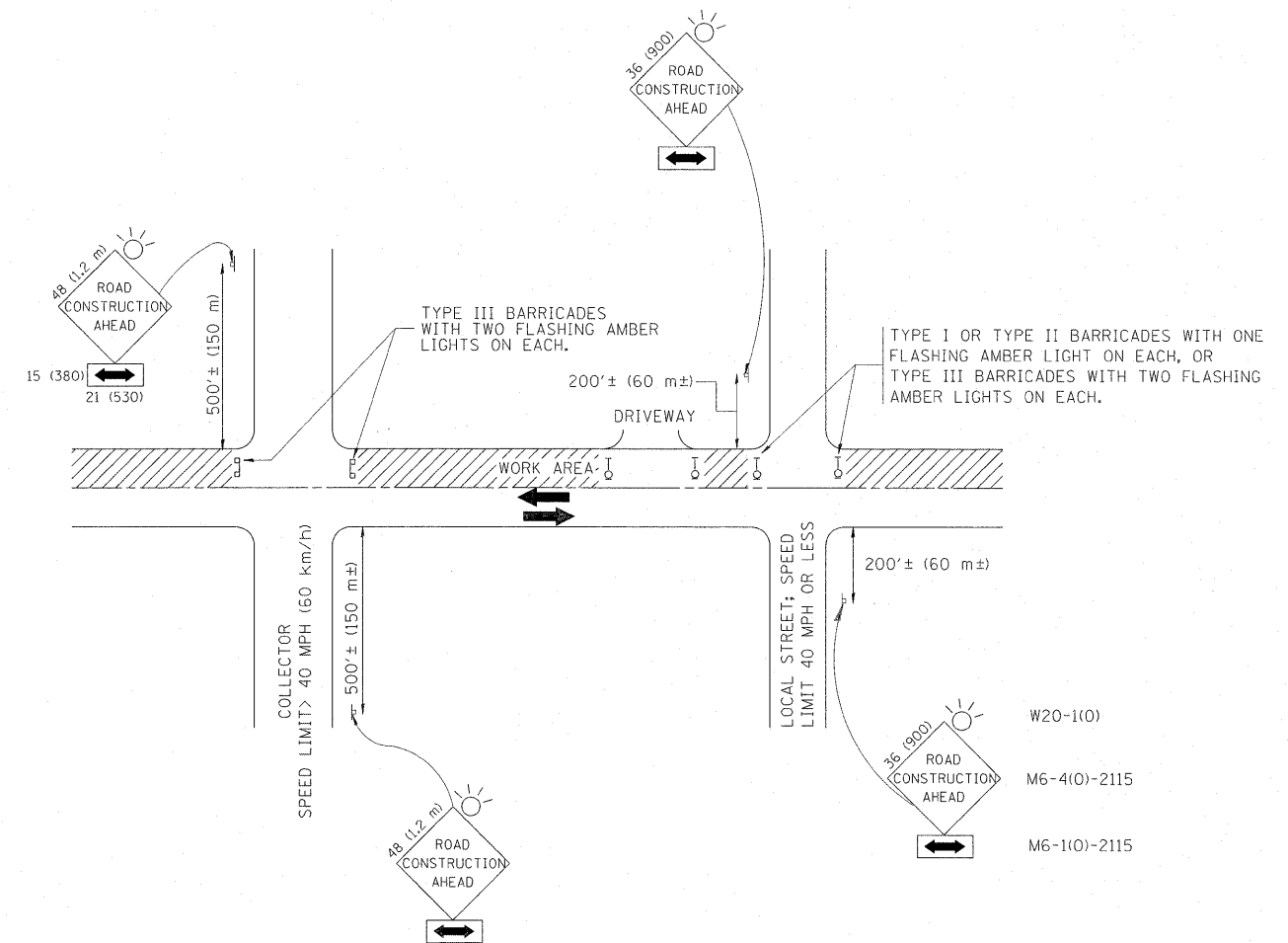

TRAFFIC CONTROL AND PROTECTION FOR SIDE ROADS, INTERSECTIONS, AND DRIVEWAYS

NOTES:

- A. FOR NO LANE RESTRICTION ON THE SIDE ROAD OR DRIVEWAYS
 1. SIDE ROAD WITH A SPEED LIMIT OF 40 MPH (60 km/h) OR LESS AS SHOWN ON THE DRAWING AND AS DIRECTED BY THE ENGINEER:
 - a) ONE ROAD CONSTRUCTION AHEAD SIGN 36 x 36 (900x900) WITH A FLASHER AND FLAG MOUNTED ON IT APPROXIMATELY 200' (60 m) IN ADVANCE OF THE MAIN ROUTE.
 - b) THE CLOSED PORTION OF THE MAIN ROUTE SHALL BE PROTECTED BY BLOCKING WITH TYPE I, TYPE II OR TYPE III BARRICADES, 1/3 OF THE CROSS SECTION OF THE CLOSED PORTION.
 2. SIDE ROAD WITH A SPEED LIMIT GREATER THAN 40 MPH (60 km/h) AS SHOWN ON THE DRAWING AND AS DIRECTED BY THE ENGINEER:
 - a) ONE ROAD CONSTRUCTION AHEAD SIGN 48 x 48 (1.2 m x 1.2 m) WITH A FLASHER MOUNTED ON IT APPROXIMATELY 500' (150 m) IN ADVANCE OF THE MAIN ROUTE.
 - b) THE CLOSED PORTION OF THE MAIN ROUTE SHALL BE PROTECTED BY BLOCKING WITH TYPE III BARRICADES, 1/2 OF THE CROSS SECTION OF THE CLOSED PORTION.
 3. WHEN THE SIDE ROAD LIES BETWEEN THE BEGINNING OF THE MAINLINE SIGNING AND THE WORK ZONE, A SINGLE HEADED ARROW (M6-1) SHALL BE USED IN LIEU OF THE DOUBLE HEADED ARROW (M6-4).
- B. FOR A LANE CLOSURE ON A SIDE ROAD OR DRIVEWAY:

USE APPLICABLE PORTIONS OF THE TYPICAL APPLICATION OF TRAFFIC CONTROL DEVICES (STD. 701501, STD. 701606 OR THE APPROPRIATE STANDARD). THE SPACING OF SIGNS AND BARRICADES SHALL BE ADJUSTED FOR FIELD CONDITIONS AS DIRECTED BY THE ENGINEER. THE DIRECTIONAL ARROW SHALL BE COVERED OR REMOVED WHEN NO LONGER CONSISTENT WITH THE SIDE ROAD LANE CLOSURE.
- C. ADVANCE WARNING SIGNS ARE TO BE OMITTED ON DRIVEWAY UNLESS OTHERWISE NOTED.
- D. THE TRAFFIC CONTROL AND PROTECTION FOR SIDE ROADS, INTERSECTIONS, AND DRIVEWAYS SHALL BE INCIDENTAL TO THE COST OF SPECIFIED TRAFFIC CONTROL STANDARDS OR ITEMS.

All dimensions are in millimeters (inches) unless otherwise shown.

FILE NAME =	USER NAME = qureshiya	DESIGNED - LHA	REVISED - J. OBERLE 10-18-95
c:\pwork\pwork\qureshiya\d212316\Dis	std.dgn	DRAWN -	REVISED - A. HOUSEH 03-06-96
PLOT SCALE = 50.0000" / IN.	CHECKED -	REVISED - A. HOUSEH 10-15-96	
PLOT DATE = 10/26/2010	DATE - 06-89	REVISED - T. RAMMACHER 01-06-00	

STATE OF ILLINOIS
DEPARTMENT OF TRANSPORTATION

TRAFFIC CONTROL AND PROTECTION FOR
SIDE ROADS, INTERSECTIONS, AND DRIVEWAYS

SCALE: NONE SHEET NO. 1 OF 1 SHEETS STA. TO STA.

F.A.P. RTE.	SECTION	COUNTY	TOTAL SHEETS	SHEET NO.
	2010-133-1	WILL	54	53A
TC-10			CONTRACT NO. 60F75	
FED. ROAD DIST. NO. 1 ILLINOIS FED. AID PROJECT				

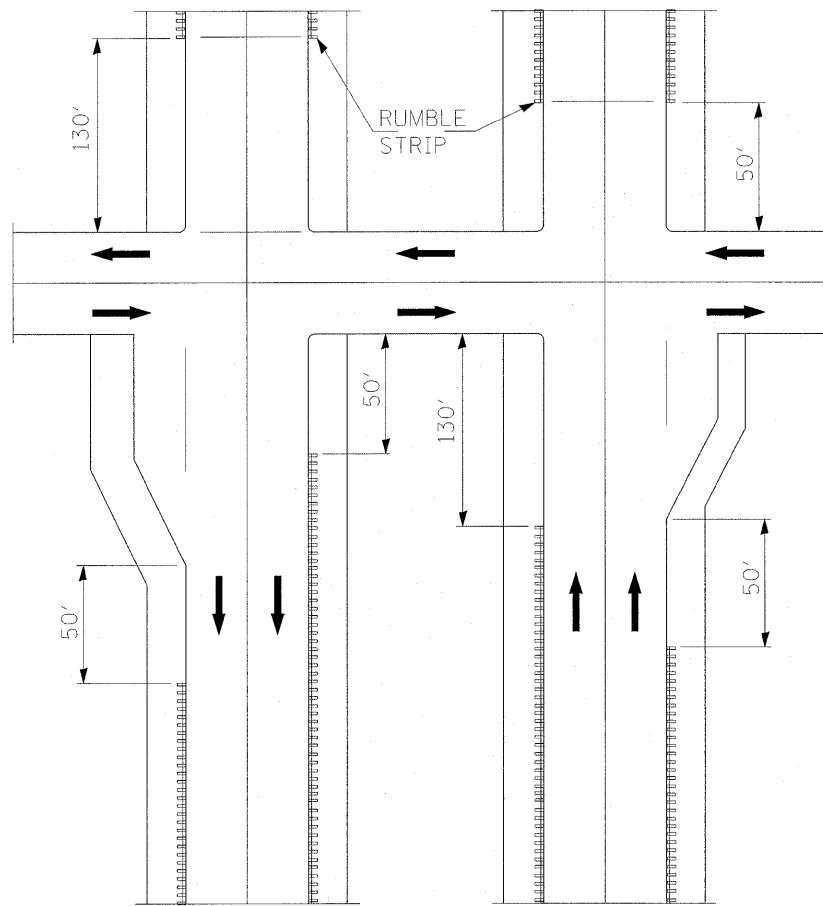

RUMBLE STRIPE EXPRESSWAY DIVIDED

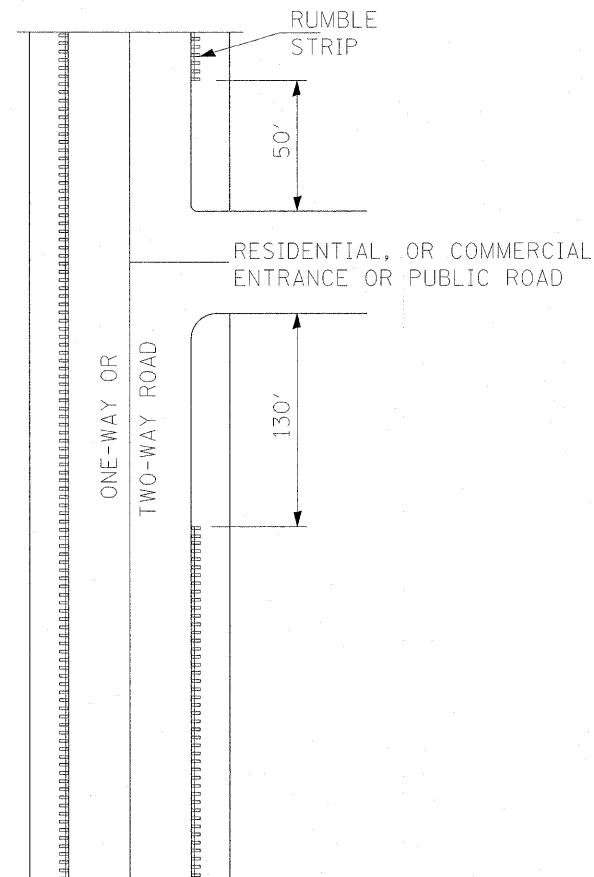

RUMBLE STRIPE INTERSECTIONS

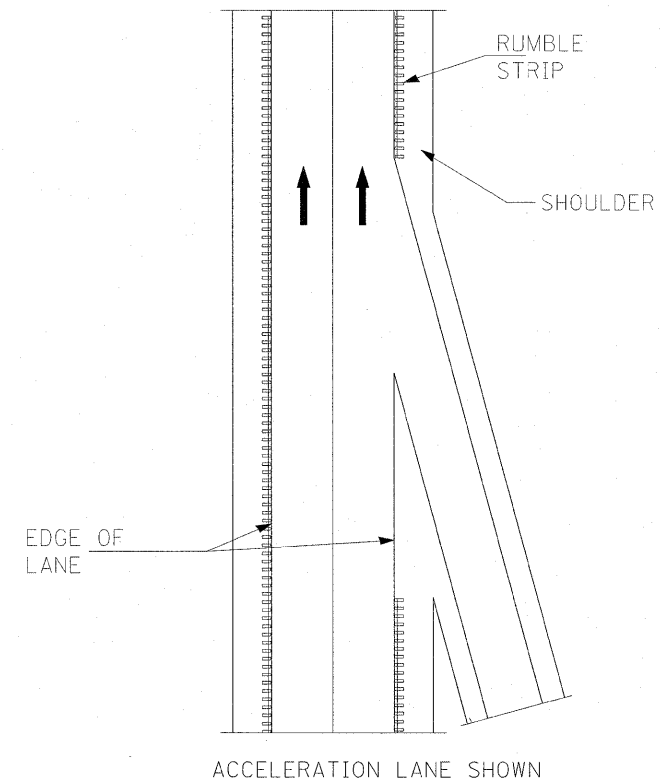

RUMBLE STRIPE ACCELERATION OR DECELERATION LANE

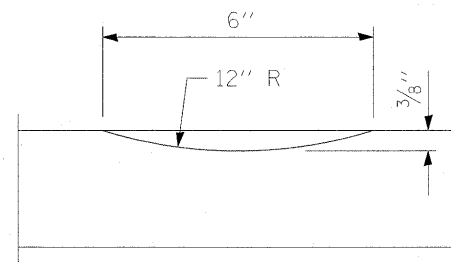

SECTION A-A

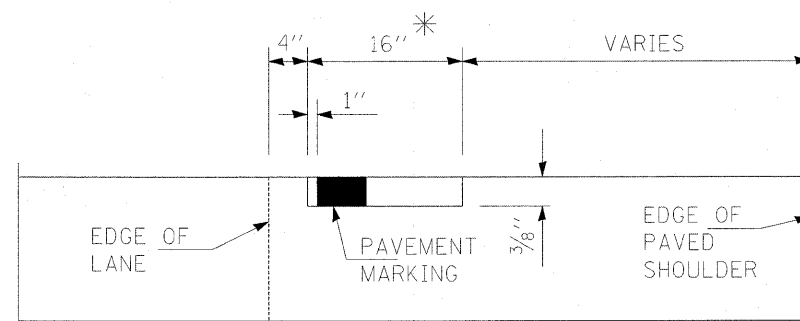

SECTION B-B

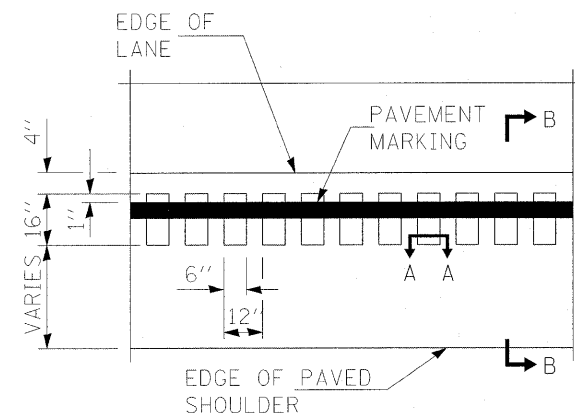

PLAN FOR RUMBLE STRIPE

GENERAL NOTES

ON PORTLAND CEMENT CONCRETE SHOULDERS, NO SHOULDER RUMBLE STRIPE SHALL BE LOCATED CLOSER THAN 150 mm (6") TO A TRANSVERSE JOINT.

OMIT SHOULDER RUMBLE STRIPE ACROSS STRUCTURES.

SHOULDER RUMBLE STRIPES TO BE PAID FOR AS SHOULDER RUMBLE STRIPE AND THERMOPLASTIC PAVEMENT MARKING - LINE 4"

* 8" WIDE RUMBLE STRIPES TO BE INSTALLED AT LOCATIONS ADJACENT TO GUARDRAIL W. HMA SHOULDERS < 3'

FILE NAME =	USER NAME = qureshiya	DESIGNED -	REVISED -
c:\pwork\pavidot\qureshiya\d0212316\0123609-sht-plan.dgn		DRAWN -	REVISED -
		CHECKED -	REVISED -
		DATE -	REVISED -

STATE OF ILLINOIS
DEPARTMENT OF TRANSPORTATION

SHOULDER RUMBLE STRIPE FOR NON-FREEWAY

SCALE: SHEET NO. OF SHEETS STA. TO STA.

F.A.P. RTE.	SECTION	COUNTY	TOTAL SHEETS	SHEET NO.
*	2010-133-1	WILL	54	54
* 846/357			CONTRACT NO. 60F75	
ILLINOIS FED. AID PROJECT				