

SECTION B-B

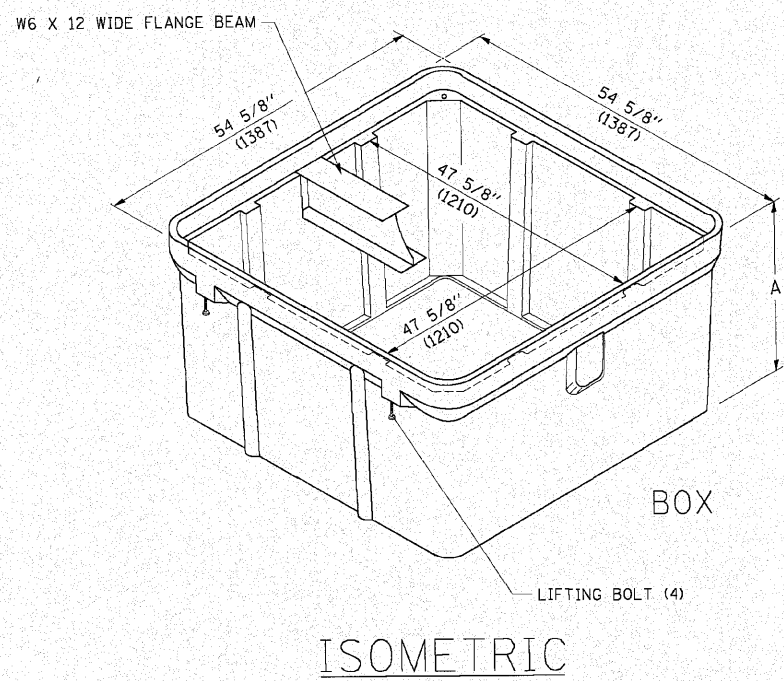

ISOMETRIC

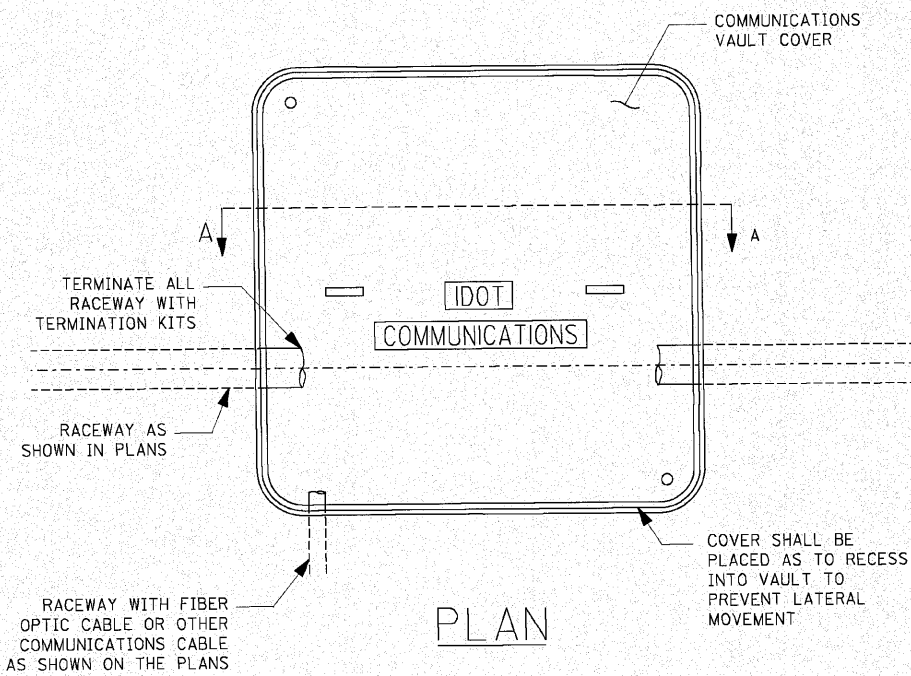

PLAN

NOTES:

1. BOX SHALL HAVE AN OPEN BASE.
2. COVER SHALL WITHSTAND A 22,500/33,750 DESIGN/TEST LOADING AND SHALL LOCK.
3. ALL OPENINGS IN STRUCTURE MUST BE MACHINED AT TIME OF FABRICATION OR PUNCH DRIVEN AT TIME OF PLACEMENT. IN ACCORDANCE WITH MANUFACTURER RECOMMENDATIONS.
4. FIELD PLACEMENT OF COMMUNICATIONS VAULT SHALL BE AS DIRECTED BY THE ENGINEER.
5. ALL DIMENSIONS ARE MINIMUM AND A LARGER SIZE HANDHOLE MAY BE USED, WITH THE APPROVAL OF THE ENGINEER, TO FACILITATE USING A MANUFACTURER'S STANDARD PRODUCT.

	USER NAME - 10450	DESIGNED -	REVISED -	STATE OF ILLINOIS DEPARTMENT OF TRANSPORTATION	COMMUNICATIONS VAULT, COMPOSITE CONCRETE			F.A. I. RTE.	SECTION	COUNTY	TOTAL SHEETS	SHEET NO.
	PLLOT SCALE = 5/8" = 1' / IN.	CHECKED -	REVISED -					80	99-5-Y	WILL	277	175
PLLOT DATE = 3/29/2010	DATE = 03-22-10	REVISED -	REVISED -	SCALE: NONE	SHEET NO.	OF	SHEETS	STA.	TO STA.	BE-705 CONTRACT NO. 60147 FED. ROAD DIST. NO. 1 ILLINOIS FED. AID PROJECT		