

DATE: _____
 BY: _____
 SURVEYED: _____
 ALIGNED: _____
 CHECKED: _____
 FT. OF WAY CHECKED: _____
 NOTE BOOK NO.: _____
 PLAN NO.: _____

DATE: _____
 BY: _____
 SURVEYED: _____
 GRADES CHECKED: _____
 NOTE BOOK NO.: _____
 PROFILE NO.: _____

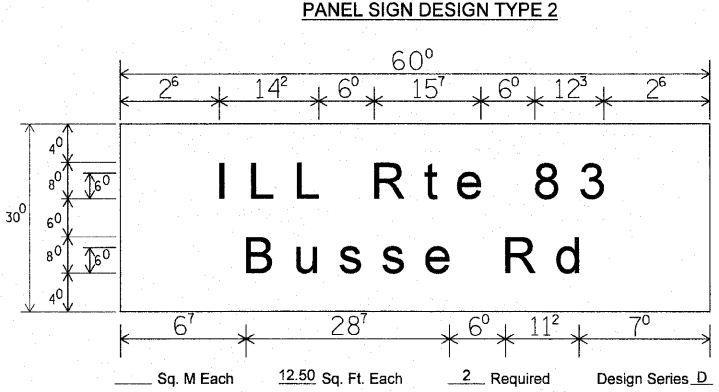
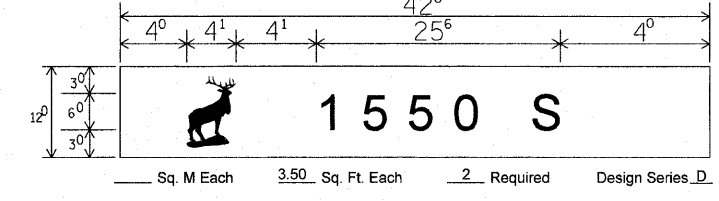
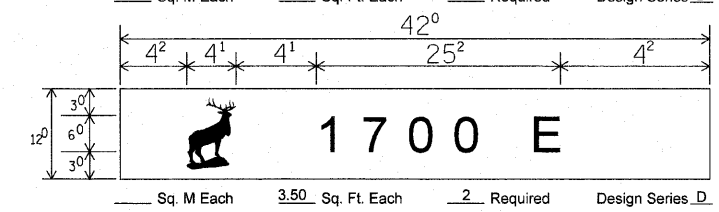
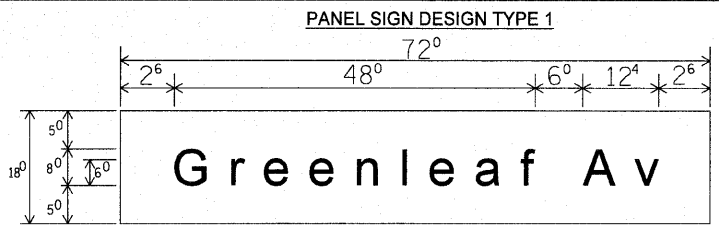

NOTE: SIGN DIMENSIONS ARE IN ENGLISH UNITS.

GENERAL NOTES

- WHERE MAST ARM MOUNTED STREET SIGNS ARE SPECIFIED, THE MAST ARM ASSEMBLY AND POLES SHALL BE DESIGNED TO SUPPORT THE LOADINGS CALLED FOR ON STANDARDS 8877001, 877002, 877006, 877011, 877012, AS APPLICABLE. PLUS TWO (2) SIGN PANELS 2'-6" X 8'-0" MOUNTED AS SHOWN. THE DESIGN SHALL BE IN ACCORDANCE WITH THE REQUIREMENTS OF THE CURRENT "STANDARD SPECIFICATIONS FOR THE STRUCTURAL SUPPORTS FOR HIGHWAY SIGNS, LUMINAIRES, AND TRAFFIC SIGNALS" AS PUBLISHED BY THE AMERICAN ASSOCIATION OF STATE HIGHWAY AND TRANSPORTATION OFFICIALS FOR 80 M.P.H. WIND VELOCITIES.
- ALL SIGNS SHALL HAVE A WHITE REFLECTORIZED LEGEND AND BORDER ON A GREEN REFLECTORIZED BACKGROUND, TYPE A SHEETING.
- THE SIGN LENGTH SHOULD BE INCREASED IN 6-INCH INCREMENTS, BUT THE OVERALL LENGTH SHALL NOT EXCEED 8'0".
- ALL BORDERS SHALL BE 3/4" WIDE AND CORNER RADIUS SHALL BE 2-1/4".
- SIGNFIX ALUMINUM CHANNEL FRAMING SYSTEM SHALL BE USED FOR ALL SIGNS ATTACHED TO SIGNAL POLES AND POSTS. LOCAL SUPPLIERS OF THE SIGNFIX ALUMINUM CHANNEL FRAMING SYSTEM ARE:

* J.O. HERBERT CO. MIDLOTHIAN, VA * WESTERN REMAC INC. WOODRIDGE, IL

- PARTS LISTING:
- SIGN CHANNEL PART #HPN053 (MED. CHANNEL)
 - SIGN SCREWS 1/4" x 14 x 1" H.W.H #3
 - BRACKETS PART #HPN034 (UNIVERSAL)
 - CHANNEL CLAMPS WITH STAINLESS STEEL STRAPPING

OTHER BRANDS OF MOUNTING HARDWARE ARE ACCEPTABLE, BASED UPON THE DEPARTMENT'S APPROVAL AND COMPATIBILITY WITH THE CHANNEL/BACKET OF THE ABOVE PRODUCT.

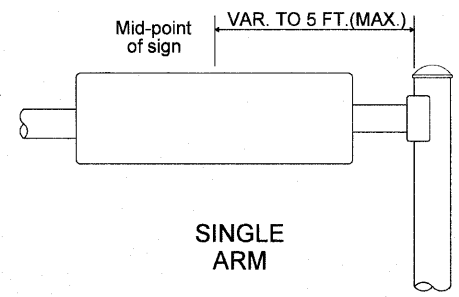
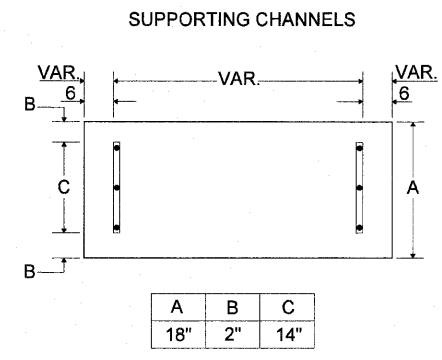

SIGNFIX ALUMINUM CHANNEL FRAMING SYSTEM shall be used. See Note #5.

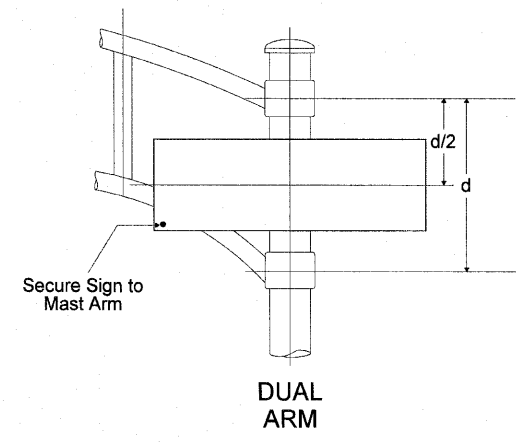
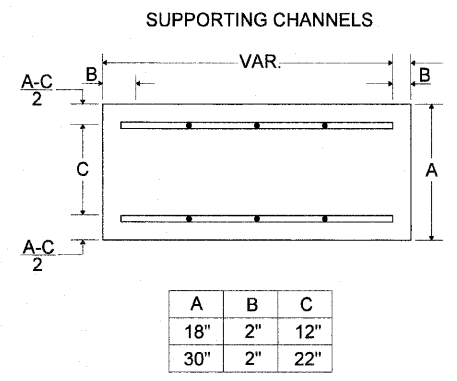

UPPER TO LOWER CASE SPACING CHART 8-6 INCH SERIES "C" & "D"

EXAMPLE, 2³ DENOTES 3/8"

SERIES	SECOND LETTER															
	a c c d e		b h i k		f w		j		s t		v y		x		z	
	g o q	l m n p r u														
A W X	1 ²	1 ⁴	1 ⁴	1 ⁵	1 ²	1 ⁴	0 ⁶	1 ⁰	1 ¹	1 ⁴	0 ⁶	1 ⁰	1 ¹	1 ²	1 ²	1 ⁴
B	1 ⁴	1 ⁵	2 ⁰	2 ¹	1 ⁴	1 ⁵	1 ¹	1 ²	1 ⁴	1 ⁵	1 ²	1 ⁴	1 ²	1 ⁴	1 ⁶	1 ⁷
C E G	1 ⁴	1 ⁵	2 ⁰	2 ¹	1 ²	1 ⁴	0 ⁶	1 ⁰	1 ²	1 ⁴	1 ²	1 ⁴	1 ⁴	1 ⁵	1 ⁴	1 ⁵
D O Q R	1 ⁴	1 ⁵	2 ⁰	2 ¹	1 ⁴	1 ⁵	0 ⁶	1 ⁰	1 ²	1 ⁴	1 ²	1 ⁴	1 ⁴	1 ⁵	1 ⁴	1 ⁵
F	0 ⁵	0 ⁶	1 ⁴	1 ⁵	0 ⁶	1 ⁰	0 ⁵	0 ⁶	0 ⁶	1 ⁰	0 ⁶	1 ⁰	0 ⁶	1 ⁰	1 ¹	1 ²
H I M N	2 ⁰	2 ¹	2 ²	2 ⁴	2 ⁰	2 ¹	1 ⁴	1 ⁵	1 ⁶	1 ⁷	1 ⁶	1 ⁷	2 ⁰	2 ¹	2 ⁰	2 ¹
J U	2 ⁰	2 ¹	2 ⁰	2 ¹	1 ⁶	1 ⁷	1 ⁴	1 ⁵	1 ⁶	1 ⁷	1 ⁶	1 ⁷	1 ⁶	1 ⁷	2 ⁰	2 ¹
K L	1 ¹	1 ²	1 ⁶	1 ⁷	1 ¹	1 ²	0 ⁵	0 ⁶	1 ¹	1 ²	1 ¹	1 ²	1 ¹	1 ²	1 ²	1 ⁴
P	1 ²	1 ⁴	1 ⁴	1 ⁵	1 ²	1 ⁴	0 ⁵	0 ⁶	1 ¹	1 ²	1 ¹	1 ²	1 ²	1 ⁴	1 ²	1 ⁴
S	1 ²	1 ⁴	1 ⁶	1 ⁷	1 ²	1 ⁴	0 ⁶	1 ⁰	1 ²	1 ⁴	1 ²	1 ⁴	1 ²	1 ⁴	1 ²	1 ⁴
T	1 ¹	1 ²	1 ⁶	1 ⁷	0 ⁶	1 ⁰	0 ⁶	1 ⁰	1 ¹	1 ²	1 ¹	1 ²	1 ¹	1 ²	1 ²	1 ⁴
V	0 ⁶	1 ⁰	1 ⁴	1 ⁵	1 ¹	1 ²	0 ⁶	1 ⁰	1 ²	1 ⁴	1 ²	1 ⁴	1 ²	1 ⁴	1 ²	1 ⁴
Y	0 ⁵	0 ⁶	1 ⁴	1 ⁵	0 ⁶	1 ⁰	0 ⁵	0 ⁶	0 ⁵	0 ⁷	0 ⁵	0 ⁶	0 ⁶	1 ⁰	1 ¹	1 ²
Z	1 ⁶	1 ⁷	2 ²	2 ⁴	1 ⁶	1 ⁷	1 ²	1 ⁴	1 ⁶	1 ⁷	1 ⁶	1 ⁷	1 ⁶	1 ⁷	2 ⁰	2 ¹

LOWER CASE TO LOWER CASE SPACING CHART 6 INCH SERIES "C" & "D"

SERIES	SECOND LETTER															
	a c c d e		b h i k		f w		j		s t		v y		x		z	
	g o q	l m n p r u														
F																
I																
R																
S																
T																
L																
E																
T																
E																
R																

NUMBER TO NUMBER SPACING CHART 8 INCH SERIES "C" & "D"

SERIES	SECOND NUMBER																				
	0		1		2		3		4		5		6		7		8		9		
F																					
I																					
R																					
S																					
T																					
L																					
E																					
T																					
E																					
R																					

UPPER AND LOWER CASE LETTER WIDTHS

LETTERS	6 INCH UPPER CASE LETTERS				8 INCH UPPER CASE LETTERS				6 INCH LOWER CASE LETTERS			
	SERIES		SERIES		SERIES		SERIES		SERIES		SERIES	
	C	D	C	D	C	D	C	D	C	D	C	D
A	3 ⁶	5 ⁰	5 ⁰	6 ⁵	a	3 ⁵	4 ²					
B	3 ²	4 ⁰	4 ³	5 ³	b	3 ⁵	4 ²					
C	3 ²	4 ⁰	4 ³	5 ³	c	3 ⁵	4 ¹					
D	3 ²	4 ⁰	4 ³	5 ³	d	3 ⁵	4 ²					
E	3 ⁰	3 ⁵	4 ⁰	4 ⁷	e	3 ⁵	4 ²					
F	3 ⁰	3 ⁵	4 ⁰	4 ⁷	f	2 ³	2 ⁶					
G	3 ²	4 ⁰	4 ³	5 ³	g	3 ⁵	4 ²					
H	3 ²	4 ⁰	4 ³	5 ³	h	3 ⁵	4 ²					
I	0 ⁷	0 ⁷	1 ¹	1 ²	i	1 ¹	1 ¹					
J	3 ⁰	3 ⁶	4 ⁰	5 ⁰	j	2 ⁰	2 ²					
K	3 ²	4 ¹	4 ³	5 ⁴	k	3 ⁵	4 ²					
L	3 ⁰	3 ⁵	4 ⁰	4 ⁷	l	1 ¹	1 ¹					
M	3 ⁷	4 ⁵	5 ¹	6 ¹	m	6 ⁰	7 ⁰					
N	3 ²	4 ⁰	4 ³	5 ³	n	3 ⁵	4 ²					
O	3 ⁴	4 ²	4 ⁵	5 ⁵	o	3 ⁶	4 ³					
P	3 ²	4 ⁰	4 ³	5 ³	p	3 ⁵	4 ²					
Q	3 ⁴	4 ²	4 ⁵	5 ⁵	q	3 ⁵	4 ²					
R	3 ²	4 ⁰	4 ³	5 ³	r	2 ⁶	3 ²					
S	3 ²	4 ⁰	4 ³	5 ³	s	3 ⁶	4 ²					
T	3 ⁰	3 ⁵	4 ⁰	4 ⁷	t	2 ⁷	3 ²					
U	3 ²	4 ⁰	4 ³	5 ³	u	3 ⁵	4 ²					
V	3 ⁵	4 ⁴	4 ⁷	6 ⁰	v	4 ²	4 ⁷					
W	4 ⁴	5 ²	6 ⁰	7 ⁰	w	5 ⁵	6 ⁴					
X	3 ⁴	4 ⁰	4 ⁵	5 ³	x	4 ⁴	5 ¹					
Y	3 ⁶	5 ⁰	5 ⁰	6 ⁶	y	4 ⁶	5 ³					
Z	3 ²	4 ⁰	4 ³	5 ³	z	3 ⁶	4 ³					

NUMBER	6 INCH SERIES		8 INCH SERIES	
	C	D	C	D
1	1 ²	1 ⁴	1 ⁵	2 ⁰
2	3 ²	4 ⁰	4 ³	5 ³
3	3 ²	4 ⁰	4 ³	5 ³
4	3 ⁵	4 ⁰	4 ⁷	5 ⁷
5	3 ²	4 ⁰	4 ³	5 ³
6	3 ²	4 ⁰	4 ³	5 ³
7	3 ²	4 ⁰	4 ³	5 ³
8	3 ²	4 ⁰	4 ³	5 ³
9	3 ²	4 ⁰	4 ³	5 ³
0	3 ⁴	4 ²	4 ⁵	5 ⁵