

STATE OF ILLINOIS
DEPARTMENT OF TRANSPORTATION

ROUTE NO.	DISTRICT	COUNTY	SECTION	SHEET NO.
F.A.P. 704	CDT	MCLEAN	497	205
PROJECT NO.	DATE	DESIGNED BY	CHECKED BY	DRAWN BY

CONTRACT NO. 70514

BILL OF MATERIAL

Bar	No.	Size	Length	Shape
d(E)	668	#16	0.910m	┌
d ₁ (E)	334	#16	1.030m	┌
d ₂ (E)	334	#16	0.990m	┌
e(E)	56	#16	9.050m	—
e ₁ (E)	14	#25	9.730m	—
e ₂ (E)	32	#16	8.330m	—
e ₃ (E)	8	#25	8.330m	—
h(E)	14	#16	9.050m	—
h ₁ (E)	117	#16	9.050m	—
h ₂ (E)	68	#16	8.330m	—
h ₃ (E)	8	#16	8.330m	—
h ₄ (E)	8	#16	0.790m	—
n(E)	134	#22	1.890m	┌
n ₁ (E)	269	#25	2.750m	┌
n ₂ (E)	45	#16	1.270m	┌
t(E)	122	#16	2.98m	—
t ₁ (E)	524	#16	3.43m	—
t ₂ (E)	63	#16	3.00m	—
t ₃ (E)	60	#16	2.50m	—
v(E)	15	#16	2.780m	—
v ₁ (E)	89	#16	2.340m	—
v ₂ (E)	15	#16	3.240m	—
v ₃ (E)	269	#22	2.560m	—
v ₄ (E)	30	#16	3.210m	—
v ₅ (E)	7	#16	3.290m	—
v ₆ (E)	8	#16	2.820m	—
v ₇ (E)	45	#16	2.370m	—
v ₈ (E)	53	#16	2.320m	—
w(E)	32	#16	8.690m	—
w ₁ (E)	126	#16	8.950m	—
w ₂ (E)	30	#16	8.330m	—
z(E)	23	#16	1.860m	┌
z ₁ (E)	23	#16	1.990m	┌
Concrete Structures		m ³	259	
Reinforcement Bars, Epoxy Coated		kg	20,350	

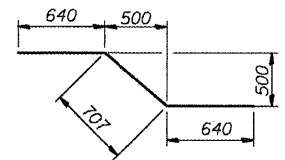
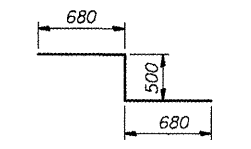
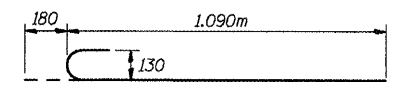
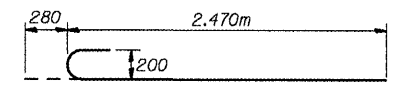
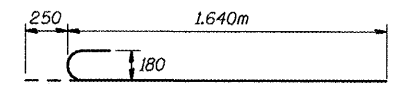
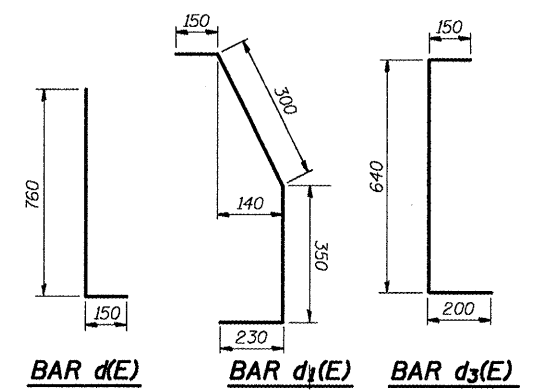
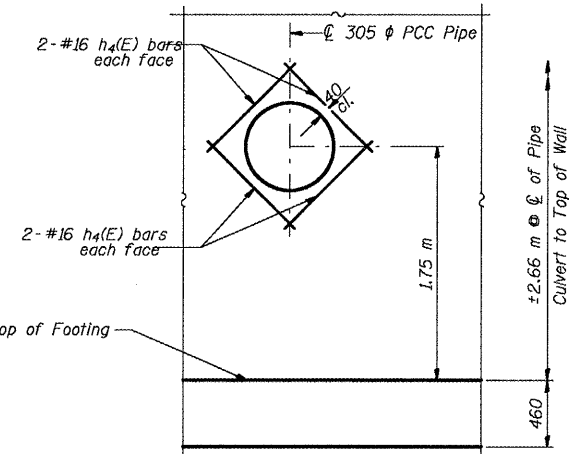
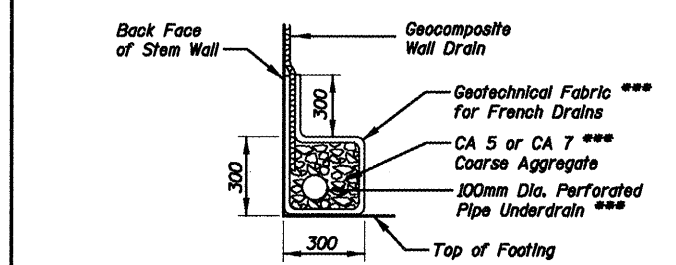
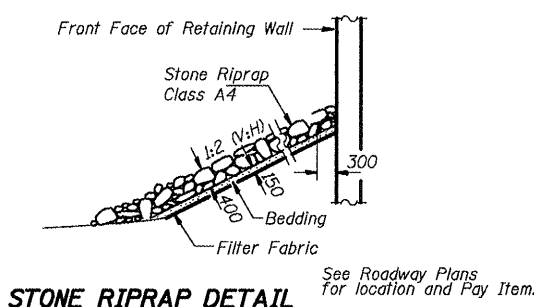
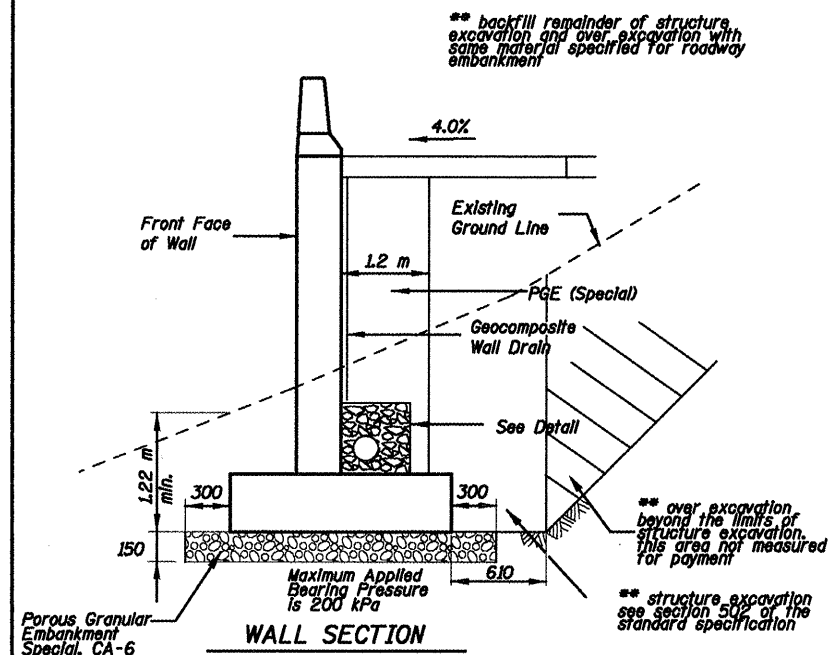

MIN. BAR LAP

#16	640mm
#25	1.320m

Bars indicated thus 12 x 4-#15 etc. indicates 12 lines of bars with 4 lengths per line.

Reinforcement bars designated (E) shall be epoxy coated. All construction joints shall be bonded.

DETAILS
RETAINING WALL ALONG
W.B.L. VETERANS PARKWAY
F.A.P. ROUTE 704 SECTION (D) N&TS-1
MCLEAN COUNTY
STATION 2+785.000 TO 2+877.000
STRUCTURE NO. 057-W002

SHIVE-HATTERY

DESIGNED	Jda
CHECKED	WCT
DRAWN	mac
CHECKED	WCT

DATE: 06-25-10