

F.A.P. RTE.	SECTION	COUNTY	TOTAL SHEETS	SHEET NO.
704	(1)N&TS-1	McLEAN	497	302
STA. N/A		TO STA. N/A		
FED. ROAD DIST. NO.		ILLINOIS	FED. AID PROJECT	
CONTRACT NO. 70514				

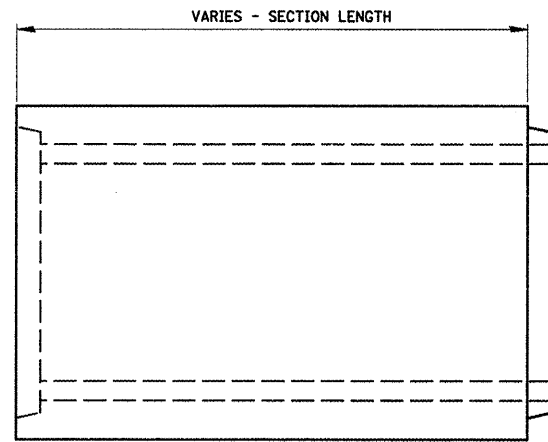

ELEVATION

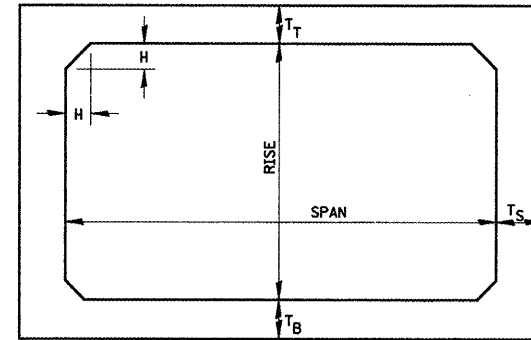

NOTE: THE HAUNCH DIMENSION H, IS EQUAL TO THE WALL THICKNESS T_S.

TYPICAL BOX SECTION

SPAN, METERS	T _T , mm		T _B , mm		T _S , mm	
	M 259	M 273	M 259	M 273	M 259	M 273
.915	100	180	100	150	100	100
1.220	125	190	125	150	125	125
1.525	150	205	150	180	150	150
1.830	180	205	180	180	180	180
2.135	205	205	205	205	205	205
2.435	205	205	205	205	205	205
2.740	230	230	230	230	230	230
3.045	255	255	255	255	255	255
3.350	280	280	280	280	280	280
3.650	305	305	305	305	305	305

TYPICAL THICKNESSES

GENERAL NOTES:

MINIMUM COVER FOR BOX CULVERTS SHALL BE 150mm.

PRECAST CONCRETE BOX SECTION

(EXTENSION OF 900X600 RCBC @ GREENWOOD AVE. STA. 10+685.810, 5.409 m RT.)

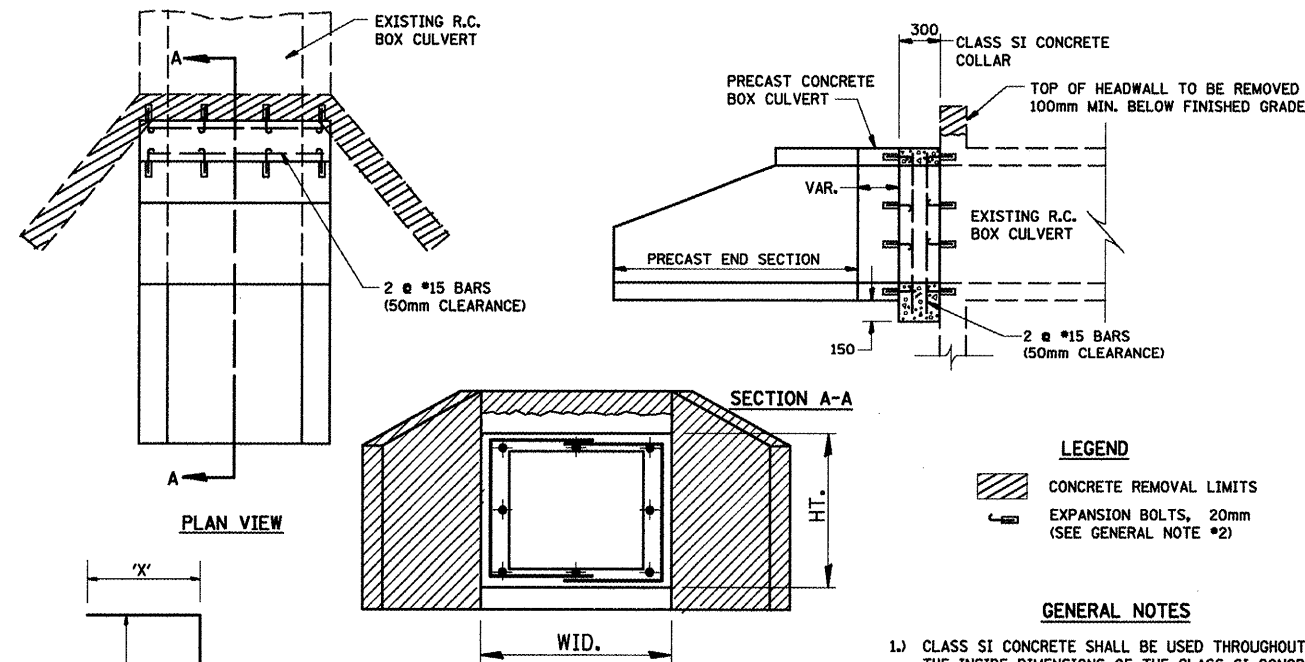

LEGEND

- CONCRETE REMOVAL LIMITS
- EXPANSION BOLTS, 20mm (SEE GENERAL NOTE #2)

GENERAL NOTES

- 1.) CLASS SI CONCRETE SHALL BE USED THROUGHOUT. THE INSIDE DIMENSIONS OF THE CLASS SI CONCRETE COLLAR SHALL BE THE SAME AS THE NEW PRECAST CONCRETE BOX CULVERT.
- 2.) EXPANSION BOLTS SHALL CONSIST OF SELF DRILLING EXPANSION SHIELDS AND 20mm HOOKED BOLTS. HOOKED BOLTS SHALL EXTEND A MINIMUM OF 225mm INTO NEW CONCRETE. BOLTS SHALL BE PLACED IN EACH CORNER AND AT 450mm MAXIMUM CENTERS. MINIMUM CERTIFIED PROOF LOADING = 18.1 kN.

ALL DIMENSIONS ARE IN MILLIMETERS UNLESS OTHERWISE SHOWN.

LOCATION	EXISTING CULVERT SIZE	PRECAST CULV. EXTENSION	U-BAR		CONC. COLLAR	REINFORCEMENT BARS	20mm DIA. EXPANSION BOLTS
			x'	y'			
10+685.81	900x600	600	775	800	0.7	14.6	8

MIN. LAP FOR #15 BAR IS 450 mm

COLLAR DETAIL (PRECAST BOX CULVERT EXTENSION OF BOX CULVERT)
(EXTENSION OF 900X600 RCBC @ GREENWOOD AVE. STA. 10+685.810, 5.409 m RT.)

540-6

REVISIONS	
NAME	DATE

ILLINOIS DEPARTMENT OF TRANSPORTATION

DISTRICT DETAILS

DRAWN BY SAM
CHECKED BY PMH

DATE 05-27-09