

F.A.P. RTE.	SECTION	COUNTY	TOTAL SHEETS	SHEET NO.
704	(1)N&TS-1	McLEAN	497	303
STA. N/A		TO STA. N/A		
FED. ROAD DIST. NO.		ILLINOIS FED. AID PROJECT		
CONTRACT NO. 70514				

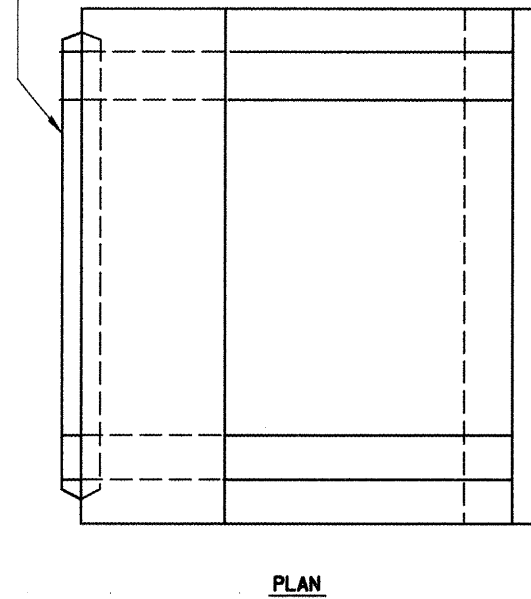
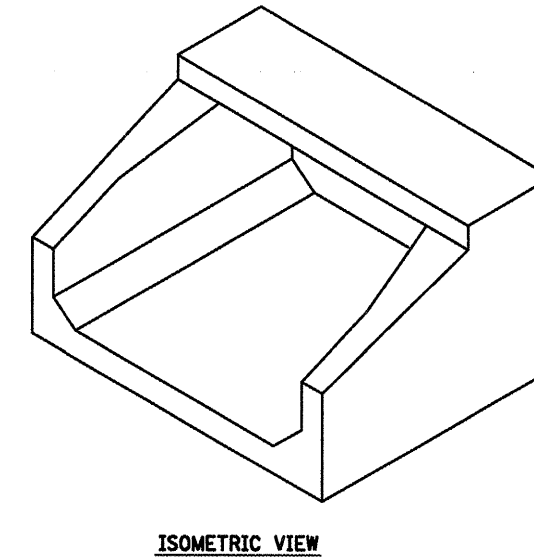
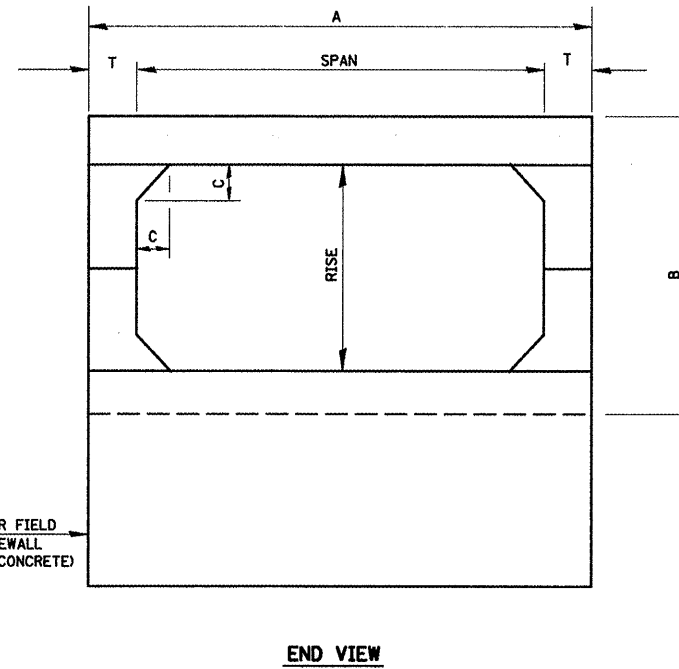
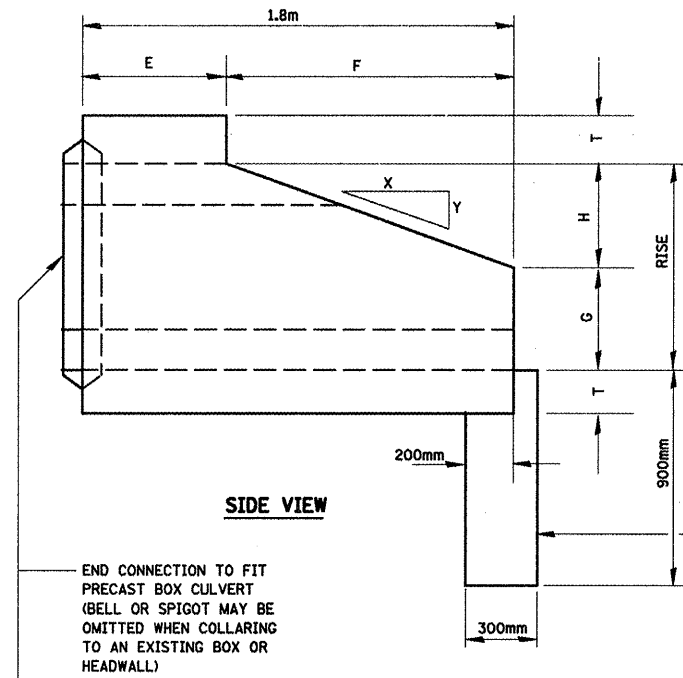

SPAN X RISE (m / mm)	T (mm)	A (m/mm)	B (m/mm)	C (mm)	E (m/mm)	F (m/mm)	G (m/mm)	H (m/mm)	SLOPE
610 X 610	102	813	813	102	914	914	305	305	1 : 3
914 X 610	102	1,118	813	102	914	914	305	305	1 : 3
914 X 914	102	1,118	1,118	102	610	1,219	508	406	1 : 3
1,219 X 610	127	1,473	864	127	914	914	305	305	1 : 3
1,219 X 914	127	1,473	1,168	127	610	1,219	508	406	1 : 3
1,219 X 1,219	127	1,473	1,473	127	610	1,219	610	610	1 : 2
1,524 X 610	152	1,829	914	152	914	914	305	305	1 : 3
1,524 X 914	152	1,829	1,219	152	610	1,219	508	406	1 : 3
1,524 X 1,219	152	1,829	1,524	152	610	1,219	610	610	1 : 2
1,524 X 1,524	152	1,829	1,829	152		1,219	914	610	1 : 2
1,829 X 610	178	2,184	965	178	914	914	305	305	1 : 3
1,829 X 914	178	2,184	1,270	178	610	1,219	508	406	1 : 3
1,829 X 1,219	178	2,184	1,575	178	610	1,219	610	610	1 : 2
1,829 X 1,524	178	2,184	1,880	178		1,219	914	610	1 : 2
2,134 X 914	203	2,540	1,321	203		1,219	508	406	1 : 3
2,134 X 1,219	203	2,540	1,626	203		1,219	610	610	1 : 2
2,134 X 1,524	203	2,540	1,930	203		1,219	914	610	1 : 2
2,438 X 914	203	2,845	1,321	203		1,219	508	406	1 : 3
2,438 X 1,219	203	2,845	1,626	203		1,219	610	610	1 : 2
2,438 X 1,524	203	2,845	1,930	203		1,219	914	610	1 : 2
2,743 X 914	229	3,200	1,372	229		1,219	508	406	1 : 3
2,743 X 1,219	229	3,200	1,676	229		1,219	610	610	1 : 2
2,743 X 1,524	229	3,200	1,981	229		1,219	914	610	1 : 2
3,048 X 1,219	254	3,556	1,499	254		1,219	610	610	1 : 2
3,048 X 1,524	254	3,556	2,032	254		1,219	914	610	1 : 2

**PRECAST CONCRETE BOX
CULVERT END SECTION
(914 mm x 610 mm)**

(EXTENSION OF 900X600 RCBC @ GREENWOOD AVE. STA. 10+685.810, 5.409 m RT.)

CODE NO.	PAY ITEM	UNIT	QUANTITY
54001001	BOX CULVERT END SECTIONS, CULVERT NO. 1	EACH	1

540-16

REVISIONS		ILLINOIS DEPARTMENT OF TRANSPORTATION
NAME	DATE	
		DISTRICT DETAILS
DATE 05-27-09		DRAWN BY SAM CHECKED BY PMH