

ITS ELEMENTS	STA.	PLAN SHEET
CCTV		
027003.2A.27C(EX.)	258+89	2A OF 4
027004.5A.28C(EX.)	327+00	4B OF 4
DETECTION		
027003.2A.69R(EX.)	258+89	2A OF 4
027004.1E.75R	308+30,100'RT	4A OF 4
027004.5A.70D(EX.)	327+00	4B OF 4

FIELD EQUIPMENT NUMBERING SYSTEM	
EXAMPLE : 006402.8W.11D	
0064	DESIGNATES HIGHWAY WHERE FIELD EQUIPMENT IS LOCATED.
006402.8	DESIGNATES MILE MARKER WHERE FIELD EQUIPMENT IS LOCATED.
006402.8W	DESIGNATES DIRECTION VIDEO DETECTOR IS MONITORING TRAFFIC OR DIRECTION TRAFFIC IS TRAVELLING TO RECEIVE DMS MESSAGE.
006402.8W.11	NUMBER ASSIGNED TO THAT FIELD EQUIPMENT
006402.8W.11D	A = ALL DIRECTIONS D = VEHICLE DETECTION C = CAMERA (P/T/Z SURVEILLANCE) H = HAR SIGNAGE WITH BEACON R = RADAR DETECTION

TRAFFIC VOLUME SCHEDULE				
LOCATION	YEAR	ADT (ESTIMATED)	SU%	MUX
EB I-270 TO OLD ALTON RD.	2010	225	4.4	0.0
EB I-270 FROM IL 3 TO OLD ALTON RD.	2010	26200	4.3	17.7
WB I-270 FROM IL 3 TO OLD ALTON RD.	2010	19700	4.3	17.7
EB I-270 WEST OF IL 3	2010	29800	2.8	16.3
WB I-270 WEST OF IL 3	2010	28300	2.2	16.4
NB IL 3 RAMP TO EB I-270	2010	2250	5.7	17.0
EB I-270 RAMP TO NB IL 3	2010	1950	4.2	7.9
NB IL 3 (S. OF I-270)	2010	9600	6.8	7.4
SB IL 3 (S. OF I-270)	2010	9800	7.7	7.7
SB IL 3 RAMP TO EB I-270	2010	1200	7.0	10.9
EB I-270 RAMP TO SB IL 3	2010	2600	4.9	7.8

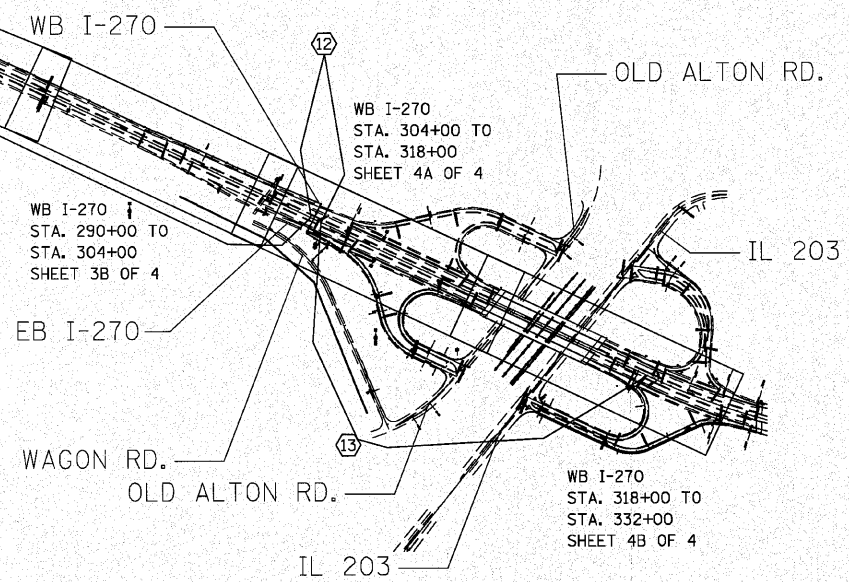

14
NORTH OF I-270 STA. 469+00
@ NB I-255 STA. 1619+50
MP30.9 CONTROLLER CABINET

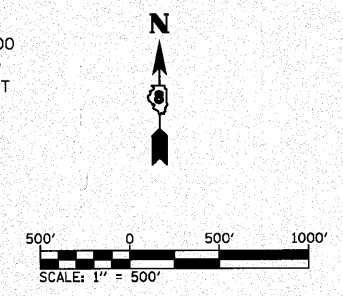

LANE RESTRICTIONS SCHEDULE

SUNDAY				MONDAY				TUESDAY				WEDNESDAY			
LANE RESTRICTIONS PERMITTED	NO LANE RESTRICTIONS PERMITTED							LANE RESTRICTIONS PERMITTED	NO LANE RESTRICTIONS PERMITTED			LANE RESTRICTIONS PERMITTED	NO LANE RESTRICTIONS PERMITTED		
12A 3A 5A 9A 10A 12P 3P 4P 6P 9P	12A 3A 5A 9A 12P 3P 6P 9P	12A 3A 5A 9A 12P 3P 6P 9P	12A 3A 5A 9A 12P 3P 6P 9P	12A 3A 5A 9A 12P 3P 6P 9P	12A 3A 5A 9A 12P 3P 6P 9P	12A 3A 5A 9A 12P 3P 6P 9P	12A 3A 5A 9A 12P 3P 6P 9P	12A 3A 5A 9A 12P 3P 6P 9P	12A 3A 5A 9A 12P 3P 6P 9P	12A 3A 5A 9A 12P 3P 6P 9P	12A 3A 5A 9A 12P 3P 6P 9P	12A 3A 5A 9A 12P 3P 6P 9P	12A 3A 5A 9A 12P 3P 6P 9P	12A 3A 5A 9A 12P 3P 6P 9P	
WEDNESDAY				THURSDAY				FRIDAY				SATURDAY			
NO LANE RESTRICTIONS PERMITTED				LANE RESTRICTIONS PERMITTED	NO LANE RESTRICTIONS PERMITTED			LANE RESTRICTIONS PERMITTED	NO LANE RESTRICTIONS PERMITTED						LANE RESTRICTIONS PERMITTED
12P 3P 6P 9P	12A 3A 5A 9A 12P 3P 6P 9P	12A 3A 5A 9A 12P 3P 6P 9P	12A 3A 5A 9A 12P 3P 6P 9P	12A 3A 5A 9A 12P 3P 6P 9P	12A 3A 5A 9A 12P 3P 6P 9P	12A 3A 5A 9A 12P 3P 6P 9P	12A 3A 5A 9A 12P 3P 6P 9P	12A 3A 5A 9A 12P 3P 6P 9P	12A 3A 6A 9A 10A 12P 3P 4P 6P 9P	12A 3A 5A 9A 12P 3P 6P 9P	12A 3A 5A 9A 12P 3P 6P 9P	12A 3A 5A 9A 12P 3P 6P 9P	12A 3A 5A 9A 12P 3P 6P 9P	12A 3A 5A 9A 12P 3P 6P 9P	

TRAFFIC CONTROL AND PROTECTION ZONES

TRAFFIC CONTROL AND PROTECTION STANDARDS	① EB I-270 228+63 TO SB IL 3 1362+72	② SB IL 3 1362+72 TO NB IL 3 1362+81	③ NB IL 3 1362+81 TO EB I-270 237+85	④ EB I-270 237+85 TO EB I-270 242+67	⑤ EB I-270 242+67 TO EB I-270 242+83	⑥ EB I-270 242+83 TO EB I-270 251+95	⑦ EB I-270 251+95 TO WB I-270 251+95	⑧ WB I-270 251+95 TO WB I-270 255+70	⑨ WB I-270 255+70 TO WB I-270 258+12	⑩ WB I-270 258+12 TO WB I-270 307+00	⑪ WB I-270 307+00 TO EB I-270 327+50	⑫ EB I-270 307+00 TO 308+18	⑬ I-270 469+00 @ NB I-255 MP30.9	TOTALS
701101	X	X	X	X	X	X	X	X	X	X	X	X	X	NA
701106	X	X	X	X	X	X	X	X	X	X	X	X	X	NA
701201														1.00 L SUM
701400														NA
701406		0.25 L SUM		0.125 L SUM			0.25 L SUM	0.125 L SUM			0.25 L SUM			1.00 L SUM
701411		2.00 EACH		2.00 EACH			2.00 EACH	2.00 EACH			1.00 EACH			9.00 EACH
701456		0.20 L SUM		0.20 L SUM		0.20 L SUM					0.20 L SUM			1.00 L SUM

*USE 701400, ALSO