

STATE OF ILLINOIS
DEPARTMENT OF TRANSPORTATION

F.A.P. RTE.	SECTION	COUNTY	TOTAL SHEETS	SHEET NO.
664	(21RS-10,G-RS-16)PP	SANGAMON	32	1
		ILLINOIS	CONTRACT NO. 72N10	

- INDEX OF SHEETS**
 1 COVER SHEET
 2 GENERAL NOTES
 3 SUMMARY OF QUANTITIES
 4 SCHEDULE OF QUANTITIES
 5-17 TYPICAL SECTIONS
 18-32 PLAN SHEETS

STANDARDS

- 701006-05 000001-08
 701427-05 001006
 701701-10 442201-03
 701901-08 701602-10
 780001-05

TRAFFIC DATA

2020 ADT = 20,846

FUNCTIONAL CLASSIFICATION
 OTHER PRINCIPAL ARTERIAL

**PROPOSED
HIGHWAY PLANS**

**FAP ROUTE 664 (WABASH AVE/MACARTHUR BLVD)
SECTION (21RS-10,G-RS-16)PP
PROJECT STATE ONLY
REACTIVE MAINTENANCE
SANGAMON COUNTY**

C-96-136-21

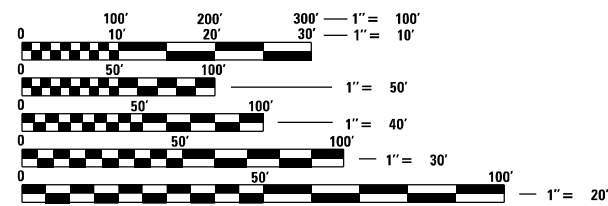
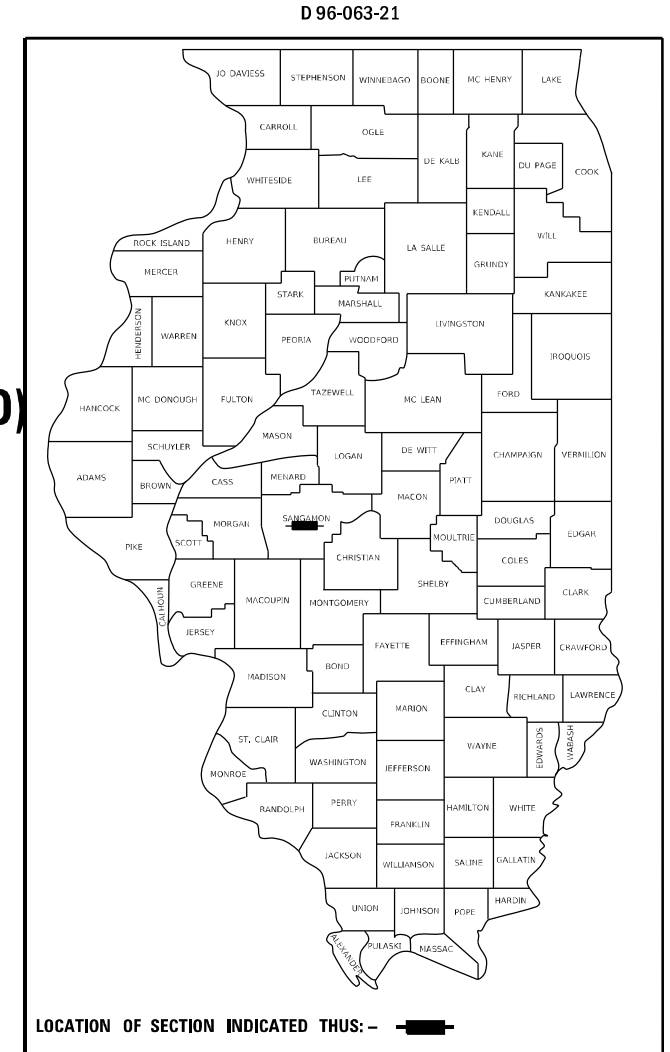

FULL SIZE PLANS HAVE BEEN PREPARED USING STANDARD ENGINEERING SCALES. REDUCED SIZED PLANS WILL NOT CONFORM TO STANDARD SCALES. IN MAKING MEASUREMENTS ON REDUCED PLANS, THE ABOVE SCALES MAY BE USED.

J.U.L.I.E.
 JOINT UTILITY LOCATION INFORMATION FOR EXCAVATORS
 1-800-892-0123
 OR 811

T 16 N
T 15 N

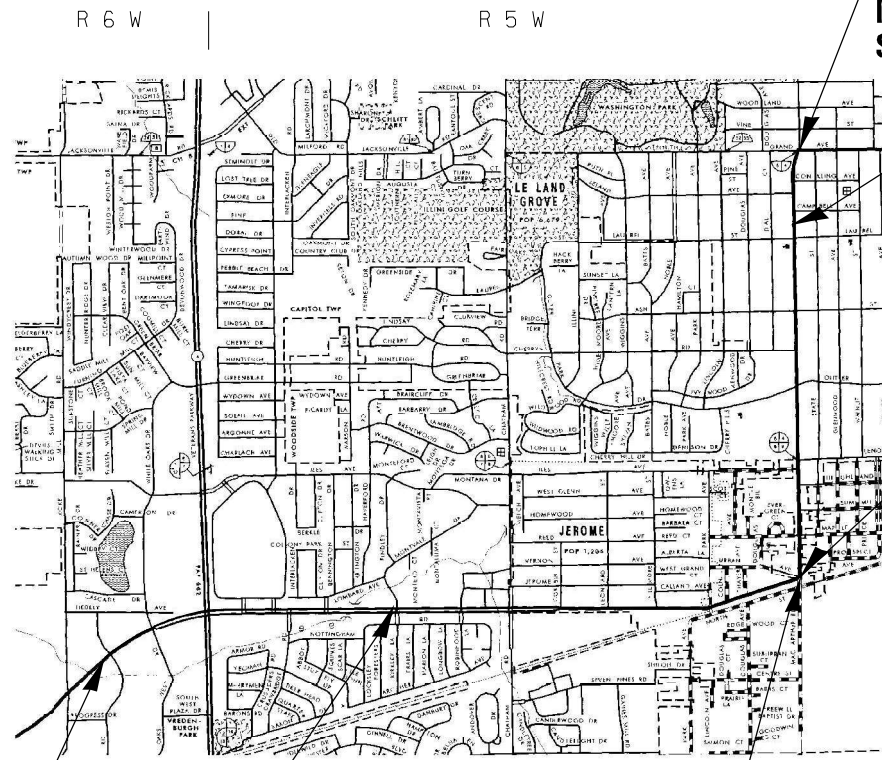

**END OF PROJECT:
MACARTHUR BLVD
STATION 12 + 7.9**

**STATION EQUATION:
STA. 687 + 04.85 (BACK)
STA. 00 + 00 (AHEAD)**

**STA 620 + 20.92 (MACARTHUR BLVD) =
STA 101 + 89.048 (WABASH AVE)**

**BEGINNING OF PROJECT:
WABASH AVE
STATION 492 + 79.38**

**STATION EQUATION:
STA. 554 + 99.18 (BACK)
STA. 555 + 00.00 (AHEAD)**

**STATION EQUATION:
STA. 603 + 08.51 (BACK)
STA. 83 + 28.31 (AHEAD)**

NET LENGTH = 20,697.6 FT. = 3.92 MILES

PROJECT ENGINEER: JAY EDWARDS (217) 785-0597
 PROJECT MANAGER: FILIBERTO SOTELO (217) 524-0946

CONTRACT NO. 72N10

STATE OF ILLINOIS
 DEPARTMENT OF TRANSPORTATION

SUBMITTED October 27 20 21

Jay P. Myers REGIONAL ENGINEER
 December 10 21
Stephen M. Frazier ENGINEER OF DESIGN AND ENVIRONMENT
 December 10 21
 DIRECTOR OF HIGHWAYS PROJECT IMPLEMENTATION 2

**PRINTED BY THE AUTHORITY
OF THE STATE OF ILLINOIS**

GENERAL NOTES

1. THE CONTRACTOR SHALL NOTIFY THE DISTRICT 6 BUREAU OF OPERATIONS AT (217) 785-5306 THREE WEEKS PRIOR TO IMPLEMENTING ANY TRAFFIC CONTROL
2. ALL PATCH STATION REFERENCES ARE APPROXIMATE AND MAY BE ADJUSTED IN THE FIELD
3. THE FOLLOWING MIXTURE REQUIREMENTS ARE APPLICABLE

MIXTURE USE(S):	PARTIAL DEPTH PATCHING
AC/PG:	PG 64-22
DESIGN AIR VOIDS:	4.0% @ N70
MIXTURE COMPOSITION:	IL-9.5
FRICTION AGGREGATE:	MIX "D"
MIXTURE WEIGHT:	112 lb/sy*in
QUALITY MANAGEMENT:	QC/QA
SUBLOT SIZE:	N/A
MATERIAL TRANSFER DEVICE REQUIRED:	NO

COMMITMENTS

NONE

**STATE OF ILLINOIS
DEPARTMENT OF TRANSPORTATION
DIVISION OF HIGHWAYS
DISTRICT 6**

EXAMINED October 26 2021

[Signature]
ENGINEER OF OPERATIONS

EXAMINED October 26 2021

[Signature]
ENGINEER OF PROJECT IMPLEMENTATION

EXAMINED October 26 2021

[Signature]
ENGINEER OF PROGRAM DEVELOPMENT

MODEL: Default
 FILE: Main1.dwg
 PLOT DATE: 10/25/2021
 USER: sotelar
 PLOT SCALE: 1000.0000' / in.
 PLOT DATE: 10/25/2021

USER NAME = sotelar	DESIGNED -	REVISED -
	DRAWN -	REVISED -
PLOT SCALE = 1000.0000' / in.	CHECKED -	REVISED +
PLOT DATE = 10/25/2021	DATE -	REVISED +

**STATE OF ILLINOIS
DEPARTMENT OF TRANSPORTATION**

GENERAL NOTES	
SCALE:	SHEET 1 OF 1 SHEETS STA. TO STA.

F.A.P. RTE.	SECTION	COUNTY	TOTAL SHEETS	SHEET NO.
664	(21RS-10, G-RS-16)PP	SANGAMON	32	2
			CONTRACT NO. 72N10	
ILLINOIS FED. AID PROJECT				

CODE NO.	ITEM	UNIT	TOTAL QUANTITY	CONSTR. CODE	
				PPS # 6-01065-0000 STATE 100%	
				ROADWAY	
				0006	URBAN
44201385	CLASS C PATCHES, TYPE I, 13 INCH	SQ YD	4	4	
44201389	CLASS C PATCHES, TYPE II, 13 INCH	SQ YD	60	60	
44201394	CLASS C PATCHES, TYPE III, 13 INCH	SQ YD	35	35	
44201396	CLASS C PATCHES, TYPE IV, 13 INCH	SQ YD	128	128	
44201411	CLASS C PATCHES, TYPE I, 15 INCH	SQ YD	7	7	
44201415	CLASS C PATCHES, TYPE II, 15 INCH	SQ YD	141	141	
44201419	CLASS C PATCHES, TYPE III, 15 INCH	SQ YD	36	36	
44201421	CLASS C PATCHES, TYPE IV, 15 INCH	SQ YD	149	149	
60255500	MANHOLES TO BE ADJUSTED	EACH	1	1	
67100100	MOBILIZATION	L SUM	1	1	
70102632	TRAFFIC CONTROL AND PROTECTION, STANDARD 701602	L SUM	1	1	
70102635	TRAFFIC CONTROL AND PROTECTION, STANDARD 701701	L SUM	1	1	
70300100	SHORT TERM PAVEMENT MARKING	FOOT	570	570	
70300150	SHORT TERM PAVEMENT MARKING REMOVAL	SQ FT	237.5	237.5	

CODE NO.	ITEM	UNIT	TOTAL QUANTITY	CONSTR. CODE	
				PPS # 6-01065-0000 STATE 100%	
				ROADWAY	
				0006	URBAN
78009005	MODIFIED URETHANE PAVEMENT MARKING -- LINE 5"	FOOT	5180	5180	
78009006	MODIFIED URETHANE PAVEMENT MARKING -- LINE 6"	FOOT	520	520	
78100100	RAISED REFLECTIVE PAVEMENT MARKER	EACH	140	140	
78300200	RAISED REFLECTIVE PAVEMENT MARKER REMOVAL	EACH	140	140	
X4405020	LONGITUDINAL PARTIAL DEPTH REMOVAL 2"	FOOT	3080	3080	
X4406020	PARTIAL DEPTH REMOVAL, TYPE I, 2"	SQ YD	8	8	
X4406220	PARTIAL DEPTH REMOVAL, TYPE II, 2"	SQ YD	251	251	
X4406420	PARTIAL DEPTH REMOVAL, TYPE III, 2"	SQ YD	598	598	
X4406620	PARTIAL DEPTH REMOVAL, TYPE IV, 2"	SQ YD	658	658	
X4420900	LONGITUDINAL PARTIAL DEPTH PATCHING	TON	57	57	
X4421000	PARTIAL DEPTH PATCHING	TON	170	170	

REV. - MS

MODEL: D:\draft
 FILE: NAME: p:\w\dot-cw\benefit\com\PNW\DOT\Documents\DOT_Offices\District_6\Projects\0672N10\CAD\DATA_0672N10\sp-500.dgn

USER NAME = sotelar DESIGNED - DRAWN - PLOT SCALE = 100.0000' / in. CHECKED - PLOT DATE = 10/25/2021 DATE -	REVISED - REVISED - REVISED + REVISED +	STATE OF ILLINOIS DEPARTMENT OF TRANSPORTATION	SUMMARY OF QUANTITIES	F.A.P. RTE. 664 SECTION (21RS-10,G-RS-16)PP COUNTY SANGAMON ILLINOIS FED. AID PROJECT	TOTAL SHEETS 32 SHEET NO. 3 CONTRACT NO. 72N10
-------------------------------------------------------------------------------------------------------------------------------	--------------------------------------------------	-----------------------------------------------------------------	------------------------------	------------------------------------------------------------------------------------------------	------------------------------------------------------

PARTIAL DEPTH PATCHING AND REMOVAL					X4406020	X4406020	X4406420	X4406620	X4421000	78009005	78009006	78100100	78300200
START STA	END STA	DIRECTION/LANE	LENGTH (FOOT)	WIDTH (FOOT)	I (SQ YD)	II (SQ YD)	III (SQ YD)	IV (SQ YD)	HMA (TONS)	MOD URETHANE PVM-5" (FOOT)	MOD URETHANE PVM-6" (FOOT)	RRPM (EACH)	RRPM REMOVAL (EACH)
SOUTH MACARTHUR BOULEVARD													
640+20	642+00	NBDL	180	11				220	24.6	180		5	5
640+20	642+00	NBPL	180	11				220.0	24.6	180		5	5
673+68	673+90	NBPL	22	11		26.9			3.0	22		1	1
681+40	681+70	NBDL	30	4		13.3			1.5	30		1	1
682+30	682+80	NBDL	50	4		22.2			2.5	50		1	1
684+45	685+75	NBDL	130	4			57.8		6.5	130		3	3
639+80	640+35	SBDL	55	11			67.2		7.5	55		1	1
639+80	640+35	SBPL	55	11			67.2		7.5	55		1	1
642+36	643+10	SBDL	74	4		32.9			3.7	74		2	2
664+50	665+40	SDDL/RTL	90	6			60.0		6.7		90	0	0
668+80	669+50	SBDL	70	4		31.1			3.5	70		2	2
670+60	671+15	SBDL	55	11			67.2		7.5	55		1	1
675+00	675+18	SBDL	18	4		8.0			0.9	18		0	0
677+30	678+25	SBPL	95	11				116.1	13.0	95		2	2
677+75	678+25	SBDL	50	11			61.1		6.8	50		1	1
680+40	681+00	SBDL	60	11			73.3		8.2	60		2	2
680+40	681+00	SBPL	60	11			73.3		8.2	60		2	2
685+55	0+15	SBPL	160	4			71.1		8.0	160		4	4
0+40	0+57	SBPL	17	4	7.6				0.8	17		0	0
0+50	2+80	SBDL	230	4				102.2	11.4	230		6	6
2+90	3+40	SBPL	50	4		22.2			2.5	50		1	1
4+10	4+32	SBDL	22	4		9.8			1.1	22		1	1
5+00	5+50	SBDL	50	4		22.2			2.5	50		1	1
7+40	8+25	SBDL	85	4		37.8			4.2	85		2	2
8+30	8+50	SBDL	20	11		24.4			2.7	20		1	1
Totals					8	251	598	658	170	1818	90	45	45

LONGITUDINAL PARTIAL DEPTH PATCHING					X4405020	X4420900	78009005	78009006	78100100	78300200
START STA	END STA	DESCRIPTION	WIDTH (FOOT)	DEPTH (IN)	Length (FOOT)	HMA (TONS)	MOD URETHANE PVM-5" (FOOT)	MOD URETHANE PVM-6" (FOOT)	RRPM (EACH)	RRPM REMOVAL (EACH)
SOUTH MACARTHUR BOULEVARD										
643+10	646+40	NBPL - RWP	2	1.5	330	6.2	330		8	8
651+50	663+60	NBL - Centerline	2	1.5	210	3.9	210		5	5
670+00	676+00	NBL - Centerline	2	1.5	600	11.2	600		15	15
683+60	685+10	NBL - Centerline	2	1.5	150	2.8	150		4	4
5+50	9+00	NBL - Centerline	2	1.5	250	4.7	250		6	6
641+50	644+20	SBPL - RWP	2	1.5	270	5.0	270		7	7
643+20	648+50	SBL - Centerline	2	1.5	530	9.9	530		13	13
649+80	652+40	SBL - RTL	2	1.5	260	4.9		260	7	7
657+50	659+20	SBL-RTL	2	1.5	170	3.2		170	4	4
679+80	680+40	SBL - Centerline	2	1.5	60	1.1	60		2	2
682+00	682+50	SBPL - Diagonal	2	1.5	50	0.9	50		1	1
683+50	685+50	SBL - Centerline	2	1.5	200	3.7	200		5	5
Totals					3080	57	2650	430	77	77

SHORT TERM PAVEMENT MARKING AND REMOVAL		
	70300100	70300150
TOTAL	570	570

CLASS C PATCHES					44201411	44201415	44201419	44201421	78009005	78100100	78300200
STA	DIRECTION/LANE	LENGTH (FOOT)	WIDTH (FOOT)	DEPTH (IN)	I (SQ YD)	II (SQ YD)	III (SQ YD)	IV (SQ YD)	MOD URETHANE PVM-5" (FOOT)	RRPM (EACH)	RRPM REMOVAL (EACH)
WABASH AVENUE											
538+90	EBDL	32	12	15				42.6	32	1	1
566+45	WBDL	28	12	15				37.3	28	1	1
585+25	EBPL	30	12	15				40	30	1	1
586+80	WBDL	22	12	15				29.3	22	1	1
587+75	WBDL	8	12	15		10.6			8	0	0
SOUTH MACARTHUR BOULEVARD											
663+90	NBDL	30	4	15		13.3			30	1	1
665+10	NBDL	16	11	15			19.6		16	0	0
674+50	NBDL	8	11	15		9.8			8	0	0
675+70	NBDL	6	11	15		7.3			6	0	0
676+20	NBDL	8	11	15		9.8			8	0	0
679+50	NBDL	15	4	15		6.7			15	0	0
680+00	NBDL	8	4	15	3.6				8	0	0
681+75	NBDL	8	4	15	3.6				8	0	0
640+60	SBDL	8	11	15		9.8			8	0	0
640+60	SBPL	8	11	15		9.8			8	0	0
642+00	SBDL	36	4	15			16.0		36	1	1
666+70	SBDL	10	11	15		12.2			10	0	0
670+40	SBDL	6	11	15		7.3			6	0	0
674+10	SBDL	6	11	15		7.3			6	0	0
674+50	SBDL	8	11	15		9.8			8	0	0
675+60	SBDL	20	4	15		8.9			20	1	1
677+25	SBDL	6	11	15		7.3			6	0	0
682+50	SBDL	24	4	15		10.7			24	1	1
Totals					7	141	36	149	351	9	9

CLASS C PATCHES					44201385	44201389	44201394	44201396	78009005	78100100	78300200	60255500
STA	DIRECTION/LANE	LENGTH (FOOT)	WIDTH (FOOT)	DEPTH (IN)	I (SQ YD)	II (SQ YD)	III (SQ YD)	IV (SQ YD)	MOD URETHANE PVM-5" (FOOT)	RRPM (EACH)	RRPM REMOVAL (EACH)	MAN ADJUST (EACH)
SOUTH MACARTHUR BOULEVARD												
686+10	NBDL	8	12	13		10.7			8	0	0	
0+10	NBDL	26	4	13		11.6			26	1	1	
1+00	NBPL - MH	6	6	13	4.0				6	0	0	1
5+50	NBDL	43	4	13			19.1		43	1	1	
6+50	NBDL	26	12	13				34.7	26	1	1	
8+40	NBDL	24	4	13		10.7			24	1	1	
8+50	NBPL	28	4	13		12.4			28	1	1	
684+70	SBDL	90	4	13				40.0	90	2	2	
685+90	SBDL	36	4	13			16.0		36	1	1	
686+30	SBDL	17	4	13		7.6			17	0	0	
686+70	SBDL	17	4	13		7.6			17	0	0	
8+50	SBPL	40	12	13			53.3		40	1	1	
Totals					4	60	35	128	361	9	9	1

MODEL: Default
 FILE: \\m11e-pw-bentley.com\PWDOT\Documents\DOT Office\Director: E:\Projects\0672N10\0672N10-CAD\Draw: 55101-CAD\SheetSet\0672N10-Sch-CenCell.bgn

USER NAME = sotelof	DESIGNED -	REVISED -
	DRAWN -	REVISED -
PLOT SCALE = 100,0000' / in.	CHECKED -	REVISED -
PLOT DATE = 10/25/2021	DATE -	REVISED -

**STATE OF ILLINOIS
DEPARTMENT OF TRANSPORTATION**

SCHEDULES

SCALE: SHEET 1 OF 1 SHEETS STA. TO STA.

F.A.P. RTE.	SECTION	COUNTY	TOTAL SHEETS	SHEET NO.
664	(21R5-10, G-R5-16) PP	SANGAMON	32	4
CONTRACT NO. 72N10				
ILLINOIS FED. AID PROJECT				

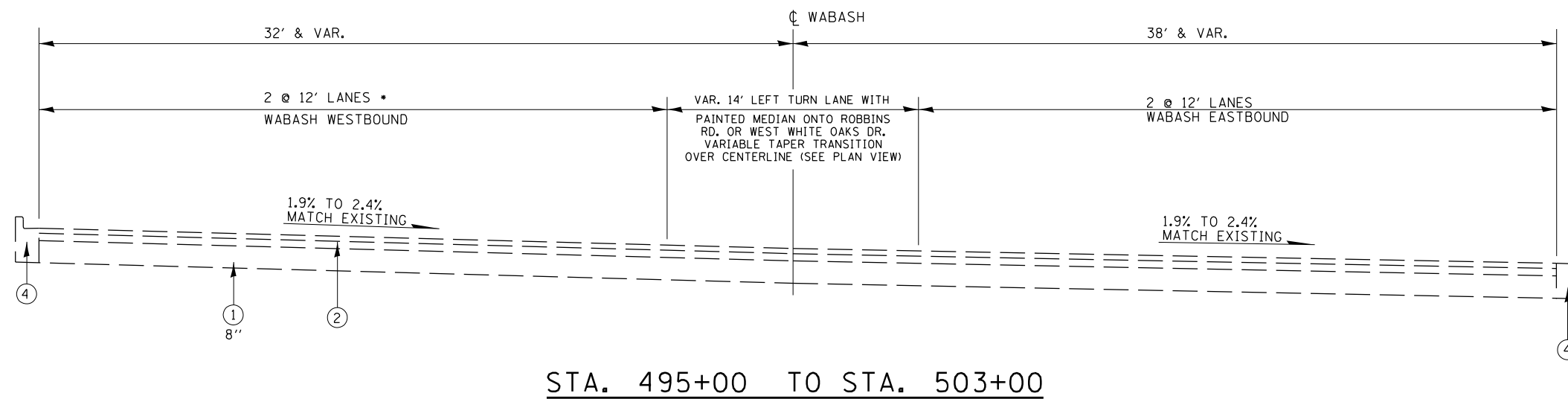
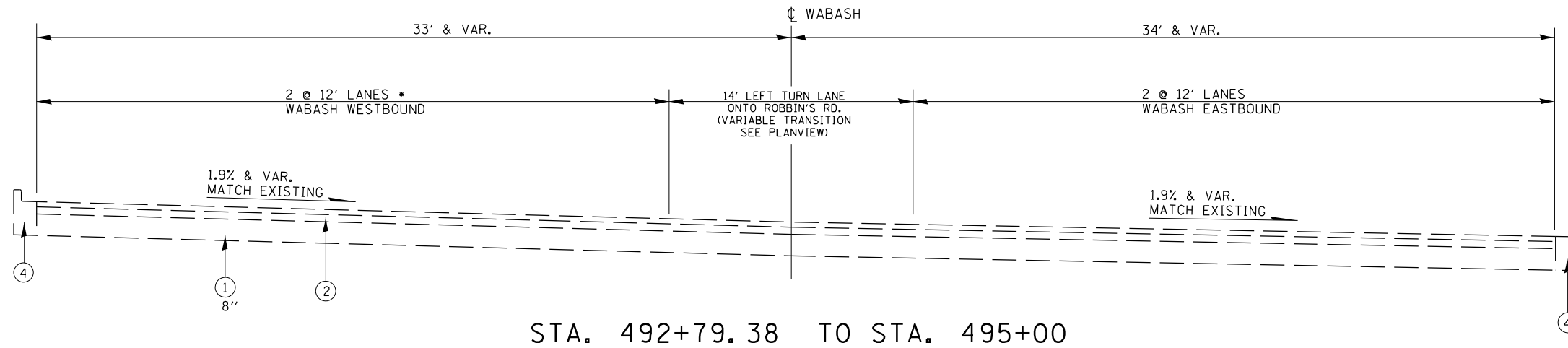

* WABASH AVENUE-WESTBOUND RIGHT TURN LANE
STA. 495+50.00 TO 500+23.00

EXISTING LEGEND

- ① PCC PAVEMENT
- ② HMA SURFACE, 3 1/2" MINIMUM & VARIABLE
- ③ CONCRETE MEDIAN
- ④ CURB & GUTTER
- ⑤ SUB-BASE GRANULAR MATERIAL, TY B (DEPTH = 4")
- ⑥ BASE COURSE (OPTION), (10 1/2" DEPTH)
- ⑦ HMA SURFACE, 1 1/2"
- ⑧ PAVEMENT MARKING 5"
- ⑨ COMBINATION CONCRETE CURB & GUTTER, TYP B-6.24
- ⑩ CONCRETE MEDIAN SURFACE, 4"

NOT TO SCALE

MODEL: Default
 FILE NAME: p:\project-aw-bead\paw.com\FW\DOT\Documents\DOT Office\Drawings\Project\0672N10\CAD\Drawings\0672N10\csh-cs-typical.dwg

USER NAME = sotelof	DESIGNED -	REVISED -
	DRAWN -	REVISED -
PLOT SCALE = 100,0000' / in.	CHECKED -	REVISED -
PLOT DATE = 10/25/2021	DATE -	REVISED -

**STATE OF ILLINOIS
DEPARTMENT OF TRANSPORTATION**

TYPICAL CROSS SECTIONS WABASH	
SCALE:	SHEET OF SHEETS STA. TO STA.

F.A.P. RTE.	SECTION	COUNTY	TOTAL SHEETS	SHEET NO.
662	(21RS-10, G-RS16) PP	SANGAMON	32	5
CONTRACT NO. 72N10				
ILLINOIS FED. AID PROJECT				

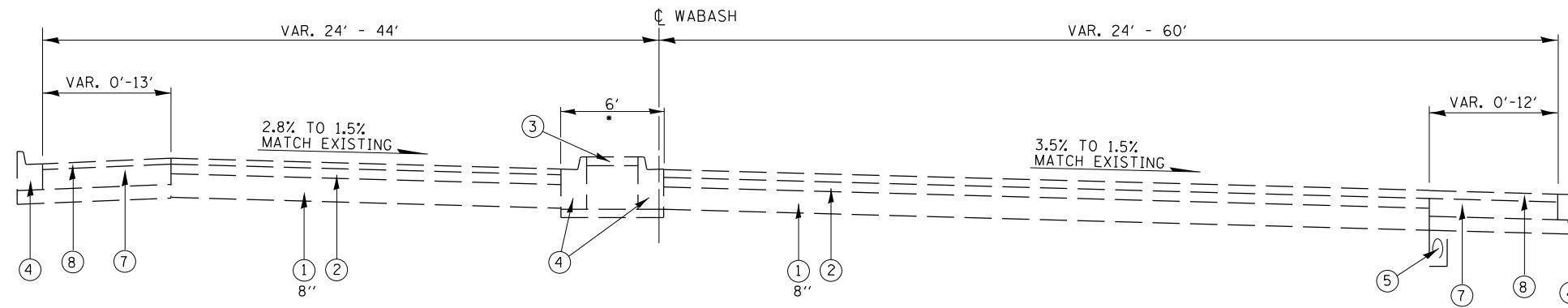

*- EXISTING RAISED CONCRETE
MEDIAN SHIFTS RIGHT TO LEFT
OF CENTERLINE
STA. 504+94 TO STA. 512±13

STA. 503+00 TO STA. 511+70
OMISSION:
STA. 511+70 to STA. 515+00

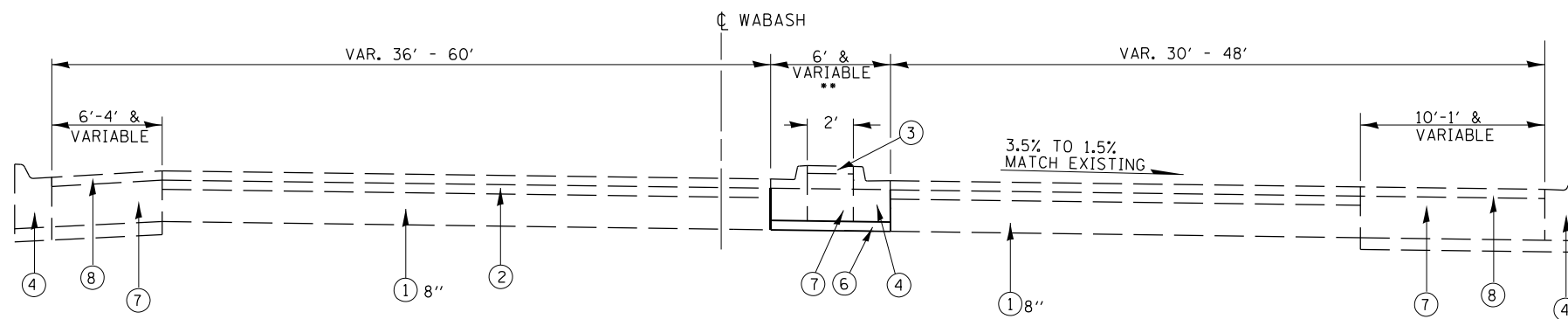

**-- EXISTING RAISED CONCRETE
MEDIAN AND CONCRETE CURB
AND GUTTER REMOVAL AT
STA. 518+15 TO STA. 520+28

STA. 515+00 TO STA. 521+74.15
STATION EQUATION:
STA. 521+74.15 (BK) = STA. 521+79.92 (AHD)
STA. 521+79.92 TO STA. 524+34

EXISTING LEGEND

- ① PCC PAVEMENT
- ② HMA SURFACE, 3 1/2" MINIMUM & VARIABLE
- ③ CONCRETE MEDIAN
- ④ CURB & GUTTER
- ⑤ PIPE UNDERDRAIN
- ⑥ SUB-BASE GRANULAR MATERIAL, TY B (DEPTH = 4")
- ⑦ BASE COURSE (OPTION), (10 1/2" DEPTH)
- ⑧ HMA SURFACE, 1 1/2"
- ⑨ PAVEMENT MARKING 5"
- ⑩ COMBINATION CONCRETE CURB & GUTTER, TYP B-6.24
- ⑪ CONCRETE MEDIAN SURFACE, 4"

MODEL: Default
FILE NAME: p:\project-aw-beadby.com\p\dot\documents\dot\office\dir\dir_6\project\0672N10\CADD\DATA_5510\CADD\sheet\0672N10\sheet-tytical.dgn

USER NAME = sotelof	DESIGNED -	REVISED -
	DRAWN -	REVISED -
PLOT SCALE = 100,0000' / in.	CHECKED -	REVISED -
PLOT DATE = 10/25/2021	DATE -	REVISED -

**STATE OF ILLINOIS
DEPARTMENT OF TRANSPORTATION**

**TYPICAL CROSS SECTIONS
WABASH**

SCALE: SHEET OF SHEETS STA. TO STA.

F.A.P. RTE.	SECTION	COUNTY	TOTAL SHEETS	SHEET NO.
662	(21RS-10, G-RS16) PP	SANGAMON	32	6
CONTRACT NO. 72N10				
ILLINOIS FED. AID PROJECT				

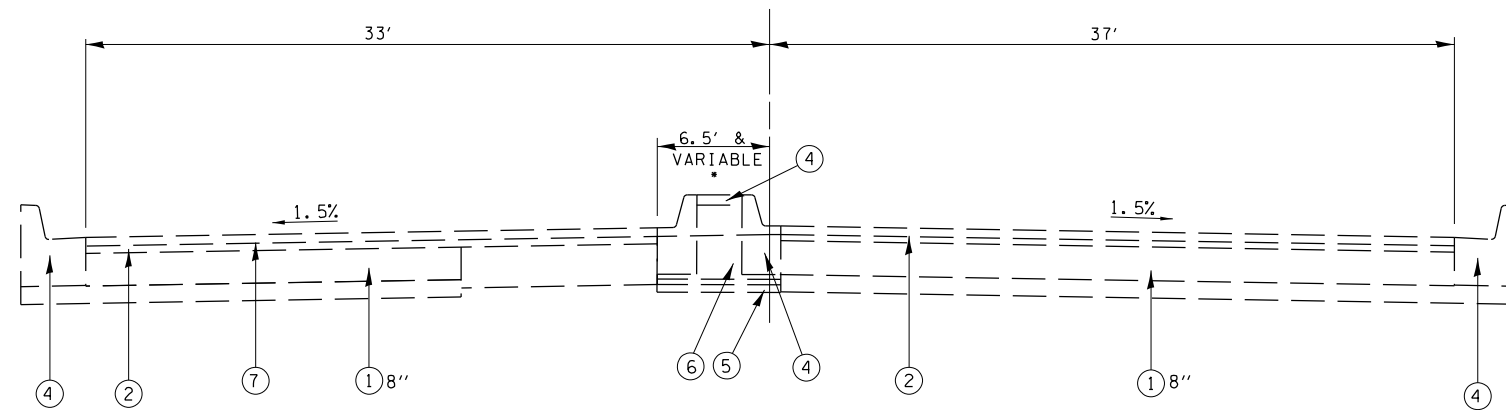

STA 524+35 TO STA 525+89

•• EXISTING RAISED CONCRETE
MEDIAN AND CONCRETE CURB
AND GUTTER REMOVAL AT
STA. 524+35.4 TO STA. 525+89.4

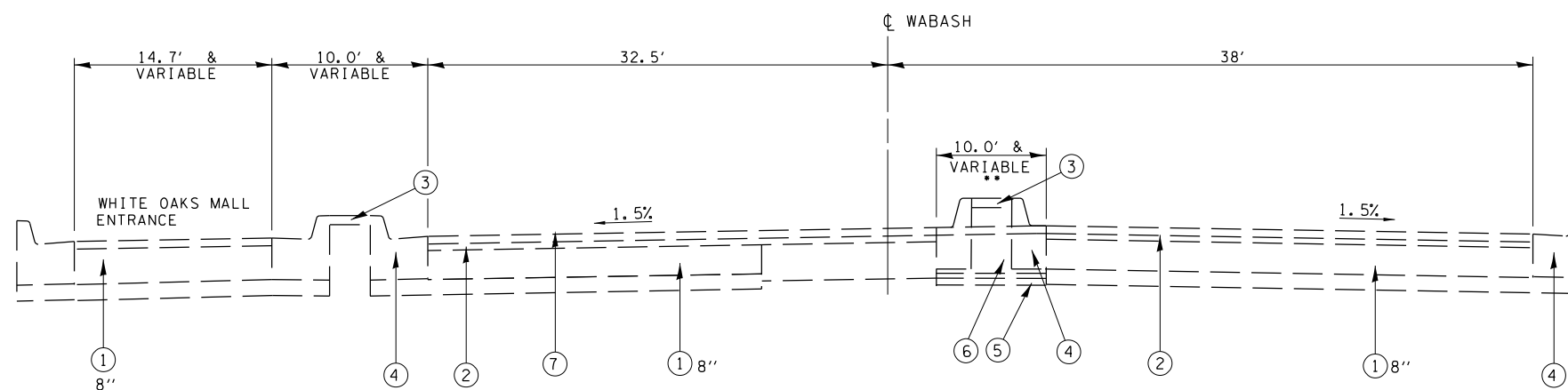

STA 525+89 TO STA 528+28

••• EXISTING RAISED CONCRETE
MEDIAN AND CONCRETE CURB
AND GUTTER REMOVAL AT
STA. 526+65.8 TO STA. 528+28.5

EXISTING LEGEND

- ① PCC PAVEMENT
- ② HMA SURFACE, 3 1/2" MINIMUM & VARIABLE
- ③ CONCRETE MEDIAN
- ④ CURB & GUTTER
- ⑤ SUB-BASE GRANULAR MATERIAL, TY B (DEPTH = 4")
- ⑥ BASE COURSE (OPTION), (10 1/2" DEPTH)
- ⑦ HMA SURFACE, 1 1/2"
- ⑧ PAVEMENT MARKING 5"
- ⑨ COMBINATION CONCRETE CURB & GUTTER, TYP B-6.24
- ⑩ CONCRETE MEDIAN SURFACE, 4"

MODEL: Default
 FILE NAME: p:\ultra-dwg-bead-fay.com\FW\DOT\Documents\DOT Office\Director_E\Project\0672N10\CADD\DATA_5510\CADD\sheet\0672N10\csh-ts-typical.dwg

USER NAME = sotelof	DESIGNED -	REVISED -
	DRAWN -	REVISED -
PLOT SCALE = 100,0000' / in.	CHECKED -	REVISED -
PLOT DATE = 10/25/2021	DATE -	REVISED -

**STATE OF ILLINOIS
DEPARTMENT OF TRANSPORTATION**

**TYPICAL CROSS SECTIONS
WABASH**

SCALE: SHEET OF SHEETS STA. TO STA.

F.A.P. RTE.	SECTION	COUNTY	TOTAL SHEETS	SHEET NO.
662	(21RS-10, G-R516) PP	SANGAMON	32	7
CONTRACT NO. 72N10				
ILLINOIS FED. AID PROJECT				

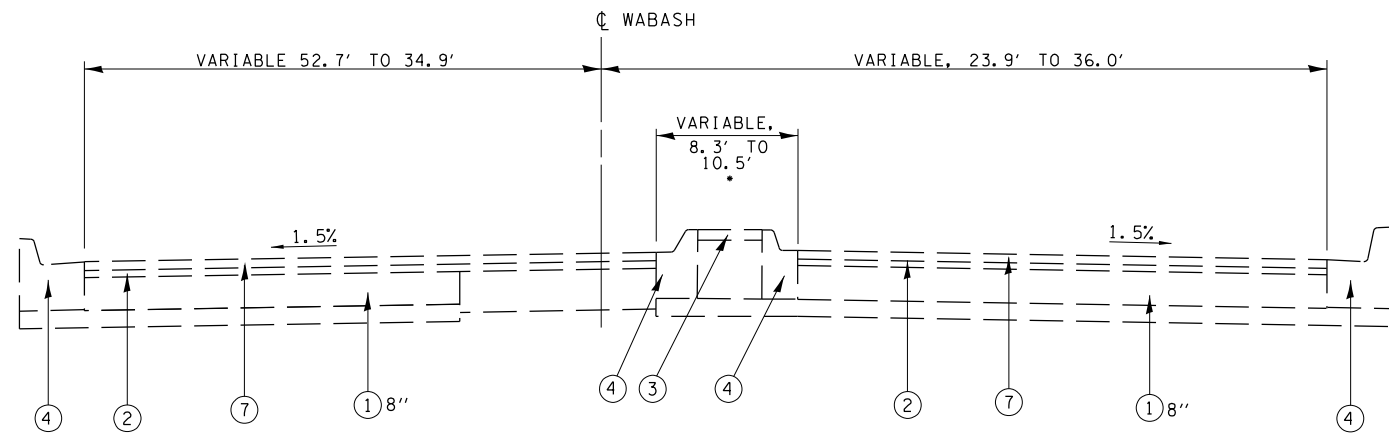

STA 528+28 TO STA 535+75

•• EXISTING RAISED CONCRETE MEDIAN SHIFTS RIGHT TO LEFT OF CENTERLINE STA. 529+07 TO STA. 535+17

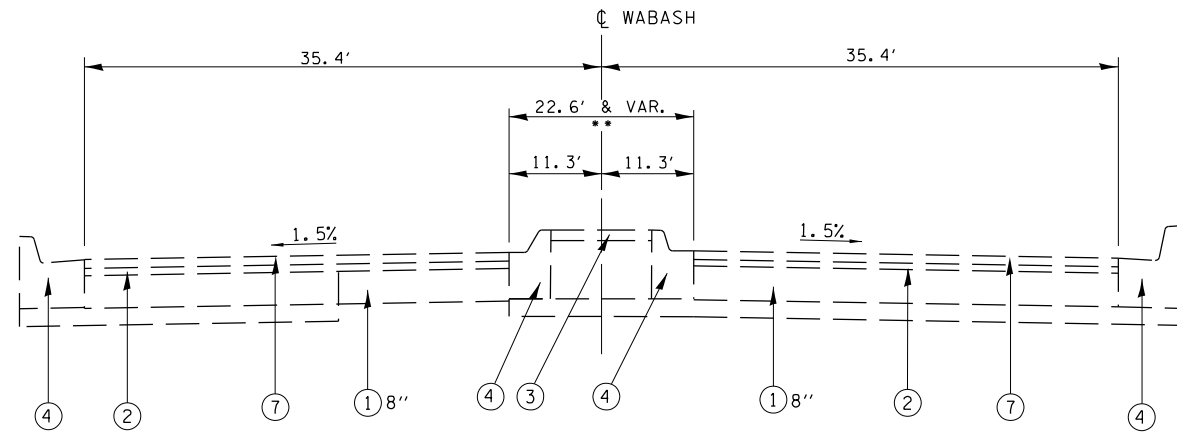

STA 535+75 TO STA 540+44

••• EXISTING RAISED CONCRETE MEDIAN STA 535+83.8 TO STA. 539+88.4

EXISTING LEGEND

- ① PCC PAVEMENT
- ② HMA SURFACE, 3 1/2" MINIMUM & VARIABLE
- ③ CONCRETE MEDIAN
- ④ CURB & GUTTER
- ⑤ SUB-BASE GRANULAR MATERIAL, TY B (DEPTH = 4")
- ⑥ BASE COURSE (OPTION), (10 1/2" DEPTH)
- ⑦ HMA SURFACE, 1 1/2"
- ⑧ PAVEMENT MARKING 5"
- ⑨ COMBINATION CONCRETE CURB & GUTTER, TYP B-6.24
- ⑩ CONCRETE MEDIAN SURFACE, 4"

MODEL: Default
 FILE NAME: p:\project-pw-beadby.com\PI\DOT\Documents\DOT Office\Director_E\Project\0672N10\CADD\03_5510\CADD\sheet\0672N10\cst-cypical.dgn

USER NAME = sotelof	DESIGNED -	REVISED -
	DRAWN -	REVISED -
PLOT SCALE = 100,0000' / in.	CHECKED -	REVISED -
PLOT DATE = 10/25/2021	DATE -	REVISED -

STATE OF ILLINOIS
DEPARTMENT OF TRANSPORTATION

TYPICAL CROSS SECTIONS			
WABASH			
SCALE:	SHEET	OF	SHEETS
	STA.	TO	STA.

F.A.P. RTE.	SECTION	COUNTY	TOTAL SHEETS	SHEET NO.
662	(21RS-10, G-R516) PP	SANGAMON	32	8
			CONTRACT NO. 72N10	
ILLINOIS FED. AID PROJECT				

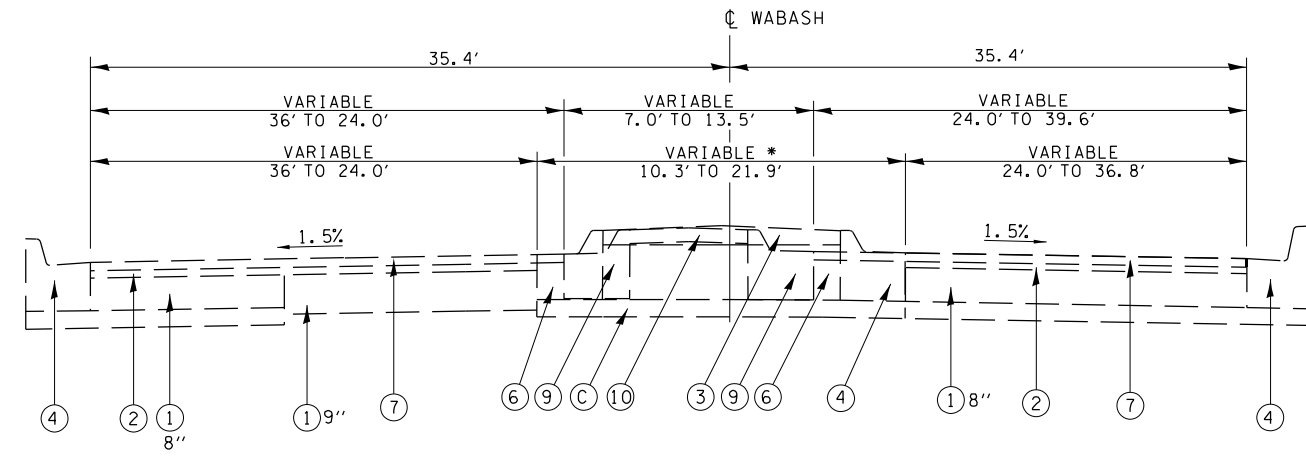

STA 540+44 TO STA 548+46

* - EXISTING RAISED CONCRETE MEDIAN
STA 540+44.2 TO STA. 547+73.6

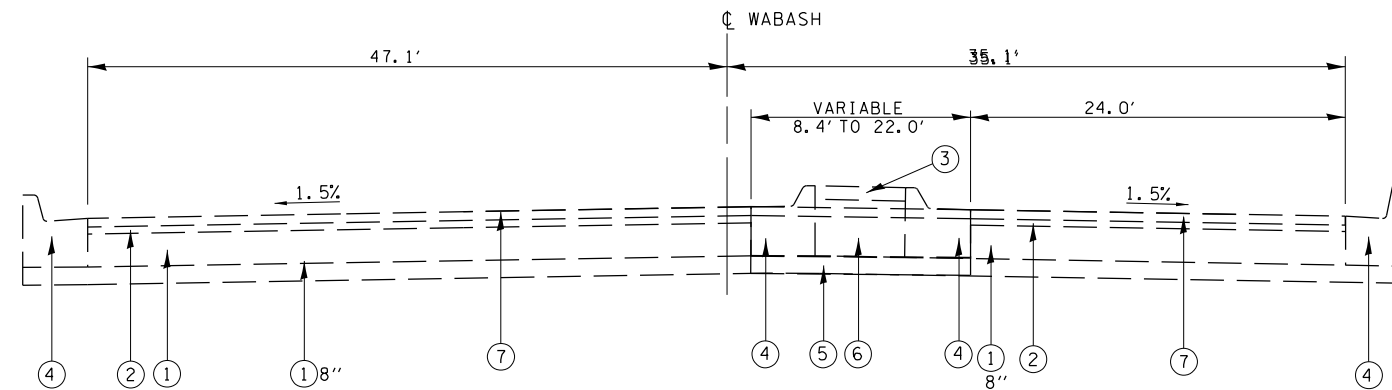

STA 548+46 TO STA 549+97

EXISTING LEGEND

- ① PCC PAVEMENT
- ② HMA SURFACE, 3 1/2" MINIMUM & VARIABLE
- ③ CONCRETE MEDIAN
- ④ CURB & GUTTER
- ⑤ SUB-BASE GRANULAR MATERIAL, TY B (DEPTH = 4")
- ⑥ BASE COURSE (OPTION), (10 1/2" DEPTH)
- ⑦ HMA SURFACE, 1 1/2"
- ⑧ PAVEMENT MARKING 5"
- ⑨ COMBINATION CONCRETE CURB & GUTTER, TYP B-6.24
- ⑩ CONCRETE MEDIAN SURFACE, 4"

MODEL: Default
 FILE NAME: p:\project-aw-bee\paw.com\FW\DOT\Documents\DOT Office\District 6\Project\0672N10\CADD\03_5510\CADD\sheet\0672N10\sheet\typical.dgn

USER NAME = sotelof	DESIGNED -	REVISED -
	DRAWN -	REVISED -
PLOT SCALE = 100,0000' / in.	CHECKED -	REVISED -
PLOT DATE = 10/25/2021	DATE -	REVISED -

**STATE OF ILLINOIS
DEPARTMENT OF TRANSPORTATION**

TYPICAL CROSS SECTIONS WABASH			
SCALE:	SHEET	OF	SHEETS
	STA.	TO	STA.

F.A.P. RTE.	SECTION	COUNTY	TOTAL SHEETS	SHEET NO.
662	(21RS-10, G-RS16) PP	SANGAMON	32	9
CONTRACT NO. 72N10				
ILLINOIS FED. AID PROJECT				

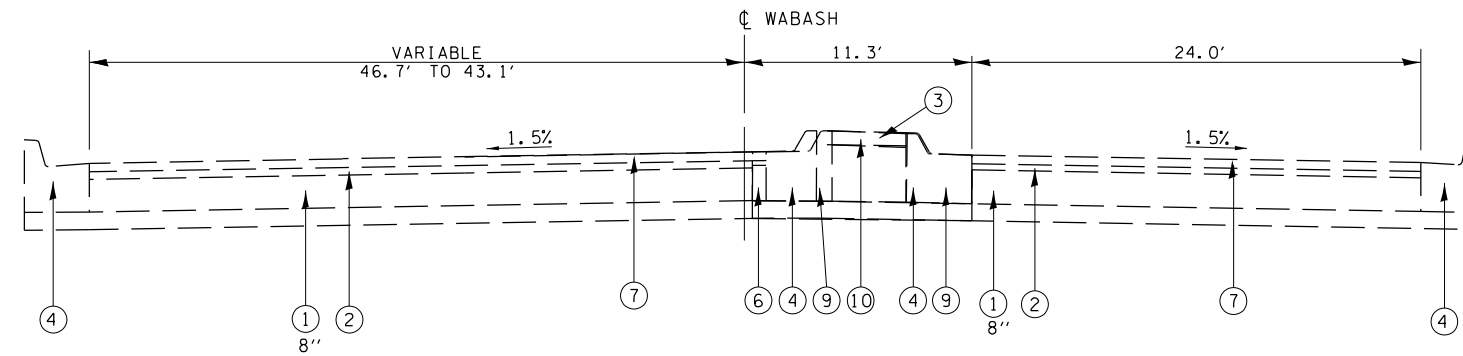

STA 549+97 TO STA 550+53

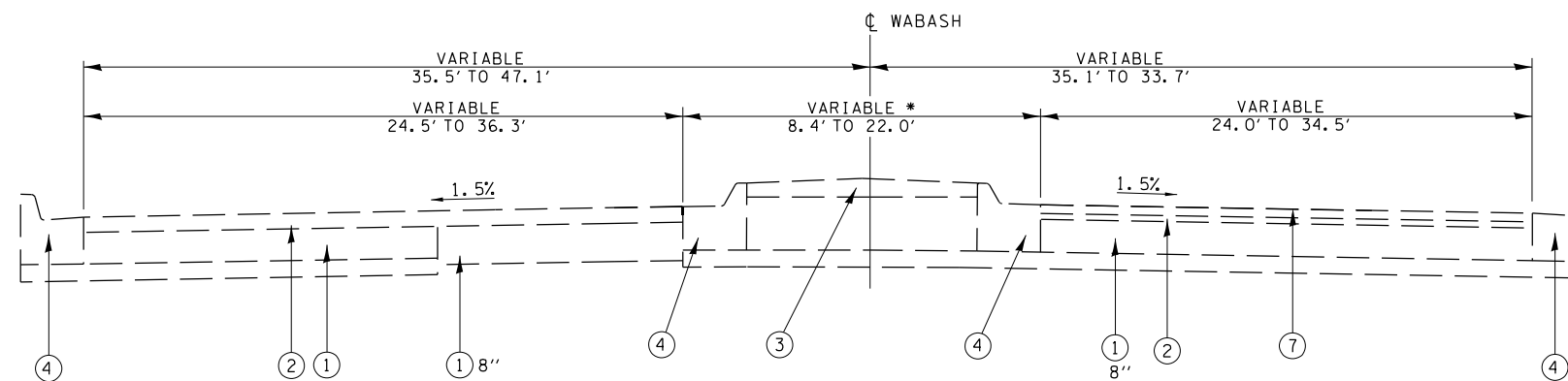

STA 550+53 TO STA 554+99.18
STATION EQUATION:
STA 554+99.18 (BK) = STA. 555+00.00 (AHD)
STA 555+00 TO STA 559+90

* - EXISTING RAISED CONCRETE MEDIAN
 SHIFTS FROM RIGHT TO LEFT OF CENTERLINE
 STA. 550+53.1 TO 559+37.5

EXISTING LEGEND

- ① PCC PAVEMENT
- ② HMA SURFACE, 3 1/2" MINIMUM & VARIABLE
- ③ CONCRETE MEDIAN
- ④ CURB & GUTTER
- ⑤ SUB-BASE GRANULAR MATERIAL, TY B (DEPTH = 4")
- ⑥ BASE COURSE (OPTION), (10 1/2" DEPTH)
- ⑦ HMA SURFACE, 1 1/2"
- ⑧ PAVEMENT MARKING 5"
- ⑨ COMBINATION CONCRETE CURB & GUTTER, TYP B-6.24
- ⑩ CONCRETE MEDIAN SURFACE, 4"

MODEL: Default
 FILE NAME: p:\project-aw-beadefy.com\PIV\DOT\Documents\DOT Office\Director_E\Project\0672N10\CADD\DATA_5510\CADD\beadefy\0672N10\csttypical.dgn

USER NAME = sotelof	DESIGNED -	REVISED -
	DRAWN -	REVISED -
PLOT SCALE = 100,0000' / in.	CHECKED -	REVISED -
PLOT DATE = 10/25/2021	DATE -	REVISED -

**STATE OF ILLINOIS
 DEPARTMENT OF TRANSPORTATION**

TYPICAL CROSS SECTIONS WABASH	
SCALE:	SHEET OF SHEETS STA. TO STA.

F.A.P. RTE.	SECTION	COUNTY	TOTAL SHEETS	SHEET NO.
662	(21RS-10, G-RS16) PP	SANGAMON	32	10
CONTRACT NO. 72N10				
ILLINOIS FED. AID PROJECT				

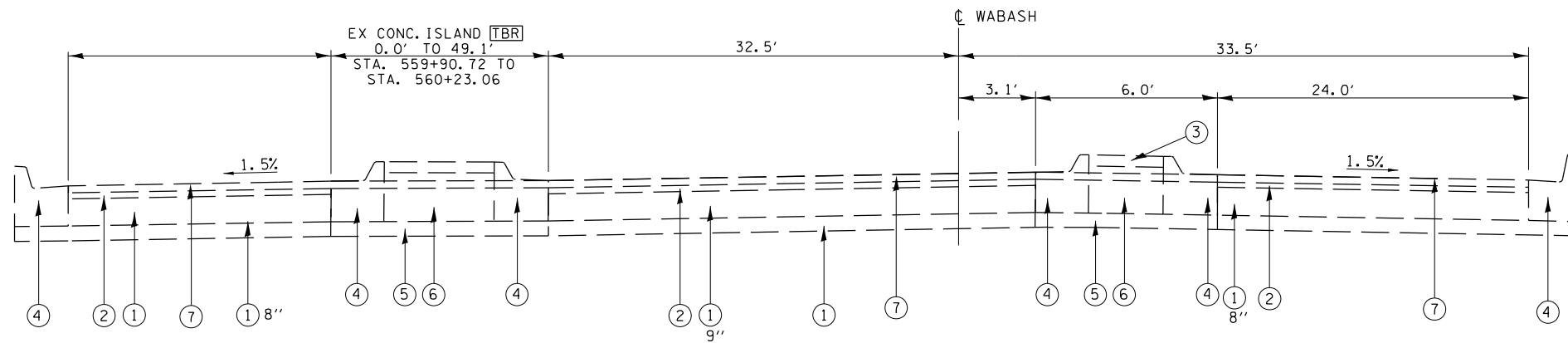

STA 559+90 TO STA 561+22

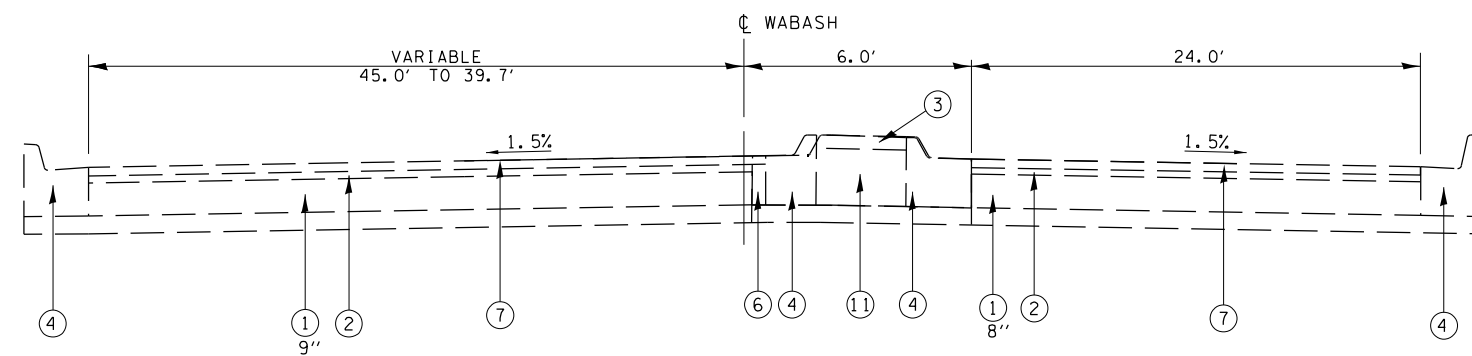

STA 561+22 TO STA 562+69

EXISTING LEGEND

- ① PCC PAVEMENT
- ② HMA SURFACE, 3 1/2" MINIMUM & VARIABLE
- ③ CONCRETE MEDIAN
- ④ CURB & GUTTER
- ⑤ SUB-BASE GRANULAR MATERIAL, TY B (DEPTH = 4")
- ⑥ BASE COURSE (OPTION), (10 1/2" DEPTH)
- ⑦ HMA SURFACE, 1 1/2"
- ⑧ PAVEMENT MARKING 5"
- ⑨ COMBINATION CONCRETE CURB & GUTTER, TYP B-6.24
- ⑩ CONCRETE MEDIAN SURFACE, 4"
- ⑪ CONCRETE MEDIAN, TYPE B-6.24

MODEL: Default
 FILE NAME: p:\ultra-cw-bee-fwy.com\FWIDOT\Documents\DOT Office\Director_E\Project\0672N10\CADD\DATA_5510\CADD\sheet\0672N10\sheet\typical.dgn

USER NAME = sotelof	DESIGNED -	REVISED -
	DRAWN -	REVISED -
PLOT SCALE = 100,0000' / in.	CHECKED -	REVISED -
PLOT DATE = 10/25/2021	DATE -	REVISED -

**STATE OF ILLINOIS
DEPARTMENT OF TRANSPORTATION**

TYPICAL CROSS SECTIONS WABASH		F.A.P. RTE.	SECTION	COUNTY	TOTAL SHEETS	SHEET NO.
		662	(21RS-10, G-RS16) PP	SANGAMON	32	11
SCALE:	SHEET OF SHEETS	STA.	TO STA.			

F.A.P. RTE.	SECTION	COUNTY	TOTAL SHEETS	SHEET NO.
662	(21RS-10, G-RS16) PP	SANGAMON	32	11
CONTRACT NO. 72N10				
ILLINOIS FED. AID PROJECT				

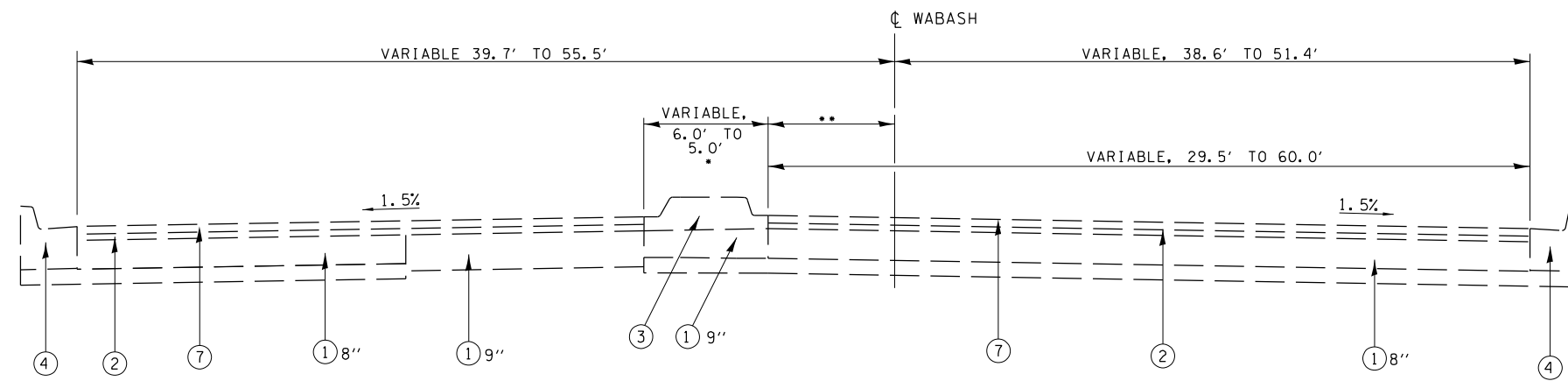

STA 562+69 TO STA 568+70

- EXISTING RAISED CONCRETE MEDIAN SHIFTS RIGHT TO LEFT OF CENTERLINE STA. 562+69 TO STA. 564+11
- *** VARIABLE, 0.0' TO 8.5' @ :
STA. 564+11 TO 565+61.20
8.5' @ :
STA. 565+61.20 TO 567+58.75

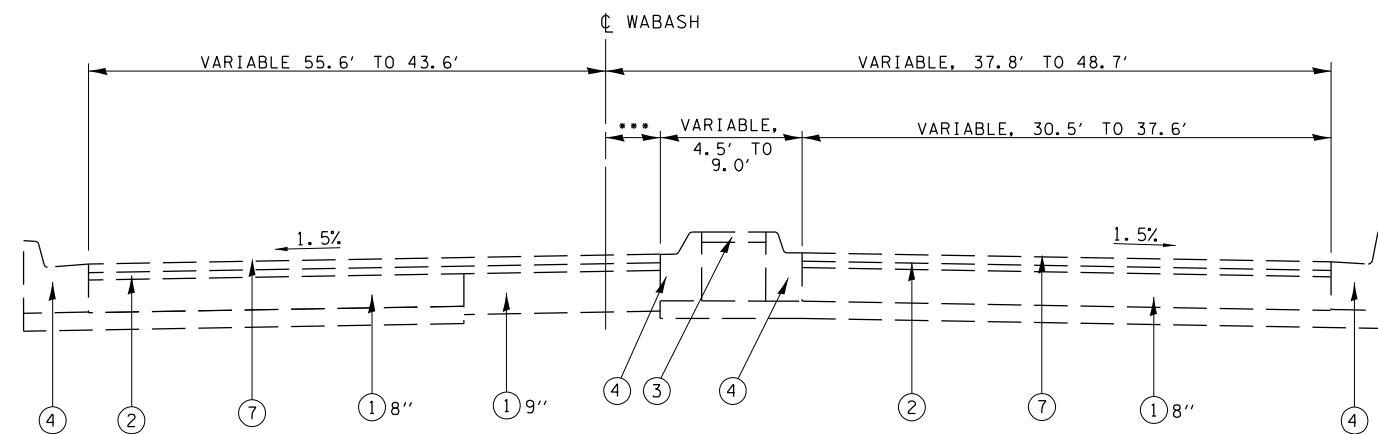

STA 568+70 TO STA 572+99

- **** 4.4' @ :
STA. 569+43.90 TO 572+35.04
VARIABLE, 4.4' TO 0.0' @ :
STA. 572+35.04 TO STA. 572+98.85

EXISTING LEGEND

- ① PCC PAVEMENT
- ② HMA SURFACE, 3 1/2" MINIMUM & VARIABLE
- ③ CONCRETE MEDIAN
- ④ CURB & GUTTER
- ⑤ SUB-BASE GRANULAR MATERIAL, TY B (DEPTH = 4")
- ⑥ BASE COURSE (OPTION), (10 1/2" DEPTH)
- ⑦ HMA SURFACE, 1 1/2"
- ⑧ PAVEMENT MARKING 5"
- ⑨ COMBINATION CONCRETE CURB & GUTTER, TYP B-6.24
- ⑩ CONCRETE MEDIAN SURFACE, 4"

MODEL: Default
 FILE NAME: p:\ultra-cad-beadefy.com\FW\DOT\Documents\DOT_offices\Dir\drct_6\Project\0672N10\CAD\DATA_5510\CAD\beadefy\0672N10\ultra-cad-beadefy.dgn

USER NAME = sotelof	DESIGNED -	REVISED -
	DRAWN -	REVISED -
PLOT SCALE = 100,0000' / in.	CHECKED -	REVISED -
PLOT DATE = 10/25/2021	DATE -	REVISED -

**STATE OF ILLINOIS
DEPARTMENT OF TRANSPORTATION**

TYPICAL CROSS SECTIONS WABASH			
SCALE:	SHEET	OF	SHEETS
	STA.	TO	STA.

F.A.P. RTE.	SECTION	COUNTY	TOTAL SHEETS	SHEET NO.
662	(21RS-10, G-RS16) PP	SANGAMON	32	12
			CONTRACT NO. 72N10	
		ILLINOIS FED. AID PROJECT		

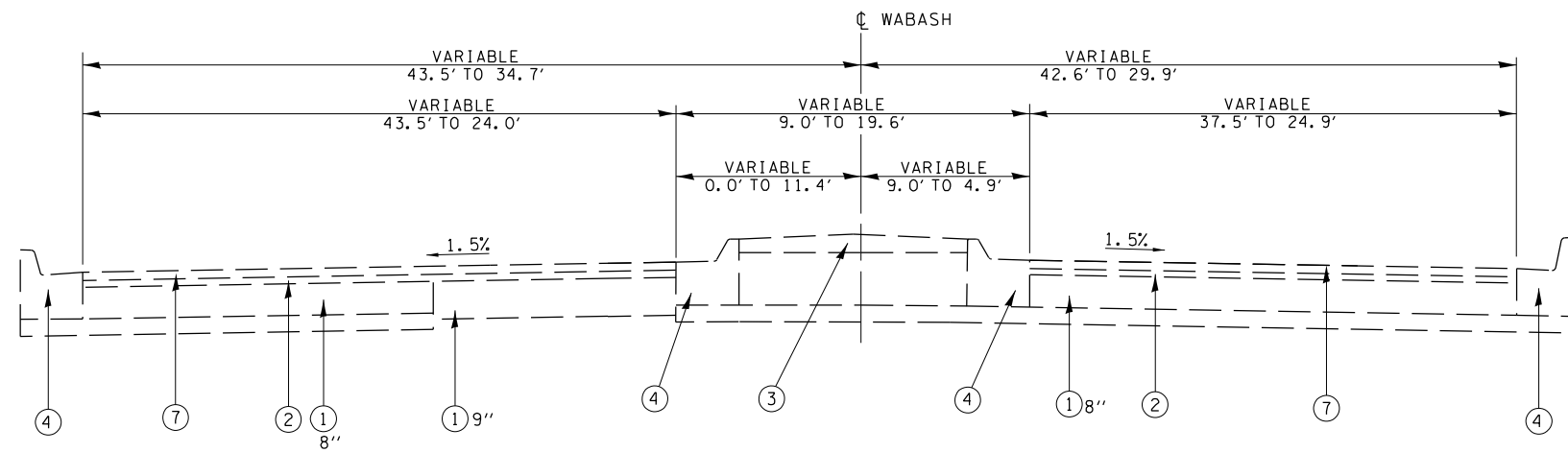

STA 572+99 TO STA 575+00

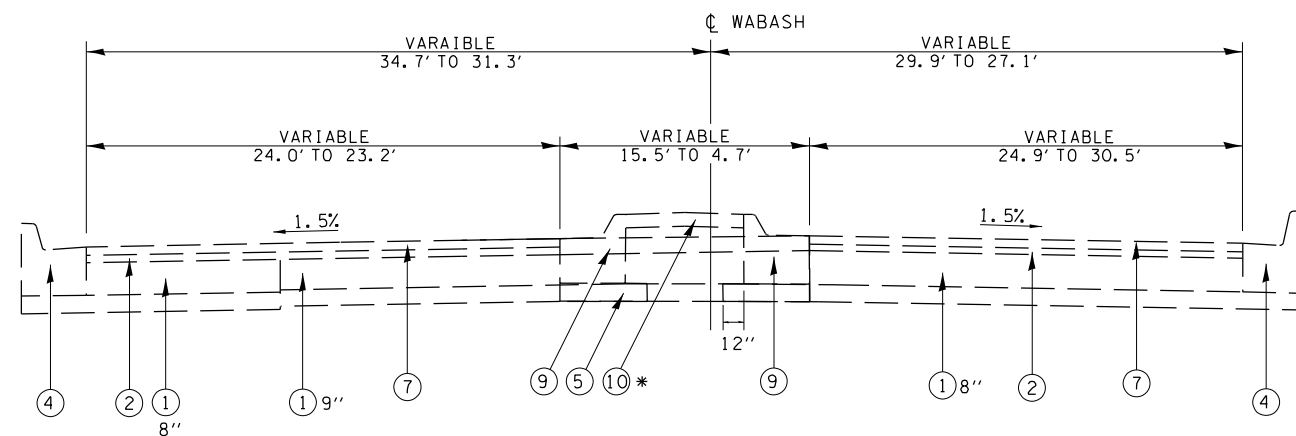

STA 575+00 TO STA 575+89

EXISTING LEGEND

- ① PCC PAVEMENT
- ② HMA SURFACE, 3 1/2" MINIMUM & VARIABLE
- ③ CONCRETE MEDIAN
- ④ CURB & GUTTER
- ⑤ SUB-BASE GRANULAR MATERIAL, TY B (DEPTH = 4")
- ⑥ BASE COURSE (OPTION), (10 1/2" DEPTH)
- ⑦ HMA SURFACE, 1 1/2"
- ⑧ PAVEMENT MARKING 5"
- ⑨ COMBINATION CONCRETE CURB & GUTTER, TYP B-6.24
- ⑩ CONCRETE MEDIAN SURFACE, 4" *

MODEL: Default
 FILE NAME: p:\project-aw-beadby.com\p\id\DOT\Documents\DOT\Office\Director\Project\0672N10\CAD\DATA_S5\10\CAD\sheet\0672N10\sheet\typical.dwg

USER NAME = sotelof	DESIGNED -	REVISED -
	DRAWN -	REVISED -
PLOT SCALE = 100,0000' / in.	CHECKED -	REVISED -
PLOT DATE = 10/25/2021	DATE -	REVISED -

**STATE OF ILLINOIS
DEPARTMENT OF TRANSPORTATION**

TYPICAL CROSS SECTIONS WABASH		SCALE:	SHEET	OF	SHEETS	STA.	TO	STA.

F.A.P. RTE.	SECTION	COUNTY	TOTAL SHEETS	SHEET NO.
662	(21RS-10, G-R516) PP	SANGAMON	32	13
CONTRACT NO. 72N10				
ILLINOIS FED. AID PROJECT				

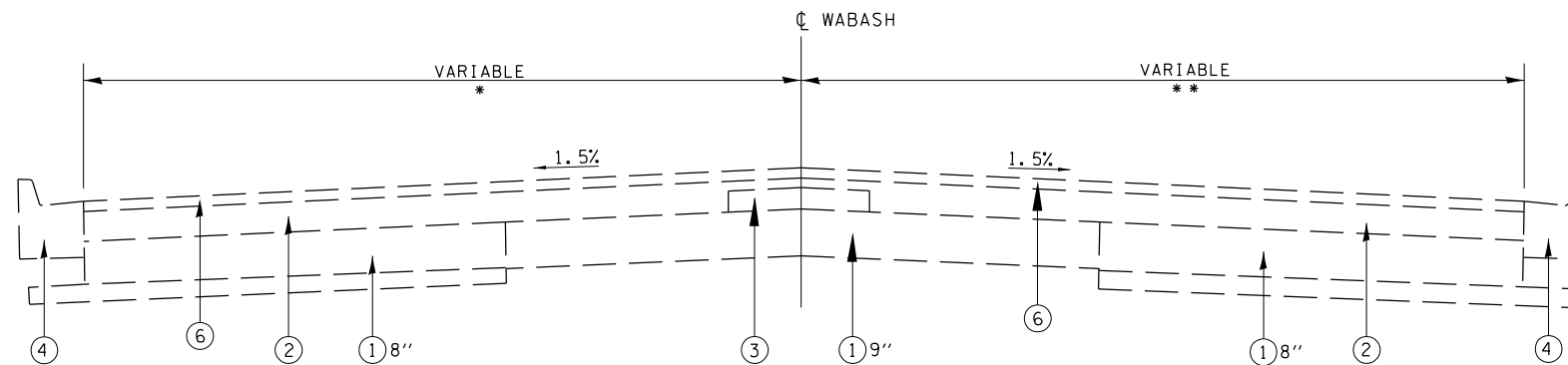

* -	LOCATION	LEFT
	STA 576+00	31.3'
	STA 579+00	25.2'
	STA 582+74	25.4'
	STA 587+00	25.4'
	STA 592+00	25.2'
	STA 597+00	25.1'
	STA 602+00	26.0'
	STA 602+65	26.0'

STA 575+89 TO STA 577+99.99
 STATION EQUATION:
 STA 577+99.99 (BK) = STA. 578+00.00 (AHD)
 STA 578+00.00 TO STA 602+65.50

** -	LOCATION	LEFT
	STA 576+00	26.7'
	STA 579+00	26.6'
	STA 582+74	26.1'
	STA 584+80	36.6'
	STA 586+66	36.0'
	STA 587+00	26.1'
	STA 592+00	26.5'
	STA 597+00	26.7'
	STA 602+00	26.2'
	STA 602+65	26.8'

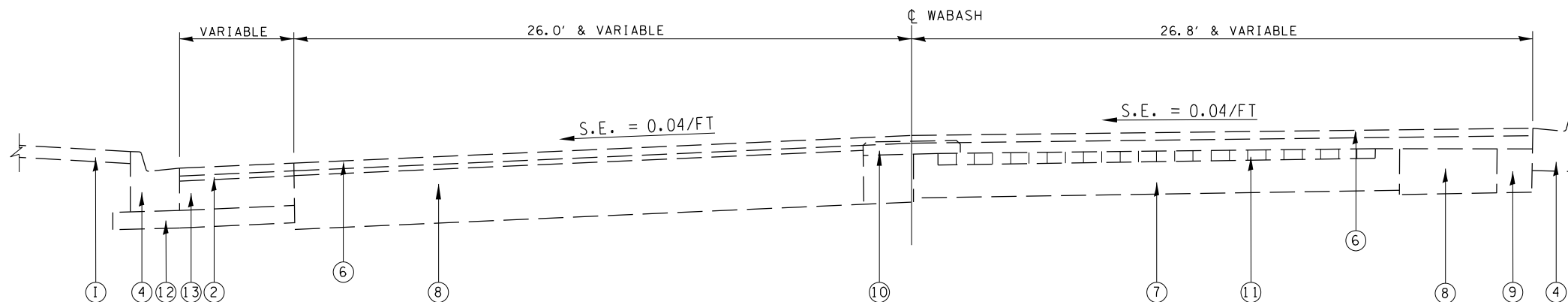

STA 602+65.50 TO STA 603+08.51
 STATION EQUATION:
 STA 603+08.51 (BK) = STA. 83+28.31 (AHD)
 STA 83+28.31 TO STA 85+03.75

EXISTING LEGEND

- | | |
|--------------------------------------------------|-------------------------------------------------|
| ① PCC PAVEMENT | ⑫ SUB-BASE GRANULAR MATERIAL, TY B (DEPTH = 4") |
| ② HMA SURFACE, 3 1/2" AND VARIABLE | ⑬ BASE COURSE (OPTION), (10 1/2" DEPTH) |
| ③ CONCRETE MEDIAN | ⑭ ITEM OMITTED |
| ④ COMBINATION CONCRETE CURB & GUTTER, TYP B-6.24 | ⑮ PAVEMENT MARKING 5" |
| ⑤ PIPE UNDERDRAINS | ⑯ CONCRETE MEDIAN SURFACE, 4" |
| ⑥ HMA SURFACE, 1 1/2" | ⑰ INCIDENTAL HMA SURFACING, 3" DEPTH |
| ⑦ PCC BASE COURSE +/- 7" | |
| ⑧ PCC BASE COURSE, 9" | |
| ⑨ PCC BASE COURSE WIDENING, 9" | |
| ⑩ PCC MEDIAN, TYPE C-4 (MODIFIED) | |
| ⑪ BRICK PAVEMENT 2 1/2" | |

MODEL: Default
 FILE NAME: p:\project\paw\beadefy.com\FW\DOT\Documents\DOT Office\Dir\drct. E:\Project\0672N10\CADD\DATA_5510\CADD\beadefy\0672N10\beadefy\cal.dgn

USER NAME = sotelof	DESIGNED -	REVISED -
	DRAWN -	REVISED -
PLOT SCALE = 100,0000' / in.	CHECKED -	REVISED -
PLOT DATE = 10/25/2021	DATE -	REVISED -

**STATE OF ILLINOIS
 DEPARTMENT OF TRANSPORTATION**

TYPICAL CROSS SECTIONS WABASH			
SCALE:	SHEET	OF	SHEETS

F.A.P. RTE.	SECTION	COUNTY	TOTAL SHEETS	SHEET NO.
662	(21RS-10, G-R516) PP	SANGAMON	32	14
CONTRACT NO. 72N10				
ILLINOIS FED. AID PROJECT				

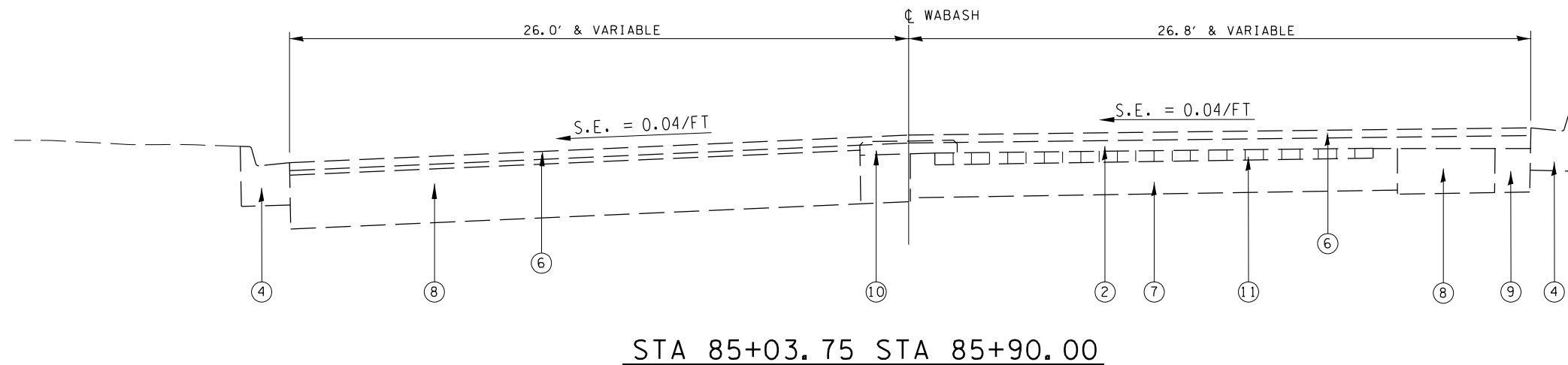

EXISTING LEGEND

- | | |
|-------------------------------------------------------------------------------------------------------------------------------------------------------------------------------------------------------------------------------------------------------------------------------------------------------------------------------------------------------------------------------------------------------------------------------------------------------|------------------------------------------------------------------------------------------------------------------------------------------------------------------------------------------------------------------------------------------------------------------------------------------------|
| <ul style="list-style-type: none"> ① PCC PAVEMENT ② HMA SURFACE, 3 1/2" AND VARIABLE ③ CONCRETE MEDIAN ④ COMBINATION CONCRETE CURB & GUTTER, TYP B-6.24 ⑤ PIPE UNDERDRAINS ⑥ HMA SURFACE, 1 1/2" ⑦ PCC BASE COURSE +/- 7" ⑧ PCC BASE COURSE, 9" ⑨ PCC BASE COURSE WIDENING, 9" ⑩ PCC MEDIAN, TYPE C-4 (MODIFIED) ⑪ BRICK PAVEMENT 2 1/2" | <ul style="list-style-type: none"> ⑫ SUB-BASE GRANULAR MATERIAL, TY B (DEPTH = 4") ⑬ BASE COURSE (OPTION), (10 1/2" DEPTH) ⑭ ITEM OMITTED ⑮ PAVEMENT MARKING 5" ⑯ CONCRETE MEDIAN SURFACE, 4" ⑰ INCIDENTAL HMA SURFACING, 3" DEPTH |
|-------------------------------------------------------------------------------------------------------------------------------------------------------------------------------------------------------------------------------------------------------------------------------------------------------------------------------------------------------------------------------------------------------------------------------------------------------|------------------------------------------------------------------------------------------------------------------------------------------------------------------------------------------------------------------------------------------------------------------------------------------------|

MODEL: Default
 FILE NAME: p:\ultra-cw-bead-fy.com\PIV\DOT\Documents\DOT Office\District 6\Project\0672N10\CAD\DATA_5510\CAD\sheet\0672N10\sheet\typical.dgn

USER NAME = sotelof	DESIGNED -	REVISED -
	DRAWN -	REVISED -
PLOT SCALE = 100,0000' / in.	CHECKED -	REVISED -
PLOT DATE = 10/25/2021	DATE -	REVISED -

**STATE OF ILLINOIS
DEPARTMENT OF TRANSPORTATION**

**TYPICAL CROSS SECTIONS
WABASH**

SCALE: SHEET OF SHEETS STA. TO STA.

F.A.P. RTE.	SECTION	COUNTY	TOTAL SHEETS	SHEET NO.
662	(21RS-10, G-RS16) PP	SANGAMON	32	15
CONTRACT NO. 72N10				
ILLINOIS FED. AID PROJECT				

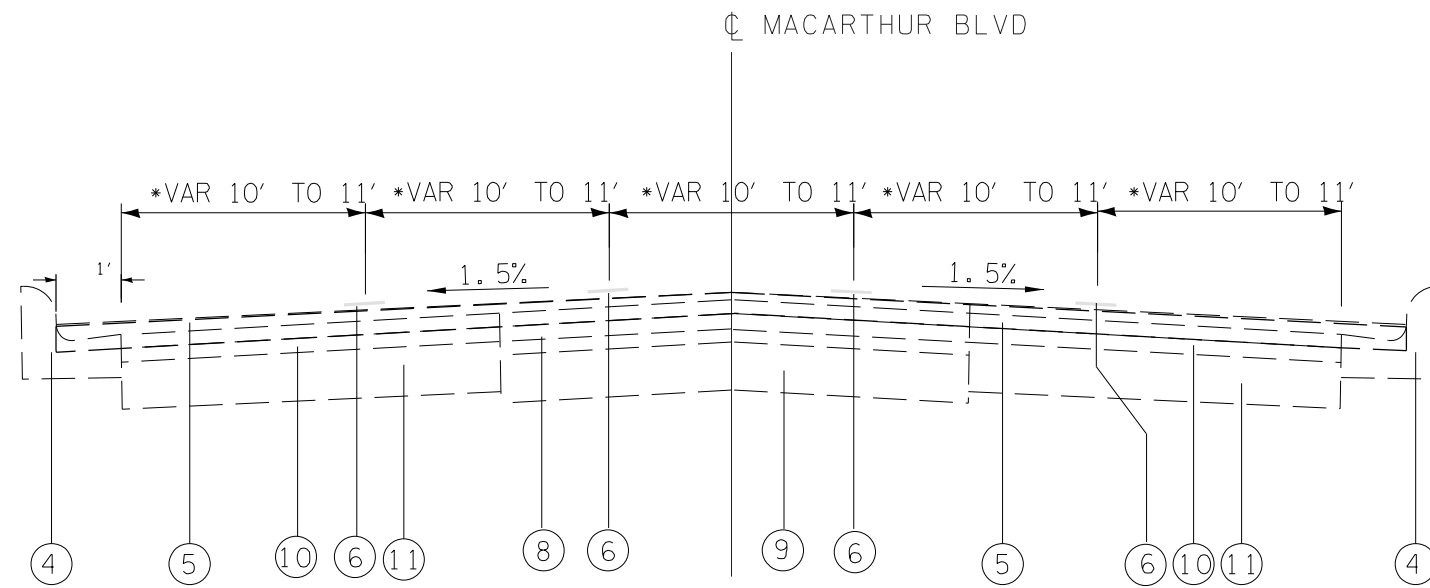

TYPICAL SECTION - MACARTHUR BLVD

NOT TO SCALE

* STA 639+27 TO STA 649+53
STA 660+36 TO STA 663+36

LEGEND

- ① EXISTING PCC PAVEMENT 9" WITH BITUMINOUS SURFACE COURSE 1/2"
- ② EXISTING PCC BASE COURSE WIDENING 8" WITH BITUMINOUS SURFACE COURSE 1/2"
- ③ EXISTING CONCRETE MEDIAN
- ④ EXISTING CONCRETE CURB AND GUTTER
- ⑤ POLYMERIZED BITUMINOUS CONCRETE SURFACE COURSE, SUPERPAVE, MIX E, N90, 2"
- ⑥ EXISTING PAVEMENT MARKING - LINE 5"
- ⑦ EXISTING BITUMINOUS BASE COURSE WITH BITUMINOUS SURFACE COURSE
- ⑧ EXISTING BRICK
- ⑨ EXISTING PCC PAVEMENT 9"-6"-9"
- ⑩ EXISTING BITUMINOUS CONCRETE, VARIABLE DEPTH
- ⑪ EXISTING PCC BASE COURSE
- ⑫ EXISTING SAND CUSHION
- ⑬ EXISTING BITUMINOUS CONCRETE VARIABLE DEPTH

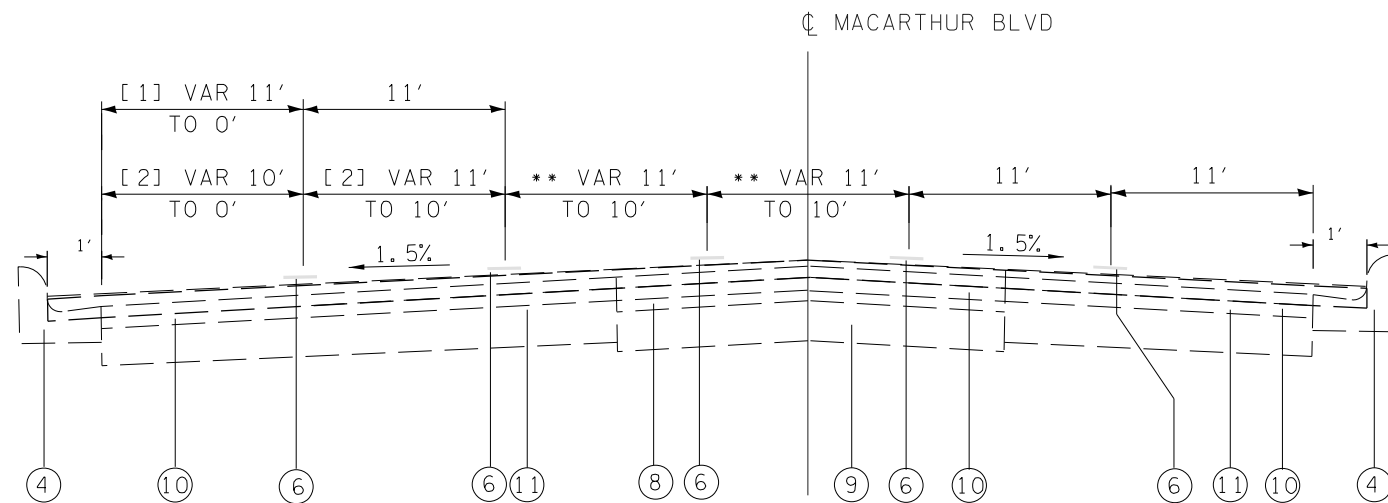

TYPICAL SECTION - MACARTHUR BLVD

NOT TO SCALE

STA 649+53 TO STA 662+82
** STA 658+84 TO STA 659+60
[1] STA 649+53 TO STA 652+65
[1] STA 656+34 TO STA 659+60
[2] STA 659+60 TO STA 662+10

MODEL: Default
 FILE NAME: p:\project-aw-beadby.com\FW\DOT\Documents\DOT Office\Districts\Project\0672N10\CADD\DATA_S51\0\CADD\beadby\0672N10\sect-typical.dgn

USER NAME = sotelof	DESIGNED -	REVISED -
	DRAWN -	REVISED -
PLOT SCALE = 100,0000' / in.	CHECKED -	REVISED -
PLOT DATE = 10/25/2021	DATE -	REVISED -

**STATE OF ILLINOIS
DEPARTMENT OF TRANSPORTATION**

TYPICAL CROSS SECTIONS MACARTHUR		F.A.P. RTE.	SECTION	COUNTY	TOTAL SHEETS	SHEET NO.
		662	(21RS-10, G-RS16) PP	SANGAMON	32	16
SCALE:	SHEET	OF	SHEETS	STA.	TO	STA.

ILLINOIS		FED. AID PROJECT	
----------	--	------------------	--

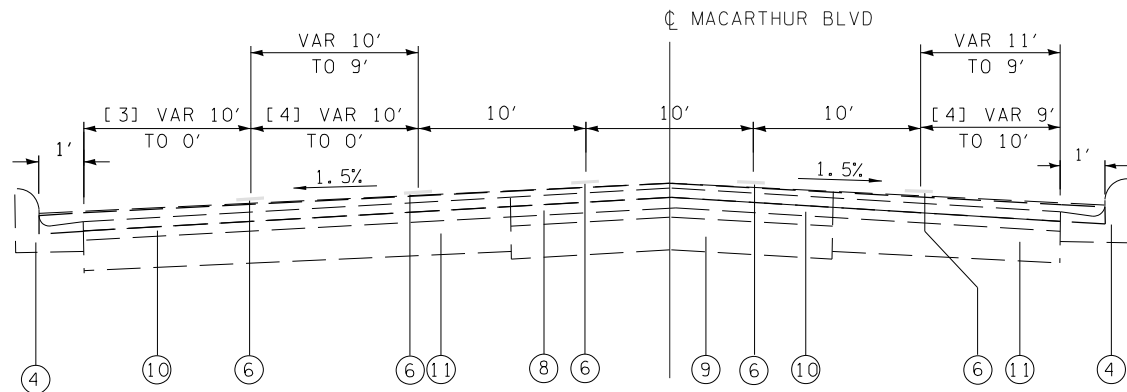

TYPICAL SECTION - MACARTHUR BLVD

NOT TO SCALE

STA 662+82 TO STA 684+70
 [3] STA 662+82 TO STA 665+70
 [4] STA 665+70 TO STA 666+52

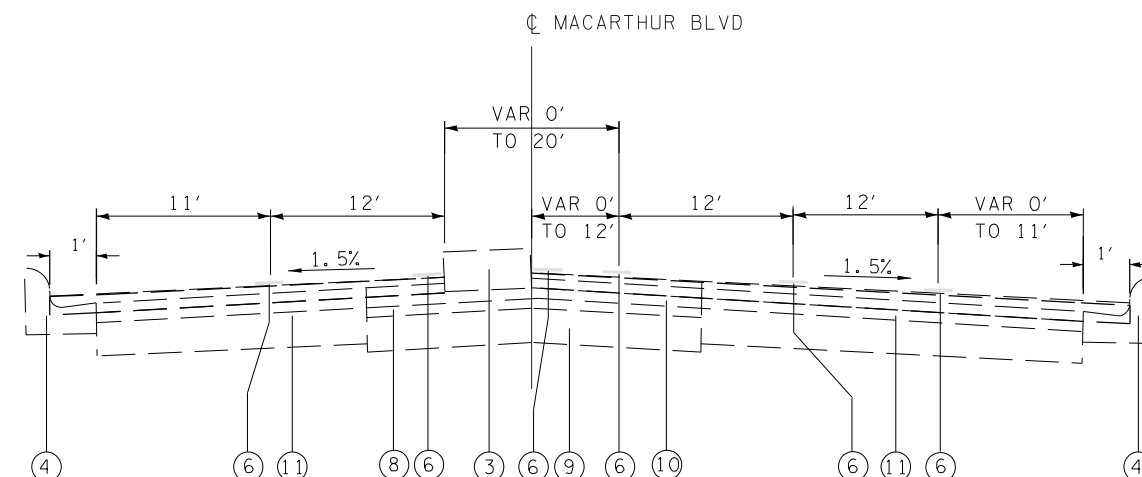

TYPICAL SECTION - MACARTHUR BLVD

NOT TO SCALE

STA 8+45 TO STA 13+52

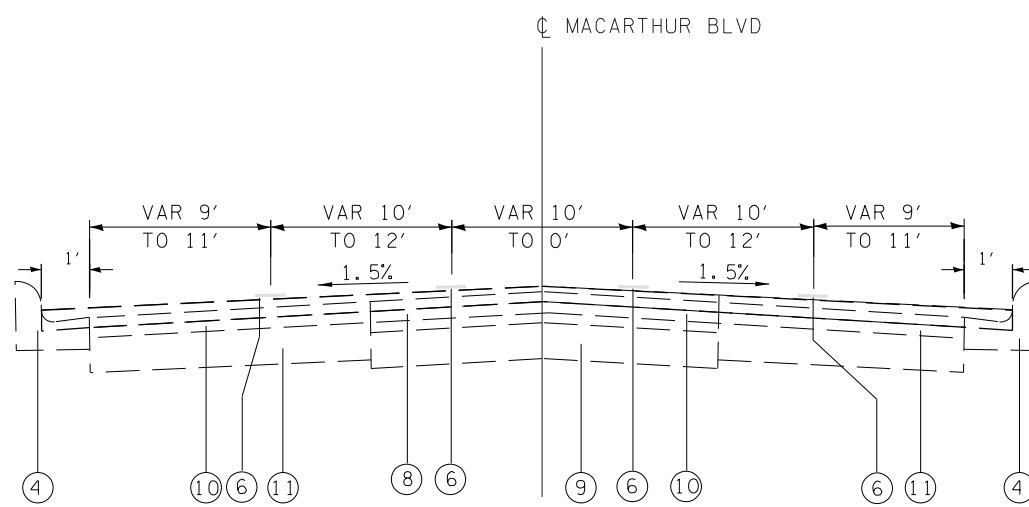

TYPICAL SECTION - MACARTHUR BLVD

NOT TO SCALE

STA 665+52 TO STA 685+50
 STA 684+70 TO STA 687+04.77 BK = STA 0+00 AH
 STA 0+00 TO STA 8+45

STA EQUATION #3 STA 687+04.77 BK =
 STA 0+00.00 AH

LEGEND

- ① EXISTING PCC PAVEMENT 9" WITH BITUMINOUS SURFACE COURSE 1 1/2"
- ② EXISTING PCC BASE COURSE WIDENING 8" WITH BITUMINOUS SURFACE COURSE 1 1/2"
- ③ EXISTING CONCRETE MEDIAN
- ④ EXISTING CONCRETE CURB AND GUTTER
- ⑤ POLYMERIZED BITUMINOUS CONCRETE SURFACE COURSE, SUPERPAVE, MIX E, N90, 2"
- ⑥ EXISTING PAVEMENT MARKING - LINE 5"
- ⑦ EXISTING BITUMINOUS BASE COURSE WITH BITUMINOUS SURFACE COURSE
- ⑧ EXISTING BRICK
- ⑨ EXISTING PCC PAVEMENT 9"-6"-9"
- ⑩ EXISTING BITUMINOUS CONCRETE, VARIABLE DEPTH
- ⑪ EXISTING PCC BASE COURSE
- ⑫ EXISTING SAND CUSHION
- ⑬ EXISTING BITUMINOUS CONCRETE VARIABLE DEPTH

MODEL: Default
 FILE NAME: p:\project-caw-beadley.com\FW\DOT\Documents\DOT Offsets\Drawings\Project\0672N10\CAD\Drawings\0672N10\Sheet\Typical.dwg

USER NAME = sotelof	DESIGNED -	REVISED -
	DRAWN -	REVISED -
PLOT SCALE = 100,0000' / in.	CHECKED -	REVISED -
PLOT DATE = 10/25/2021	DATE -	REVISED -

**STATE OF ILLINOIS
 DEPARTMENT OF TRANSPORTATION**

**TYPICAL CROSS SECTIONS
 MACARTHUR**

SCALE: SHEET OF SHEETS STA. TO STA.

F.A.P. RTE.	SECTION	COUNTY	TOTAL SHEETS	SHEET NO.
662	(21RS-10, G-RS16) PP	SANGAMON	32	17
CONTRACT NO. 72N10				
ILLINOIS FED. AID PROJECT				

**BEGINNING
OF PROJECT
STA 492+79.38**

MATCH LINE STA 484+00.00

MATCH LINE STA 498+00.00

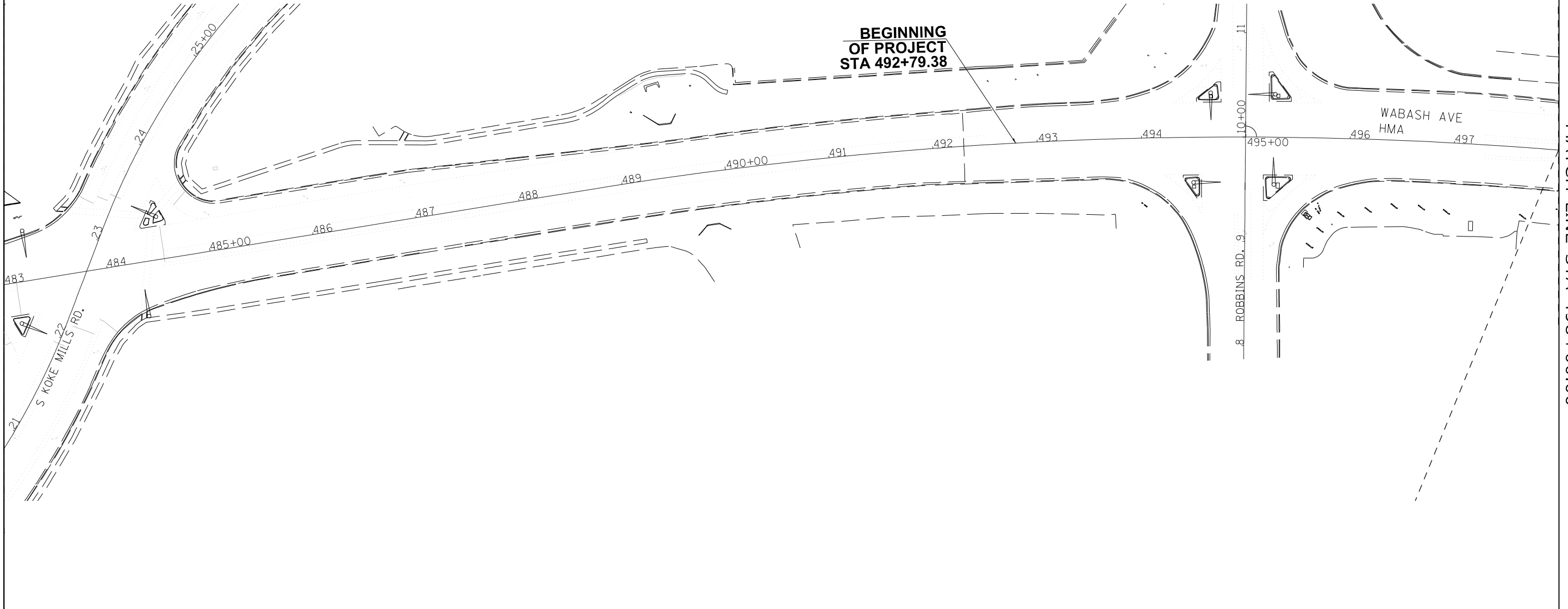

-  **CLASS C PATCHING**
-  **PARTIAL DEPTH PATCHING – 2"**
-  **LONGITUDINAL JOINT AND CRACK PATCHING**

MODEL: Default
 FILE NAME: p:\project-pw-beachy.com\p\72N10\Documents\DOT Office\Drawings\72N10\CADD\Drawings\72N10\72N10-10-10.dwg
 PROJECT: 72N10

USER NAME = sotelof	DESIGNED -	REVISED -
PLOT SCALE = 100,0000' / in.	DRAWN -	REVISED -
PLOT DATE = 10/25/2021	CHECKED -	REVISED -
	DATE -	REVISED -

**STATE OF ILLINOIS
DEPARTMENT OF TRANSPORTATION**

**PLAN SHEETS
WABASH**



SCALE: SHEET 7 OF 15 SHEETS STA. TO STA.

F.A.P. RTE.	SECTION	COUNTY	TOTAL SHEETS	SHEET NO.
664	(21RS-10, G-RS-16) PP	SANGAMON	32	18
CONTRACT NO. 72N10			ILLINOIS FED. AID PROJECT	

MATCH LINE STA 498+00.00

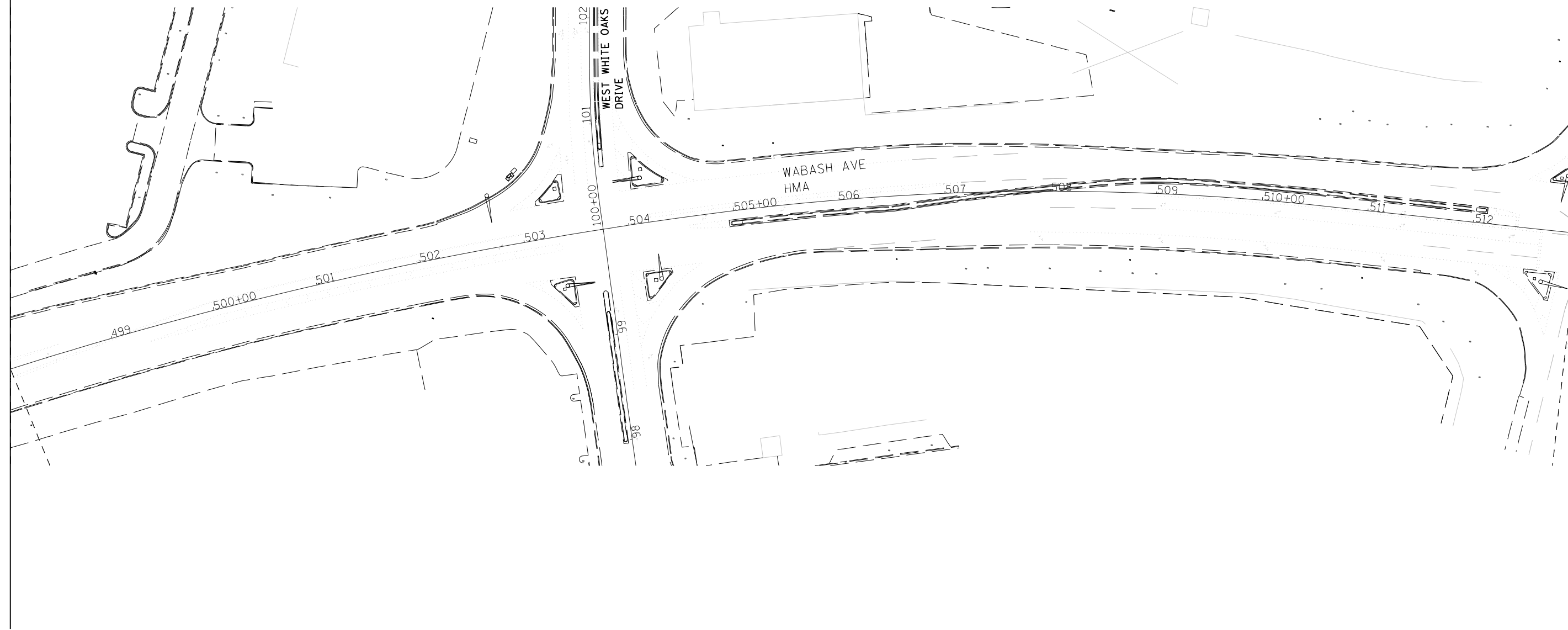
MATCH LINE STA 513+00.00



-  CLASS C PATCHING
-  PARTIAL DEPTH PATCHING - 2"
-  LONGITUDINAL JOINT AND CRACK PATCHING

USER NAME = sotelof	DESIGNED -	REVISED -
	DRAWN -	REVISED -
PLOT SCALE = 100,0000' / in.	CHECKED -	REVISED -
PLOT DATE = 10/25/2021	DATE -	REVISED -

**STATE OF ILLINOIS
DEPARTMENT OF TRANSPORTATION**

**PLAN SHEETS
WABASH**

SCALE: SHEET 8 OF 15 SHEETS STA. TO STA.

F.A.P. RTE.	SECTION	COUNTY	TOTAL SHEETS	SHEET NO.
664	(21RS-10, G-RS-16) PP	SANGAMON	32	19
CONTRACT NO. 72N10				
ILLINOIS FED. AID PROJECT				

MODEL: Default
 FILE NAME: p:\p\subject-pw-bee-defy.com\FW\DOT\Documents\DOT Office\Director_E\Project\0672N10\CADD\DATA_S\10\CADD\sheet\0672N10\sheet\plan.com



MATCH LINE STA 513+00.00

MATCH LINE STA 528+00.00

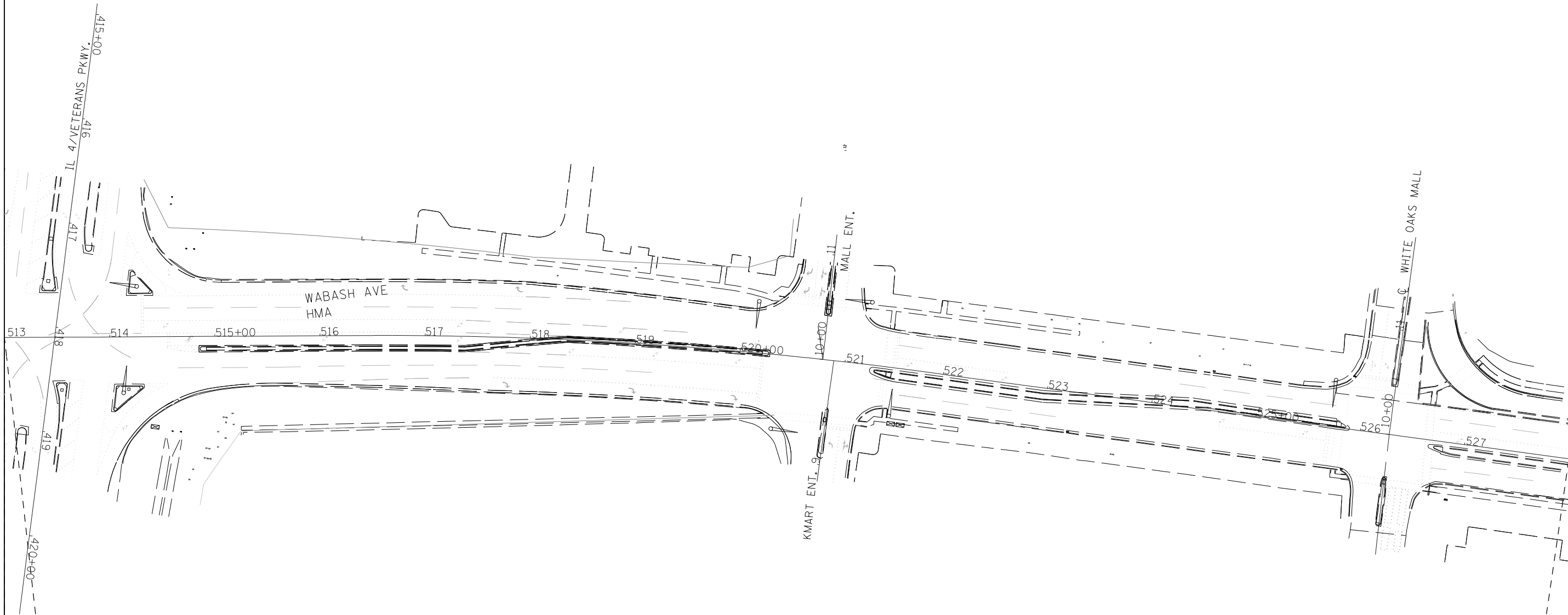

- CLASS C PATCHING**
- PARTIAL DEPTH PATCHING - 2"**
- LONGITUDINAL JOINT AND CRACK PATCHING**

MODEL: Default
 FILE NAME: p:\p\project-pw-bee-fy.com\FW\DOT\Documents\DOT Office\Dir\drf_6\Project\0672N10\060000.dwg
 PROJECT: 0672N10\060000.dwg
 PLOT DATE: 10/25/2021

USER NAME = sotelof	DESIGNED -	REVISED -
PLOT SCALE = 100,0000' / in.	DRAWN -	REVISED -
PLOT DATE = 10/25/2021	CHECKED -	REVISED -
	DATE -	REVISED -

**STATE OF ILLINOIS
DEPARTMENT OF TRANSPORTATION**

PLAN SHEETS WABASH			
SCALE:	SHEET 9	OF 15 SHEETS	STA. TO STA.



F.A.P. RTE.	SECTION	COUNTY	TOTAL SHEETS	SHEET NO.
664	(21RS-10, G-RS-16) PP	SANGAMON	32	20
CONTRACT NO. 72N10				
ILLINOIS FED. AID PROJECT				

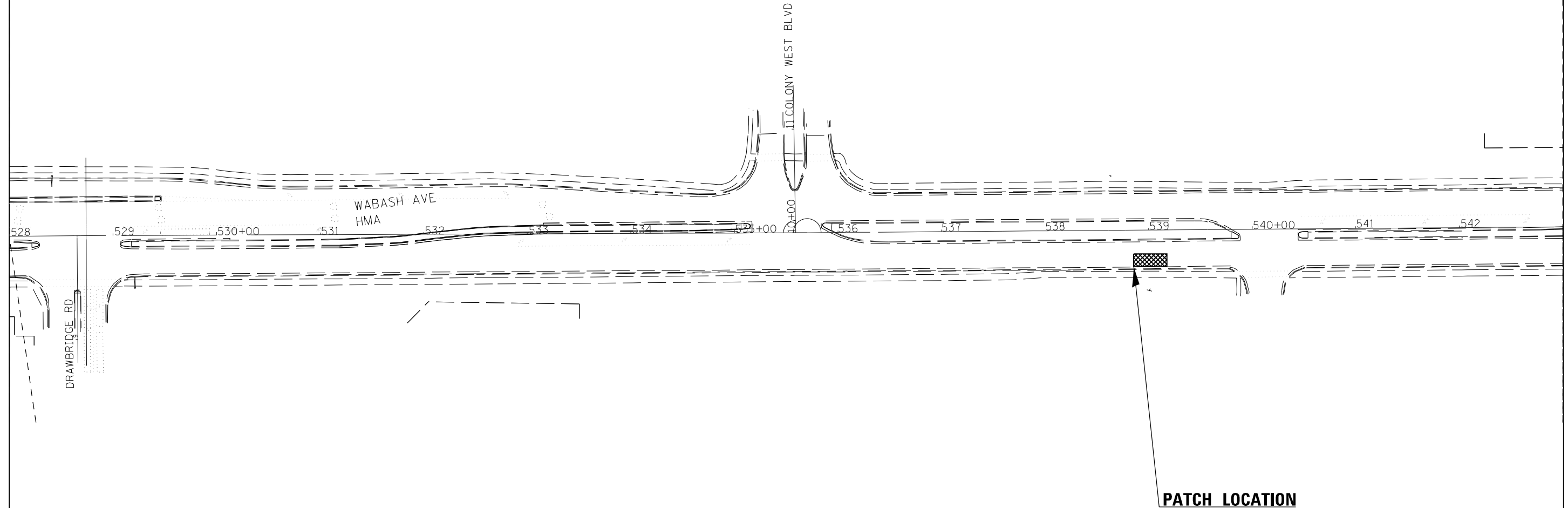

MATCH LINE STA 528+00.00

MATCH LINE STA 543+00.00



-  CLASS C PATCHING
-  PARTIAL DEPTH PATCHING - 2"
-  LONGITUDINAL JOINT AND CRACK PATCHING

USER NAME = sotelof	DESIGNED -	REVISED -
	DRAWN -	REVISED -
PLOT SCALE = 100,0000' / in.	CHECKED -	REVISED -
PLOT DATE = 10/25/2021	DATE -	REVISED -

**STATE OF ILLINOIS
DEPARTMENT OF TRANSPORTATION**

**PLAN SHEETS
WABASH**

SCALE: SHEET 10 OF 15 SHEETS STA. TO STA.

F.A.P. RTE.	SECTION	COUNTY	TOTAL SHEETS	SHEET NO.
664	(21RS-10, G-RS-16) PP	SANGAMON	32	21
CONTRACT NO. 72N10				
ILLINOIS FED. AID PROJECT				

MODEL: Default
 FILE NAME: p:\project-pw-beadby.com\p\72N10\Documents\DOT Office\Drawings\72N10\72N10-21.dwg
 PROJECT: 72N10\72N10\72N10\72N10.dwg
 PROJECT: 72N10\72N10\72N10\72N10.dwg



MATCH LINE STA 543+00.00

MATCH LINE STA 558+00.00

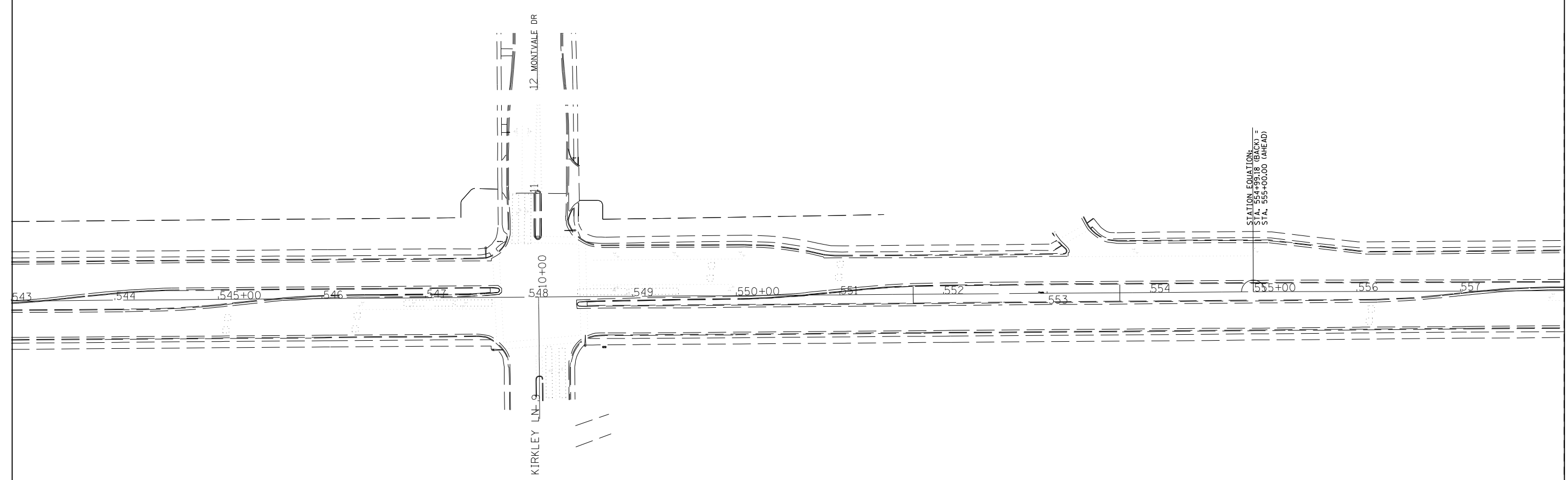

- CLASS C PATCHING**
- PARTIAL DEPTH PATCHING - 2"**
- LONGITUDINAL JOINT AND CRACK PATCHING**

MODEL: Default
 FILE NAME: p:\project-pw-beachy.com\p\w\dot\documents\DOT\offices\District 6\Project\0672N10\CADD\03_5510\CADD\sheet\0672N10\sheet\plan.com

USER NAME = sotelof	DESIGNED -	REVISED -
DRAWN -	REVISED -	
PLOT SCALE = 100,0000' / in.	CHECKED -	REVISED -
PLOT DATE = 10/25/2021	DATE -	REVISED -

**STATE OF ILLINOIS
DEPARTMENT OF TRANSPORTATION**

PLAN SHEETS WABASH			
SCALE:	SHEET 11	OF 15 SHEETS	STA. TO STA.

F.A.P. RTE.	SECTION	COUNTY	TOTAL SHEETS	SHEET NO.
664	(21RS-10, G-RS-16) PP	SANGAMON	32	22
CONTRACT NO. 72N10				
ILLINOIS FED. AID PROJECT				



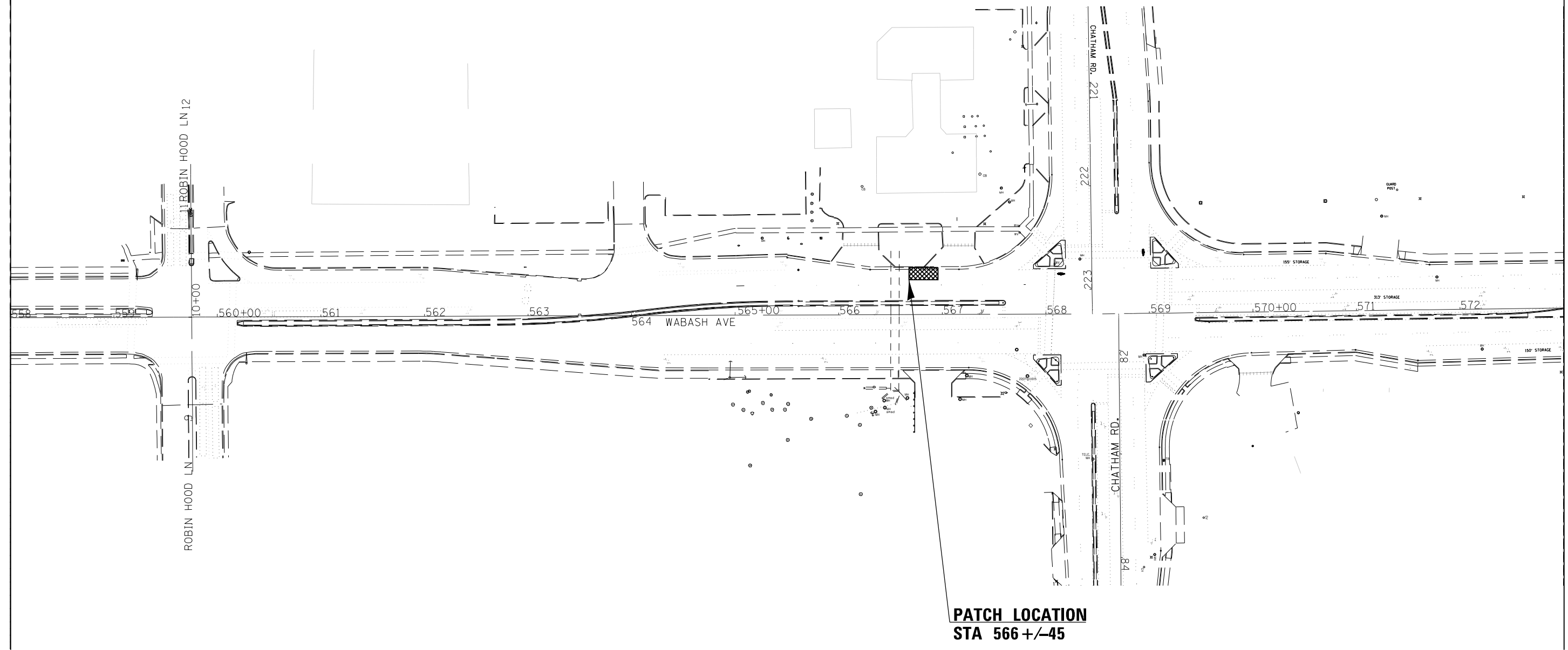

MATCH LINE STA 558+00.00

MATCH LINE STA 573+00.00



**PATCH LOCATION
STA 566 +/-45**

-  **CLASS C PATCHING**
-  **PARTIAL DEPTH PATCHING - 2"**
-  **LONGITUDINAL JOINT AND CRACK PATCHING**

MODEL: Default
FILE NAME: p:\project-pw-bee-fy.com\FW\DOT\Documents\DOT Office\Director_E\Project\0672N10\0672N10.dwg
PROJECT: 0672N10\0672N10.dwg

USER NAME = sotelof	DESIGNED -	REVISED -
PLOT SCALE = 100,0000 ' / in.	DRAWN -	REVISED -
PLOT DATE = 10/25/2021	CHECKED -	REVISED -
	DATE -	REVISED -

**STATE OF ILLINOIS
DEPARTMENT OF TRANSPORTATION**

PLAN SHEETS WABASH			
SCALE:	SHEET 12	OF 15 SHEETS	STA. TO STA.

F.A.P. RTE.	SECTION	COUNTY	TOTAL SHEETS	SHEET NO.
664	(21RS-10, G-RS-16) PP	SANGAMON	32	23
CONTRACT NO. 72N10				
ILLINOIS FED. AID PROJECT				



MATCH LINE STA 573+00.00

MATCH LINE STA 588+00.00

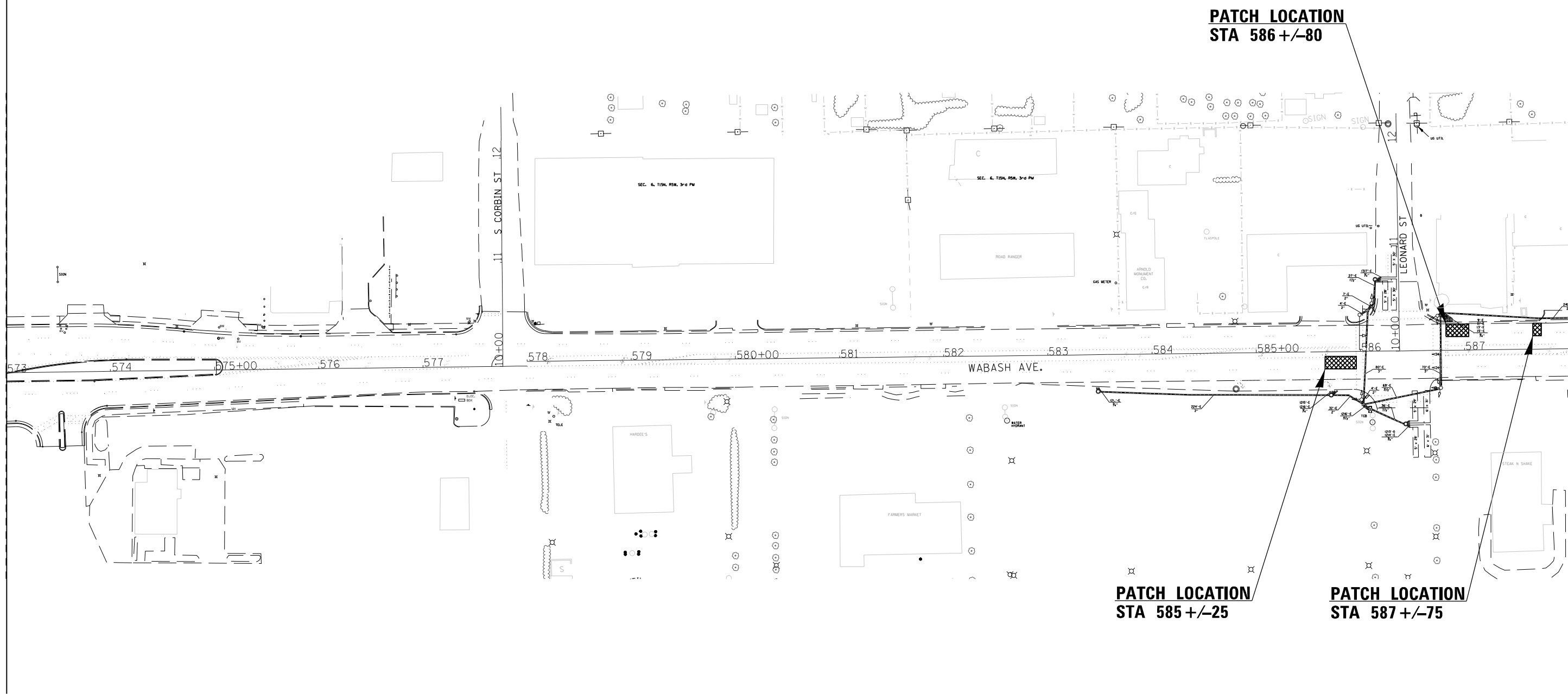

**PATCH LOCATION
STA 586+/-80**

**PATCH LOCATION
STA 585+/-25**

**PATCH LOCATION
STA 587+/-75**

-  **CLASS C PATCHING**
-  **PARTIAL DEPTH PATCHING - 2"**
-  **LONGITUDINAL JOINT AND CRACK PATCHING**

USER NAME = sotelof	DESIGNED -	REVISED -
	DRAWN -	REVISED -
PLOT SCALE = 100,0000' / in.	CHECKED -	REVISED -
PLOT DATE = 10/25/2021	DATE -	REVISED -

**STATE OF ILLINOIS
DEPARTMENT OF TRANSPORTATION**

**PLAN SHEETS
WABASH**

SCALE: SHEET 13 OF 15 SHEETS STA. TO STA.

F.A.P. RTE.	SECTION	COUNTY	TOTAL SHEETS	SHEET NO.
664	(21RS-10, G-RS-16) PP	SANGAMON	32	24
CONTRACT NO. 72N10				
ILLINOIS FED. AID PROJECT				

MODEL: Default
FILE NAME: p:\ultra-pw-bee-fwy.com\FWIDOT\Documents\DOT Office\Director_E\Project\0672N10\060003_5510\CAD\sheet\0672N10\sheet13.dwg



MATCH LINE STA 588+00.00

MATCH LINE STA 603+00.00

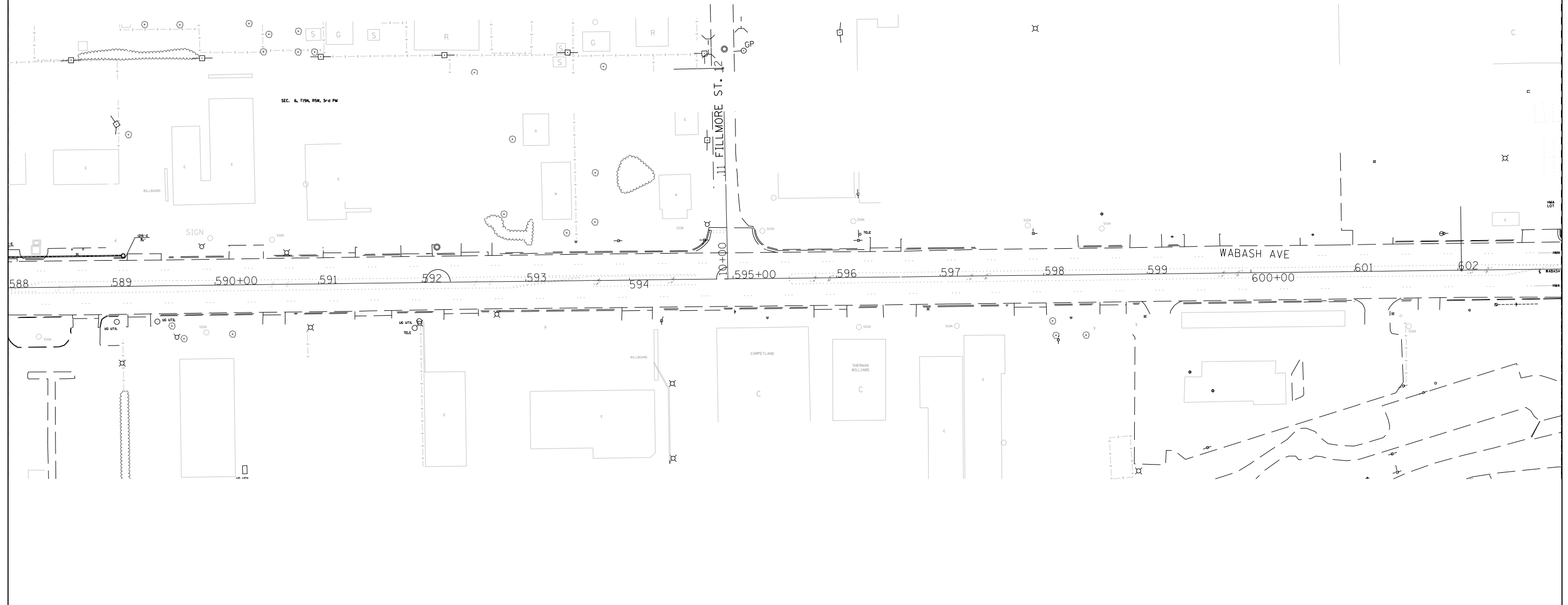

- CLASS C PATCHING**
- PARTIAL DEPTH PATCHING - 2"**
- LONGITUDINAL JOINT AND CRACK PATCHING**

MODEL: Default
FILE: \\mfe-pw-beadby.com\FW\DOT\Documents\DOT Office\District 6\Project\72N10\Drawings\72N10-Sub-C-Plan.sxd

USER NAME = sotelof	DESIGNED -	REVISED -
PLOT SCALE = 100,0000' / in.	DRAWN -	REVISED -
PLOT DATE = 10/25/2021	CHECKED -	REVISED -
	DATE -	REVISED -

**STATE OF ILLINOIS
DEPARTMENT OF TRANSPORTATION**

**PLAN SHEETS
WABASH**

SCALE: SHEET 14 OF 15 SHEETS STA. TO STA.

F.A.P. RTE.	SECTION	COUNTY	TOTAL SHEETS	SHEET NO.
664	(21RS-10, G-RS-16) PP	SANGAMON	32	25
CONTRACT NO. 72N10				
ILLINOIS FED. AID PROJECT				



MATCH LINE STA 603+00.00

STATION EQUATION:
 STA. 603+08.51 (BACK) =
 STA. 83+28.31 (AHEAD)

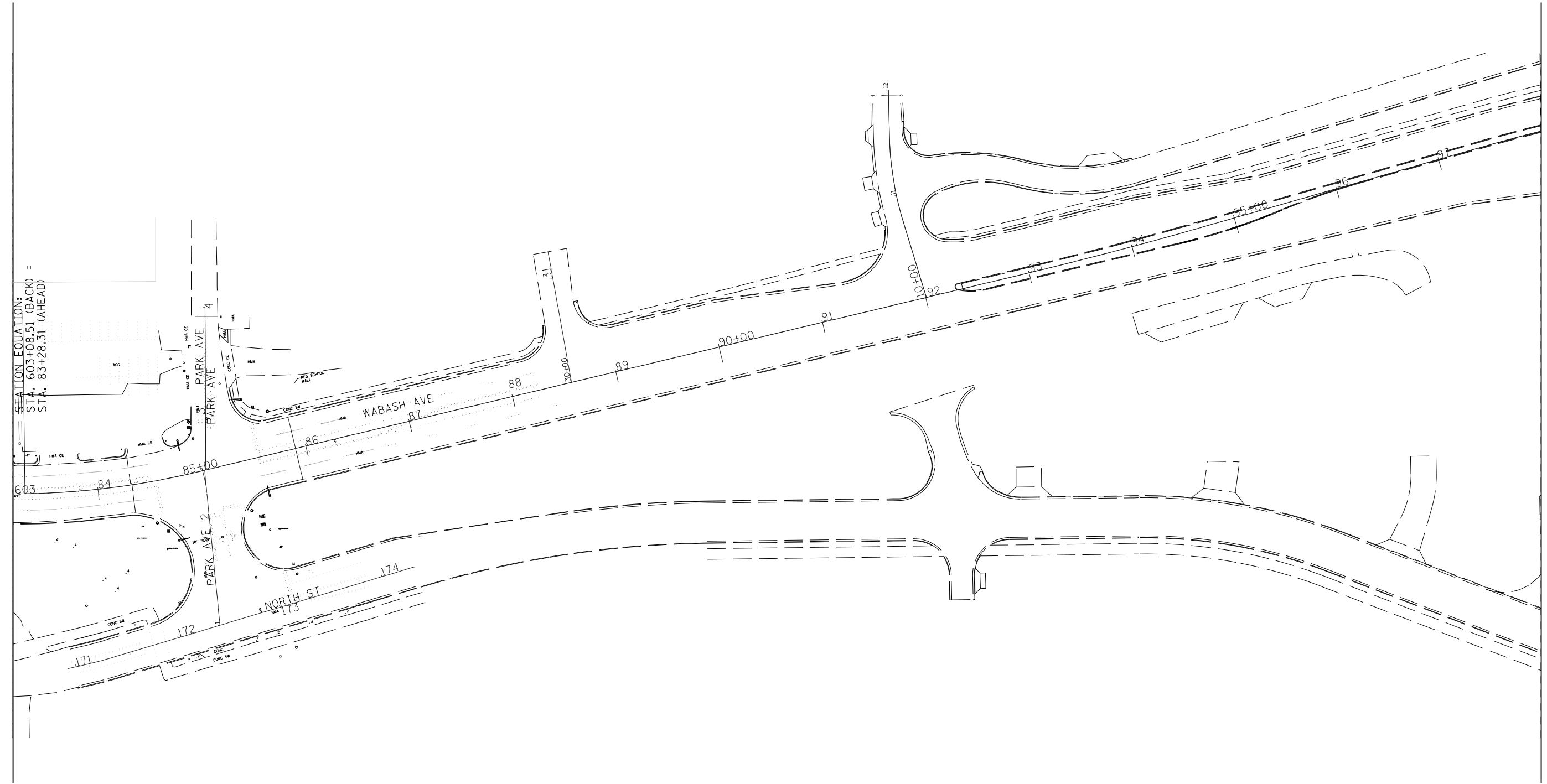

MATCH LINE STA 98+00.00

- CLASS C PATCHING**
- PARTIAL DEPTH PATCHING - 2"**
- LONGITUDINAL JOINT AND CRACK PATCHING**

MODEL: Default
 FILE NAME: p:\ultra-pw-bead-fy.com\FW\DOT\Documents\DOT Office\Director_E\Project\0672N10\CAD\Draw_S51\0672N10\Drawings\0672N10\Sheet15.dwg

USER NAME = sotelof	DESIGNED -	REVISED -
PLOT SCALE = 100,0000' / in.	DRAWN -	REVISED -
PLOT DATE = 10/25/2021	CHECKED -	REVISED -
	DATE -	REVISED -

**STATE OF ILLINOIS
 DEPARTMENT OF TRANSPORTATION**

PLAN SHEETS WABASH			
SCALE:	SHEET 15	OF 15 SHEETS	STA. TO STA.

F.A.P. RTE.	SECTION	COUNTY	TOTAL SHEETS	SHEET NO.
664	(21RS-10, G-RS-16) PP	SANGAMON	32	26
CONTRACT NO. 72N10				
ILLINOIS FED. AID PROJECT				

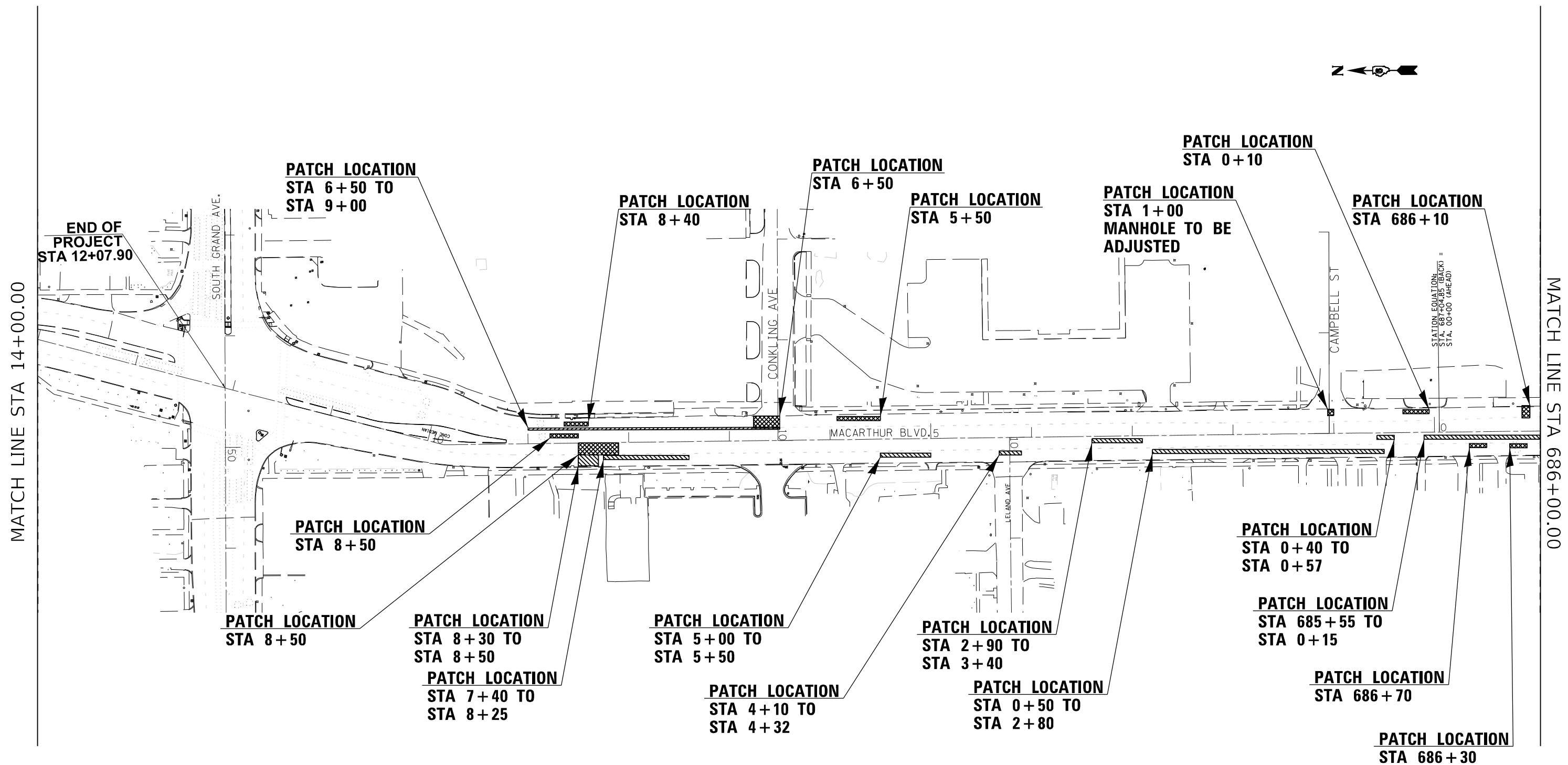
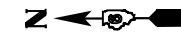

- CLASS C PATCHING
- PARTIAL DEPTH PATCHING - 2"
- LONGITUDINAL JOINT AND CRACK PATCHING

MODEL: Default
 FILE NAME: p:\projects\paw\beadby.com\p\w\dot\documents\DOT\office\Director_E\Project\0672N10\060000.dwg
 PROJECT: 0672N10\060000.dwg
 PLOT DATE: 10/25/2021

USER NAME = sotelof	DESIGNED -	REVISED -
	DRAWN -	REVISED -
PLOT SCALE = 100,0000' / in.	CHECKED -	REVISED -
PLOT DATE = 10/25/2021	DATE -	REVISED -

STATE OF ILLINOIS
DEPARTMENT OF TRANSPORTATION

PLAN SHEETS
MACARTHUR BLVD

SCALE: SHEET 1 OF 15 SHEETS STA. TO STA.

F.A.P. RTE.	SECTION	COUNTY	TOTAL SHEETS	SHEET NO.
664	(21RS-10, G-RS-16) PP	SANGAMON	32	27
ILLINOIS FED. AID PROJECT			CONTRACT NO. 72N10	

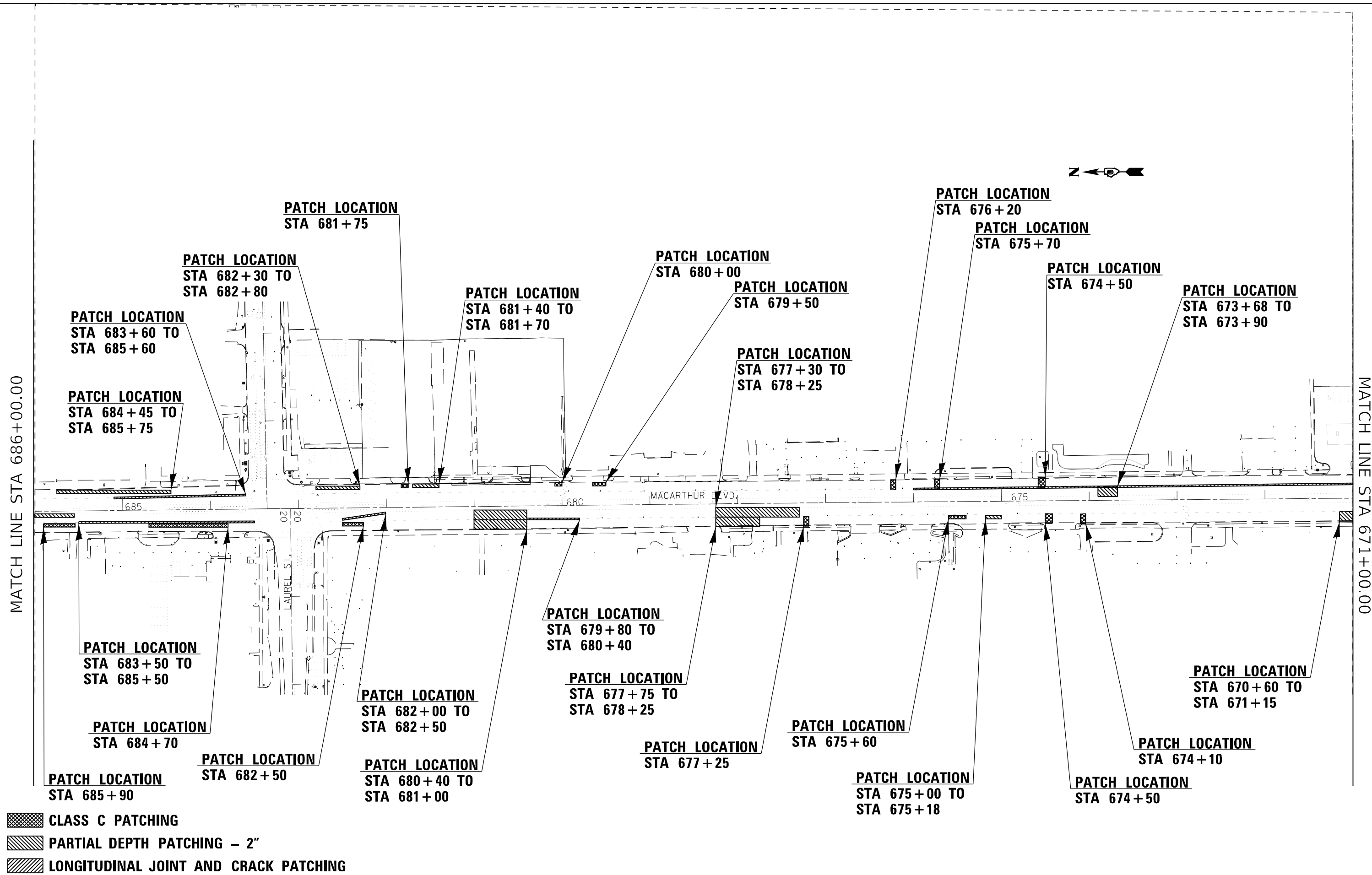
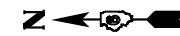

MATCH LINE STA 686+00.00

MATCH LINE STA 671+00.00

- CLASS C PATCHING
- PARTIAL DEPTH PATCHING - 2"
- LONGITUDINAL JOINT AND CRACK PATCHING

MODEL: Default
 FILE NAME: p:\projects\72N10\Drawings\DOT\Office\Drawings\72N10\Drawings\72N10\72N10-16-PP-28.dwg
 PROJECT: 72N10\Drawings\DOT\Office\Drawings\72N10\Drawings\72N10\72N10-16-PP-28.dwg

USER NAME = sotelof	DESIGNED -	REVISED -
	DRAWN -	REVISED -
PLOT SCALE = 100,0000' / in.	CHECKED -	REVISED -
PLOT DATE = 10/25/2021	DATE -	REVISED -

STATE OF ILLINOIS
DEPARTMENT OF TRANSPORTATION

PLAN SHEETS			
MACARTHUR BLVD			
SCALE:	SHEET 2	OF 15 SHEETS	STA. TO STA.

F.A.P. RTE.	SECTION	COUNTY	TOTAL SHEETS	SHEET NO.
664	(21RS-10, G-RS-16) PP	SANGAMON	32	28
CONTRACT NO. 72N10				
ILLINOIS FED. AID PROJECT				

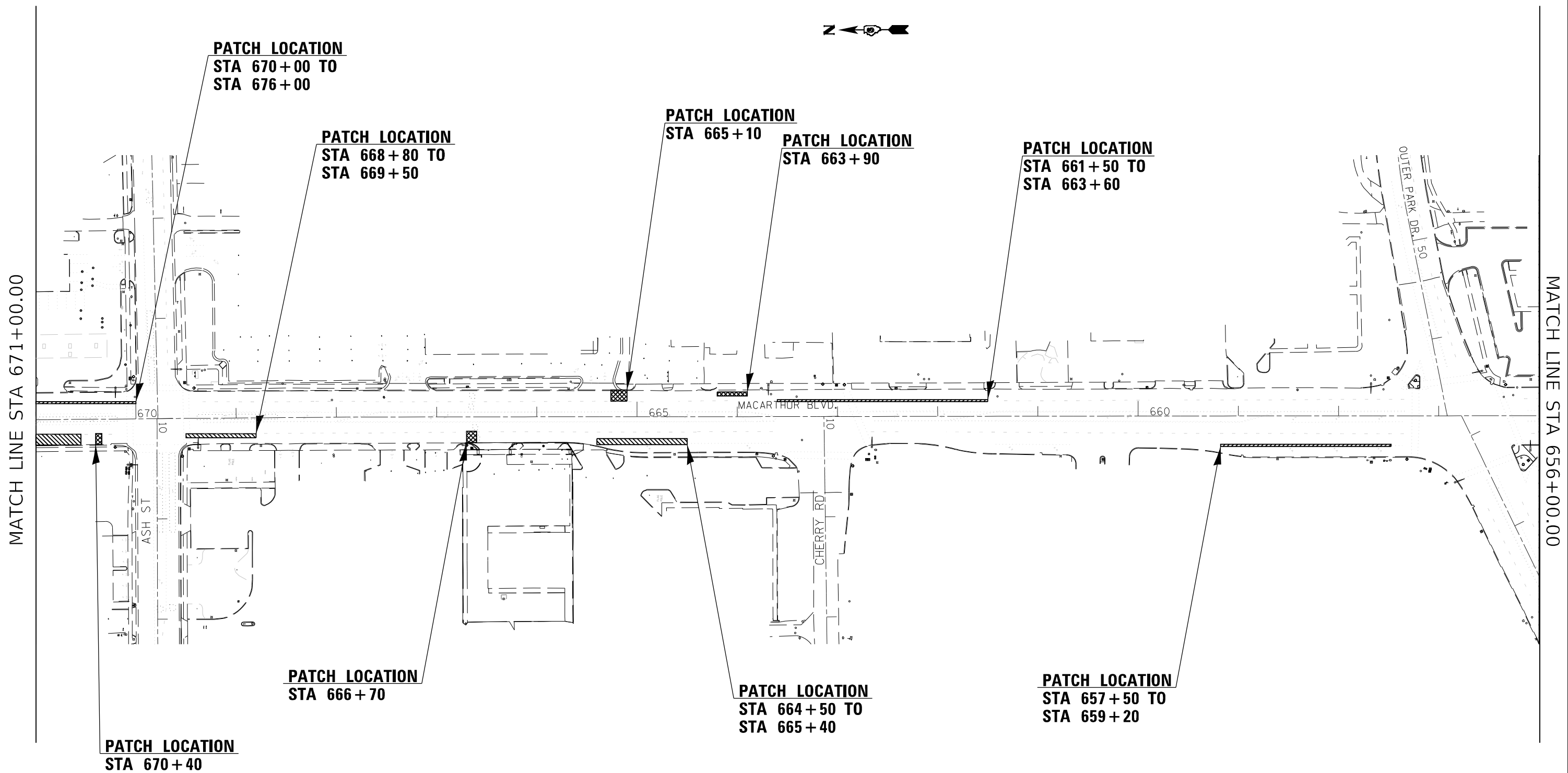

PATCH LOCATION
STA 670+00 TO
STA 676+00

PATCH LOCATION
STA 668+80 TO
STA 669+50

PATCH LOCATION
STA 665+10

PATCH LOCATION
STA 663+90

PATCH LOCATION
STA 661+50 TO
STA 663+60

PATCH LOCATION
STA 666+70

PATCH LOCATION
STA 664+50 TO
STA 665+40

PATCH LOCATION
STA 657+50 TO
STA 659+20

PATCH LOCATION
STA 670+40

- CLASS C PATCHING**
- PARTIAL DEPTH PATCHING - 2"**
- LONGITUDINAL JOINT AND CRACK PATCHING**

MODEL: Default
 FILE NAME: p:\project-pw\beadby.com\p\7\DOT\Documents\DOT Office\Director: E:\Project\0672\N10\CADD\03_5510\CADD\beadby0672\N10\beadby.dwg

USER NAME = sotelof	DESIGNED -	REVISED -
	DRAWN -	REVISED -
PLOT SCALE = 100,0000' / in.	CHECKED -	REVISED -
PLOT DATE = 10/25/2021	DATE -	REVISED -

STATE OF ILLINOIS
DEPARTMENT OF TRANSPORTATION

PLAN SHEETS
MACARTHUR BLVD

SCALE: SHEET 3 OF 15 SHEETS STA. TO STA.

F.A.P. RTE.	SECTION	COUNTY	TOTAL SHEETS	SHEET NO.
664	(21RS-10, G-RS-16) PP	SANGAMON	32	29
				CONTRACT NO. 72N10
ILLINOIS FED. AID PROJECT				

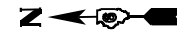

MATCH LINE STA 656+00.00

MATCH LINE STA 641+00.00

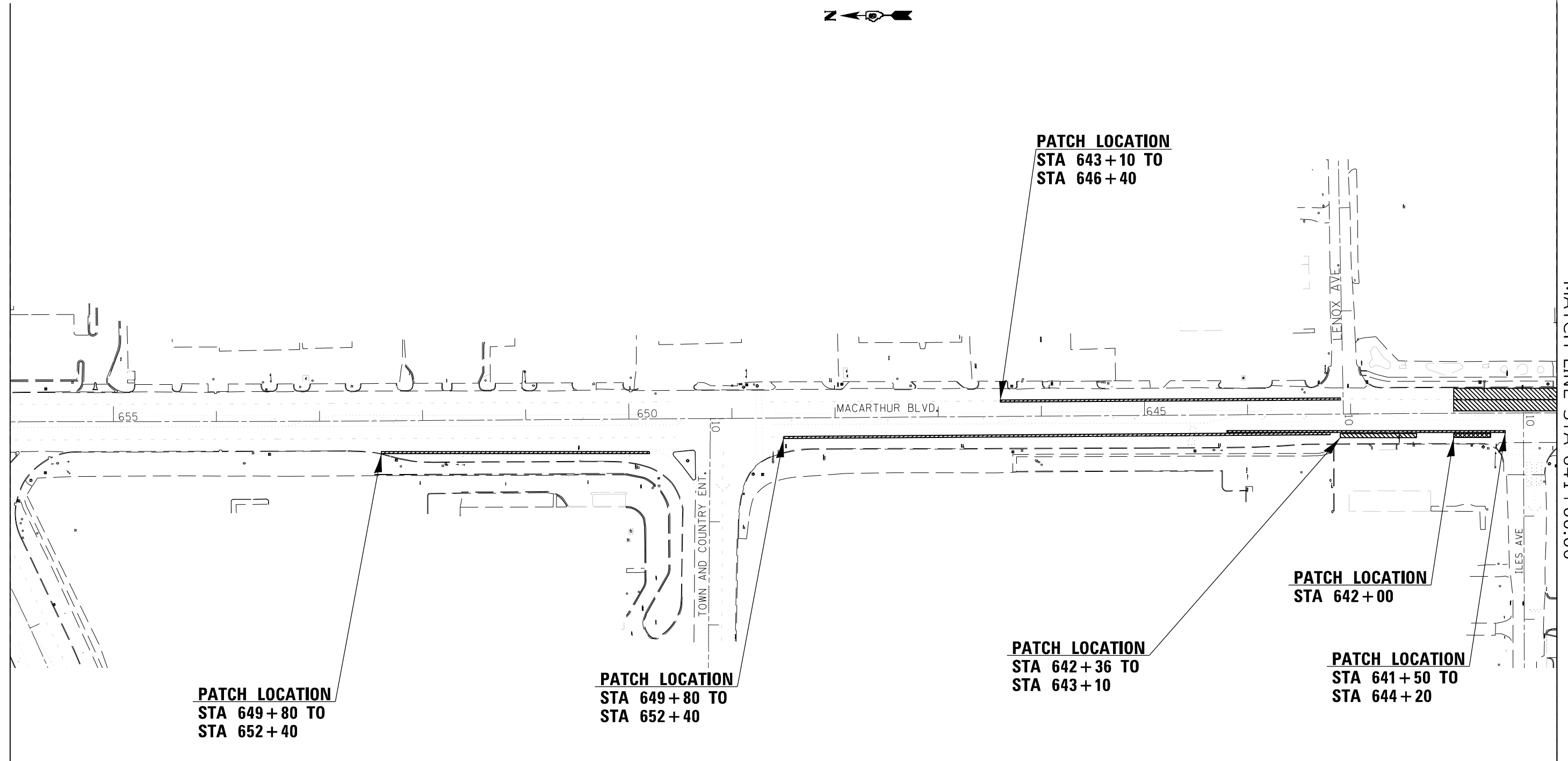

PATCH LOCATION
STA 643+10 TO
STA 646+40

PATCH LOCATION
STA 649+80 TO
STA 652+40

PATCH LOCATION
STA 649+80 TO
STA 652+40

PATCH LOCATION
STA 642+36 TO
STA 643+10

PATCH LOCATION
STA 642+00

PATCH LOCATION
STA 641+50 TO
STA 644+20

- CLASS C PATCHING**
- PARTIAL DEPTH PATCHING - 2"**
- LONGITUDINAL JOINT AND CRACK PATCHING**

MODEL: Default
 FILE NAME: p:\project-pw-bee-fy.com\p\72N10\Documents\DOT Office\Drawings\72N10\72N10-16-PP.dwg
 PROJECT: 72N10\000Data\SS10\000\Sheet\72N10-16-PP.dwg

USER NAME = sotelof	DESIGNED -	REVISED -
PLOT SCALE = 100,0000' / in.	DRAWN -	REVISED -
PLOT DATE = 10/25/2021	CHECKED -	REVISED -
	DATE -	REVISED -

STATE OF ILLINOIS
DEPARTMENT OF TRANSPORTATION

PLAN SHEETS			
MACARTHUR BLVD			
SCALE:	SHEET 4	OF 15 SHEETS	STA. TO STA.

F.A.P. RTE.	SECTION	COUNTY	TOTAL SHEETS	SHEET NO.
664	(21RS-10, G-RS-16) PP	SANGAMON	32	30
CONTRACT NO. 72N10				
ILLINOIS FED. AID PROJECT				

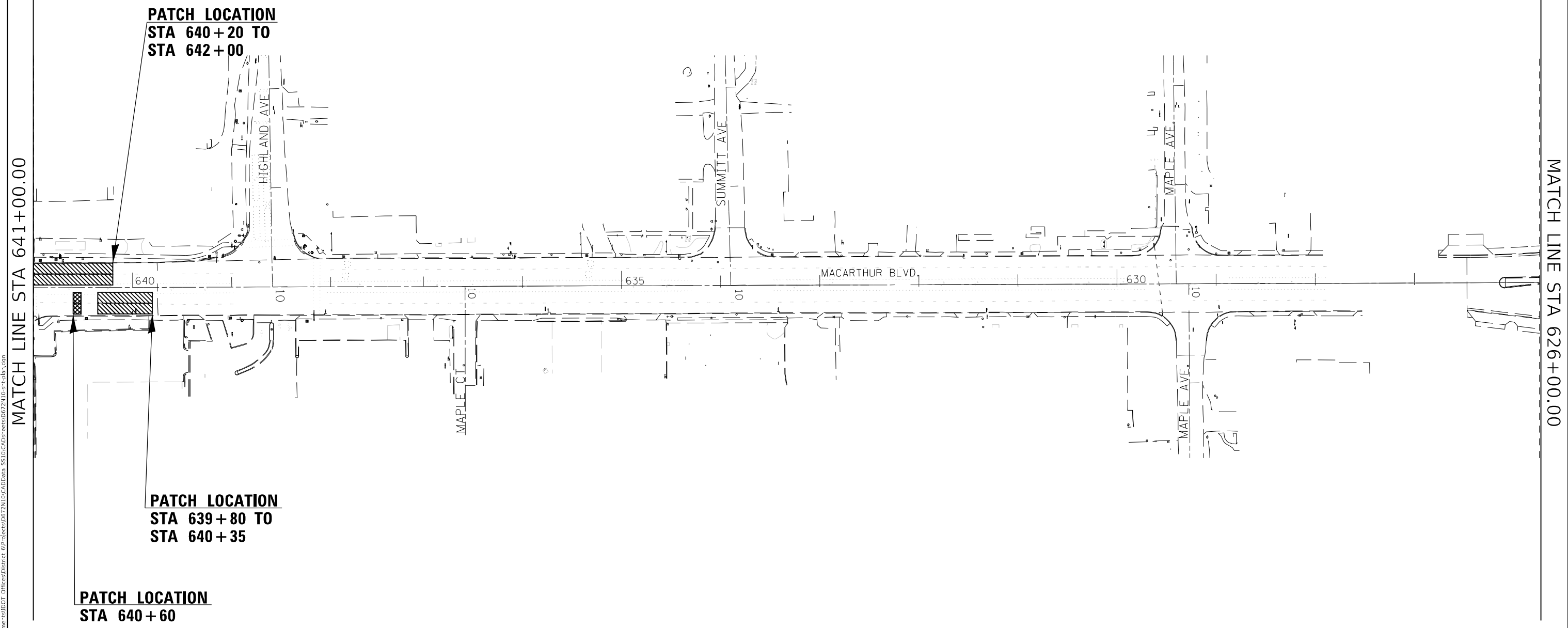

MATCH LINE STA 641+00.00

MATCH LINE STA 626+00.00

PATCH LOCATION
STA 640+20 TO
STA 642+00

PATCH LOCATION
STA 639+80 TO
STA 640+35

PATCH LOCATION
STA 640+60

- CLASS C PATCHING**
- PARTIAL DEPTH PATCHING - 2"**
- LONGITUDINAL JOINT AND CRACK PATCHING**

MODEL: Default
 FILE NAME: p:\project-pw-bee-fy.com\p\id\DOT\Documents\DOT Office\District 6\Project\0672N10\CADD\03_5510\CADD\sheet\0672N10\sheet\plan.dwg
 PROJECT: 0672N10\CADD\03_5510\CADD\sheet\0672N10\sheet\plan.dwg

USER NAME = sotelof	DESIGNED -	REVISED -
PLOT SCALE = 100,0000' / in.	DRAWN -	REVISED -
PLOT DATE = 10/25/2021	CHECKED -	REVISED -
	DATE -	REVISED -

STATE OF ILLINOIS
DEPARTMENT OF TRANSPORTATION

PLAN SHEETS			
MACARTHUR BLVD			
SCALE:	SHEET 5	OF 15 SHEETS	STA. TO STA.

F.A.P. RTE.	SECTION	COUNTY	TOTAL SHEETS	SHEET NO.
664	(21RS-10, G-RS-16) PP	SANGAMON	32	31
			CONTRACT NO. 72N10	
ILLINOIS FED. AID PROJECT				



MODEL: Default
 FILE NAME: p:\project-pw-bee-fy.com\p\id\DOT\Documents\DOT Office\Dir\dir_6\Project\0672N10\CADD\0672N10\Sheet\plan.com

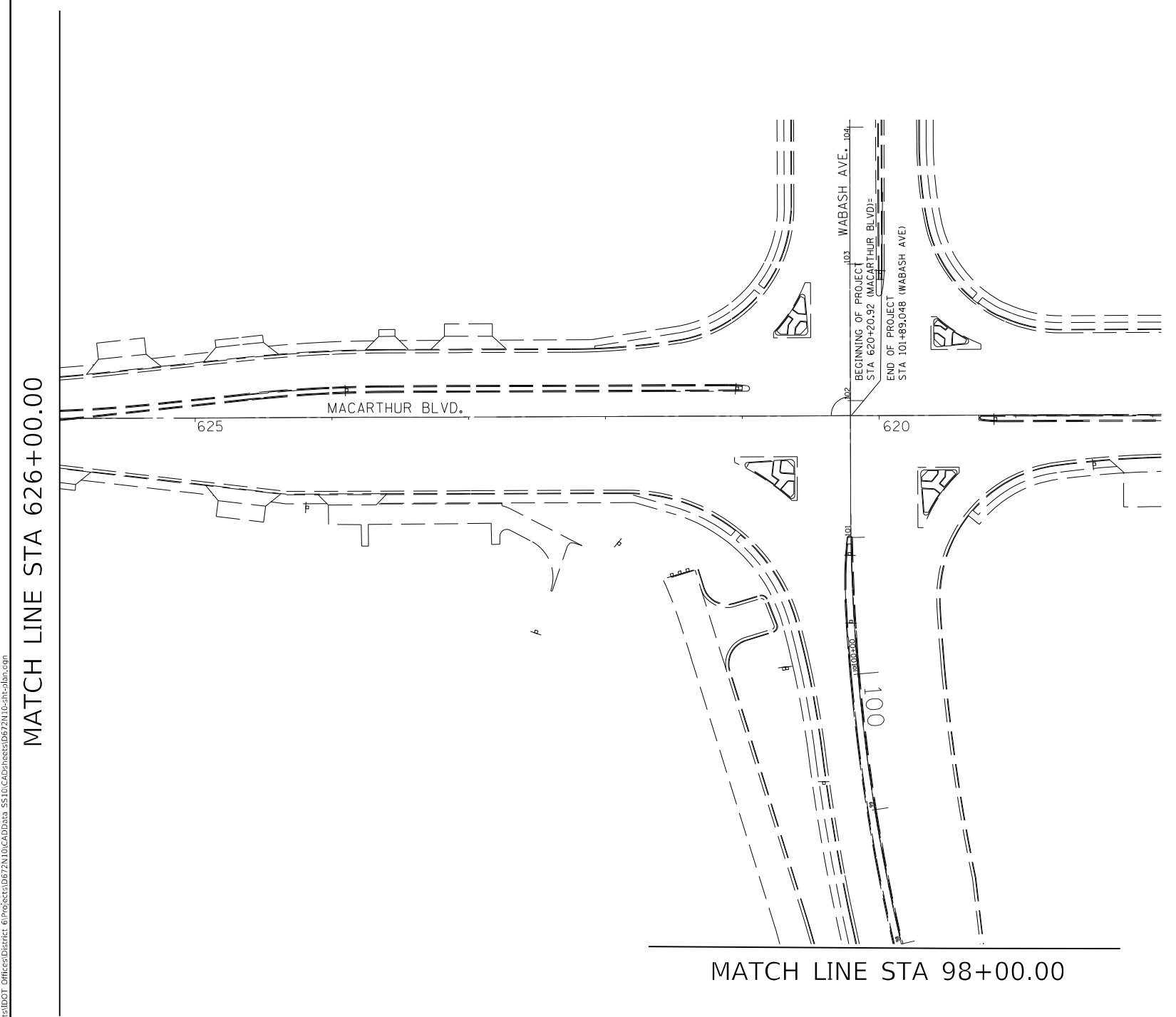

MATCH LINE STA 626+00.00

MATCH LINE STA 98+00.00

- CLASS C PATCHING**
- PARTIAL DEPTH PATCHING - 2"**
- LONGITUDINAL JOINT AND CRACK PATCHING**

USER NAME = sotelof	DESIGNED -	REVISED -
	DRAWN -	REVISED -
PLOT SCALE = 100,0000' / in.	CHECKED -	REVISED -
PLOT DATE = 10/25/2021	DATE -	REVISED -

**STATE OF ILLINOIS
DEPARTMENT OF TRANSPORTATION**

PLAN SHEETS MACARTHUR BLVD			
SCALE:	SHEET 6	OF 15 SHEETS	STA. TO STA.

F.A.P. RTE.	SECTION	COUNTY	TOTAL SHEETS	SHEET NO.
664	(21RS-10, G-RS-16) PP	SANGAMON	32	32
CONTRACT NO. 72N10				
ILLINOIS FED. AID PROJECT				