

CONSTRUCTION PLANS

AIRCRAFT PARKING APRON REHABILITATION

JOLIET REGIONAL PORT DISTRICT
LEWIS UNIVERSITY AIRPORT (LOT)
ROMEORVILLE, WILL COUNTY, ILLINOIS

SBG PROJECT NO. 3-17-SBGP-117
IDA PROJECT NO. LOT-4298

PREVIOUSLY BID AS ITEM 06A IN
THE JUNE 13, 2014 IDOT LETTING

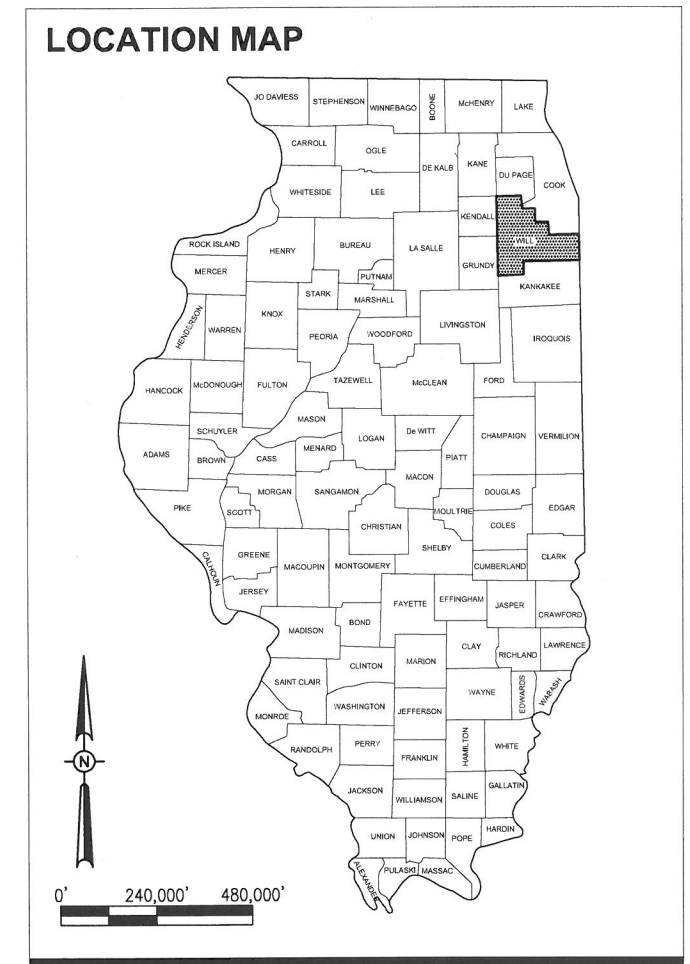
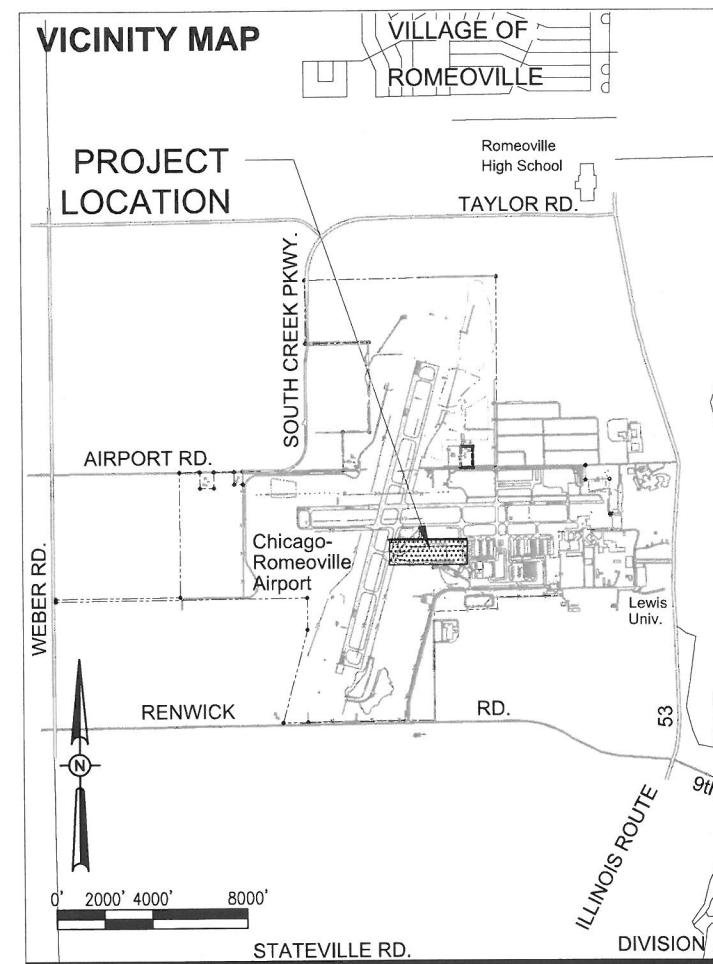

NOTICE TO CONTRACTORS AND BIDDERS

THESE CONSTRUCTION PLANS RELY UPON THE SPECIAL PROVISIONS AND THE SPECIFICATIONS TO PROVIDE FOR A COMPLETE DESCRIPTION OF THE WORK AND CONSTRUCTION REQUIREMENTS. THE PLANS SHALL ONLY BE USED IN COMBINATION WITH ALL CONTRACT DOCUMENTS.

No.	Issue/Description	Sheets Changed	Date	By

Seal

 Date of Plans
 Exp. 11/30/15
 NOVEMBER 14, 2014
 Kevin M. Spitz, P.E.,
 Project Engineer

HANSON PROFESSIONAL SERVICES INC.
 815 Commerce Drive, Suite 200 Oak
 Brook, Illinois 60523
 Telephone: 630.990.3800
 Fax: 630.990.3801

 Ronald M. Hudson, AICP
 Project Manager
 NOVEMBER 14, 2014
 Date

Chicago-Romeoville Airport
 JOLIET REGIONAL PORT DISTRICT

 Chris Lawson
 Director of Aviation
 1 George Michas Drive
 Romeoville, Illinois 60446
 Telephone: 815.838.9497
 Fax: 815.838.9524
 NOVEMBER 14, 2014
 Date

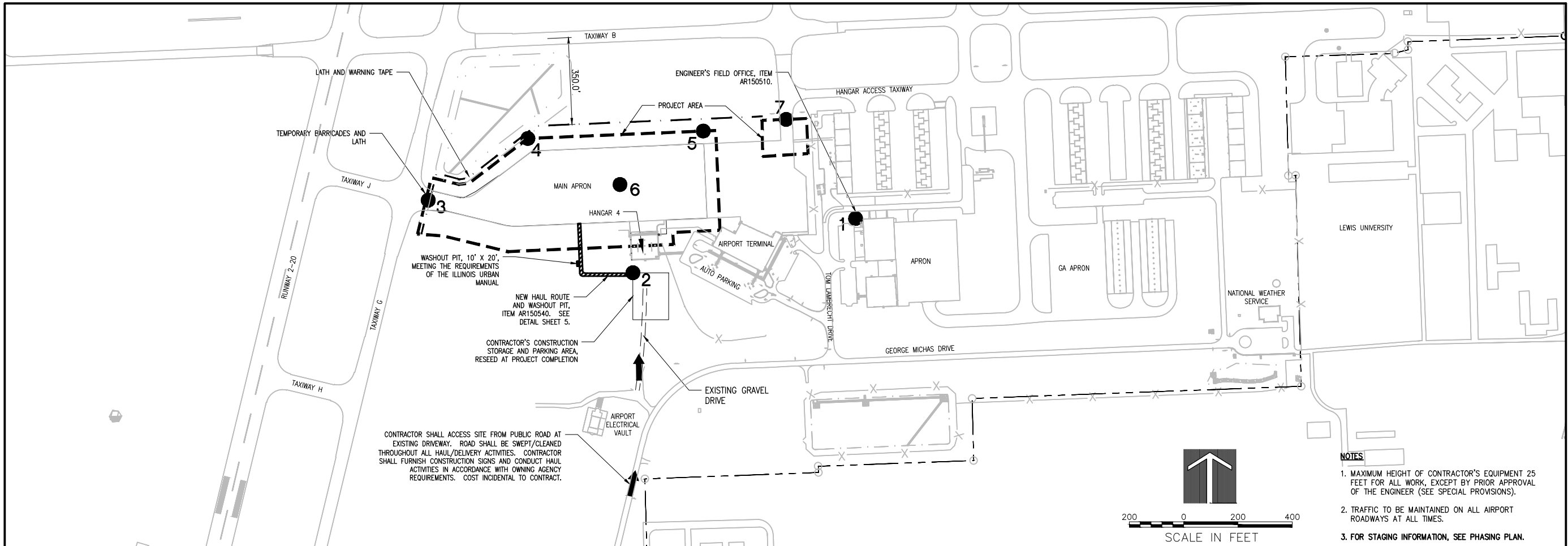

- NOTES**
1. MAXIMUM HEIGHT OF CONTRACTOR'S EQUIPMENT 25 FEET FOR ALL WORK, EXCEPT BY PRIOR APPROVAL OF THE ENGINEER (SEE SPECIAL PROVISIONS).
 2. TRAFFIC TO BE MAINTAINED ON ALL AIRPORT ROADWAYS AT ALL TIMES.
 3. FOR STAGING INFORMATION, SEE PHASING PLAN.

GENERAL NOTES

PROJECT DESCRIPTION

THIS PROJECT IS TO REHABILITATE THE MAIN AIRCRAFT PARKING APRON AT LEWIS UNIVERSITY AIRPORT INCLUDING, AMONG OTHER INCIDENTAL WORK, THE FOLLOWING ITEMS:

- PLACEMENT OF TEMPORARY SOIL EROSION CONTROL MEASURES.
- PROVISION OF TRAFFIC MAINTENANCE AND HAUL ROUTE.
- ADJUSTMENT OF EXISTING SUBSURFACE UNDERDRAIN AND DRAINAGE STRUCTURES.
- REPLACEMENT OF EXISTING MANHOLE FRAMES AND GRATES.
- MILLING OR REMOVAL OF PORTIONS OF EXISTING HOT MIX ASPHALT (HMA) PAVEMENTS.
- PCC OVERLAY OF EXISTING ASPHALT PAVEMENTS.
- CONSTRUCTION OF APRON PAVEMENTS NEAR HANGAR 4.
- INSTALLATION OF TIEDOWNS AND GROUND RODS.
- INSTALLATION OF INFILTRATION TRENCH IN EXISTING APRON SWALE.
- PLACEMENT OF PAVEMENT MARKINGS.
- TOPSOILING, SEEDING AND MULCHING, AND SODDING ALONG NEW PAVEMENT EDGES.

RUNWAY END COORDINATES

DESCRIPTION	LATITUDE	LONGITUDE	RUNWAY STATION
RUNWAY 9 END	41°36'28.9758" N	88°06'15.9913" W	23+85.38
RUNWAY 27 END	41°36'31.1949" N	88°05'01.0708" W	80+81.15
RUNWAY 2 END	41°35'57.2760" N	88°06'03.2207" W	100+00.40
RUNWAY 20 END	41°36'59.6552" N	88°05'42.9106" W	165+00.00

PROTECTION OF EXISTING AIRPORT FACILITIES

THE CONTRACTOR IS TO BE RESPONSIBLE FOR THE PROTECTION OF EXISTING UNDERGROUND AND OVERHEAD UTILITIES AND LIGHTING EQUIPMENT; DRIVEWAY AND ROAD PAVEMENT AND SHOULDERS; RUNWAY, TAXIWAY AND APRON PAVEMENTS AND SHOULDERS; RUNWAY, TAXIWAY AND AIRPORT LIGHTING EQUIPMENT; AND SEEDED AND TURFED AREAS THAT ARE UTILIZED IN OR AFFECTED BY THE CONTRACTOR'S ACTIVITIES. ITEMS DAMAGED BY THE CONTRACTOR ARE TO BE REPAIRED AT CONTRACTOR'S EXPENSE AND TO THE SATISFACTION OF AIRPORT MANAGER AND THE OWNER'S REPRESENTATIVE.

IN ADDITION, WHEN CONDITIONS DICTATE OR AS DETERMINED BY THE AIRPORT MANAGER OR THE OWNER'S REPRESENTATIVE, THE CONTRACTOR SHALL BE REQUIRED TO USE A PICK-UP TYPE SWEEPER IN ALL ACTIVE CONSTRUCTION AIRFIELD PAVEMENT AREAS. THE CONTRACTOR WILL BE REQUIRED TO HAVE A SWEEPER AVAILABLE FOR USE AT ALL TIMES. THE COST OF SWEEPING SHALL BE CONSIDERED INCIDENTAL TO THE CONTRACT.

CONTRACTOR'S ACCESS AND TEMPORARY FACILITIES

CONTRACTOR'S ACCESS TO THE PROJECT WHEN ON AIRPORT PROPERTY IS SHOWN ON THIS SHEET. CONTRACTOR'S ACCESS TO THE AIRPORT ITSELF IS TO BE PROVIDED BY PUBLIC RIGHTS-OF-WAY. THE CONTRACTOR IS TO SECURE ALL NECESSARY PERMITS FOR THE USE OF ANY PUBLIC RIGHTS-OF-WAY AND IS TO MAINTAIN TRAFFIC ON THESE PUBLIC ROADS AT ALL TIMES, WITH THE COSTS OF PERMITTING, CLEANING AND REPAIRING OF PAVEMENT DAMAGED BY CONTRACTOR'S ACTIVITIES INCIDENTAL TO THE CONTRACT. USE OF AND REPAIRS TO ANY PUBLIC FACILITIES ARE TO BE COMPLETED TO THE SATISFACTION OF THE FACILITY'S OWNER.

THE CONTRACTOR IS TO PROVIDE TEMPORARY CONSTRUCTION ROADS WITHIN THE CONSTRUCTION LIMIT LINES AS MAY BE REQUIRED BY HIS ACTIVITIES. HEAVY VEHICLES SHALL NOT CROSS EXISTING PAVEMENT SURFACES EXCEPT AS APPROVED BY THE AIRPORT MANAGER AND THE OWNER'S REPRESENTATIVE. ANY DAMAGE TO PAVEMENTS THAT MAY OCCUR BY THE CONTRACTOR'S ACTIVITIES SHALL BE REPAIRED AT THE CONTRACTOR'S EXPENSE AND TO THE SATISFACTION OF THE AIRPORT MANAGER AND THE OWNER'S REPRESENTATIVE.

THE CONTRACTOR IS TO PROVIDE AN EQUIPMENT STORAGE AND PARKING AREA AT THE LOCATIONS SHOWN ON THIS SHEET. IT IS THE CONTRACTOR'S RESPONSIBILITY TO MAINTAIN THE ACCESS ROADS AND THE STORAGE AREA DURING CONSTRUCTION AND TO RESTORE THE AREAS AT PROJECT COMPLETION TO CONDITIONS SUITABLE TO THE AIRPORT MANAGER AND THE OWNER'S REPRESENTATIVE. AT THE AIRPORT MANAGER'S DISCRETION, THE TEMPORARY FACILITIES MAY REMAIN, BUT THEY MUST BE LEFT IN CONDITIONS SUITABLE TO THE AIRPORT MANAGER. THE COST OF PROVIDING, MAINTAINING AND RESTORING THE TEMPORARY FACILITIES IS INCIDENTAL TO THE CONTRACT.

RESPONSIBILITY FOR EXISTING UTILITIES

THE LOCATION, SIZE AND/OR TYPE OF MATERIAL OF EXISTING UNDERGROUND OR OVERHEAD UTILITIES AS MAY BE INDICATED ON THESE CONSTRUCTION PLANS IS NOT REPRESENTED AS BEING ACCURATE, SUFFICIENT OR COMPLETE. NEITHER THE OWNER NOR THE PROJECT ENGINEER HAVE INDEPENDENTLY VERIFIED THIS INFORMATION AND NEITHER ASSUMES ANY RESPONSIBILITY WHATSOEVER IN RESPECT TO THE ACCURACY, SUFFICIENCY OR COMPLETENESS OF THE INFORMATION AND GIVE NO EXPRESSED OR IMPLIED GUARANTEE THAT ANY CONDITIONS INDICATED ARE REPRESENTATIVE OF ACTUAL CONDITIONS TO BE ENCOUNTERED.

IT SHALL BE THE CONTRACTOR'S RESPONSIBILITY TO DETERMINE THE ACTUAL LOCATION OF ALL SUCH FACILITIES, INCLUDING SERVICE CONNECTIONS TO UNDERGROUND UTILITIES. PRIOR TO CONSTRUCTION, THE CONTRACTOR SHALL NOTIFY ALL UTILITY COMPANIES AND AGENCIES OF HIS CONSTRUCTION PLANS AND SHALL OBTAIN FROM EACH PARTY DETAILED INFORMATION AND ASSISTANCE RELATIVE TO THE LOCATION OF ALL UTILITIES AND THE WORKING SCHEDULE OF ANY REMOVALS OR ADJUSTMENTS REQUIRED OF THE UTILITY. THE CONTRACTOR SHALL CONTACT J.U.L.I.E. (PHONE 800-892-0123) TO ASSIST IN THE ABOVE.

THE CONTRACTOR SHALL PROTECT ANY FACILITIES TO THE SATISFACTION OF THE UTILITY OR OWNING-AGENCY WITH THE COST OF ANY REQUIRED PROTECTION TO BE INCIDENTAL TO THE CONTRACT. IN THE EVENT A UTILITY LINE OR SERVICE IS UNEXPECTEDLY ENCOUNTERED DURING CONSTRUCTION, THE CONTRACTOR SHALL IMMEDIATELY NOTIFY THE OWNER'S REPRESENTATIVE AND THE UTILITY COMPANY OR AGENCY OF JURISDICTION. ANY SUCH UTILITIES DISTURBED BY THE CONTRACTOR'S OPERATIONS SHALL BE RESTORED TO SERVICE AT ONCE.

EXISTING BENCHMARKS

PROJECT BENCHMARKS ARE AS FOLLOWS:

- B.M.1 N 1,800,236.82
E 1,051,080.54
ELEV. 666.67
- B.M.2 N 1,800,302.96
E 1,052,719.90
ELEV. 664.18

THIS DATA IS NOT ILLINOIS STATE PLANE COORDINATES



PROJECT IS LOCATED IN
NORTH 1/2 OF SECTION 16,
LOCKPORT TOWNSHIP, WILL COUNTY

OBJECT INFORMATION

ITEM NO.	DESCRIPTION	STAGE	MOBILITY	GROUND ELEVATION	OBJECT ELEVATION	LATITUDE	LONGITUDE	RUNWAY 2-20 STATION	RUNWAY 2-20 OFFSET	RUNWAY 2-20 EXIST EL.	RUNWAY 9-27 STATION	RUNWAY 9-27 OFFSET	RUNWAY 9-27 EXIST EL.
1	ENGINEER'S FIELD OFFICE	ALL	STATIONARY	665.4	680.4	41° 36' 18.8014" N	88° 05' 26.6159" W	127+77.05	2184.2	668.5	60+92.60	1176.8	668.7
2	CONSTRUCTION EQUIPMENT	ALL	MOVING	667.3	692.3	41° 36' 16.6644" N	88° 05' 38.4349" W	123+53.73	1363.4	670.1	51+86.88	1357.5	667.5
3	CONSTRUCTION EQUIPMENT	1	MOVING	667.9	692.9	41° 36' 19.5779" N	88° 05' 49.2802" W	124+44.60	493.0	669.7	43+75.27	1030.2	667.7
4	CONSTRUCTION EQUIPMENT	1	MOVING	666.2	691.2	41° 36' 22.0217" N	88° 05' 43.9866" W	127+80.34	824.9	668.5	47+86.89	799.0	667.3
5	CONSTRUCTION EQUIPMENT	1	MOVING	666.2	691.2	41° 36' 22.2980" N	88° 05' 34.6808" W	129+75.36	1505.0	668.3	54+94.39	799.0	667.9
6	CONSTRUCTION EQUIPMENT	2	MOVING	667.4	692.4	41° 36' 20.1785" N	88° 05' 39.1072" W	126+87.13	1229.3	668.8	51+49.90	1000.1	667.5
7	CONSTRUCTION EQUIPMENT	2	MOVING	667.7	692.7	41° 36' 22.7537" N	88° 05' 30.2835" W	130+99.48	1818.6	668.3	58+30.00	766.1	668.6

NOTES

1. COORDINATES ARE IN NAD 83 FOR HORIZONTAL AND NAVD 88 FOR VERTICAL.
2. STATIONS, OFFSETS AND ELEVATIONS SHOWN ARE IN FEET.
3. THE APPROACH END OF RUNWAY 9 IS STATION 23+85. THE APPROACH END OF RUNWAY 2 IS STATION 100+00.
4. THE AIRPORT REFERENCE CODE FOR RUNWAY 9-27 IS B-II WITH NONPRECISION APPROACHES WITH VISIBILITY 1 MILE OR GREATER ON BOTH RUNWAY 9 AND RUNWAY 27.
5. THE AIRPORT REFERENCE CODE FOR RUNWAY 2-20 IS D-III WITH NONPRECISION APPROACHES WITH VISIBILITY AS LOW AS 3/4 MILE ON RUNWAY 2 AND AS LOW AS 1 MILE ON RUNWAY 20.

AIRCRAFT PARKING APRON REHABILITATION

IDA No: LOT-4298
SBG No: 3-17-SBGP-117
LE047

NO.	DATE	DESCRIPTION		
		LAY	DWN	REV

ISSUE: November 14, 2014
PROJECT NO: 13A0089
CAD FILE: 03-SITE & SAFETY PLAN.DWG
LAYOUT BY: KMS 2/14/14
DRAWN BY: KMS 2/14/14
REVIEWED BY: RMH 11/14/14
© Copyright Hanson Professional Services Inc. 2011
SHEET TITLE

SITE PLAN, SAFETY PLAN, AND GENERAL NOTES

STAGE 1

NOTES

1. ALL CONTRACTOR ACTIVITIES SHALL TAKE PLACE WITHIN CONSTRUCTION LIMIT LINES AS SHOWN.
2. ALL CONSTRUCTION EQUIPMENT WILL BE LIMITED TO A HEIGHT OF 25 FEET UNLESS PRIOR APPROVAL GIVEN BY THE ENGINEER (SEE SPECIAL PROVISIONS)
3. CONTRACTOR'S EQUIPMENT MAY NOT DISRUPT FLIGHT OPERATIONS ON RUNWAY 2-20 OR 9-27 AT ANY TIME.
4. TRAFFIC TO BE MAINTAINED ON ALL AIRPORT ROADWAYS AT ALL TIMES.
5. SEE CONSTRUCTION SITE PLAN ON SHEET 3 AND SAFETY NOTES ON SHEET 5.

THE FOLLOWING ITEMS ARE TO BE COMPLETED IN STAGE 1:

1. CRACK SEALING WITHIN STAGE 1 LIMITS.
2. REMOVE FENCE WITHIN STAGE 1 LIMITS.
3. ADJUST UNDERDRAIN, TAXIWAY EDGE LIGHTS, AND MANHOLES WITHIN STAGE 1 LIMITS.
4. INSTALL TRENCH DRAIN WITHIN STAGE 1 LIMITS.
5. PLACE AGGREGATE BASE AND PCC PAVEMENT AS SHOW IN THE PLANS WITHIN STAGE 1 LIMITS.
6. GRADE AND LANDSCAPE WITHIN STAGE 1 LIMITS.

STAGE 2

NOTES

1. ALL CONTRACTOR ACTIVITIES SHALL TAKE PLACE WITHIN CONSTRUCTION LIMIT LINES AS SHOWN.
2. ALL CONSTRUCTION EQUIPMENT WILL BE LIMITED TO A HEIGHT OF 25 FEET UNLESS PRIOR APPROVAL GIVEN BY THE ENGINEER (SEE SPECIAL PROVISIONS)
3. CONTRACTOR'S EQUIPMENT MAY NOT DISRUPT FLIGHT OPERATIONS ON RUNWAY 2-20 OR 9-27 AT ANY TIME.
4. TRAFFIC TO BE MAINTAINED ON ALL AIRPORT ROADWAYS AT ALL TIMES.
5. SEE CONSTRUCTION SITE PLAN ON SHEET 3 AND SAFETY NOTES ON SHEET 5.

THE FOLLOWING ITEMS ARE TO BE COMPLETED IN STAGE 2:

1. CRACK SEALING WITHIN STAGE 2 LIMITS.
2. REMOVE FENCE WITHIN STAGE 2 LIMITS.
3. ADJUST MANHOLES WITHIN STAGE 2 LIMITS.
4. INSTALL TRENCH DRAIN AND CONNECT TO EXISTING MANHOLE WITHIN STAGE 2 LIMITS.
5. INSTALL BOLLARDS WITHIN STAGE 2 LIMITS.
6. REMOVE AND REPLACE FULL DEPTH PAVEMENT AS SHOWN IN THE PLANS WITHIN STAGE 2 LIMITS.
7. PLACE AGGREGATE BASE AND PCC PAVEMENT AS SHOW IN THE PLANS WITHIN STAGE 2 LIMITS.
8. GRADE AND LANDSCAPE WITHIN STAGE 2 LIMITS.

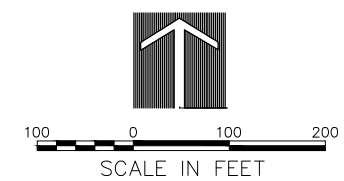
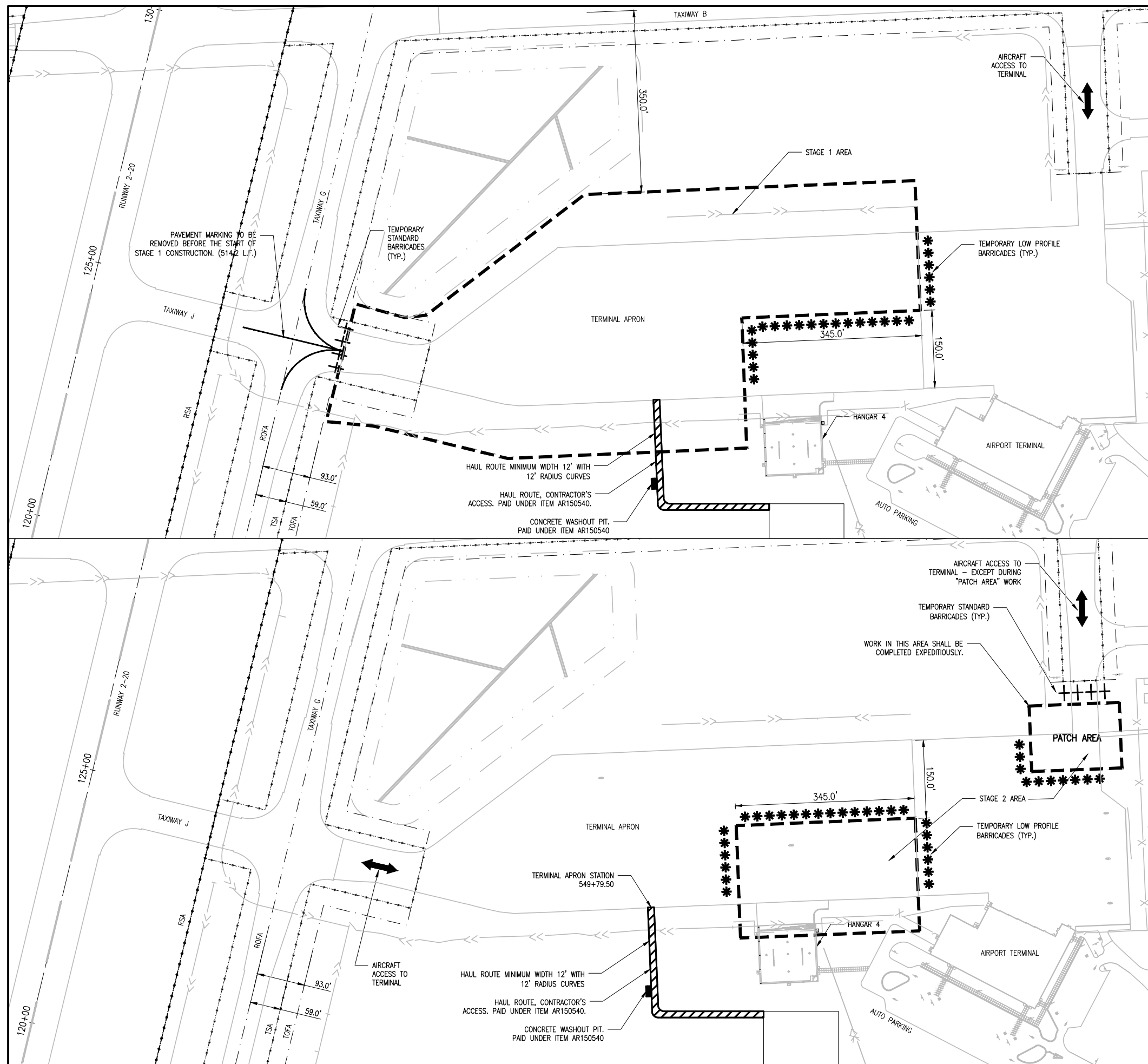

AIRCRAFT PARKING APRON REHABILITATION

IDA No: LOT-4298
SBG No: 3-17-SBGP-117
LE047

NO.	DATE	DESCRIPTION		
		LAY	DWN	REV

ISSUE: November 14, 2014
PROJECT NO: 13A0089
CAD FILE: 04-STAGING PLAN.DWG
LAYOUT BY: LDH 8/20/13
DRAWN BY: LDH 8/20/13
REVIEWED BY: RMH 11/14/14
© Copyright Hanson Professional Services Inc. 2011
SHEET TITLE

PHASING PLAN STAGE 1 AND 2

CONSTRUCTION AND SAFETY NOTES

SAFETY IS REQUIRED

CONSTRUCTION OF THE PROJECT SHALL BE PERFORMED IN ACCORDANCE WITH THE GUIDELINES SPECIFIED IN FAA ADVISORY CIRCULAR 150/5370-2 (CURRENT ISSUE) AND THE AIRPORT RULES AND REGULATIONS (AS PUBLISHED ON THE AIRPORT'S WEBSITE AT WWW.FLYLOT.COM, UNDER JRPD ORDINANCES AND MINUTES (EXCEPT FEES FOR VEHICLE DRIVING PERMITS SHALL NOT BE PAID)). ANY CONTRACTOR ACTIVITIES REQUIRED FOR PROJECT SAFETY SHALL BE INCIDENTAL TO THE CONTRACT.

SEQUENCE OF CONSTRUCTION

TO MINIMIZE DISRUPTIONS TO AIRPORT OPERATIONS, CONSTRUCTION OPERATIONS MUST BE CONTROLLED THROUGHOUT THE PROJECT'S DURATION AND WORK MUST BE COMPLETED EXPEDITIOUSLY. A CONSTRUCTION STAGING PLAN DETAILING THE SEQUENCING OF THE CONTRACTOR'S WORK THROUGHOUT THE PROJECT IS INCLUDED IN THE PLANS. THE CONTRACTOR SHALL PROVIDE HIS WRITTEN ACCEPTANCE OF THE PROJECT CONSTRUCTION STAGING PLAN AT THE PRE-CONSTRUCTION CONFERENCE. ANY AND ALL CHANGES TO THE CONSTRUCTION STAGING PLAN THAT MAY BE REQUESTED BY THE CONTRACTOR MUST BE APPROVED BY THE PROJECT ENGINEER AND THE AIRPORT OWNER. IT SHALL BE THE CONTRACTOR'S RESPONSIBILITY TO PROVIDE SUFFICIENT ADVANCE NOTICE OF ANY PROPOSED STAGING CHANGE TO PERMIT CONSIDERATION AND APPROVAL BY THE PROJECT ENGINEER AND THE AIRPORT OWNER. THE CONTRACTOR SHALL NOT BE ENTITLED TO ANY EXTRA COMPENSATION NOR EXTENSION TO THE CONTRACT TIME BECAUSE OF A STAGING CHANGE REQUEST NOR FOR ANY TIME NECESSARY IN RECEIVING THE REQUIRED APPROVALS.

LATHING AND WARNING TAPE

THE PROJECT WILL REQUIRE THE PLACEMENT OF LATHING AND WARNING TAPE TO DELINEATE THE WORK AREA FROM ACTIVE AIRPORT OPERATIONS AREAS. IT SHALL BE THE CONTRACTOR'S RESPONSIBILITY TO PROVIDE, PLACE AND MAINTAIN LATHING AND WARNING TAPE SHOWN ON THE STAGING PLAN ON SHEET 4 AND IN DETAIL A, THIS SHEET, AND AS DIRECTED BY THE RESIDENT ENGINEER AND THE AIRPORT DIRECTOR. THE CONTRACTOR WILL FURNISH, PLACE, MAINTAIN AND RELOCATE THE LATHING AND WARNING TAPE AS REQUIRED. THE COST OF THESE ITEMS, AND THEIR MAINTENANCE, IS TO BE INCIDENTAL TO THE CONTRACT.

TEMPORARY BARRICADES ON AIRFIELD

THE PROJECT WILL REQUIRE THE PLACEMENT OF BARRICADES TO DELINEATE PORTIONS OF THE CONSTRUCTION AREA AND TO EFFECT TEMPORARY CLOSURES OF TAXIWAYS AND APRONS. IT WILL BE THE CONTRACTOR'S RESPONSIBILITY TO FURNISH, PLACE AND MAINTAIN BARRICADES AS SHOWN ON THE STAGING PLAN ON SHEET 4 AND IN DETAILS B AND C, THIS SHEET, AND AS DIRECTED BY THE RESIDENT ENGINEER AND AIRPORT DIRECTOR. THE COST OF THESE ITEMS, AND THEIR MAINTENANCE, IS TO BE PAID UNDER ITEM AR150530. ANY WORK THAT REQUIRES PORTIONS OF AN ACTIVE TAXIWAY OR APRON TO BE CLOSED MUST BE COMPLETED EXPEDITIOUSLY TO MINIMIZE DISRUPTION TO AIRCRAFT OPERATIONS.

RUNWAY CLOSURE

NO RUNWAY CLOSURES WILL BE ALLOWED AS PART OF THE PROJECT.

VEHICULAR TRAFFIC CONTROL

THE CONTRACTOR SHALL ERECT AND MAINTAIN AT NO COST TO THE CONTRACT, DIRECTIONAL AND INFORMATIONAL SIGNS FOR THE CONTRACTOR'S ACCESS ROUTE ON THE AIRPORT AND FOR THE CONTRACTOR'S ROUTE WITHIN THE PROJECT SITE, AS NOTED ON THE PLANS OR AS DIRECTED BY THE RESIDENT ENGINEER AND AIRPORT OWNER. NO HAUL VEHICLES SHALL USE ANY AIRPORT ROADS EXCEPT AS SHOWN.

THE CONTRACTOR SHALL SECURE ANY PERMITS FOR HAULING ON LOCAL STREET OR STATE HIGHWAYS AS REQUIRED.

AIRFIELD OPERATIONAL SAFETY DURING CONSTRUCTION

ALL CONSTRUCTION TRAFFIC AND PERSONNEL SHALL REMAIN WITHIN THE CONSTRUCTION LIMIT LINE SHOWN ON THE STAGING PLAN FOR THE STAGE CURRENTLY UNDER CONSTRUCTION. CONTRACTOR'S PERSONNEL AND EQUIPMENT MUST REMAIN AT LEAST 250 FEET FROM THE CENTERLINE OF ACTIVE RUNWAY 9-27 AND 250 FEET FROM ACTIVE RUNWAY 2-20, 1000 FEET FROM THE END OF ACTIVE RUNWAYS, 65.5 FEET FROM THE CENTERLINE OF ACTIVE CATEGORY II TAXIWAYS AND 93 FEET FROM THE CENTERLINE OF ACTIVE CATEGORY III TAXIWAYS, 44.5 FEET FROM T-HANGAR TAXILANES AND 10 FEET FROM THE EDGE OF ACTIVE APRONS.

WHEN IT IS NECESSARY FOR CONSTRUCTION VEHICLES TO OPERATE ON OR WITHIN THESE LIMITS, THE RUNWAY, TAXIWAYS OR APRON MUST BE CLOSED. WHEN HAUL VEHICLES ARE PERMITTED TO CROSS ACTIVE TAXIWAYS, THE CONTRACTOR WILL PROVIDE POSITIVE CONTROL OF CONSTRUCTION VEHICLES USING RADIO-EQUIPPED FLAGGERS. ALL CONTRACTOR'S EQUIPMENT USED IN ACTIVE AIRPORT OPERATIONS AREAS SHALL BE EQUIPPED WITH A FAA-STANDARD FLAG, AS REFERENCED IN FAA AC 150/5370-2, CURRENT ISSUE. AIRCRAFT SHALL HAVE THE RIGHT-OF-WAY. CONSTRUCTION VEHICLES SHALL NOT CROSS AN ACTIVE RUNWAY. THE COST OF ALL TRAFFIC CONTROL, BOTH WITHIN AND OUTSIDE OF AIRPORT OPERATIONS AREAS, IS TO BE INCIDENTAL TO THE CONTRACT.

SHOULD ANY CONTRACTOR PERSONNEL BE IDENTIFIED AS NONCOMPLIANT WITH ANY VEHICLE DRIVING SAFETY REQUIREMENTS IN THIS SAFETY PLAN OR IN THE AIRPORT RULES AND REGULATIONS, SUCH DRIVERS SHALL BE PENALIZED BY RESCISSION OF THEIR ON-AIRPORT DRIVING PRIVILEGES, AND THEIR ACCESS TO THE CONSTRUCTION LIMIT AREA WHEN OPERATING VEHICLES SHALL BE REVOKED.

WHEN NOT IN USE AND DURING NONWORKING HOURS, CONTRACTOR'S EQUIPMENT SHALL BE PARKED WITHIN THE CONTRACTOR'S EQUIPMENT STORAGE AND PARKING AREAS. THE EQUIPMENT STORAGE AND PARKING AREAS ARE TO BE LOCATED AS SHOWN ON THE STAGING PLAN. THE CONTRACTOR WILL BE RESPONSIBLE FOR MAINTAINING THE CONSTRUCTION AREA IN GOOD CONDITION. THE COST OF MAINTAINING THE CONSTRUCTION ENTRANCE IS TO BE INCIDENTAL TO THE CONTRACT.

AT NO TIME SHALL THE CONTRACTOR OPERATE OR PARK EQUIPMENT SO AS TO OBSTRUCT AN ACTIVE RUNWAY IMAGINARY SURFACE.

OPEN TRENCHES, EXCAVATIONS AND STOCKPILED MATERIAL AT THE CONSTRUCTION SITE SHALL BE DELINEATED WITH THE USE OF BARRICADES DURING HOURS OF RESTRICTED VISIBILITY AND/OR DARKNESS. NO OPEN TRENCHES SHALL BE ALLOWED WITHIN THE RUNWAY SAFETY AREA (RSA) OR THE TAXIWAY SAFETY AREA (TSA) OVER NIGHT. THE RSA IS DEFINED AS 75 FEET FROM THE RUNWAY 9-27 CENTERLINE AND 300 FEET FROM THE END OF RUNWAY 9-27 AND 250 FEET FROM THE RUNWAY 2-20 CENTERLINE AND 1000 FEET FROM THE END OF RUNWAY 2-20. THE TSA IS MEASURED AT 24.5 FEET FROM THE CATEGORY I TAXIWAY CENTERLINE, 39.5 FEET FROM THE CATEGORY II TAXIWAY CENTERLINE AND 59 FEET FROM THE CATEGORY III CENTERLINE. THE CONTRACTOR SHALL HAVE STEEL PLATES ON-SITE TO ALLOW FOR THE RAPID COVERING OF TRENCHES IN THE EVENT OF UNEXPECTED WORK STOPPAGES FOR WEATHER OR AIRPORT EMERGENCIES.

BEFORE REOPENING TEMPORARILY CLOSED RUNWAYS, TAXIWAYS OR ROADWAYS, THE CONTRACTOR SHALL INSPECT AND CLEAN, AS NECESSARY, THE PAVEMENT TO ASSURE THAT NO MATERIALS OR OBJECTS THAT MAY DAMAGE AIRCRAFT OR VEHICLES REMAIN. ANY REQUIRED CLEANING SHALL BE TO THE SATISFACTION OF THE RESIDENT ENGINEER AND AIRPORT OWNER AND IS INCIDENTAL TO THE CONTRACT.

ALL CONTRACTOR EQUIPMENT IS LIMITED TO A HEIGHT OF 25 FEET.

NOTIFICATIONS BY CONTRACTOR

THE CONTRACTOR SHALL NOTIFY THE RESIDENT ENGINEER AND AIRPORT OWNER 5 DAYS IN ADVANCE OF THE CONTRACTOR'S CLOSING OF ACTIVE TAXIWAYS AND APRONS. THE DATE, TIME AND SCHEDULED DURATION OF THE CLOSING MUST BE APPROVED BY THE RESIDENT ENGINEER AND THE AIRPORT OWNER. THE CONTRACTOR SHALL NOTIFY THE RESIDENT ENGINEER AND AIRPORT OWNER 72 HOURS IN ADVANCE OF THE CONTRACTOR'S CLOSING OF OTHER ACTIVE ROADWAYS, AIRFIELD OR ROADWAY LIGHTING CIRCUITS, OR OTHER AIRPORT FACILITIES.

CONTRACTOR'S USE OF SITE

THE CONTRACTOR SHALL NOT OPERATE WITHIN, ENCROACH UPON OR OBSTRUCT AIRPORT OPERATIONAL AREAS, INCLUDING ACTIVE RUNWAY, TAXIWAYS AND APRON SAFETY AREAS, OBJECT AND OBSTACLE FREE ZONES, RUNWAY PROTECTION ZONES AND AIRPORT IMAGINARY SURFACES AS DEFINED IN FEDERAL AVIATION REGULATIONS (FAR) PART 77, "OBJECTS AFFECTING NAVIGABLE AIRSPACE".

THE CONTRACTOR IS RESPONSIBLE FOR RESTORATION OF THE WORK AREA PRIOR TO BEGINNING WORK AT A NEW LOCATION.

UTILITY OUTAGES AND SHUTDOWNS

THE CONTRACTOR SHALL PROVIDE 72 HOURS PRIOR NOTICE OF ANY OUTAGES OR SHUTDOWNS TO THE OWNER AND THE AGENCY OWNING THE AFFECTED UTILITY. THE CONTRACTOR SHALL PROVIDE ANY TEMPORARY CONNECTIONS OR OTHER MEASURES AS MAY BE REQUIRED TO MAINTAIN SERVICE AS MAY BE REQUIRED BY THE OWNING AGENCY AT NO COST TO THE OWNER.

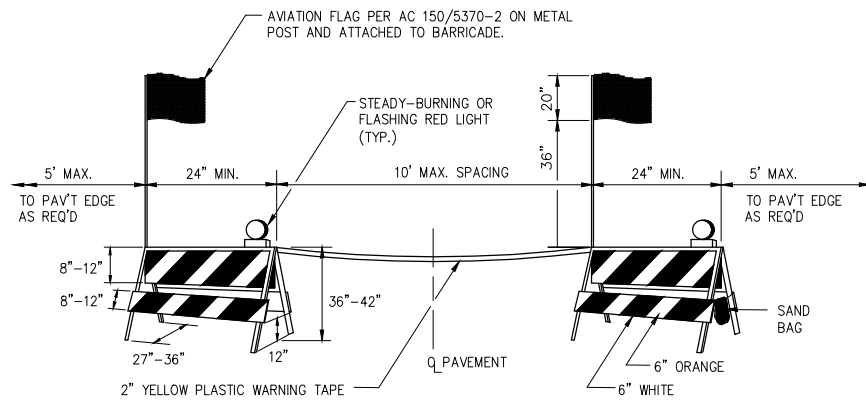

BARRICADES ARE TO BE OF IDOT TYPE I. A STEADY-BURNING OR FLASHING RED LIGHT FACING PASSING TRAFFIC IS TO BE MOUNTED ABOVE THE TOP OF EACH BARRICADE FRAME. THE BARRICADE IS TO BE STABILIZED FROM WIND BY SANDBAGS PLACED ON THE FRAME OR OTHER METHODS APPROVED BY THE RESIDENT ENGINEER. NO PART OF THE REFLECTORIZED PORTION OF THE BARRICADE IS TO BE OBSTRUCTED IN ANY MANNER. COST OF FURNISHING, INSTALLING, RELOCATING, MAINTAINING AND REMOVING BARRICADES IS TO BE PAID UNDER ITEM AR150530.

DETAIL B PAVEMENT BARRICADES

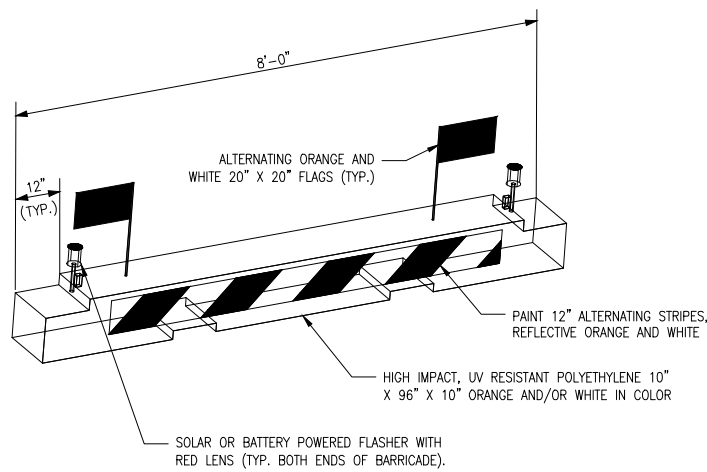

NOTES:

1. INTENDED USE FOR THE FOLLOWING:
 - MARKING/LIGHTING OF TEMPORARY HAZARDS WITHIN THE AOA.
 - LONGTERM CLOSURE OF AIRCRAFT ROUTES.
2. INSTALL AT 12" CENTER TO CENTER SPACING ALONG FULL WIDTH OF PAVEMENT.
3. USE TYPE 2 AIRCRAFT BARRICADES IN AREAS SUBJECT TO JET BLAST.
4. BARRICADE SHALL BE EQUIPPED WITH ALTERNATING ORANGE AND WHITE 20" X 20" FLAGS.
5. BARRICADES SHALL BE WATER-FILLED AND MODULAR TO ASSEMBLE/DISASSEMBLE AND NEST FOR COMPACT STORAGE.
6. CONTRACTOR MAY SUBMIT ALTERNATIVE BARRICADE FOR APPROVAL BY ENGINEER. ALTERNATIVE MUST MEET MINIMUM REQUIREMENTS OF FAA AC 150/5370-2F (LATEST EDITION).
7. FURNISHING, INSTALLING, MAINTAINING AND REMOVING BARRICADES SHALL BE PAID UNDER ITEM AR150530. SEE SPECIAL PROVISIONS.
8. CONTRACTOR SHALL MAINTAIN THE BARRICADES. ANY DAMAGED BARRICADES SHALL BE REPLACED AND NEW BARRICADES PROVIDED.

DETAIL C TYPE 2 - LOW PROFILE AIRCRAFT BARRICADE DETAIL

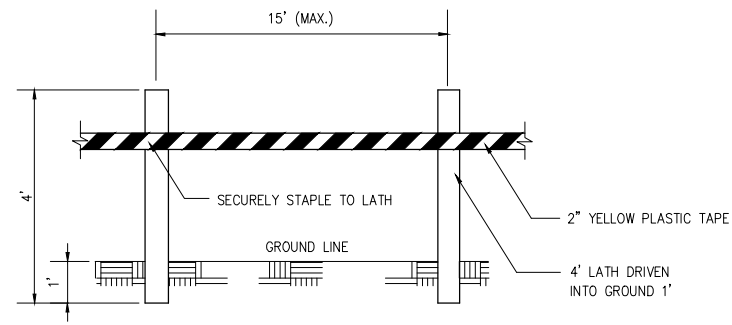

MATERIALS ARE TO BE APPROVED BY ENGINEER PRIOR TO INSTALLATION. COST OF MATERIALS, INSTALLATION, RELOCATION AND MAINTENANCE OF LATHING AND WARNING TAPE IS TO BE INCIDENTAL TO THE CONTRACT.

DETAIL A LATHING AND WARNING TAPE

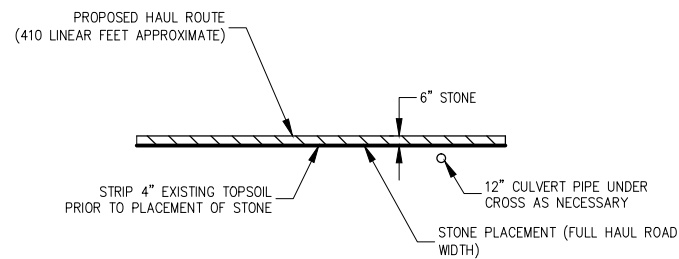

CROSS SECTION

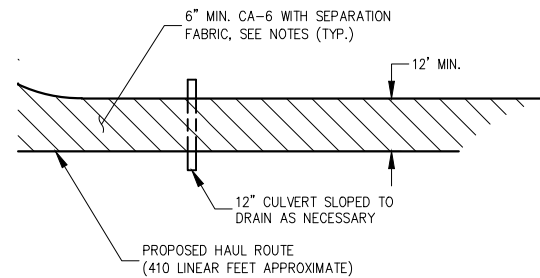

PLAN

NOTES:

1. STRIP 4" OF EXISTING TOPSOIL PRIOR TO PLACEMENT OF STONE.
2. STONE SHALL BE 2-INCH SIZE, OR RECLAIMED OR RECYCLED CONCRETE EQUIVALENT, OR RECYCLED ASPHALT.
3. HAUL ROUTE THICKNESS SHALL NOT BE LESS THAN SIX INCHES.
4. HAUL ROUTE WIDTH SHALL BE 12 FEET MINIMUM.
5. SURFACE WATER FLOWING OR DIVERTED SHALL BE CARRIED IN CULVERT (CMP, STEEL OR HDPE).
6. PLACE SEPARATION FABRIC PRIOR TO STONE PLACEMENT FOR FULL WIDTH OF HAUL ROUTE. FABRIC TO BE MIRAFI 160N OR APPROVED EQUAL, COST INCIDENTAL TO ITEM AR150540.
7. A CONCRETE WASHOUT PIT TO PROHIBIT STORM WATER DISCHARGE SHALL ALSO BE FURNISHED, AND SHALL BE BUILT MEETING THE REQUIREMENTS OF THE ILLINOIS URBAN MANUAL.
8. THE HAUL ROUTE SHALL BE MAINTAINED IN A CONDITION WHICH WILL PREVENT TRACKING OR FLOWING OF SEDIMENT ONTO AIRPORT PAVEMENTS OR PUBLIC RIGHT-OF-WAYS. THIS MAY REQUIRE PERIODIC TOP DRESSING WITH ADDITIONAL AGGREGATE AS CONDITIONS DEMAND AND REPAIR AND/OR CLEAN OUT OF ANY MEASURE USED TO TRAP SEDIMENT. ALL SEDIMENT SPILLED, DROPPED, WASHED OR TRACKED ONTO AIRPORT PAVEMENTS OR PUBLIC RIGHT-OF-WAYS MUST BE REMOVED IMMEDIATELY.
9. PERIODIC INSPECTION SHALL BE PERFORMED AND REQUIRED MAINTENANCE SHALL BE PROVIDED AFTER EACH RAIN EVENT.
10. HAUL ROUTE AND WASHOUT PIT TO BE REMOVED AT PROJECT END. AREA TO BE RESTORED AND RESEDED AND LEFT IN A CONDITION SATISFACTORY TO THE RESIDENT ENGINEER.
11. COST OF INSTALLING, MAINTAINING, REMOVING AND RESTORING HAUL ROUTE SHALL BE PAID UNDER ITEM AR150540.

DETAIL D HAUL ROUTE

NO.	DATE	DESCRIPTION		
		LAY	DWN	REV

ISSUE: November 14, 2014
PROJECT NO: 13A0089
CAD FILE: 05-SAFETY\NOTES.DWG
LAYOUT BY: LDH 8/20/13
DRAWN BY: LDH 8/20/13
REVIEWED BY: RMH 11/14/14
© Copyright Hanson Professional Services Inc. 2011
SHEET TITLE

CONSTRUCTION SAFETY NOTES AND DETAILS

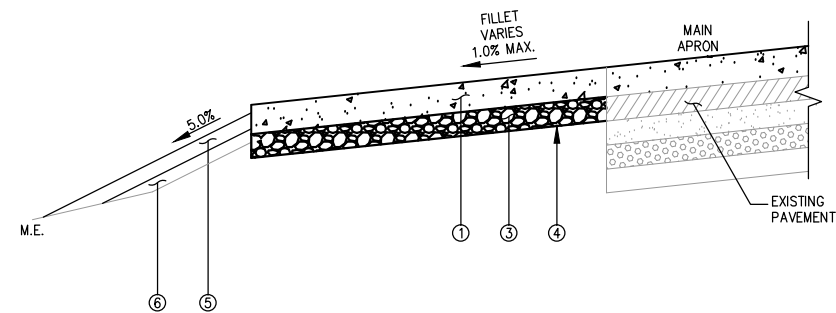

TYPICAL SECTION - FULL DEPTH FILLET
(SECTION SHOWN LOOKING NORTH)

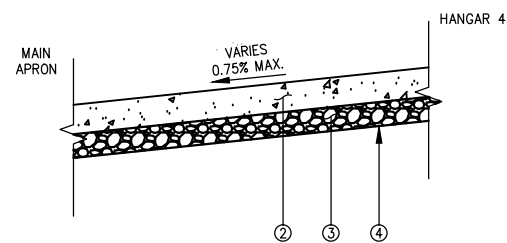

TYPICAL SECTION - HANGAR 4 APRON AREA
(SECTION SHOWN LOOKING EAST)

LEGEND:

- ① PROPOSED 10 INCH PCC PAVEMENT, NOMINAL, ITEM AR501510
- ② PROPOSED 8 INCH PCC PAVEMENT, NOMINAL, ITEM AR501508
- ③ PROPOSED 6 INCH GRANULAR DRAINAGE SUBBASE, ITEM ARB00927
- ④ PROPOSED SEPARATION FABRIC, ITEM AR156513
- ⑤ PROPOSED TOPSOIL, 4 INCH, ITEM AR905510 & AR905520
- ⑥ PROPOSED OFFSITE BORROW EXCAVATION, DEPTH VARIES, ITEM AR152442

NOTE:

* ITEM AR209510 SHALL BE PLACED AT SELECT LOCATIONS ON ALIGNMENT 3400+00. SEE CROSS SECTIONS FOR LOCATION.

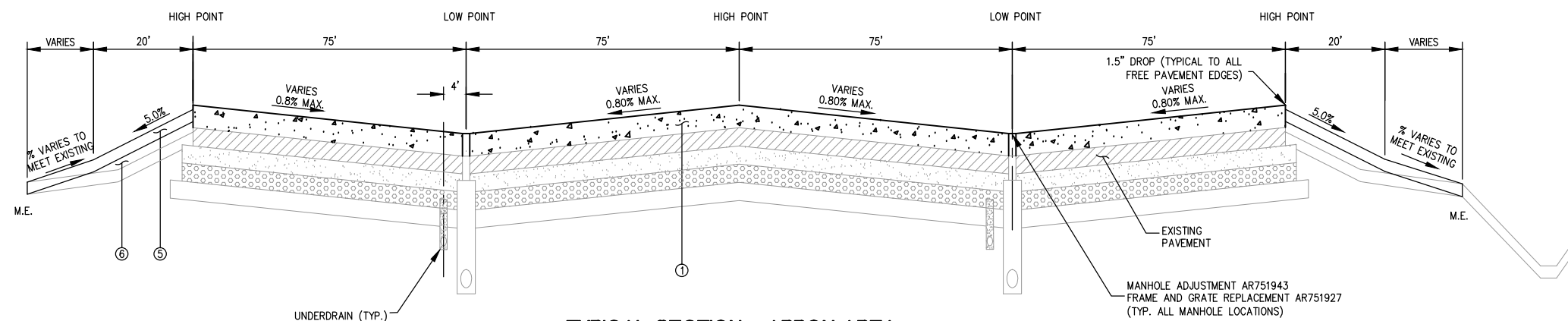

TYPICAL SECTION - APRON AREA
(SECTION SHOWN LOOKING EAST)

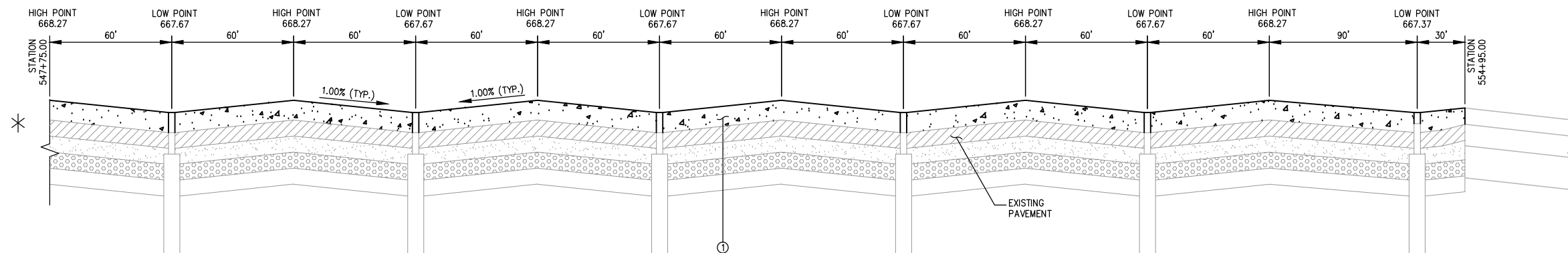

TYPICAL SECTION - APRON AREA
(SECTION SHOWN LOOKING NORTH)

AIRCRAFT PARKING APRON REHABILITATION

IDA No: LOT-4298
SBG No: 3-17-SBGP-117
LE047

NO.	DATE	DESCRIPTION		
		LAY	DWN	REV

ISSUE: November 14, 2014
PROJECT NO: 13A0089
CAD FILE: 06-TYPSECTION.DWG
LAYOUT BY: LDH 8/20/13
DRAWN BY: LDH 8/20/13
REVIEWED BY: RMH 11/14/14
© Copyright Hanson Professional Services Inc. 2011
SHEET TITLE

TYPICAL SECTIONS AND PAVEMENT DETAILS

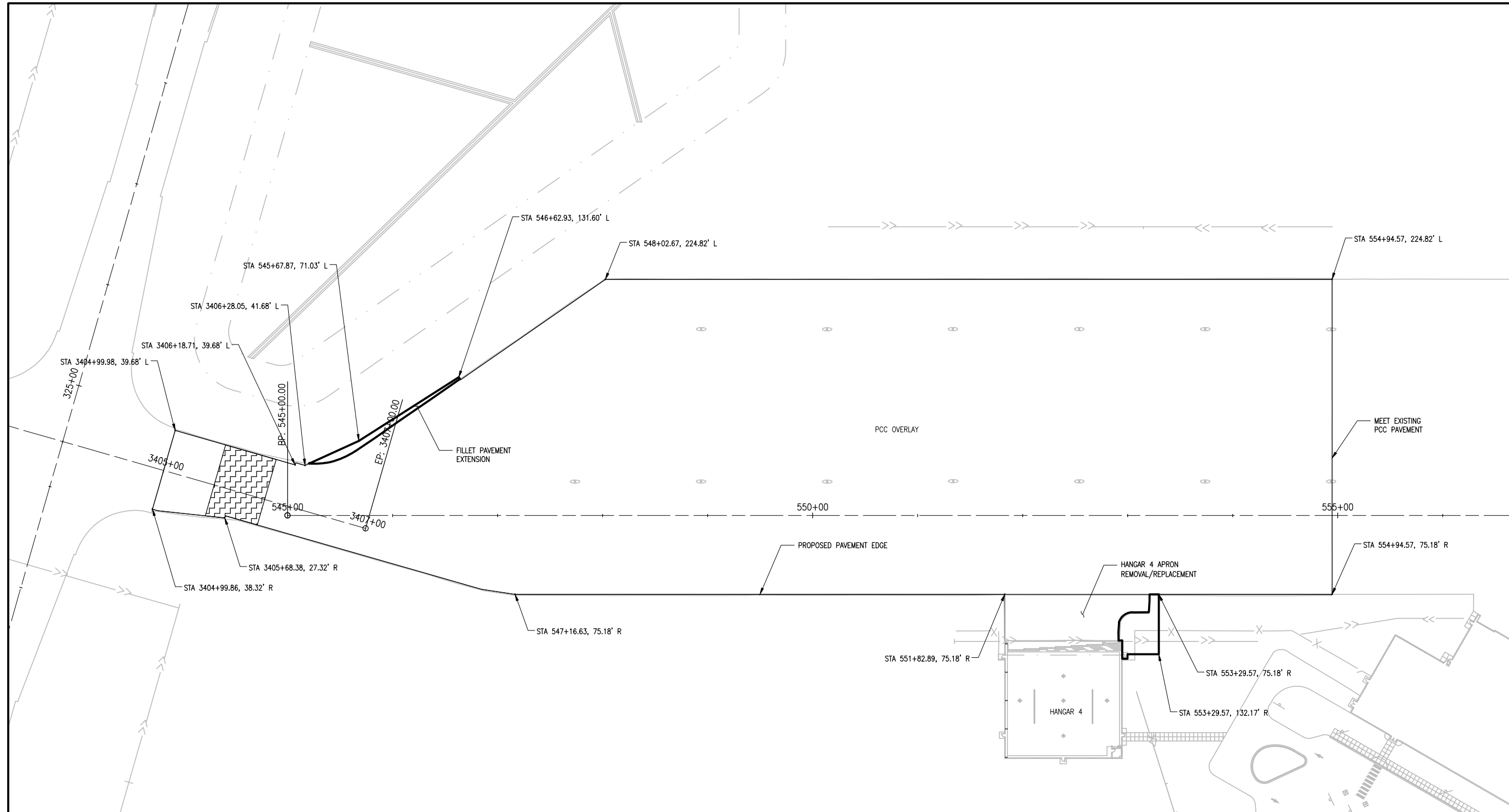

**AIRCRAFT PARKING
APRON
REHABILITATION**

IDA No: LOT-4298
SBG No: 3-17-SBGP-117
LE047

NO.	DATE	DESCRIPTION		
		LAY	DWN	REV

ISSUE: November 14, 2014
PROJECT NO: 13A0089
CAD FILE: 07-ALIGNMENT PLAN.DWG
LAYOUT BY: LDH 8/20/13
DRAWN BY: LDH 8/20/13
REVIEWED BY: RMH 11/14/14
© Copyright Hanson Professional Services Inc. 2011
SHEET TITLE

ALIGNMENT DATA

Alignment	Description	Station	Project Coordinates	
			Northing	Easting
Alignment 3400 Taxiway J	Beginning of Alignment	3400+00.00	1799019.3641	1048398.4142
	End of Alignment	3407+00.00	1798855.0538	1049078.8568
Alignment 545 Terminal Apron	Beginning of Alignment	545+00.00	1798864.2028	1049004.1474
	End of Alignment	559+50.00	1798925.5356	1050452.8497
Alignment 2200 Taxiway C	Beginning of Alignment	2208+00.00	1798795.5717	1050338.2441
	End of Alignment	2220+00.00	1799994.4977	1050287.4859
Alignment 270 Taxiway G	Beginning of Alignment	270+00.00	1793632.9877	1047509.2320
	End of Alignment	395+00.00	1805783.7480	1050443.3456

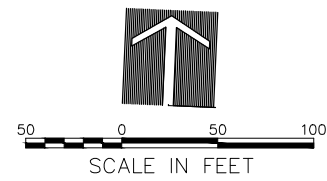

OCT 23, 2014, 8:36 AM HAUSM0682
I:\13A0089\08\4013A0089\DESIGN\DRAWINGS\SHEETS\07-ALIGNMENT PLAN.DWG

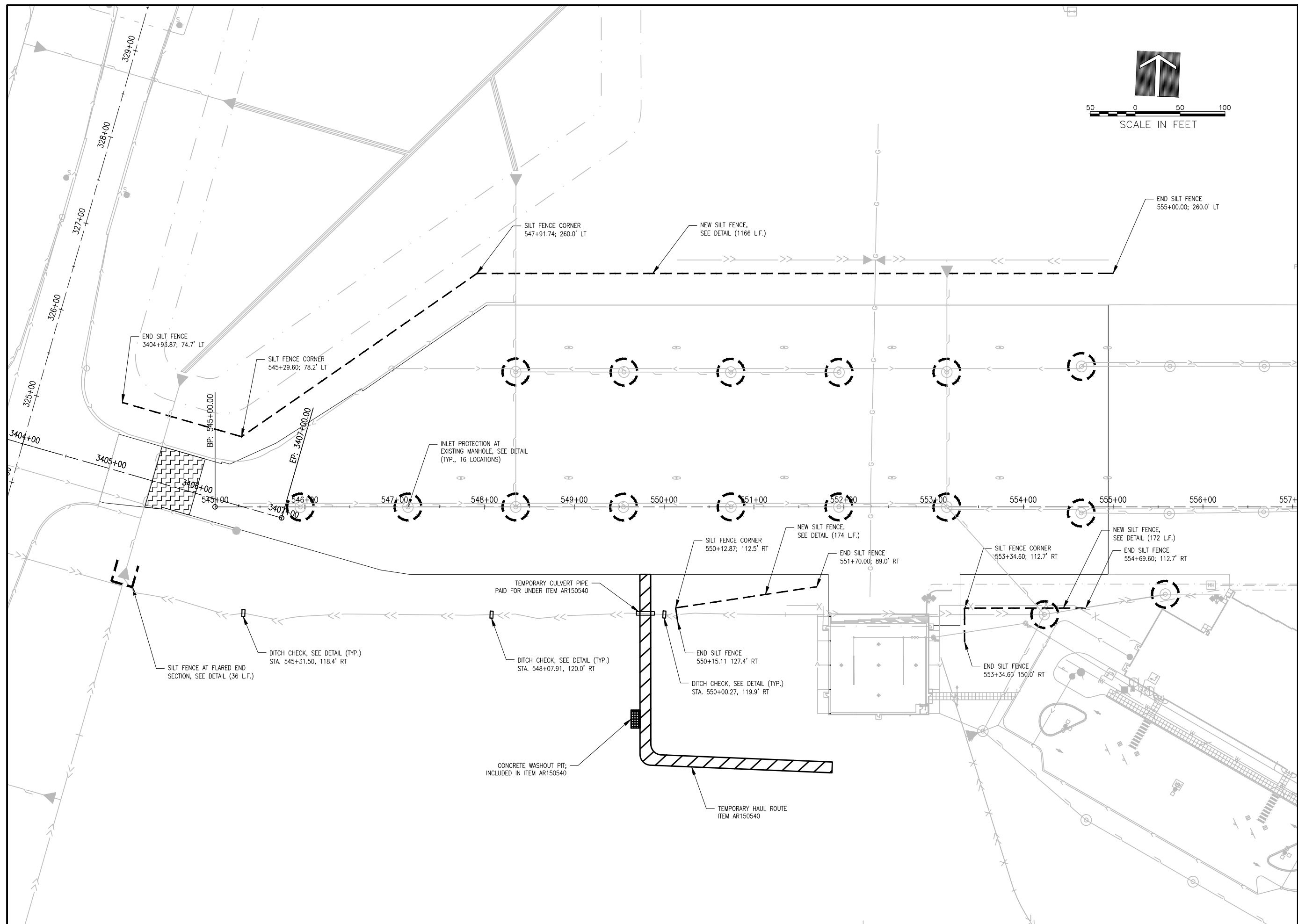
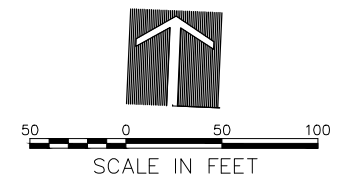

**AIRCRAFT PARKING
APRON
REHABILITATION**

IDA No: LOT-4298
SBG No: 3-17-SBGP-117
LE047

NO.	DATE	DESCRIPTION		
		LAY	DWN	REV

ISSUE: November 14, 2014
PROJECT NO: 13A0089
CAD FILE: 08-SWPP PLAN.DWG
LAYOUT BY: KMS 3/10/14
DRAWN BY: KMS 3/10/14
REVIEWED BY: RMH 11/14/14
© Copyright Hanson Professional Services Inc. 2011
SHEET TITLE

SWPP PLAN

OCT 23, 2014 8:37 AM HAUSM0682
I:\13\08\008401\3A0089\DESIGN\DRAWINGS\SHEETS\08-SWPP PLAN.DWG

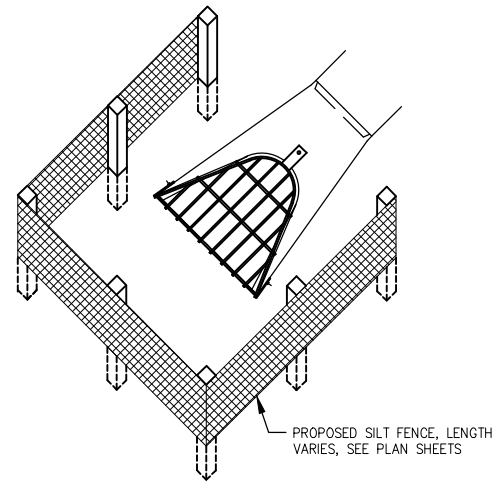

SILT FENCE PLACEMENT AT FLARED END SECTIONS (FES)

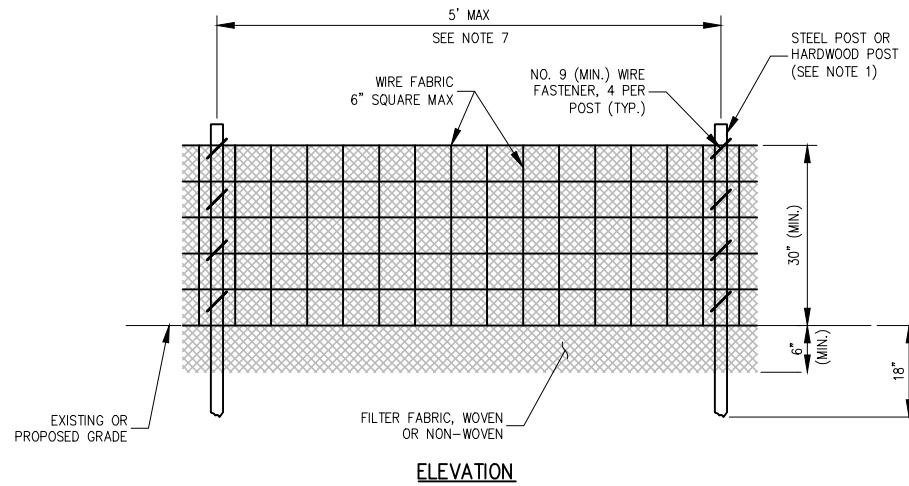

ELEVATION

NOTES:

- FENCE POST SHALL BE EITHER STEEL "1" LINE POST OR HARDWOOD POST WITH A MINIMUM SECTIONAL AREA OF 2.0 SQUARE INCHES. A CARPENTER'S (NOMINAL) 2"x2" POST WILL MEET SPECIFICATIONS.
- TOP AND BOTTOM WIRE OF WIRE FABRIC SHALL BE MINIMUM GAGE NO. 9. INTERMEDIATE WIRES OF THE WIRE FABRIC SHALL BE MINIMUM GAGE NO. 11.
- WIRE FABRIC SHALL BE SECURELY FASTENED TO FENCE POSTS WITH NO. 9 GAGE WIRE MINIMUM. FOUR (4) FASTENERS PER POST REQUIRED.
- FILTER FABRIC SHALL BE SECURELY FASTENED TO WIRE FABRIC AND POSTS WITH TIES OR STAPLES SPACED AT 12" APART AT THE TOP, MIDDLE AND BOTTOM.
- WHEN TWO SECTIONS OF FILTER FABRIC MEET, THEY SHALL BE OVERLAPPED BY 6" AND FOLDED AND ATTACHED TO THE WIRE FABRIC AT A POST.
- FILTER FABRIC SHALL BE IN ACCORDANCE WITH SPECIAL PROVISIONS WITH APPARENT OPENING SIZE (AOS) OF AT LEAST 40 FOR NONWOVEN AND WOVEN (OR MAXIMUM OF 0.60mm).
- A MAXIMUM OF 5 FEET IS USED FOR POST-TO-POST SPACING.
- SOIL DISTURBANCE SHALL BE CONDUCTED IN SUCH A MANNER AS TO MINIMIZE EROSION. SOIL STABILIZATION MEASURES SHALL CONSIDER THE TIME OF YEAR, SITE CONDITIONS AND THE USE OF TEMPORARY OR PERMANENT MEASURES.
- ALL STORM SEWERS THAT ARE OR WILL BE FUNCTIONING DURING CONSTRUCTION SHALL BE PROTECTED BY AN APPROPRIATE SEDIMENT CONTROL MEASURE.
- SILT FENCE SHALL BE INSTALLED PRIOR TO ANY GRADING WORK IN THE AREA TO BE PROTECTED. PERIODIC INSPECTION SHALL BE PERFORMED AND REQUIRED MAINTENANCE SHALL BE PROVIDED AFTER EACH RAIN EVENT.
- MAINTENANCE SHALL BE PERFORMED AS NEEDED AND MATERIAL REMOVED AND REPLACED WHEN BULGES DEVELOP IN THE SILT FENCE.
- IF DEWATERING SERVICES ARE USED, ADJOINING PROPERTIES AND DISCHARGE LOCATIONS SHALL BE PROTECTED FROM EROSION. DISCHARGES SHALL BE ROUTED THROUGH AN EFFECTIVE SEDIMENT CONTROL MEASURE (E.G. SEDIMENT TRAP, SEDIMENT BASIN, OR OTHER APPROPRIATE MEASURE).
- FENCE POSTS SHALL BE REMOVED WHEN DIRECTED AT PROJECT END.
- THE EROSION CONTROL MEASURES INDICATED ON THE PLANS ARE THE MINIMUM REQUIREMENTS. ADDITIONAL MEASURES MAY BE REQUIRED, AS DIRECTED BY THE ENGINEER OR GOVERNING AGENCY.

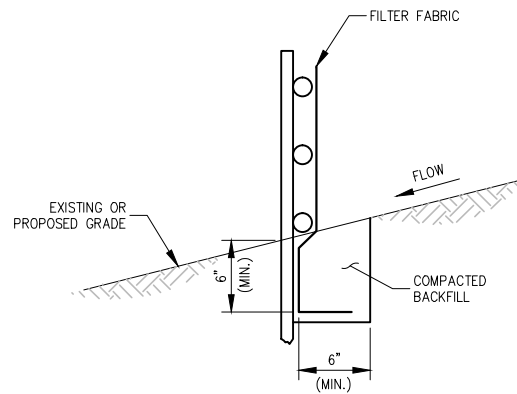

FABRIC ANCHOR DETAIL

SILT FENCE DETAILS

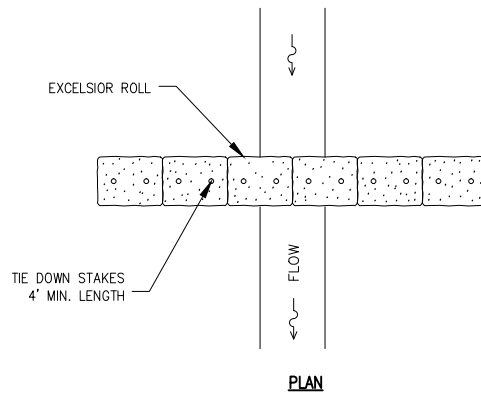

PLAN

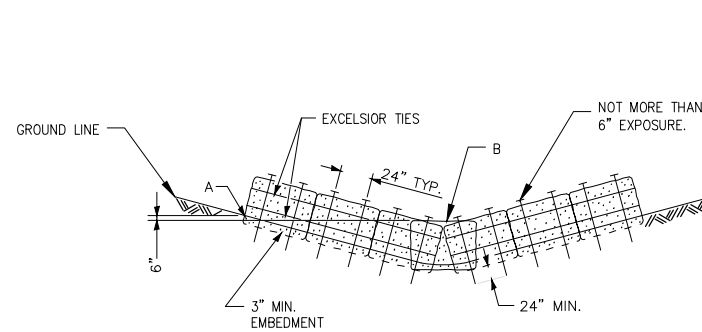

ELEVATION

NOTES:

- PT. A HIGHER THAN PT. B
- DIAMETER OF EXCELSIOR ROLL IS 15".

DITCH CHECK

SEDIMENTATION AND EROSION CONTROL NOTES:

- SOIL DISTURBANCE SHALL BE CONDUCTED IN SUCH A MANNER AS TO MINIMIZE EROSION. SOIL STABILIZATION MEASURES SHALL CONSIDER THE TIME OF YEAR, SITE CONDITIONS AND THE USE OF TEMPORARY OR PERMANENT MEASURES.
- SOIL EROSION AND SEDIMENT CONTROL FEATURES SHALL BE CONSTRUCTED PRIOR TO THE COMMENCEMENT OF HYDROLOGIC DISTURBANCE OF UPLAND AREAS.
- DISTURBED AREAS SHALL BE STABILIZED WITH TEMPORARY OR PERMANENT MEASURES WITHIN 14 CALENDAR DAYS OF THE END OF ACTIVE HYDROLOGIC DISTURBANCE, OR REDISTURBANCE.
- AREAS OR EMBANKMENTS HAVING SLOPES GREATER THAN OR EQUAL TO 3H:1V, AND APPROVED BY THE ENFORCEMENT OFFICER, SHALL BE STABILIZED WITH SOD, MAT OR BLANKET IN COMBINATION WITH SEEDING.
- EROSION CONTROL BLANKET SHALL BE REQUIRED ON ALL INTERIOR DETENTION BASIN SIDE SLOPES BETWEEN NORMAL WATER LEVEL AND HIGH WATER LEVEL.
- ALL STORM SEWERS THAT ARE OR WILL BE FUNCTIONING DURING CONSTRUCTION SHALL BE PROTECTED, BY AN APPROPRIATE SEDIMENT CONTROL MEASURE.
- ALL TEMPORARY EROSION AND SEDIMENT CONTROL MEASURES SHALL BE REMOVED WITHIN 30 DAYS AFTER FINAL SITE STABILIZATION IS ACHIEVED OR AFTER THE TEMPORARY MEASURES ARE NO LONGER NEEDED.
- ALL TEMPORARY AND PERMANENT EROSION CONTROL MEASURES MUST BE MAINTAINED AND REPAIRED AS NEEDED. THE PROPERTY OWNER SHALL BE ULTIMATELY RESPONSIBLE FOR MAINTENANCE AND REPAIR.
- A STABILIZED MAT OF AGGREGATE UNDERLAIN WITH FILTER CLOTH (OR OTHER APPROPRIATE MEASURE) SHALL BE LOCATED AT ANY POINT WHERE TRAFFIC WILL BE ENTERING OR LEAVING A CONSTRUCTION SITE TO OR FROM A PUBLIC RIGHT-OF-WAY, STREET, ALLEY OR PARKING AREA. ANY SEDIMENT OR SOIL REACHING AN IMPROVED PUBLIC RIGHT-OF-WAY, STREET, ALLEY OR PARKING AREA SHALL BE REMOVED BY SCRAPING OR STREET CLEANING AS ACCUMULATIONS WARRANT AND TRANSPORTED TO A CONTROLLED SEDIMENT DISPOSAL AREA.
- SOIL STOCKPILES SHALL NOT BE LOCATED IN A FLOOD PRONE AREA OR A DESIGNATED BUFFER PROTECTING WATERS OF THE UNITED STATES OR ISOLATED WATERS OF LAKE COUNTY.
- IF DEWATERING SERVICES ARE USED, ADJOINING PROPERTIES AND DISCHARGE LOCATIONS SHALL BE PROTECTED FROM EROSION. DISCHARGES SHALL BE ROUTED THROUGH AN EFFECTIVE SEDIMENT CONTROL MEASURE (E.G. SEDIMENT TRAP, SEDIMENT BASIN, OR OTHER APPROPRIATE MEASURE).
- THE EROSION CONTROL MEASURES INDICATED ON THE PLANS ARE THE MINIMUM REQUIREMENTS. ADDITIONAL MEASURES MAY BE REQUIRED, AS DIRECTED BY THE ENGINEER OR GOVERNING AGENCY.

STORM WATER POLLUTION PREVENTION NOTES

GENERAL

THE CONTRACTOR SHALL IMPLEMENT ALL PROVISIONS OF THE CONTRACT DOCUMENTS TO ASSURE THAT STORM WATER POLLUTION PREVENTION ITEMS ARE CONSTRUCTED AND MAINTAINED IN A TIMELY MANNER. SEDIMENTATION MUST NOT BE TRANSPORTED OFF THE CONSTRUCTION SITE. PERMANENT DRAINAGE FEATURES AND VEGETATIVE MEASURES SHALL BE PROVIDED AS SOON AS POSSIBLE.

THE MAINTENANCE OF ALL STORM WATER POLLUTION PREVENTION MEASURES IS INCIDENTAL TO THE ASSOCIATED ITEM.

POLLUTION PREVENTION MEASURES

THE CONTRACTOR SHALL BE REQUIRED TO IMPLEMENT AND MAINTAIN STORM WATER POLLUTION PREVENTION PRACTICES AND MEASURES PRIOR TO THE STRIPPING OF EXISTING VEGETATION WHERE EVER POSSIBLE AND AS SOON AS CONSTRUCTION PERMITS IN OTHER AREAS. POLLUTION CONTROL MEASURES SHALL BE IN ACCORDANCE WITH THE CONTRACT DOCUMENTS, INCLUDING THESE CONSTRUCTION PLANS, AND WITH STANDARDS AND SPECIFICATIONS FOR SOIL EROSION AND SEDIMENT CONTROL, ILLINOIS ENVIRONMENTAL PROTECTION AGENCY, CURRENT ISSUE. THE CONTRACTOR SHALL ADJUST HIS OPERATIONS AND IMPLEMENT POLLUTION CONTROL MEASURES SO THAT NO RUNOFF FROM STRIPPED AREAS WILL LEAVE THE CONSTRUCTION SITE OTHER THAN THROUGH SEDIMENT TRAPS OR OTHER SUITABLE CONTROL MEASURES.

POLLUTION CONTROL ITEMS SHALL BE PROVIDED AS NOTED ON THE STORM WATER POLLUTION PREVENTION PLAN AND IN THE STORM WATER POLLUTION PREVENTION DETAILS AND AS DIRECTED BY THE ENGINEER. THE LIMITS OF SUCH MEASURES SHALL BE STAKED BY THE CONTRACTOR PRIOR TO THE COMMENCEMENT OF CONSTRUCTION. SUCH LIMITS MAY BE ADJUSTED BY THE ENGINEER TO ACCOUNT FOR ACTUAL SITE CONDITIONS EXPERIENCED DURING CONSTRUCTION. ADDITIONAL COMPENSATION FOR MEASURES EXCEEDING THE PLAN QUANTITIES WILL BE PAID FOR AT THE CONTRACT UNIT PRICE FOR EACH ITEM.

THE CONTRACTOR IS TO MAINTAIN AND ADJUST, REPAIR OR REPLACE ALL POLLUTION PREVENTION MEASURES AS REQUIRED OR AS DIRECTED BY THE ENGINEER UNTIL PERMANENT VEGETATION HAS BEEN ESTABLISHED. MAINTENANCE OF POLLUTION CONTROL MEASURES IS TO BE PROVIDED AT NO ADDITIONAL COST TO THE CONTRACT.

ADDITIONAL STORMWATER POLLUTION PREVENTION MEASURES ARE EXISTING ON SITE LOCATED AT DRAINAGE FACILITIES AND ALONG THE PROPERTY LINE.

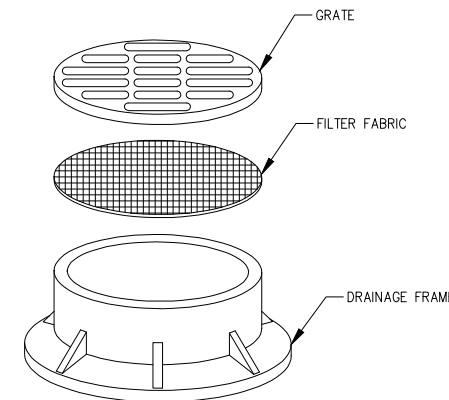

NOTES:

- FILTER WRAP TO BE PLACED IN ALL MANHOLES AS SHOWN.
- FABRIC SHALL BE IN CONFORMANCE WITH MATERIALS SPECIFIED FOR SILT FENCE.
- FABRIC SHALL OVERLAY FRAME BY 2 INCHES (MINIMUM).
- CONTRACTOR SHALL CLEAR DEBRIS AND SILT AS REQUIRED FROM FABRIC TO MAINTAIN DRAINAGE THROUGH THE STRUCTURE.
- FABRIC SHALL REMAIN IN PLACE UNTIL TURFED AREAS HAVE DEVELOPED A MINIMUM OF 90% OF COVERAGE.
- COST OF FILTER WRAP SHALL BE INCIDENTAL TO INLET PROTECTION.

INLET PROTECTION - DRAINAGE STRUCTURE FILTER WRAP

AIRCRAFT PARKING APRON REHABILITATION

IDA No: LOT-4298
SBG No: 3-17-SBGP-117
LE047

NO.	DATE	DESCRIPTION		
		LAY	DWN	REV

ISSUE: November 14, 2014
PROJECT NO: 13A0089
CAD FILE: 09-SWPP DET.DWG
LAYOUT BY: KMS 3/10/14
DRAWN BY: KMS 3/10/14
REVIEWED BY: RMH 11/14/14
© Copyright Hanson Professional Services Inc. 2011
SHEET TITLE

SWPPP DETAILS

**AIRCRAFT PARKING
APRON
REHABILITATION**

IDA No: LOT-4298
SBG No: 3-17-SBGP-117
LE047

NO.	DATE	DESCRIPTION			
			LAY	DWN	REV

ISSUE: November 14, 2014
PROJECT NO: 13A0089
CAD FILE: 10-REMOVAL PLAN.DWG
LAYOUT BY: KMS 3/10/14
DRAWN BY: KMS 3/10/14
REVIEWED BY: RMH 11/14/14
© Copyright Hanson Professional Services Inc. 2011
SHEET TITLE

REMOVAL PLAN

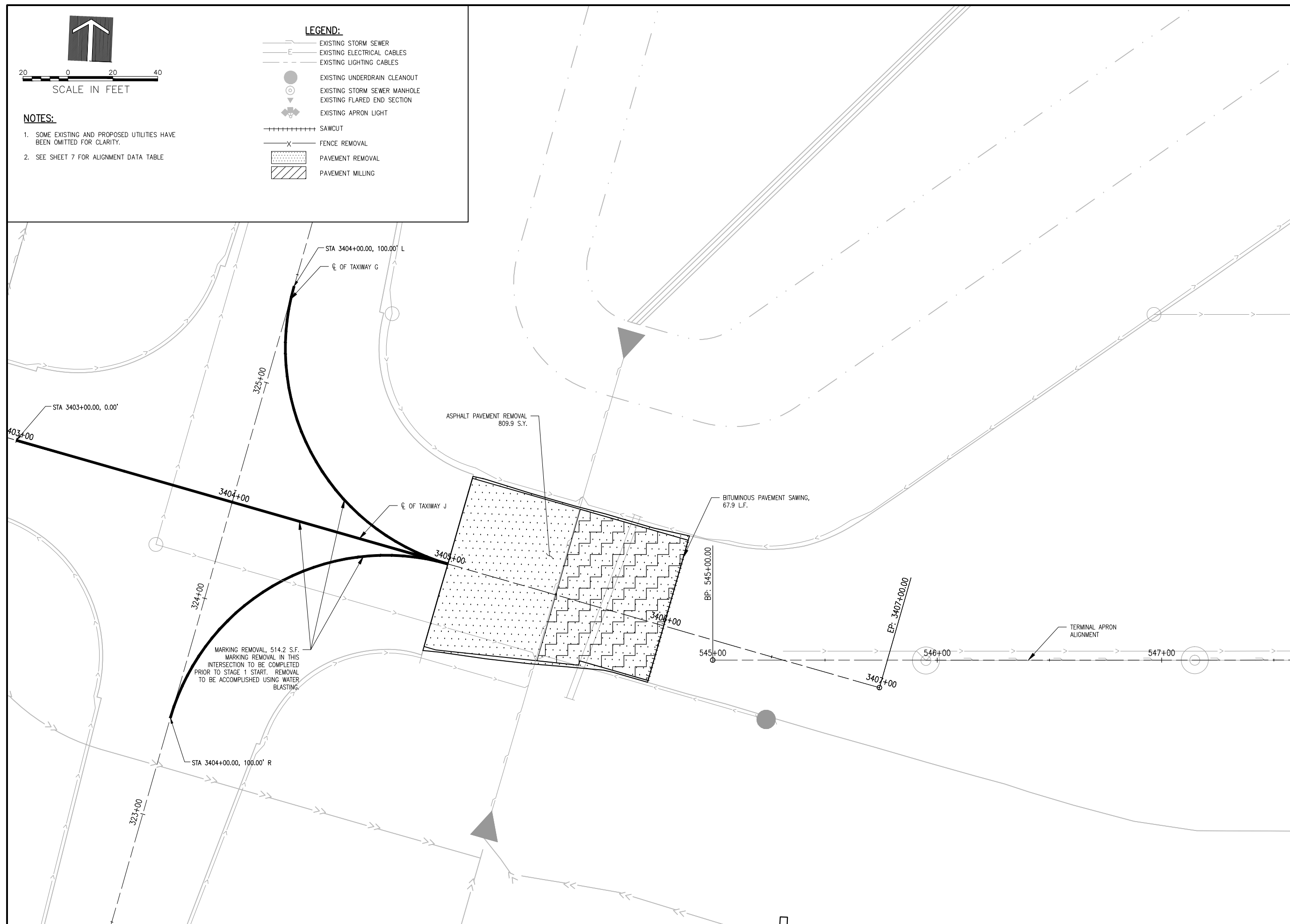

OCT 23, 2014, 8:37 AM HAUSM0682
I:\13A0089\08\401\3A0089\DESIGN\DRAWINGS\SHEETS\10-REMOVAL PLAN.DWG

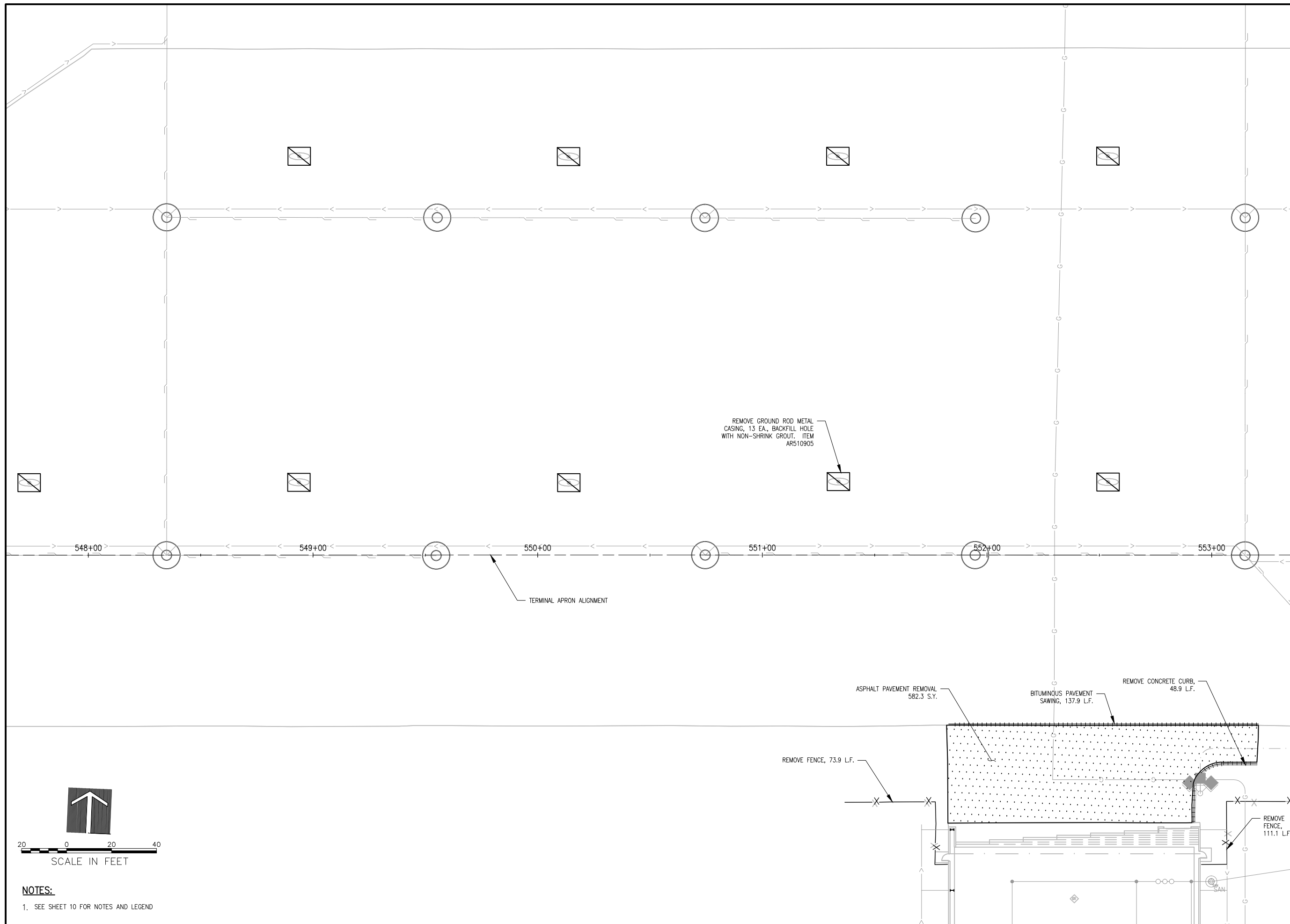

AIRCRAFT PARKING APRON REHABILITATION

IDA No: LOT-4298
SBG No: 3-17-SBGP-117
LE047

NO.	DATE	DESCRIPTION		
		LAY	DWN	REV

ISSUE: November 14, 2014
PROJECT NO: 13A0089
CAD FILE: 11-REMOVAL PLAN.DWG
LAYOUT BY: KMS 3/10/14
DRAWN BY: KMS 3/10/14
REVIEWED BY: RMH 11/14/14
© Copyright Hanson Professional Services Inc. 2011
SHEET TITLE

REMOVAL PLAN

OCT 23, 2014 8:37 AM HAUSM06682 \\113\DRS\008401\3A0089\DESIGN\DRAWINGS\SHEETS\11-REMOVAL PLAN.DWG

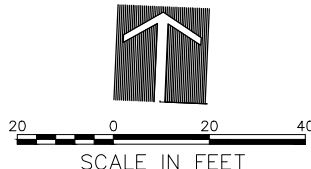

NOTES:
1. SEE SHEET 10 FOR NOTES AND LEGEND

**AIRCRAFT PARKING
APRON
REHABILITATION**

IDA No: LOT-4298
SBG No: 3-17-SBGP-117
LE047

NO.	DATE	DESCRIPTION		
		LAY	DWN	REV

ISSUE: November 14, 2014
PROJECT NO: 13A0089
CAD FILE: 12-REMOVAL PLAN.DWG
LAYOUT BY: KMS 3/10/14
DRAWN BY: KMS 3/10/14
REVIEWED BY: RMH 11/14/14
© Copyright Hanson Professional Services Inc. 2011
SHEET TITLE

REMOVAL PLAN

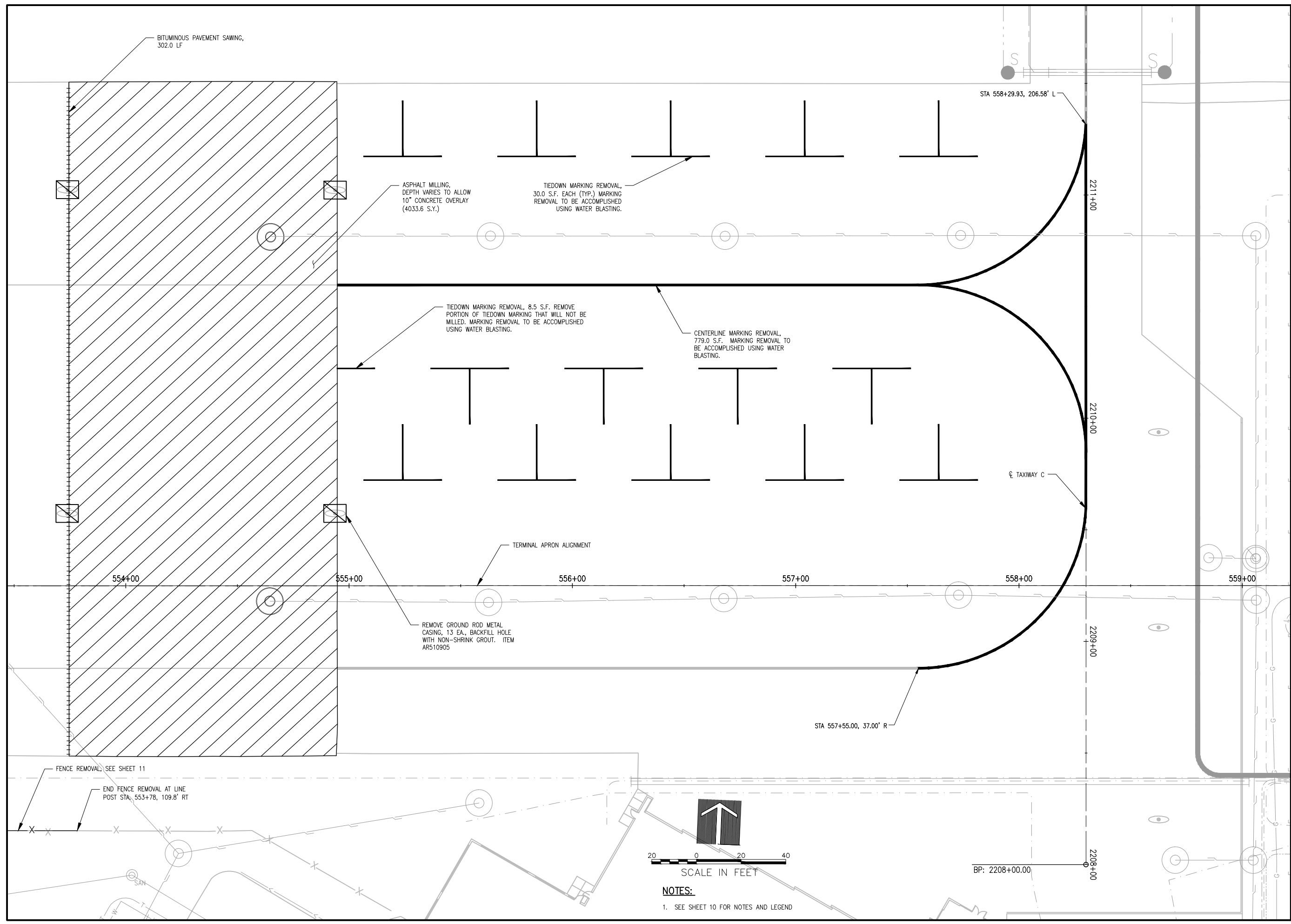

OCT 23, 2014, 8:37 AM HAUSM0682
I:\13\085\008401\3A0089\DESIGN\DRAWINGS\SHEETS\12-REMOVAL PLAN.DWG

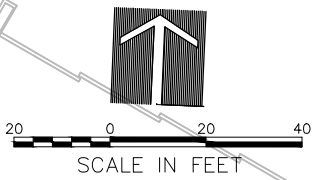

NOTES:
1. SEE SHEET 10 FOR NOTES AND LEGEND

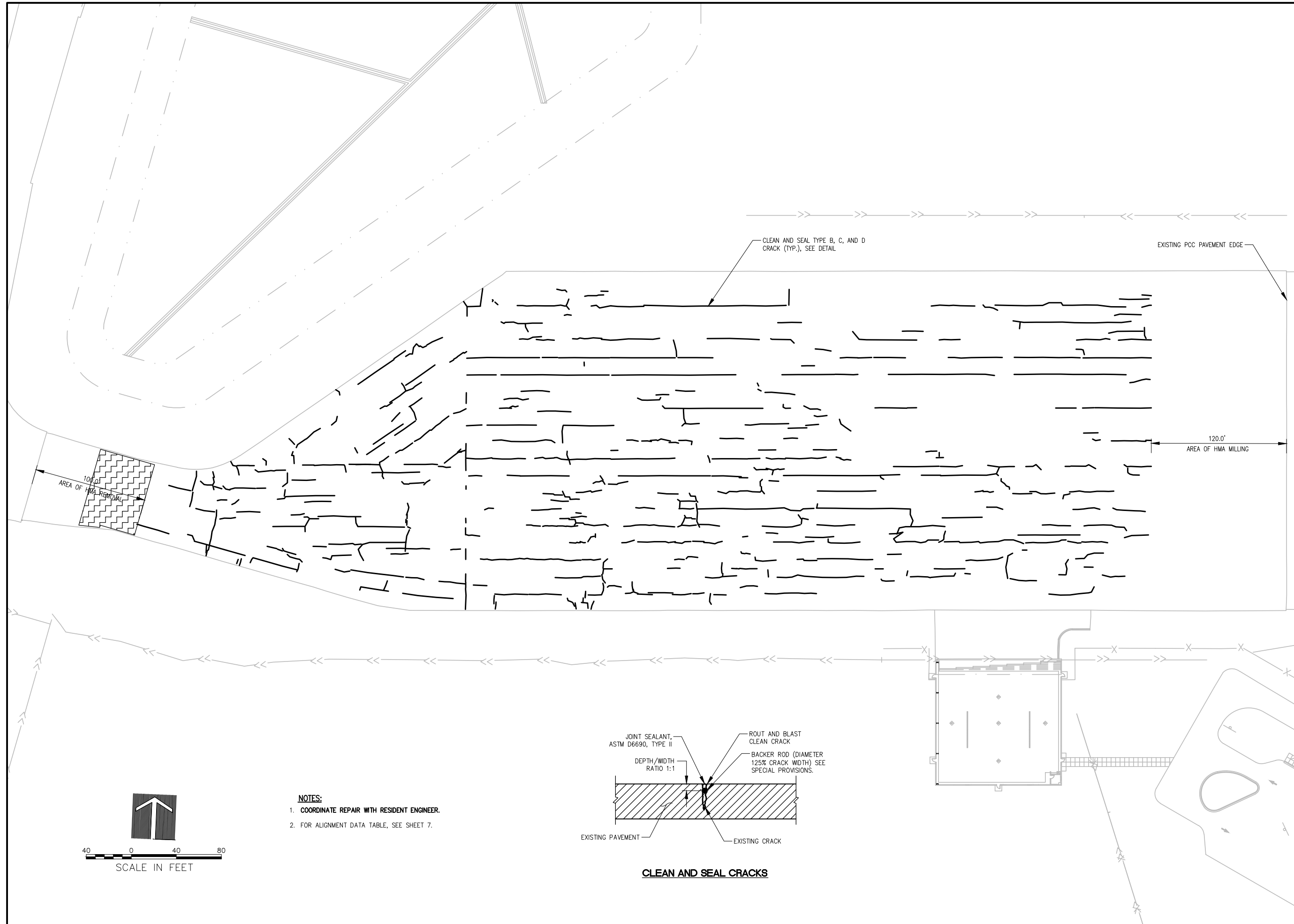

CLEAN AND SEAL TYPE B, C, AND D
CRACK (TYP.), SEE DETAIL

EXISTING PCC PAVEMENT EDGE

120.0'

AREA OF HMA MILLING

100'

AREA OF HMA REMOVAL

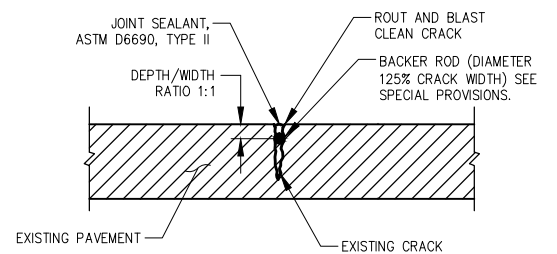

CLEAN AND SEAL CRACKS

- NOTES:**
- COORDINATE REPAIR WITH RESIDENT ENGINEER.
 - FOR ALIGNMENT DATA TABLE, SEE SHEET 7.

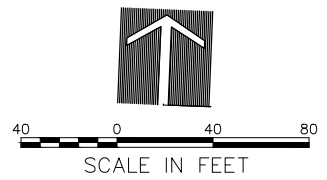

AIRCRAFT PARKING APRON REHABILITATION

IDA No: LOT-4298
SBG No: 3-17-SBGP-117
LE047

NO.	DATE	DESCRIPTION		
		LAY	DWN	REV

ISSUE: November 14, 2014
PROJECT NO: 13A0089
CAD FILE: 13-CRACKPLAN.DWG
LAYOUT BY: LDH 8/20/13
DRAWN BY: LDH 8/20/13
REVIEWED BY: RMH 11/14/14
© Copyright Hanson Professional Services Inc. 2011
SHEET TITLE

CRACK REPAIR PLAN AND DETAILS

OCT 23, 2014 8:38 AM HAUSM0682
I:\13\089\0084013A0089\DESIGN\DRAWINGS\SHEETS\13-CRACKPLAN.DWG

LEGEND:

- EXISTING STORM SEWER
- EXISTING ELECTRICAL CABLES
- EXISTING LIGHTING CABLES
- EXISTING BASE MOUNTED LIGHT
- EXISTING STAKE MOUNTED LIGHT
- ADJUST EXISTING STAKE MOUNTED LIGHT
- EXISTING STORM SEWER MANHOLE
- EXISTING FLARED END SECTION
- EXISTING INSPECTION HOLE
- EXISTING CLEAN OUT
- ADJUST EXISTING UNDERDRAIN STRUCTURE
- DRAINAGE SWALE
- PCC OVERLAY
- FULL DEPTH PAVEMENT

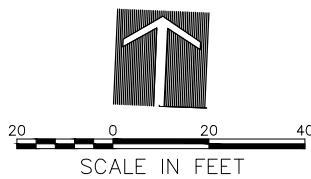

NOTES:

1. SOME UTILITIES HAVE BEEN OMITTED FOR CLARITY.
2. ALL NEW CONNECTIONS OF EXISTING UNDERDRAIN TO ADJUSTED STRUCTURES SHALL BE FURNISHED AS SPECIFIED AND COST INCIDENTAL TO UNDERDRAIN STRUCTURE ADJUSTMENT.

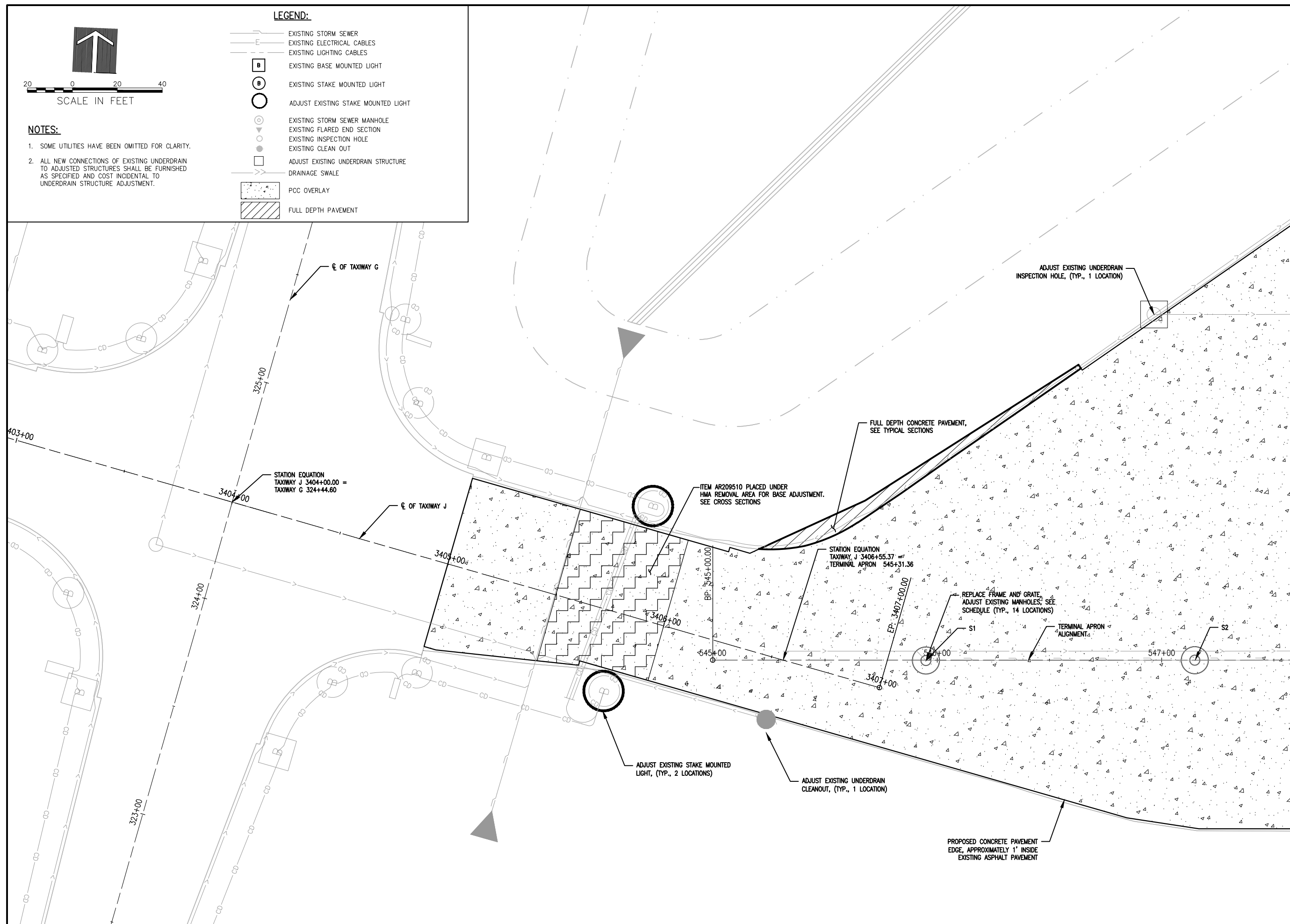

AIRCRAFT PARKING APRON REHABILITATION

IDA No: LOT-4298
SBG No: 3-17-SBGP-117
LE047

NO.	DATE	DESCRIPTION		
		LAY	DWN	REV

ISSUE: November 14, 2014
PROJECT NO: 13A0089
CAD FILE: 14-PROP PLAN.DWG
LAYOUT BY: KMS 3/10/14
DRAWN BY: KMS 3/10/14
REVIEWED BY: RMH 11/14/14
© Copyright Hanson Professional Services Inc. 2011
SHEET TITLE

PROPOSED PLAN

OCT 23, 2014, 8:38 AM HAUSM0682
I:\13A0089\008401\3A0089\DESIGN\DRAWINGS\SHEETS\14-PROP PLAN.DWG

**AIRCRAFT PARKING
APRON
REHABILITATION**

IDA No: LOT-4298
SBG No: 3-17-SBGP-117
LE047

NO.	DATE	DESCRIPTION		
		LAY	DWN	REV

ISSUE: November 14, 2014
PROJECT NO: 13A0089
CAD FILE: 15-PROP PLAN.DWG
LAYOUT BY: KMS 3/10/14
DRAWN BY: KMS 3/10/14
REVIEWED BY: RMH 11/14/14
© Copyright Hanson Professional Services Inc. 2011
SHEET TITLE

PROPOSED PLAN

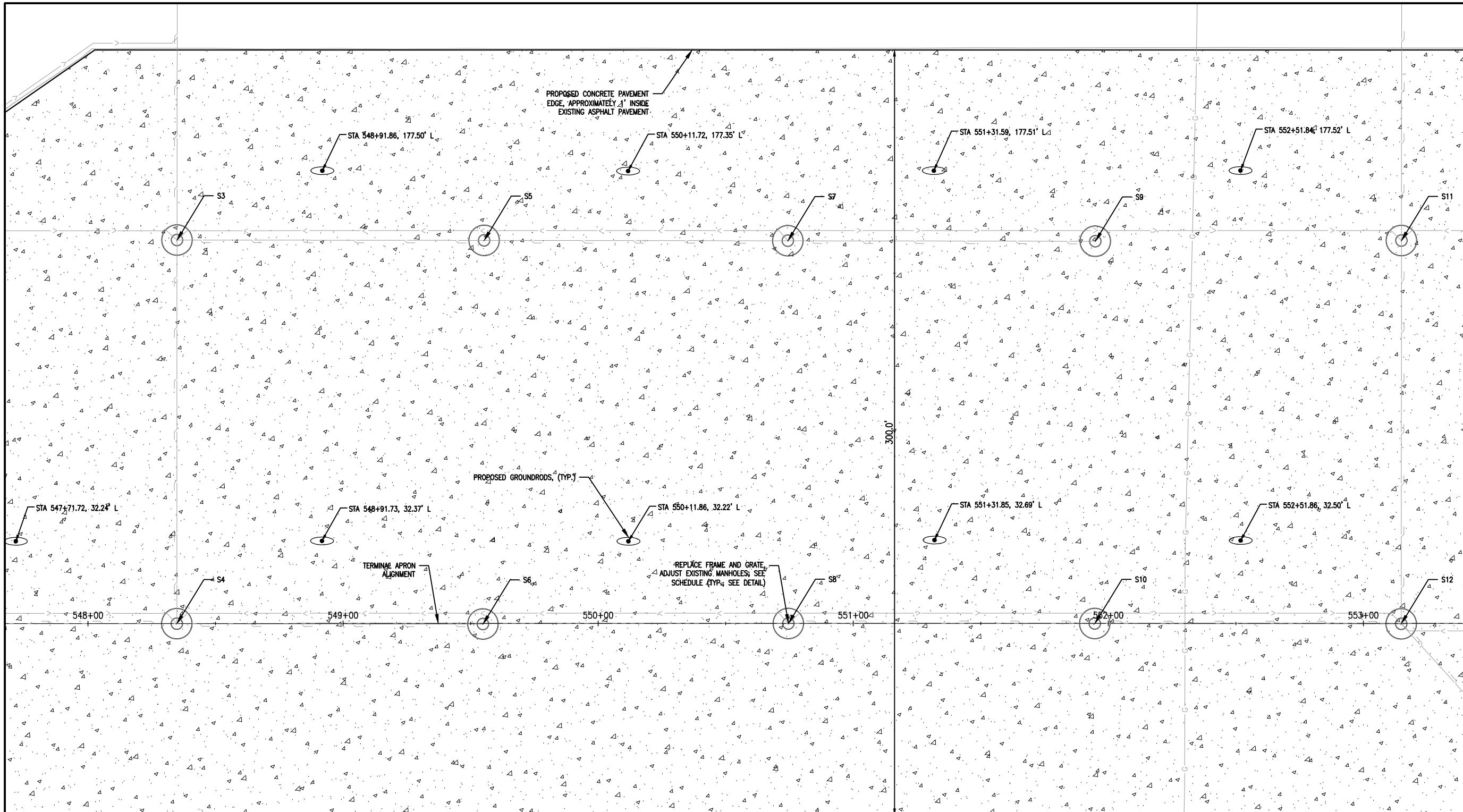

BOLLARD LOCATION TABLE

	STATION	OFFSET	
1	552+93.18	103.11	R
2	552+96.68	103.11	R
3	552+98.43	106.15	R
4	552+96.68	109.18	R
5	552+93.18	109.18	R
6	552+91.43	106.15	R

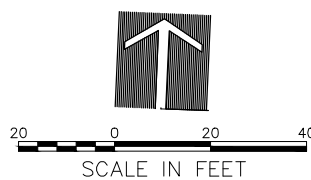
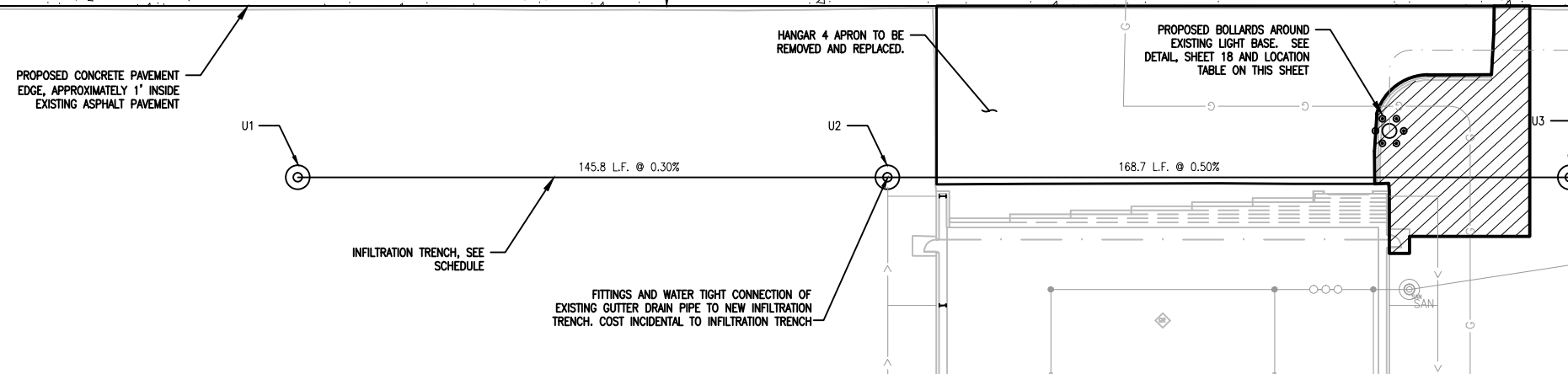

NOTES:
1. SEE SHEET 14 FOR NOTES AND LEGEND

OCT 23, 2014, 8:38 AM HAUSM06682
I:\13\08\1008\4013A\089\DESIGN\DRAWINGS\SHEETS\15-PROP PLAN.DWG

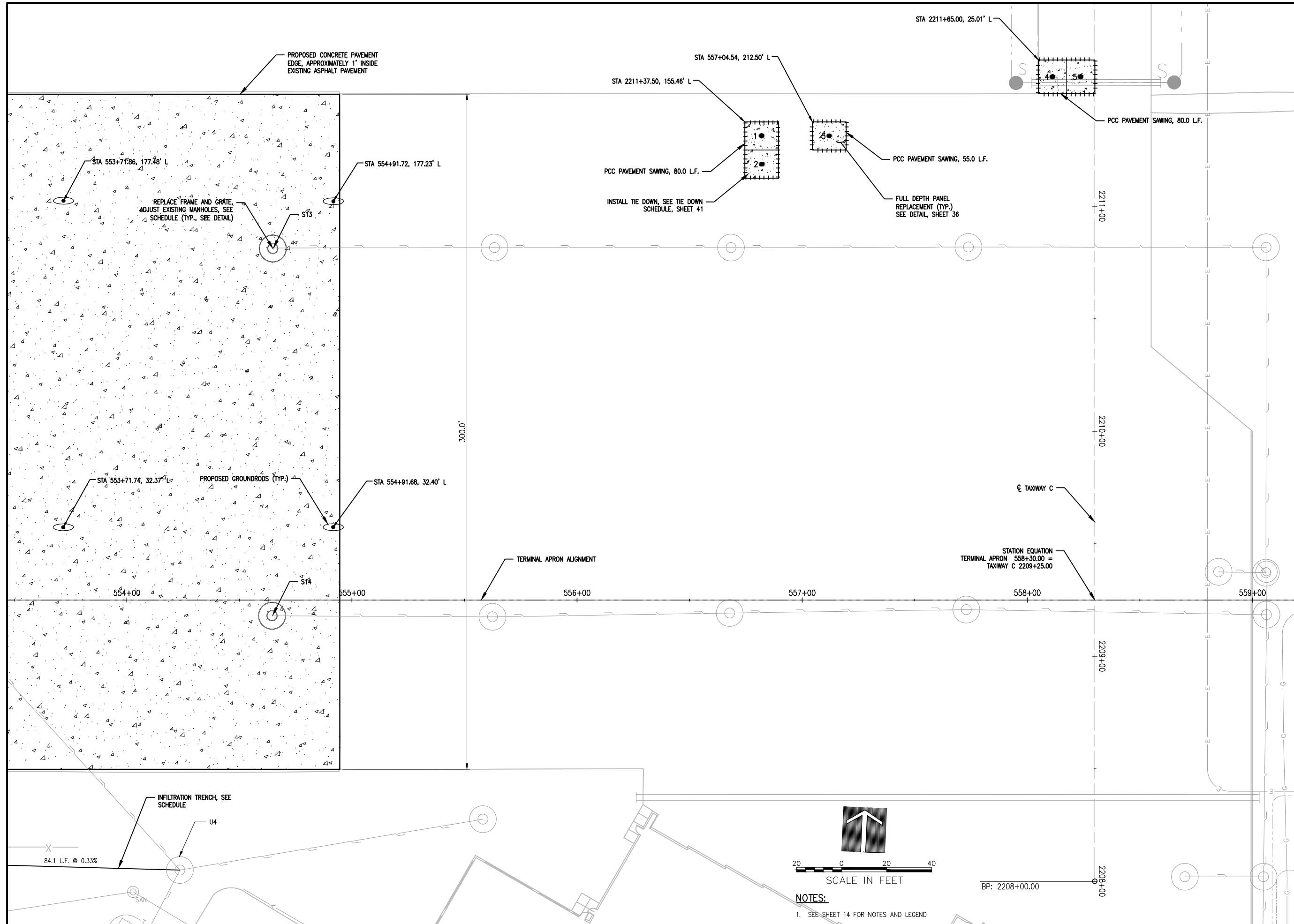

**AIRCRAFT PARKING
APRON
REHABILITATION**

IDA No: LOT-4298
SBG No: 3-17-SBGP-117
LE047

NO.	DATE	DESCRIPTION		
		LAY	DWN	REV

ISSUE: November 14, 2014
PROJECT NO: 13A0089
CAD FILE: 16-PROP PLAN.DWG
LAYOUT BY: KMS 3/10/14
DRAWN BY: KMS 3/10/14
REVIEWED BY: RMH 11/14/14
© Copyright Hanson Professional Services Inc. 2011
SHEET TITLE

PROPOSED PLAN

OCT 23, 2014 8:38 AM HAUSM06682
I:\13\089\008401\3A0089\DESIGN\DRAWINGS\SHEETS\16-PROP PLAN.DWG

NOTES:
1. SEE SHEET 14 FOR NOTES AND LEGEND

NO.	DATE	DESCRIPTION		
		LAY	DWN	REV

ISSUE: November 14, 2014
PROJECT NO: 13A0089
CAD FILE: 17-DRAINAGEDET.DWG
LAYOUT BY: KMS 3/17/14
DRAWN BY: KMS 3/17/14
REVIEWED BY: RMH 11/14/14
© Copyright Hanson Professional Services Inc. 2011
SHEET TITLE

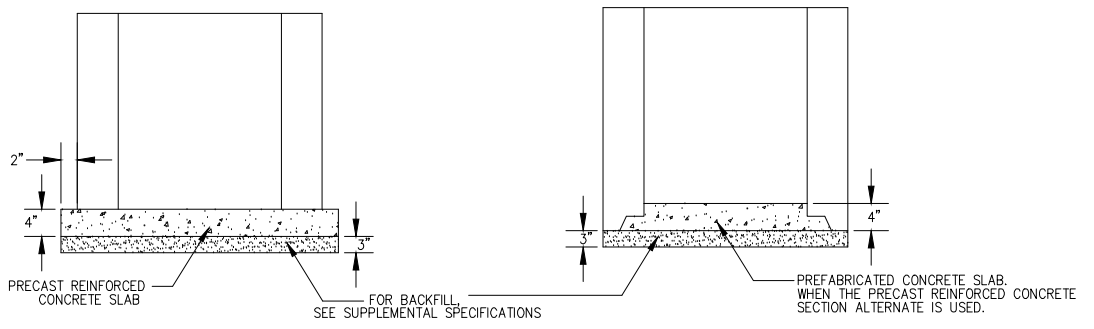
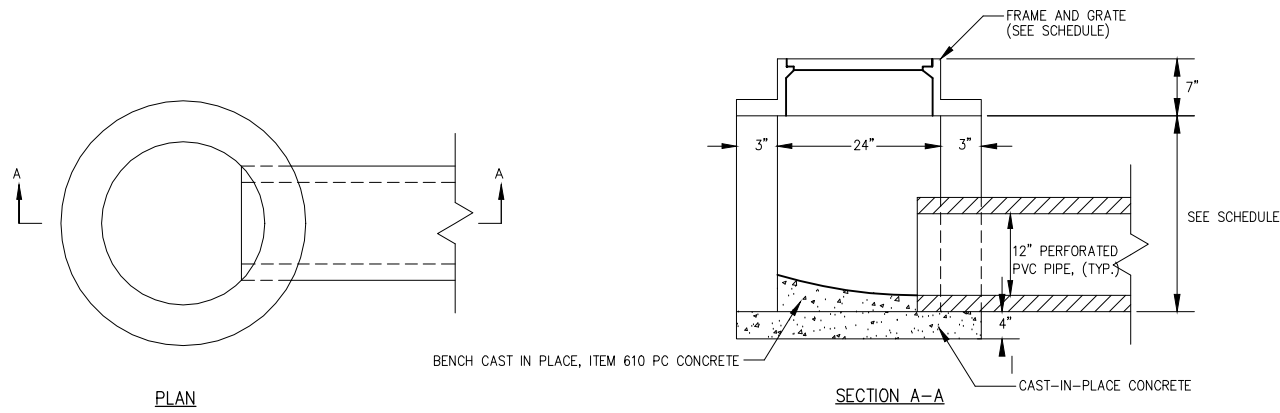

ALTERNATE METHODS

NOTE
1. SEE DRAINAGE PLANS AND INFILTRATION TRENCH SCHEDULE FOR LOCATION, SIZE AND NUMBER OF PIPE CONNECTIONS.

INLET TYPE A
(IDOT STANDARD 602301)

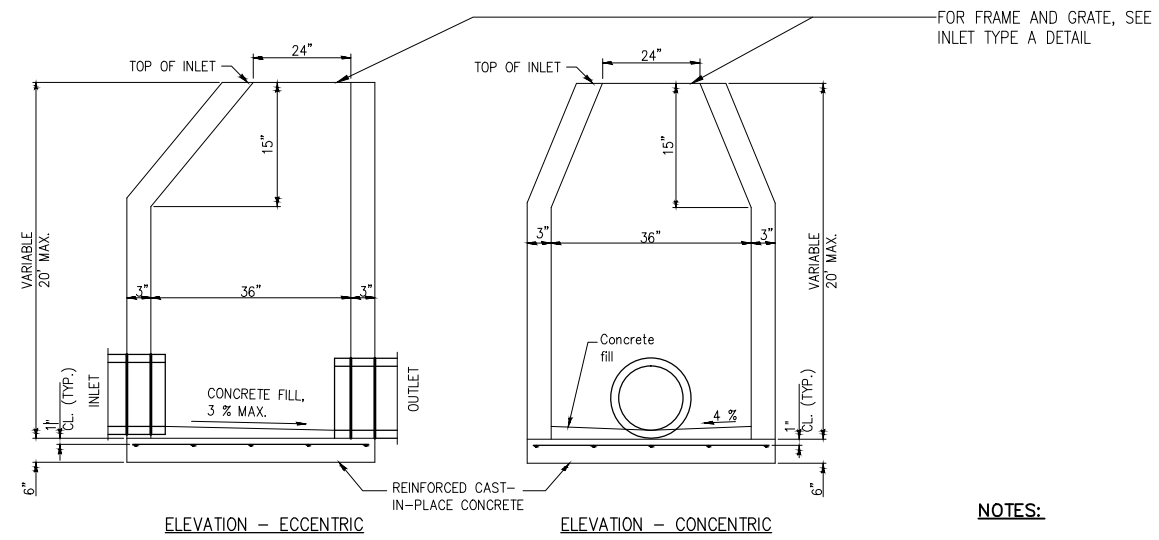

NOTES:

- BOTTOM SLABS SHALL BE REINFORCED WITH A MINIMUM OF 0.20 SQ. IN./FT. IN BOTH DIRECTION WITH A MAXIMUM SPACING OF 12".
- BOTTOM SLABS MAY BE CONNECTED TO THE RISER AS DETERMINED BY THE FABRICATOR; HOWEVER, ONLY A SINGLE ROW OF REINFORCEMENT AROUND THE PERIMETER MAY BE UTILIZED.
- SEE STANDARD 602601 FOR OPTIONAL PRECAST REINFORCED CONCRETE FLAT SLAB TOP

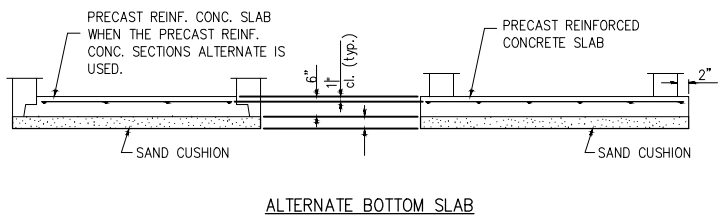

ALTERNATE BOTTOM SLAB

INLET TYPE B
(IDOT STANDARD 602306)

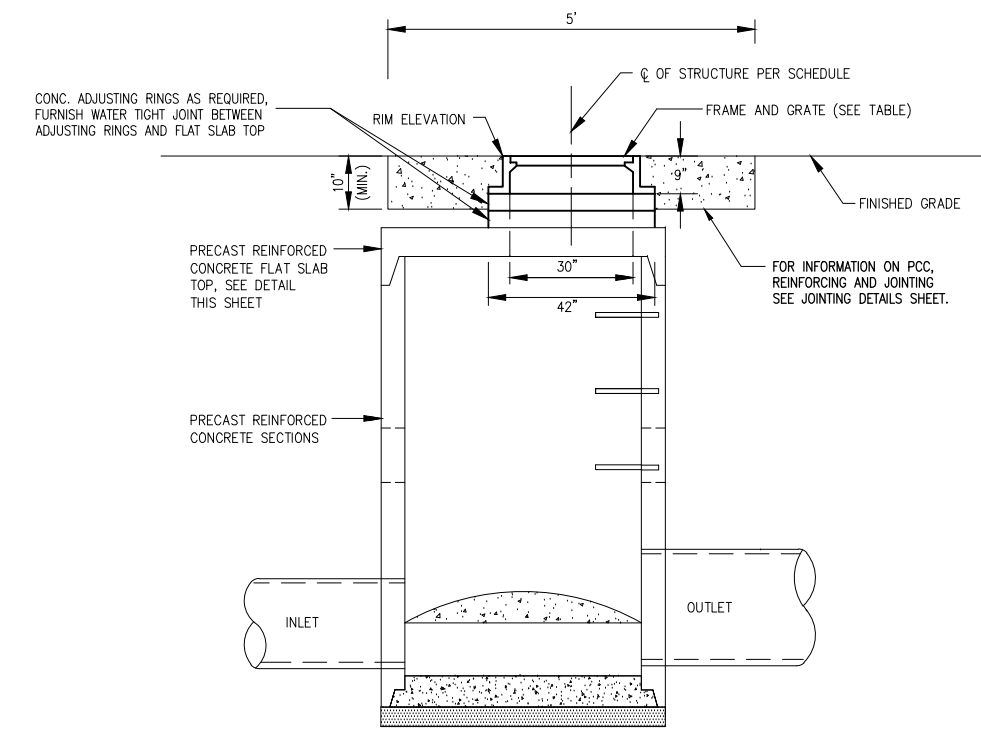

EXISTING MANHOLE ADJUSTMENT

MANHOLE ADJUSTMENT SCHEDULE

Structure	Grate Type	Station	Offset		Rim Elevation
S1	Neenah R-3492-A1	545+95.00	0.2'	RT	667.89
S2	Neenah R-3492-A1	547+14.80	0.1'	RT	667.67
S3	Neenah R-3492-A1	548+34.91	150.3'	LT	667.67
S4	Neenah R-3492-A1	548+34.83	0.1'	RT	667.67
S5	Neenah R-3492-A1	549+55.32	150.2'	LT	667.67
S6	Neenah R-3492-A1	549+54.87	0.3'	RT	667.67
S7	Neenah R-3492-A1	550+74.43	150.0'	LT	667.67
S8	Neenah R-3492-A1	550+74.58	0.0'	RT	667.67
S9	Neenah R-3492-A1	551+94.95	149.8'	LT	667.67
S10	Neenah R-3492-A1	551+94.70	0.1'	RT	667.67
S11	Neenah R-3492-A1	553+14.93	150.1'	LT	667.67
S12	Neenah R-3492-A1	553+14.83	0.2'	RT	667.67
S13	Neenah R-3492-A1	554+64.90	156.3'	LT	667.37
S14	Neenah R-3492-A1	554+64.55	7.0'	RT	667.38

INFILTRATION TRENCH SCHEDULE

Structure	Type	Grate Type	Station	Offset	Rim Elevation	Invert Elevation
U1	Inlet Type A	Neenah R-2390 Type C	550+25.00	117.6'	RT 666.18	E - 663.68
U2	Inlet Type B	Neenah R-2390 Type C	551+70.80	117.6'	RT 667.10	W - 663.24 E - 663.14
U3	Inlet Type B	Neenah R-2390 Type C	553+39.50	117.6'	RT 666.41	W - 662.30 E - 662.20
---	Existing MH	---	554+23.58	120.0'	RT ---	W - 661.92

OCT 23, 2014 8:38 AM HAUSM0682 P:\2010\06\01\3A0089\DESIGN\DRAWINGS\SHEETS\17-DRAINAGEDET.DWG

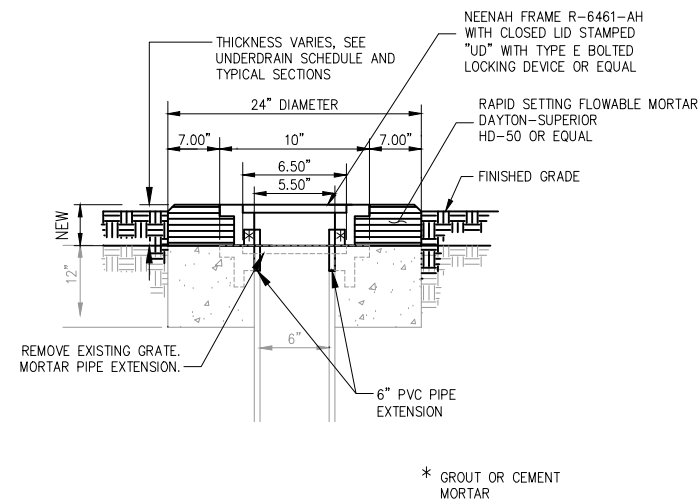

**PROPOSED UNDERDRAIN
STRUCTURE ADJUSTMENT**

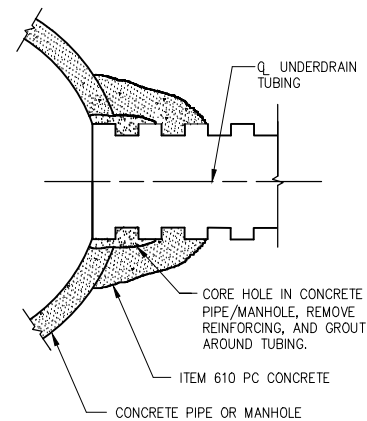

**STORM SEWER CONCRETE COLLAR
AND GROUT CONNECTION**

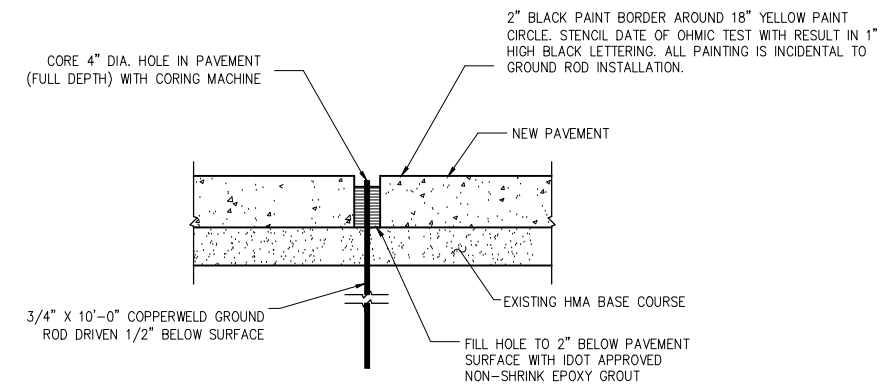

**IN PAVEMENT
GROUND ROD DETAIL**

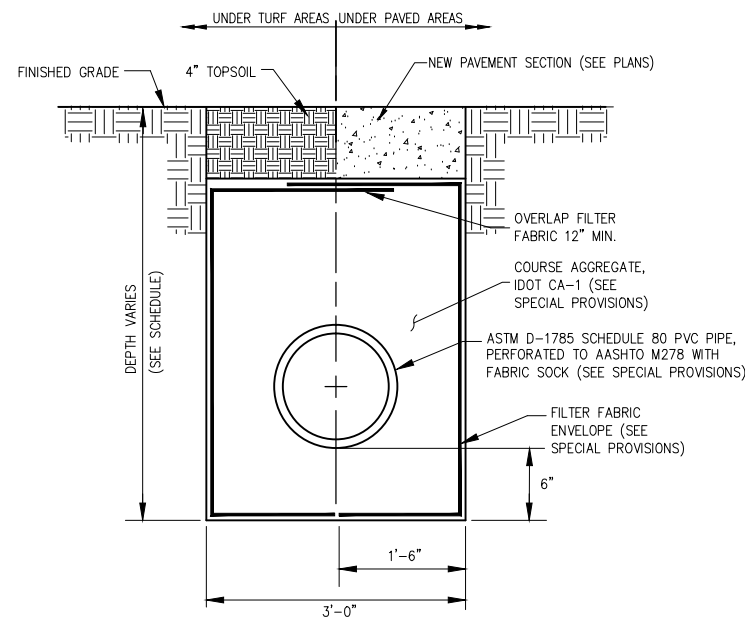

NOTES

1. UNSUITABLE MATERIAL ENCOUNTERED DURING PLACEMENT OF BEDDING SHALL BE REMOVED AND REPLACED.
2. COARSE AGGREGATE SHALL CONSIST OF IDOT GRADATION CA-1.
3. DO NOT COMPACT SOIL PLACED ABOVE THE COARSE AGGREGATE.
4. SEPARATE PAYMENT FOR COARSE AGGREGATE, FILTER FABRIC ENVELOPE, PVC PIPE, AND FABRIC SOCK WILL NOT BE MADE BUT SHALL BE INCLUDED IN THE CONTRACT UNIT PRICE PER LINEAR FOOT OF INFILTRATION TRENCH.

INFILTRATION TRENCH

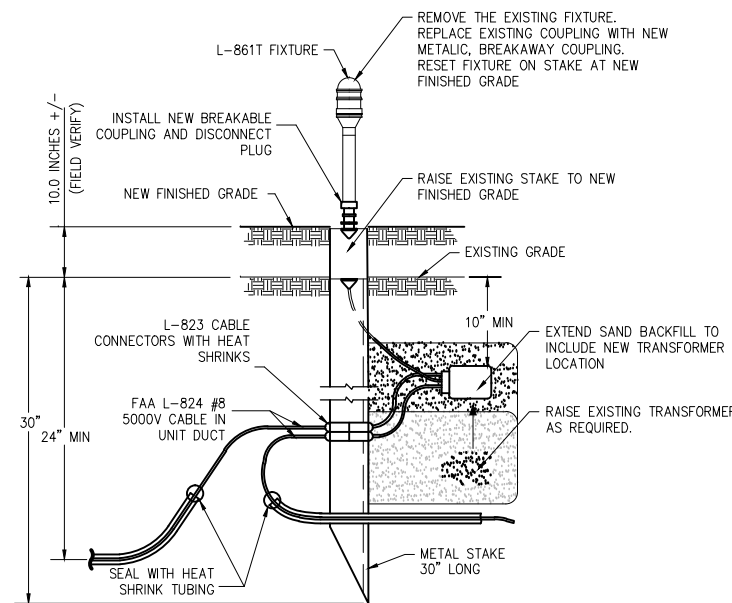

1. BREAKABLE COUPLING SHALL NOT BE OVER 1" ABOVE STAKE.
2. CONTRACTOR SHALL EXPOSE AND REROUTE PRIMARY CABLE AND/OR ADD CABLE EXTENSIONS IN A MANNER ACCEPTABLE TO RESIDENT ENGINEER SO THAT AT LEAST 1 FOOT OF SLACK IS PROVIDED ON EACH END OF CABLE.
3. SEE SPECIAL PROVISIONS FOR ADDITIONAL REQUIREMENTS.
4. ALL MATERIALS REQUIRED TO FURNISH A COMPLETE, OPERATING FIXTURE SHALL BE PAID UNDER ITEM AR125941.

STAKE MOUNTED LIGHT ADJUSTMENT

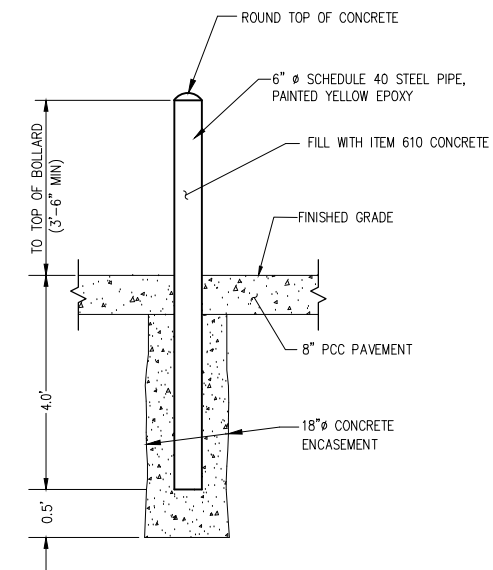

NOTES

1. THE EXPOSED PORTION OF THE BOLLARD SHALL BE PAINTED YELLOW EPOXY.
2. BOLLARD AND ASSOCIATED ITEMS ARE INCIDENTAL TO THE ELECTRIC SLIDING GATE.

BOLLARD DETAIL

**AIRCRAFT PARKING
APRON
REHABILITATION**

IDA No: LOT-4298
SBG No: 3-17-SBGP-117
LE047

NO.	DATE	DESCRIPTION		
		LAY	DWN	REV

ISSUE: November 14, 2014
PROJECT NO: 13A0089
CAD FILE: 18-MISCDET.DWG
LAYOUT BY: KMS 3/17/14
DRAWN BY: KMS 3/17/14
REVIEWED BY: RMH 11/14/14
© Copyright Hanson Professional Services Inc. 2011
SHEET TITLE

**DRAINAGE AND
MISCELLANEOUS
DETAILS**

Earthwork Summary in Cubic Yards	
Cut	
Topsoil	630
Misc. (Clay, Sand, Aggregate)	0
Total Unclassified Cut	630
Backfill	
Structural Fill	780
Total Backfill	780
Topsoil Fill	
Topsoil from On Site	630
Total Topsoil Required	922
Offsite Topsoil Required	292

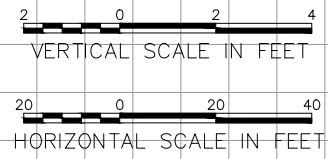

STA.
545+50

TOTAL CUT = 26.8 S.F.
TOTAL FILL = 70.0 S.F.

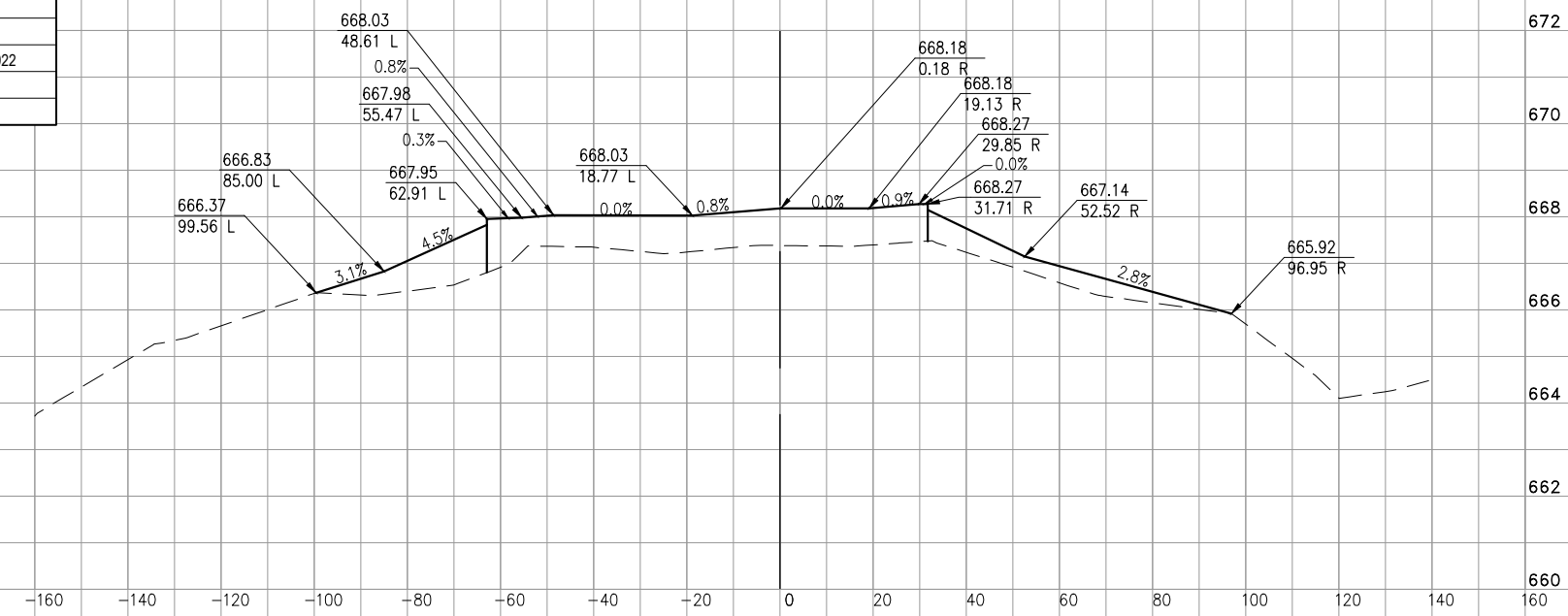

STA.
545+31

TOTAL CUT = 30.6 S.F.
TOTAL FILL = 76.7 S.F.

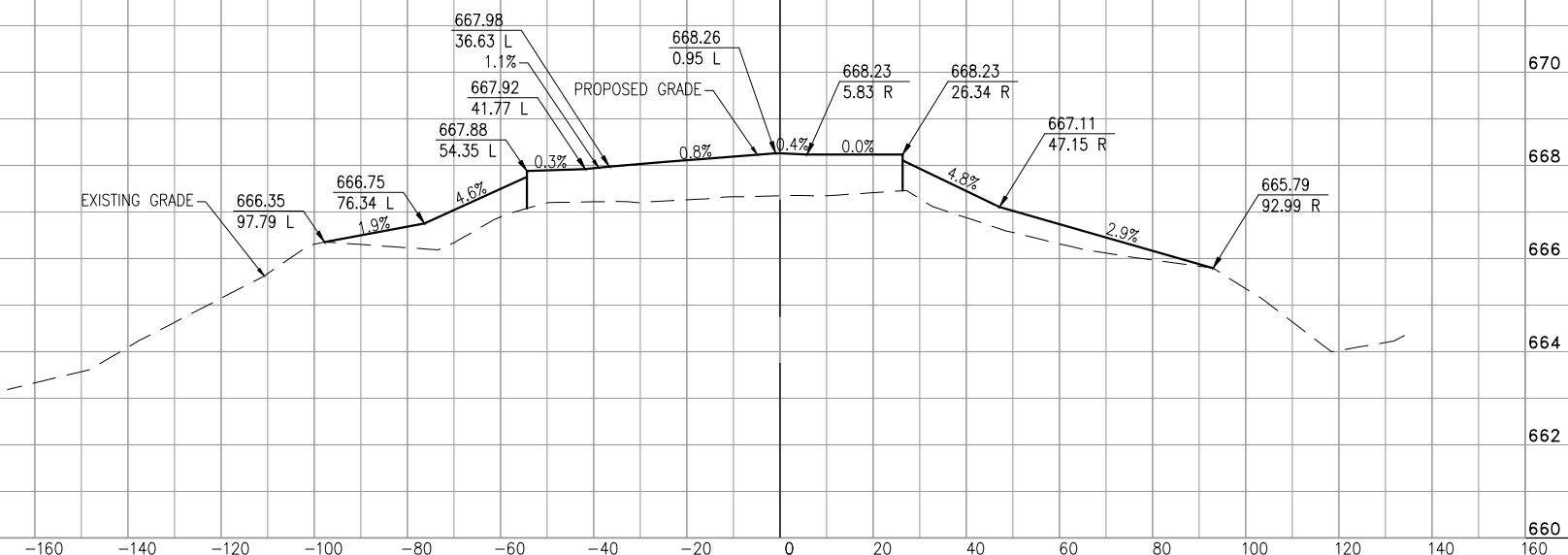

AIRCRAFT PARKING
APRON
REHABILITATION

IDA No: LOT-4298
SBG No: 3-17-SBGP-117
LE047

NO.	DATE	DESCRIPTION		
		LAY	DWN	REV

ISSUE: November 14, 2014
PROJECT NO: 13A0089
CAD FILE: 19-CROSS SECTIONS.DWG
LAYOUT BY: KMS 2/13/14
DRAWN BY: KMS 2/13/14
REVIEWED BY: RMH 11/14/14
© Copyright Hanson Professional Services Inc. 2011
SHEET TITLE

CROSS SECTIONS
APRON ALIGNMENT

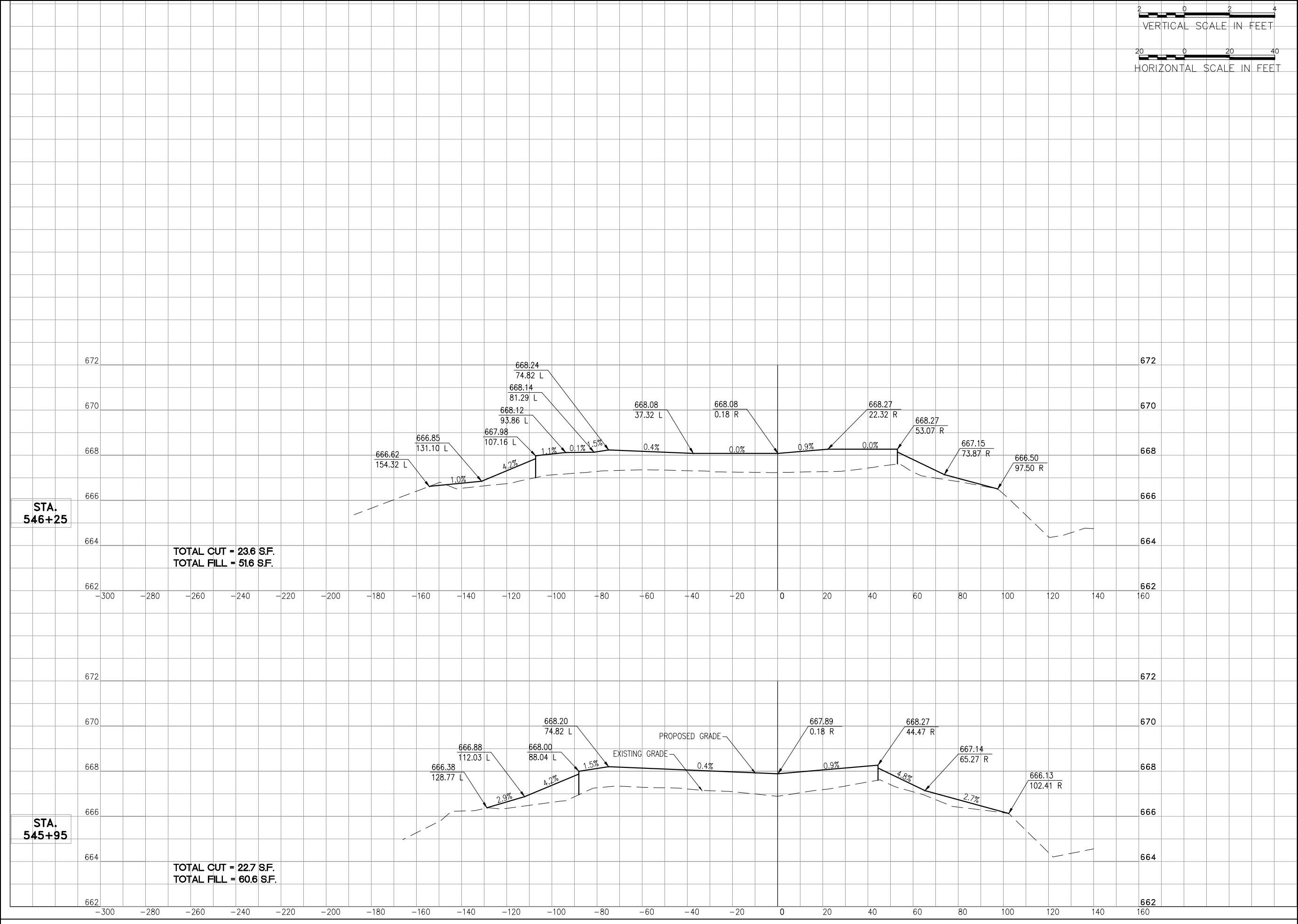
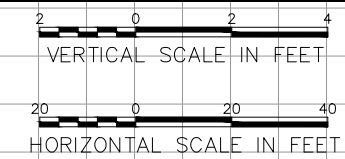

**AIRCRAFT PARKING
APRON
REHABILITATION**

IDA No: LOT-4298
SBG No: 3-17-SBGP-117
LE047

NO.	DATE	DESCRIPTION		
		LAY	DWN	REV

ISSUE: November 14, 2014
PROJECT NO: 13A0089
CAD FILE: 20-CROSS SECTIONS.DWG
LAYOUT BY: KMS 2/13/14
DRAWN BY: KMS 2/13/14
REVIEWED BY: RMH 11/14/14
© Copyright Hanson Professional Services Inc. 2011
SHEET TITLE

**CROSS SECTIONS
APRON ALIGNMENT**

OCT 23, 2014 8:39 AM HAUSM0682
I:\3\085\008401\3A\0089\DESIGN\DRAWINGS\SHEETS\20-CROSS SECTIONS.DWG

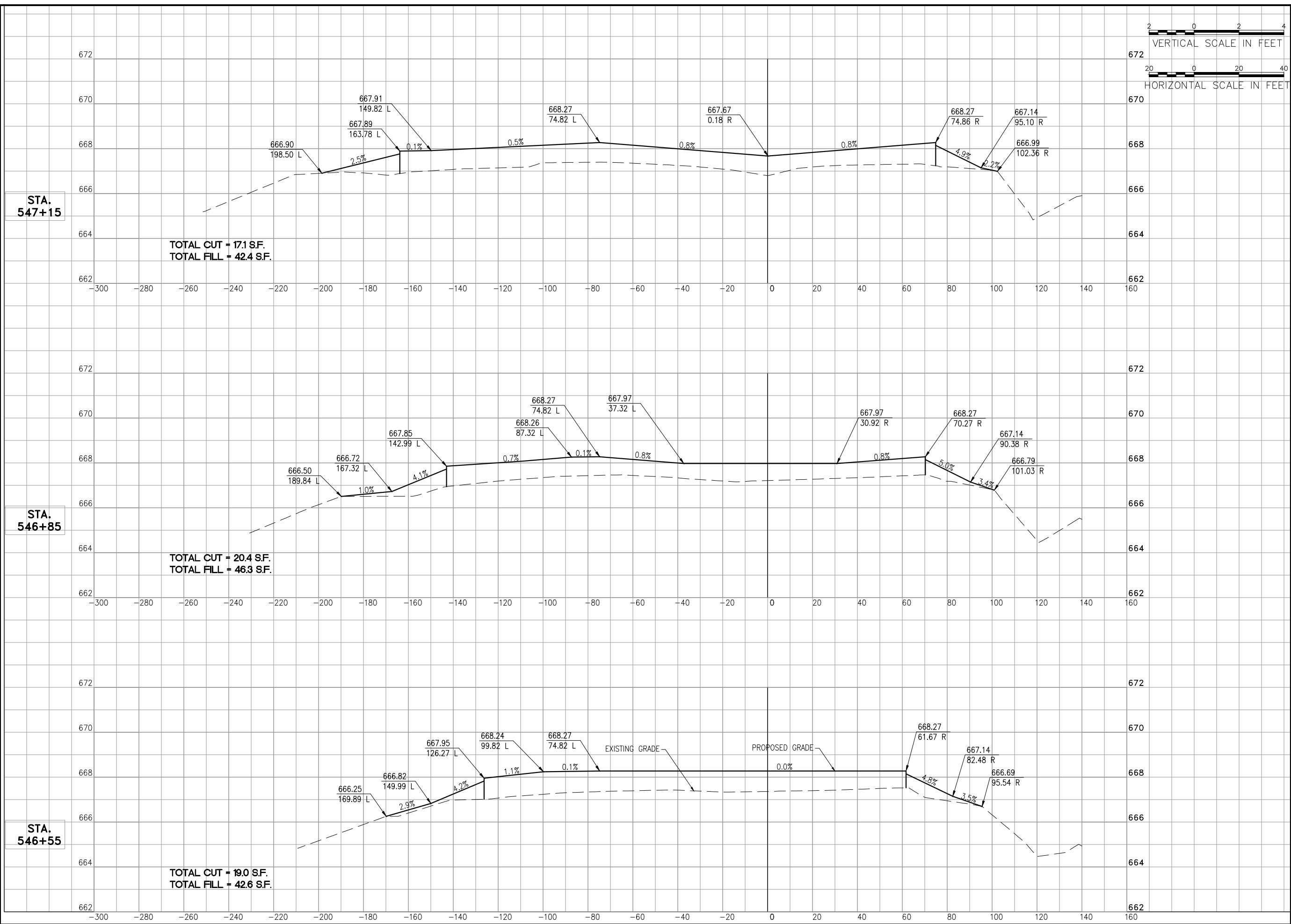
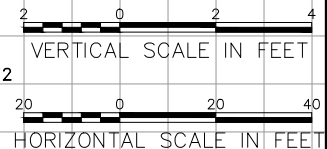

**AIRCRAFT PARKING
APRON
REHABILITATION**

IDA No: LOT-4298
SBG No: 3-17-SBGP-117
LE047

NO.	DATE	DESCRIPTION		
		LAY	DWN	REV

ISSUE: November 14, 2014
PROJECT NO: 13A0089
CAD FILE: 21-CROSS SECTIONS.DWG
LAYOUT BY: KMS 2/13/14
DRAWN BY: KMS 2/13/14
REVIEWED BY: RMH 11/14/14
© Copyright Hanson Professional Services Inc. 2011
SHEET TITLE

**CROSS SECTIONS
APRON ALIGNMENT**

OCT 23, 2014 8:39 AM HAUSM0682
I:\13A0089\08\401\3A0089\DESIGN\DRAWINGS\SHEETS\21-CROSS SECTIONS.DWG

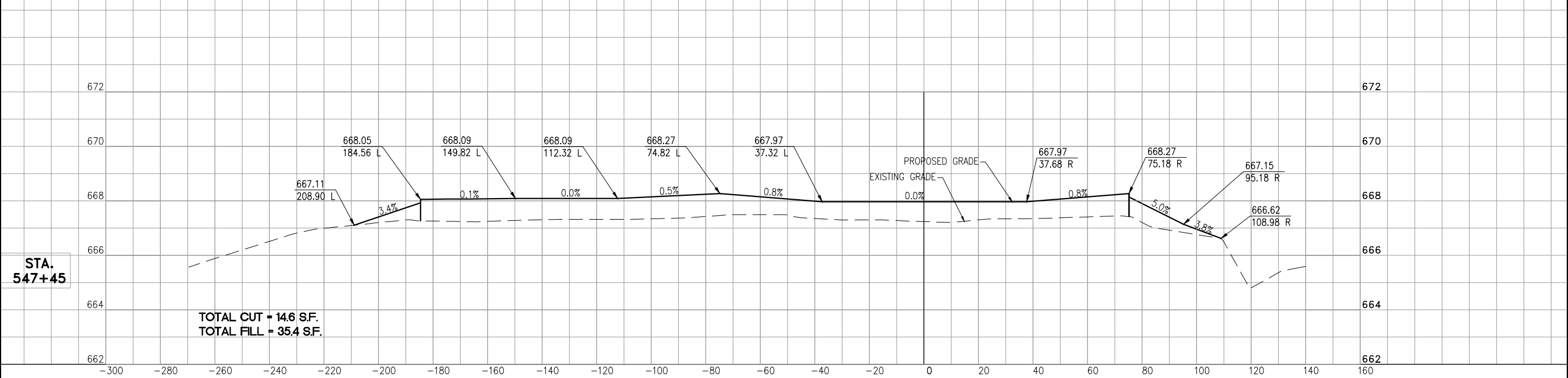
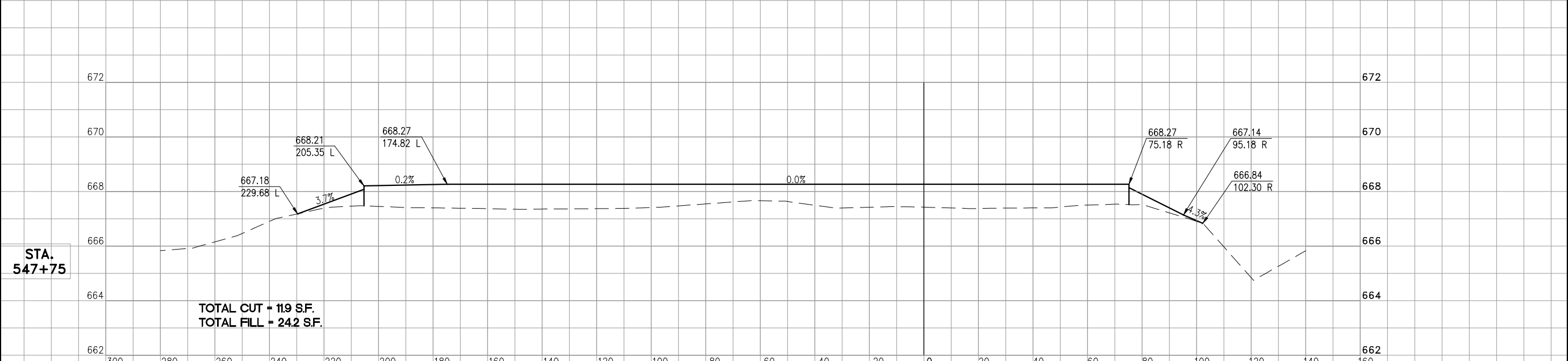
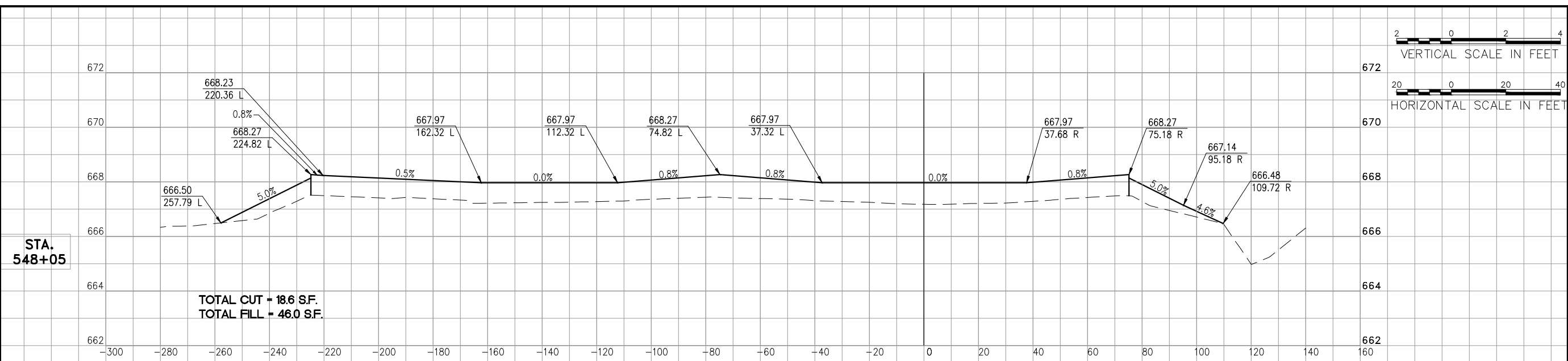
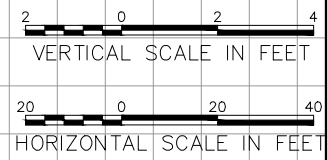

**AIRCRAFT PARKING
APRON
REHABILITATION**

IDA No: LOT-4298
SBG No: 3-17-SBGP-117
LE047

NO.	DATE	DESCRIPTION		
		LAY	DWN	REV

ISSUE: November 14, 2014
PROJECT NO: 13A0089
CAD FILE: 22-CROSS SECTIONS.DWG
LAYOUT BY: KMS 2/13/14
DRAWN BY: KMS 2/13/14
REVIEWED BY: RMH 11/14/14
© Copyright Hanson Professional Services Inc. 2011
SHEET TITLE

**CROSS SECTIONS
APRON ALIGNMENT**

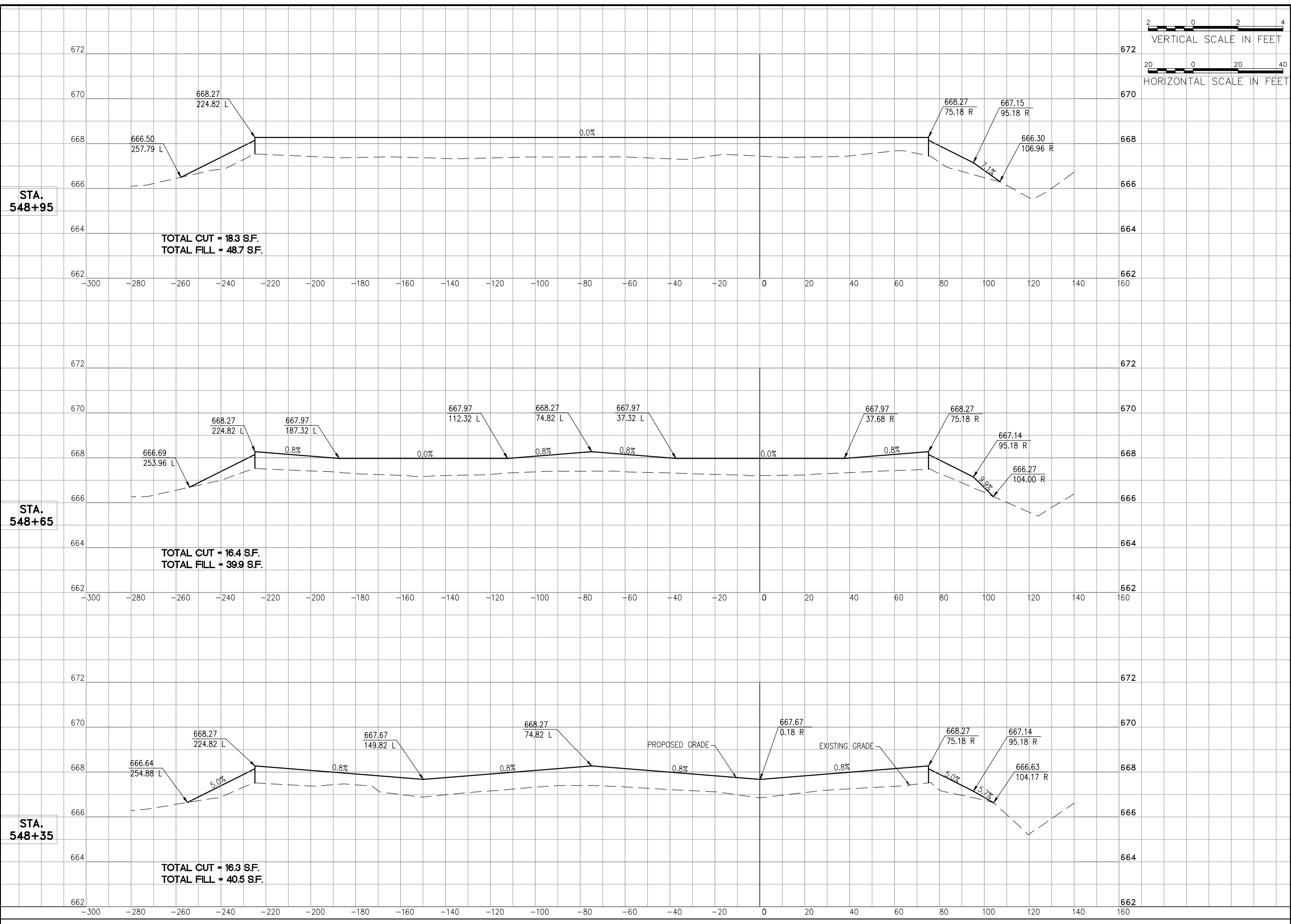
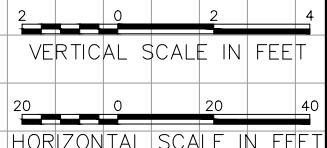

**AIRCRAFT PARKING
APRON
REHABILITATION**

IDA No: LOT-4298
SBG No: 3-17-SBGP-117
LE047

NO.	DATE	DESCRIPTION		
		LAY	DWN	REV

ISSUE: November 14, 2014
PROJECT NO: 13A0089
CAD FILE: 23-CROSS SECTIONS.DWG
LAYOUT BY: KMS 2/13/14
DRAWN BY: KMS 2/13/14
REVIEWED BY: RMH 11/14/14
© Copyright Hanson Professional Services Inc. 2011
SHEET TITLE

**CROSS SECTIONS
APRON ALIGNMENT**

OCT 23, 2014 8:40 AM HAUSM0682
I:\3\085\008401\3A0089\DESIGN\DRAWINGS\SHEETS\23-CROSS SECTIONS.DWG

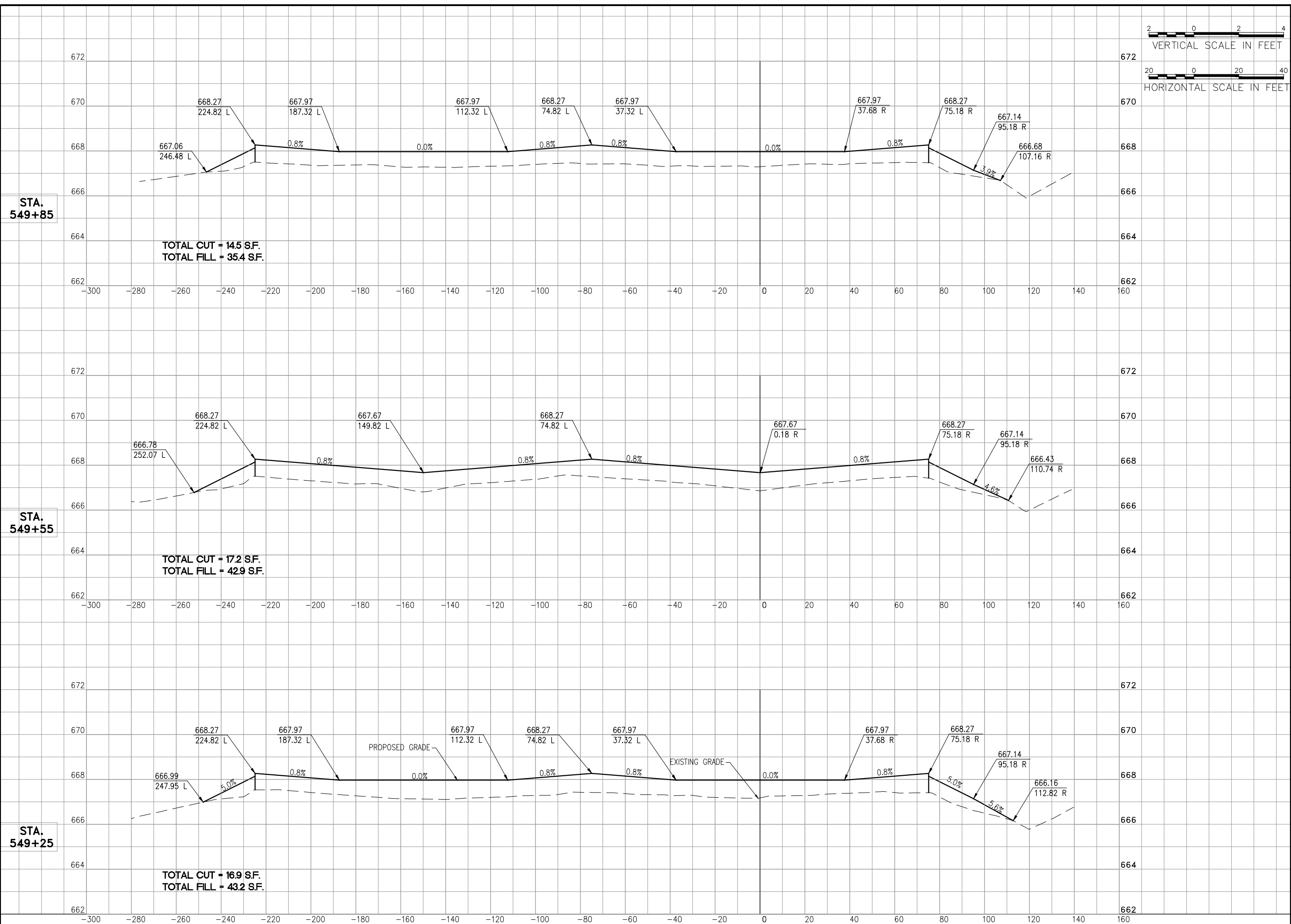
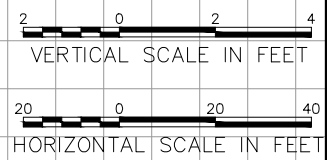

**AIRCRAFT PARKING
APRON
REHABILITATION**

IDA No: LOT-4298
SBG No: 3-17-SBGP-117
LE047

NO.	DATE	DESCRIPTION		
		LAY	DWN	REV

ISSUE: November 14, 2014
PROJECT NO: 13A0089
CAD FILE: 24-CROSS SECTIONS.DWG
LAYOUT BY: KMS 2/13/14
DRAWN BY: KMS 2/13/14
REVIEWED BY: RMH 11/14/14
© Copyright Hanson Professional Services Inc. 2011
SHEET TITLE

**CROSS SECTIONS
APRON ALIGNMENT**

OCT 23, 2014 8:40 AM HAUSM0682
I:\13\085\0084\013A\0089\DESIGN\DRAWINGS\SHEETS\24-CROSS SECTIONS.DWG

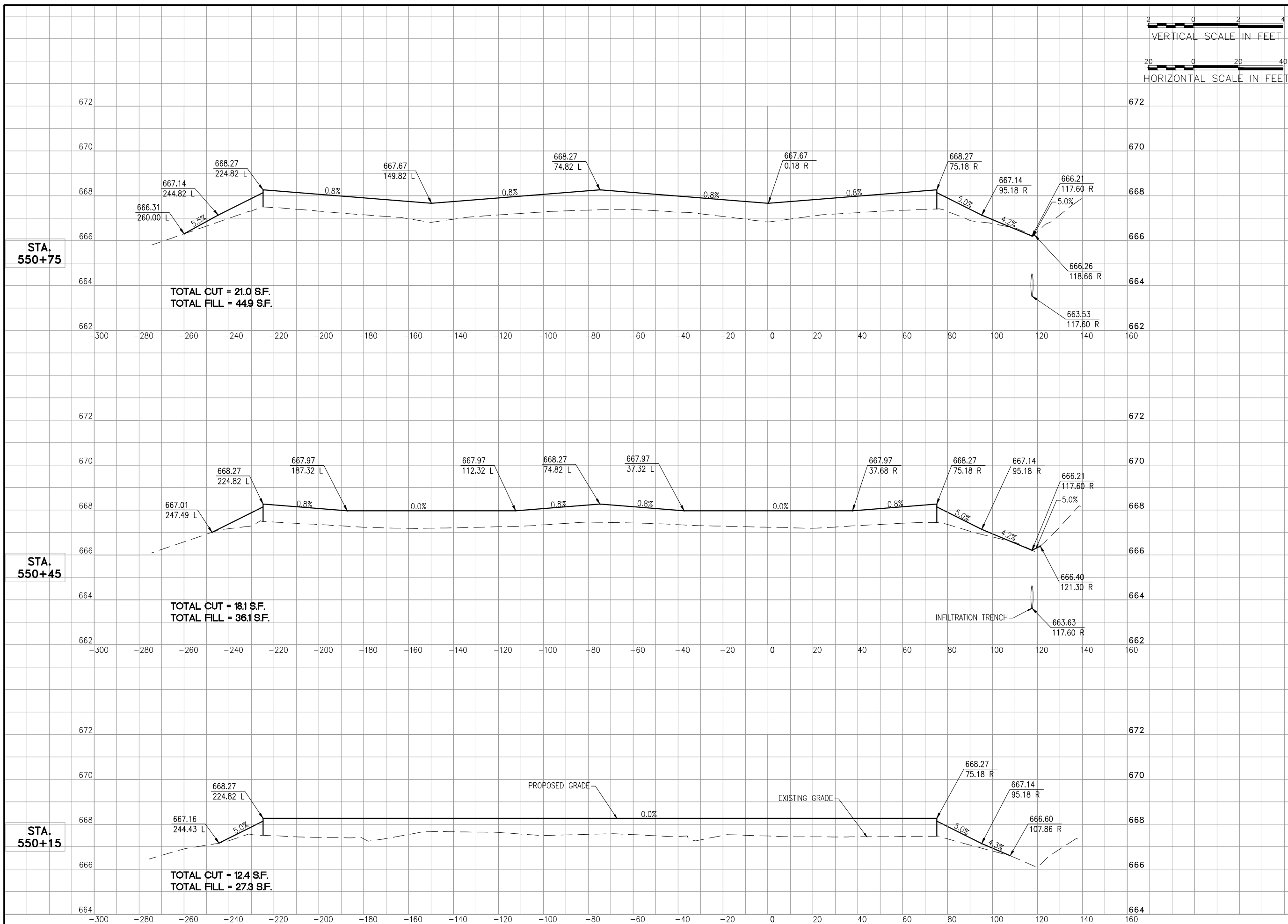
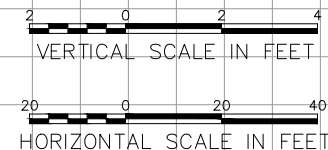

AIRCRAFT PARKING
APRON
REHABILITATION

IDA No: LOT-4298
SBG No: 3-17-SBGP-117
LE047

NO.	DATE	DESCRIPTION		
		LAY	DWN	REV

ISSUE: November 14, 2014
PROJECT NO: 13A0089
CAD FILE: 25-CROSS SECTIONS.DWG
LAYOUT BY: KMS 2/13/14
DRAWN BY: KMS 2/13/14
REVIEWED BY: RMH 11/14/14

© Copyright Hanson Professional Services Inc. 2011
SHEET TITLE

CROSS SECTIONS
APRON ALIGNMENT

OCT 23, 2014 8:40 AM HAUSM0682
I:\13\089\0084\013A0089\DESIGN\DRAWINGS\SHEETS\25-CROSS SECTIONS.DWG

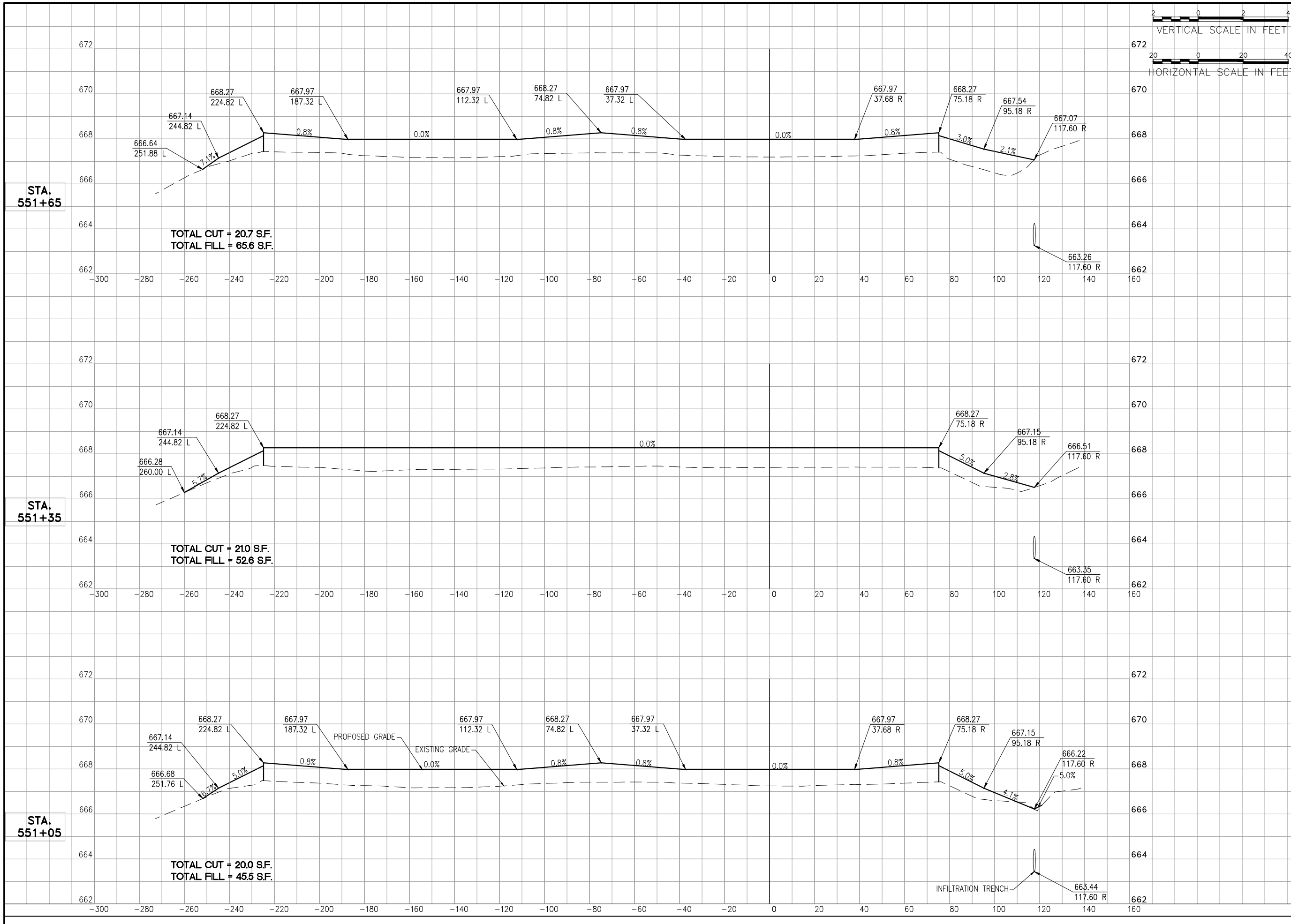
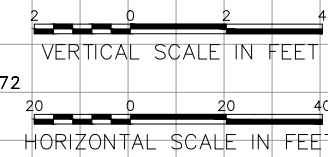

**AIRCRAFT PARKING
APRON
REHABILITATION**

IDA No: LOT-4298
SBG No: 3-17-SBGP-117
LE047

NO.	DATE	DESCRIPTION		
		LAY	DWN	REV

ISSUE: November 14, 2014
PROJECT NO: 13A0089
CAD FILE: 26-CROSS SECTIONS.DWG
LAYOUT BY: KMS 2/13/14
DRAWN BY: KMS 2/13/14
REVIEWED BY: RMH 11/14/14
© Copyright Hanson Professional Services Inc. 2011
SHEET TITLE

**CROSS SECTIONS
APRON ALIGNMENT**

OCT 23, 2014, 8:40 AM HAUSM0682
I:\3\085\008401\3A\0089\DESIGN\DRAWINGS\SHEETS\26-CROSS SECTIONS.DWG

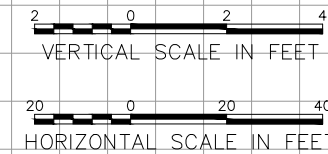

STA. 552+55

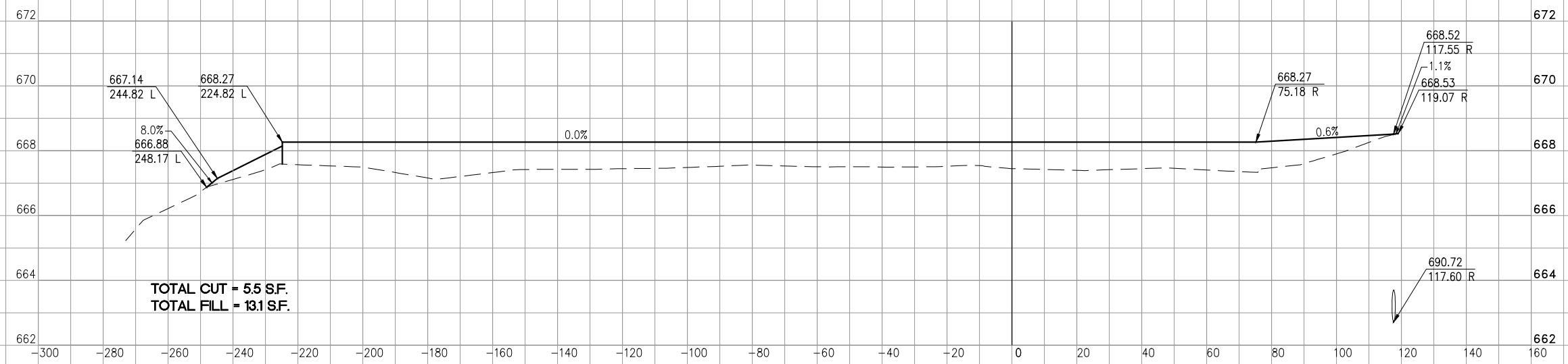

STA. 552+25

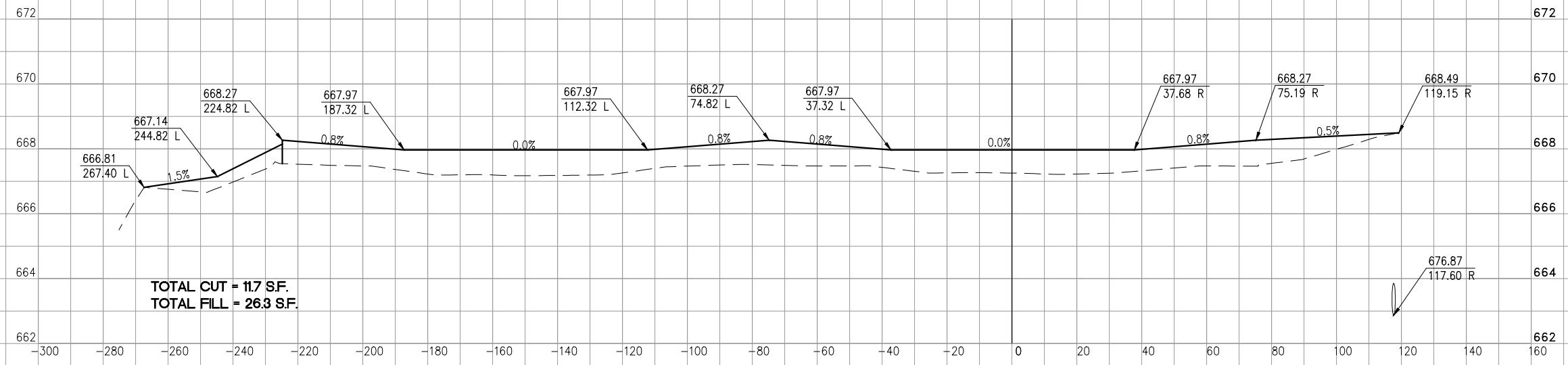

STA. 551+95

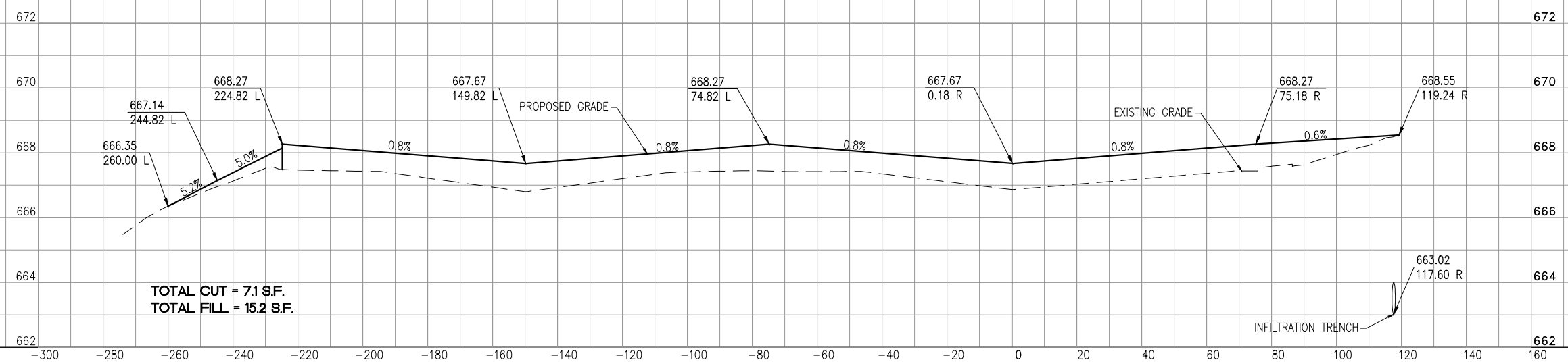

AIRCRAFT PARKING APRON REHABILITATION

IDA No: LOT-4298
SBG No: 3-17-SBGP-117
LE047

NO.	DATE	DESCRIPTION		
		LAY	DWN	REV

ISSUE: November 14, 2014
PROJECT NO: 13A0089
CAD FILE: 27-CROSS SECTIONS.DWG
LAYOUT BY: KMS 2/13/14
DRAWN BY: KMS 2/13/14
REVIEWED BY: RMH 11/14/14
© Copyright Hanson Professional Services Inc. 2011
SHEET TITLE

CROSS SECTIONS APRON ALIGNMENT

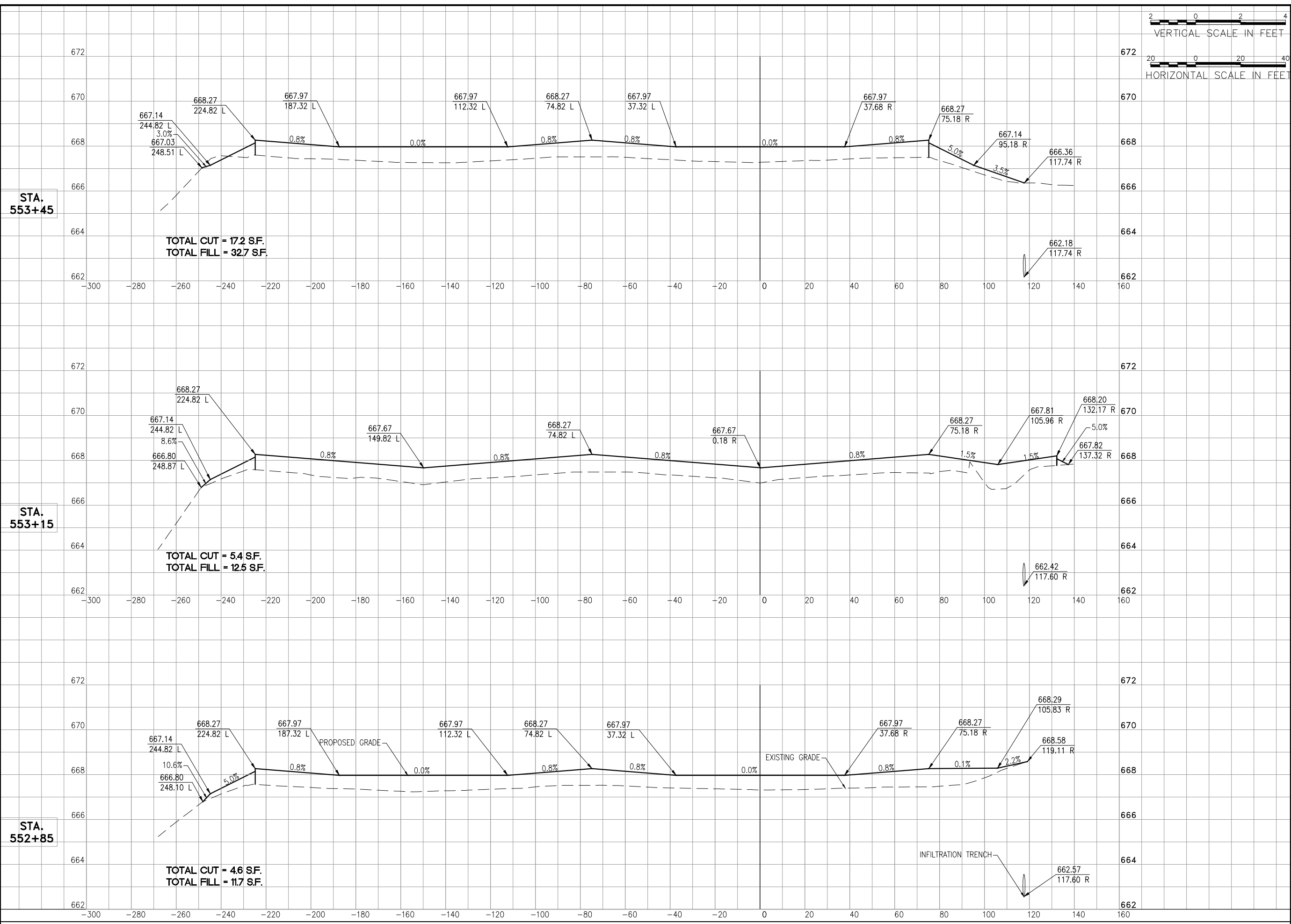
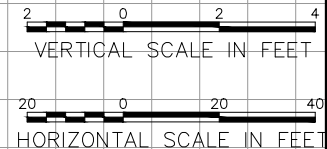

**AIRCRAFT PARKING
APRON
REHABILITATION**

IDA No: LOT-4298
SBG No: 3-17-SBGP-117
LE047

NO.	DATE	DESCRIPTION		
		LAY	DWN	REV

ISSUE: November 14, 2014
PROJECT NO: 13A0089
CAD FILE: 28-CROSS SECTIONS.DWG
LAYOUT BY: KMS 2/13/14
DRAWN BY: KMS 2/13/14
REVIEWED BY: RMH 11/14/14
© Copyright Hanson Professional Services Inc. 2011
SHEET TITLE

**CROSS SECTIONS
APRON ALIGNMENT**

OCT 23, 2014 8:41 AM HAUSM0682
I:\3\085\008401\3A0089\DESIGN\DRAWINGS\SHEETS\28-CROSS SECTIONS.DWG

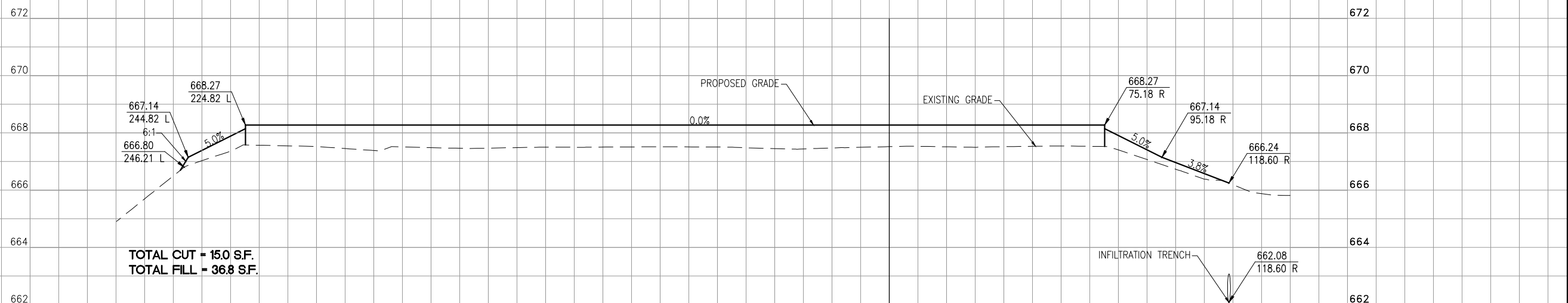
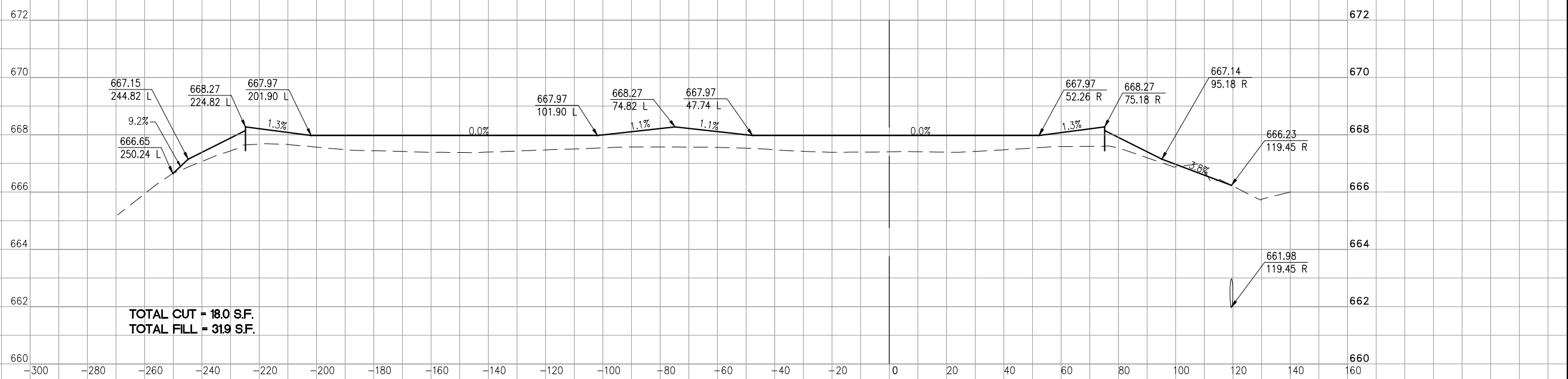
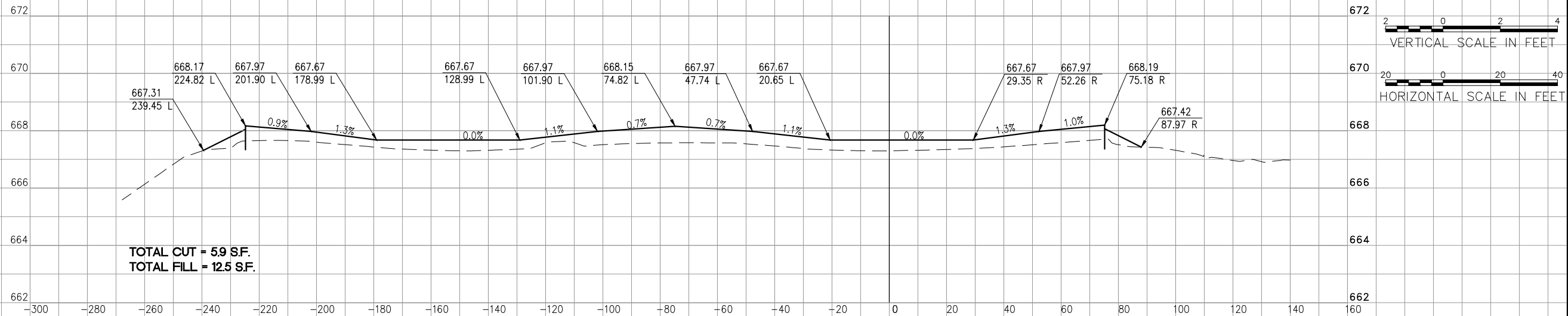

AIRCRAFT PARKING APRON REHABILITATION

IDA No: LOT-4298
SBG No: 3-17-SBGP-117
LE047

NO.	DATE	DESCRIPTION		
		LAY	DWN	REV

ISSUE: November 14, 2014
PROJECT NO: 13A0089
CAD FILE: 29-CROSS SECTIONS.DWG
LAYOUT BY: KMS 2/13/14
DRAWN BY: KMS 2/13/14
REVIEWED BY: RMH 11/14/14
© Copyright Hanson Professional Services Inc. 2011
SHEET TITLE

CROSS SECTIONS APRON ALIGNMENT

OCT 23, 2014 8:41 AM HAUSM0682 \\113085\008401\3A0089\DESIGN\DRAWINGS\SHEETS\29-CROSS SECTIONS.DWG

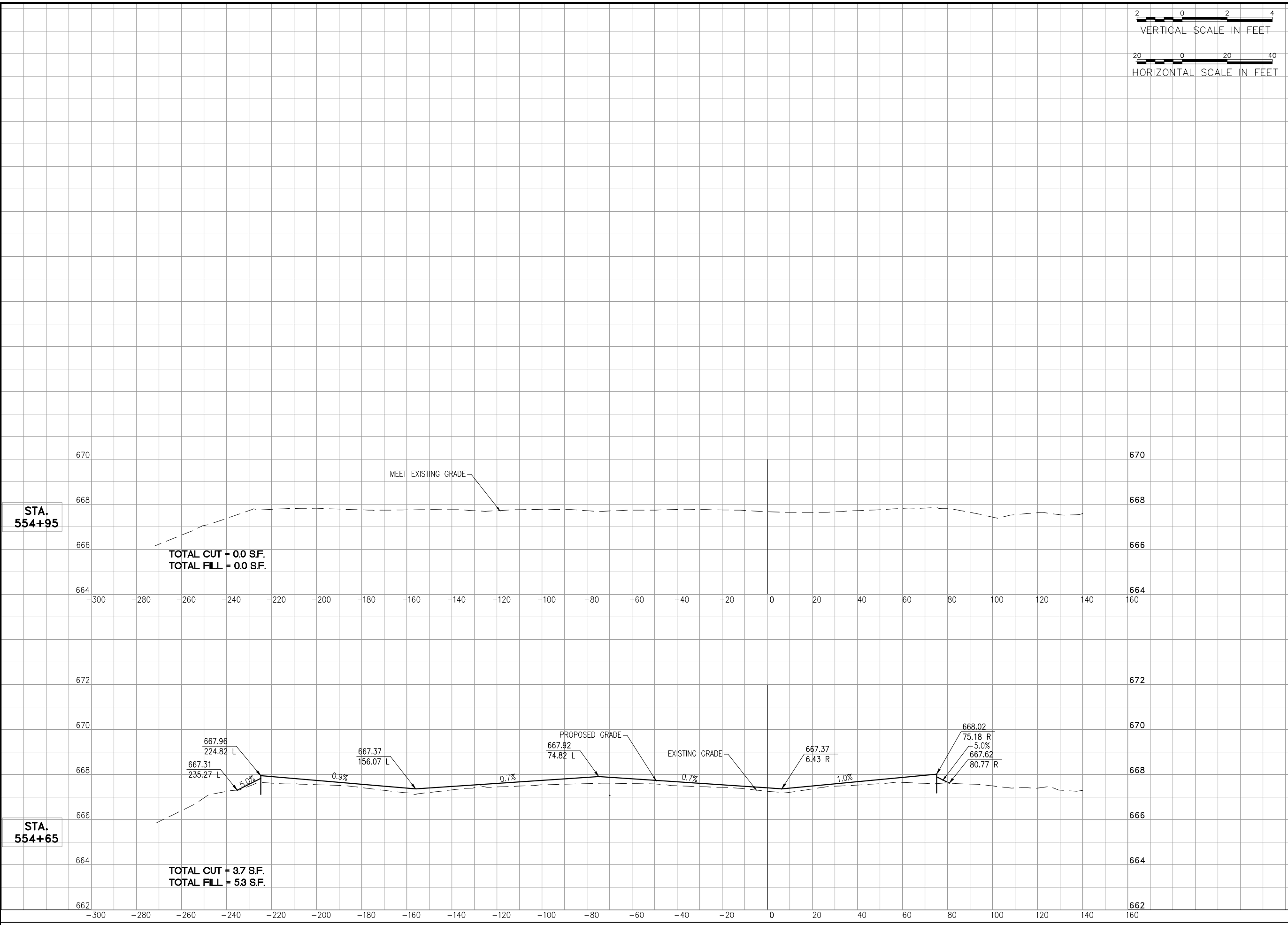
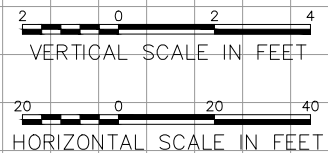

AIRCRAFT PARKING
APRON
REHABILITATION

IDA No: LOT-4298
SBG No: 3-17-SBGP-117
LE047

NO.	DATE	DESCRIPTION		
		LAY	DWN	REV

ISSUE: November 14, 2014
PROJECT NO: 13A0089
CAD FILE: 30-CROSS SECTIONS.DWG
LAYOUT BY: KMS 2/13/14
DRAWN BY: KMS 2/13/14
REVIEWED BY: RMH 11/14/14
SHEET TITLE

CROSS SECTIONS
APRON ALIGNMENT

AIRCRAFT PARKING
APRON
REHABILITATION

IDA No: LOT-4298
SBG No: 3-17-SBGP-117
LE047

NO.	DATE	DESCRIPTION		
		LAY	DWN	REV

ISSUE: November 14, 2014
PROJECT NO: 13A0089
CAD FILE: 31-XSECT-TXY J.DWG
LAYOUT BY: KMS 2/13/14
DRAWN BY: KMS 2/13/14
REVIEWED BY: RMH 11/14/14
© Copyright Hanson Professional Services Inc. 2011
SHEET TITLE

CROSS SECTIONS
TAXIWAY J ALIGNMENT

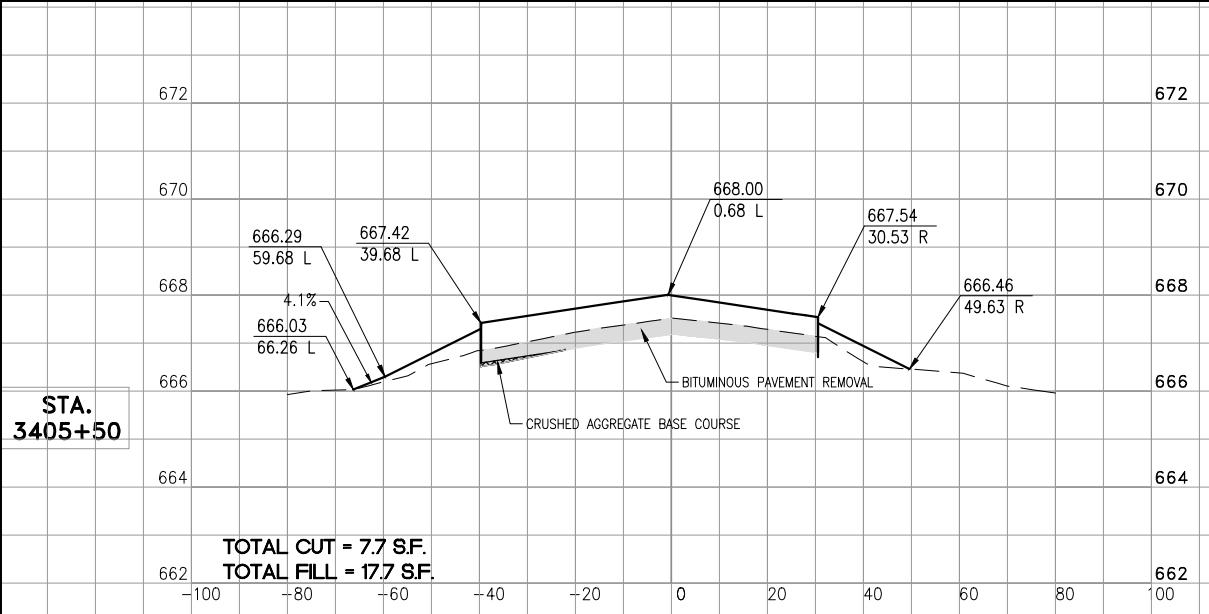
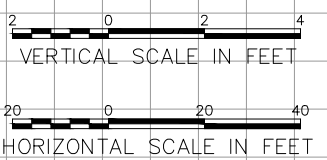

STA. 3406+25

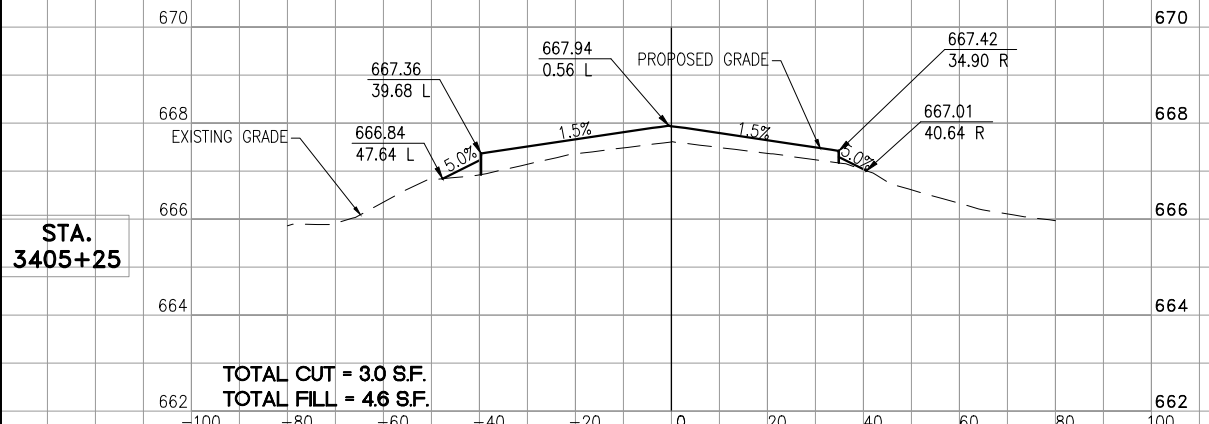
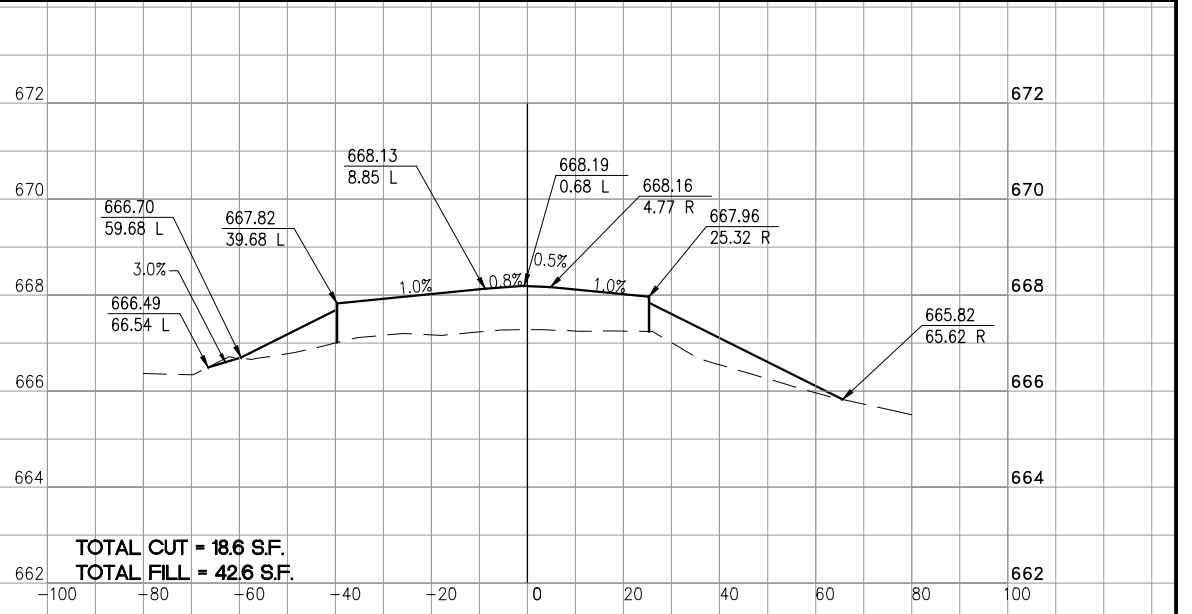

STA. 3406+00

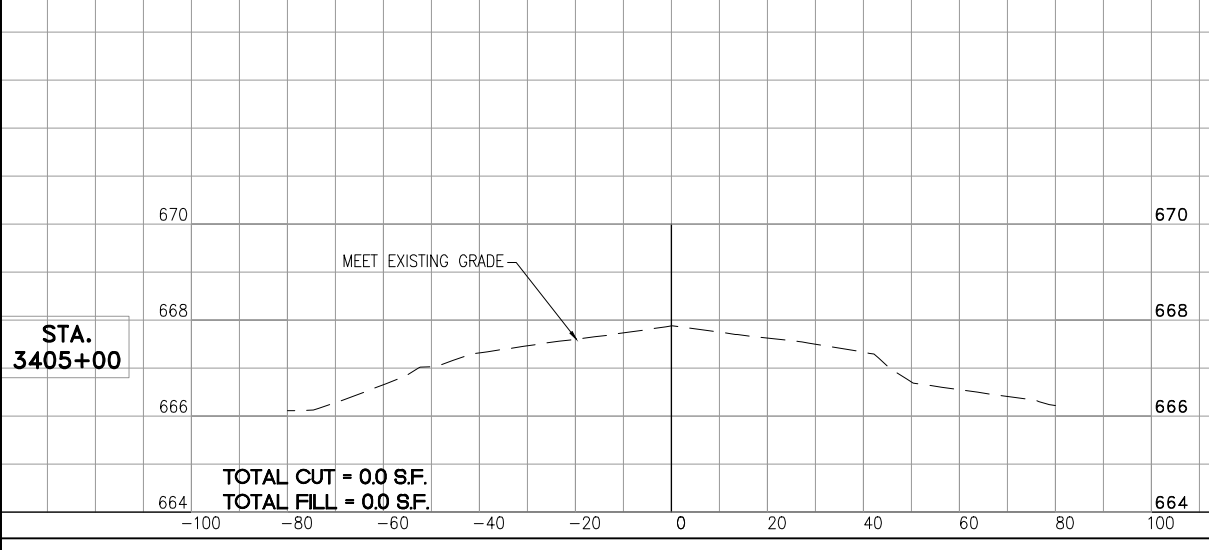
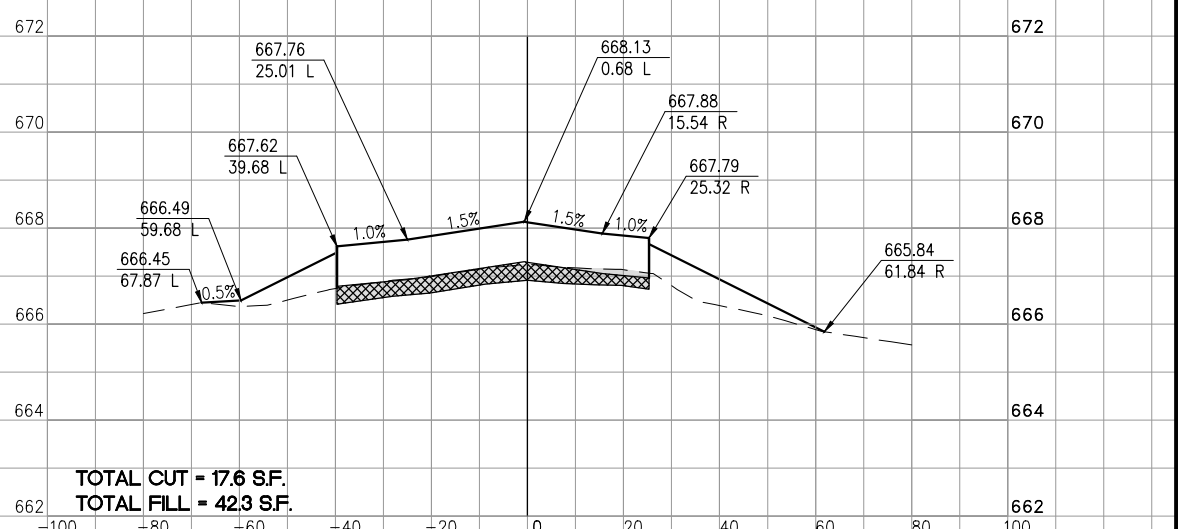

STA. 3405+75

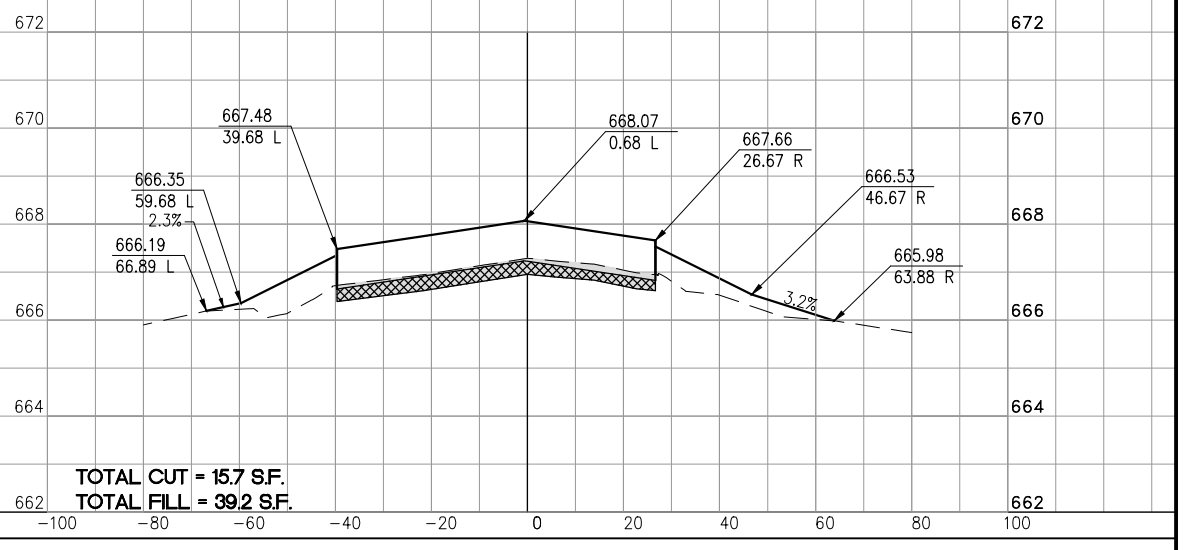

OCT 23, 2014 8:41 AM HAUSM06682 I:\31081008401\310810089\DESIGN\DRAWINGS\SHEETS\31-XSECT-TXY J.DWG

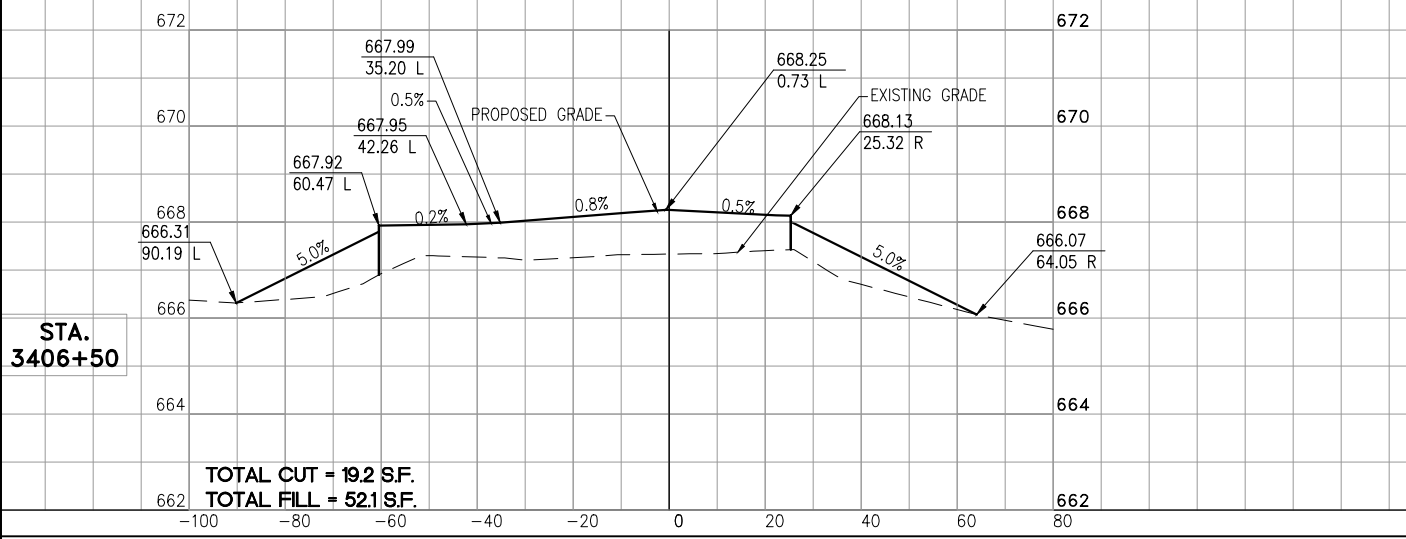
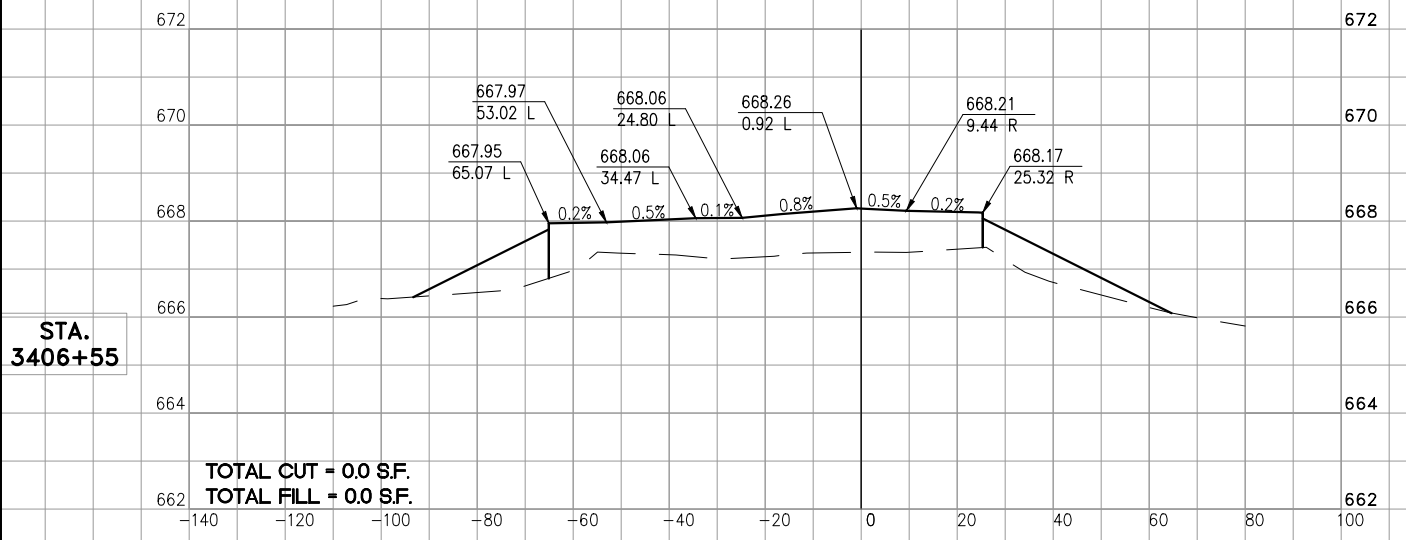
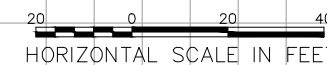
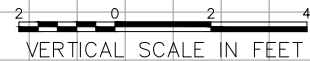

**AIRCRAFT PARKING
APRON
REHABILITATION**

IDA No: LOT-4298
SBG No: 3-17-SBGP-117
LE047

NO.	DATE	DESCRIPTION		
		LAY	DWN	REV

ISSUE: November 14, 2014
PROJECT NO: 13A0089
CAD FILE: 32-XSECT-TXY J.DWG
LAYOUT BY: KMS 2/13/14
DRAWN BY: KMS 2/13/14
REVIEWED BY: RMH 11/14/14
SHEET TITLE

**CROSS SECTIONS
TAXIWAY J ALIGNMENT**

OCT 23, 2014 8:42 AM HAUSM0682 I:\13\085\008401\3A0089\DESIGN\DRAWINGS\SHEETS\32-XSECT-TXY J.DWG

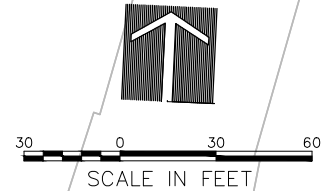

OCT 23, 2014, 8:42 AM HAUSM00682
I:\13\085\008401\3A0089\DESIGN\DRAWINGS\SHEETS\33-STAKING PLAN.DWG

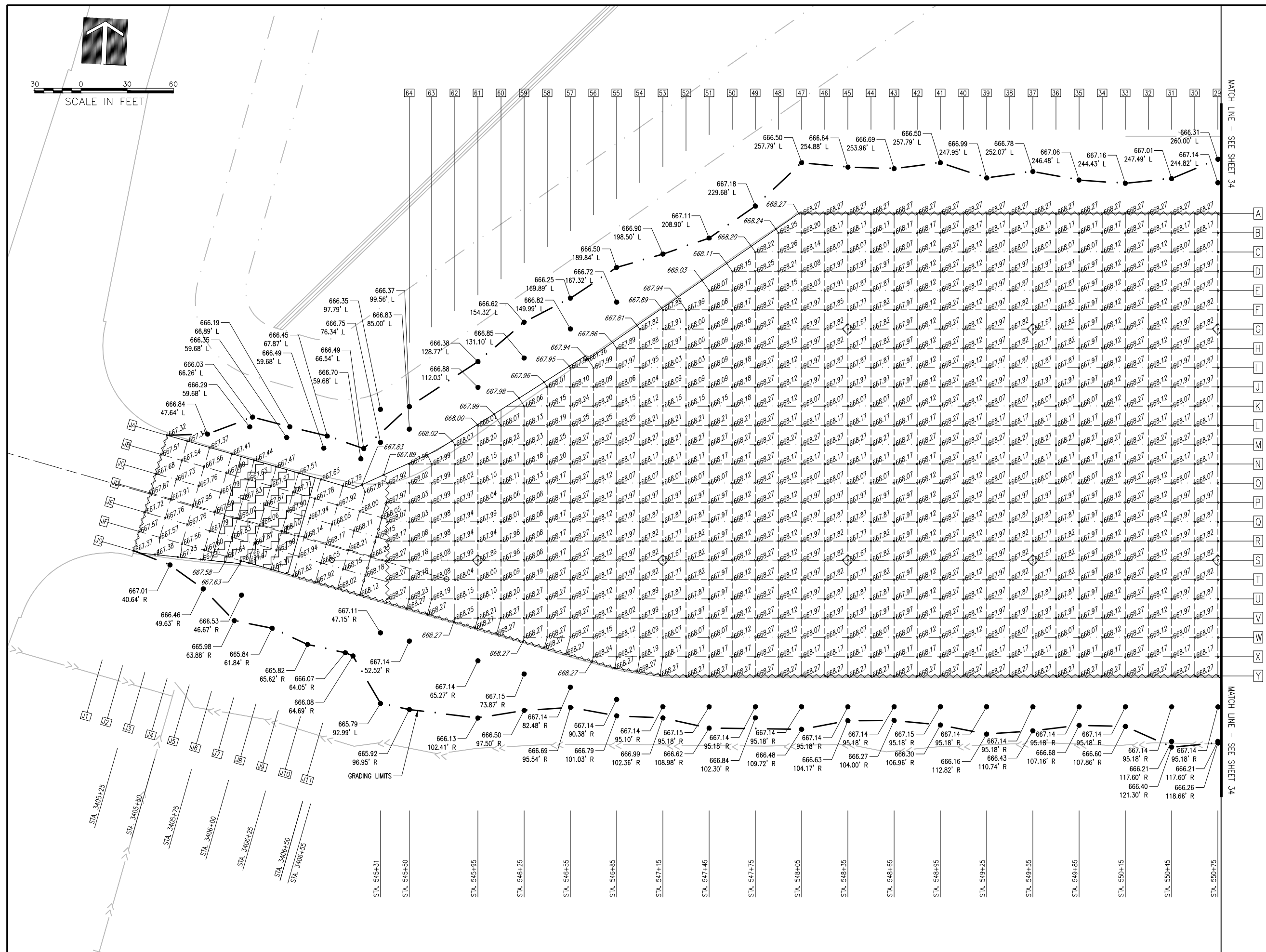

MATCH LINE - SEE SHEET 34
A
B
C
D
E
F
G
H
I
J
K
L
M
N
O
P
Q
R
S
T
U
V
W
X
Y
MATCH LINE - SEE SHEET 34

**AIRCRAFT PARKING
APRON
REHABILITATION**

IDA No: LOT-4298
SBG No: 3-17-SBGP-117
LE047

NO.	DATE	DESCRIPTION		
		LAY	DWN	REV

ISSUE: November 14, 2014
PROJECT NO: 13A0089
CAD FILE: 33-STAKING PLAN.DWG
LAYOUT BY: KMS 3/10/14
DRAWN BY: KMS 3/10/14
REVIEWED BY: RMH 11/14/14
© Copyright Hanson Professional Services Inc. 2011
SHEET TITLE

STAKING PLAN

**AIRCRAFT PARKING
APRON
REHABILITATION**

IDA No: LOT-4298
SBG No: 3-17-SBGP-117
LE047

NO.	DATE	DESCRIPTION		
		LAY	DWN	REV

ISSUE: November 14, 2014

PROJECT NO: 13A0089

CAD FILE: 35-JOINTING PLAN.DWG

LAYOUT BY: KMS 3/10/14

DRAWN BY: KMS 3/10/14

REVIEWED BY: RMH 11/14/14

© Copyright Hanson Professional Services Inc. 2011

SHEET TITLE

JOINTING PLAN

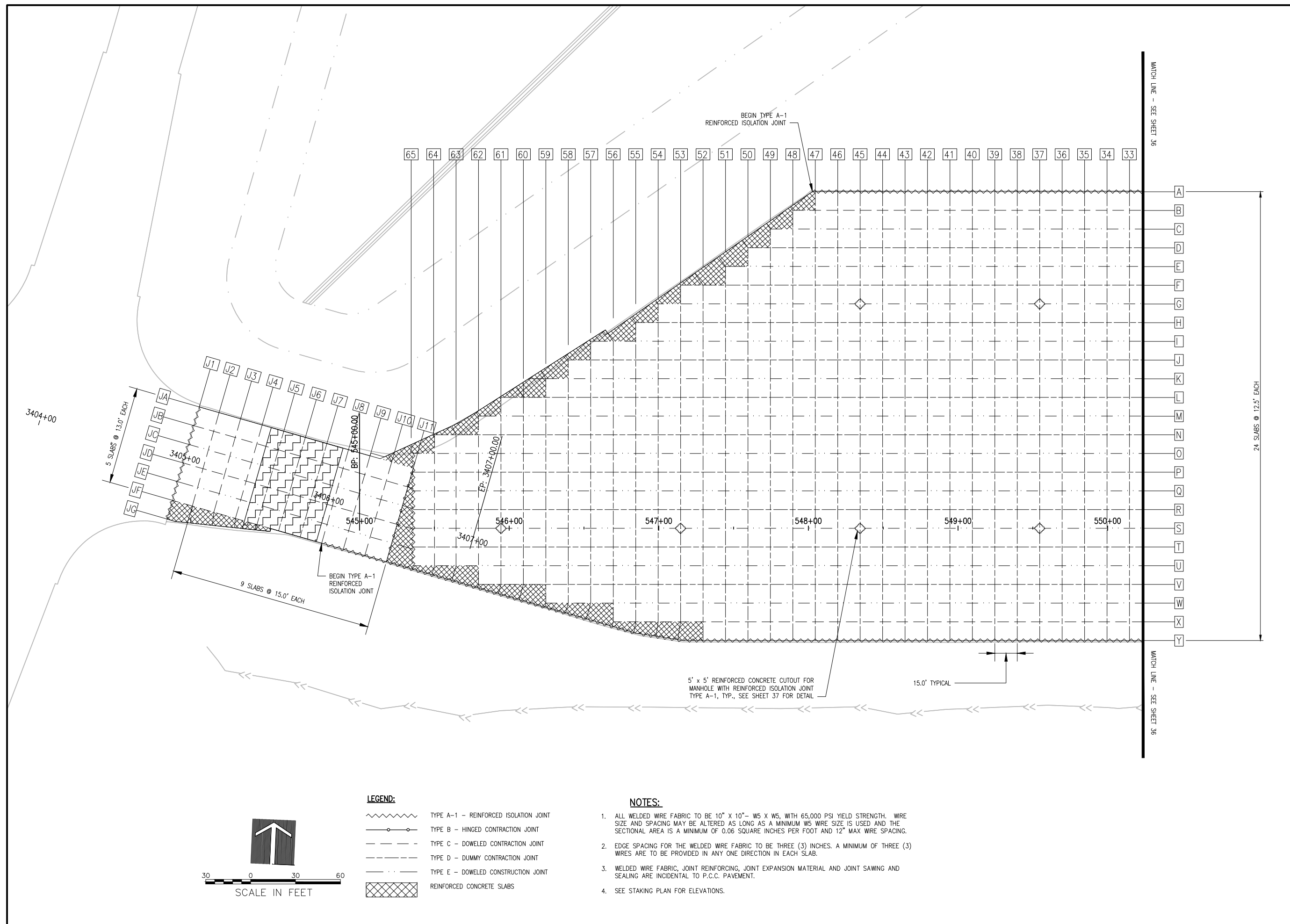

- LEGEND:**
- TYPE A-1 - REINFORCED ISOLATION JOINT
 - TYPE B - HINGED CONTRACTION JOINT
 - TYPE C - DOWELED CONTRACTION JOINT
 - TYPE D - DUMMY CONTRACTION JOINT
 - TYPE E - DOWELED CONSTRUCTION JOINT
 - REINFORCED CONCRETE SLABS

- NOTES:**
1. ALL WELDED WIRE FABRIC TO BE 10" X 10"- W5 X W5, WITH 65,000 PSI YIELD STRENGTH. WIRE SIZE AND SPACING MAY BE ALTERED AS LONG AS A MINIMUM W5 WIRE SIZE IS USED AND THE SECTIONAL AREA IS A MINIMUM OF 0.06 SQUARE INCHES PER FOOT AND 12" MAX WIRE SPACING.
 2. EDGE SPACING FOR THE WELDED WIRE FABRIC TO BE THREE (3) INCHES. A MINIMUM OF THREE (3) WIRES ARE TO BE PROVIDED IN ANY ONE DIRECTION IN EACH SLAB.
 3. WELDED WIRE FABRIC, JOINT REINFORCING, JOINT EXPANSION MATERIAL AND JOINT SAWING AND SEALING ARE INCIDENTAL TO P.C.C. PAVEMENT.
 4. SEE STAKING PLAN FOR ELEVATIONS.

OCT 23, 2014 8:42 AM HAUSM06682
I:\13085\089\4013A0089\DESIGN\DRAWINGS\SHEETS\35-JOINTING PLAN.DWG

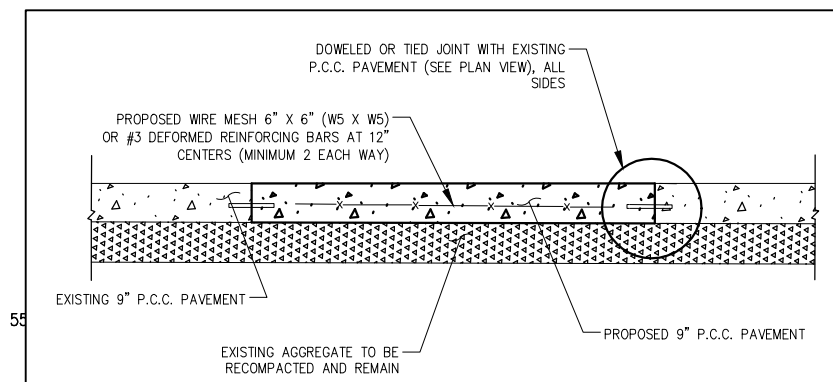
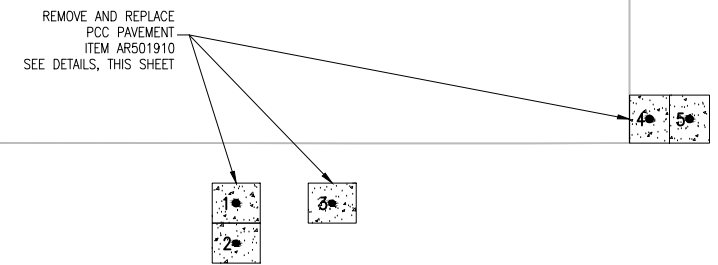
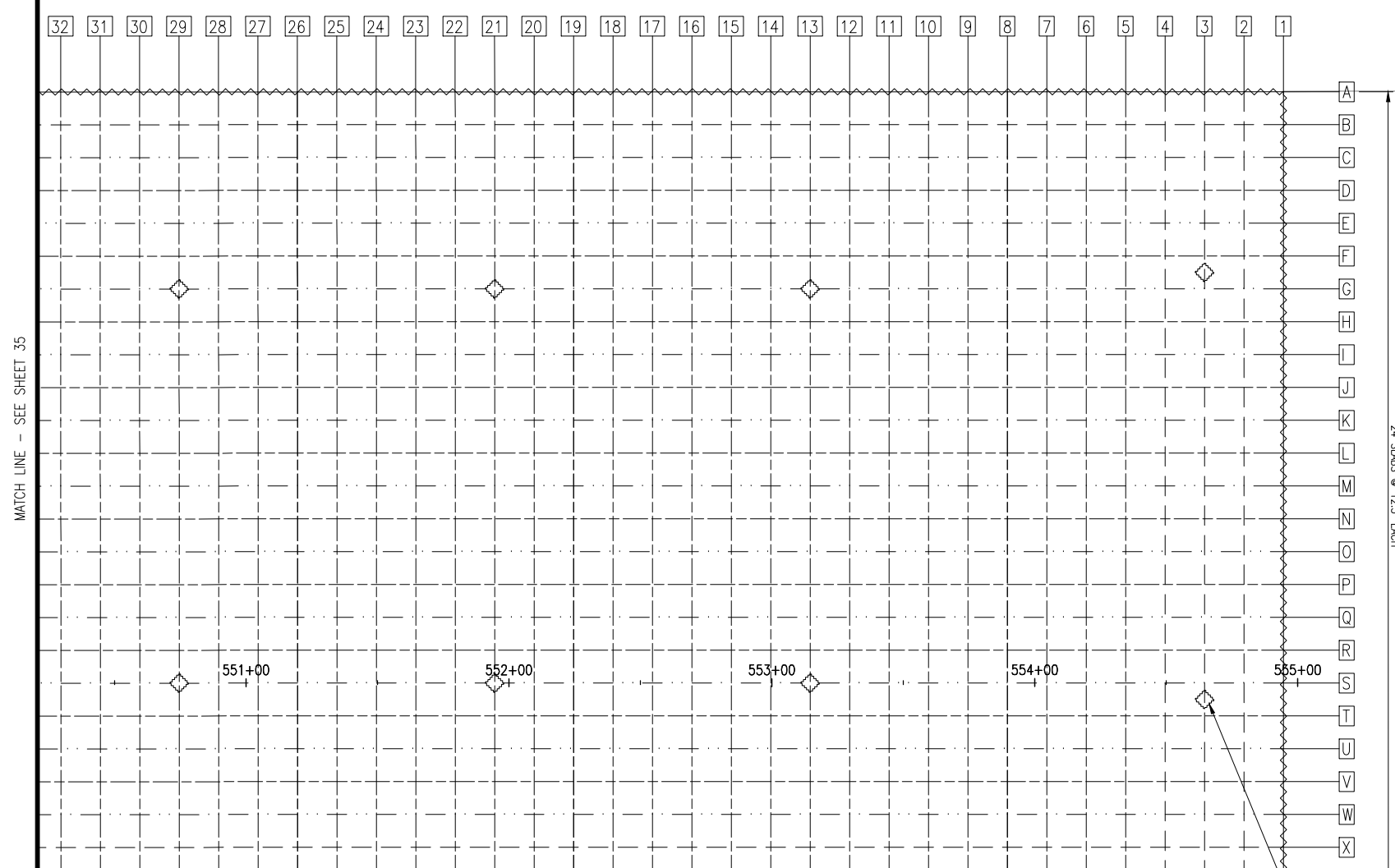

PROFILE VIEW

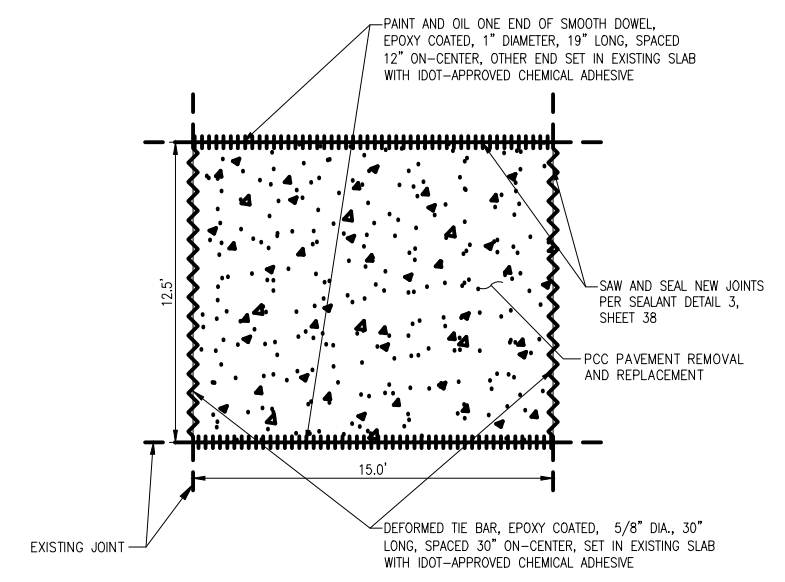

PLAN VIEW

NOTE: ALL WORK PAID UNDER ITEM AR501910
PCC PAVEMENT REMOVAL AND REPLACEMENT

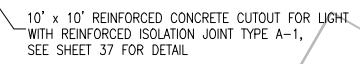
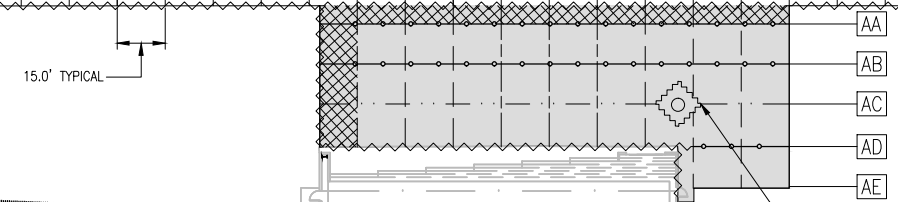

LEGEND:

- 8" PCC
- REMOVE AND REPLACE PCC PANEL

NOTES:

1. SEE SHEET 35 FOR NOTES AND LEGEND

AIRCRAFT PARKING APRON REHABILITATION

IDA No: LOT-4298
SBG No: 3-17-SBGP-117
LE047

NO.	DATE	DESCRIPTION		
		LAY	DWN	REV

ISSUE: November 14, 2014
PROJECT NO: 13A0089
CAD FILE: 36-JOINTING PLAN.DWG
LAYOUT BY: KMS 3/10/14
DRAWN BY: KMS 3/10/14
REVIEWED BY: RMH 11/14/14
© Copyright Hanson Professional Services Inc. 2011
SHEET TITLE

JOINTING PLAN

**AIRCRAFT PARKING
APRON
REHABILITATION**

IDA No: LOT-4298
SBG No: 3-17-SBGP-117
LE047

NO.	DATE	DESCRIPTION		
		LAY	DWN	REV

ISSUE: November 14, 2014
PROJECT NO: 13A0089
CAD FILE: 37-JOINTING DETAILS.DWG
LAYOUT BY: KMS 3/10/14
DRAWN BY: KMS 3/10/14
REVIEWED BY: RMH 11/14/14
© Copyright Hanson Professional Services Inc. 2011
SHEET TITLE

JOINTING DETAILS

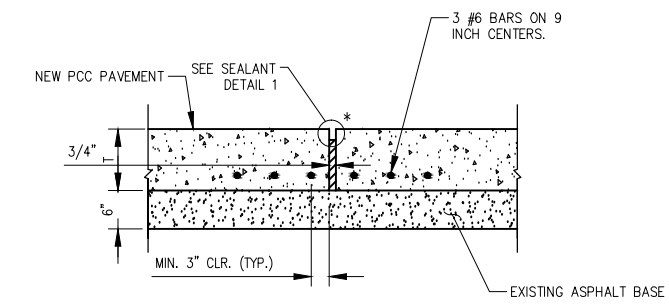

**TYPE A-1 - REINFORCED
ISOLATION JOINT**

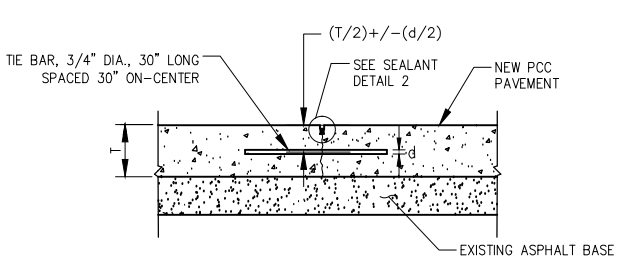

**TYPE B - HINGED
CONTRACTION JOINT**

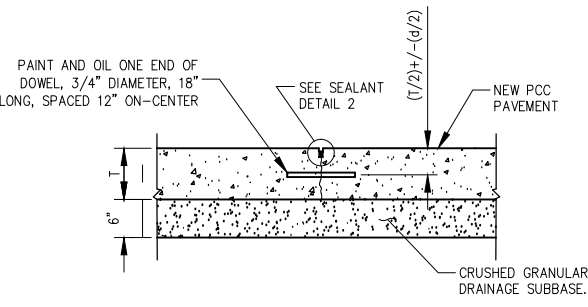

**TYPE C - DOWELED
CONTRACTION JOINT**

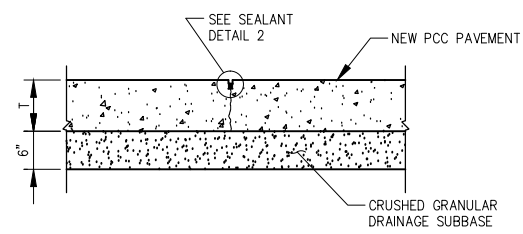

**TYPE D - DUMMY
CONTRACTION JOINT**

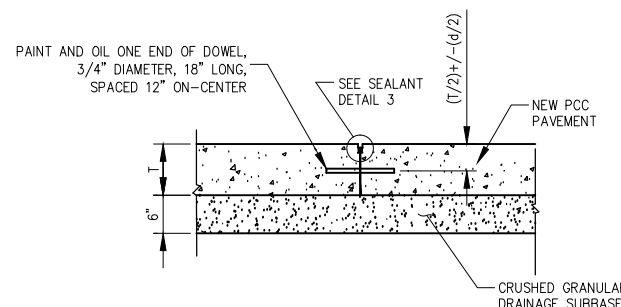

**TYPE E - DOWELED
CONSTRUCTION JOINT**

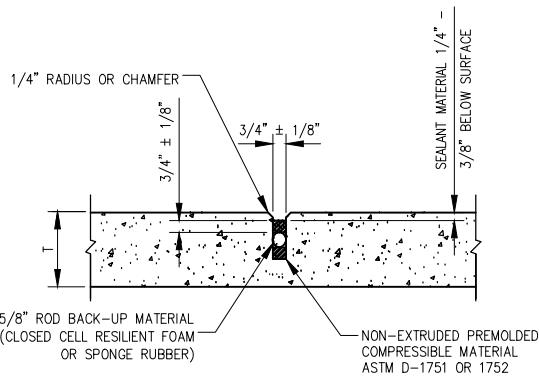

DETAIL 1 - SEALANT

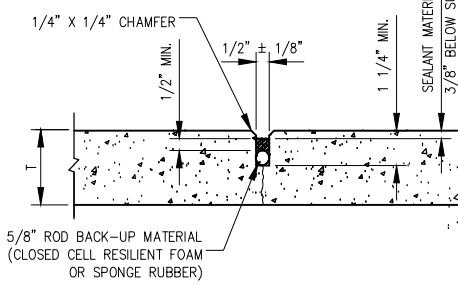

DETAIL 2 - SEALANT

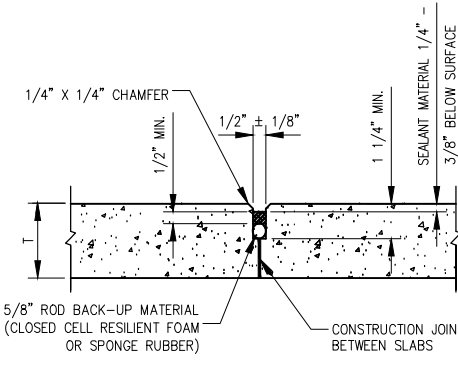

DETAIL 3 - SEALANT

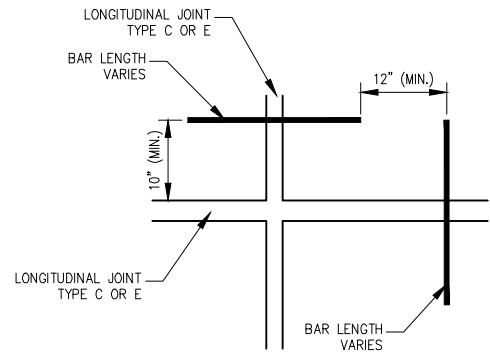

DOWEL PLAN VIEW

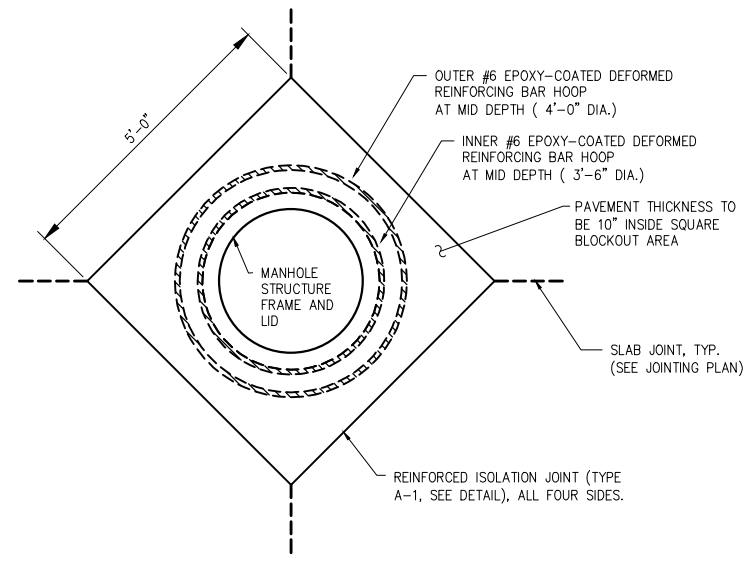

MANHOLE

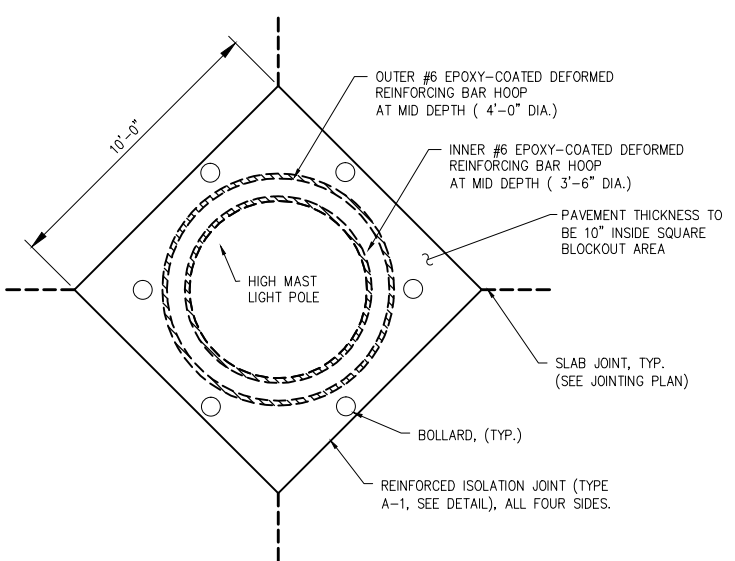

HIGH MAST LIGHT POLE

FRAMING NOTES
1. HOOP REINFORCEMENT REQUIRED AND SHALL BE ONE PIECE CONSTRUCTION HAVING A MINIMUM LAP LENGTH OF 2'-0".

JOINTING AND REINFORCING AT MANHOLES AND HIGH MAST LIGHT POLES

NOTE: FOR ITEM AR501508, "T" (THICKNESS) IS 8 INCHES
FOR ITEM 501510, "T" (THICKNESS) IS 10 INCHES.

OCT 23, 2014, 8:43 AM HAUSM0682
I:\3\085\008401\3A0089\DESIGN\DRAWINGS\SHEETS\37-JOINTING DETAILS.DWG

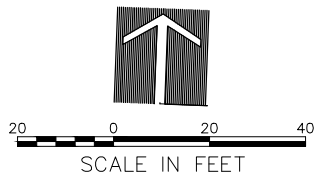

- NOTES:**
- GLASS SPHERES REQUIRED FOR ALL YELLOW AND WHITE MARKINGS.
GLASS SPHERES NOT REQUIRED FOR BLACK MARKING.
 - EPOXY MARKING SHALL BE USED ON PCC PAVEMENT.
 - ALL MARKING ON PCC PAVEMENT SHALL HAVE A 6" BLACK BORDER.
 - ALL BLACK MARKINGS ON PCC SHALL BE WATERBORNE.
 - REMOVAL OF MARKING FROM EXISTING PAVEMENT SHALL BE PERFORMED BY WATER BLASTING.

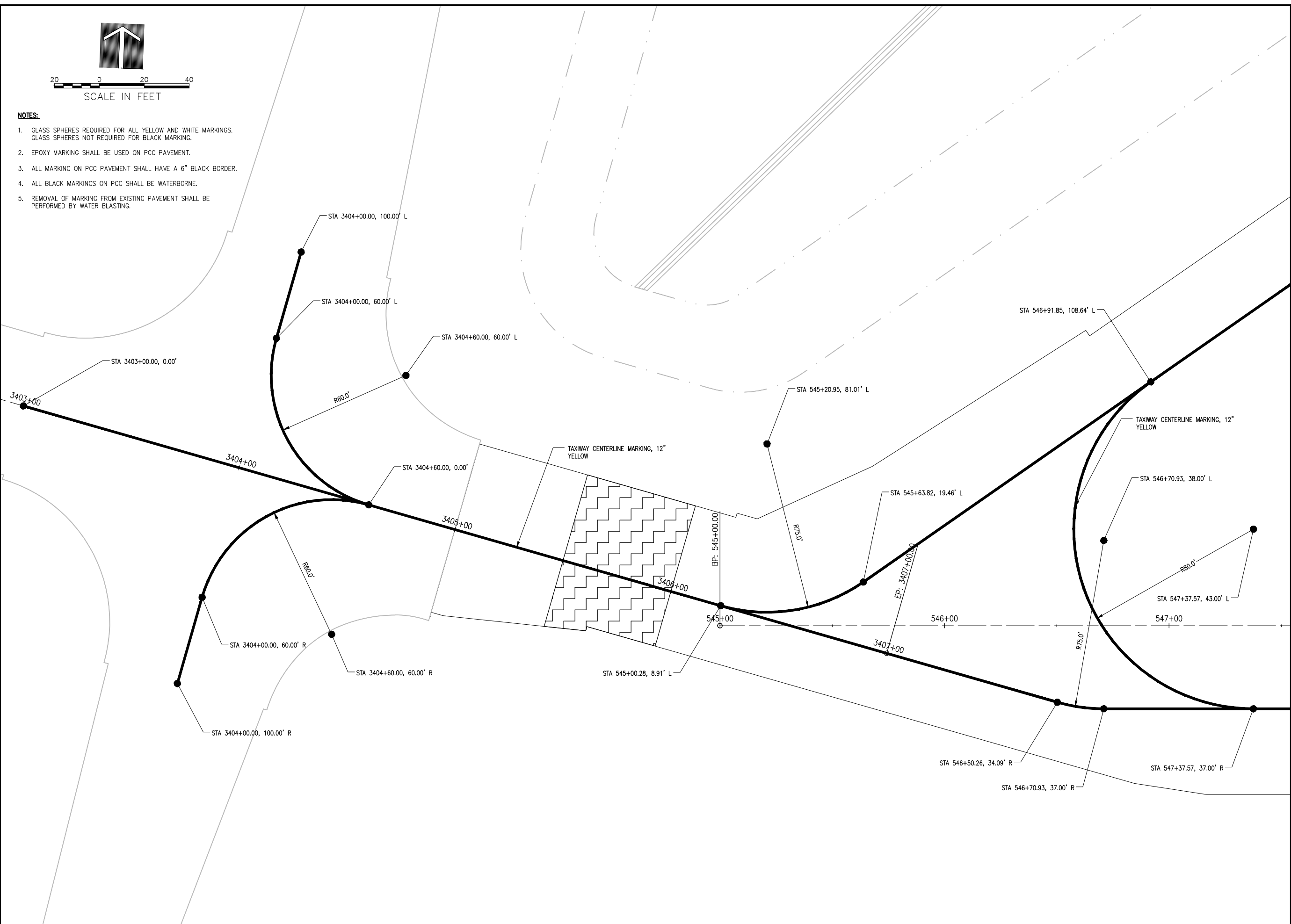

**AIRCRAFT PARKING
APRON
REHABILITATION**

IDA No: LOT-4298
SBG No: 3-17-SBGP-117
LE047

NO.	DATE	DESCRIPTION		
		LAY	DWN	REV

ISSUE: November 14, 2014
PROJECT NO: 13A0089
CAD FILE: 38-MARKING PLAN.DWG
LAYOUT BY: KMS 2/14/14
DRAWN BY: KMS 2/14/14
REVIEWED BY: RMH 11/14/14
© Copyright Hanson Professional Services Inc. 2011
SHEET TITLE

MARKING PLAN

OCT 23, 2014, 8:43 AM HAUSM0682
I:\13\089\008401\3A0089\DESIGN\DRAWINGS\SHEETS\38-MARKING PLAN.DWG

NOTES:

1. SEE SHEET 38 FOR NOTES
2. SEE SHEET 41 FOR TIE DOWN DETAIL AND LOCATIONS.

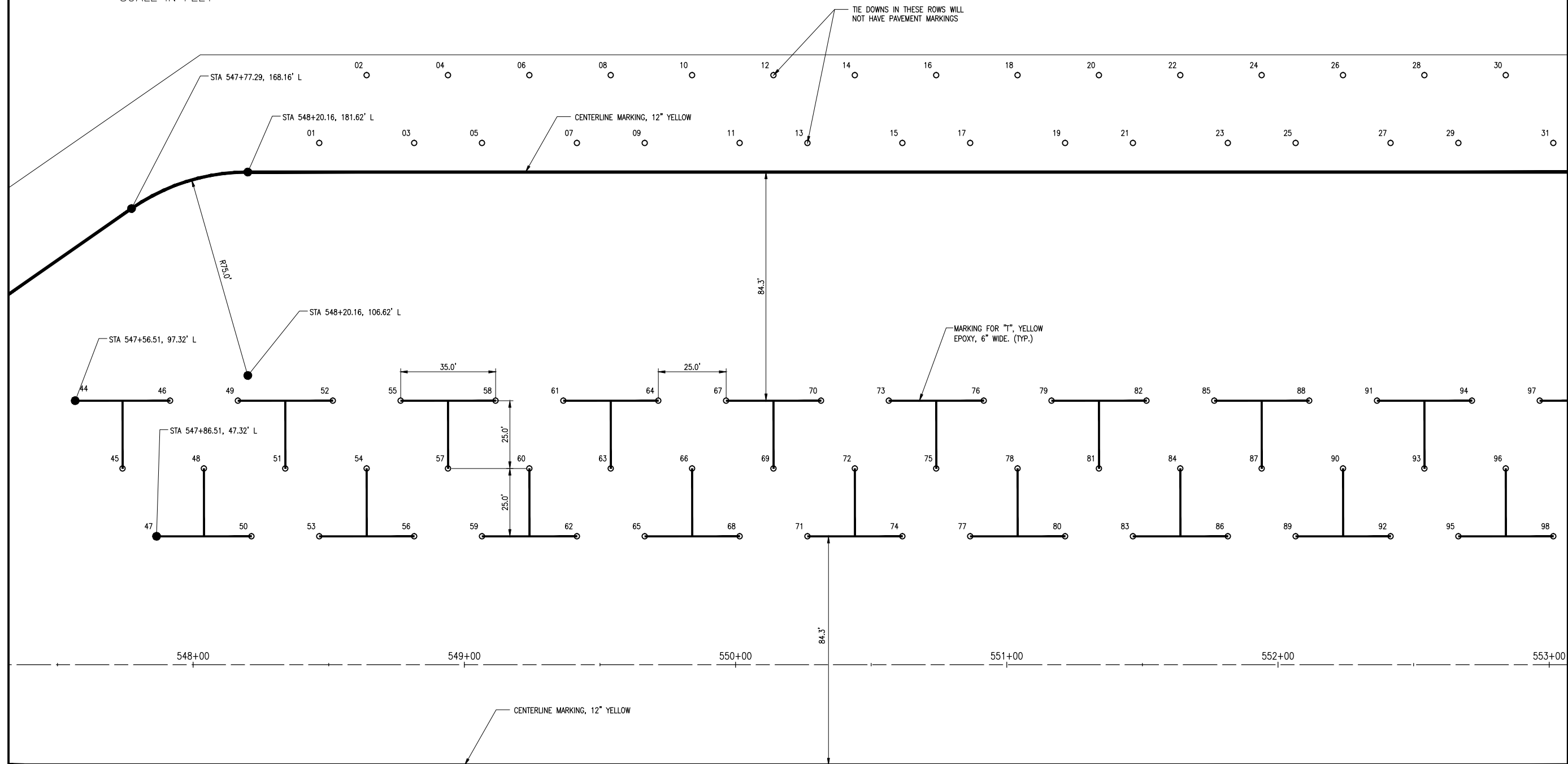
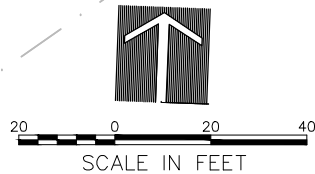

AIRCRAFT PARKING APRON REHABILITATION

IDA No: LOT-4298
SBG No: 3-17-SBGP-117
LE047

NO.	DATE	DESCRIPTION		
		LAY	DWN	REV

ISSUE: November 14, 2014
PROJECT NO: 13A0089
CAD FILE: 39-MARKING PLAN.DWG
LAYOUT BY: KMS 2/14/14
DRAWN BY: KMS 2/14/14
REVIEWED BY: RMH 11/14/14
© Copyright Hanson Professional Services Inc. 2011
SHEET TITLE

MARKING PLAN

OCT 23, 2014 8:43 AM HAUSM00682 I:\13\085\008401\3A\0089\DESIGN\DRAWINGS\SHEETS\39-MARKING PLAN.DWG

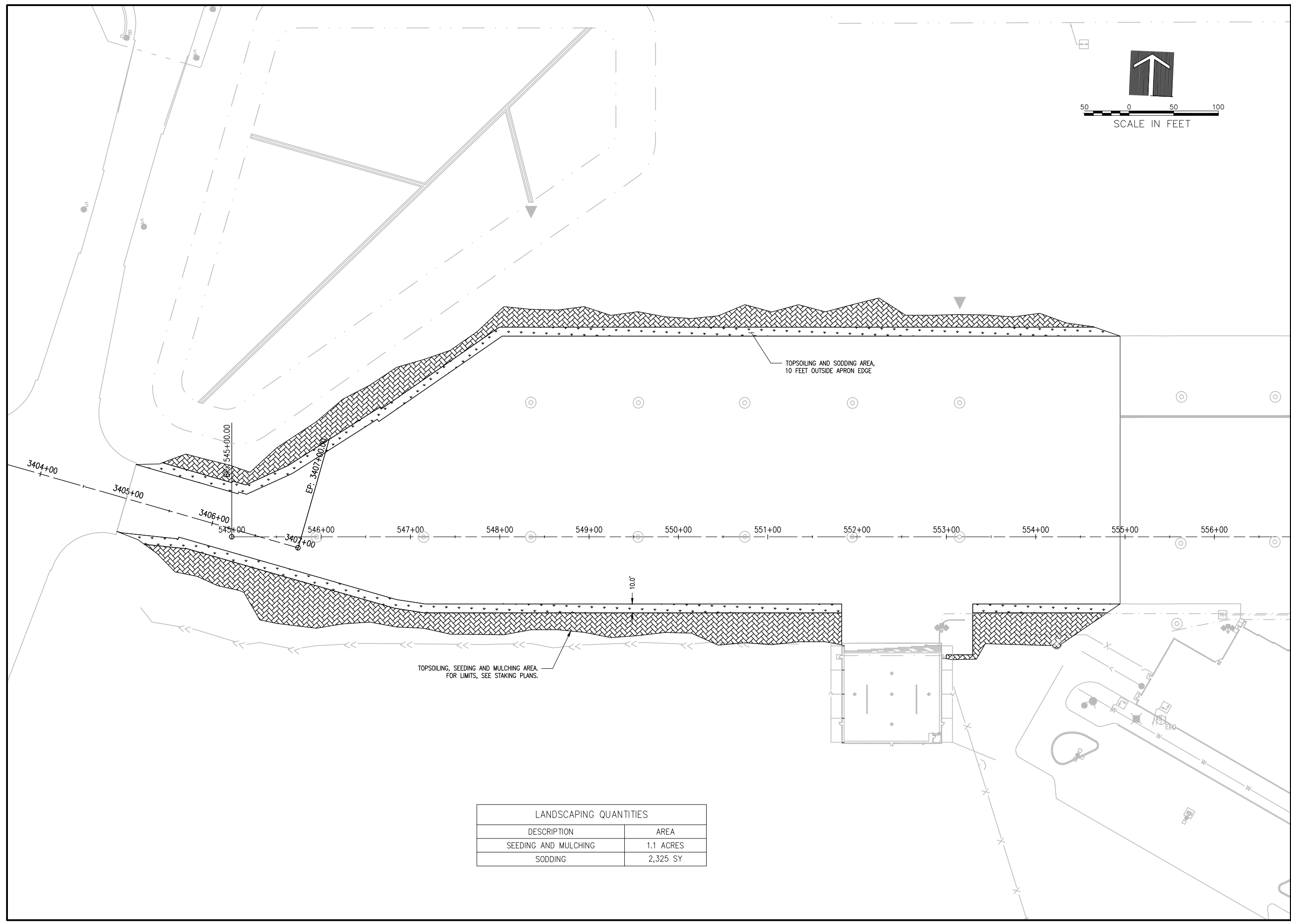
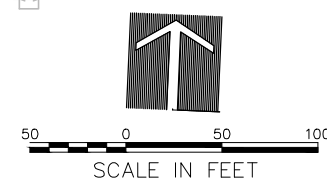

LANDSCAPING QUANTITIES	
DESCRIPTION	AREA
SEEDING AND MULCHING	1.1 ACRES
SODDING	2,325 SY

**AIRCRAFT PARKING
APRON
REHABILITATION**

IDA No: LOT-4298
SBG No: 3-17-SBGP-117
LE047

NO.	DATE	DESCRIPTION		
		LAY	DWN	REV

ISSUE: November 14, 2014
PROJECT NO: 13A0089
CAD FILE: 42-LANDSCAPING.DWG
LAYOUT BY: KMS 3/10/14
DRAWN BY: KMS 3/10/14
REVIEWED BY: RMH 11/14/14
© Copyright Hanson Professional Services Inc. 2011
SHEET TITLE

**LANDSCAPING
PLAN**

OCT 23, 2014 8:44 AM HAUSM00682
I:\13\08\008401\3A0089\DESIGN\DRAWINGS\SHEETS\42-LANDSCAPING.DWG