

SIGN NUMBER
 DECAL SIZE: 8" (200) W X 9" (230) H
 CHARACTER SIZE: 6" (150) W X 8" (200) H

7' (2 m) ABOVE PAVEMENT

HANDHOLE
 SEE DETAIL "A"

NOTES:

1. ALL DIMENSIONS ARE IN INCHES (MILLIMETERS) UNLESS OTHERWISE SHOWN
2. ALL CONDUIT ATTACHED TO STRUCTURE SHALL BE GALVANIZED RIGID METALIC CONDUIT, PVC COATED (GRMC, PVC)
3. THE USE OF LIQUID TIGHT METAL CONDUIT (TYPE LFMC) SHALL BE LIMITED TO LOCATIONS WHERE MOVEMENT IS ANTICIPATED AND SHALL NOT EXCEED 5' (1.5 m) IN LENGTH
4. ALL WORK INDICATED SHALL BE INCLUDED IN THE PAY ITEM FOR ELECTRIC CONNECTION TO SIGN STRUCTURE
5. THE SAFETY SWITCH SHALL BE LOCATED ON THE SIDE OF THE SIGN STRUCTURE WHICH IS CLOSEST TO THE SHOULDER, OR EDGE OF PAVEMENT.

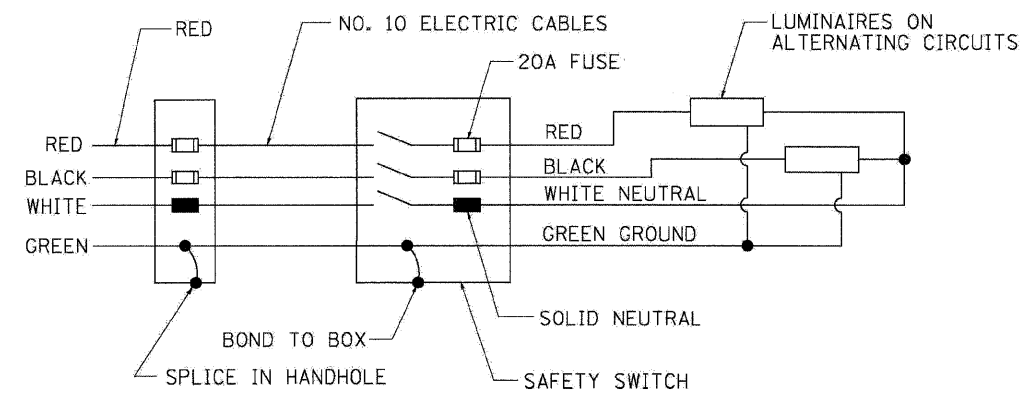

WIRING DIAGRAM

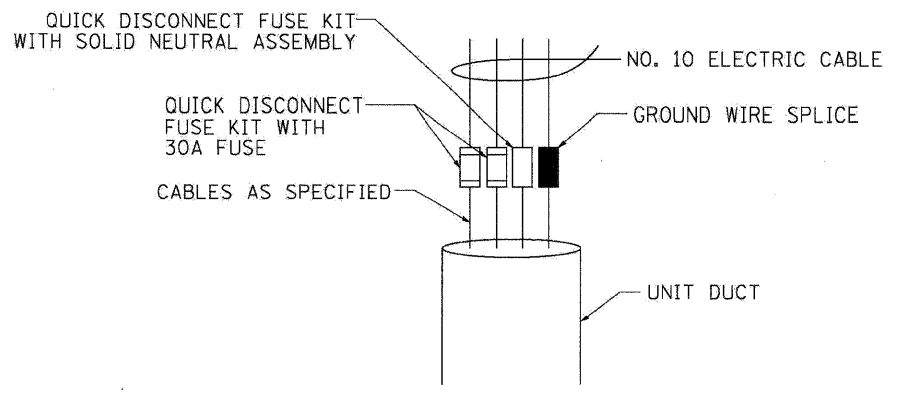

DETAIL A

FILE NAME =	DESIGNED - AJP	REVISED -
USER NAME = jma_ewaki	DRAWN - TMB	REVISED -
PLOT DATE = 1/25/2010	CHECKED - JMM	REVISED -
	DATE - 1/25/10	REVISED -

benesch

**STATE OF ILLINOIS
 DEPARTMENT OF TRANSPORTATION**

ELECTRIC CONNECTION TO SIGN STRUCTURE SPAN TYPE
 SCALE: N.T.S. SHEET NO. 5 OF 20 SHEETS STA. TO STA.

F.A.I. RTE.	SECTION	COUNTY	TOTAL SHEETS	SHEET NO.
290	(2727, ETC., 3131)RS-7	COOK	216	201
CONTRACT NO. 60G53				
FED. ROAD DIST. NO. ILLINOIS FED. AID PROJECT				

BE-600